

TRACER[®] EX

TRACER[®] IV
HEAVY DUTY/EXTRAWIDE

TRACER[®] TRANSPORT

INVACARE[®] MG

DEALER: THIS MANUAL MUST BE GIVEN TO THE USER
OF THE WHEELCHAIR.

USER: BEFORE USING THIS WHEELCHAIR, READ THIS
MANUAL AND SAVE FOR FUTURE REFERENCE.



Yes, you can.™

WARNING

DO NOT OPERATE THIS EQUIPMENT WITHOUT FIRST READING AND UNDERSTANDING THIS MANUAL. IF YOU ARE UNABLE TO UNDERSTAND THE WARNINGS, CAUTIONS, AND INSTRUCTIONS, CONTACT A HEALTHCARE PROFESSIONAL, DEALER OR TECHNICAL PERSONNEL IF APPLICABLE BEFORE ATTEMPTING TO USE THIS EQUIPMENT - OTHERWISE INJURY OR DAMAGE MAY RESULT.

SAVE THESE INSTRUCTIONS

TABLE OF CONTENTS

NOTE: The information in this owner's manual applies to the TRACER EX, TRACER IV, TRACER TRANSPORT and the INVACARE MG wheelchairs except where specified.

SPECIAL NOTES	4	PROCEDURE 4 - REAR WHEELS	20
SAFETY SUMMARY	5	REMOVING/INSTALLING THE REAR WHEELS	20
SAFETY/HANDLING OF WHEELCHAIRS	7	REPLACING REAR WHEEL HANDRIM	20
SPECIFICATIONS	12	REPLACING/REPAIRING REAR WHEEL TIRE/TUBE	20
SAFETY INSPECTION CHECKLIST	13	PROCEDURE 5 - FRONT CASTERS	21
TROUBLESHOOTING	14	INSTALLING/REPLACING SIX OR EIGHT-INCH FRONT CASTERS AND FORKS	21
MAINTENANCE	14	ADJUSTING FRONT CASTERS	21
PROCEDURE 1 - FRONT RIGGINGS	15	REPLACING/REPAIRING FRONT CASTER TIRE/TUBE	21
SWINGAWAY FOOTREST ASSEMBLY INSTALLATION	15	REPLACING FRONT CASTERS	21
SWINGAWAY FOOTREST HEIGHT ADJUSTMENT	15	PROCEDURE 6 - SEAT-TO-FLOOR HEIGHTS ..	22
HEEL LOOP REPLACEMENT	15	CHANGING SEAT-TO-FLOOR HEIGHT- TRACER EX ONLY	22
ELEVATING LEGREST ASSEMBLY INSTALLATION	16	PROCEDURE 7 - ANTI-TIPPERS/WHEEL LOCKS	
ADJUSTING THE ELEVATING LEGREST ASSEMBLY	16	INSTALLING ANTI-TIPPERS	23
PROCEDURE 2 - ARMS	17	WHEEL LOCK ADJUSTMENT	24
REMOVING OR REPLACING STANDARD ARMREST	17	PROCEDURE 8 - OPTIONS	25
ADJUSTING ARMREST HEIGHT - ADJUSTABLE HEIGHT ARMS ONLY	17	INSTALLING AMPUTEE ATTACHMENT	25
USING OR REPLACING FLIP-BACK ARMREST ..	17	INSTALLING FIXED HEIGHT I.V. ROD	25
PROCEDURE 3 - SEAT AND BACK	18	INSTALLING THE CARRYING POCKET	25
FOLD DOWN BACK - TRACER TRANSPORT ONLY	18	INSTALLING THE SEAT POSITIONING STRAP	26
REPLACING BACK UPHOLSTERY	18	INSTALLING/ADJUSTING THE FRONT ANTI-TIPPERS	26
REPLACING THE SEAT UPHOLSTERY	18	INSTALLING THE TELESCOPING I.V. ROD	28
ADJUSTING SEAT WIDTH	18	WARRANTY	31

SPECIAL NOTES

WARNING/CAUTION notices as used in this manual apply to hazards or unsafe practices which could result in personal injury or property damage.

NOTICE

THE INFORMATION CONTAINED IN THIS DOCUMENT IS SUBJECT TO CHANGE WITHOUT NOTICE.

WHEELCHAIR USER

As a manufacturer of wheelchairs, Invacare endeavors to supply a wide variety of wheelchairs to meet many needs of the end user. However, final selection of the type of wheelchair to be used by an individual rests solely with the user and his/her healthcare professional capable of making such a selection.

WHEELCHAIR TIE-DOWN RESTRAINTS AND SEAT POSITIONING STRAPS

Invacare recommends that wheelchair users NOT be transported in vehicles of any kind while in wheelchairs. As of this date, the Department of Transportation has not approved any tie-down systems for transportation of a user while in a wheelchair, in a moving vehicle of any type.

It is Invacare's position that users of wheelchairs should be transferred into appropriate seating in vehicles for transportation and use be made of the restraints made available by the auto industry. Invacare cannot and does not recommend any wheelchair transportation systems.

AS REGARDS RESTRAINTS - SEAT POSITIONING STRAPS - IT IS THE OBLIGATION OF THE DME DEALER, THERAPISTS AND OTHER HEALTHCARE PROFESSIONALS TO DETERMINE IF A SEATPOSITIONING STRAP IS REQUIRED TO ENSURE THE SAFE OPERATION OF THIS EQUIPMENT BY THE USER. SERIOUS INJURY CAN OCCUR IN THE EVENT OF A FALL FROM A WHEELCHAIR.

SAFETY SUMMARY

OPERATING INFORMATION

WARNING

To determine and establish your particular safety limits, practice bending, reaching and transferring activities in several combinations in the presence of a qualified health professional BEFORE attempting active use of the wheelchair.

DO NOT attempt to reach objects if you have to move forward in the seat.

DO NOT attempt to reach objects if you have to pick them up from the floor by reaching down between your knees.

DO NOT lean over the top of the back upholstery to reach objects from behind as this may cause the wheelchair to tip over.

DO NOT shift your weight or sitting position toward the direction you are reaching as the wheelchair may tip over.

DO NOT tilt the wheelchair without assistance.

DO NOT use an escalator to move a wheelchair between floors. Serious bodily injury may occur.

DO NOT attempt to stop a moving wheelchair with the wheel locks. WHEEL LOCKS ARE NOT BRAKES.

Before attempting to transfer in or out of the wheelchair, every precaution should be taken to reduce the gap distance. Turn both casters toward the object you are transferring onto. When transferring to and from the wheelchair, ALWAYS ENGAGE BOTH WHEEL LOCKS.

DO NOT operate on roads, streets or highways.

DO NOT climb, go up or down ramps or traverse slopes greater than 9°.

DO NOT attempt to move up or down an incline with a water, ice or oil film.

DO NOT attempt to ride over curbs or obstacles. Doing so may cause your wheelchair to tip over and cause bodily harm or damage to the wheelchair.

DO NOT use accessories, or adapters other than those authorized by Invacare.

DO NOT overtighten hardware attaching to the frame. This could cause damage to the frame tubing.

Keep hands and fingers clear of moving parts to avoid injury.

DO NOT attempt to lift the wheelchair by any removable (detachable) parts. Lifting by means of any removable (detachable) parts of a wheelchair may result in injury to the user or damage to the wheelchair.

DO NOT stand on the frame of the wheelchair.

Anti-tippers MUST BE attached at all times. Inasmuch as the anti-tippers are an option on this wheelchair (You may order with or without the anti-tippers), Invacare strongly recommends ordering the anti-tippers as an additional safeguard for the wheelchair user.

When changing the seat-to-floor height you must adjust the anti-tippers accordingly.

DO NOT use the footplate as a platform when getting in or out of the wheelchair.

ALWAYS wear your SEAT POSITIONING STRAP. Inasmuch as the SEAT POSITIONING STRAP is an option on this wheelchair (You may order with or without the SEAT POSITIONING STRAP), Invacare strongly recommends ordering the SEAT POSITIONING STRAP as an additional safeguard for the wheelchair user.

SAFETY SUMMARY

WARNING

**S
A
F
E
T
Y

S
U
M
M
A
R
Y**

TIRE PRESSURE

DO NOT use your wheelchair unless it has the proper tire pressure (p.s.i.). **DO NOT** overinflate the tires. Failure to follow these suggestions may cause the tire to explode and cause bodily harm.

Replacement of a pneumatic tire or tube **MUST** be performed by an authorized Invacare Dealer or Qualified Technician.

WEIGHT TRAINING

Invacare **DOES NOT** recommend the use of its wheelchairs as a weight training apparatus. Invacare wheelchairs have **NOT** been designed or tested as a seat for any kind of weight training. If occupant uses said wheelchair as a weight training apparatus, **INVACARE SHALL NOT BE LIABLE FOR BODILY INJURY AND THE WARRANTY WILL BE VOID.**

WEIGHT LIMITATION

The **TRACER EX, TRACER TRANSPORT** and **INVACARE MG** wheelchairs have a weight limitation of 250 lbs. The **TRACER IV EXTRA WIDE** wheelchair has a weight limitation of 350 lbs. The **TRACER IV HEAVY DUTY** has a weight limitation of 450 lbs. with the heavy duty option.

SAFETY/HANDLING OF WHEELCHAIRS

“Safety and Handling” of the wheelchair requires the close attention of the wheelchair user as well as the assistant. This manual points out the most common procedures and techniques involved in the safe operation and maintenance of the wheelchair. It is important to practice and master these safe techniques until you are comfortable in maneuvering around the frequently encountered architectural barriers.

Use this information only as a “basic” guide. The techniques that are discussed on the following pages have been used successfully by many.

Individual wheelchair users often develop skills to deal with daily living activities that may differ from those described in this manual. Invacare recognizes and encourages each individual to try what works best for him/her in overcoming architectural obstacles that they may encounter, however ALL WARNINGS and CAUTIONS given in this manual MUST be followed. Techniques in this manual are a starting point for the new wheelchair user and assistant with “safety” as the most important consideration for all.

STABILITY AND BALANCE

WARNING

ALWAYS wear your seat positioning strap. Inasmuch as the SEAT POSITIONING STRAP is an option on this wheelchair (You may order with or without the Seat Positioning Strap), Invacare strongly recommends ordering the Seat Positioning Strap as an additional safeguard for the wheelchair user.

To assure stability and proper operation of your wheelchair, you must at all times maintain proper balance. Your wheelchair has been designed to remain upright and stable during normal daily activities as long as you do not move beyond the center of gravity.

Virtually all activities which involve movement in the wheelchair have an effect on the center of gravity. Invacare recommends using seat/chest positioning straps for additional safety while involved in activities that shift your weight.

DO NOT lean forward out of the wheelchair any further than the length of the armrests. Make sure the casters are pointing in the forward position whenever you lean forward. This can be achieved by advancing the wheelchair and then reversing it in a straight line.

COPING WITH EVERYDAY OBSTACLES

Coping with the irritation of everyday obstacles can be alleviated somewhat by learning how to manage your wheelchair. Keep in mind your center of gravity to maintain stability and balance.

A NOTE TO WHEELCHAIR ASSISTANTS

When assistance to the wheelchair user is required, remember to use good body mechanics. Keep your back straight and bend your knees whenever tipping the wheelchair or traversing curbs, or other impediments.

WARNING

DO NOT attempt to lift the wheelchair by any removable (detachable) parts. Lifting by means of any removable (detachable) parts of a wheelchair may result in injury to the user or damage to the wheelchair.

Also, be aware of detachable parts such as armrests or legrests. These must NEVER be used for hand-held or lifting supports, as they may be inadvertently released, resulting in possible injury to the user and/or assistant(s).

When learning a new assistance technique, have an experienced assistant help you before attempting it alone.

PERCENTAGE OF WEIGHT DISTRIBUTION

WARNING

DO NOT attempt to reach objects if you have to move forward in the seat or pick them up from the floor by reaching down between your knees.

Many activities require the wheelchair owner to reach, bend and transfer in and out of the wheelchair. These movements will cause a change to the normal balance, the center of gravity, and the weight distribution of the wheelchair. To determine and establish your particular safety limits, practice bending, reaching and transferring activities in several combinations in the presence of a qualified healthcare professional BEFORE attempting active use of the wheelchair.

Proper positioning is essential for your safety. When reaching, leaning, or bending forward, it is important to use the front casters as a tool to maintain stability and balance.

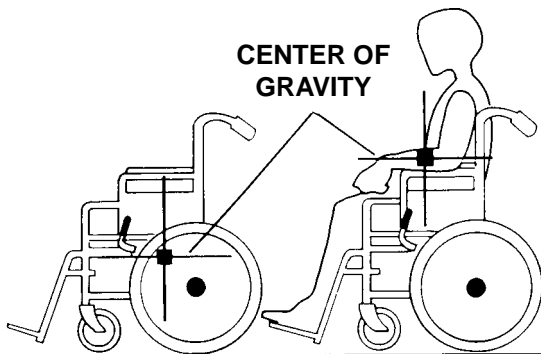

Example	46%	54%	103 lbs.	130 lbs.
---------	-----	-----	----------	----------

UNOCCUPIED

OCCUPIED

FUNCTIONAL REACH FROM A WHEELCHAIR

The approximate reach-limit values shown in the accompanying graph were derived on the basis of a sample of 91 male and 36 female wheelchair users. Note the difference between the maximum and the comfortable reach limits, a subjective but important consideration in design.

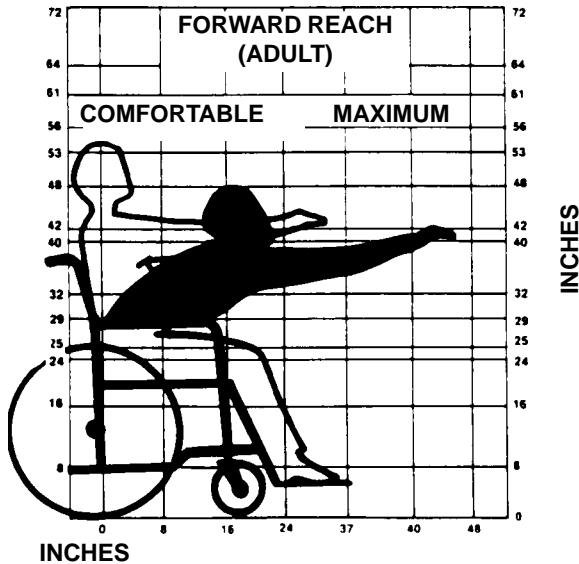

REACHING, LEANING AND BENDING - FORWARD

Position the front casters so that they are extended as far forward as possible and engage wheel locks. **DO NOT ATTEMPT TO REACH OBJECTS IF YOU HAVE TO MOVE FORWARD IN THE SEAT OR PICK THEM UP FROM THE FLOOR BY REACHING DOWN BETWEEN YOUR KNEES.**

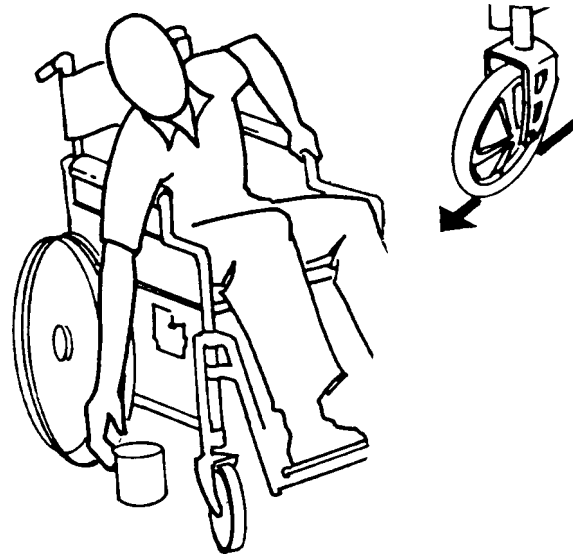

REACHING, LEANING - BACKWARDS

WARNING
DO NOT lean over the top of the back upholstery. This will change your center of gravity and may cause you to tip over.



Position wheelchair as close as possible to the desired object. Point front casters forward to create the longest possible wheelbase. Reach back only as far as your arm will extend without changing your sitting position.

TIPPING**WARNING**

DO NOT tip the wheelchair without assistance.

When tipping the wheelchair, an assistant should grasp the back of the wheelchair on a non-removable (non-detachable) part. Inform the wheelchair occupant before tipping the wheelchair and remind him/her to lean back. Be sure the occupant's feet and hands are clear of all wheels.

After mastering the techniques of tipping the wheelchair, use one (1) of the following methods to tackle curbs, short stairs, etc.

Tipping - Curbs: Method 1 - Wheelchair With Step Tubes

Apply a continuous downward motion until the balance point is achieved and the front casters clear the curb. At this point, the assistant will feel a difference in the weight distribution.

WARNING

When lowering the front casters of the wheelchair, **DO NOT** let the wheelchair drop the last few inches to the ground. This could result in injury to the occupant and/or damage to the wheelchair.

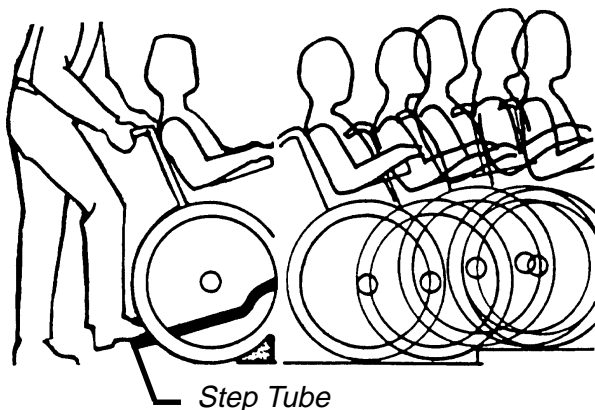

METHOD 1 - WHEELCHAIR WITH STEP TUBE

Roll the wheelchair forward and slowly lower the front of the wheelchair in one continuous movement onto the sidewalk. Do not let the wheelchair drop the last few inches to the ground. This could result in injury to the occupant. Push the wheelchair forward until the rear wheels roll up and over the curb.

Tipping - Curbs: Method 1 - Wheelchair Without Step Tubes

This method requires two (2) assistants. The second assistant should be positioned at the front of the wheelchair lifting upward on a non-removable (non-detachable) part of the wheelchair frame when lifting the wheelchair and stabilizing the wheelchair when the wheelchair is being lowered to the ground.

The first assistant should stand on the sidewalk and turn the wheelchair so that the rear wheels are against the curb. Turn the anti-tippers so the anti-tip wheels are pointing up. The wheelchair should be tilted back to the balance point and, in one continuous upward movement, the rear wheels should be pulled up and over the curb. **DO NOT** return the front casters to the ground until the wheelchair has been pulled backward far enough for the front casters to clear the edge of the curb.

WARNING

When lowering the front casters of the wheelchair, **DO NOT** let the wheelchair drop the last few inches to the ground. This could result in injury to the occupant and/or damage to the wheelchair.

Roll the wheelchair backward and **SLOWLY** lower the wheelchair in one continuous movement. **DO NOT** let the wheelchair drop the last few inches to the ground. This could result in injury to the occupant.

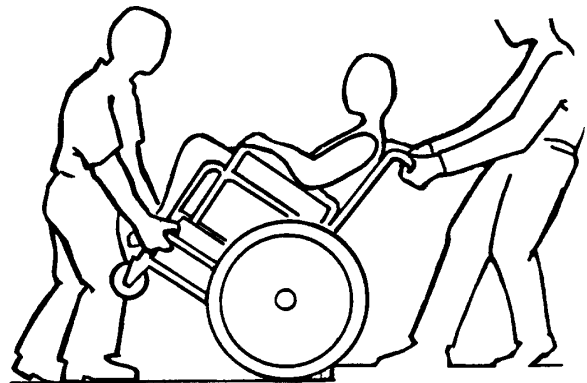

METHOD 2 - WHEELCHAIR WITHOUT STEP TUBE

STAIRWAYS

WARNING

ALWAYS wear your seat positioning strap. Inasmuch as the SEAT POSITIONING STRAP is an option on this wheelchair (You may order with or without the Seat Positioning Strap), Invacare strongly recommends ordering the Seat Positioning Strap as an additional safeguard for the wheelchair user.

Do not attempt to lift a wheelchair by lifting on any removable (detachable) parts. Lifting by means of any removable (detachable) parts of a wheelchair may result in injury to the user or damage to the wheelchair.

Extreme caution is advised when it is necessary to move an occupied wheelchair up or down the stairs. Invacare recommends using two (2) assistants and making thorough preparations. Make sure to use **ONLY** secure, non-detachable parts for hand-held supports.

Follow this procedure for moving the wheelchair between floors when an elevator is **NOT** available:

1. After the wheelchair has been tilted back to the balance point, one assistant (in the rear) backs the wheelchair up against the first step, while securely grasping a non-removable (non-detachable) part of the wheelchair for leverage.
2. The second assistant, with a firm hold on a non-detachable part of the framework, lifts the wheelchair up and over the stair and steadies the wheelchair as the first assistant places one (1) foot on the next stair and repeats STEP 1.
3. The wheelchair should not be lowered until the last stair has been negotiated and the wheelchair has been rolled away from the stairway.

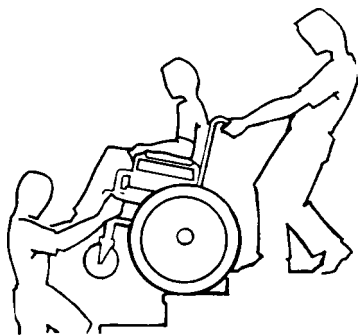
**ESCALATORS? SORRY!**

DO NOT use an escalator to move a wheelchair between floors. Serious bodily injury may occur.

TRANSFERRING TO AND FROM OTHER SEATS

WARNING

BEFORE attempting to transfer in or out of the wheelchair, every precaution should be taken to reduce the gap distance. Turn both casters toward the object you are transferring onto. Also be certain the wheel locks are engaged to help prevent the wheels from moving.

CAUTION

When transferring, position yourself as far back as possible in the seat. This will help prevent broken screws, damaged upholstery and the possibility of the wheelchair tipping forward.

NOTE: This activity may be performed independently provided you have adequate mobility and upper body strength.



Position the wheelchair as close as possible along side the seat to which you are transferring, with the front casters pointing toward it. Engage wheel locks. Shift body weight into seat with transfer.

During independent transfer, little or no seat platform will be beneath you. Use a transfer board if at all possible.

FOLDING AND UNFOLDING THE WHEELCHAIR

WARNING

Keep hands and fingers clear of moving parts to avoid injury.

Opening

1. Open the wheelchair by grasping the push handle of the wheelchair closest to you.
2. Tilt the wheelchair towards you (**raising the opposite wheel and caster off the ground/floor**).
3. Push downward on the **TOP** of the seat rail closest to you where the seat upholstery is attached until the wheelchair is fully open.
4. Engage both wheel locks, open the footrest/legrest for clearance and transfer into the wheelchair. Refer to TRANSFERRING TO AND FROM OTHER SEATS in this section of the manual.

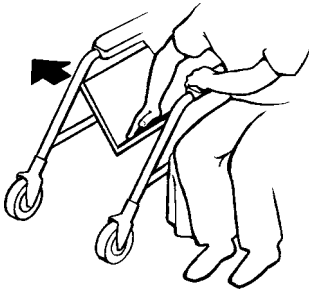

"HAMMOCK OR SLING SEAT" MODELS

Closing

1. Swing footrest/legrest in locked position to the front of the wheelchair.
2. Pivot footplates upward to vertical position.
3. With both hands, grasp the middle of the seat upholstery at the front and back edge and lift up.

NOTE: If wheelchair is equipped with carry straps, the wheelchair may be closed by pulling up on the straps.



"HAMMOCK OR SLING SEAT" MODELS

SPECIFICATIONS

S
P
E
C
I
F
I
C
A
T
I
O
N
S

	TRACER IV	TRACER TRANSPORT	INVACARE MG	TRACER EX
Seat Width:	20, 22 and 24-inches	14,16,18 and 20-inches	16-1/2 and 18-inches	16-1/2, 18 and 20-inches
Seat Depth:	18-inches	16-inches	16-inches	16-inches
Overall Width:				
Permanent Arm:	N/A	18-1/2 to 22-1/2-inches	23-1/4 and 24-3/4 inches	23-1/4 and 24-3/4-inches
Removable Arm:	27-1/2 to 31-1/2-inches	19 to 25 inches	24-1/2 and 26-inches	24-1/2, 26, and 28-inches
Overall Depth (w/o riggings):	32-inches	27-inches	32-1/2-inches	32-1/2-inches
Seat-to-Floor:	21-inches	21-inches	21-inches	21-inches
Back Style:	Fixed	Fixed and Fold Down	Fixed	Fixed
Back Height:	16-inches	16-inches	16-inches	16-inches
Arm Styles:	Fixed-Desk/Full Length Adjustable Height - Desk/Full Length	Permanent, Fixed-Desk/Full Length	Permanent or Removable Fixed Height Desk/Full Length	Permanent, Fixed-Desk/Full Length
Front Riggings:	Swingaway Footrest/Elevating Legrest, Articulating Elevating Legrest	Swingaway Footrest, Elevating Legrest	Hook On Elevating Legrest, Swingaway Footrest and Elevating Legrest	Swingaway Footrest, Elevating Legrest, Padded Elevating Legrest
Rear Axle:	Permanent	Permanent	Permanent	Permanent
Rear Wheels:	24-inch Composite; DTM, Pneumatic-Flat Free Insert -(24-inch Composite DTM Standard)	8x1-inch Solid Rubber (Standard) ,8x1-1/4-inch Composite Urethane	24-inch Composite - Urethane Tire	20, 22, 24-inch Composite; Urethane,Pneumatic, or Pneumatic Flat Free Insert- (24-inch Composite Urethane Standard)
Handrims:	Chrome	N/A	Composite	Composite (Standard) , Chrome, or Aluminum
Wheel Locks:	Push to Lock	Push to Lock	Push to Lock	Push to Lock
Caster Size:	8 x 1-inch Solid Rubber (Standard) , 8x 1-3/4-inch Semi-Pneumatic	8 x 1-inch Solid Rubber (Standard) 8x 1-1/4-inch Composite Urethane	8 x 1-inch Solid Rubber - Dark Grey	8 x1-inch Solid Rubber - Dark Grey (Standard) 8 x1-inch Solid Rubber - Light Grey, 8x1-1/4inch Pneumatic or Pneumatic Flat Free, 8x1-3/4-inch Semi Pneumatic, 8x2-inch Pnumatic, 6x1-inch Urethane - Light Grey, or Dark Grey
Upholstery:	Vinyl - dark blue (standard) , Marina Blue, Space Blue, Dove Grey, Ruby, and Camel	Vinyl - Lightweight Black (Standard) , Navy Blue, Blue Topaz or Claret Naughahyde and Navy Textilene	Silver Blue Vinyl	Midnight Blue (Standard) , Ruby
Weight (approx)*:				
Permanent Arm:	N/A	26 lbs.	35 lbs. (36-1/2 lbs. for Fixed Front End)	35 lbs.
Removable Arm:	52 lbs. (22" Wide)	31 lbs.	38 lbs.	38 lbs.
Shipping Weight (approx.)*:				
Permanent Arm:	N/A	30 lbs.	44-1/2 lbs. (46 lbs. for Fixed Front End)	44 1/2 lbs.
Removable Arm:	62 lbs.	35 lbs.	47-1/2 lbs.	47 1/2 lbs.

**Weights based on 18-inch wide chair without front rigging. All weights are approximate and will vary depending on how wheelchair is equipped.*

SAFETY INSPECTION CHECKLIST

NOTE: Every six (6) months take your wheelchair to a qualified dealer for a thorough inspection and servicing. Regular cleaning will reveal loose or worn parts and enhance the smooth operation of your wheelchair. To operate properly and safely, your wheelchair must be cared for just like any other vehicle. Routine maintenance will extend the life and efficiency of your wheelchair.

Initial adjustments should be made to suit personal body structure/preference. Thereafter follow these maintenance procedures:

	INITIALLY	INSPECT/ ADJUST WEEKLY	INSPECT/ ADJUST MONTHLY	INSPECT/ ADJUST PERIODICALLY
GENERAL ● Wheelchair rolls straight (no excessive drag or pull to one side).	X	X		X
SEAT AND BACK (PROCEDURE 3) ● Inspect for rips or sagging. ● Inspect for loose or broken hardware.	X X		X	X
REAR WHEELS (PROCEDURE 4) ● No excessive side movement or binding when lifted and spun.	X			X
HANDRIMS (PROCEDURE 4) ● Inspect for signs of rough edges or peeling.	X			X
SPOKES ● Inspect for broken spokes.	X	X		
FRONT CASTER (PROCEDURE 5) ● Inspect wheel/fork assembly for proper tension by spinning caster; caster should come to a gradual stop. ● Loosen/tighten locknut if wheel wobbles noticeably or binds to a stop.	X X	X	X	
● Wheel bearings are clean and free of moisture. CAUTION: As with any vehicle, the wheels and tires should be checked periodically for cracks and wear, and should be replaced.	X		X	X
TIRES ● Inspect for flat spots and wear. ● If pneumatic tires, check for proper inflation. CAUTION: As with any vehicle, the wheels and tires should be checked periodically for cracks and wear, and should be replaced.	X X			
WHEEL LOCKS (PROCEDURE 7) ● Do not interfere with tires when rolling. ● Pivot points free of wear and looseness. ● Wheel locks easy to engage.	X X X	X X	X	X
CLEANING ● Clean upholstery and armrests.	X			X

TROUBLESHOOTING

T
R
O
U
B
L
E
S
H
O
O
T
I
N
G

CHAIR VEERS LEFT/RIGHT	SLUGGISH TURN/ PERFORMANCE	CASTERS FLUTTER	SQUEAKS AND RATTLES	LOOSENESS IN CHAIR	CHAIR 3 WHEELS	SOLUTIONS
X	X	X			X	If pneumatic, check tires for correct and equal pressure.
X	X	X	X	X		Check for loose stem nuts/bolts.
X		X				Check that both casters contact ground at the same time.

MAINTENANCE

MAINTENANCE SAFETY PRECAUTIONS

WARNING

After ANY adjustments, repair or service and BEFORE use, make sure all attaching hardware is tightened securely - otherwise injury or damage may result.

CAUTION

DO NOT overtighten hardware attaching to the frame. This could cause damage to the frame tubing.

WARNING

DO NOT use the wheelchair unless it has the proper tire pressure (p.s.i.). DO NOT overinflate the tires. Failure to follow these suggestions may cause the tire to explode and cause bodily harm.

SUGGESTED MAINTENANCE PROCEDURES

1. Before using your Tracer Series wheelchair, make sure all nuts and bolts are tight. Check all parts for damage or wear and replace. Check all parts for proper adjustment.

2. If tires are pneumatic, recommended tire pressure is listed on the side wall of the tire.
3. The wheels and tires should be checked periodically for cracks and wear, and should be replaced when necessary by your authorized dealer or by a qualified technician.
4. Periodically check handrims to ensure they are securely attached to the rear wheels. Refer to REPLACING REAR WHEEL HANDRIM in PROCEDURE 4 of this manual.
5. Periodically adjust wheel locks in correlation to tire wear. Refer to WHEEL LOCK ADJUSTMENT in PROCEDURE 7 of this manual.
6. Periodically check front caster and rear wheel hubs to make sure they are clean.
7. Check Upholstery for sagging, rips or tears.

M
A
I
N
T
E
N
A
N
C
E

This Procedure includes the following:

Swingaway Footrest Assembly Installation

Swingaway Footrest Height Adjustment

Heel Loop Replacement

Elevating Legrest Assembly Installation

Adjusting the Elevating Legrest Assembly

WARNING

After ANY adjustments, repair or service and BEFORE use, make sure all attaching hardware is tightened securely - otherwise injury or damage may result.

SWINGAWAY FOOTREST ASSEMBLY INSTALLATION (FIGURE 1)

1. Turn the footrest to the side (open footplate is perpendicular to wheelchair).
2. Install the hinge plates on the footrest onto the hinge pins on the wheelchair frame.
3. Push the footrest towards the inside of the wheelchair until it locks into place.

NOTE: The footplate will be on the inside of the wheelchair when locked in place.

4. Repeat this procedure for the other footrest assembly.
5. To release the footrest, push the footrest release lever inward, rotate footrest outward.

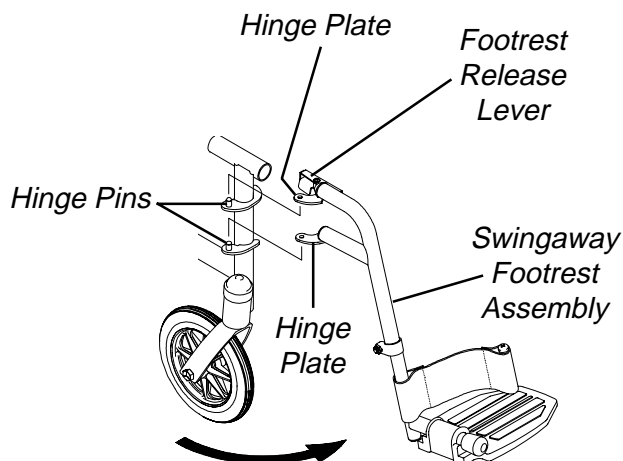

FIGURE 1 - SWINGAWAY FOOTREST ASSEMBLY INSTALLATION

SWINGAWAY FOOTREST HEIGHT ADJUSTMENT (FIGURE 2)

NOTE: Release the footrest locking mechanism and lift the footrest off of the hinge pins. Lay the assembly on a flat surface to simplify this procedure.

1. Remove impact guards and/or calf strap, if necessary.
2. Loosen, but do not remove the bolt and locknut that secure the lower footrest assembly to the upper footrest support.
3. Reposition the lower footrest assembly to the desired height.
4. Securely tighten the bolt and locknut.
5. Repeat this procedure for the other footrest, if necessary.
6. Replace impact guards and/or calf strap, if necessary.

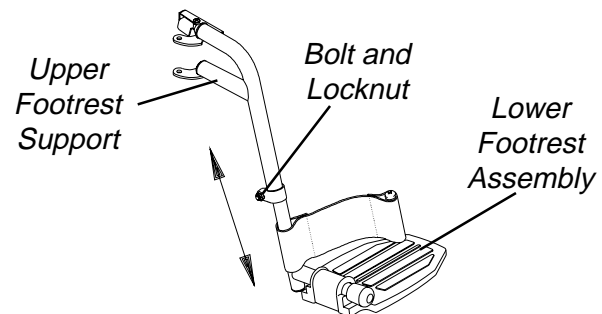

FIGURE 2 - SWINGAWAY FOOTREST HEIGHT ADJUSTMENT

HEEL LOOP REPLACEMENT (FIGURE 3)

NOTE: Heel loops are not available on Invacare MG wheelchairs.

1. Loosen, but do not remove the bolt and locknut that secure the lower half of the footrest to the swingaway footrest assembly.
2. Remove the lower footrest assembly.
3. Remove the phillips screw and locknut that secure the heel loop to the footrest.
4. Slide heel loop over cane of the footrest assembly.
5. Replace heel loop.
6. Reverse STEPS 1-5 to reassemble.

NOTE: When securing the heel loop to the footrest assembly, tighten the phillips screw and locknut until the spacer is secure.

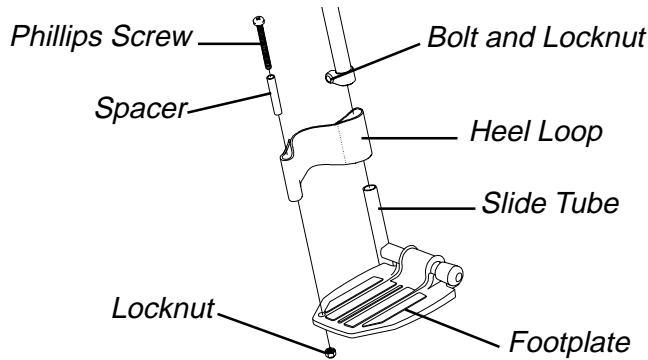

FIGURE 3 - HEEL LOOP REPLACEMENT

ELEVATING LEGREST ASSEMBLY INSTALLATION (FIGURE 4)

1. Place legrest assembly on the outside of the wheelchair and install the hinge plates onto the hinge pins on wheelchair frame (FIGURE 4).
2. Rotate legrest assembly toward the inside of the wheelchair until it locks in place (FIGURE 4).

NOTE: The footplate will be on the inside of the wheelchair when locked in place.

3. Repeat this procedure for other legrest assembly.
4. After seated in wheelchair, adjust footrest to correct height by loosening the locknut and sliding the lower footrest assembly tube up or down until desired height is achieved.
5. Tighten locknut securely.

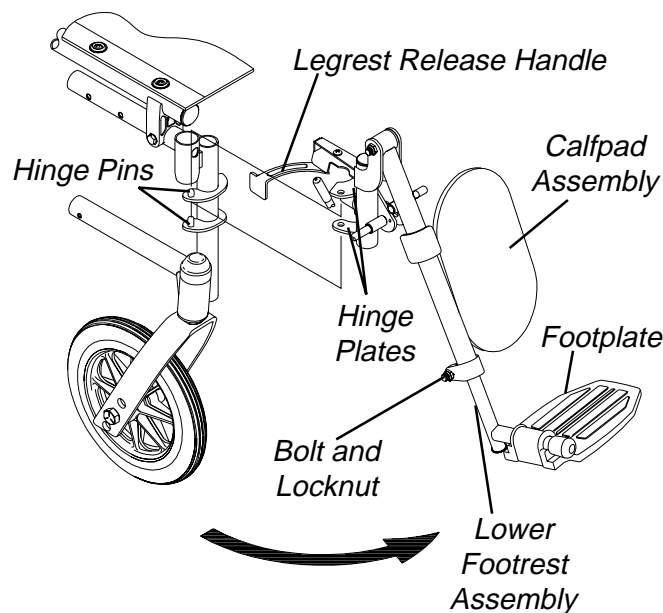

FIGURE 4 - ELEVATING LEGREST INSTALLATION

6. To release the legrest, push the legrest release handle toward the inside of the wheelchair (**facing the front of the wheelchair**) and swing the legrest assembly to the outside of the wheelchair.

ADJUSTING THE ELEVATING LEGREST ASSEMBLY (FIGURE 5)

NOTE: Adjustments to Articulating Legrests and Fixed Front End Legrests are performed in the same fashion as the elevating legrest.

1. To adjust the elevating legrest, raise legs until the desired height is obtained.
2. To reposition legrest to normal position, support leg with one (1) hand and push release lever downward with other hand.
3. To adjust the calfpad, turn pad towards the outside of the wheelchair.
4. Slide the calfpad up or down until the desired position is obtained.
5. To secure the calfpad, turn the calfpad towards the inside of the wheelchair.

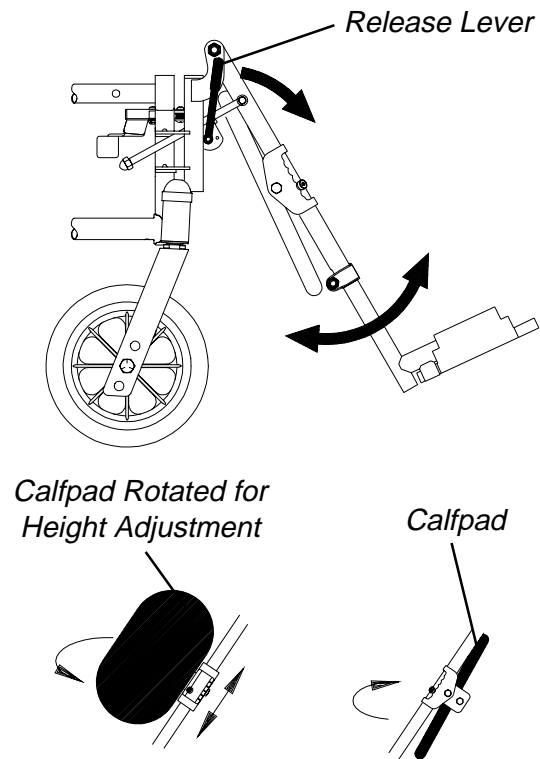

FIGURE 5 - ADJUSTING THE ELEVATING LEGREST ASSEMBLY

This Procedure Includes the Following:**Removing or Replacing Standard Armrest****Adjusting Armrest Height - Adjustable Height Arms Only****Using or Replacing Flip-Back Armrest****WARNING**

After ANY adjustments, repair or service and BEFORE use, make sure all attaching hardware is tightened securely - otherwise injury or damage may result.

Make sure the armrest is securely locked into the arm socket BEFORE using the wheelchair.

REMOVING OR REPLACING STANDARD ARMREST (FIGURE 1)

1. Press in armrest release button located on armrest.
2. Pull straight up to remove armrest from arm sockets.
3. Replace armrest by reversing STEPS 1-2.

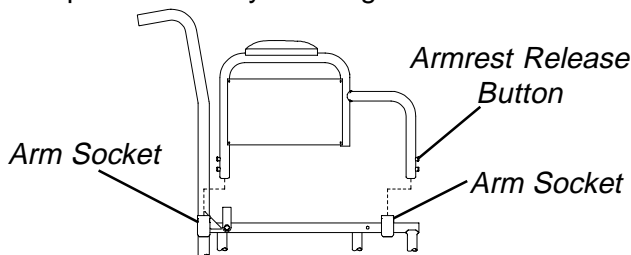

FIGURE 1 - REMOVING OR REPLACING STANDARD ARMREST

USING OR REPLACING FLIP-BACK ARMREST (FIGURE 3)**WARNING**

DO NOT operate or replace flip-back armrest when wheelchair is folded.

Using

1. Press in armrest release button located on armrest front tube.
2. Rotate front of armrest UP and BACK and out of arm socket.
3. Reverse STEP 2 to replace armrest to DOWN position.
4. Position the front of the armrest into the arm socket.
5. Ensure armrest is securely locked into arm socket and snap button locks into place BEFORE using.

Replacing

1. Perform STEPS 1-2 above to flip the armrest back.
2. Remove bolt, washer, spacer and locknut securing armrest to wheelchair frame.
3. Remove armrest from frame.
4. Position new insert into new rear armrest tube, aligning the mounting holes.

ADJUSTING ARMREST HEIGHT - ADJUSTABLE HEIGHT ARMS ONLY (FIGURE 2)

1. Unlock the armrest by flipping the height adjustment lever on the top front of the armrest to the UP (HORIZONTAL) position.

2. Adjust armrest to desired height.

NOTE: Height adjustment lever MUST be in the unlocked position when placing armrest into the arm assembly.

3. Lock the armrest by pressing the height adjustment lever into the DOWN (VERTICAL) position when the desired armrest height is achieved.

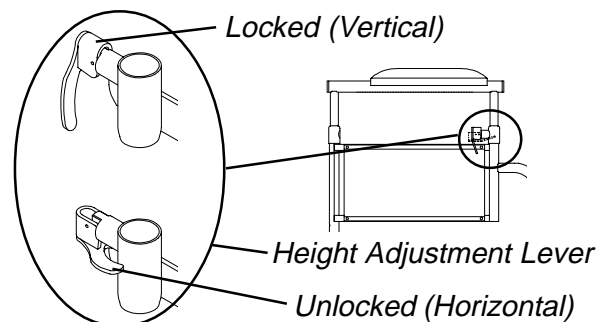

FIGURE 2 - ADJUSTING ARMREST HEIGHT - ADJUSTABLE HEIGHT ARMS ONLY

5. Insert the new bolt through the armrest mounting bracket, new washer, new spacer and new armrest rear tube, as shown in FIGURE 3.

NOTE: Ensure the spacer sits flush against the armrest.

6. Install nut onto bolt. Torque to 55-60in./lbs.

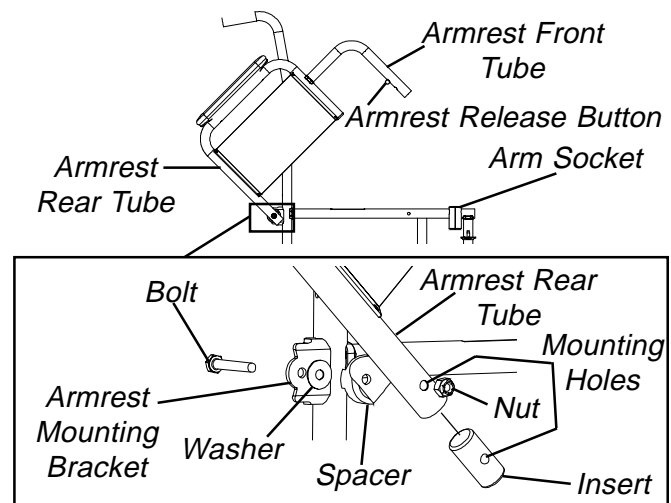

FIGURE 3 - USING OR REPLACING FLIP-BACK ARMREST

This Procedure Includes the Following:
Fold Down Back - Tracer Transport Only
Replacing Back Upholstery
Replacing the Seat Upholstery
Adjusting Seat Width

WARNING

After ANY adjustments, repair or service and BEFORE use, make sure all attaching hardware is tightened securely - otherwise injury or damage may result.

FOLD DOWN BACK - TRACER TRANSPORT ONLY (FIGURE 1)

Folding

1. Lift up on the two (2) release levers on the back canes.
2. Pull back on the handles to the desired position.

Unfolding

WARNING

Make sure the release levers are securely locked in place BEFORE using the wheelchair.

1. Pull up on the two (2) back canes until the release levers lock in place.

NOTE: There will be an audible click.

2. Pull on the handles to make sure the back is locked in place.

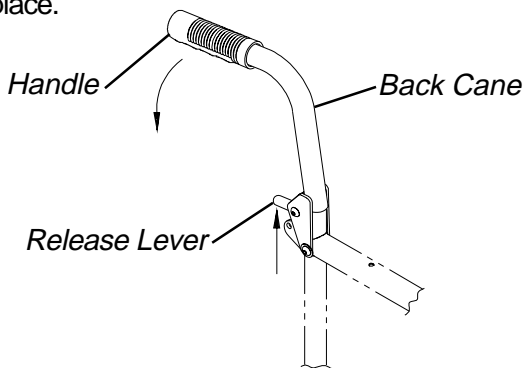

FIGURE 1 - FOLD DOWN BACK - TRACER TRANSPORT ONLY

REPLACING THE BACK UPHOLSTERY (FIGURE 2)

1. Remove the screws and washers that secure the existing back upholstery to the back canes.
2. Position new back upholstery on back canes as shown in FIGURE 2.

3. Securely tighten the new back upholstery to the back canes with the screws and washers.

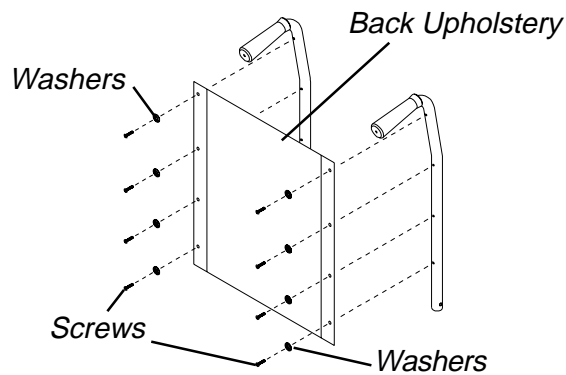

FIGURE 2 - REPLACING BACK UPHOLSTERY

REPLACING THE SEAT UPHOLSTERY (FIGURE 3)

1. Remove the eight (8) screws that secure the existing seat upholstery to the crossbraces.
2. Remove the existing seat upholstery from the crossbraces.
3. Install the new seat upholstery by reversing STEPS 1-2.

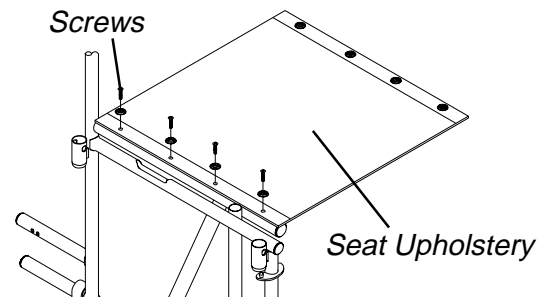

FIGURE 3- REPLACING THE SEAT UPHOLSTERY

ADJUSTING SEAT WIDTH

WARNING

Adjusting the seat width of the wheelchair **MUST** be performed by an authorized Invacare dealer or qualified technician.

Removing Lower Mounting Hardware (FIGURE 4)

1. Remove the existing back and seat upholstery from the wheelchair. Refer to REPLACING THE BACK UPHOLSTERY and REPLACING THE SEAT UPHOLSTERY in this section of the manual.

NOTE: If adjusting the seat width of the wheelchair, back and seat upholstery as well as the crossbraces MUST be replaced.

2. Remove the four (4) screws and locknuts that secure the insert tube to the lower wheelchair frame.

3. Remove the inserts from the rear of the wheelchair.
4. Remove the hex screw and locknut that secure the two (2) existing crossbraces together.

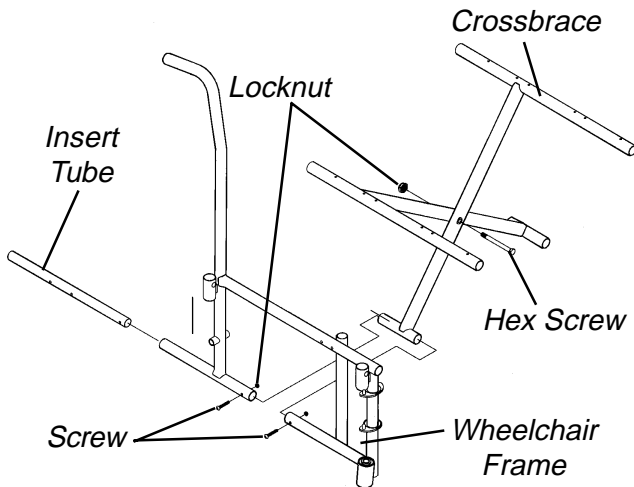

FIGURE 4 - REMOVING LOWER MOUNTING HARDWARE

Removing Upper Mounting Hardware

1. Perform one (1) of the following:
 - ALL PERMANENT ARM WHEELCHAIRS (FIGURE 5).**
 - a. While pushing down on the rear seat guide, pull up the front seat guide until the front seat guide releases from the wheelchair frame.
 - b. Pull the crossbrace away from the rear seat guide.
 - c. Repeat STEPS a-b for opposite crossbrace.
 - d. Reverse STEPS a-c to assemble the upper mounting hardware.
 - e. Reverse STEPS 1-5 in REMOVING LOWER MOUNTING HARDWARE in this section of the manual to reassemble the wheelchair.

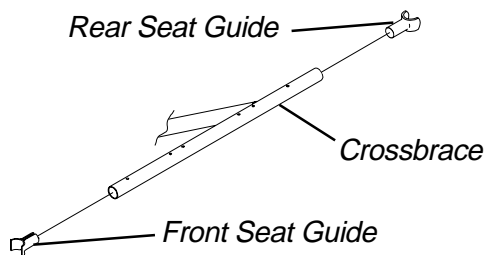

FIGURE 5 - ALL PERMANENT ARM WHEELCHAIRS

ALL REMOVABLE ARM WHEELCHAIRS - EXCEPT TRACER IV (FIGURE 6).

- a. Pull up on the crossbrace until the front seat guide is removed from the wheelchair.
- b. Remove the two (2) spacers and front seat guide from the crossbrace.

- c. Pull the crossbrace away from the rear seat guide.
- NOTE: Seat guide will remain attached to back tube.*
- d. Repeat STEPS a-c for opposite crossbrace.
 - e. Reverse STEPS a-d to assemble the upper mounting hardware.
 - f. Reverse STEPS 1-5 in REMOVING LOWER MOUNTING HARDWARE in this section of the manual to reassemble the wheelchair.

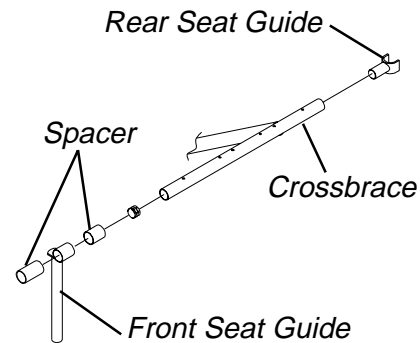

FIGURE 6 - ALL REMOVABLE ARM WHEELCHAIRS - EXCEPT TRACER IV

TRACER IV (FIGURE 7).

- a. Pull up on the crossbrace until the front and rear seat guides are removed from the wheelchair.
- b. Remove the end cap, two (2) seat guides and spacer from the crossbrace.
- c. Repeat STEPS a-b for opposite crossbrace.
- d. Reverse STEPS a-c to assemble the upper mounting hardware.
- e. Reverse STEPS 1-5 in REMOVING LOWER MOUNTING HARDWARE in this section of the manual to reassemble the wheelchair.

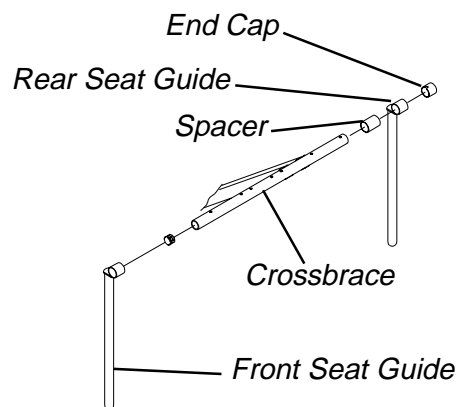

FIGURE 7 - TRACER IV

This Procedure Includes the Following:
 Removing/Installing the Rear Wheels
 Replacing Rear Wheel Handrim
 Replacing/Repairing Rear Wheel Tire/Tube

WARNING
 After ANY adjustments, repair or service and BEFORE use, make sure all attaching hardware is tightened securely - otherwise injury or damage may result.

REMOVING/INSTALLING THE REAR WHEELS (FIGURE 1)

1. Remove the dust cap, hex screw and locknut that secure the rear wheel and axle spacer to the wheelchair.
2. Repeat STEP 1 for the opposite rear wheel.
3. To reinstall the rear wheel onto the wheelchair, reverse STEPS 1-2.

NOTE: Make sure axle spacer is between rear wheel and wheelchair frame.

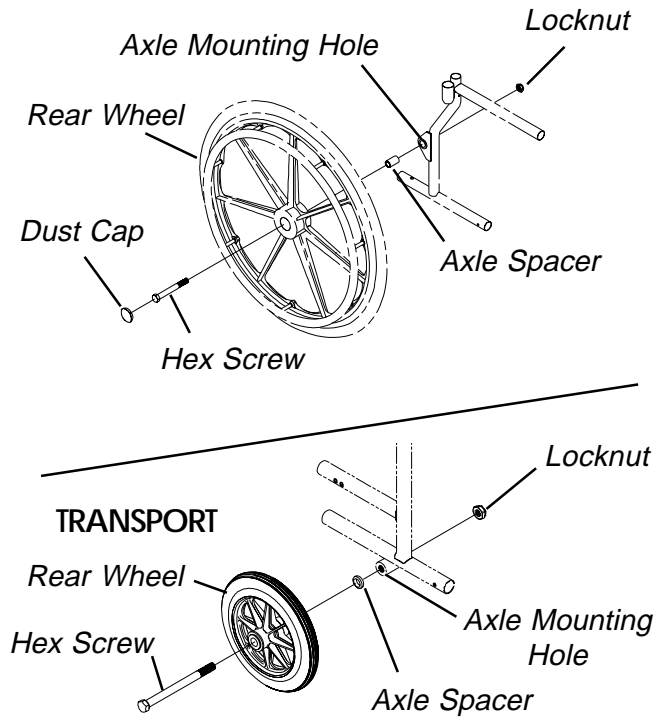

FIGURE 1 - REMOVING/INSTALLING THE REAR WHEELS

REPLACING REAR WHEEL HANDRIM (FIGURE 2)

1. Remove the rear wheel from the wheelchair.
2. Remove the button screws and washers that secure the handrim to the rear wheel.
3. Remove the existing handrim.
4. Install the new handrim by reversing STEP 1-3.
5. Repeat the procedure for the opposite rear wheel if necessary.

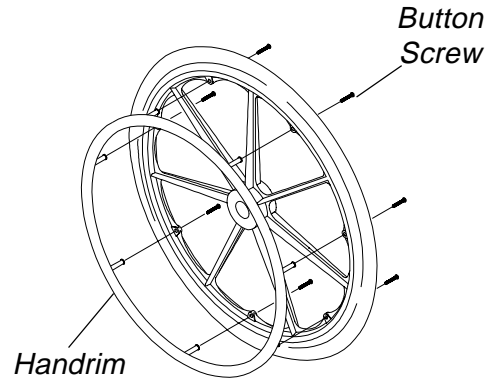

FIGURE 2 - REPLACING REAR WHEEL HANDRIM

REPLACING/REPAIRING REAR WHEEL TIRE/TUBE

WARNING
 Replacement of rear wheel tire or tube **MUST** be performed by an authorized Invacare dealer or qualified technician.

CAUTION
 As with any vehicle, the wheels and tires should be checked periodically for cracks and wear, and should be replaced.

This Procedure Includes the Following:
Installing/Replacing Six or Eight-inch Front Casters and Forks
Adjusting Front Forks
Replacing/Repairing Front Caster Tire/Tube
Replacing Front Casters

WARNING
 After ANY adjustments, repair or service and BEFORE use, make sure all attaching hardware is tightened securely - otherwise injury or damage may result.

INSTALLING/REPLACING SIX OR EIGHT-INCH FRONT CASTERS AND FORKS (FIGURE 1)

1. Remove the caster from the fork. Refer to REPLACING FRONT CASTERS in this section of the manual.
2. Remove the dust cover.
3. Remove the locknut and nylon washer that secure the fork to the caster headtube.
4. Drop the fork out of the caster headtube.
5. Slide the new fork into the caster headtube and re-assemble by reversing STEPS 1-4.
6. Adjust the forks. Refer to ADJUSTING FORKS in this section of the manual.
7. Repeat STEPS 1-6 for opposite fork, if necessary.

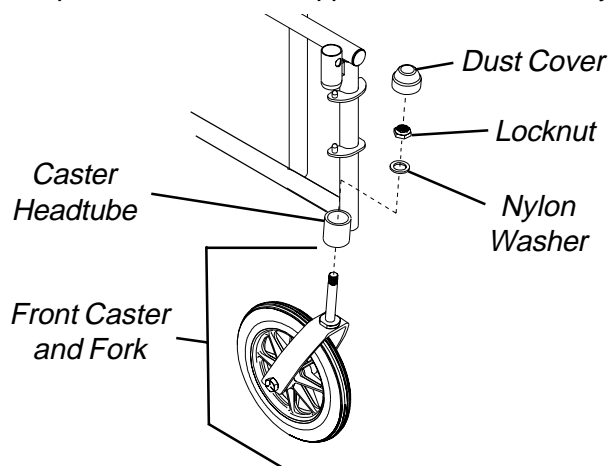

FIGURE 1 - INSTALLING/REPLACING SIX OR EIGHT-INCH FRONT CASTERS AND FORKS

ADJUSTING FORKS (FIGURE 1)

1. Remove the dust cover.
2. To properly tighten caster journal system and guard against flutter, perform the following check:

- a. Tip back the wheelchair to floor.
 - b. Pivot both forks and casters to top of their arc simultaneously.
 - c. Let casters drop to bottom of arc (wheels should swing once to one-side, then immediately rest in a straight downward position).
 - d. Adjust locknuts according to freedom of caster swing.
3. Test wheelchair for maneuverability.
 4. Readjust locknuts if necessary, and repeat STEPS 2-3 until correct.
 5. Snap dust cover over the locknut and stem.

REPLACING/REPAIRING FRONT CASTER TIRE/TUBE

WARNING
 Replacement of front caster tire or tube **MUST** be performed by an authorized Invacare dealer or qualified technician.

CAUTION
 As with any vehicle, the wheels and tires should be checked periodically for cracks and wear, and should be replaced.

REPLACING FRONT CASTERS (FIGURE 2)

1. Remove the hex screw, washers and locknut that secure the front caster to the fork.
- NOTE: Washers are used on TRACER IV wheelchairs only.*
2. Install the new front caster onto the wheelchair by reversing STEP 1.
 3. Repeat STEPS 1-2 for the opposite front caster if necessary.

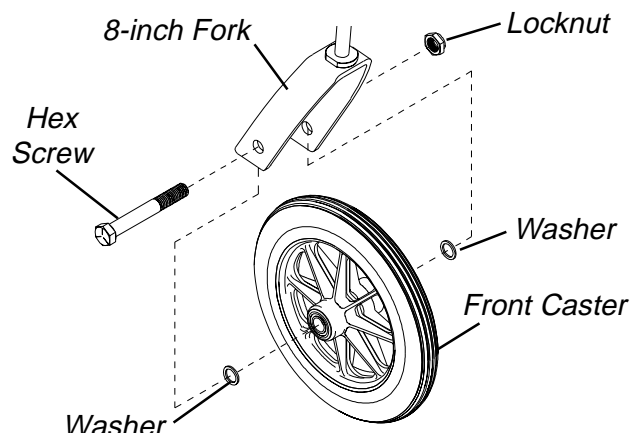

FIGURE 2 - REPLACING FRONT CASTERS

DEALER ADJUSTMENTS

This Procedure Includes the Following:
Changing Seat-To-Floor Height-Tracer EX Only

WARNING
 After ANY adjustments, repair or service and BEFORE use, make sure all attaching hardware is tightened securely - otherwise injury or damage may result.

NOTE: Tracer IV, Tracer Transport and Invacare MG: Seat to floor height not adjustable.

CHANGING SEAT-TO-FLOOR HEIGHT-TRACER EX ONLY (FIGURE 1)

WARNING
 When changing the seat-to-floor height you must adjust the anti-tippers accordingly.

NOTE: Invacare recommends that the following procedure be performed by an authorized dealer or qualified technician.

1. Remove the rear wheels from the wheelchair. Refer to REMOVING/INSTALLING THE REAR WHEELS in PROCEDURE 4 of this manual.
2. Remove the front casters from the wheelchair. Refer to INSTALLING/REPLACING SIX OR EIGHT INCH FRONT CASTERS & FORKS in PROCEDURE 5 of this manual.
3. Refer to the charts of front caster/fork and rear wheel sizes, to determine mounting positions for obtainable seat-to-floor heights in FIGURE 1.
4. Reinstall the front casters onto the wheelchair. Refer to INSTALLING/REPLACING SIX OR EIGHT INCH FRONT CASTERS & FORKS in PROCEDURE 5 of this manual.
5. Reinstall the rear wheels onto the wheelchair. Refer to REMOVING/INSTALLING THE REAR WHEELS in PROCEDURE 4 of this manual.
6. Adjust anti-tippers as necessary. Refer to ADJUSTING THE ANTI-TIPPERS in PROCEDURE 7 of this manual.

TRACER EX FRAME

Seat-to-Floor Height (In Inches)	Front Caster Size	Front Caster Mounting Position	Rear Wheel Size
21	8-inch	N/A	24-inch
21	6-inch	Bottom	24-inch
20	6-inch	Middle	22-inch
19	6-inch	Top	20-inch

NOTE: 6-inch and 8-inch casters require different forks.

8-INCH FORK MOUNTING POSITION

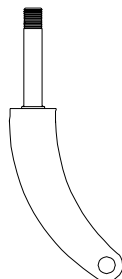

6-INCH FORK MOUNTING POSITIONS

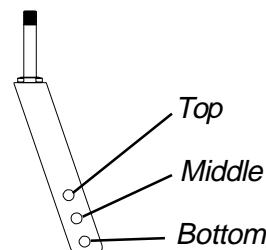

FIGURE 1 - CHANGING SEAT-TO-FLOOR HEIGHT - TRACER EX ONLY

This Procedure Includes the Following:
Installing/Adjusting Anti-Tippers
Wheel Lock Adjustment

WARNING
 After ANY adjustments, repair or service and BEFORE use, make sure all attaching hardware is tightened securely - otherwise injury or damage may result.

INSTALLING/ADJUSTING THE ANTI-TIPPERS

WARNING
 Inasmuch as the anti-tippers are an option on this wheelchair (You may order with or without the anti-tippers), Invacare strongly recommends ordering the anti-tippers as an additional safeguard for the wheelchair user.
 Anti-tippers MUST be fully engaged. Ensure that the release button of the anti-tipper fully protrudes out of the hole on the bottom of the wheelchair frame.
 Ensure both anti-tippers are adjusted to the same height.

Installing the Anti-tippers (FIGURES 1 and 2)

NOTE: To ensure the correct model anti-tipper is used refer to FIGURE 1. Measurements for anti-tippers are approximate and are taken with extension tube in TOP hole position.

NOTE: Anti-Tippers are not available on the Tracer Transport wheelchair.

Chair	Anti-tipper Length	Anti-tipper Model
EX with 24 and 22-inch rear wheels and the Invacare MG	12-inches	9758
EX with 20-inch rear wheels	11 1/4-inches	9859
Tracer IV	8 3/8-inches (non-adjustable)	1358m

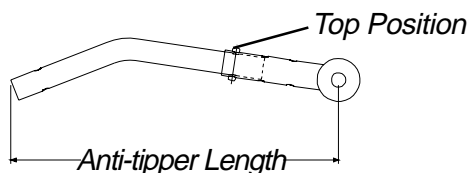

FIGURE 1 - ANTI-TIPPER LENGTH

1. Depress the release buttons and insert the anti-tippers with the anti-tipper wheels pointing toward the ground/floor into the wheelchair frame tubing as shown in FIGURE 2.
2. Ensure that the release button of the anti-tipper fully protrudes out of the hole in the bottom of the wheelchair frame tubing.
3. Adjust anti-tippers as necessary. Refer to ADJUSTING THE ANTI-TIPPERS in this section of the manual.

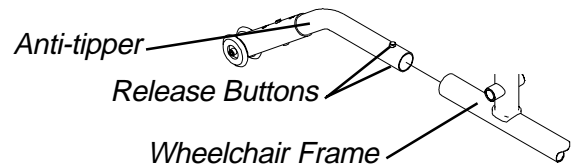

FIGURE 2 - INSTALLING THE ANTI-TIPPERS

Adjusting The Anti-tippers (FIGURE 3)

NOTE: A 1-1/2 to 2-inch clearance between the bottom of the anti-tipper wheels and the ground/floor MUST be maintained at all times.

1. Place wheelchair on a flat, level surface.
2. Press the release buttons near the wheeled portion of the anti-tipper and slide it up or down to achieve the 1-1/2 to 2-inch clearance (FIGURE 3).
3. Check to make sure that the release buttons are fully engaged in adjustment holes, and ensure both anti-tippers are adjusted to the same height.
4. Check to make sure that a 1-1/2 to 2-inch clearance between the bottom of the anti-tipper wheels and the ground/floor has been achieved BEFORE using the wheelchair.
5. Repeat STEPS 1-3 until 1-1/2-2-inch clearance is achieved.

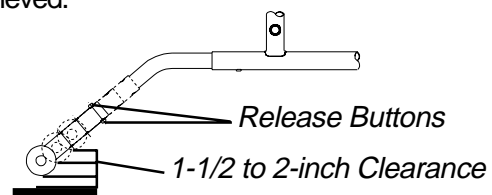

FIGURE 3 - ADJUSTING THE ANTI-TIPPERS

**WHEEL LOCK ADJUSTMENT
(FIGURE 4)**

NOTE: Before adjusting or replacing the wheel lock assemblies, ensure that the tires are inflated to the recommended psi on the side wall of tire.

1. Loosen the bolt and locknut that secure the wheel lock assembly to the wheelchair frame.
2. Adjust the position of wheel lock until the measurement between the rear wheel and the wheel lock shoe is between 5/32 and 5/16-inches.
3. Securely tighten the bolt and locknut.
4. Engage wheel lock and push against the wheelchair and determine if wheel lock engages the wheel lock shoe enough to hold the wheelchair.
5. Repeat the above procedures until the wheel lock holds the wheelchair.
6. Repeat STEPS 1-5 for the opposite wheel lock.

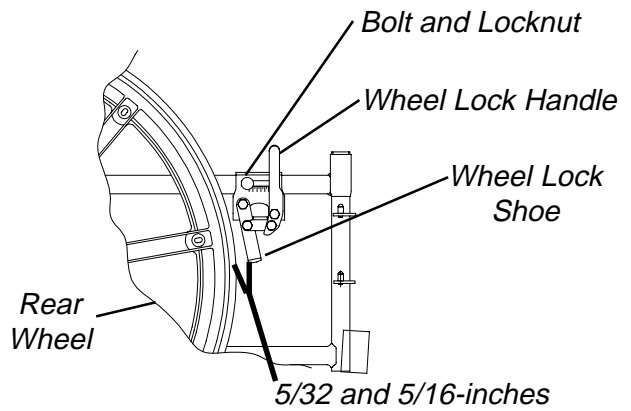

FIGURE 4 - WHEEL LOCK ADJUSTMENT

ANTI-TIPPERS
WHEEL LOCKS

- This Procedure Includes the Following:**
- Installing the Amputee Attachment**
 - Installing Fixed Height I.V. Rod**
 - Installing the Carrying Pocket**
 - Installing the Seat Positioning Strap**
 - Installing/Adjusting the Front Anti-Tippers**
 - Installing the Anti-Theft Device**
 - Installing the Telescoping I.V. Rod**

WARNING
 After ANY adjustments, repair or service and BEFORE use, make sure all attaching hardware is tightened securely - otherwise injury or damage may result.

INSTALLING THE AMPUTEE ATTACHMENT (FIGURE 1)

1. Remove the end cap or anti-tipper from the end of the wheelchair.
2. Slide the amputee attachment over the step tube of the wheelchair.
3. Secure the amputee attachment to the wheelchair with the hex screw, spacer and locknut.
4. Reinstall the end cap or anti-tipper onto the end of the wheelchair.
5. Repeat STEPS 1-4 for the opposite side of the wheelchair.
6. Reposition the rear wheels. Refer to REMOVING/INSTALLING REAR WHEELS in PROCEDURE 4 of this manual.

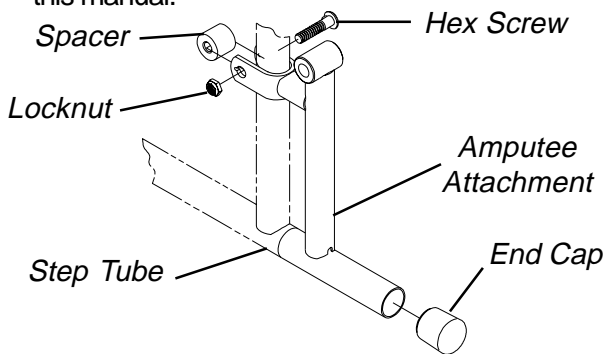

FIGURE 1 - INSTALLING THE AMPUTEE ATTACHMENT

INSTALLING FIXED HEIGHT I.V. ROD (FIGURE 2)

1. Remove the top two (2) back upholstery screws from the side of the wheelchair that the socket mount was designed.

2. Position the socket mount on the wheelchair frame as shown in FIGURE 2.
3. Secure the socket mount to the wheelchair frame with the two (2) back upholstery screws.

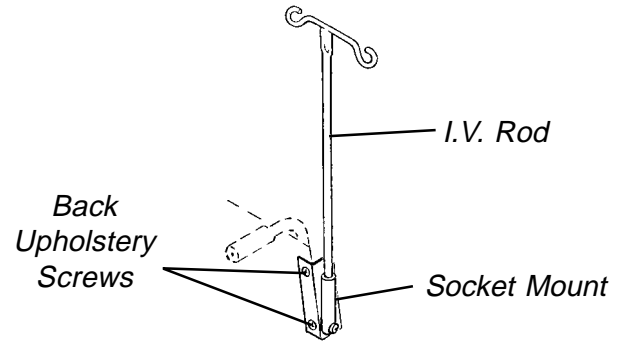

FIGURE 2 - INSTALLING FIXED HEIGHT I.V. ROD

INSTALLING THE CARRYING POCKET (FIGURE 3)

1. Determine the height required for the carrying pocket.
2. Remove the two (2) back upholstery screws and two (2) washers that correspond to the desired height.
3. Center pouch against back canes, determine and mark location for mounting holes on carrying pouch straps.
4. Punch holes in straps.
5. Fold excess strap ends under, mark mounting holes in second thickness of strap and punch mounting holes.
6. Fold strap ends under so the upholstery screw can be inserted through two (2) thicknesses of strap.
7. Position the carrying pocket on the wheelchair frame.
8. Secure the carrying pocket to the wheelchair frame with the two (2) washers two (2) back upholstery screws.

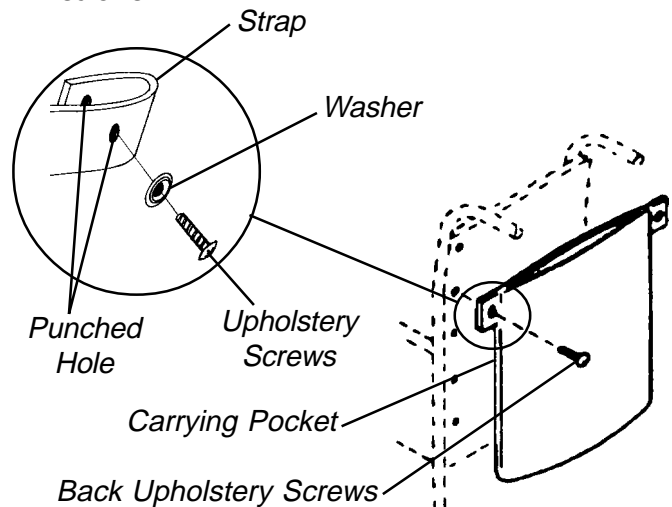

FIGURE 3- INSTALLING THE CARRYING POCKET

INSTALLING THE SEAT POSITIONING STRAP (FIGURE 4)

WARNING

ALWAYS wear your positioning strap. Inasmuch as the SEAT POSITIONING STRAP is an option on this wheelchair (You may order with or without the seat restraint), Invacare strongly recommends ordering the SEAT POSITIONING STRAP as an additional safeguard for the wheelchair user.

1. Remove the bottom back upholstery screw from the wheelchair.
2. Position the seat positioning strap half between the back cane and back upholstery.
3. Secure the back upholstery and seat positioning strap to the wheelchair with the existing back upholstery screw.
4. Repeat STEPS 1-3 for the opposite side of the wheelchair.

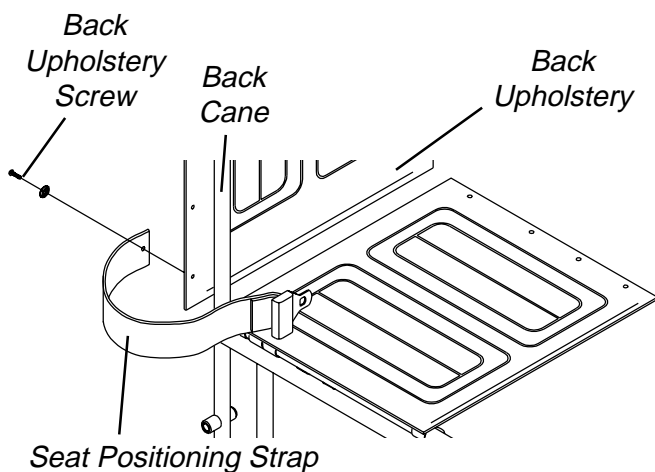

FIGURE 4- INSTALLING THE SEAT POSITIONING STRAP

INSTALLING/ADJUSTING THE FRONT ANTI-TIPPERS (FIGURE 5)

Front anti-tippers are a safe convenient way to help prevent the wheelchair from tipping forward. The anti-tipper "triangle" is always in the downward position; when pivoted it will swing to clear obstructions.

WARNING

Front anti-tippers are recommended by Invacare when using elevating legrests. Even though a wheelchair is equipped with front anti-tippers, individuals should be taught to elevate legrests, swing front riggings aside and/or flip up footplates so they are out of the way BEFORE placing feet firmly on the floor when entering or exiting the wheelchair. This will permit individuals to stand close to front edge of the seat and lower himself/herself well enough back onto the seat.

Ensure Front Anti-Tippers are adjusted to the same height - otherwise the wheelchair may tip to one side and injury or damage may occur.

Installing Front Anti-Tippers

CAUTION

When securing the front anti-tippers to the wheelchair frame. DO NOT overtighten the attaching hardware, otherwise damage to the wheelchair frame may occur.

1. Remove the locknuts and the lug bolts from the anti-tipper bracket clamps.
2. Position the anti-tipper bracket clamp over the wheelchair frame behind the front caster as shown in FIGURE 5.

NOTE: Position the anti-tipper arm on the outside of the wheelchair as shown in FIGURE 5.

3. Squeeze bracket clamps together and insert the bolts.
4. Install the locknuts onto the lug bolts. Tighten securely.
5. Repeat STEPS 1-4 on the opposite side of the wheelchair for the remaining anti-tipper.
6. Measure from the floor to the bottom of the wheels of the triangular assembly.
7. Perform one (1) of the following:

TRIANGULAR ASSEMBLY 3/4-INCH FROM FLOOR - Repeat STEPS 1-2 for the opposite triangular assembly.

TRIANGULAR ASSEMBLY NOT 3/4-INCH FROM FLOOR - Adjust the height of the triangular assemblies. Refer to ADJUSTING FRONT ANTI-TIPPERS in this section of the manual.

Adjusting Front Anti-tippers

1. Measure from the floor to the bottom of the wheels of the triangular assembly.
2. Perform one (1) of the following:
TRIANGULAR ASSEMBLY 3/4-INCH FROM FLOOR - Repeat STEP 1 for the opposite triangular assembly.
TRIANGULAR ASSEMBLY NOT 3/4-INCH FROM FLOOR - Proceed to STEP 3.
3. Remove the machine screw, washers and locknut securing the triangular assembly to the bottom of the anti-tipper arm.
4. Position the triangular assembly mounting hole to align with one (1) of the adjustment holes in the anti-tipper arm.
5. Measure from the floor to the bottom of the wheels of the triangular assembly.

6. Repeat STEPS 4-5 until the bottom of the wheels of the triangular assembly measure approximately 3/4-inch from the floor.
7. Secure the triangular assembly to the bottom of the anti-tipper arm with the machine screw, washers and locknut.

WARNING

DO NOT overtighten the locknut securing the triangular assembly to the bottom of the anti-tipper arm. Otherwise, anti-tipper arm will not swing freely and the wheelchair may tip over, resulting in injury or damage.

8. Tighten the locknut until the triangular assembly does not rattle, but swings freely at the end of the anti-tipper arm.
9. Repeat STEPS 1-2 for the opposite triangular assembly.

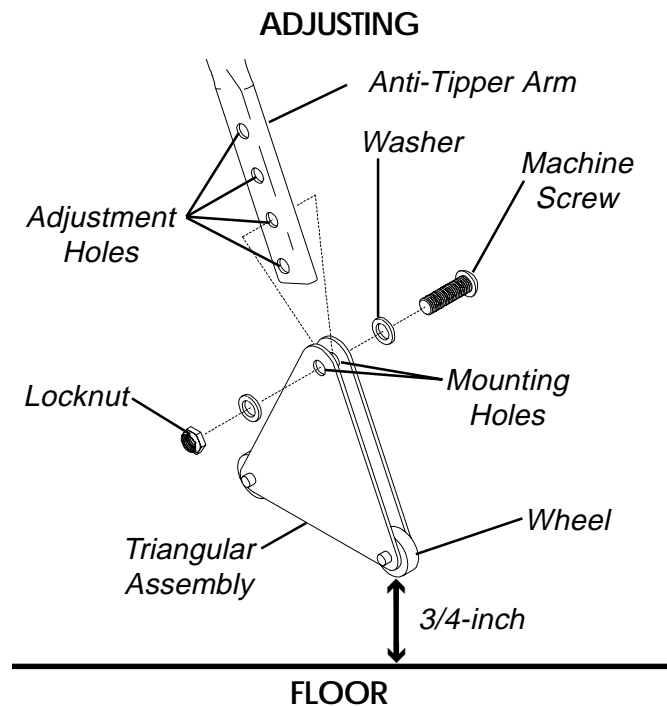
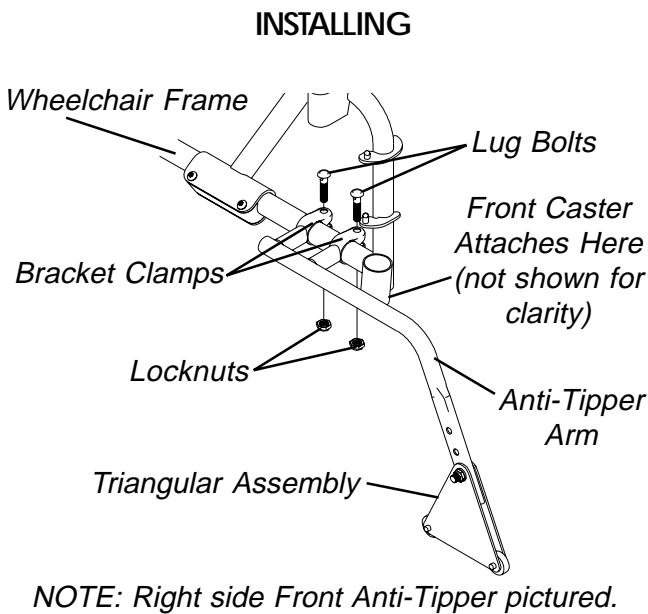

FIGURE 5 - INSTALLING/ADJUSTING THE FRONT ANTI-TIPPERS

INSTALLING THE TELESCOPING I.V. ROD

NOTE: Flip-back style arms will not flip back when used on the same side of the wheelchair as the telescoping I.V. rod.

Installing The telescoping I.V. Rod on Non-Transport Wheelchairs Only (FIGURE 1)

1. Determine if the telescoping I.V. rod will be mounted on the right or left side of the wheelchair.

NOTE: The telescoping I.V. rod is factory set for installation onto either the right side of a wheelchair with back upholstery mounted to the front of the back canes OR the left side of a wheelchair with back upholstery mounted to the back of the back canes. Refer to REPOSITIONING THE UPPER ATTACHMENT in this instruction sheet if any other mounting position is desired.

2. Position the I.V. rod mounting bracket on the step tube on the side determined in STEP 1.
3. Loosely install the lug screw, spacer and locknut that secure the mounting bracket to the back cane.
4. Remove the top phillips screw and washer from the back upholstery.
5. Line up the mounting holes in the back cane, back upholstery and upper attachment.
6. Reinstall the washer and phillips screw and securely tighten.
7. Securely tighten all attaching hardware.
8. Loosen the adjustment knob and position the I.V. rod to the desired height and securely tighten the adjustment knob.

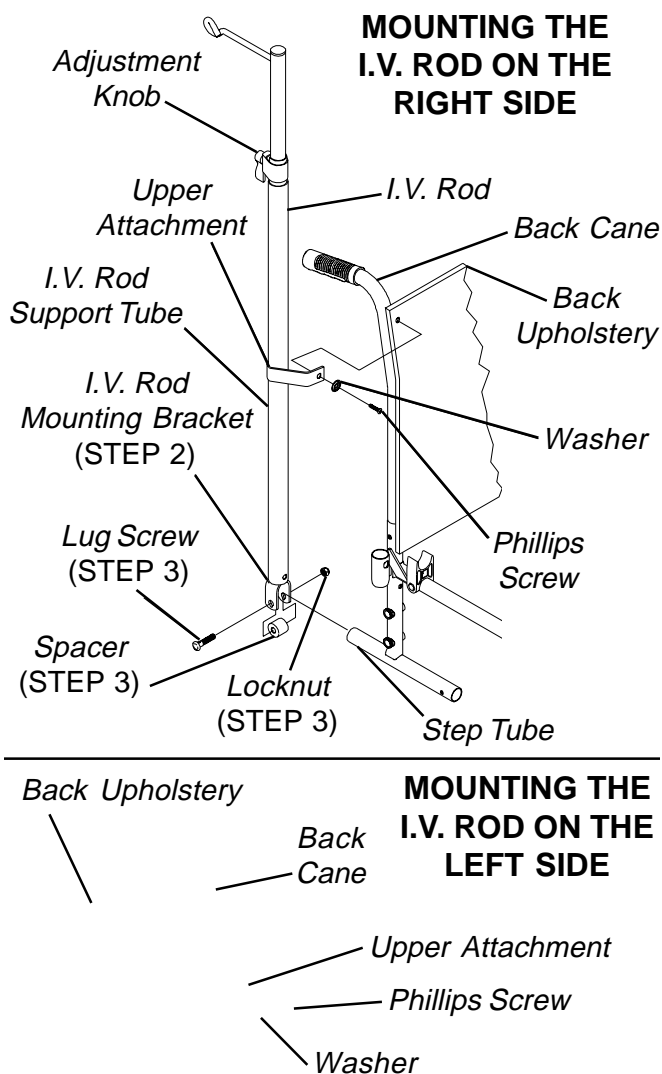

FIGURE 1 - INSTALLING THE TELESCOPING I.V. ROD ON NON-TRANSPORT WHEELCHAIRS ONLY

Installing The telescoping I.V. Rod on Transport Wheelchairs Only (FIGURE 2)

1. Determine if the telescoping I.V. rod will be mounted on the right or left side of the wheelchair.

NOTE: The telescoping I.V. rod is factory set for installation onto the left side of a wheelchair. Refer to REPOSITIONING THE UPPER ATTACHMENT in this instruction sheet if any other mounting position is desired.

NOTE: If installing the telescoping I.V. rod on a wheelchair Equiped with a short upper step tube, ensure the step tube protrudes 1/2-inch or more through the I.V. rod mounting bracket.

2. Position the I.V. rod mounting bracket on the upper step tube on the side determined in STEP 1.
3. Loosely install the lug screw, spacer and locknut that secure the mounting bracket to the wheelchair frame.
4. Locate the back upholstery mounting screw and washer second down from the top of the back cane and remove as shown in FIGURE 2. Set upholstery mounting screw and washer aside.
5. Line up the mounting holes in the back cane, back upholstery and upper attachment.
6. Reinstall the washer and back upholstery mounting screw and securely tighten.
7. Securely tighten all attaching hardware.
8. Loosen the adjustment knob and position the I.V. rod to the desired height and securely tighten the adjustment knob.

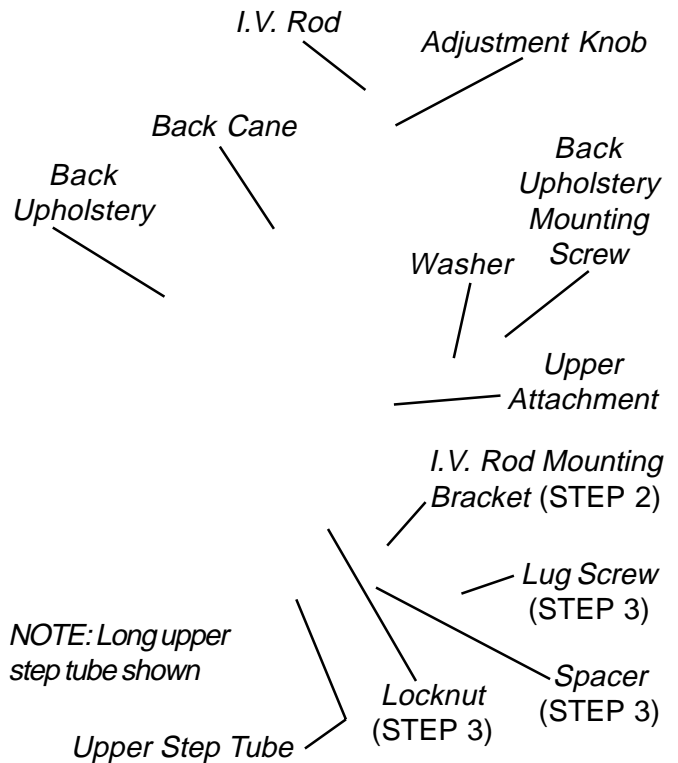

FIGURE 2 - INSTALLING THE TELESCOPING I.V. ROD ON TRANSPORT WHEELCHAIRS ONLY

OPTIONS

**Repositioning The Upper Attachment
(FIGURE 3)**

1. With the Telescoping I.V. rod in the lowest position, align the hole of the outer tube with the phillips screw of the inner tube. Remove phillips screw and set aside.
2. Remove the inner tube from the outer tube.

NOTE: Take note of the position and orientation of the height adjustment assembly before removing. The height adjustment assembly must be positioned to face away from the wheelchair when installed.

3. Firmly grasp the height adjustment assembly and Pull to remove from the outer tube.
4. Slide the upper attachment UP off of the outer tube.
5. Rotate the upper attachment 180° and reinstall onto the outer tube.
6. Reverse STEPS 1-4 to reassemble the telescoping I.V. rod.

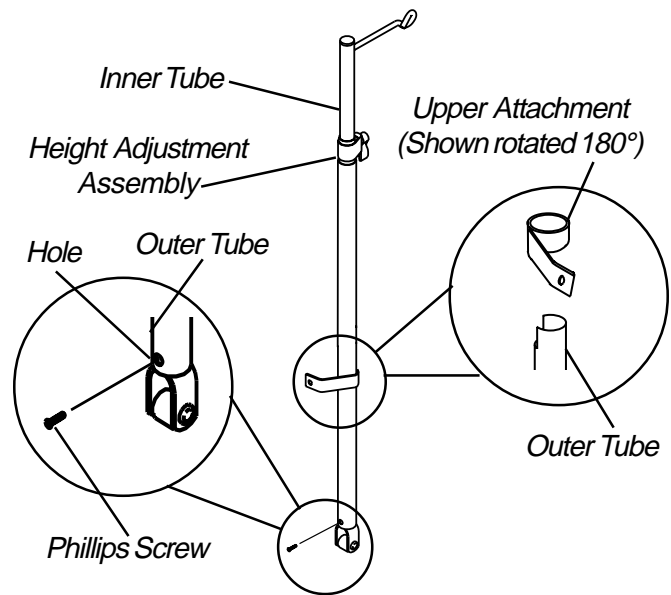

FIGURE 3- REPOSITIONING THE UPPER MOUNTING BRACKET

LIMITED WARRANTY

PLEASE NOTE: THE WARRANTY BELOW HAS BEEN DRAFTED TO COMPLY WITH FEDERAL LAW APPLICABLE TO PRODUCTS MANUFACTURED AFTER JULY 4, 1975.

This warranty is extended only to the original purchaser/user of our products.

This warranty gives you specific legal rights and you may also have other legal rights which vary from state to state.

With regard to the original purchaser/user only, Invacare warrants side frames and crossbraces to be free from defects in materials and workmanship for a period of:

Tracer Transport, Invacare MG	3 Years
Tracer EX, Tracer IV	5 Years

from date of purchase. Upholstered materials (seat, back and armrests [of the arm assembly]) are warranted to be free of defects in material and workmanship for a period of fifteen (15) months. All remaining components for one (1) year from date of purchase except tires/wheels. If within such warranty period any such product shall be proven to be defective, such product shall be repaired or replaced, at Invacare's option. This warranty does not include any labor or shipping charges incurred in replacement part installation or repair of any such product. Invacare's sole obligation and your exclusive remedy under this warranty shall be limited to such repair and/or replacement.

For warranty service, please contact the dealer from whom you purchased your Invacare product. In the event you do not receive satisfactory warranty service, please write directly to Invacare at the address at the bottom of the back cover. Provide dealer's name, address, the product model number, date of purchase, indicate nature of the defect and, if the product is serialized, indicate the serial number. Do not return products to our factory without our prior consent.

LIMITATIONS AND EXCLUSIONS: THE FOREGOING WARRANTY SHALL NOT APPLY TO SERIAL NUMBERED PRODUCTS IF THE SERIAL NUMBER HAS BEEN REMOVED OR DEFACED, PRODUCTS SUBJECTED TO NEGLIGENCE, ACCIDENT, IMPROPER OPERATION, MAINTENANCE OR STORAGE, PRODUCTS MODIFIED WITHOUT INVACARE'S EXPRESS WRITTEN CONSENT INCLUDING, BUT NOT LIMITED TO, MODIFICATION THROUGH THE USE OF UNAUTHORIZED PARTS OR ATTACHMENTS; PRODUCTS DAMAGED BY REASON OF REPAIRS MADE TO ANY COMPONENT WITHOUT THE SPECIFIC CONSENT OF INVACARE, OR TO A PRODUCT DAMAGED BY CIRCUMSTANCES BEYOND INVACARE'S CONTROL, AND SUCH EVALUATION WILL BE SOLELY DETERMINED BY INVACARE. THE WARRANTY SHALL NOT APPLY TO PROBLEMS ARISING FROM NORMAL WEAR OR FAILURE TO ADHERE TO THESE INSTRUCTIONS.

THE FOREGOING WARRANTY IS EXCLUSIVE AND IN LIEU OF ALL OTHER EXPRESS WARRANTIES. IMPLIED WARRANTIES, IF ANY, INCLUDING THE IMPLIED WARRANTIES OF MERCHANTABILITY AND FITNESS FOR A PARTICULAR PURPOSE, SHALL NOT EXTEND BEYOND THE DURATION OF THE EXPRESS WARRANTY PROVIDED HEREIN AND THE REMEDY FOR VIOLATIONS OF ANY IMPLIED WARRANTY SHALL BE LIMITED TO REPAIR OR REPLACEMENT OF THE DEFECTIVE PRODUCT PURSUANT TO THE TERMS CONTAINED HEREIN. INVACARE SHALL NOT BE LIABLE FOR ANY CONSEQUENTIAL OR INCIDENTAL DAMAGES WHATSOEVER.

THIS WARRANTY SHALL BE EXTENDED TO COMPLY WITH STATE/PROVINCIAL LAWS AND REQUIREMENTS.



Invacare Corporation www.invacare.com

U S A
One Invacare Way
Elyria, Ohio USA
44036-2125
800-333-6900

Invacare is a registered trademark of Invacare Corporation.
©1999 Invacare Corporation

Form No. 96-147 Part No. 1063854 Rev G (1) 3/01

Free Manuals Download Website

<http://myh66.com>

<http://usermanuals.us>

<http://www.somanuals.com>

<http://www.4manuals.cc>

<http://www.manual-lib.com>

<http://www.404manual.com>

<http://www.luxmanual.com>

<http://aubethermostatmanual.com>

Golf course search by state

<http://golfingnear.com>

Email search by domain

<http://emailbydomain.com>

Auto manuals search

<http://auto.somanuals.com>

TV manuals search

<http://tv.somanuals.com>