

OWNER'S MANUAL

TRX POWER-POSITIONING SYSTEMS





POWER-POSITIONING SYSTEMS

Important Information

(Please complete this information for your records and for reference during any warranty claims.)

**Motion Concepts
Serial Number:**

(Serial Number is located on the underside of the TRx seat frame)

MC#

Dealer: _____

Address: _____

Phone #: _____

Purchase Date: _____

Power Base (Model): _____





POWER-POSITIONING SYSTEMS

Congratulations on your decision to purchase a Motion Concepts TRx system. Our goal at Motion Concepts is to provide you with the best possible power positioning system. Our close work with many health care professionals has given us an understanding of the challenges that you may confront, and has enabled us to design systems that will help to meet your individual positioning needs. We are confident that you will be delighted with your new positioning system and as you grow or your needs change, your new TRx system will be able to grow and change with you.

If you have any questions or comments, please contact us by calling Motion Concepts USA toll free at 1-888-433-6818 or Motion Concepts Canada at 1-866-748-7943. The more we are able to understand your needs, the better we will be able to meet them.

Important

This owner's manual applies specifically to your TRx Power Positioning System. It is important that you read and understand its contents. It is also very important that you read and understand the owner's manual provided with your power base.

Safety Symbols:

Using your TRx Power Positioning System safely depends upon your diligence in following the warnings, cautions and information provided in this Owner's Manual. Setting up and operating the system safely also depends on your own good judgement and common sense, as well as that of your provider, caregiver and/or health professional.

The symbols below are used throughout this manual to identify warnings, cautions and important notes. It is very important for you to read and understand them completely.

 **CAUTION!** Failure to heed the cautions in this Owner's Manual may result in damage to your TRx Power Positioning System.

 **WARNING!** Failure to heed the warnings in this owner's manual may result in personal injury.

 **Important!** Important information to remember when operating your TRx system

Table of Contents



---	Safety Symbols	2
1.0	Introduction	4
2.0	Important Information about your TRx System	5
	Stability	5
	Batteries	6
	Weight Capacity	6
	Hardware	7
3.0	Safety Precautions	8
4.0	Motor Vehicle Transportation	8
5.0	Power Positioning Functions	9
6.0	TRx Switches	10
	Normal Mode vs. Auto-Reversing Mode	10
	TRx Switch Types	11
7.0	Using the Power Base Joysticks:	12
	7.1 Quickie Q-tronix Joystick	12
	7.2 Pride Remote Plus Joystick	13
	7.3 Invacare MKIV A Joystick	14
	7.4 Invacare MKV- DPJ Joystick	15
	7.5 Invacare MKV- MPJ Joystick	16
8.0	Safety Lockout and Limit Switches	17
9.0	General Maintenance & Safety	18
	Maintenance Schedule	18
	Safety Inspection Checklist	18
	Lubrication	19
	Battery Charging	19
	Battery Testing	20
10.0	Troubleshooting Guide	21
11.0	Electro-Magnetic Interference	22
12.0	Disclaimer and Warranty Information	24

1.0 Introduction



About Concepts

Motion Concepts is a Toronto based company that designs and manufactures the TRx line of Power Positioning Systems. These systems were developed to provide effective positioning and pressure reduction for a wide range of disabilities. The modular design incorporates Center of Gravity Tilt, Power Recline, Extended Shear Reduction, Power Elevating Seats, Power Legrests, Auxiliary Vent and Power Systems. These systems have been designed to easily install on most types of power bases.

Our Mission at Concepts

At Motion Concepts we recognize the importance of independence and function. We are a dynamic team dedicated to service, manufacturing, and design excellence. We understand unique seating and positioning needs and continuously strive to enhance our clients' quality of life.

Contact Us

Do you have a question, comment, or suggestion? Please send us an e-mail or write to us. Whether it pertains to information contained in this Owners Manual or if it relates to the safety and reliability of your TRx Power Positioning System, we want your feedback!

Visit our website at www.motionconcepts.com and stay in tune with what's new at Motion Concepts.



Attn: Customer Service
84 Citation Drive
Concord, Ontario
Canada, L4K 3C1



Attn: Customer Service
700 Ensminger Rd. Suite 112
Tonowanda, New York
USA, 14150

info@motionconcepts.com
techsupport@motionconcepts.com

2.0 Important Information about your TRx System



i Important: **Do not ignore unanswered questions. You have the right to understand the product and all aspects of its operation. If necessary, please contact Motion Concepts for information regarding any questions or concerns expressed.**

The most important link in the delivery chain is you, the end user. You must be satisfied with the product in terms of function, safety and aesthetics. No sale is complete until you have received thorough training in all aspects of the care and use of the system.

Motion Concepts Power Positioning Systems are designed to accommodate a wide range of user needs. Only the dealer and the health care professional can ensure that the system meets your individual requirements. It is the dealer's responsibility to ensure that the wheelchair and the power positioning system are set up properly and safely for your specific needs.

STABILITY

By changing your seating position (tilting, reclining, or elevating), you are changing the stability characteristics of the wheelchair. It is very important that the system is set up so that it is stable in all seating positions. When evaluating stability, remember the following:

Most TRx systems can be mounted onto the powerbase in various forward and aft positions. Make certain that the position selected provides you with maximum stability over the full range of seating positions.

Consider all personal gear and accessories (backpacks, vent systems, extra batteries, etc..) that will be carried on the wheelchair. For example, a loaded backpack, attached to the back of the seating system, can significantly reduce the rearward stability of your wheelchair.

Consider the backrest being used. For example, a recessed back can shift your center of gravity back and significantly reduce the rearward stability of the wheelchair. Conversely, a thick back cushion will shift you forward and reduce the wheelchairs forward stability.

If using a back other than Motion Concepts, check with manufacturer to ensure it is suitable for power positioning system applications.

Consider the seat cushion being used. A thick seat cushion will raise your center of gravity and reduce the wheelchairs stability in all directions.

All TRx systems are equipped with drive lockouts. Make sure this is set so as not to compromise your stability while driving.

All power-bases have programmable controllers which allow adjustment of the maximum acceleration and deceleration of the wheelchair. Make sure that these are set to an appropriate level for the system and for you, the user.

Ensure all medical conditions are considered when setting up your wheelchair. Involuntary muscle movement such as spasms may affect the stability of the wheelchair, especially when the seating system is in a tilted or reclined position.

When a system is fully tilted or reclined, the front wheels of the powerbase should **never** come off the ground. If this occurs, please contact the Motion Concepts Technical Service Department immediately to resolve the issue.

2.0 Important Information about your TRx System



BATTERIES

⚠ WARNING! For detailed information on the charging, handling and care of your powerbase batteries, please be certain to read and carefully follow the instructions provided by the powerbase manufacturer and the battery charger manufacturer.

i Important Information on Battery Charging:

DO NOT use the **CHARGE LEVEL INDICATOR** on a **JOYSTICK DISPLAY** to determine the existing battery charge. The joystick display indicates **SURFACE VOLTAGE** only, and may not be the true charge. *(This can be likened to charging a cell phone; if placed on its charger for a brief time, a cell phone display will often indicate that the batteries are fully charged, however the cell phone quickly goes dead once it is used).*

Heavily depleted batteries require more time to recharge. Insufficient charge time may result in the supply of **LOW VOLTAGE BATTERY OUTPUT** to the electronics of the power positioning system. Low voltage output can produce **LONGER DUTY-CYCLES** and **OVERHEATING**, which will **REDUCE THE LIFE-CYCLE** of these electronics.

RECOMMENDED CHARGING PROCEDURES:

Normal Charging: Allow eight **(8) HOURS** for normal charging. *(Note: to prolong the life of a battery frequent charging is recommended, rather than only charging when necessary).*

Heavily Depleted Batteries: Severely discharged batteries may require in excess of sixteen **(16) HOURS** to be properly charged and equalized. *(Note: be certain to understand the charge status indicators on the battery charger- refer to the charger manual).*

Note: Smaller **ON-BOARD CHARGERS** are **NOT SUFFICIENT** to recharge rehab-style power products.

Batteries that require more frequent charging or take longer to charge than normal, may need to be replaced.

WEIGHT CAPACITIES

⚠ WARNING! *The total user weight should never exceed the wheelchair weight capacity or the power positioning system (PPS) weight capacity.*

Several factors must be considered when determining the Total User Weight and the Wheelchair Weight Capacity. To obtain the weight capacity data from the base manufacturer, please refer to your Powerbase Owners Manual. Please refer to the Weight Capacity Calculator outlined below in order to calculate the total user weight and the wheelchair weight capacity.

i) Power Positioning System (PPS) Weight

The weight of a specific power positioning system can be obtained from Motion Concepts by contacting our Customer Service department*. Insert the PPS Weight into the **Weight Capacity Calculator** (p.7) to verify that the Total User Weight does not exceed the calculated Wheelchair Weight Capacity.

***Note:** If a suitable weight scale is available at the Dealer facility, the PPS Weight can be readily determined by simply weighing the TRx Seating System prior to installation.

ii) Power Positioning System (PPS) Weight Capacity

The weight capacity of the power positioning system can be obtained from Motion Concepts by contacting our Customer Service department. Insert the specified PPS Weight Capacity into the **Weight Capacity Calculator** (p.7) in order to verify that the Total User Weight does not exceed the PPS Weight Capacity.

2.0 Important Information about your TRx System



iii) Weight Capacity Calculator



Calculating Wheelchair Weight Capacity:

Weight capacity of base manufacturer's wheelchair (see <i>Powerbase Owners Manual</i>)		_____
Weight of the original wheelchair seat that is being replaced (if the original wheelchair seat is being re-installed, enter zero)	+	_____
Weight of the TRx Power Positioning System (refer to p.6, i. PPS Weight)	-	_____
Weight of auxiliary equipment (cushions, headrest, vent, vent battery, etc)	-	_____
Wheelchair Weight Capacity	=	_____ A

PPS Weight Capacity: (refer to p.6, ii. PPS Weight Capacity)	=	_____ B
--	---	----------------

Calculating User Weight:

Weight of user (incl. clothing, footwear, jacket, etc)		_____
Maximum Weight of personal gear (knapsack and contents, books, etc)	+	_____
Total User Weight	=	_____ C

*** (**C** must be less than **A** and **C** must be less than **B**)***

i Important: If you have any concerns or questions regarding weight capacities, or if the total **User Weight** is determined to be greater than the **Wheelchair** and/or **PPS Weight Capacity**, please contact our Technical Service Department immediately

HARDWARE

⚠ WARNING! All hardware used by Motion Concepts in the manufacture of our TRx Power Positioning Systems, as well as the hardware supplied to complete the installation of our seating systems, is high strength. **Do not substitute hardware. Use only the hardware supplied with the seating system.**

Should you require any replacement hardware for your TRx seating system, please contact our Customer Service Department for assistance.

3.0 Safety Precautions



i Important!- **Motion Concepts disclaims all responsibility for any personal injury or damage to property that occurs as a result of improper or unsafe use of the TRx system or the wheelchair on which the system is installed.**



WARNING! *The following guidelines should be adhered to while operating your TRx power positioning system to ensure safe operation:*

- ◆ Never transfer in or out of your wheelchair with the power on.
- ◆ Always check your surroundings before operating your TRx system. Make sure that the way is clear of obstructions through the full ranges of travel of the system before operating any function. Do not operate the system while it is underneath a table, desk, or other obstruction.
- ◆ Never operate your TRx system while driving your wheelchair.
- ◆ Never operate your TRx system while on an incline.
- ◆ Never drive your wheelchair with the drive lockout system disabled or set beyond the maximum 20 degrees.
- ◆ Never allow your TRx system to be used as a tie-down point in a vehicle.
- ◆ Never allow your wheelchair to be lifted by any part of the TRx System.
- ◆ If you have a system with anti-tipper lockouts, be aware of when these lockouts engage. Make sure to drive very carefully when driving your wheelchair with the anti-tipper lockouts engaged. For more information refer to **Section 8.0- Safety Lockout and Limit Switches** in this manual.
- ◆ When tilted or reclined back, prevent your arms from extending back beyond the backrest. This could shift your center of gravity enough to cause the wheelchair to become unstable. *(Read and follow the warnings/specifications in your powerbase manual on the subject of leaning).*

4.0 Motor Vehicle Transportation



WARNING! **Currently there are no standards approved for tie-down systems in a moving vehicle of any type to transport a person while seated in a power wheelchair. Do not sit in your wheelchair while it is in a moving vehicle. Although your chair may be equipped with a positioning belt, this belt is not designed to provide proper restraint during motor vehicle transport. Anyone travelling in a motor vehicle should be properly secured in the motor vehicle seat with safety belts securely fastened.**

5.0 Power Positioning Functions



Tilt

The tilt function causes the whole seat, including the back and armrests, to rotate back around a fixed pivot.

CG (Centre of Gravity) Tilt

The CG tilt function compensates for weight shift by sliding the pivot axis and entire seat assembly forward as the seat tilts back.

Recline

The recline function causes the position of your back to change by changing the angle of the backrest with respect to the seat pan.

Precline

The precline function is similar to the recline function, but depending on the system may allow up to 30° of forward recline (creating a lean-forward position). The range of recline is decreased approximately by the number of degrees of precline.

Anterior Tilt

The anterior tilt function causes the whole seat, including the back and armrests, to tilt forward around a front pivot. The degree of anterior tilt available, up to a maximum tilt of 30°, will depend on the system. This function aids in forward standing transfers.

Extended Shear Reduction (ESR)

ESR works in conjunction with recline to reduce the shear movement between you and the backrest. This is accomplished using a linkage that slides the backrest down on the backposts as the back reclines.

Power Sliding Back (PSB)

The switch operated PSB allows the back height to be adjusted to improve positioning and shift body weight. The PSB may also be synchronized to operate in conjunction with the recline function.

Power Elevating Seat (PES)

This functions allows you to elevate your entire seating system by up to 8 inches.

Power Elevating Legrests

There are 3 configurations for power legrests:

- i) ***Combined:*** the legrest actuators are programmed to elevate in unison keeping your right and left legs at the same height.
- ii) ***Synchronized:*** the legrests actuators are programmed to elevate in conjunction with the power recline function (***Note:*** *legrests can also be synchronized with power tilt if specified*). The legrests elevate automatically as the seating system reclines (*or tilts*).
- iii) ***Independent:*** the legrest actuators are programmed to elevate separately to allow you to position your right and left legs at different heights, independent from each other and the back position.

Pushrod Legrests (Mechanical)

The pushrod legrests are synchronized with the power recline and operate via a mechanical linkage. A pushrod elevates the legrests automatically as the seating system reclines. No additional actuators are required.

6.0 TRx Switches



Normal Mode vs. Auto-Reversing Mode

TRx Push Buttons and Toggles can be set up to operate in “Normal” or “Auto-Reversing” mode.

- i) Normal Mode: two *switches* are required for each function, one for each direction.
- ii) Auto-Reversing Mode: only one *switch* is required for each function. In this mode, pressing the switch once will activate the function; releasing the switch, waiting for two seconds and then pressing it again, will cause the reverse direction of this function to occur.

Tables A. and B. below show a comparison of Normal Mode vs. Auto-Reversing Mode when using a toggle and/or a push button to control the tilt function of a power positioning system.





<i>Table A. - Using a <u>single toggle</u> to control the tilt function:</i>	
Normal Mode	Pulling the toggle back will cause the seat to tilt back. Pushing the toggle forward will cause the seat to tilt forward.
Auto-Reversing Mode	Pushing the toggle forward will cause the seat to tilt back. Releasing the toggle to its rest position, waiting for two seconds, and pushing it forward again, will cause the seat to tilt forward. <i>(This set-up allows the rearward (pulled back) toggle direction to be used for a separate power positioning function (e.g. Recline))</i>

<i>Table B. - Using a <u>dual push button</u> to control the tilt function:</i>	
Normal Mode	Pushing the first button will cause the seat to tilt back. Pushing the second button will cause the seat to tilt forward.
Auto-Reversing Mode	Pushing the first button will cause the seat to tilt back. Releasing the button (rest position), waiting for two seconds, and pushing the same button again, will cause the seat to tilt forward. <i>(This set-up allows the second push button to be used for a separate power positioning function (e.g. Recline))</i>

6.0 TRx Switches

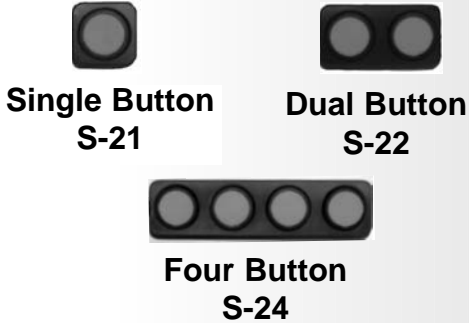
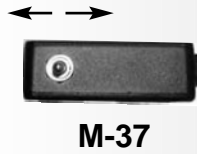
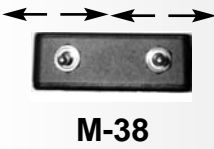

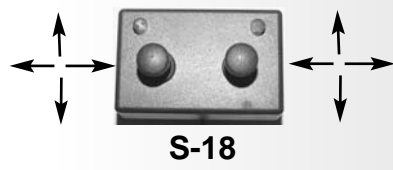
TRx Switch Types

<p>Push Button Switches</p> <p>The push button switches come in singles, and sets of two and four. To activate the function simply hold the button down. The motion will stop when the button is released. Two buttons are required for each function in "Normal" mode, and one button is required for each function in "Auto-Reversing" mode.</p>	 <p>Single Button S-21 Dual Button S-22</p> <p>Four Button S-24</p>
<p>Single Toggle</p> <p>This type of switch is capable of operating one function in "Normal" mode and two functions in "Auto-Reversing" mode.</p>	 <p>M-37</p>
<p>Dual Toggle</p> <p>This type of switch is capable of operating two functions in "Normal" mode and four functions in "Auto-Reversing" mode.</p>	 <p>M-38</p>
<p>Four-Way Toggle</p> <p>This type of switch is capable of operating two functions in "Normal" and four functions in "Auto-Reversing" mode.</p>	 <p>M-26</p>
<p>Eight-Way Toggle</p> <p>This type of switch is capable of operating four functions in "Normal" and eight functions in "Auto-Reversing" mode.</p>	 <p>S-18</p>
<p>Heavy Duty Toggle</p> <p>This type of switch is capable of operating one function in "Normal" mode.</p>	 <p>S-37</p>

7.0 Using the Power Base Joysticks



7.1 Using the Quickie Q-TRONIX Remote Joystick

The remote joystick connects to the Q-Tronix Controller, which in turn controls the performance of the power base. By pressing *down* and releasing the **on/off mode select toggle** switch, the controller is placed in the **standard drive selection** mode. To place the controller in the **power positioning mode**, the on/off mode select toggle switch must be pulled *up* twice. The power positioning options are selected by using the left and right directions on the joystick. The power positioning function that is selected will be highlighted on the **actuator lights** (see chart). To operate the selected power positioning function, the forward and reverse directions on the joystick are used. To return to the **standard drive selection** mode, the on/off mode select toggle switch must be pulled up once again.

Note: Please refer to the Quickie Owners Manual for complete joystick set-up and operating instructions.

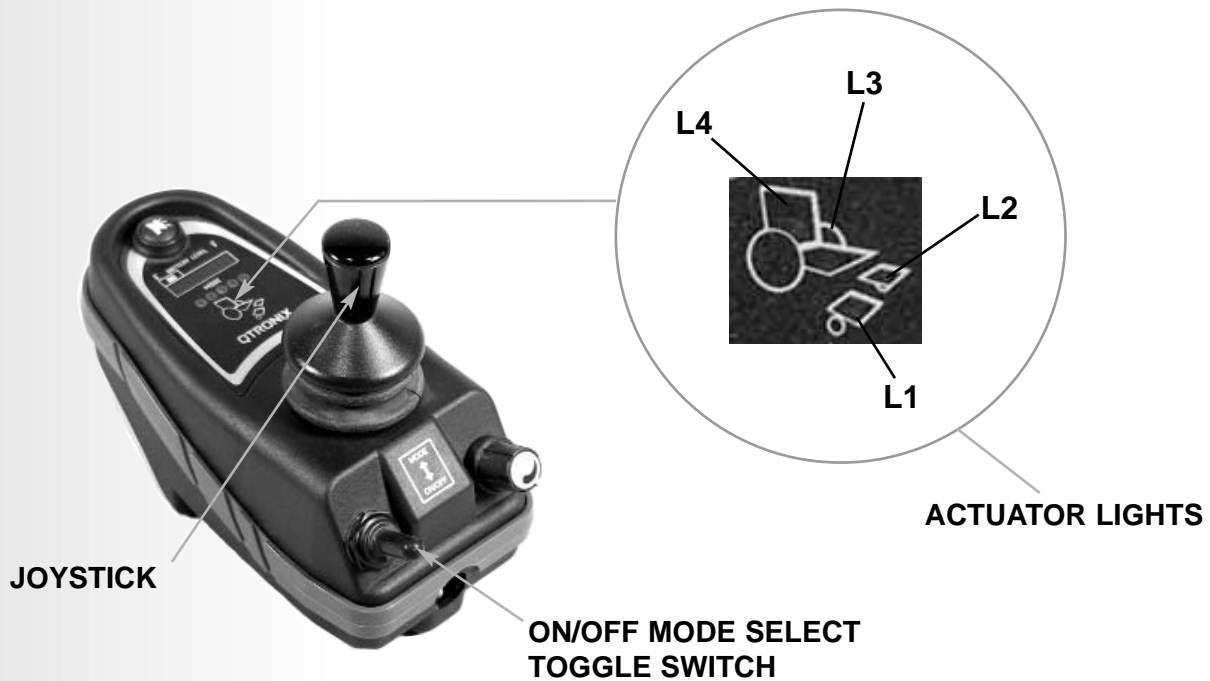

Function	Actuator Light			
	L1	L2	L3	L4
*Tilt/Recline			+	+
Right Legrest	+			
Left Legrest		+		
Both Legrests	+	+		
Elevating Seat			+	

*Push forward on joystick to tilt and pull back on the joystick to recline (i.e. operates in "auto-reversing mode")

7.0 Using the Power Base Joysticks



7.2 Using the (Pride) PG Remote Plus Joystick

The Remote Plus system operates via a joystick that is connected to a controller box on the power base. The controller contains the primary electronics that operate the power base. By pressing once on the **on/off key**, the controller is placed in the **standard drive selection mode**. To place the controller in **power positioning mode**, the **mode key** must be pressed down twice. The power positioning mode can now be selected by using the left and right directions on the joystick. The power positioning function that is selected will be highlighted on the **LED Display** (see chart). To operate the selected power positioning function, the forward and reverse directions on the joystick are used. To return to standard drive selection mode, the mode selection key must be pressed once more.

Note: Please refer to the Pride Owners Manual for complete joystick set-up and operating instructions.

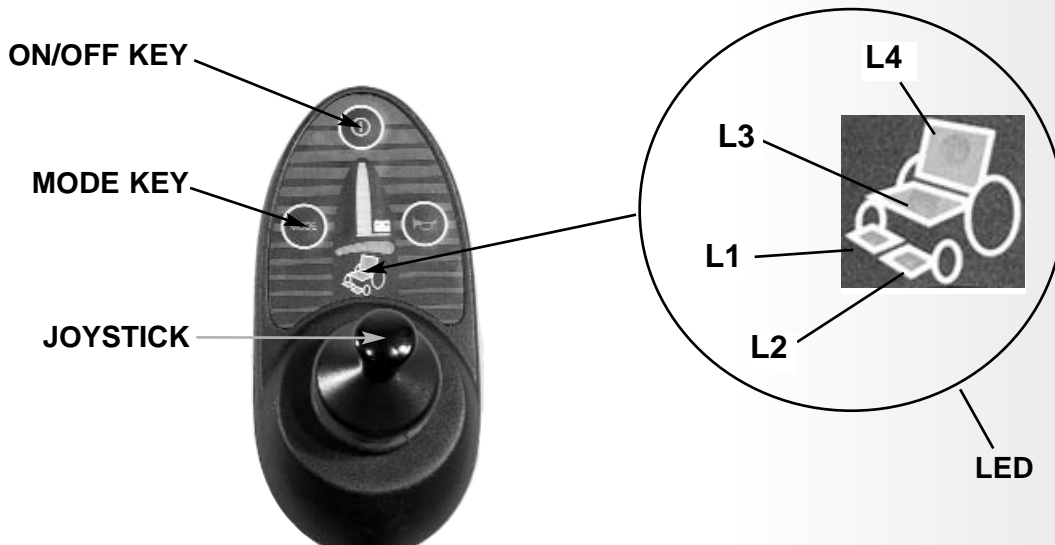

Function	LED			
	L1	L2	L3	L4
*Tilt/Recline			+	+
Right Legrest	+			
Left Legrest		+		
Both Legrests	+	+		
Elevating Seat			+	

*Push forward on joystick to tilt and pull back on the joystick to recline (i.e. operates in "auto-reversing mode")

7.0 Using the Power Base Joysticks



7.3 Using the Invacare MKIV A Joystick

By pulling up and releasing the **toggle switch**, the controller will be placed in the **standard drive selection mode**. The mode indicator light will remain on in drive selection mode. To place the controller in the **power positioning mode** (ECU/Recline), the controller must sit inactive until the mode indicator light begins to flash, then the joystick must be tapped to the left. (*For complete instructions on the set-up and operation of the power positioning system through the joystick, please refer to the Invacare Owners Manual*). The power positioning functions may be assigned to one or more drive modes depending on the system set-up. To select the required drive mode, the toggle switch must be pulled up again and released. This operation will be repeated until the required drive mode light appears. To operate the power positioning functions*, the joystick can be moved in the forward, reverse, left and right directions. The mode indicator light will remain OFF while in the power positioning mode. To return the controller to **standard drive selection mode**, the controller must remain inactive until the mode indicator light begins to flash, then the joystick may be moved once in any direction.

***Note:** *The power positioning functions may be assigned to the joystick depending on the type of seating system and the users preferred set-up (eg. forward= tilt, reverse= recline, etc...) An Invacare Programmer is required in order to program/assign the specific motor functions to the MKIV-A Joystick. Please refer to the Invacare Manual for complete programming instructions.*



7.0 Using the Power Base Joysticks



7.4 Using the Invacare MKV- DPJ Joystick

The MK5-DPJ joystick has two programmable **drive selection modes**: Drive 1 and Drive 2. To select **Drive 1** mode, the **toggle switch** must be placed in the UP position. To select **Drive 2** mode, the toggle switch is placed in the MIDDLE position. The mode switch **LED indicator light** will be OFF when the wheelchair is placed in either drive mode. To put the controller in the **power positioning mode*** (ECU/Recline), the **mode switch** must be pressed. The LED indicator light will be turned ON while in the power positioning mode. To operate the power positioning functions, the joystick can be moved in the forward, reverse, left and right directions. (*Note*: power positioning functions may be assigned to the joystick directions depending on the seating system). To return to the drive selection mode, the mode switch must be pressed again until the LED indicator light is OFF.

***Please Note:** The DPJ Joystick is a basic model joystick and has limited programming capabilities for power positioning. Please refer to the Invacare Manual for complete programming instructions.



7.0 Using the Power Base Joysticks



7.5 Using the Invacare MKV- MPJ Joystick

The MK5-MPJ joystick has **four** independent programmable **drive selection modes**: Drive 1, Drive 2, Drive 3, & Drive 4. The individual Drive modes can be selected by lifting and releasing the **toggle switch**. The selected Drive mode appears in the **LCD display** on the joystick. Each time the toggle switch is lifted and released it will cycle through to the next Drive mode. (i.e.; To select Drive 1 mode, the toggle switch is lifted up once and released. To select Drive 2, the toggle switch is lifted again and released, to select Drive 3... etc...) The controller will return back to Drive 1 after Drive 4. To operate the **power positioning system** (ECU/Recline) through the joystick, a separate **emergency stop (reset) switch** is typically installed. To access ECU1, tap the joystick to the left 2 times (left/left); if ECU2 is required tap the joystick to the left 2 times and hold (left/left hold). (*For complete instructions on the set-up and operation of the power positioning system through the joystick, please refer to the Invacare Owners Manual*). To operate the power positioning functions, the joystick can be moved in the forward, reverse, left and right directions. The functions may be programmed* into the joystick depending on the type of seating system and the users preferred set-up (eg. forward= tilt, reverse= recline, etc...) The emergency reset switch must be opened in order to return to the drive selection mode.

***Please Note:** An Invacare Programmer is required in order to program/assign the specific motor functions to the joystick. Please refer to the Invacare Manual for complete programming instructions.



8.0 Safety Lockout and Limit Switches



⚠ WARNING! The angle at which the limit switches are set is critical to the safe operation of the power positioning system. Motion Concepts will not be liable for any injuries or damage sustained when adjustments are made beyond the factory recommended range. These switches should only be adjusted and set by a trained Technician.

i Important: *Please refer to the Motion Concepts General TRx Set-up Manual for detailed instructions on setting and adjusting Limit Switches*

Drive Lockout (DLO) Limit Switch

All TRx systems with *tilt and/or recline functions* are equipped with a drive lockout limit switch. This switch prevents the drive motors from operating if the back is positioned beyond a pre-determined angle. The **recommended drive lockout angle is 15° to 20° from the vertical**. The limit switch should be set to the angle that best meets the overall stability and individual needs of the user, but should not exceed the maximum 20° angle.

All TRx systems with *power elevating seats* are also equipped with a drive lockout limit switch. These systems typically use a microswitch to prevent the drive motors from operating once the seat begins to elevate. The microswitch should engage the Drive Lockout when the seat actuator has been elevated beyond a **recommended 1/2" limit** [measured from the seat's home (lowest) position].

Tilt Limit Switch

All TRx systems, except those using our basic single motor function relay box, can be equipped with a tilt limit switch. The function of this switch is to prevent the back angle from extending beyond a pre-set angle. Ultimately the angle should be set to meet the individual needs of the user. However, the recline angle should **never extend beyond a recommended 5° from the horizontal**. The limit must also be checked to ensure that with any combination of tilt and recline, there is absolutely no possibility of interference between the back of the TRx system (or any accessories located on the back), and the wheelchair base.

⚠ CAUTION! When setting tilt limits remember to consider the size and location of any personal gear that will be carried on the wheelchair, as it could cause interference with tilt or recline motor functions.

Elevating Seat Lockout Switch

All TRx power elevating seat systems, when combined with tilt and/or recline functions, are equipped with an elevating seat lockout switch. This limit switch prevents the PES actuator from elevating or descending when the system is in a tilted or reclined position. The recommended lockout limit should not exceed a maximum of 8° from the seating system's original pre-tilt ("home") position, and it is **recommended to be set between 3° and 8°**.

Anti-Tipper Latch Limit Switch

Certain powerbases come equipped with anti-tip devices that latch in order to ensure stability during tilt, recline or elevating functions. For these powerbases, our TRx systems are engineered to control and engage the anti-tipper latch through the use of a limit switch. The recommended limit switch settings are determined by the type of power positioning system:

- i) **Tilt-Only:** set switch to engage the anti-tippers **when seat angle is at 10°** (regardless of pre-tilt angle).
- ii) **Tilt/Recline & Recline-Only:** set switch to engage the anti-tippers **when the back reclines 10°** (from upright)
- iii) **Power Elevating Seats (PES):** set switch to engage the anti-tippers when seat actuator has **elevated beyond a recommended 1/2" limit**.

In some instances, an anti-tipper latching system is added to the power base as part of the installation in order to ensure the stability of the power positioning system is maintained.

9.0 General Maintenance & Safety



MAINTENANCE SCHEDULE

To ensure the optimal safety and reliability of your power positioning system, please adhere to the maintenance schedule/table below. In addition to the maintenance schedule, please note the following maintenance tasks that should be incorporated into your daily routine.

Daily

- ◆ Check that the buttons or toggles that operate your TRx system function freely
- ◆ Charge batteries (refer to the information provided in this chapter and to your powerbase Owners Manual for details on battery charging & battery care)

To ensure your power positioning system is operating properly and safely, Motion Concepts recommends a complete Dealer inspection be performed on your power positioning system every 6 months.

Please refer to the Powerbase Owners Manual for maintenance information specific to your powerbase

SAFETY INSPECTION CHECKLIST

Item	Initially	Monthly	6 Months	Periodically
Batteries				
load test batteries (individually) - see <i>Battery Testing p.20</i>	X		X	
ensure batteries are clean (free from corrosion/ moisture/ dirt)	X		X	
ensure connections are tight and clean	X		X	
Electrical / Wiring Harnesses				
check for pinches or pulls in wiring (<i>over full range of seating system</i>)	X	X		
inspect for wear & tear damage to wires	X	X		
ensure connections are secure	X	X		
Actuators (where applicable)				
ensure actuator rod ends are secure and pinned properly	X		X	
ensure no interference/ sticking during system operation (<i>over full range of seating system</i>)	X			X
inspect for excessive noise or grinding	X			X
Tightening & Adjustment (hardware)				
ensure that the anti-tipper latch system functions properly (if applicable)	X	X		
mounting hardware (seating system to powerbase)	X			X
ensure all nuts and bolts are secure	X			X
inspect that all pivot points are operating smoothly & freely and secured (do not overtighten)	X			X
Limit Switches				
check all limit switch settings	X	X		
ensure DLO functions correctly	X	X		
Glide Blocks and Track Maintenance				
ensure channel is free from dirt/ dust/ grime	X			X
as needed , lightly lubricate slide channel using a non-lithium/ non-aerosol cleaner (eg. AGS- Sil Glyde Brake Lubricant)				X

9.0 General Maintenance & Safety



LUBRICATION

i Important: To maintain the smooth operation of your TRx Power Positioning System, occasional lubrication of the slide channels and/or the Power Elevating Seat (PES) actuator* is necessary. All Motion Concepts Seating Systems are pre-lubricated at the factory using Sil-Glyde® Brake Lubricant. Testing has proven this lubricant to be extremely effective in our system applications. Motion Concepts strongly discourages the use of any other grease or lubricants. A packet of Sil-Glyde® Brake Lubricant (P/N- TRM0464) is provided with each TRx Seating System (*additional lubricant is available from Motion Concepts*).

i) Slide Channel Lubrication

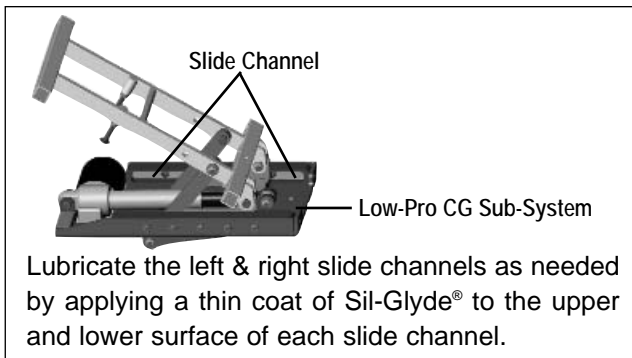

ii) PES Actuator Lubrication

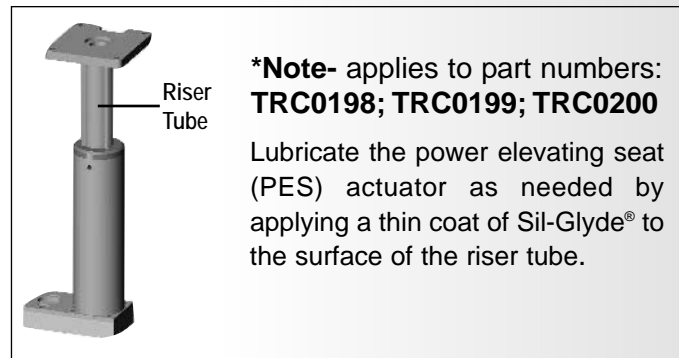

BATTERY CHARGING

! **WARNING!** For detailed information on charging your powerbase batteries, please be certain to read and carefully follow the instructions provided by the powerbase manufacturer and the battery charger manufacturer.

Important Information on Battery Charging:

DO NOT use the **CHARGE LEVEL INDICATOR** on a **JOYSTICK DISPLAY** to determine the existing battery charge. The joystick display indicates **SURFACE VOLTAGE** only, and may not be the true charge. (*This can be likened to charging a cell phone; if placed on its charger for a brief time, a cell phone display will often indicate that the batteries are fully charged, however the cell phone quickly goes dead once it is used*).

Heavily depleted batteries require more time to recharge. Insufficient charge time may result in the supply of **LOW VOLTAGE BATTERY OUTPUT** to the electronics of the power positioning system. Low voltage output can produce **LONGER DUTY-CYCLES** and **OVERHEATING**, which will **REDUCE THE LIFE-CYCLE** of these electronics.

Recommended Charging Procedures:

NORMAL CHARGING:

Allow **8 hours** for normal charging. (*Note: to prolong the life of a battery frequent charging is recommended, rather than only charging when necessary*).

HEAVILY DEPLETED BATTERIES:

Severely discharged batteries may require in excess of **16 hours** to be properly charged and equalized. (*Note: be certain to understand the charge status indicators on the battery charger- refer to the charger manual*).

Note: Smaller **ON-BOARD CHARGERS** are **NOT SUFFICIENT** to recharge rehab-style power products.

Batteries that require more frequent charging or take longer to charge than normal, may need to be replaced.

9.0 General Maintenance & Safety



BATTERY TESTING

i) Battery Case Draw Test

1. Inspect battery for signs of corrosion, moisture and/or dirt that could lead to unnecessary discharge of the battery.
2. Test with Voltmeter by placing one lead on the *Positive (+)* battery terminal
3. Drag the other lead across the battery case (in different locations).
4. Voltmeter should read **0 (zero)** if the battery is not discharging



ii) No Load Voltage Testing

Test to determine the state of charge of the battery. Refer to the illustration below for testing instructions.

! WARNING! Never attempt a voltage measurement with a test lead in the AMP (A) or MILLIAMP (mA) input terminal. You may be injured or cause damage to the voltmeter.

1. Insert test leads in the input terminals shown.
2. Set switch to volts dc.
3. Turn on lights for 1 minute to bleed off surface charge.
4. Turn lights off and touch probes to circuit as shown.
5. Read display. A fully charged battery typically shows about 12.6V.
(See other typical values in table below.)

The no-load voltage indicates the state of charge not the condition of the battery. A weak battery may indicate a full terminal voltage when it is not supplying current to some accessory.

Voltage	% Charge
12.60V	100
12.45V	75
12.30V	50
12.15V	25

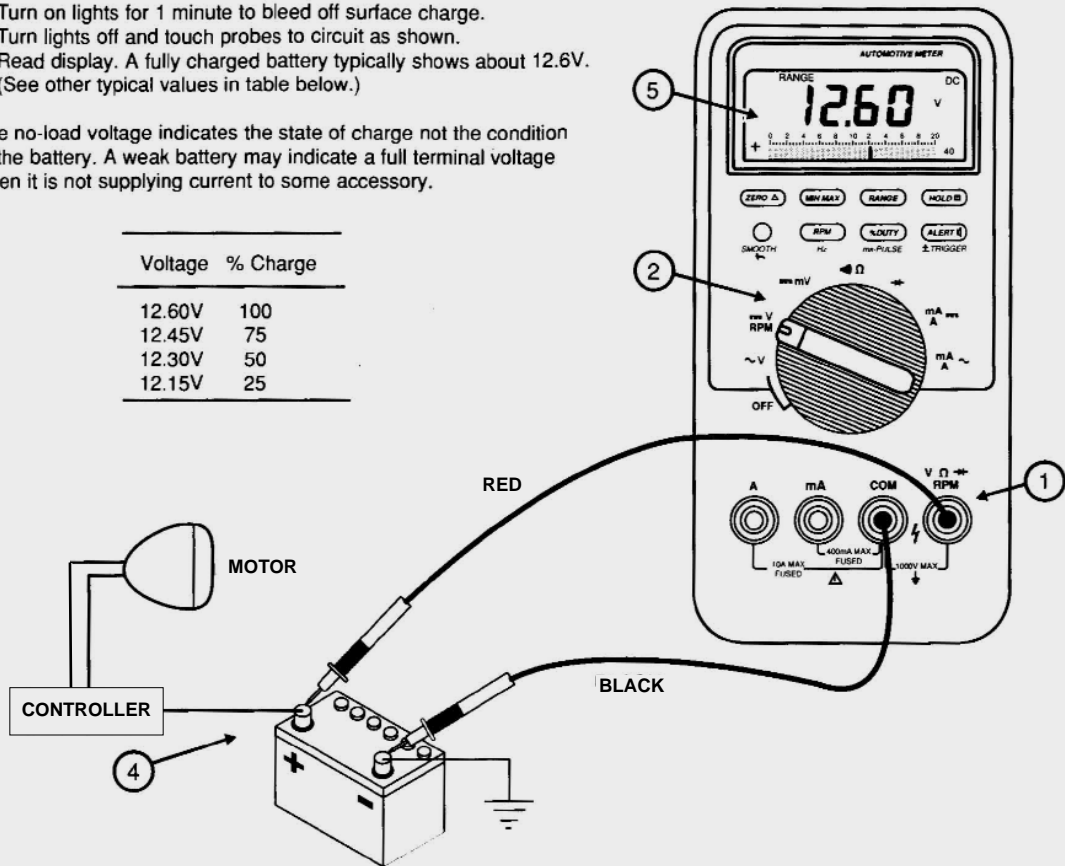

10.0 Troubleshooting Guide



TROUBLESHOOTING GUIDE

Symptom	Probable Cause	Solutions
<i>Wheelchair power is ON, but system does not Drive</i>	System tilted/ elevated beyond the Drive Lockout (DLO) angle Drive Motors not engaged	Return seating system to neutral (home) position. Engage Drive Motors
<i>Seating System is not functioning</i>	Low batteries Loose/ Faulty electrical connection Blown fuse	Check/ Charge/ Replace Batteries Check cable connections/ Check cable ties (too tight/ too loose) Inspect/ Replace fuse.
<i>Intermittent Seating System functions (day to day, during tilt, during recline...)</i>	Loose/ Faulty electrical connection Faulty Power Harness Faulty Mercury Switch Spongy Battery (<i>fluctuating charge</i>)	Check cable connections/ Check cable ties (too tight/ too loose) Check/ Replace Power Harness Check/ Replace mercury switch Check/ Replace Battery
<i>Drive Lockout (DLO) is not functioning</i>	Relay box not programmed correctly Mercury Switch is not set-up properly	Check the relay box configuration guide and verify dip switch/ jumper settings. Adjust Mercury Switch.
<i>DLO red indicator light does not light up</i>	Faulty Mercury Switch Mercury Switch is not set-up properly	Check/ Replace mercury switch Adjust Mercury Switch.
<i>DLO red indicator light is ON, but no lockout</i>	Incorrect switch settings in relay box Incorrect wiring connections	Check dip switch/ jumper settings in relay box (refer to the Configuration Guide) Check connections.
<i>Limit switch not functioning properly</i>	Loose/ faulty electrical connection Faulty limit switch Limit switch is not set-up properly	Check connections. Check/ Replace limit switch Adjust Limit Switch
<i>System only operates in one direction</i>	Faulty limit switch Limit switch is not set-up properly Low Voltage/ Battery not charged	Check/ Replace limit switch Adjust Limit Switch. Test system power cable using Voltmeter/ Charge batteries (Lazarus)
<i>Joystick will not function</i>	Joystick not plugged in Joystick not turned on Blown base fuse	Inspect cable connection Turn on power to the Joystick via the keypad Inspect/ Replace fuse
<i>Tilt/Recline actuator keeps running</i>	Pinched switch harness Stuck switch	Adjust harness/ cable position to prevent pinching Inspect/ Repair / Replace switch
<i>System 'squeaks' during actuator functions</i>	Pivot point(s) sticking Slide channel sticking	1st- oil pivot(s) 2nd- lightly grease pivot(s) (AGS-Sil Glyde) lightly grease channels (eg. AGS-Sil Glyde)

*Note: For further assistance on these or any other issues, contact our Technical Service Department at 888-433-6818.

11.0 Electro-Magnetic Interference



Electromagnetic Interference Warning



WARNING! It is very important that you read this information regarding the possible effects of electromagnetic interference on your TRx power positioning system.

In addition, operation of power positioning systems can create electro-magnetic interference, the effect of which cannot be determined. Please make sure to read the associated warnings in the owner's manual for your power base.

Electromagnetic Interference (EMI) From Radio Wave Sources

Power positioning systems may be susceptible to electromagnetic interference (EMI), which is interfering electromagnetic energy (EM) emitted from sources such as radio stations, TV stations, amateur radio (HAM) transmitters, two way radios and cellular phones. The interference (from radio wave sources) can cause the power positioning system to function by itself, or activate in unintended directions. It can also permanently damage the control system.

The intensity of the interfering EM energy can be measured in volts per meter (V/m). Each power positioning system can resist EMI up to a certain intensity. This is called its "immunity level", the higher the immunity level, the greater the protection. At this time, current technology is capable of achieving at least a 20 V/m immunity level, which would provide useful protection from the more common sources of radiated EMI.

There are a number of sources of relatively intense electromagnetic fields in the everyday environment. Some of these sources are obvious and easy to avoid. Others are not apparent and exposure is unavoidable.

The sources of radiated EMI can be broadly classified into three types:

1. Hand-held portable transceivers (transmitters-receivers with the antenna mounted directly on the transmitting unit) - examples include: cellular telephones, citizen band (CB) radios, "walkie-talkies", security, fire and police transceivers and other personal communication devices. NOTE: Some cellular telephones and similar devices transmit signals while they are "ON", even when they are not being used.
2. Medium range mobile transceivers, such as those used in police cars, fire trucks, ambulances, and taxis. These usually have the antennae mounted on the outside of the vehicle.
3. Long range transmitters and transceivers, such as commercial broadcast transmitters (radio and TV broadcast antenna towers) and amateur (HAM) radios.

Note: Other types of hand held devices, such as cordless phones, laptop computers, AM/FM radios, TV sets, CD players, cassette players, and small appliances such as electric shavers and hair dryers, so far as we know, are not likely to cause EMI problems to your power wheelchair.

11.0 Electro-Magnetic Interference



Electromagnetic Interference Warning continued

Because EM energy rapidly becomes more intense as one moves closer to the transmitting antenna (source) , the EM fields from hand-held radio wave sources (transceivers) are of special concern. It is possible to unintentionally bring high levels of EM energy very close to the control system while using these devices.



WARNING! The warnings listed below are recommended to prevent possible interference with the control system of the power positioning system.

- ◆ Do not turn on personal communications devices, such as cellular phones, or operate hand-held transceivers (transmitters, receivers), such as citizens band (CB) radios, while the powered wheelchair is turned on.
- ◆ Be aware of nearby transmitters, such as radio or TV stations, and try to avoid coming close to them
- ◆ If unintended movement occurs, turn the wheelchair off as soon as it is safe to do so.
- ◆ Be aware that adding accessories or components, or modifying the power positioning system may make it more susceptible to EMI. Note: There is no easy way to evaluate their effect on the overall immunity of the powered wheelchair.
- ◆ Report all incidents of unintended movement of the power positioning system to the manufacturer, and note whether there is a source of EMI nearby.



CAUTION! Modification of any kind to the electronics of the power positioning system as manufactured by Motion Concepts may adversely affect the radio frequency interference immunity (RFI) levels.

12.0 Disclaimer and Warranty Information



DISCLAIMER & WARRANTY INFORMATION

Disclaimer

Motion concepts makes no claims as to the therapeutic effectiveness of the products. Our only claims relate to the ability of the products to provide safe and reliable powered repositioning on the equipment onto which they are installed.

Limited Warranty

All structural components manufactured by Motion Concepts are warranted to be free from defects in materials and workmanship for the lifetime of the original owner. Actuators and electronic components are warranted to be free from defects in material and workmanship for a period of two years. If during the warranty period, any component is determined, at the sole discretion of Motion Concepts, to be defective, such component will be repaired or replaced at the option of Motion Concepts.

The sole obligation of Motion Concepts under this warranty shall be to repair or replace any component or components which are found to be defective. For warranty service, contact the dealer from which the system was purchased. The purchaser of the product is responsible for returning the product to the dealer. Any defective component, once replaced under warranty, shall become the property of Motion Concepts. If further service is required, contact Motion Concepts USA at 1-888-433-6818 or Motion Concepts Canada at 905-695-0134.

Limitations and Exclusions

The foregoing warranty shall apply only to the original purchase and shall not apply to product subjected to neglect, abuse, improper operation, accidental damage or improper storage. The warranty shall not apply to products which have been modified or fitted with improper parts or components without the written consent of Motion Concepts. The warranty shall also not apply to a product which has been damaged as a result of unauthorized repairs and/or by circumstances not under the control of Motion Concepts.

The foregoing is exclusive and in lieu of all other warranties, expressed or implied, including, without limitation, implied warranties of merchantability and fitness for a particular purpose. The warranty shall not be extended beyond the duration of the expressed warranty provided herein. Motion Concepts shall not be liable for any consequential or incidental damages whatsoever.

Some jurisdictions do not allow the exclusions or limitation of incidental or consequential damages, or limitation on the length of an implied warranty. Local laws should be reviewed to determine if the above exclusions and limitations apply.

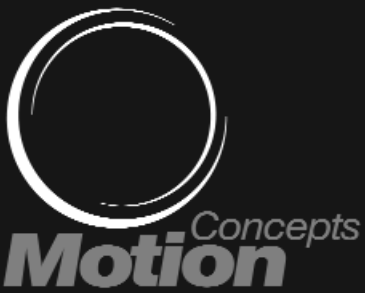

USA

700 Ensminger Rd. Suite 112
Tonawanda, New York 14150
Toll Free Tel: 1.888.433.6818
Toll Free Fax: 1.888.433.6834

Canada

84 Citation Dr.
Concord, Ontario L4K 3C1
Tel: 905.695.0134
Fax: 905.695.0138

www.motionconcepts.com
info@motionconcepts.com

Free Manuals Download Website

<http://myh66.com>

<http://usermanuals.us>

<http://www.somanuals.com>

<http://www.4manuals.cc>

<http://www.manual-lib.com>

<http://www.404manual.com>

<http://www.luxmanual.com>

<http://aubethermostatmanual.com>

Golf course search by state

<http://golfingnear.com>

Email search by domain

<http://emailbydomain.com>

Auto manuals search

<http://auto.somanuals.com>

TV manuals search

<http://tv.somanuals.com>