

Pure-Flo® and Dia-Flo® **Advantage® Actuator** **Maintenance Manual**

This manual provides installation and maintenance instructions for ADVANTAGE® ACTUATOR operated diaphragm valves. If additional information is required, please contact:

ITT Industries
 33 Centerville Road
 Lancaster, PA 17603
 (717) 509-2200
 Attention: Sales Department

CONTENTS:

- 1.0 Advantage® Installation
- 2.0 Advantage® Operation & Adjustment
- 3.0 Advantage® Maintenance
- 4.0 Advantage® Accessories
 - 4.1 Travel (Closing) Stop Adjustment
 - 4.2 Manual Over-Ride (Open) and Adjustable Opening Stop
 - 4.3 Manual Over-Ride (Close) and Adjustable Opening Stop
- 5.0 Switch Pack 2.0
- 6.0 Switch Pack 2.5
- 7.0 Switch Pack 3.0
- 8.0 Positioner

TABLES:

- 1. Fastener Torques
- 2. Actuator Travel and Weights
- 3. Actuator Internal Data
- 4. O-Ring Sizes

FIGURES:

- 1. Actuator Drawings
- 2. Accessories:
 - Travel Stops
 - Manual Over-Ride (Open) with Adjustable Opening Stop
 - Manual Over-Ride (Close) with Adjustable Opening Stop
- 3. Switch Pack 2.0
- 3A. Switch Pack 2.5
- 3B. Switch Pack 3.0
- 4. Positioner
- 5. Valve Diaphragm Identification
- 6. PTFE Diaphragm Detail
- 7. Advantage Assembly & Disassembly Fixture

WARNING

ITT INDUSTRIES VALVES AND VALVE ACTUATORS ARE DESIGNED AND MANUFACTURED USING GOOD WORKMANSHIP AND MATERIALS, AND THEY MEET ALL APPLICABLE INDUSTRY STANDARDS. THESE VALVES ARE AVAILABLE WITH COMPONENTS OF VARIOUS MATERIALS, AND THEY SHOULD BE USED ONLY IN SERVICES RECOMMENDED IN OUR PRODUCT CATALOG OR BY A COMPANY VALVE ENGINEER.

MISAPPLICATION OF THE PRODUCT MAY RESULT IN INJURIES OR PROPERTY DAMAGE. A SELECTION OF VALVE COMPONENTS OF THE PROPER MATERIAL CONSISTENT WITH THE PARTICULAR PERFORMANCE REQUIREMENT, IS IMPORTANT FOR PROPER APPLICATION.

EXAMPLES OF THE MISAPPLICATION OR MISUSE OF ITT INDUSTRIES VALVES INCLUDE USE IN AN APPLICATION IN WHICH THE PRESSURE/TEMPERATURE RATING IS EXCEEDED OR FAILURE TO MAINTAIN VALVES AS RECOMMENDED.

IF VALVE EXHIBITS ANY INDICATION OF LEAKAGE, DO NOT OPERATE. ISOLATE VALVE AND EITHER REPAIR OR REPLACE.

Pure-Flo



ITT Industries

CAUTION - WELD END VALVES

Weld end valves for schedule 10 and heavier pipe require actuator removal prior to welding in line. Schedule 5 and lighter pipe and tubing may be welded with automatic equipment only without removing the actuator. The valve must be in the open position and properly purged with an inert gas. Manual welding requires actuator removal for all tubing gages and pipe schedules.

1 INSTALLATION

- 1.1 Dia-Flo® diaphragm valves may be installed in any orientation. For horizontal piping systems to be drained through the valve, install the valve stem between 0 and 30 degrees above horizontal. **Note: Pure-Flo® valves have either raised hash marks (castings) or small machined dots (forgings) on the valve body to indicate the correct drain angle. Locate these marks at the 12 o'clock position to achieve the optimum drain angle.**
- 1.2 Prior to pressurization (with the valve slightly open), **tighten the bonnet bolts** in a crisscross pattern in accordance with Table 1.
Retightening 24 hours after the system reaches operating temperature and pressure is recommended. If leakage occurs at the body/diaphragm seating area, immediately depressurize system and tighten bonnet bolts as noted above. If leakage continues, diaphragm replacement is required. Follow applicable steps in Section 3.6.1, 3.7.1 or 3.8.1.
- 1.3 The **travel stop** (closing stop), if equipped, is factory set and should not require adjustment at time of installation. However, if adjustment is required, see section 4.1.
- 1.4 Maximum valve operating pressure is 150 PSIG (10.34 bar). This pressure is applicable up to 100 degrees F (38 degrees C), valves at maximum pressure cannot be used at maximum temperatures. **CAUTION:** The actuator size/configuration may limit the actual operating pressure, consult Engineering Catalog for actuator sizing. Consult factory or Engineering Catalog for vacuum operation.
- 1.5 Air line connections should be made with care as damage may occur to the standard plastic actuator covers. Connection size is 1/8" NPT for 1/4" through 2" (DIN 8 - 50) and 1/4" NPT for 3" and 4" (DIN 80 - 100).
- 1.6 **3" and 4" (Series 33 and 47) (DIN 80 and 100) Advantage® actuators must not be lifted by the air fittings.** Prepare an eye bolt with a 0.625" -18 female thread to attach to the adjusting bushing, use a hoist to lift with this attachment. (Series 47 only)
- 1.7 The stainless steel bonnet Advantage® Actuator (1/4"-2") (DIN 8-50) can have the air inlets positioned in any quadrant. The actuator must be removed from the valve body and the actuator diaphragm replacement steps followed. Unthread the bushing, lift and rotate the lower cover to position the air inlet in the desired quadrant. Press down on the cover to insure it sits square on the bonnet and re-assemble the bushing to the proper torque.

Bio-tek:150 in-lb
.50 - 1.0":200 in-lb
1.5/2.0":240 in-lb

2 OPERATION & ADJUSTMENT

- 2.1 The Advantage® actuator is a spring-and diaphragm, or double acting diaphragm, pneumatic actuator. The actuator **model number** is located on the ITT i.d. tag. The model number is a four or five digit number defining the actuator as follows:

AXYYZ
A = Advantage™ Actuator
X = 1 Direct Acting (Spring to Open)
X = 2 Reverse Acting (Spring to Close)
X = 3 Double Acting
YY = Nominal Size. Available sizes
(approximate effective diaphragm area in square inches): #03, 05, 08, 16, 33, 34, 47, 48.
Z = 6 60 PSI Spring Package
Z = 9 90 PSI Spring Package
Z is **only** used for Reverse Acting Units (Spring to Close) sizes 1/4" - 2" (DIN 8 - 50). Note that for the 3" & 4" actuators A233, A247 represent a 60 PSI Spring Package and A248 represents a 80 PSI Spring Package. A234 represents a 90 PSI Package.

- 2.2 **Maximum permitted air supply pressure is 90 psig (6.2 bar, 620 kPa).**

ACTUATOR PRESSURE RATING

The Advantage actuator has a pressure rating of 90 psig. However, the actuator will withstand pressures well in excess of the rated pressure without risk of bursting.

Maintaining operating pressure at or below 90 psig will ensure optimum life of the operating components, such as the actuator diaphragm. However, operation at pressures up to 95 psig, for limited periods of time, will not noticeably affect the life of these components.

- 2.3 For operation and adjustment of actuator **accessories**, see Section 4.0.
- 2.4 Valve and actuator **travel** are shown in Table 2.

3 MAINTENANCE

- 3.1 **Periodic Inspection**
Periodically inspect condition of external valve parts. Replace all parts showing excessive wear or corrosion. Leakage from the lower cover or bonnet weep hole indicates diaphragm rupture. For diaphragm replacement, see Section 3.6.1, 3.7.1, or 3.8.1. On sealed bonnet valves, back off the v-notch vent plug two or three turns. **CAUTION: When the process fluid is hazardous or corrosive, extra precautions should be taken, the user should employ appropriate safety devices and should be prepared to control a leak of the process fluid. Fluid weeping from the plug indicates a diaphragm failure. Replace diaphragm immediately.**
- 3.2 **Pressurized Bonnet**
Air pressure from the lower cover or bonnet weep hole may indicate o-ring failure. Follow applicable replacement instructions in Section 3.6, 3.7 or 3.8.

3.3 Diaphragm-Flange Leakage

If valve diaphragm flange area leaks, depressurize system and open valve slightly, using the wrench opening device (3" & 4" Series 47 only, DIN 80 & 100 only) or a local bleed type regulator. Tighten bonnet bolts as described in Section 1.2. If leakage continues, valve diaphragm replacement is required.

3.4 Lubrication

Standard lubricant is Chevron Poly FM2 (FDA Compliant) for all Pure-Flo® valves (1/4" through 4", DIN 8 - 100) and 1/4" through 2" (DIN 8 - 50) Dia-Flo® valves. Sunoco 991EP is standard for 3" or 4" (DIN 80 or 100) Dia-Flo® valves. The 3" & 4" (DIN 80 & 100) unit requires Never-Seez on the adjusting bushing/spindle threaded joint and on the travel stop nuts/adjusting bushing threaded joint. Actuators should be lubricated in the spindle/o-ring area whenever the actuator is disassembled.

3.5 Advantage® Actuator to Valve Body Mounting Instructions

For double acting (A3YY) and spring-to open (A1YY) actuators, regulate air pressure in upper cover to extend the compressor and assemble valve diaphragm. Correctly position the diaphragm with bolt holes then back the regulator off until the diaphragm just rest against the lower cover. Spring-to close (A2YY) units require air pressure regulated in the lower cover to properly locate the valve diaphragm.

1/4" through 2" (DIN 8 - 50):

Apply a dab of Dow Corning® 111, which has FDA compliance to Title 21 CFR 175.300, to the lead thread of each lower cover insert. (DO NOT OVER-LUBRICATE.) No lubricants are permissible on the diaphragm seal face or body interior/seal area.

Assemble valve body using the torques shown in Table 1.

3.6 Double Acting

(REMOVE ALL LINE PRESSURE)

3.6.1 Valve Diaphragm Replacement

- 3.6.1.1 Disconnect air lines. Remove bonnet bolts, lift actuator assembly from valve body.
- 3.6.1.2 Unscrew diaphragm from compressor by turning counterclockwise.
- 3.6.1.3 For PTFE assemblies only: Replace backing cushion and PTFE diaphragm.
Note: To engage the threads of the diaphragm stud invert the PTFE diaphragm. To invert the diaphragm, press on the center of the diaphragm face with thumbs while holding the edge of the diaphragm with fingers.
- 3.6.1.4 Screw new diaphragm into compressor until hand tight. **DO NOT OVERTIGHTEN.** Then back off until bolt holes in diaphragm and bonnet flange align.

3.6.1.5 Replace actuator assembly on body and tighten bonnet bolts with a wrench, crisscrossing from corner to corner. See Table 1 for recommended torques.

3.6.1.6 Travel stop, if equipped, must be reset at this time to assure proper closure. See Section 4.1.

3.6.2 Actuator Diaphragm Replacement:

(1/4" through 2", DIN 8 - 50)

3.6.2.1 Disconnect air lines. Remove actuator bolts and remove top cover.

3.6.2.2 Remove indicating spindle, diaphragm top plate and actuator diaphragm.

3.6.2.3 Install new diaphragm top hat up, use Blue Loctite #242 on the indicating spindle.

3.6.2.4 Assemble top cover, using care to keep the air fitting in line with the lower cover air fitting.

3.6.2.5 See Table #1 for fastener torques.

3.6.3 Actuator Diaphragm Replacement: (3" & 4" Series 47, DIN 80 & 100)

3.6.3.1 Disconnect air lines. It is best to remove the bonnet bolts, lift actuator assembly from the valve body and move the unit to a bench. Remove clear plastic cap, travel stop nuts, roller-bearing/races, actuator bolts and nuts. Remove top cover.

3.6.3.2 Remove adjusting bushing, spindle nut, diaphragm top plate and actuator diaphragm.

3.6.3.3 Install new diaphragm, top hat up. Reassembly is the reverse of the above, use Blue Loctite #242 on the spindle nut. Be sure to set the adjusting bushing at the correct position 4.06" (10.31 cm) from top of the spindle nut to bottom of adjusting bushing, see Figure 1. See Table 1 for fastener torques.

(3" & 4" Series 33, DIN 80 & 100)

3.6.3.4 Disconnect air lines. It is best to remove the bonnet bolts, lift actuator assembly from the valve body and move the unit to a bench. Remove actuator bolts and remove top cover.

3.6.3.5 Remove extension spindle, both nuts, diaphragm top plate and actuator diaphragm.

3.6.3.6 Install new diaphragm, top hat up. Be sure the diaphragm is positioned so the diaphragm bolt holes line up with

the cover bolt holes with no stretching of the diaphragm. The compressor extends 0.72" from the bonnet face in this relaxed position, reference p. 10 for a view of the compressor position. Re-assembly is the reverse of the above, use Blue Loctite #242 on the spindle nut. See Table 1 for fastener torques.

3.6.4 Spindle O-Ring Replacement (All Sizes)

- 3.6.4.1 Disconnect air lines, remove actuator assembly from valve body and dismantle actuator following instructions above for removing actuator diaphragm.
- 3.6.4.2 Withdraw valve diaphragm, compressor and spindle assembly from the bonnet.
- 3.6.4.3 Remove old o-rings, taking care not to damage machined surfaces. Lubricate new o-rings per Section 3.4 and install in grooves. Reassemble reversing the above instructions. Care must be used on the Bio-Tek to align the compressor T-slot with molded tabs in lower cover.

3.7 Reverse Acting (REMOVE ALL LINE PRESSURE)

3.7.1 Valve Diaphragm Replacement

- 3.7.1.1 Load the bottom chamber of the actuator with sufficient air to partially open valve. This will ease the spring tension holding the valve diaphragm to the body weir.
- 3.7.1.2 Remove the bonnet bolts. Lift actuator assembly from valve body. Release air and disconnect air line.
- 3.7.1.3 Unscrew diaphragm from compressor by turning counterclockwise.
- 3.7.1.4 For PTFE assemblies only: Replace backing cushion and PTFE diaphragm.
Note: To engage the threads of the diaphragm stud invert the PTFE diaphragm. To invert the diaphragm, press on the center of the diaphragm face with thumbs while holding the edge of the diaphragm with fingers.
- 3.7.1.5 Screw new diaphragm into compressor by turning hand tight. **DO NOT OVERTIGHTEN.** Then back off until bolt holes in diaphragm and bonnet flange register.
- 3.7.1.6 Connect air line to lower air chamber and load chamber with sufficient air to move the diaphragm upward until the backing cushion or elastomer diaphragm rests against the

Advantage Act. lower cover. Do not apply excessive air pressure that results in inversion of the diaphragm.

- 3.7.1.7 Replace actuator assembly on body, and tighten bonnet bolts hand tight.
- 3.7.1.8 Tighten bonnet bolts with a wrench, crisscrossing from corner to corner. See Table 1 for recommended torques.
- 3.7.1.9 Apply sufficient air pressure to the lower cover to fully open the valve. If necessary, retighten bonnet bolts.
- 3.7.1.10 Travel stop (Closing Stop), if equipped, must be reset at this time to assure proper closure. See Section 4.1.

3.7.2 Actuator Diaphragm or Spring Replacement:
(1/4" through 2", DIN 8 - 50) If present, the switch package must be removed.

Spring-to-Close actuators contain powerful springs and should not be disassembled unless properly fixtured.

One fixture exists for 1/2", 3/4", and 1" (DIN 15, 20, 25) sizes, and another one for 1.5" and 2" (DIN 40 and 50) sizes. No special fixtures are required for the 3" & 4" (DIN 80 & 100) sizes. Consult factory for details, see Figure 7.

- 3.7.2.1 Remove actuator from the valve body. Apply air to lower cover to simplify disassembly, then release air.
- 3.7.2.2 Remove valve diaphragm and plastic indicator spindle plug (found on the 1/4" through 2" (DIN 8 - 50) spindles), both unthread by turning counterclockwise.
- 3.7.2.3 Position actuator centrally in fixture, locating the compressor over the correct spacer in the fixture lower plate.
- 3.7.2.4 Drop the stem guide through center of fixture handwheel and position in actuator indicator spindle #10-24 UNC tapped hole (former plug location).
- 3.7.2.5 Turn handwheel clockwise until stop rests on actuator top cover.
- 3.7.2.6 Remove all cover to cover caps, bolts, and washers.
- 3.7.2.7 Turn handwheel counterclockwise until spring load is relieved.
- 3.7.2.8 Remove top cover, lift out spring(s), unthread indicator spindle, remove top actuator plate and diaphragm.
- 3.7.2.9 Replace parts using the following procedure: Place the correct spacer, dependent on valve size, over the pin in the fixture lower plate. The 1 1/2"

and 2" (DIN 40 & 50) sizes require four (4) threaded rod guides in the lower cover prior to assembly. Position the actuator sub-assembly, including spring(s) and top cover, over the spacer (i.e., the compressor rests on the spacer). Drop the stem guide through center of the fixture handwheel, actuator top cover, and locate in the actuator indicator. Position the upper actuator cover so the 1/8" NPT inlets in the upper and lower covers are in line and the rod guides slide through the clearance holes. Turn the handwheel clockwise to compress the spring(s) until the covers almost touch. Remove the four(4) threaded rod guides. Start the cover bolts and then continue to compress the spring(s) until the covers touch. Place remaining washers and bolts in top cover and tighten bolts to torques shown in Table 1.

3.7.3 Actuator Diaphragm or Spring Replacement (3" & 4" Series 47, DIN 80 & 100)

If present, the switch package must be removed.

- 3.7.3.1** Disconnect air lines. It is best to remove the bonnet bolts, lift actuator assembly from the valve body and move the unit to a bench. Remove clear plastic cap, travel stop nuts, roller-bearing and races.
- 3.7.3.2 Turn adjusting bushing clockwise until contact is made with spring package, **record the number of turns**. Remove actuator bolts and nuts, lift off top cover. Unscrew spring package from valve spindle by turning counterclockwise.
- 3.7.3.3 Remove spindle nut, diaphragm top plate and actuator diaphragm.
- 3.7.3.4 Install new diaphragm, top hat up. Reassembly is the reverse of the above, use Blue Loctite #242 on the spindle nut. If the original spring package is used, turn the adjusting bushing counterclockwise the number of turns recorded in 3.7.3.2. only after assembling the top cover and fasteners. Should replacement of the spring package be required, simply thread the new spring package onto the valve spindle. A gap may exist between the covers until properly bolted together using a crisscross pattern. See Table 1 for fastener torques.

(3" & 4" Series 33, DIN 80 & 100)

- 3.7.3.5** Disconnect air lines. It is best to remove the bonnet bolts, lift actuator assembly from the valve body and move the unit to a bench. Remove actuator bolts and remove top cover.

- 3.7.3.6 Unthread adjusting bushing, this relieves the spring load, until it is free of the valve spindle. Remove the adjusting bushing/spring plate sub-assembly and the springs. Remove spindle nut, top actuator plate and actuator diaphragm.

- 3.7.3.7** Install new diaphragm, top hat up. Be sure the diaphragm is positioned so the diaphragm bolt holes line up with the cover bolt holes with no stretching of the diaphragm. The compressor should extend 0.72" from the bonnet face in this relaxed position, reference p. 10 for a view of the compressor position. Re-assembly is the reverse of the above, use Blue Loctite #242 on the spindle nut. Thread the adjusting bushing down until it shoulders. A gap will exist between the covers until properly bolted together using a criss-cross pattern. Use three long bolts to pull down the upper cover and pinch the diaphragm. Tighten the standard cover bolts, replace the three long bolts and complete the assembly. See Table 1 for fastener torques.

3.7.4 Spindle O-Ring Replacement (All sizes)

- 3.7.4.1 Disconnect air lines. Remove actuator from valve body and dismantle actuator following instructions above for removing actuator diaphragm and springs.
- 3.7.4.2 Withdraw valve diaphragm, compressor and spindle assembly from the bonnet.
- 3.7.4.3 Replace o-rings and reassemble by reversing the instructions and following the steps for replacing a valve diaphragm. Care must be used on the Bio-Tek to align the compressor T-slot with molded tabs in lower cover. Lubricate o-rings prior to installation per Section 3.4.

3.8 Direct Acting (REMOVE ALL LINE PRESSURE)

3.8.1 Valve Diaphragm Replacement

- 3.8.1.1 Disconnect air lines. Remove bonnet bolts, lift actuator assembly from valve body. Pressurize actuator by applying air to upper cover, extending compressor and diaphragm.
- 3.8.1.2 Unscrew diaphragm from compressor by turning counterclockwise.
- 3.8.1.3 For PTFE assemblies only: Replace backing cushion and PTFE diaphragm. **Note: To engage the threads of the diaphragm stud invert the PTFE diaphragm. To invert the diaphragm, press on the center of the**

diaphragm face with thumbs while holding the edge of the diaphragm with fingers.

- 3.8.1.4 Screw new diaphragm into compressor until hand tight. **DO NOT OVERTIGHTEN.** Then back off until bolt holes in diaphragm and bonnet register.
- 3.8.1.5 Reduce air pressure until back of diaphragm is flat against bonnet. Replace actuator and bonnet assembly on body, and tighten bonnet bolts hand tight.
- 3.8.1.6 Tighten bonnet bolts with a wrench, crisscrossing from corner to corner. See Table 1 for recommended torques.
- 3.8.1.7 Release air and permit the valve to open. If necessary, retighten bonnet bolts.
- 3.8.1.8 Travel stop, if equipped, must be reset at this time to assure proper closure. See Section 4.1.

3.8.2 Actuator Diaphragm or Spring Replacement:
(1/4" through 2", DIN 8 - 50)
If present, the switch package must be removed.

Spring-to-Open actuators contain powerful springs and should not be disassembled unless properly fixtured.

One fixture exists for the 1/2", 3/4", and 1" (DIN 15, 20, 25) sizes, and one for 1 1/2" and 2" (DIN 40 and 50) sizes.

No fixture required for 3" & 4"(DIN 80 & 100). Consult factory for details, see Figure 7.

- 3.8.2.1 Remove cover bolts and lift off top cover.
- 3.8.2.2 **Caution: actuator plates are under load.** Loosen the indicator spindle two turns before placing centrally in the fixture, locating the compressor over the correct spacer in the fixture lower plate. Place the slotted fixture plate and spacer plate on the actuator top plate; turn the fixture handwheel clockwise to remove the load from the indicator spindle. Remove the spindle and turn the handwheel counterclockwise until the spring load is relieved. Use care - the diaphragm may pinch the spindle thread and restrict spring extension. Examine the diaphragm through hole for damage and replace, if necessary.
- 3.8.2.3 Place the spring in the lower cover and set an actuator plate, concave side down, over the valve spindle. Position in the fixture over the spacer and place the slotted fixture plate on the actuator plate. Set the spacer plate on top, turn the fixture handwheel clockwise

and compress the spring until the actuator plate shoulders on the spindle. Use care to insure the spindle goes through the actuator diaphragm over the valve spindle using care to insure the top hat is in the upper cover. **Position the actuator diaphragm so the bolt clearance holes line up with threaded inserts in lower cover.** Place an actuator plate, concave side up, over the valve spindle. Apply Blue Loctite #242 and thread the indicating spindle on the valve spindle by hand. Turn the handwheel counterclockwise to remove the load and remove the actuator from the fixture. Clamp the slotted plate in a vise and pull so the actuator slips free. Tighten the indicator spindle with a wrench using care to insure the actuator diaphragm remains properly aligned.

- 3.8.2.4 Position the upper actuator cover so the 1/8" NPT inlets in the upper and lower covers are in line.

3.8.3 Actuator Diaphragm or Spring Replacement:
(3" & 4" Series 47, DIN 80 & 100) If present, switch package must be removed.

- 3.8.3.1** Disconnect air lines. It is best to remove the bonnet bolts, lift actuator assembly from the valve body and move the unit to a bench.
- 3.8.3.2 Remove clear plastic cap, travel stop nuts and roller bearing/races.
- 3.8.3.3 Remove actuator bolts and nuts, lift off top cover.
- 3.8.3.4 Remove adjusting bushing, spindle nut (under load due to spring force), diaphragm plates, actuator diaphragm and spring.
- 3.8.3.5 Using replacement parts, reverse instructions for reassembly. Use Blue Loctite #242 on the spindle nut. Be sure to set the adjusting bushing at the correct location (4.06" (10.31 cm) from top of the spindle nut to bottom of adjusting bushing), see Figure 1.

(3" & 4" Series 33, DIN 80 & 100)

- 3.8.3.6** Disconnect air lines. It is best to remove bonnet bolts, lift actuator assembly from the valve body and move the unit to a bench. Remove actuator bolts and remove top cover.
- 3.8.3.7 Remove extension spindle, both nuts, diaphragm top plate, actuator diaphragm and spring.
- 3.8.3.8 Reassembly is the reverse of the above,

use Blue Loctite #242 on the spindle nut. The diaphragm is to be assembled top hat up. See Table 1 for fastener torques.

3.8.4 Spindle O-Ring Replacement (All sizes)

- 3.8.4.1 Disconnect air lines. Remove actuator from valve body and dismantle actuator following instructions above for removing actuator diaphragm and spring.
- 3.8.4.2 Withdraw valve diaphragm, compressor and spindle assembly from the bonnet.
- 3.8.4.3 Replace o-rings and reassemble by reversing the instructions and following the steps for replacing a valve diaphragm. Care must be used on the Bio-Tek® to align the compressor T-slot with molded tabs in lower cover. Lubricate o-rings prior to installation per Section 3.4.

4 ACCESSORIES

4.1 Travel (Closing) Stop Adjustment

This feature is standard on 3" - 4" Series 47 (DIN 80-100) actuators and optional on the 1/4" - 2" (DIN 8-50). It is not available on 3" - 4" Series 33 (DIN 80-100).

The purpose of the travel stop is to prevent overloading of the diaphragm, thus prolonging diaphragm life. Travel stops are factory set and do not require routine adjustment. However, with replacement of valve diaphragms, travel stop adjustment is recommended.

4.1.1 All Operating Modes:

- 4.1.1.1 Remove switch Package if present.
- 4.1.1.2 Release air pressure in actuator covers.
- 4.1.1.3 Remove clear plastic cap.
- 4.1.1.4 To adjust travel (closing) stop, first loosen jam nuts and back off one turn. If double or direct acting, apply enough pressure in top cover to close the valve. While preventing the adjusting bushing from rotating, turn lower nut clockwise until valve leaks. Then turn lower nut counterclockwise until valve stops leaking while continuing to insure the adjusting bushing does not rotate. Tighten jam nuts together, the travel stop is now set. Replace plastic cap.

4.2 Combination Manual Over-ride (Open) and Adjustable Opening Stop

(Manual Over-ride (Open) not available on 1/4" through 2", DIN 8 - 50 or 3" & 4", DIN 80 - 100 Series 33.)

4.2.1 Operation of Manual Over-ride (Open): (3" & 4" Series 47 only, DIN 80 & 100 only)

- 4.2.1.1 Remove switch Package if present.
- 4.2.1.2 Release any air pressure in top cover.
- 4.2.1.3 Remove clear plastic cap and loosen jam nuts.
- 4.2.1.4 Use a wrench to hold the adjusting bushing from rotating, turn the lowest jam nut clockwise. This opens the valve 0.056" (1.42 mm) per rotation. Rotate the nut counterclockwise to return valve to closed position. **Note: Travel stop adjustment is recommended at this time. See Section 4.1 to adjust travel stop.**
- 4.2.1.5 Tighten jam nuts together and assemble plastic cap.

4.2.2 Operation of Adjustable Opening Stop: (1/4" through 2", DIN 8 - 50)

- 4.2.2.1 Remove switch package if present.
- 4.2.2.2 Using air pressure and bleed type regulator, open valve to desired position.
- 4.2.2.3 Rotate adjusting bushing counterclockwise until resistance is felt.
- 4.2.2.4 Opening stop is now set. **NOTE: VALVE CLOSED SWITCH REQUIRES ADJUSTMENT.**

4.2.3 Operation of Adjustable Opening Stop: (3" & 4" Series 47, DIN 80 & 100)

- 4.2.3.1 Remove switch package if present.
- 4.2.3.2 Remove clear plastic cap.
- 4.2.3.3 Using air pressure and bleed type regulator, open valve to desired position.
- 4.2.3.4 Rotate adjusting bushing counterclockwise until resistance is felt. Count and record the number of turns.
- 4.2.3.5 Loosen the two jam nuts and turn the lower nut clockwise the same number of turns recorded above. Lock the nuts together. **Note: Travel stop adjustment is recommended at this time. See Section 4.1 to adjust travel stop.**
- 4.2.3.6 Replace cap.

4.3 Combination Manual Over-ride (Close) and Adjustable Opening Stop

(Wrench closing not available on 1/4" through 2", DIN 8 - 50 or 3" & 4", DIN 80 & 100, Series 33.)

- 4.3.1 Operation of Manual Over-ride (Close): (3" & 4" Series 47 (DIN 80 & 100) Direct & Double only)

ADVANTAGE® ACTUATOR

FIGURE 1
1/4" - 2"
(DIN 8-50)

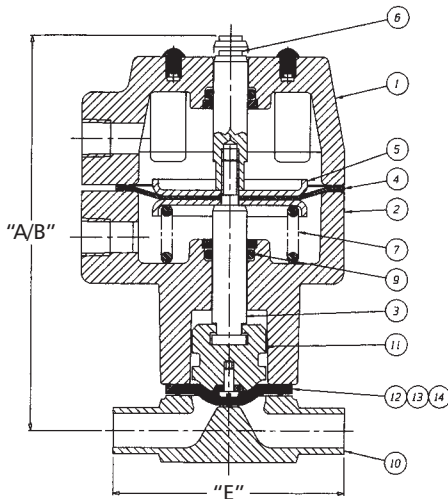
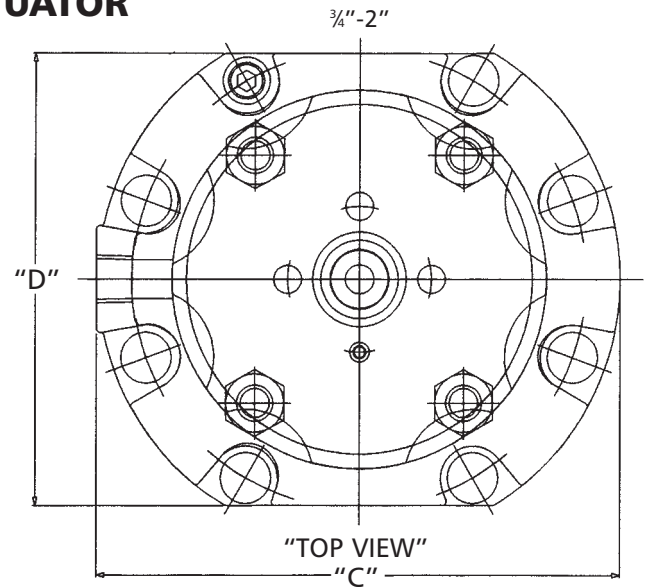
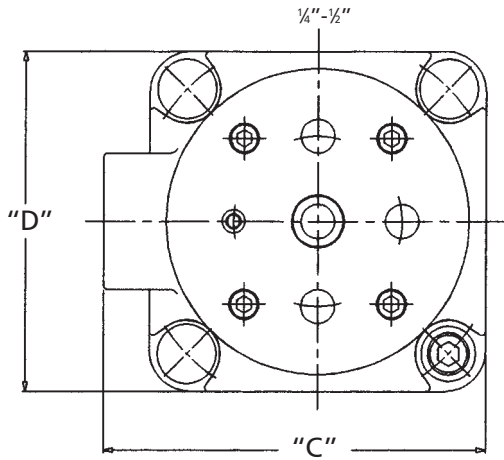

**DOUBLE ACTING
&
SPRING TO OPEN AIR CLOSE**

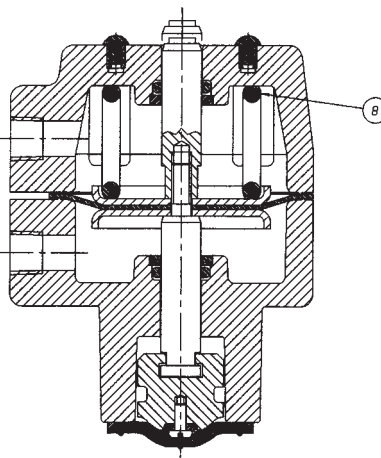

SPRING TO CLOSE AIR TO OPEN

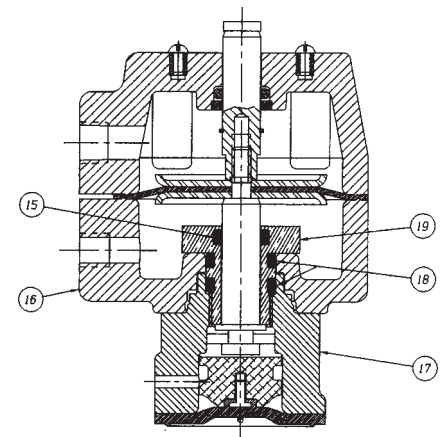

LOW PROFILE

LIST OF PARTS							
ITEM	DESCRIPTION	MATERIAL	QTY	ITEM	DESCRIPTION	MATERIAL	QTY
1	COVER, UPPER ACTUATOR	PAS, CMPL WITH FDA CFR #21	1	11	COMPRESSOR	S.S., C.I. ZINC OR BRONZE	1
2	COVER, LOWER ACTUATOR	PAS, CMPL WITH FDA CFR #21	1	*12	DIAPHRAGM, ELASTOMER	EPDM, CMPL WITH FDA CFR #21	1
3	SPINDLE, VALVE	S.S., ASTM A-582, TYPE 303	1	*13	DIAPHRAGM, PLASTIC	TFE CMPL WITH FDA CFR #21	1
*4	DIAPHRAGM, ACTUATOR	BUNA-N	1	*14	CUSHION, BACKING	EPDM, CMPL WITH FDA CFR #21	1
5	PLATE, ACTUATOR	S.S OR CAR STL NICKLE PL	2	*15	O-RING	VITON, CMPL WITH FDA CFR #21	1
6	SPINDLE, INDICATING	S.S., ASTM A-582, TYPE 303	1	16	COVER, LOWER ACTUATOR	PAS CMPL WITH FDA CFR #21	1
7	SPRING	STL, ASTM, A-401 EPOXY COAT	1	17	BONNET	S.S. ASTM A-351 CF8M	1
8	SPRING	STL, ASTM A-401 EPOXY COAT	1	*18	O-RING	VITON, CMPL WITH FDA CFR #21	2
*9	O-RING	VITON, CMPL WITH FDA CFR #21	2	19	BUSHING	BRASS	1
10	BODY, WEIR 1/4" - 2"	S.S., FORGED, ASTM A-182-F316L,S9	1				

*RECOMMENDED SPARE PARTS

Dimensional Data

Valve Size		"A" Valve Open		"B" With Switch Pack		"C"		"D"		"E" PureFlo® Body	
In	mm	In	mm	In	mm	In	mm	In	mm	In	mm
1/4, 3/8, 1/2	8, 10, 15	4.27	108	9.33	237	2.84	72	2.50	64	2.53	64
1/2	15	4.89	124	10.00	254	3.34	85	3.00	76	3.50	89
3/4	20	5.93	151	11.00	279	4.56	116	3.88	99	4.00	102
1	25	6.55	166	11.41	290	4.56	116	3.88	99	4.50	114
1 1/2	40	10.62	270	15.06	383	6.41	163	5.94	151	5.50	140
2	50	11.39	289	15.50	394	6.41	163	5.94	151	6.25	159
3 (33)	76	16.42	417	19.98	508	10.57	269	N/A	N/A	8.75	222
4 (33)	102	17.47	444	21.06	535	10.57	269	N/A	N/A	11.50	292
3 (47)	76	21.53	547	27.14	689	14.00	356	N/A	N/A	8.75	222
4 (47)	102	23.25	591	28.86	733	14.00	356	N/A	N/A	11.50	292

ADVANTAGE® ACTUATOR

3" - 4" (SERIES 47)

(DIN 80-100)

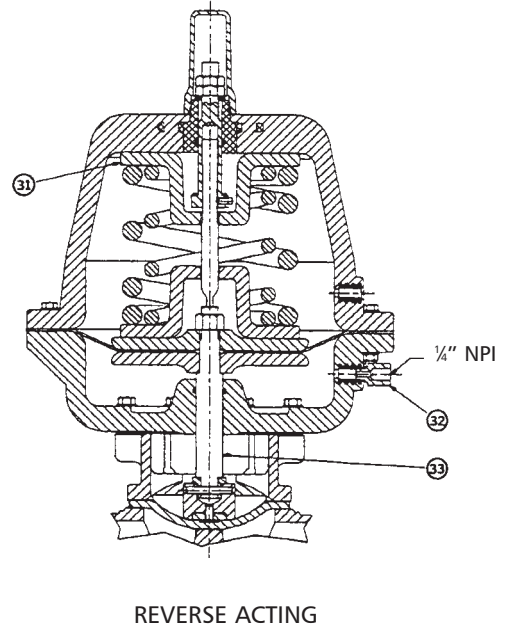
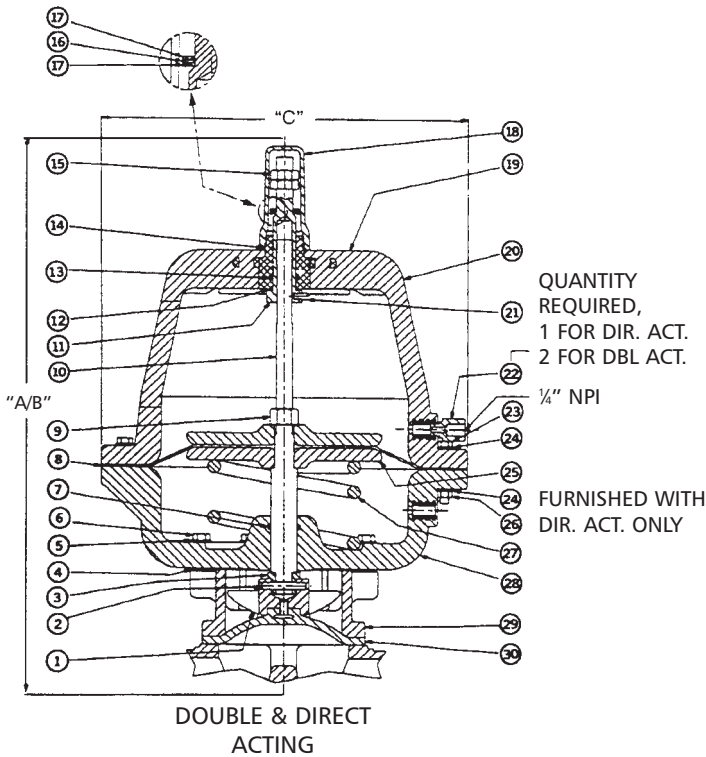

LIST OF PARTS			
ITEM	DESCRIPTION	MATERIAL	QTY.
1	COMPRESSOR	C.I. OR BRZ.	1
2	PIN	STN STL	1
3	COLLAR-STOP	STL	1
*	4 GASKET	EPDM	1
5	WASHER	STN STL	8
6	CAP SCREW	CARBON STL	8
*	7 O-RING	BUNA-N	1
*	8 DIAPHRAGM-ACTUATOR	BUNA-N	1
9	HEX NUT (SPINDLE NUT)	CARBON STL	1
10	SPINDLE (DIRECT, DOUBLE)	STN STL	1
11	BUSHING-ADJUSTING	STN STL	1
12	WASHER-THRUST	NYLON	1
*	13 O-RING	BUNA-N	1
*	14 O-RING	BUNA-N	1
15	JAM NUT	STN STL	2
16	BEARING-THRUST	STL	1
17	RACE-THRUST	STL	2
18	CAP	ACRYLIC	1
19	DECAL-LABEL	MYLAR	1
20	COVER-UPPER	VINYL-ESTER	1
21	SPRING PLUNGER	STN STL	1
22	ADAPTER	STN STL	AR
23	CAP SCREW	STN STL	16
24	WASHER	STN STL	32
25	PLATE-ACTUATOR	DI	2
26	HEX NUT	BRASS	16
27	SPRING	STL	1
28	COVER-LOWER	VINYL-ESTER	1
29	BONNET	DI	1
*	30 DIAPHRAGM	AS REQUIRED	1
31	SPRING PACK ASSY (REVERSE)	—	1
32	ADAPTER	STN STL	1
33	SPINDLE (REVERSE)	STN STL	1

* RECOMMENDED SPARE PARTS

**TRAVEL, STOP, ADJUSTABLE OPENING
STOP & MANUAL OVER-RIDES**
FIGURE 2
3" - 4" (SERIES 47)
(DIN 80-100)

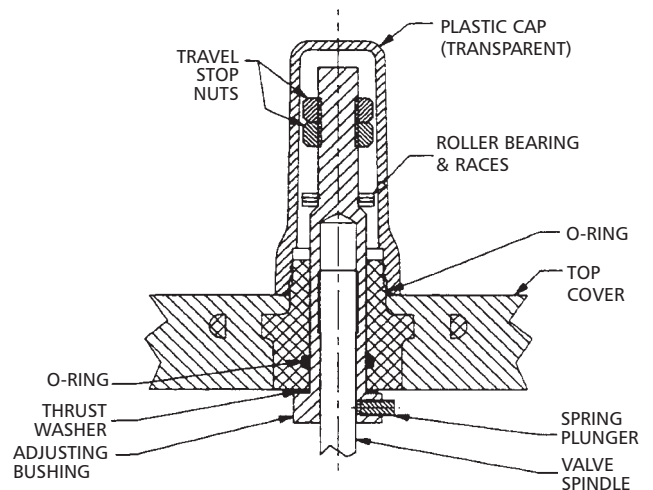

ADVANTAGE® ACTUATOR

3" - 4" (SERIES 33)

(DIN 80-100)

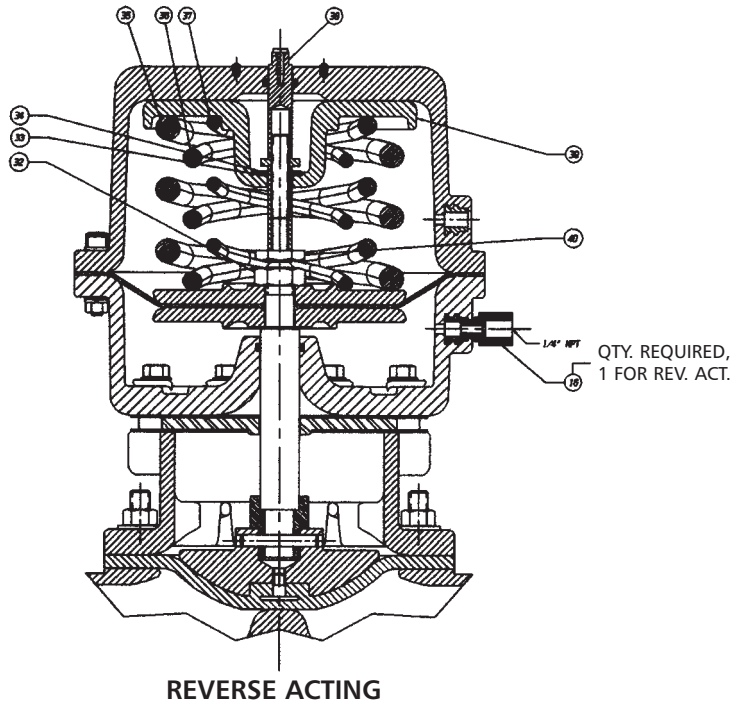

LIST OF PARTS			
ITEM	DESCRIPTION	MATERIAL	QTY.
1	COVER-UPPER	VINYL ESTER	1
2	COVER-LOWER	VINYL ESTER	1
3	PLATE-ACTUATOR	DI	2
* 4	DIAPHRAGM-ACTUATOR	BLNA-N	1
5	SCREW-CAP	STL	8
6	WASHER	STL	8
7	SCREW-HEX SDC HD CAP	STN STL	12
8	WASHER	STN STL	24
9	NUT	STN STL	12
* 10	GASKET	EPDM	2
* 11	O RING	BLNA-N	1
* 12	O RING	BLNA-N	1
13	PLATE-SUPPORT	STN STL	1
14	SPINDLE	STN STL	1
15	CAP	PLASTIC	12
16	ADAPTER	STN STL	AR
17	BONNET	DI	1
18	SCREW-RD HD MACH	STN STL	4
19	LABEL	MYLAR	1
20	PLUG	PLASTIC	1
21	WASHER	STN STL	AR
22	NUT	STN STL	AR
23	COMPRESSOR	CT OR BRZ	1
24	PIN	STN STL	1
* 25	DIAPHRAGM	AS REQUIRED	1
26	BOLT-STUD	STN STL	AR
27	WASHER-LOCK	STN STL	12
28	SPRING	STL	1
29	NUT	STL	2
30	SPINDLE-EXTENSION	STN STL	1
31	WASHER	STL	1
32	NUT	STL	1
33	RACE-THRUST	STL	1
34	BEARING-THRUST	STL	1
35	SPRING	STL	1
36	SPRING	STL	1
37	SPRING	STL	1
38	BUSHING-ADJUSTING	STN STL	1
39	SPRING PLATE	DI	1
40	LOCKNUT	STL	1

* RECOMMENDED SPARE PARTS
 ITEMS 1 - 27 COMMON PARTS
 ITEMS 28 - 31 FOR DOUBLE AND DIRECT ONLY
 ITEMS 32 - 40 FOR REVERSE ONLY

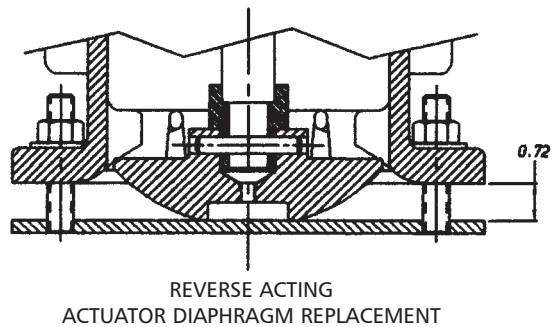
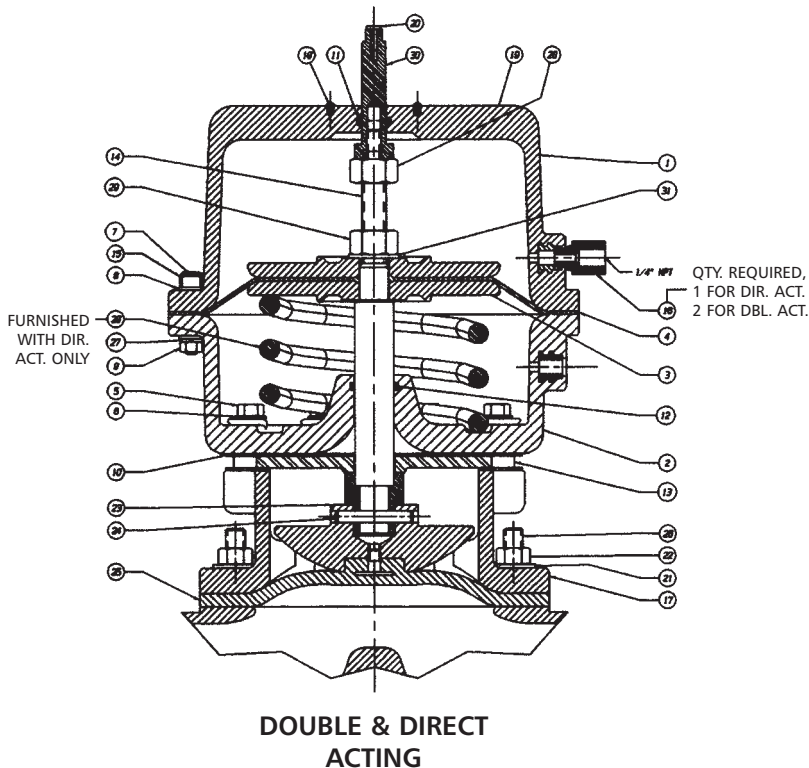

- 4.3.1.1 If present, the switch package must be removed.
- 4.3.1.2 Release any air pressure in bottom cover.
- 4.3.1.3 Remove clear plastic cap.
- 4.3.1.4 Use a wrench to turn the adjusting bushing counter clockwise to close the valve (record the number of turns). Turn the adjusting bushing clockwise the same number of turns to return valve to open position.
- 4.3.1.5 Tighten Travel Stop nuts and assemble plastic cap.

5 SWITCH PACK 2.0

(The switch package is not autoclavable, maximum temperature is 150° F 65.5°C) (Switches and Positioners cannot be used together)

Retrofit - The switch package as received from the factory is pre-set, only minimal adjustment is required to adapt to the actuator.

5.1 Field Mounting (1/4" through 2", DIN 8 - 50, 3" & 4", DIN 80 & 100, Series 33)

- 5.1.1 Remove the four(4) stainless steel screws on the actuator top cover. Place the valve in the open position.
- 5.1.2 Remove the plastic plug from the indicating spindle.
- 5.1.3 Thread the switch indicating spindle into the valve indicating spindle. Use Blue Loctite #242.
- 5.1.4 Mount the adapter, insure that both O-Rings are on the adapter and lubricated with Dow 111. The correct torque is 5 in-lbs (.656 Joules).
- 5.1.5 Slide the switch sub assembly down over the adapter, position the conduit entrances in the location most desirable, (45° increments), press down and tighten the set screw located on the side of the lower housing to lock the unit in place. The set screw torque should not exceed 5 in-lbs (.656 Joules).
- 5.1.6 Holding the lower housing stationary, unscrew the top switch package cover and wire to the terminal strip (Reference factory wiring decal). Verify the switches operate correctly by cycling the valve, see 5.3 for switch adjusting procedure. Screw the switch package cover on, insure the O-Ring remains in the groove.

5.2 Field Mounting (3" and 4" Series 47, DIN 80 and 100)

- 5.2.1 Remove the clear plastic cap from the actuator.
- 5.2.2 Thread the switch indicating spindle into the valve indicating spindle. Use Blue Loctite #242.

- 5.2.3 Thread on the adapter, insure that the O-Ring is in place at the base of the adapter.
- 5.2.4 Slide the switch sub assembly down over the adapter, position the conduit entrances in the location most desirable, (45° increments), press down and tighten the set screw located on the side of the lower housing to lock the unit in place. The set screw torque should not exceed 5 in-lbs (.656 Joules).
- 5.2.5 Holding the lower housing stationary unscrew the top switch package cover and wire to the terminal strip (Reference factory wiring decal). Verify the switches operate correctly by cycling the valve, see 5.3 for switch adjusting procedure. Screw the switch package cover on, insure the O-Ring remains in the groove.

5.3 Setting Switches

(Switches are identified with decal)

- 5.3.1 Remove top switch package cover.
- 5.3.2 Place valve in full open position.
- 5.3.3 Connect test device to terminal strip on connections identified for SW (open) switch. The switch type, inductive proximity versus dry contact mechanical, determines the type of test device required. Contact switches use a traditional volt meter with resistance capability to verify continuity, inductive proximity switches cannot use this method. Proximity switches require an inductive proximity tester, such as Pepperl+Fuch's model #1-1305, which supplies the proper load and supply voltage to the switch. Inductive proximity switches must be energized with the correct load and supply voltage to sense the target.

WARNING: DO NOT SHORT THE INDUCTIVE PROXIMITY SWITCH BY DIRECTLY CONNECTING A POWER SUPPLY, IRREPARABLE AND IMMEDIATE DAMAGE CAN OCCUR TO THE SWITCH.

- 5.3.4 Loosen the two (2) screws on the open switch slightly.
- 5.3.5 Use the adjusting screw accessible from the top to move the switch up or down the bracket to the optimum position. (Two turns past the trigger location is recommended.)
- 5.3.6 Tighten the two (2) screws on the switch.
- 5.3.7 Place the valve in the full closed position.
- 5.3.8 Repeat the above steps for the SW (closed) switch.
- 5.3.9 Replace the top switch package cover.

6 SWITCH PACK 2.5

(The switch package is not autoclavable, maximum temperature is 150°F, 65.5°C) (Switches and Positioners cannot be used together)

SWITCH PACK 2, SP2.0 FIGURE 3

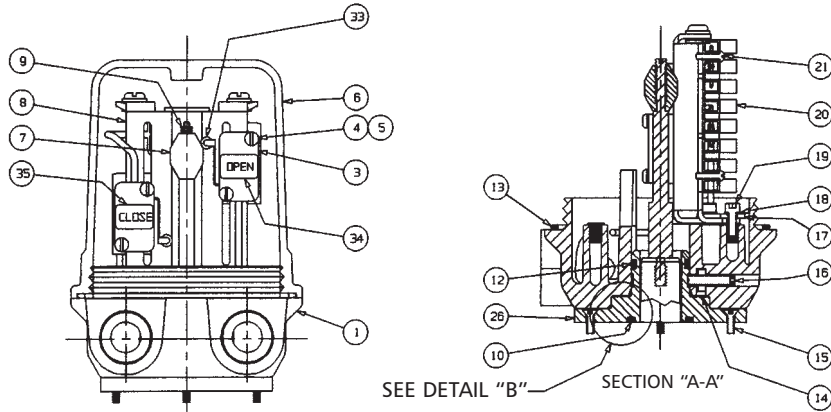
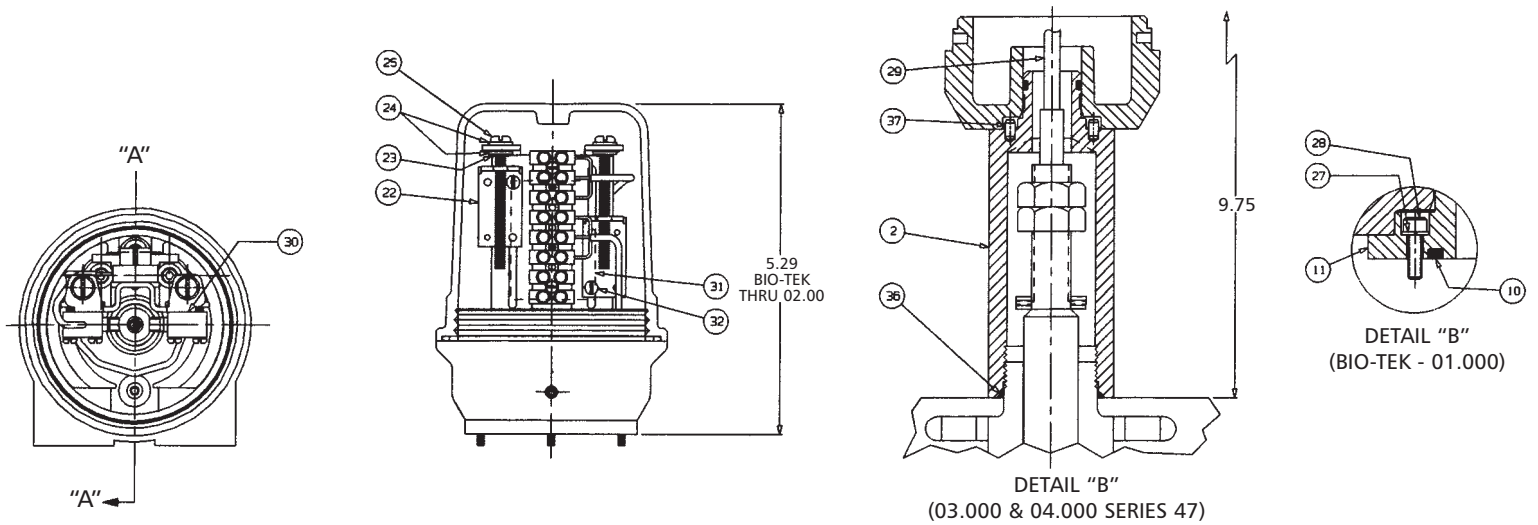

NOTE:

1. RECOMMENDED SPARE PARTS ARE MARKED WITH AN ASTERISK (*) ON THE LIST OF PARTS.
- ▲ - USED ON BIO-TEK - 01.000
+ - USED ON BIO-TEK - 02.000
◆ - USED ON 1.500 & 02.000
Φ - USED ON 03.000 & 04.000
- Δ 3. SWITCHES
PROX P&F #NJ3-V3-Z
PROX P&F #NJ3-V3-N
PROX P&F #NJ3-V3-E
PROX P&F #NJ3-V3-E2
MECH #X97173-V3L (SIL CONT)
MECH #X97174-V3L (GOLD CONT)
- 4. USED ONLY WITH PROXIMITY SWITCHES.
- ↑ 5. USED ONLY WITH MECHANICAL SWITCHES

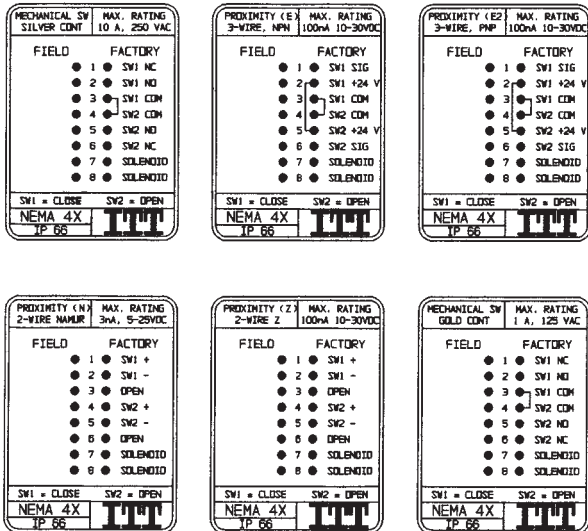

WIRING LABELS (ITEM 31)

LIST OF PARTS			
ITEM	DESCRIPTION	MATERIAL	QTY.
1	HOUSING-LOWER	PAS	1
2	ADAPTER-SWITCH	STN STL,A-582, TY 303	1
3	SWITCH	-	2
4	SCREW-PAN HD MACH #4-40UNC X .62 LG	STN STL,18-8	4
5	WASHER-SPRING LOCK #4 REGULAR	STN STL,18-8	4
6	HOUSING-UPPER	PAS	1
7	ACTUATOR-SWITCH	ALLUM,B-211-6061-T6	1
8	BRACKET-SWITCH MTG	STN STL,A-240, SERIES 300	1
9	ROD-SWITCH ACTUATOR	STN STL,A-582, TY 303	1
10	O-RING #117	BUNA-N,FDA COMPLIANT	1
11	ADAPTER-SWITCH	PAS	1
12	O-RING #116	BUNA-N,FDA COMPLIANT	1
13	O-RING #152	BUNA-N,FDA COMPLIANT	1
14	NUT-SQUARE #8-32UNC	STN STL,18-8	1
15	SCREW-FL HEX SDC HD #4-40UNC X .38	STN STL,18-8	4
16	SCREW-HEX SDC SET #8-32UNCX.75KN CP	STN STL,18-8	1
17	WASHER-PLAIN #6 TYPE A	STN STL,18-8	3
18	WASHER-SPRING LOCK #6 REGULAR	STN STL,18-8	3
19	SCREW-HEX SDC HD CAP #6-32UNC X .38	STN STL,18-8	3
20	TERMINAL STRIP	-	1
21	SCREW-PAN HD MACH #3-48UNC X .38 LG	STN STL,18-8	2
22	BRACKET-ADJUSTING	STN STL,A-240, SERIES 300	2
23	RING-RETAINING TRUARC #5133-14	STL	2
24	WASHER-PLAIN #8 TYPE B NARROW	STN STL,18-8	4
25	SCREW-MODIFIED	STN STL,18-8	2
26	ADAPTER-SWITCH	PAS	1
27	WASHER-SPRING LOCK #4 REGULAR	STN STL,18-8	4
28	SCREW-HEX SDC HD CAP #4-40UNCX.375	STN STL,18-8	4
29	ROD-SWITCH ACTUATOR	STN STL,A-582, TY 303	1
30	INSULATOR-SWITCH	NOMEX ARAMID	2
31	LABEL-SWITCH PACK	MYLAR	1
32	SCREW-RND HD MACH #4-40UNCX.125 LG	STN STL,18-8	2
33	SWITCH-ACTUATOR #JV-5	STN STL	2
34	LABEL-SWITCH (OPEN)	MYLAR	1
35	LABEL-SWITCH (CLOSE)	MYLAR	1
36	O-RING #128	BUNA-N,FDA COMPLIANT	1
37	PIN-SPIROL .158 DIA X .312 LG	STN STL	2

Retrofit - The switch package as received from the factory is pre-set, only minimal adjustment is required to adapt to the actuator.

6.1 Field Mounting (1/4" through 1", DIN 8 - 25)

- 6.1.1 Remove the four(4) stainless steel screws on the actuator top cover. Place the valve in the open position.
- 6.1.2 Remove the plastic plug from the indicating spindle.
- 6.1.3 Mount the adapter, insure that both O-Rings are on the adapter and lubricated with Dow 111. The correct torque is 5 in-lbs (.565 Joules).
- 6.1.4 Place the washer on the adapter. Thread the switch indicating spindle (item 12) into the actuator spindle. Use Blue Loctite #242.
- 6.1.5 Slide the switch sub assembly down over the adapter, position the conduit entrances in the location most desirable, (45° increments), press down and tighten the set screw located on the side of the lower housing to lock the unit in place. The set screw torque should not exceed 5 in-lbs (.565 Joules).
- 6.1.6 Attach target assembly (item 9) to switch indicating spindle (item 12) using shoulder screw with Belleville washers in place. Use Blue Loctite #242. Run field wires and conduit to terminal strip. (Reference factory wiring tag.) Verify the switches operate correctly by cycling the valve, see 6.2 for switch adjusting procedure. Screw the switch package cover on, insure the O-Ring remains in the groove.

6.2 Setting Switches

(Switches are identified with decal)

- 6.2.1 Remove top switch package cover.
- 6.2.2 Place valve in full open position.
- 6.2.3 Connect test device to terminal strip on connections identified for open switch. The switch type, inductive proximity versus dry contact mechanical, determines the type of test device required. Contact switches use a traditional volt meter with resistance capability to verify continuity, inductive proximity switches cannot use this method. Proximity switches require an inductive proximity tester, such as Pepperl+Fuch's model #1 - 1350, which supplies the proper load and supply voltage to the switch. Inductive proximity switches must be energized with the correct load and supply voltage to sense the target.

WARNING: DO NOT SHORT THE INDUCTIVE PROXIMITY SWITCH BY DIRECTLY CONNECTING A POWER SUPPLY, IRREPARABLE AND IMMEDIATE DAMAGE CAN OCCUR TO THE SWITCH.

- 6.2.4 Use the switch actuator (item 7) accessible from the top to set the optimum position. (Two

turns past the trigger location is recommended.)

- 6.2.5 Place the valve in the full closed position.

- 6.2.6 Replace the top switch package cover.

7 SWITCH PACK 3.0

(The switch package is not autoclavable, maximum switch temperature is 140°F, 60°C.) (Switches and Positioners cannot be used together.)

Retrofit - The switch package as received from the factory on valve assemblies is pre-set, only minimal adjustment is required to adapt to the actuator.

7.1 Field Mounting (1/4" through 2", DN 8 - 50)

- 7.1.1 Remove the four (4) stainless steel screws on the actuator top cover. Place the valve in the open position.
- 7.1.2 Remove the plastic plug from the indicating spindle.
- 7.1.3 Insure all O-Rings are on the adapter and lubricated with Dow 111. Slip the switch indicating spindle, #10-24 UNC threads first, through the adapter until the threads are exposed. Apply Blue Loctite #242 to the threads, thread the switch spindle into the actuator spindle until it shoulders.
- 7.1.4 Attach the adapter to the upper cover. The correct torque is 5 in-lbs (.565 Joules).
- 7.1.5 Thread the appropriate switch actuator(s) on the spindle.
- 7.1.6 Position the closed switch actuator approximately 0.14" (4 turns) from end of threads and position the open switch actuator approximately 0.25" (7 turns) below the top of the spindle, do not tighten the set screw.
- 7.1.7 Remove the switch package top cover, slide the sub assembly down over the adapter using care not to damage the switch internals (specifically the mechanical switch levers). Position the conduit entrance in the location most desirable, press down and tighten the set screw located on the side of the lower housing to lock the unit in place. Note that the plastic adapter has two molded counterbores. Locating the set screw in one of these holes provides maximum resistance to conduit rotation. The set screw torque should not exceed 5 in-lbs (.565 Joules).
- 7.1.8 Run field wires and conduit to the terminal strips. Verify the switches operate correctly by cycling the valve. See 7.2 for switch adjusting procedure. Screw the switch package top cover on.

7.2 Setting Switches

SWITCH PACK 2.5, SP2.5 FIGURE 3A

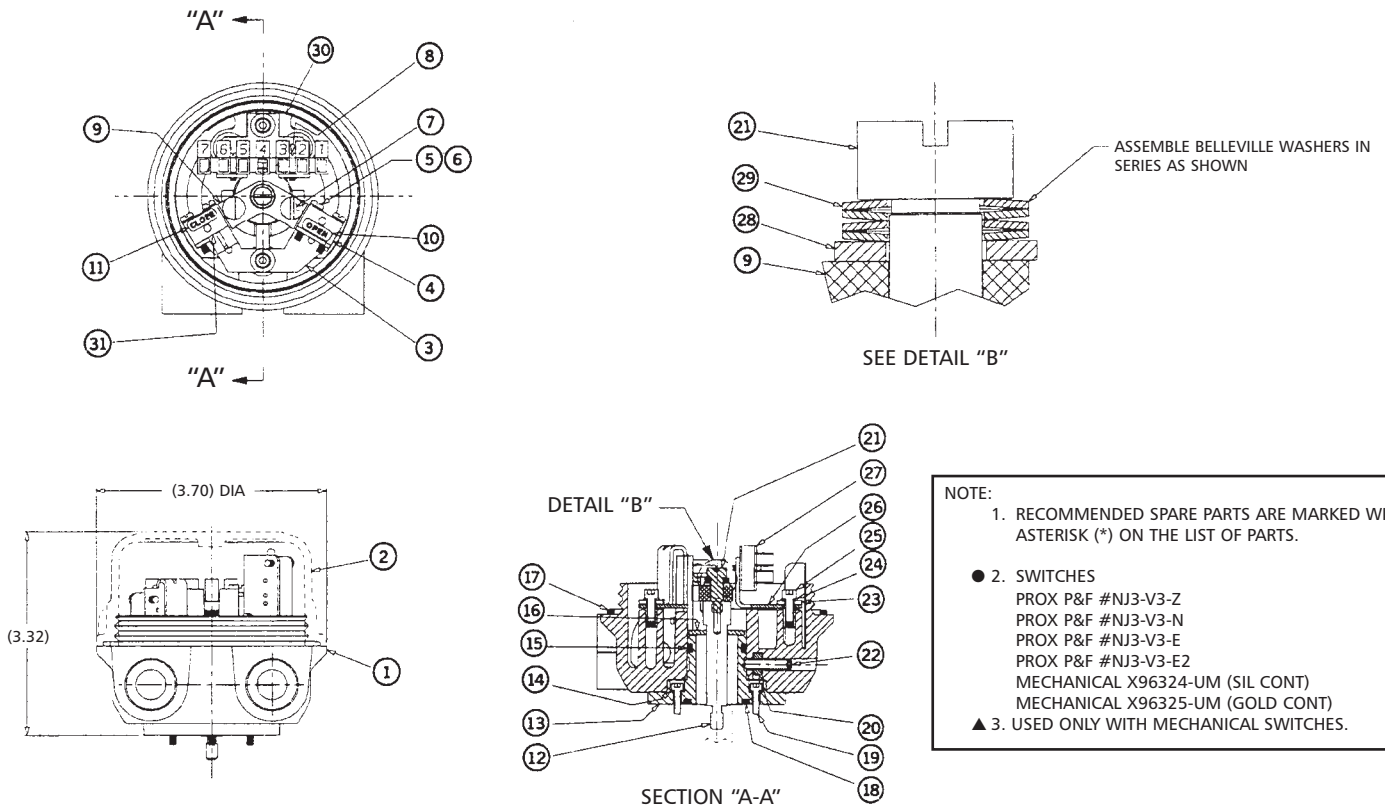

NOTE:

- RECOMMENDED SPARE PARTS ARE MARKED WITH AN ASTERISK (*) ON THE LIST OF PARTS.
- SWITCHES
 PROX P&F #NJ3-V3-Z
 PROX P&F #NJ3-V3-N
 PROX P&F #NJ3-V3-E
 PROX P&F #NJ3-V3-E2
 MECHANICAL X96324-UM (SIL CONT)
 MECHANICAL X96325-UM (GOLD CONT)
- USED ONLY WITH MECHANICAL SWITCHES.

ITT Engineered Valves		
TERM STRIP NO.		DESCRIPTION
1	NO OR NC	OPEN SWITCH
2	NO OR NC	CLOSE SWITCH
3	COMMON	OPEN & CLOSE SWITCH
4	---	NOT USED
5	SOLENOID	POWER (RED)
6	SOLENOID	POWER (RED)
7	SOLENOID	GROUND (GREEN) OPT.
MECHANICAL SWITCH SILVER CONTACTS	MAX. RATING 5A 250VAC	NEMA 4X

ITT Engineered Valves		
TERM STRIP NO.		DESCRIPTION
1	+	OPEN SWITCH
2	-	OPEN SWITCH
3	+	CLOSE SWITCH
4	+	CLOSE SWITCH
5	SOLENOID	POWER (RED)
6	SOLENOID	POWER (RED)
7	SOLENOID	GROUND (GREEN) OPT.
PROXIMITY (N) 2-WIRE NAMUR	MAX. RATING 3mA 250VDC	NEMA 4X

ITT Engineered Valves		
TERM STRIP NO.		DESCRIPTION
1	NO	OPEN SWITCH
2	NC	OPEN SWITCH
3	COMMON	OPEN & CLOSE SWITCH
4	NO	CLOSE SWITCH
5	NC	CLOSE SWITCH
6	---	NOT USED
7	---	NOT USED
MECHANICAL SWITCH SILVER CONTACTS	MAX. RATING 5A 250VAC	NEMA 4X

ITT Engineered Valves		
TERM STRIP NO.		DESCRIPTION
1	+	OPEN SWITCH
2	-	OPEN SWITCH
3	+	CLOSE SWITCH
4	+	CLOSE SWITCH
5	SOLENOID	POWER (RED)
6	SOLENOID	POWER (RED)
7	SOLENOID	GROUND (GREEN) OPT.
PROXIMITY (Z) 2-WIRE Z	MAX. RATING 100mA 10-30VDC	NEMA 4X

ITT Engineered Valves		
TERM STRIP NO.		DESCRIPTION
1	NO OR NC	OPEN SWITCH
2	NO OR NC	CLOSE SWITCH
3	COMMON	OPEN & CLOSE SWITCH
4	---	NOT USED
5	SOLENOID	POWER (RED)
6	SOLENOID	POWER (RED)
7	SOLENOID	GROUND (GREEN) OPT.
MECHANICAL SWITCH GOLD CONTACTS	MAX. RATING 0.1A 250VAC	NEMA 4X

ITT Engineered Valves		
TERM STRIP NO.		DESCRIPTION
1	SIGNAL	OPEN SWITCH
2	+24V	OPEN & CLOSE SWITCH
3	COMMON	OPEN & CLOSE SWITCH
4	SIGNAL	CLOSE SWITCH
5	SOLENOID	POWER (RED)
6	SOLENOID	POWER (RED)
7	SOLENOID	GROUND (GREEN) OPT.
PROXIMITY (E) 3-WIRE, NPN	MAX. RATING 100mA 10-30VDC	NEMA 4X

ITT Engineered Valves		
TERM STRIP NO.		DESCRIPTION
1	NO	OPEN SWITCH
2	NC	OPEN SWITCH
3	COMMON	OPEN & CLOSE SWITCH
4	NO	CLOSE SWITCH
5	NC	CLOSE SWITCH
6	---	NOT USED
7	---	NOT USED
MECHANICAL SWITCH GOLD CONTACTS	MAX. RATING 0.1A 250 VAC	NEMA 4X

ITT Engineered Valves		
TERM STRIP NO.		DESCRIPTION
1	SIGNAL	OPEN SWITCH
2	+24V	OPEN & CLOSE SWITCH
3	COMMON	OPEN & CLOSE SWITCH
4	SIGNAL	CLOSE SWITCH
5	SOLENOID	POWER (RED)
6	SOLENOID	POWER (RED)
7	SOLENOID	GROUND (GREEN) OPT.
PROXIMITY (E2) 3-WIRE, PNP	MAX. RATING 100mA 10-30VDC	NEMA 4X

LIST OF PARTS			
ITEM	DESCRIPTION	MATERIAL	QTY.
1	HOUSING-LOWER	PAS	1
2	HOUSING-UPPER	PAS	1
3	BRACKET-SWITCH MTG	STN STL	1
4	SWITCH	---	1
5	SCREW-PAN HD MACH	STN STL	4
6	WASHER-SPRING LOCK	STN STL	4
7	ACTUATOR-SWITCH	STN STL	2
8	SCREW-PAN HD MACH #3-48UNC X .38 LG	STN STL	2
9	PLATE-SWITCH ACTUATOR	UHMW	1
10	LABEL-SWITCH (OPEN)	MYLAR	1
11	LABEL-SWITCH (CLOSE)	MYLAR	1
12	SPINDLE EXTENSION	STN STL	1
13	ADAPTER-SWITCH	PAS	1
14	WASHER-SPRINGLOCK #4 REGULAR	STN STL	4
15	O-RING #116 BUNA-N, FDA	BUNA-N	1
16	WASHER-PLAIN 0.3125 TYPE B REGULAR	STN STL	1
17	O-RING #152 BUNA-N, FDA	BUNA-N	1
18	O-RING #117 BUNA-N, FDA	BUNA-N	1
19	SCREW-HEX SOC HD CAP #4-40UNCX0.375	STN STL	4
20	NUT-SQUARE #8-32UNC	STN STL	1
21	SCR-SHLDR .187 DIA X .375 LG: 8-32	STN STL	1
22	SCREW-HEX SOC SET #8-32UNCX.75KN CP	STN STL	1
23	WASHER-PLAIN #6 TYPE A	STN STL	2
24	WASHER-SPRING LOCK #6 REGULAR	STN STL	2
25	SCREW-HEX SOC HD CAP #6-32UNC X .38	STN STL	2
26	BRACKET-TERMINAL STRIP MTG	STN STL	1
27	TERMINAL STRIP	---	1
28	WASHER-SUPERIOR #10-406040	STN STL	1
29	WASHER-BELLEVILLE #A1-371915	STN STL	4
30	CARD-WIRING DIAGRAM	PLASTIC	1
31	INSULATOR-SWITCH	NOMEX ARAMID	2

WIRING DIAGRAM CARDS (ITEM 30)

- 7.2.1 Remove top switch package cover.
- 7.2.2 Place valve in full open position.
- 7.2.3 Connect test device to terminal strip for open switch. The switch type, inductive proximity versus dry contact mechanical, determines the type of test device required. Contact switches use a traditional volt meter with resistance capability to verify continuity, inductive proximity switches cannot use this method. Proximity switches require an inductive proximity tester, such as Pepperl+Fuch's model #1-1350, which supplies the proper load and supply voltage to the switch. Inductive proximity switches must be energized with the correct load and supply voltage to sense the target.

WARNING: DO NOT SHORT THE INDUCTIVE PROXIMITY SWITCH BY DIRECTLY CONNECTING A POWER SUPPLY, IRREPARABLE AND IMMEDIATE DAMAGE CAN OCCUR TO THE SWITCH.

- 7.2.4 Bio-1.50" (Two Switch Actuators)
 - 7.2.4.1 Verify the switch package locking set screw is tight.
 - 7.2.4.2 Verify the circuit board is firmly seated.
 - 7.2.4.3 For mechanical switches only, press on the top of the circuit board to move it toward the switch actuator. Thread the switch actuator two (2) turns past the initial switch indication.
 - 7.2.4.4 Lock in place with the set screw on switch actuator.
- 7.2.5 2.0" (One switch actuator)
 - 7.2.5.1 Do not set the switch in the open position, set the switch in closed position. Follow 7.2.4 with the valve in full closed position. Confirm open switch functions in full open position only after setting in closed position.
- 7.2.6 Place the valve in the full closed position and connect the appropriate test device to the terminal strip for valve CLOSE switch. Repeat section 7.2.4-7.2.5 for the valve CLOSED switch. Note on SP 3.0 units, the closed switch actuator must never hit the adapter in the closed position with body attached.

- 8.1.1 Moore 73N12F (A100 & A300 Series Actuators) (Direct Acting Positioner, Top Loading)
- 8.1.2 Moore 73NB (A200 Series Actuators) (Direct Acting Positioner, Bottom Loading)
- 8.1.3 Moore 73NFR (A100 & A300 Series Actuators) (Reverse Acting Positioner, Top Loading)

8.2 Supply and Instrument Pressures

- 8.2.1 Instrument input pressure range - as specified: 3-15 psi (.21 - 1.03 bar) (standard), 3-9 psi (.21-.62 bar), 6-30 psi (.41-2.07 bar) and others are optional.
- 8.2.2 Supply pressure: 3 psi (.21 bar) above required actuator pressure to a maximum of 90 psi (6.2 bar). A filtered air supply is recommended.
- 8.2.3 **Caution: Pressure in excess of 90 psi (6.2 bar) to any connection may cause damage.**

8.3 Description

The positioner is designed to operate a valve actuator to maintain the valve in a position determined by the control instrument. The above positioners are **direct acting** - with an increase in instrument pressure, the pressure to the actuator (positioner output) will increase or **reverse acting** - with an increase in instrument pressure, the pressure to the actuator (positioner output) will decrease. On a **bottom loading** positioner (73NB), output is connected to the actuator lower chamber via an external tube. Therefore, the valve will open as instrument pressure increases. The 73NB is the only unit which can have an O-ring in the actuator upper cover. All others operate on the concept that air feeds the upper cover by flowing down the indicating shaft and into the cover. **(This means that a field retrofit for Double and Direct units must have the O-ring removed and a special slotted adjusting bushing.)** Double Acting (A300 Series) require the lower actuator cover to be pre-loaded, use a bleed off type regulator with gauge. (This is standard when ITT supplies the assembly.)

8.4 Installation

The only task is to connect the supply and instrument air. All connections are 1/4" NPT. Use 1/4" O.D. tubing for the instrument connection, either 1/4" or 3/8" O.D. (6.35 or 9.52 mm) tubing for the supply connection. Blow out all piping before connections are made to prevent the possibility of dirt or chips entering the positioner. Use pipe sealant sparingly, and then only on the male threads. A non-hardening sealant is strongly recommended. Connect the positioner to a source of clean, dry oil-free air. A filtered and regulated air source is recommended.

Note: Synthetic compressor lubricants in the air stream at the instrument may cause the positioner to fail.

Note that a cushion loading regulator is furnished with 3300 series actuators and a tee in the supply connection is routed to this regulator, so an extra hookup is not required. The cushion loading regulator should be set at the minimum pressure required to open the valve wide open. Typically, this is 10 psi (0.69 bar) or less.

8 POSITIONERS

(Switches and Positioners cannot be used together)

(A special adjusting bushing is required for 3" & 4" (DIN 80 & 100) Actuators with positioners)

8.1 Scope: Top-mounted positioners listed below

SWITCH PACK 3.0, SP3.0

FIGURE 3B

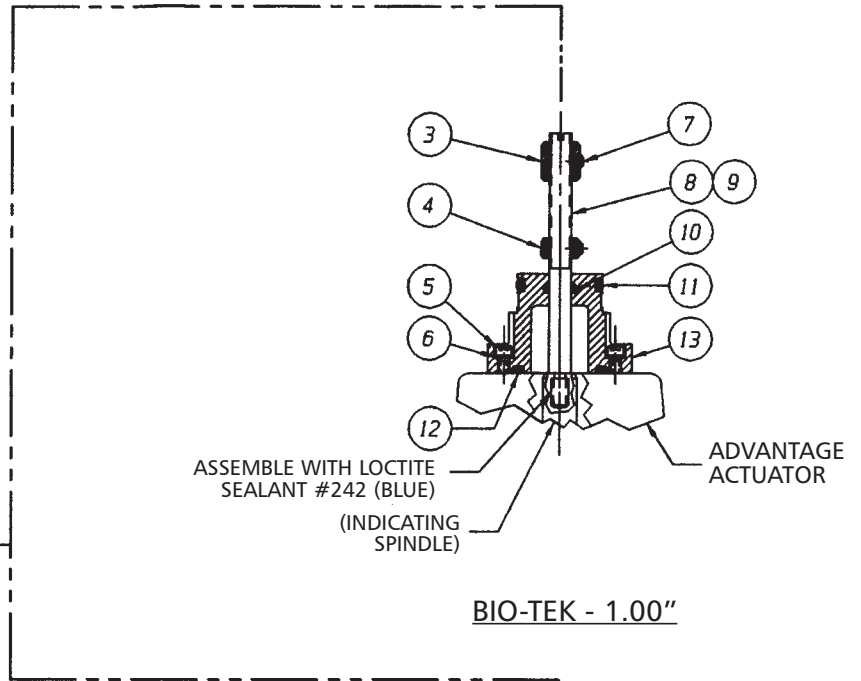
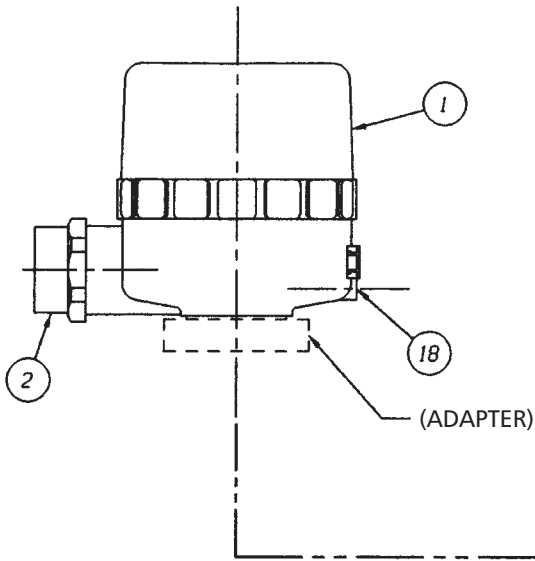

LIST OF PARTS	
ITEM	DESCRIPTION
1	SWITCH HOUSING
2	1/2" NPT ADAPTER
3	SWITCH ACTUATOR
4	SWITCH ACTUATOR
5	HEX SDC HD CAP SCREW
6	LOCKWASHER
7	SET SCREW
8	INDICATING SPINDLE
9	INDICATING SPINDLE
10	O RING #010
11	O RING #116
12	O RING #117
13	SWITCH ADAPTER
14	HEX SDC FLAT HD SCREW
15	SWITCH ADAPTER
16	INDICATING SPINDLE
17	INDICATING SPINDLE
18	SET SCREW KNURLED CLIP POINT

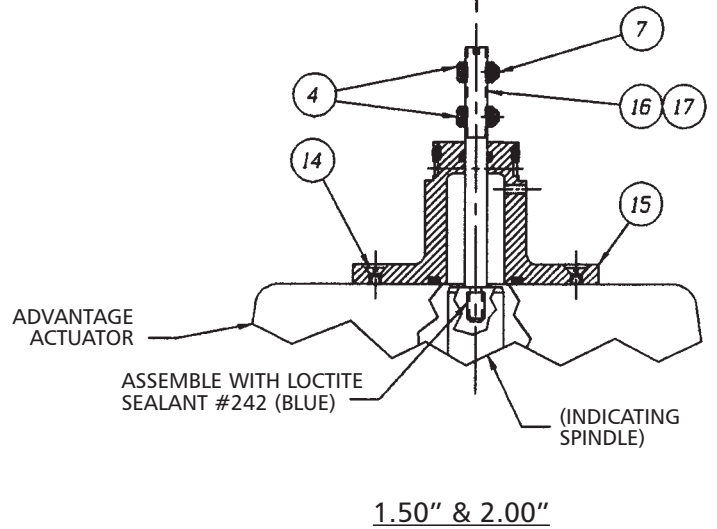

8.5 Adjustment

The only adjustment that can be made on the positioner is a zero adjustment. The zero adjusting screw is located under the positioner's top cover. To make this adjustment, set the instrument air pressure to the midpoint of its span, and turn the zero adjustment until the valve is at the mid-point of its stroke. Refer to Table #2 for stroke information. Recheck the setting accuracy by changing instrument air pressure to the maximum/minimum point to obtain full open/closed valve position.

In some cases, valve shut-off or opening may be required at a specific instrument pressure. To zero the positioner at this point, set the instrument signal at the specific pressure and turn the zero adjustment screw until the valve reaches the required position. A slight change of the instrument pressure should start to move the valve. The valve stroke for a given span may also be suppressed or shifted to the desired range by means of the zero adjusting screw.

8.6 Maintenance

A clean, oil and moisture free air supply will reduce maintenance problems. The supply air filter should be blown down on a routine basis. The filter element should be examined periodically and replaced if necessary. No lubrication is required on the valve positioner. The system should be shut down or the valve isolated from the system before service or removal of the positioner is accomplished.

For additional maintenance activities, refer to the Manufacturer's service manual.

POSITIONER FIGURE 4 $\frac{3}{4}$ " - 4" (DIN 20-100)

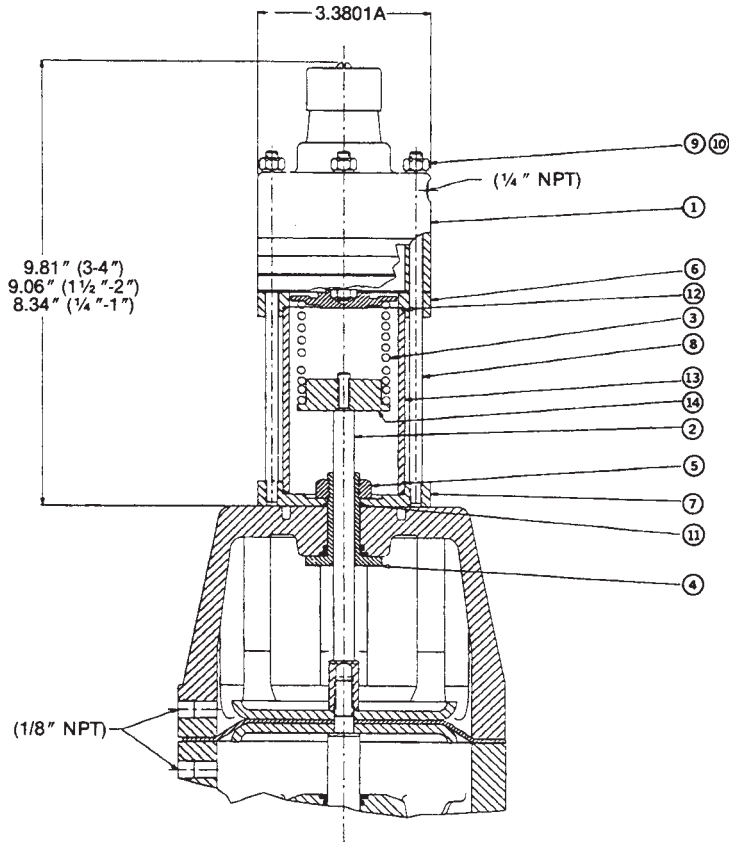

LIST OF PARTS			
ITEM	DESCRIPTION	MATERIAL	QTY.
1	POSITIONER-MOORE	ALUMINUM	1
2	SPINDLE, EXTENSION	STN. STL.	1
3	RANGE, SPRING	STEEL	1
4	GUIDE, SPINDLE $\frac{3}{4}$ - 2, 3" & 4" SERIES 33	BRASS	1
5	NUT, HEX JAM $\frac{1}{4}$ "-20 UNF ($\frac{3}{4}$ "-1"), 20-25)	STN. STL.	1
	NUT, HEX JAM $\frac{1}{4}$ "-18 UNF (1 1/2"-2, 40-50)	STN. STL.	1
	NUT, HEX JAM $\frac{1}{4}$ "-14 UNF (3" & 4" SERIES 33)	STN. STL.	1
	COLLAR-LOCKING (3-4", 80-100)	STN. STL.	1
6	PLATE, MOUNTING TOP	STN. STL.	1
7	PLATE, MOUNTING BOTTOM	STN. STL.	1
8	STUD	STN. STL.	6
9	NUT, HEX $\frac{1}{4}$ "-28 UNC	STN. STL.	6
10	WASHER, SPRINGLOCK $\frac{1}{4}$	STN. STL.	6
11	O RING, DASH NO. #112 ($\frac{3}{4}$ "-1", 20-25)	BUNA-N, FDA COMPLIANT	1
	O RING, DASH NO. #114 (1 1/2"-2", 40-50DN)	BUNA-N, FDA COMPLIANT	1
	O RING, DASH NO. #118 (3" & 4", SERIES 33)	BUNA-N, FDA COMPLIANT	1
	O RING, DASH NO. #225 (3-4", SERIES 47)	BUNA-N, FDA COMPLIANT	1
12	O RING, DASH NO #035	BUNA-N, FDA COMPLIANT STL.	2
13	TUBE-HOUSING	PVC., CLEAR	1
14	SEAT-SPRING	BRASS	1

*3-4" STANDARD SPINDLE

NOTE:

1. RECOMMENDED SPARE PARTS ARE MARKED WITH AN ASTERISK (*) ON THE LIST OF PARTS.

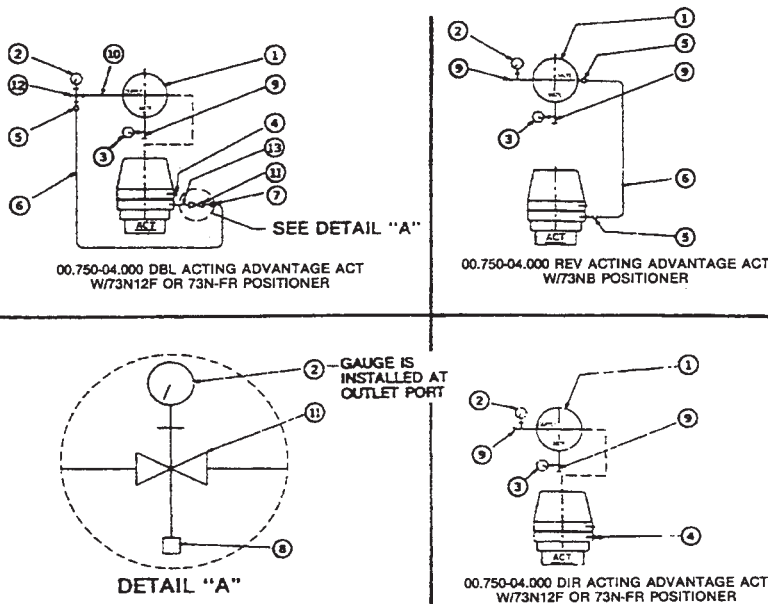

LIST OF PARTS			
ITEM	DESCRIPTION	MATERIAL	QTY.
1	POSITIONER-MOORE	ALUMINUM	1
2	GAUGE-PRESSURE 0-100 PSI	—	1
3	GAUGE-PRESSURE 0-30 PSI	—	1
4	PLUG-PIPE $\frac{1}{8}$ " NPT	STN. STL.	1
5	PLUG-PIPE $\frac{1}{8}$ " NPT	STEEL	1
6	CONNECTOR-MALE	STN. STL.	2
	CONNECTOR-MALE	BRASS	2
7	TUBING $\frac{3}{8}$ " OD STN. STL.	STN. STL.	AR
	TUBING $\frac{3}{8}$ " OD COPPER	COPPER	AR
8	ELBOW-MALE	STN. STL.	1
	ELBOW-MALE	BRASS	1
9	PLUG-PIPE $\frac{1}{4}$ " NPT	STEEL	1
	PLUG-PIPE $\frac{1}{4}$ " NPT STN. STL.	STN. STL.	1
10	TEE-STREET	STN. STL.	1
	TEE-STREET $\frac{1}{4}$ "	STEEL	1
11	NIPPLE-CLOSE $\frac{1}{4}$ " NPT	STEEL	1
	NIPPLE-CLOSE $\frac{1}{4}$ " NPT	STN. STL.	1
12	REGULATOR-CONOFLOW #GH04XSKED00-60	—	1
13	CROSS-FEMALE	STN. STL.	1
	CROSS-FEMALE $\frac{1}{4}$ "	STEEL	1
14	NIPPLE	STN. STL.	1
	NIPPLE	BRASS	1

NOTE:

1. FOR DIRECT & REVERSE ACTING ACT. ITEM #9. QUANTITY IS (2) TWO.
2. STN. STL. NATL. USED WHEN SPECIFIED ON ORDER.

FIGURE 5 VALVE DIAPHRAGM IDENTIFICATION

**ELASTOMER - 1 PIECE, MADE OF RUBBER, WITH
MOLDED IN STUD. (SEE TABS)**

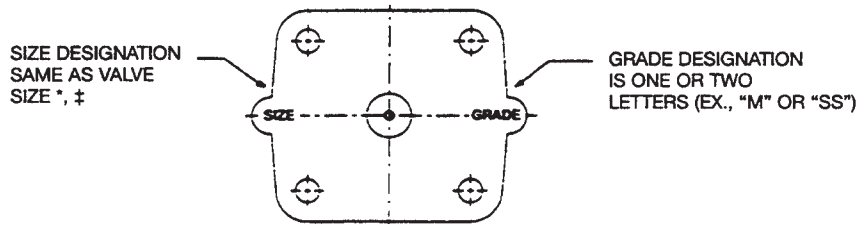

R2, TM (PTFE)
THESE DIAPHRAGMS ARE TWO-PIECE, WHITE PLASTIC
WITH A BLACK ELASTOMER BACKING.

* For 3/4" with flanged ends use 1" diaphragm except for solid plastic.

‡ For 1 1/4" solid plastic use 1 1/2" diaphragm.

**FIGURE 6
PLASTIC DIAPHRAGM DETAIL**

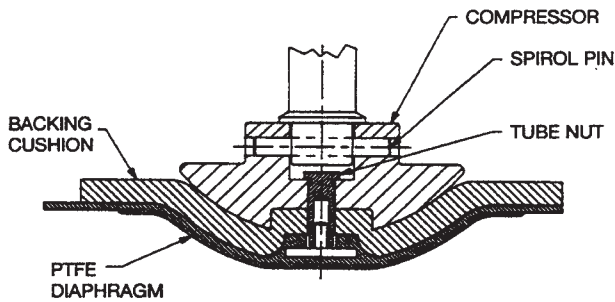
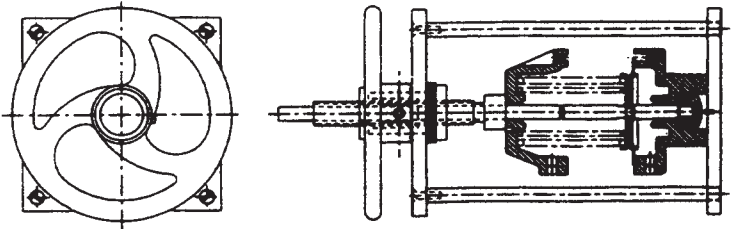

FIGURE 7



**TABLE 1
FASTENER TORQUES**

Body to Actuator

Valve Size		Bolt Size		PTFE ^R Diaphragm		Elastomer Diaphragm	
Inch	DIN	Inch	mm	in-lb	Joules	in-lb	Joules
Bio-Tek 1/4, 3/8, 1/2"	Bio-Tek 8, 10, 15	#6	3.51	20 in-lb	2.26	20 in-lb	2.26
1/2"	15	1/4"	6.35	50 in-lb	5.65	40 in-lb	4.52
3/4"	20	1/4"	6.35	60 in-lb	6.78	50 in-lb	5.65
1"	25	5/16"	7.94	100 in-lb	11.30	70 in-lb	7.91
1-1/2"	40	3/8"	9.52	200 in-lb	22.60	130 in-lb	14.69
2"	50	7/16"	11.11	250 in-lb	28.25	180 in-lb	20.34
3"	80	5/8"	15.87	750 in-lb	84.75	300 in-lb	33.90
4"	100	1/2"	12.70	575 in-lb	65.00	192 in-lb	21.70

**TABLE 1 (continued)
FASTENER TORQUES**

Actuator: Cover to Cover

Actuator Size		Bolt Size		Torque	
Inch	DIN	Inch	mm	in-lb	Joules
Bio (1/4)-1	8-25	#10	4.83	20	2.26
1-1/2" and 2"	40-50	1/4	6.35	35	3.95
3" and 4" (33)	80-100	5/16	7.94	120	13.56
3" and 4" (47)	80-100	3/8	9.52	120	13.56

**TABLE 2
ACTUATOR TRAVEL**

Size	Inch	Bio	1/2"	1/4"	1"	1 1/2"	2"	3"	4"
	DIN	Bio	15	20	25	40	50	80	100
Act YY#	AXYY	03	05	08	08	16	16	33,47	33,47
Valve Stroke	Inch	.16	.25	.38	.50	.81	1.12	1.62	1.62
	mm	4.06	6.35	9.65	12.70	20.57	28.45	41.15	41.15

ADVANTAGE ACTUATOR WEIGHTS

Weights are less body and diaphragm								
Size	Double Act		Direct		Reverse			
					60		90	
	lb	kg	lb	kg	lb	kg	lb	kg
Bio DIN 8, 10 15	0.99	0.45	1.05	0.48	1.09	0.49	1.11	0.50
0.50" DIN 15	1.61	0.73	1.70	0.77	1.82	0.83	1.95	0.88
0.75" DIN 20	2.72	1.23	2.81	1.28	3.14	1.42	3.37	1.53
1.00" DIN 25	3.00	1.36	3.11	1.41	3.45	1.56	3.68	1.67
1.50" DIN 40	8.50	3.86	9.00	4.08	10.66	4.84	12.84	5.82
2.00" DIN 50	9.17	4.16	9.67	4.39	11.33	5.14	13.51	6.13
3.00" (33) DIN 80	39.00	17.69	42.30	19.19	54.20	24.59	58.00	26.31
4.00" (33) DIN 100	44.00	19.96	47.30	21.46	59.20	26.85	63.00	28.58
3.00" (47) DIN 80	60.50	27.44	63.80	28.94	88.80	40.28	95.90*	43.5
4.00" (47) DIN 100	64.00	29.03	67.30	30.53	92.30	41.87	99.00*	44.91

*80 lb. Spring Package

TABLE 3
APPROXIMATE MAXIMUM CHAMBER VOLUME

Valve Size		Upper Chamber		Lower Chamber	
Inch	DIN	in ³	cm ³	in ³	cm ³
Bio-Tek ¼, ⅜ ½	Bio-Tek 8, 10, 15	2.62	43	2.26	37
.50*	15	5.49	90	4.27	70
0.75*	20	12.51	205	7.63	125
1.00*	25	12.08	198	9.15	150
1.50*	40	71.00	1163	34.78	570
2.00*	50	71.00	1163	38.75	635
3.00* (33)	80	247.80	4060	170.30	2790
4.00* (33)	100	247.80	4060	170.30	2790
3.00* (47)	80	463.80	7600	250.20	4100
4.00* (47)	100	463.80	7600	250.20	4100

TABLE 4
O RING CHART
ADVANTAGE ACTUATOR AND SWITCH PACKAGE, SP2

ACT SIZE AXYY	ACTUATOR UPPER COVER	ACTUATOR LOWER COVER	LOW PROFILE BUSHING	ACTUATOR CAP •	SP2 BASE •	SP2 ADAPTER/COVER •	SP2 UPPER COVER/ LOWER COVER
DWG. ITEM	13	7.9		14	10	12	13
03	#110	#110	#110, #112	N/A	#117	#116	#152
05	#112	#112	#112, #114	N/A	#117	#116	#152
08	#112	#112	#112, #114	N/A	#117	#116	#152
16	#114	#114	#114, #118	N/A	#117	#116	#152
*33	#208	#214	N/A	N/A	#117	#116	#152
*47	#212	#214	N/A	#128	#128	#116	#152

- 1) *FDA COMPLIANT BUNA N MATERIAL
2) STANDARD MATERIAL, UNLESS NOTED, IS FDA COMPLIANT VITON

NOTES

NOTES

Pure-Flo Solutions Group

OFFICE LOCATIONS

For more information, please contact:

Engineered Valves Headquarters

33 Centerville Road, P.O. Box 6164
Lancaster, PA 17603-2064 USA
or call: (800) 366-1111
(717) 509-2200

Fax: (717) 509-2336

Website: www.engvalves.com

E-mail: engvalves_custserv@fluids.ittind.com

**Pure-Flo Solutions Group
Headquarters**

33 Centerville Road
Lancaster, PA 17603
Phone 800-366-1111
Phone (717) 509-2200
Fax (717) 509-2336

**Pure-Flo California
Formerly ITT Sherotec**

725 East Cochran Street, Unit E
Simi Valley, CA 93065
Phone 800-926-8884
Phone (805) 520-7200
Fax (805) 520-7205

Pure-Flo Sweden

Formerly A.G. Johansons Metallfabrik

Box 26 Vasterasvagen 6
S-730 40 Kolbäck
Phone +46-220-403-20
Fax +46-220-405-23

Pure-Flo UK

Formerly Sinton Group

Richards Street
Kirkham, Lancashire
PR4 2HU, England
Phone +44-1772-682696
Fax +44-1772-686006

Pure-Flo



Free Manuals Download Website

<http://myh66.com>

<http://usermanuals.us>

<http://www.somanuals.com>

<http://www.4manuals.cc>

<http://www.manual-lib.com>

<http://www.404manual.com>

<http://www.luxmanual.com>

<http://aubethermostatmanual.com>

Golf course search by state

<http://golfingnear.com>

Email search by domain

<http://emailbydomain.com>

Auto manuals search

<http://auto.somanuals.com>

TV manuals search

<http://tv.somanuals.com>