

# TRANSITION

## Owner's Manual

Transition Recumbent Bike

### Customer Service

(800) 750-4766

Manufactured By:

**Ironman Fitness**

4009 Distribution Drive

Suite 250

Garland, TX 75041

### ⚠ CAUTION

Read all precautions and instructions in this manual before using this equipment.

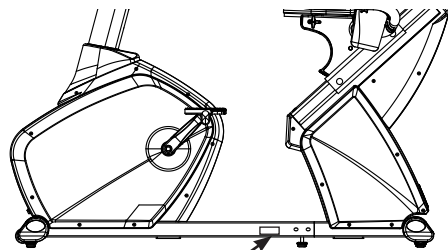

**Model Name : TRANSITION**

**Serial Number : \_\_\_\_\_**

*Serial Number can be found at the above specified location.*

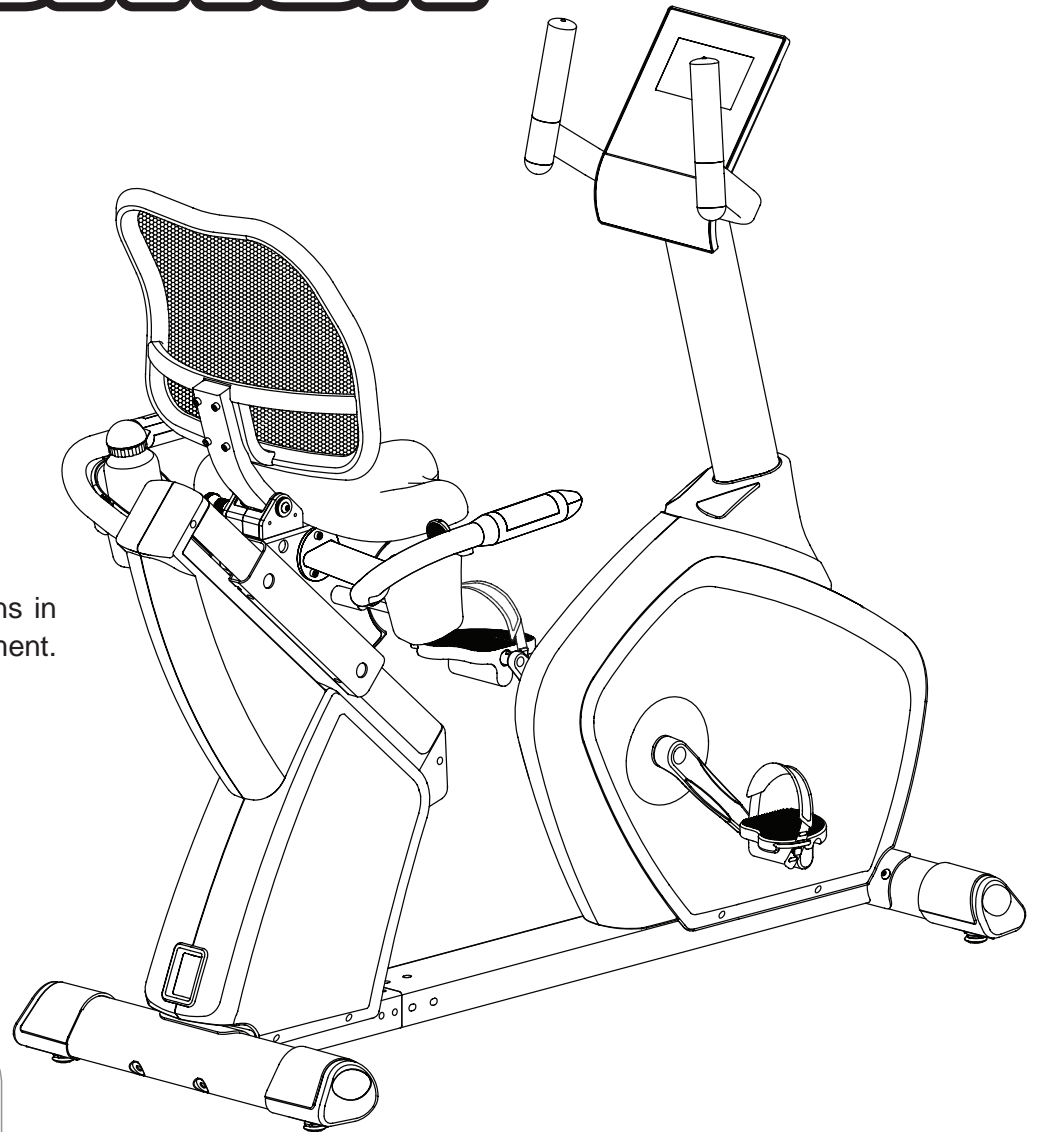

315-00137  
09/17 Rev 5.0

**TABLE OF CONTENTS**

Table of Contents	2
Important Safety Information	3
Assembly	4
Parts Identifier	5
Assembly Steps	7
Console Information	21
Workout Information	28
Parts List	32
Exploded View	34
Warranty	35

Ironman series  
MODEL: TRANSITION  
QUESTIONS?  
CALL

**(800) 750-4766**  
Monday-Friday  
8:30am - 5:30 pm Central Time

**THANK YOU**

**THANK YOU** for making this unit a part of your exercise program. Ironman Fitness assures the very best in value, appearance, durability and biomechanics.

This manual will guide you through the assembly process. If at any time you are having trouble with the assembly or use of this product, then please contact us at our Ironman Fitness Help line. We have trained service technicians on site to take care of you, our valued customer.

**REGISTRATION CARD**

To avoid unnecessary delays in warranty parts and to insure that a permanent record of your purchase is on file with our company, be sure to send in the warranty registration card or register on-line at [www.ironmanfitness.com](http://www.ironmanfitness.com) within 10 days of purchase..

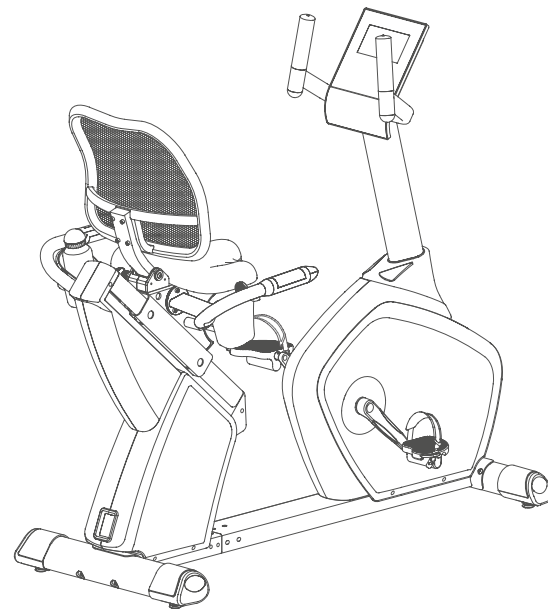

**WARNING!** Before using this unit or starting any exercise program, consult your physician. This is especially important for persons over the age of 35 and/or persons with pre-existing health problems. The manufacturer or distributor assumes no responsibility for personal injury or property damage sustained by or through the use of this product. To reduce the risk of electrical shock, burns, fire, or other possible injuries to the user, it is important to review this manual and the following precautions before operation.

## SAFETY PRECAUTIONS AND TIPS

1. It is the owner's responsibility to ensure that all users of this unit have read the Owner's Manual and are familiar with warnings and safety precautions.
2. This unit has a user maximum capacity of **300** pounds.
3. The unit should only be used on a level surface and is intended for indoor use only. The unit should not be placed in a garage, patio, or near water and should never be used while you are wet. Ironman Fitness recommends a mat be placed under the unit to protect floor or carpet and for easier cleaning.
4. Follow safety information in regards to plugging in your unit. Do not run the power cord underneath your unit. Do not operate the unit with a damaged or frayed power cord.
5. Wear comfortable, good-quality walking or running shoes and appropriate clothing. Do not use the unit with bare feet, sandals, socks or stockings.
6. Always examine your unit before using to ensure all parts are in working order.
7. Allow the unit to fully stop before dismounting.
8. Pets should never be allowed near the unit.
9. Do not leave children unsupervised near or on the unit.
10. Never operate the unit where oxygen is being administered, or where aerosol products are being used.
11. Never insert any object or body parts into any opening.
12. For safety and to prevent damage to your unit, no more than one person should use the unit at a time.
13. Always unplug the unit before cleaning and/or servicing. Service to your unit should only be performed by an authorized service representative, unless authorized and/or instructed by the manufacturer.
14. Failure to follow these instructions will void the unit warranty.

Thank you for purchasing the Ironman Fitness **Transition!** The quality product you have chosen was designed to meet your needs for cardiovascular exercise. Before you start, please read the Owner's Manual and become familiar with the operation of your new unit. Remember to take time to perform stretching exercises, provided in this manual, to help avoid injury. If you are taking medication, consult your physician to see what effect the medication will have on your exercise heart rate. If you have heart problems, you are not active, and/or are over the age of 35 years, do not use the pre-set programs or start an exercise program without first contacting and receiving approval from your physician. To avoid the risk of electrical shock, always keep the console dry. Do not spill liquids on the console. Ironman Fitness recommends a sealed water bottle for beverages consumed while using the unit.

**IRONMAN** **Assembly**  
*Fitness* [www.ironmanfitness.com](http://www.ironmanfitness.com)



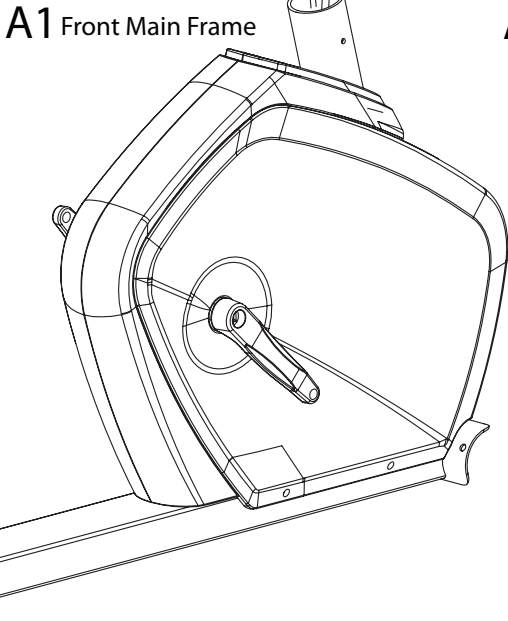
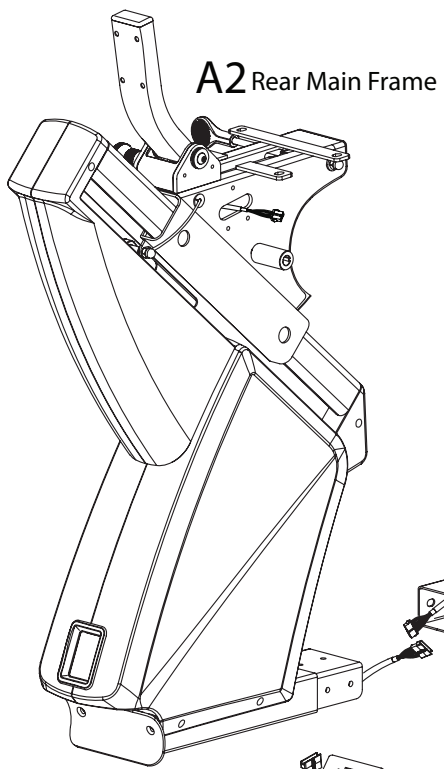

A11 Seat Slide Adjustment Handle

B Front Stabilizer

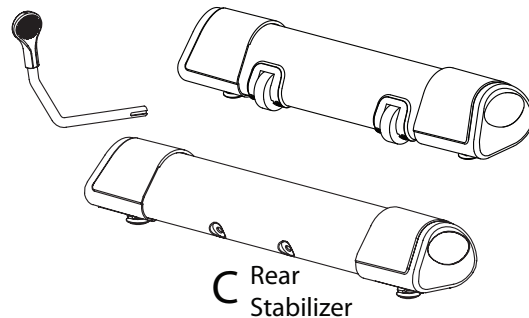

G Seat Pad



F Console

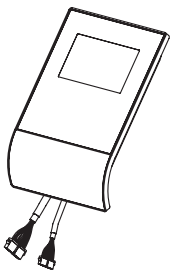

E Upright Handlebar

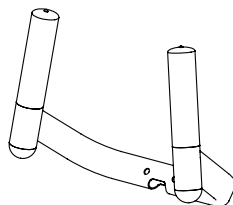

D Upright Post

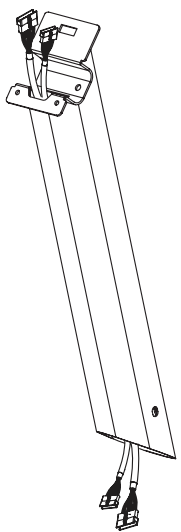

H Back Rest

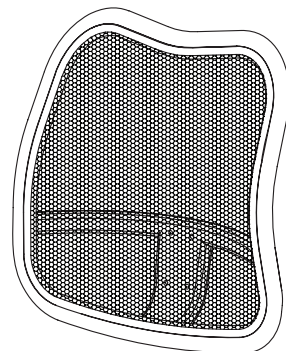

 Prior to assembly, remove components from the box and verify that all the listed parts were supplied.

I Upright Post Cover

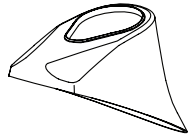

J-L Side Handlebar - Left

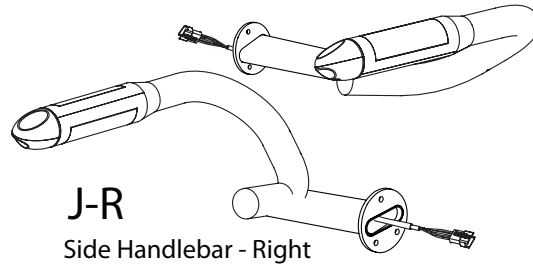

J-R Side Handlebar - Right

K Water Bottle



L-L Pedal - Left

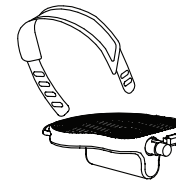

L-R Pedal - Right

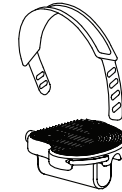

M Adapter

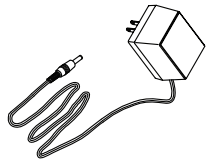

N1 Allen Screws M8\*15



N2 Spring Washers M8



N3 Flat Washers M8

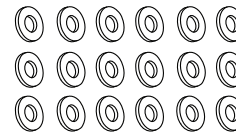

N4 Allen Screws M8\*105

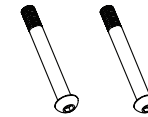

N5 Allen Screws 1/4" \*40



N6 Allen Screws M6\*12



N7 Allen Screws M8\*20



N8 Screws M4\*15



N9 Allen Screws (Black) M8\*35



N10 Set Screw M6\*8



N11 Flat Washers (Black) M8



N12 Oval Washers 8\*4.5



R1 Accessory Tray - Left

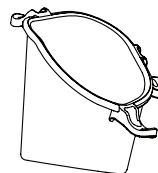

R2 Accessory Tray - Right

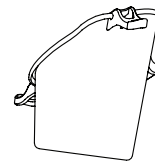

Tools

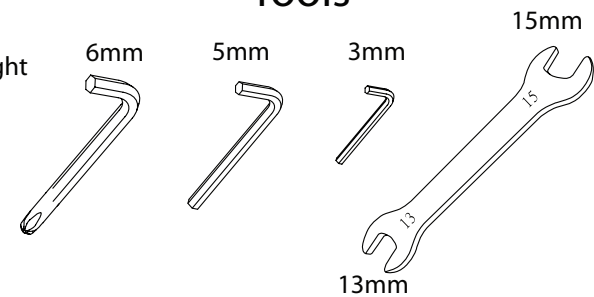

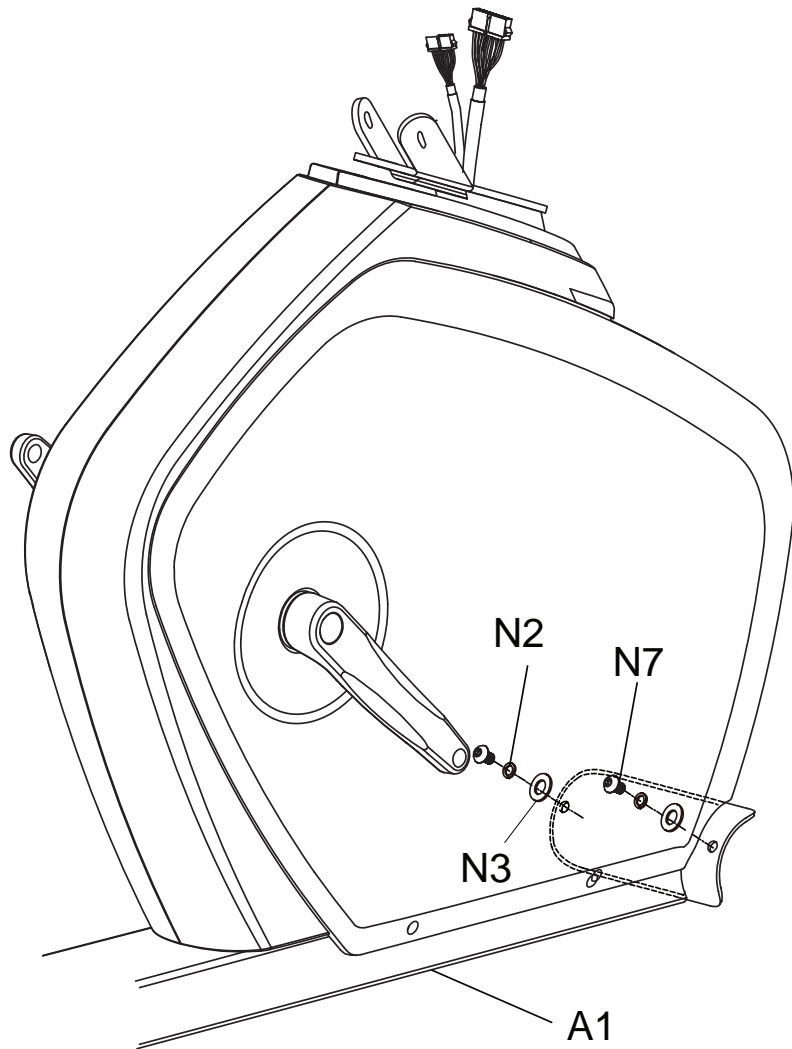

# 1

## ASSEMBLY FOR FRONT STABILIZER

Secure the front stabilizer (B) to the front main frame (A1) using 2 screws (N7), 2 spring washers (N2) and 2 flat washers (N3).

 **Note:** Front stabilizer (B) is very similar to rear stabilizer (C) but contains transport wheels. Make sure not to get them mixed up.

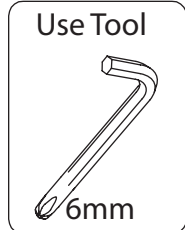
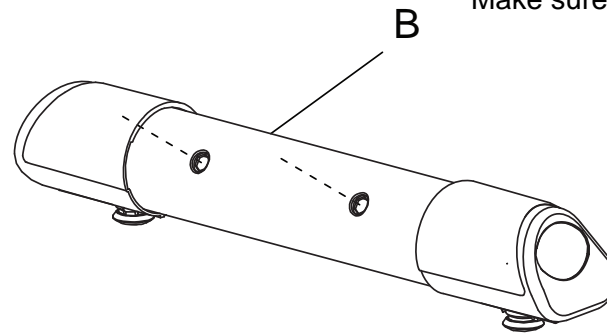

# 2

## ASSEMBLY FOR REAR STABILIZER

Secure the rear stabilizer (C) to the rear main frame (A2) using two screws (N4), 2 spring washers (N2) and 2 flat washers (N3).



**Note:**

After you finish the assembly for front and rear stabilizer bars in order to add stability to the unit, you may need to adjust the levelers that are located on the bottom of the unit.

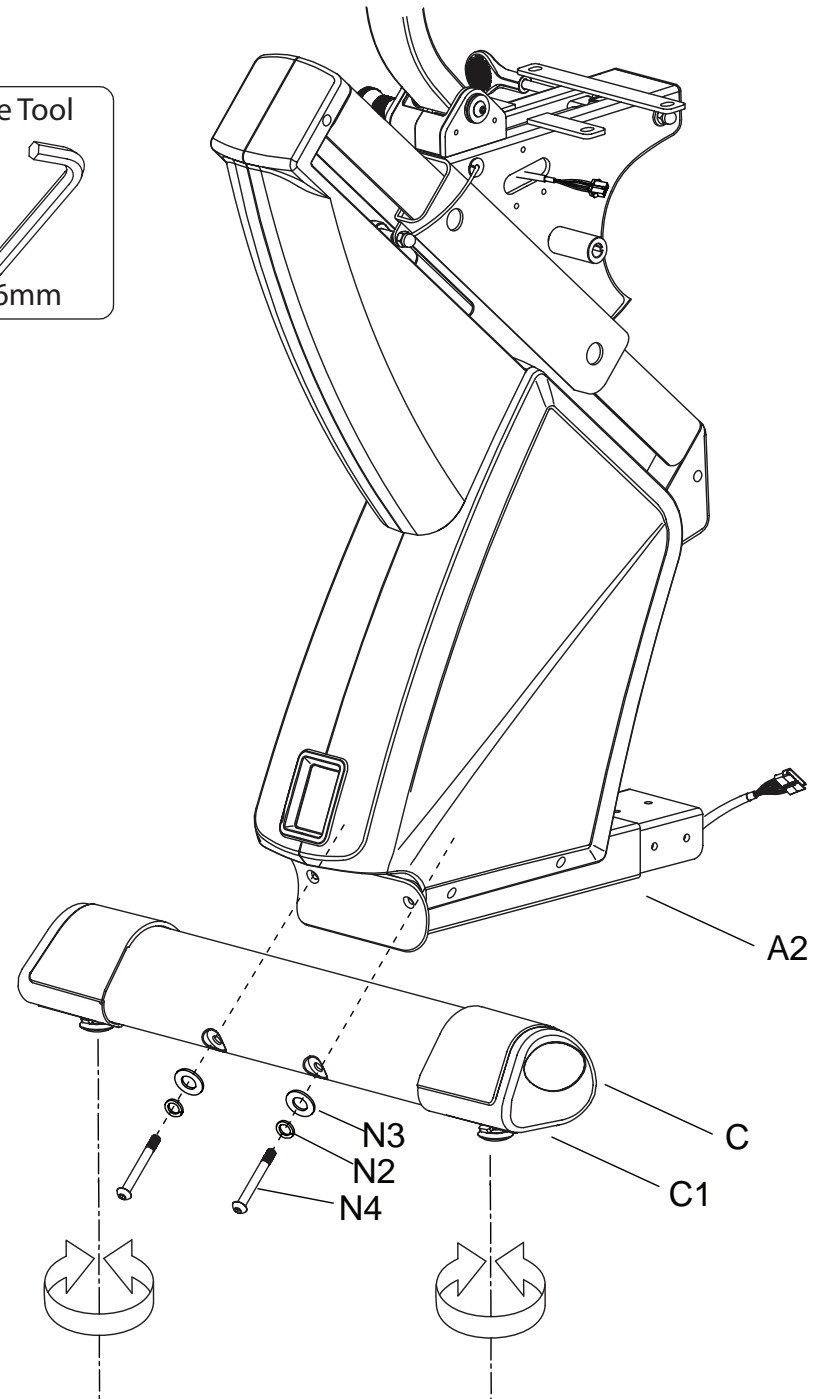
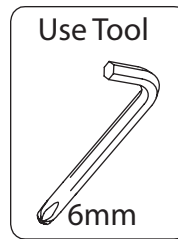



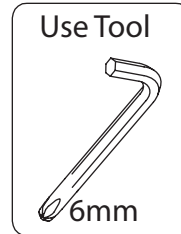
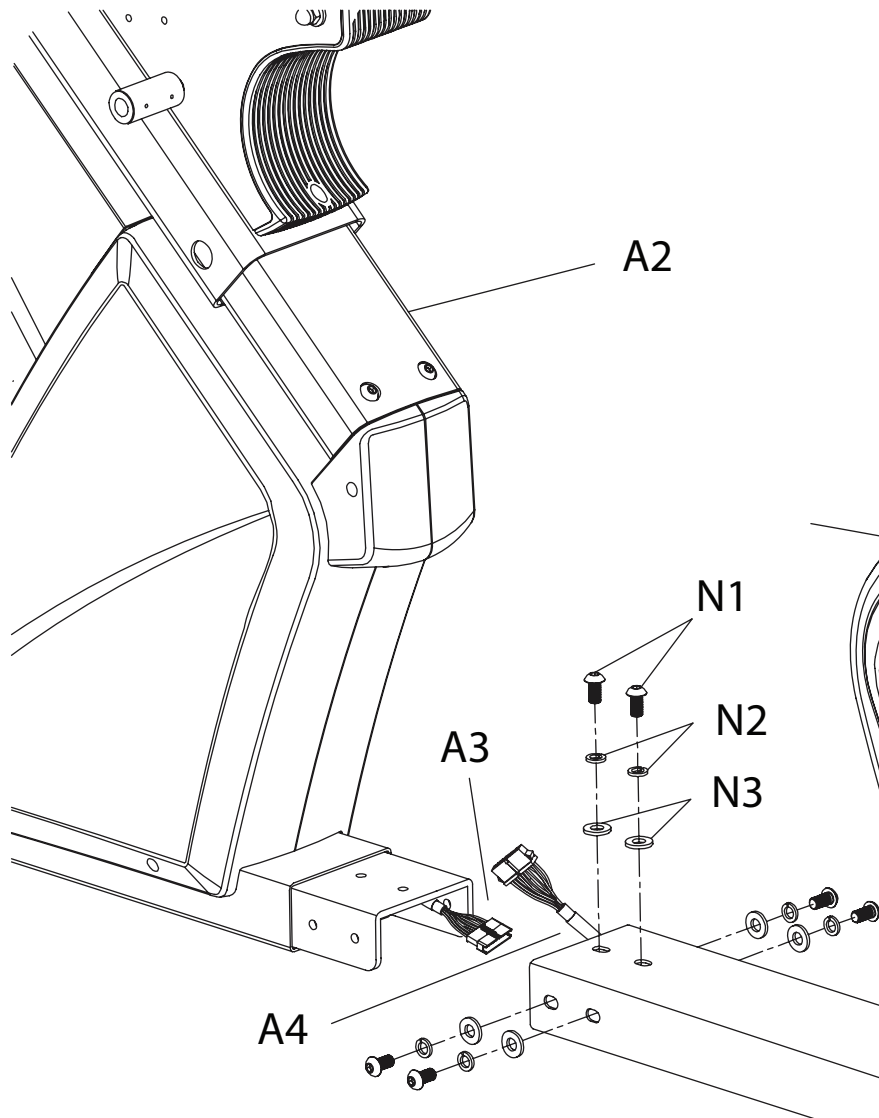

# 3

## ASSEMBLY FOR FRONT & REAR MAIN FRAME

### Step 1:

Connect the front (A4) and rear (A3) pulse wires together.

### Step 2:

Attach front (A1) and rear (A2) main frames together, making sure all wires are lined up correctly so that they are not pinched when assembling the two frames together. Then, secure them using 6 allen screws (N1), 6 spring washers (N2) and 6 flat washers (N3).

# 4

## ASSEMBLY FOR UPRIGHT POST

### Step 1:

Insert the upright post cover (I) to the upright post (D) from the bottom side.

### Step 2:

Connect the lower pulse wire (A4) with the upper pulse wire (A33). Also, connect the lower sensor wire (A36) with the upper sensor wire (A34).

### Step 3:

Attach upright post (D) to the front main frame (A1). Secure with 4 allen screws (N1), 4 spring washers (N2) and 4 flat washers (N3).

### Step 4:

Slide the upright tube cover (D) down to conceal tube connection.



### Note:

Be careful not to pinch the sensor wire connection during assembly.

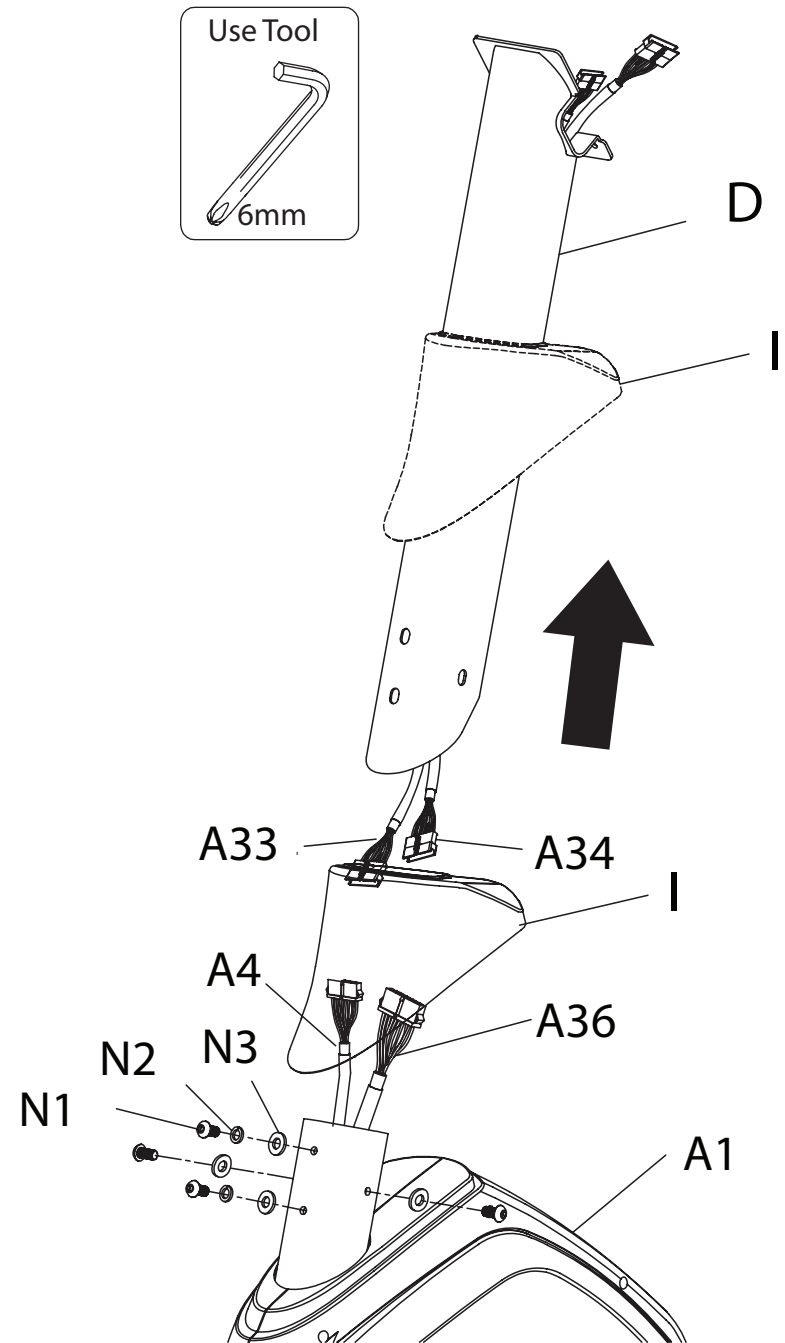

# 5

## ASSEMBLY FOR SEAT SLIDE ADJUSTMENT

Insert the seat slide adjustment handle (A11) into the seat slide adjustment collar on the seat slide assembly (A9). Secure it with M6 set screw (N10).

## ASSEMBLY FOR RIGHT HANDLEBAR

### Step 1:

Connect pulse wire (J1) and pulse wire (A3).

### Step 2:

Mount the right handlebar (J-R), to the seat slide assembly (A9) and secure with 3 allen screws (N6).

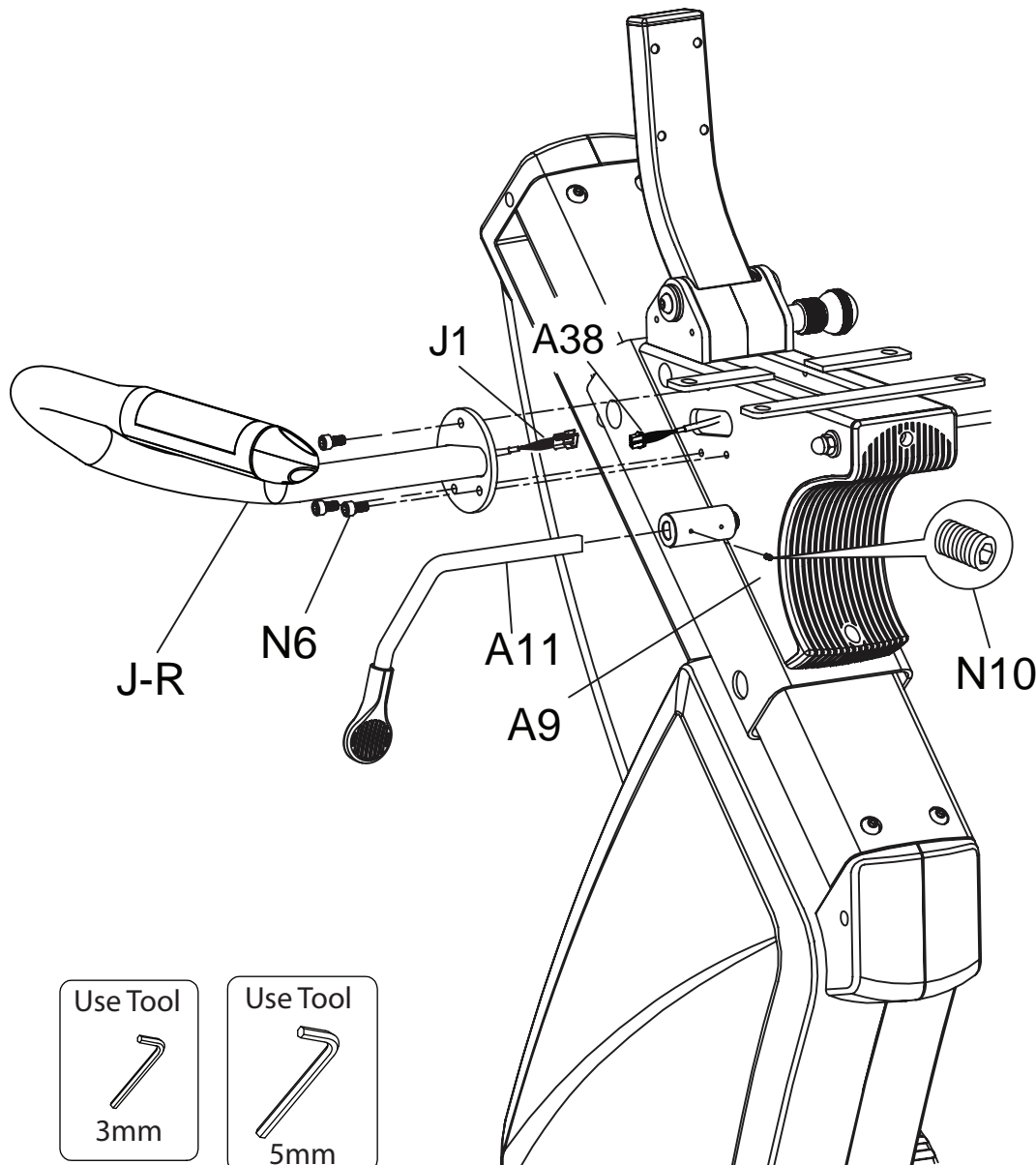

# 6

## ASSEMBLY FOR SEAT CUSHION

Attach seat (G) to the seat slide assembly (A9) using allen screws (N1) and flat washers (N3).

## ASSEMBLY FOR LEFT HANDLEBAR

### Step 1:

Connect pulse wire (J2) and pulse wire (A3).

### Step 2:

Mount the right handlebar (J-L), to the seat slide assembly (A9) and secure with 3 allen screws (N6).

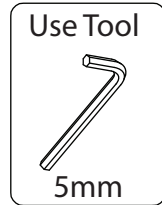
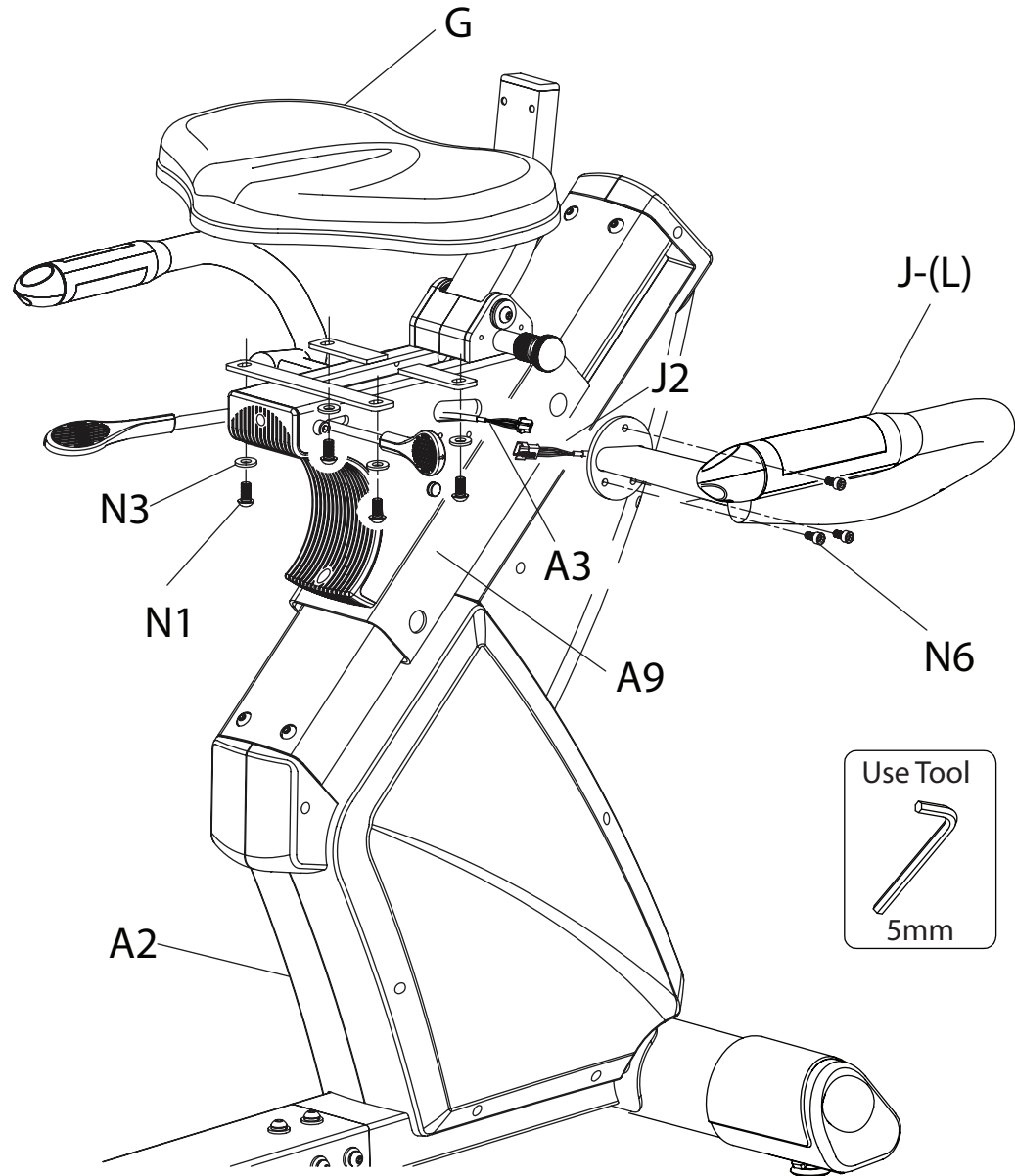

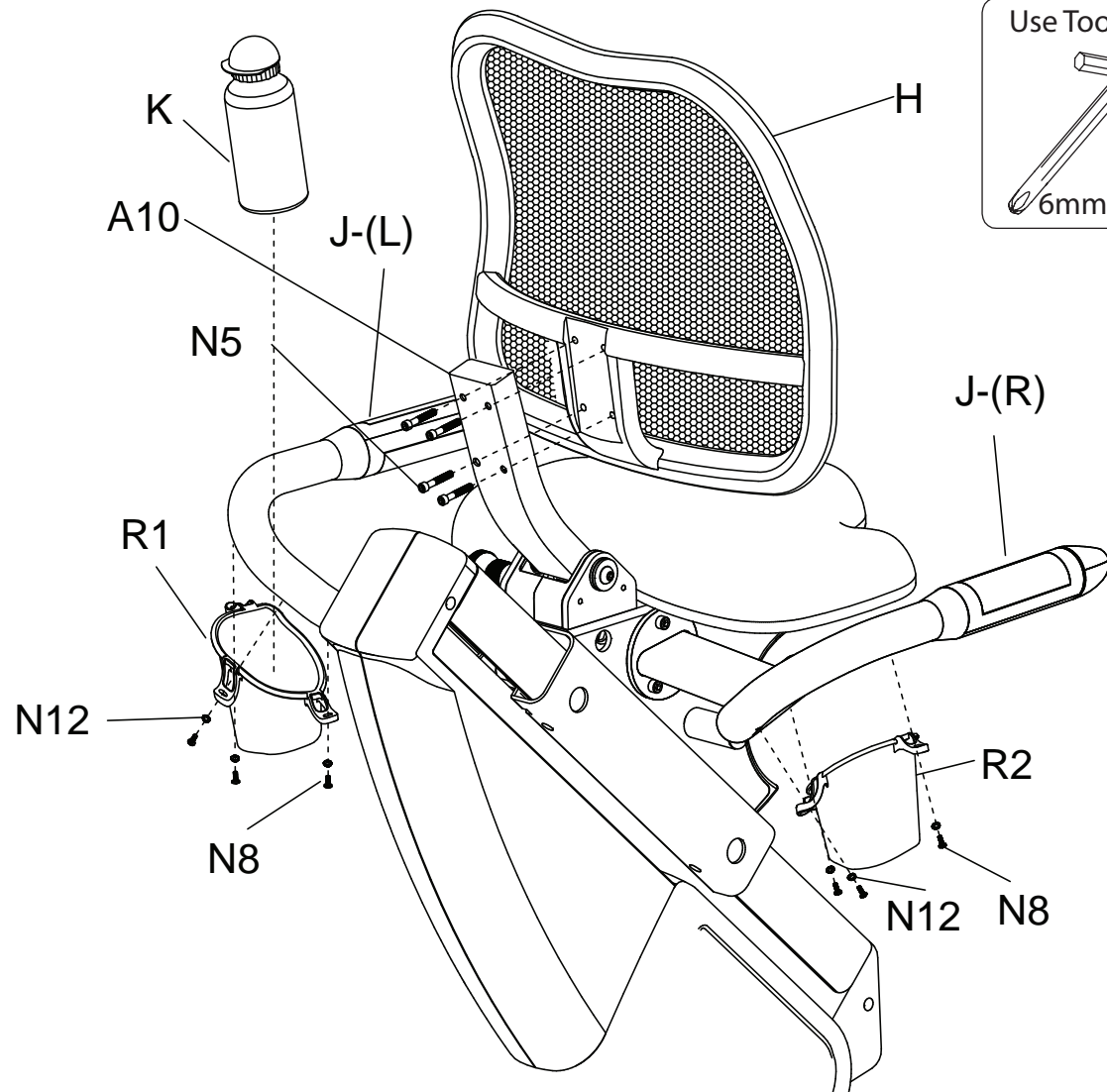

# 7

## ASSEMBLY FOR BACK REST

### Step 1:

Attach the back rest (H) to the seat support tube (A10) and secure it using 4 allen screws (N5).

## ASSEMBLY FOR ACCESSORY TRAYS

### Step 1:

Attach the right accessory tray (R2) to the side handlebar - right (J-R) and secure using 3 screws (N8) and 3 oval washers (N12).

### Step 2:

Repeat step 1 with left accessory tray (R1).

### Step 3:

Place water bottle (K) in one of the accessory trays.

# 8

## ASSEMBLY FOR UPRIGHT HANDLEBAR

Attach the handlebar (E) to the upright post (D) and secure it with 2 allen screws (N9) and 2 flat washers (N11).

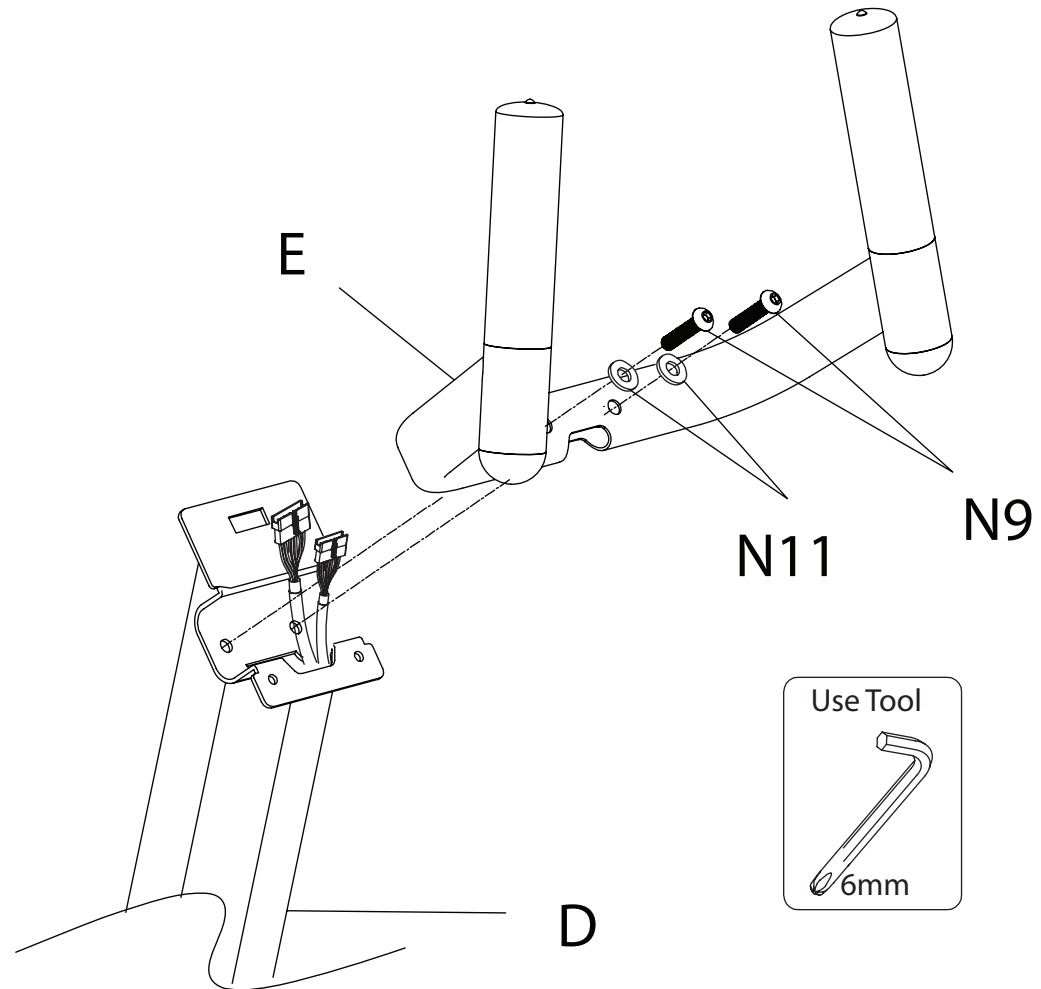

# 9

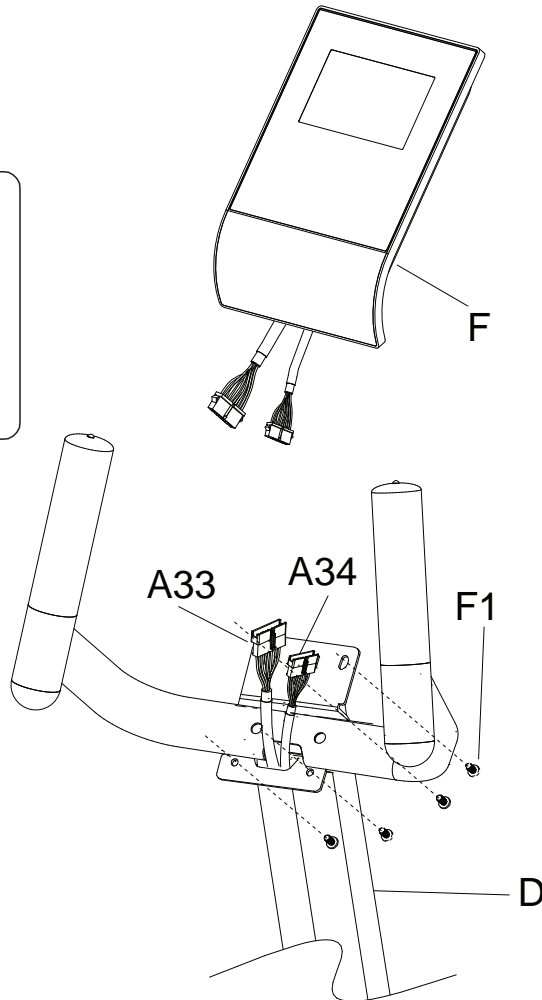
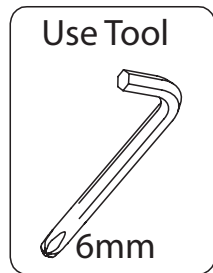

## ASSEMBLY FOR CONSOLE

### Step 1:

Connect the sensor wire (A34) and the pulse wire (A33) with the corresponding wires on the console (F).

### Step 2:

Gently push all wires into the upright post and mount the console (F) onto the console mounting plate at the top of the upright tube (D). Secure with screws (F1) to keep the console in place.



### Note:

Screws (F1) will already be attached on the backside of the console. Remove before sliding onto console tube.

# 10

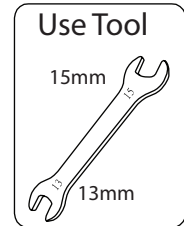

## ASSEMBLY FOR PEDALS

### Step 1:

Attach left pedal strap (L1) to left pedal (L-L) and right pedal strap (L2) to right pedal (L-R).

### Step 2:

Thread the left pedal (L-L) into the pedal crankshaft in the **counter-clockwise** direction.

### Step 3:

Thread the right pedal (L-R) into the pedal crankshaft in the **clockwise** direction.

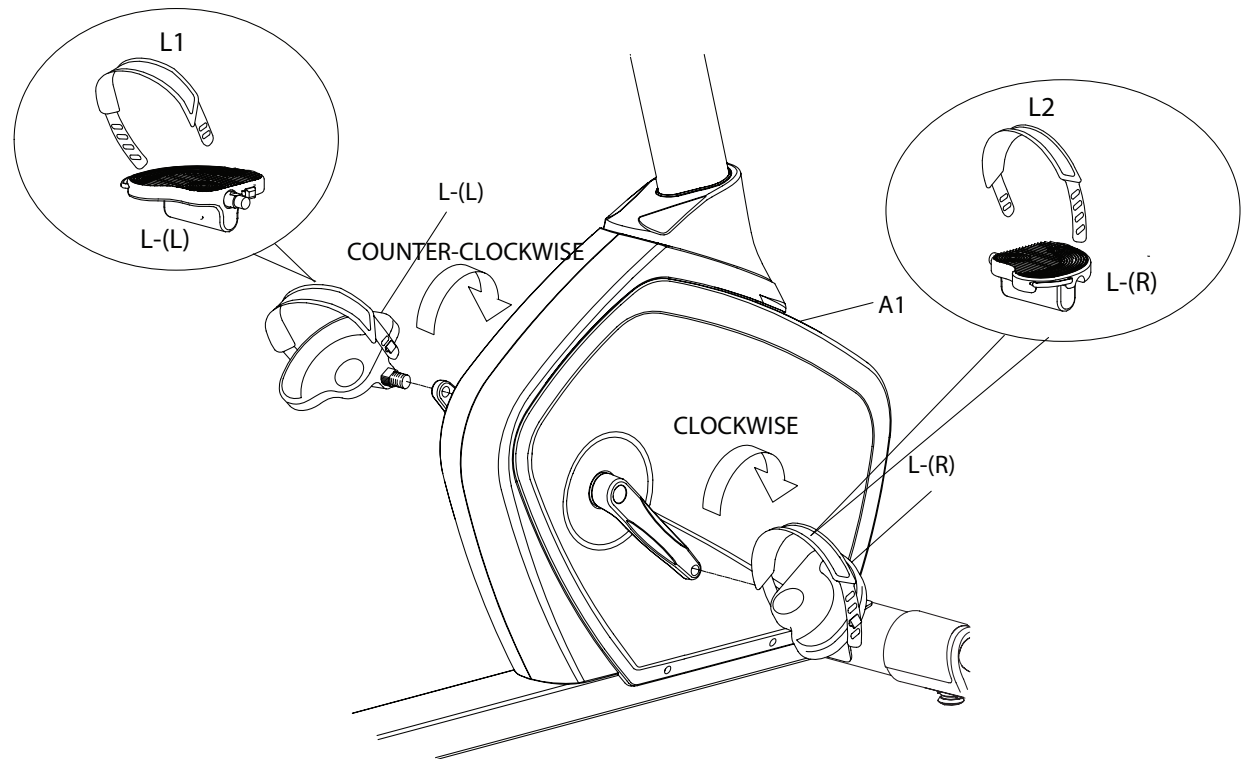



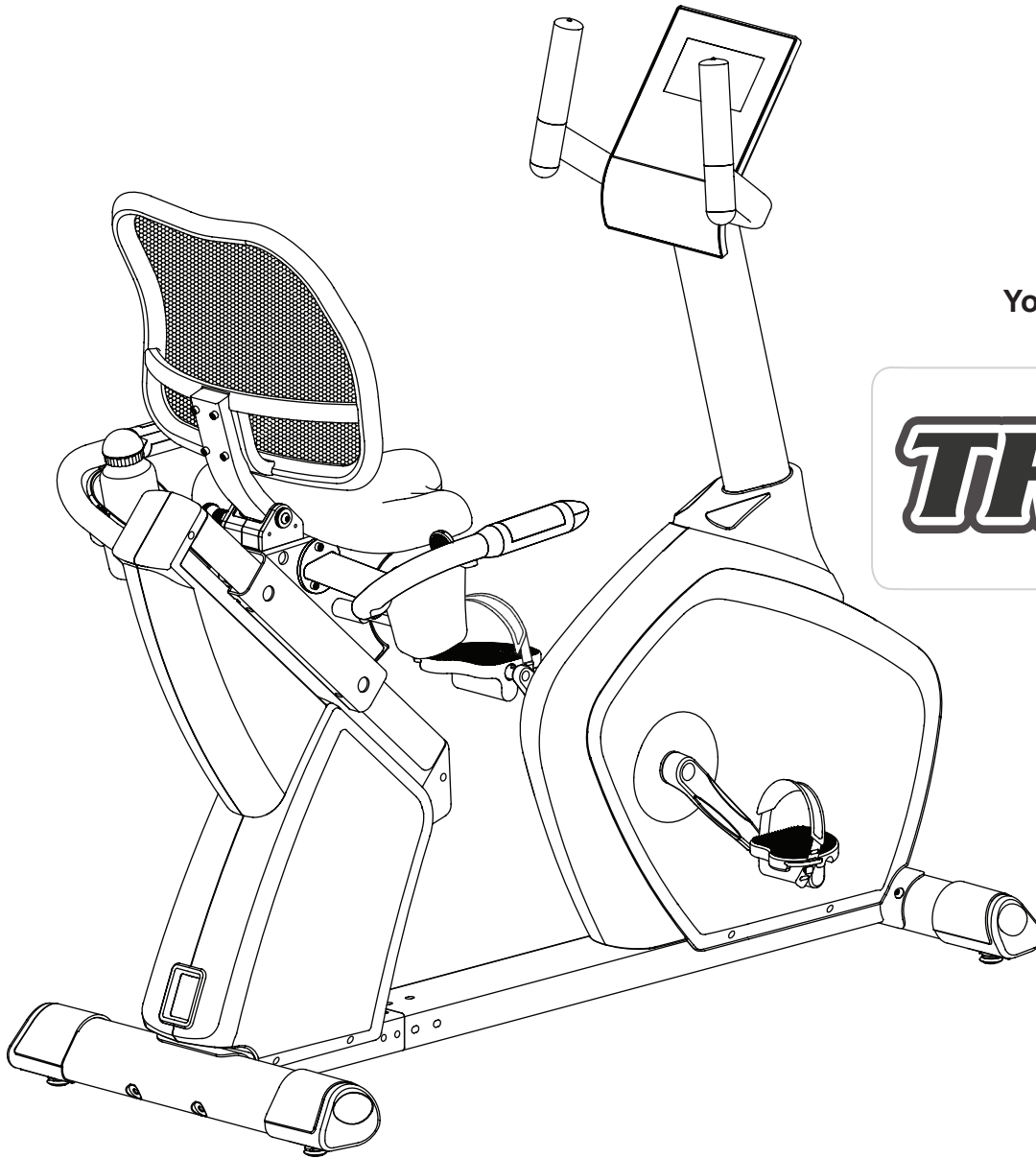

**Congratulations!**  
You have completed the assembly of your new  
Ironman Transition Recumbent Bike!

**TRANSITION**

**ADJUSTING YOUR BACK REST POSITION**

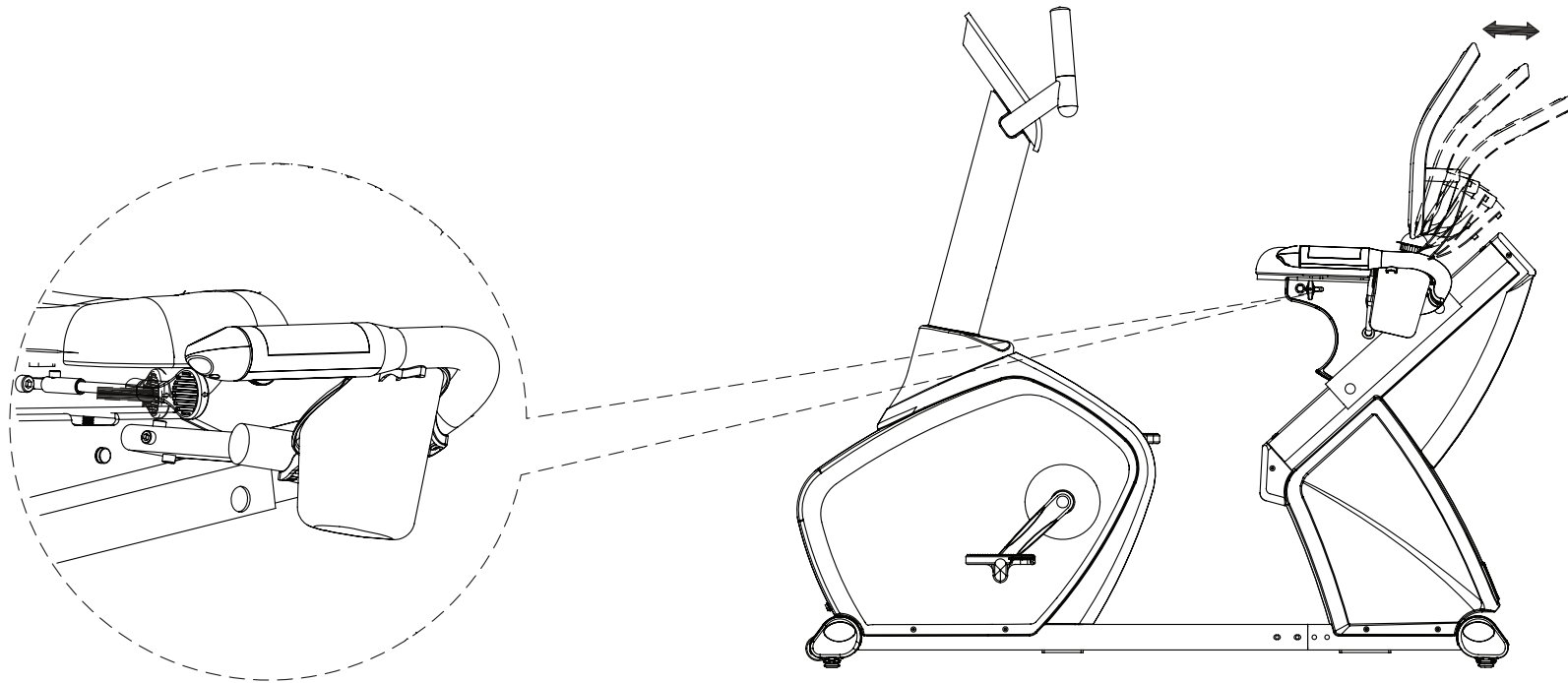

### ADJUSTING YOUR SEAT POSITION

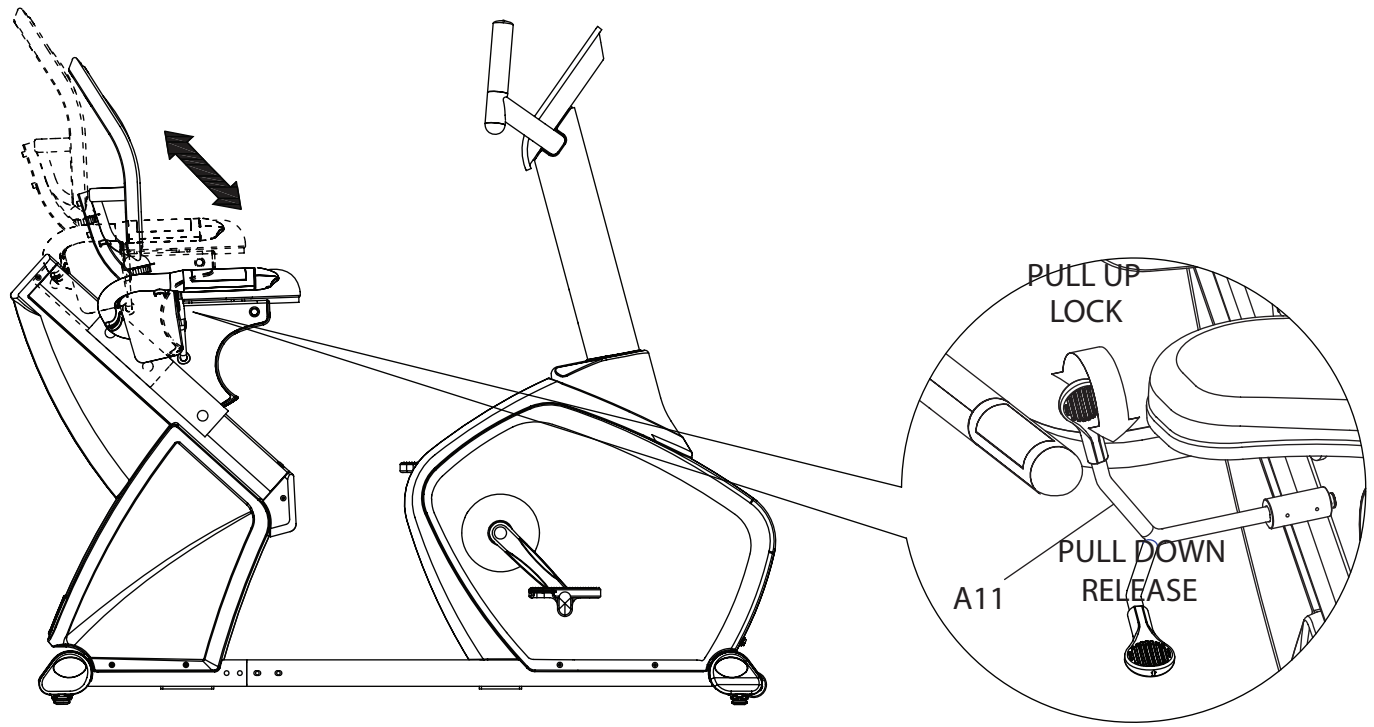

### ADAPTER PLUG-IN LOCATION

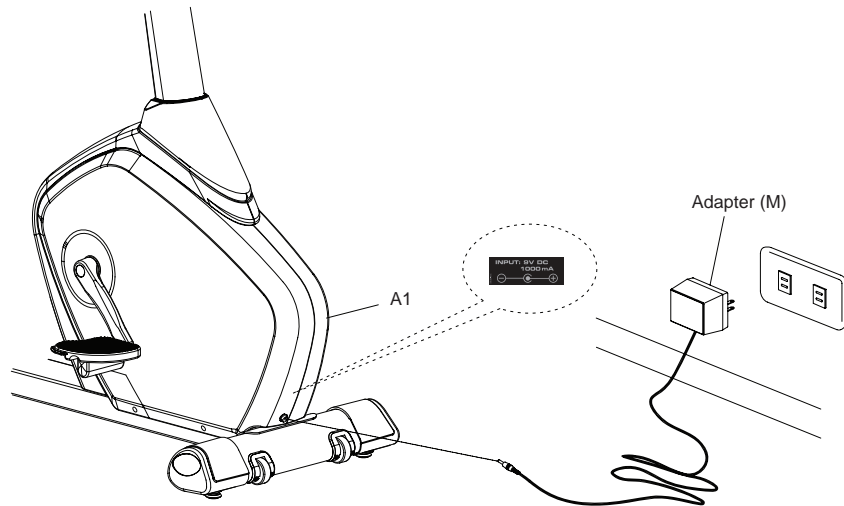

### TRANSPORTING YOUR UNIT

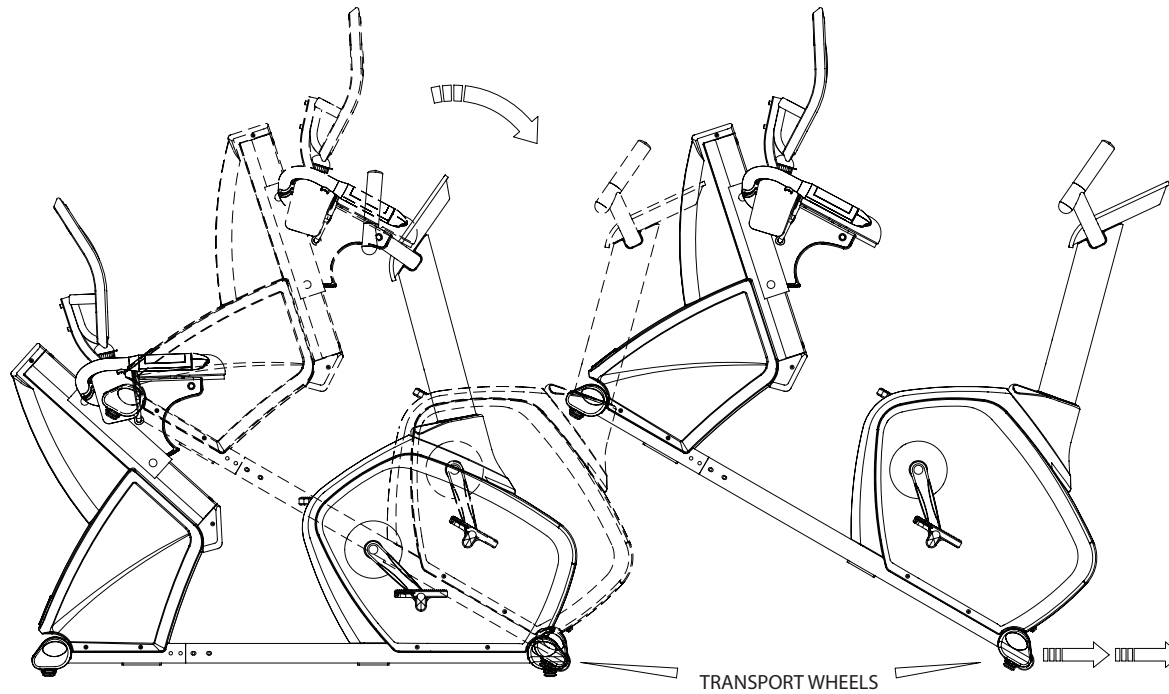

**IRONMAN**  
*Fitness* **Console Information**  
[www.ironmanfitness.com](http://www.ironmanfitness.com)



## CONSOLE BUTTONS:

### **UP/DOWN:**

These buttons are used to change programs and settings.

### **ENTER:**

This button is used as an entry key, which will allow user to confirm settings such as time, distance and calories.

### **RECOVERY:**

This button is used to begin the Recovery feature of the console (refer to Console Function section for more information).

### **CLEAR:**

This button will revert the console back to the program selection menu.

### **RESET:**

This button is used to return to main menu screen when workout is paused. It is also used to reset all values to zero.

### **START/STOP:**

This button is used to start or stop training

**NOTE:** *Only buttons pertinent to current selection will light up (buttons only light up when they can be used).*

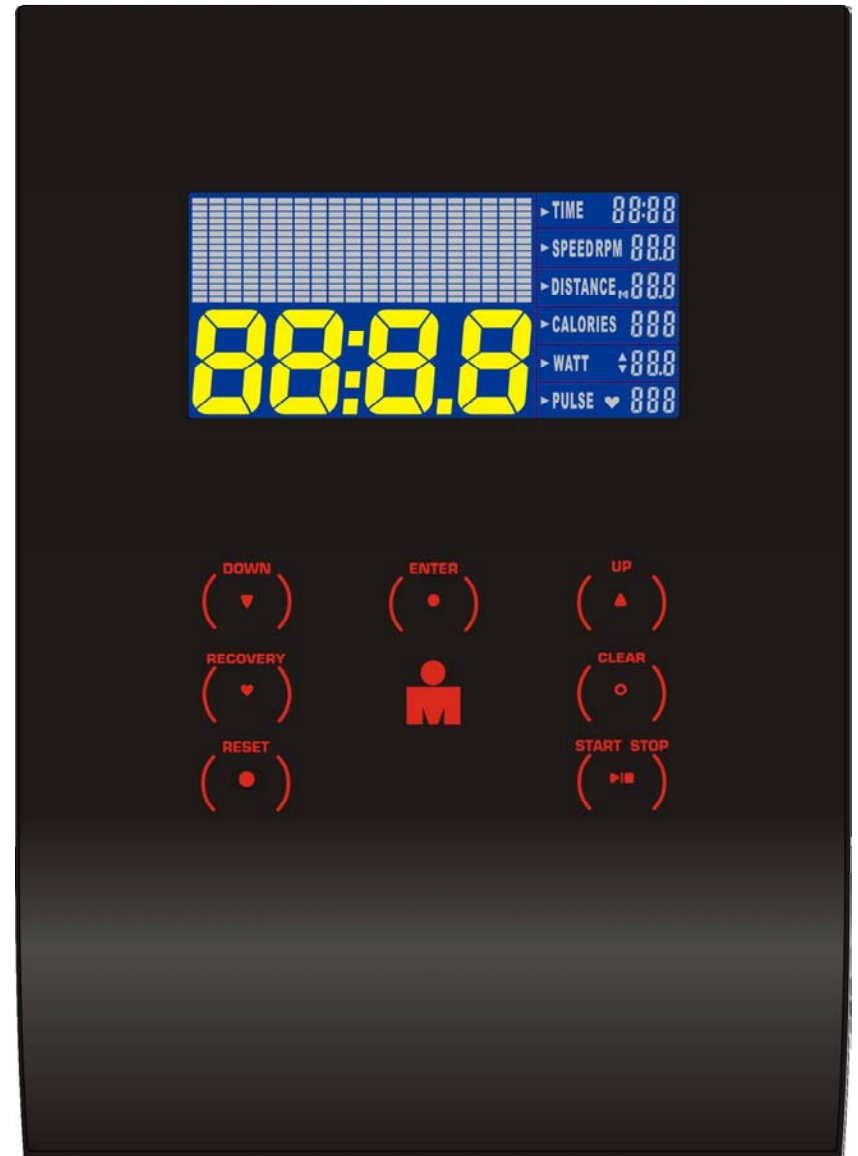

## **CONSOLE FUNCTIONS:**

### **TIME:**

If a target time was not selected, time will count up from 00:00 to maximum 99:59. When working out with a target time, time will count down from target to 00:00. When selecting target time, use the +/- buttons, the time will change in 1 minute increments and can range from 1:00 min to 99:00 mins.

### **SPEED:**

Displays current training speed from 0.0 to maximum 99.9 KM or MPH.

### **RPM:**

Displays current training revolutions per minute.

### **DISTANCE:**

If a target distance was not selected, distance will count up from 0.00 to maximum 99.90. When working out with a target distance, distance will count down from target to 0.0. When selecting target time, use the +/- buttons, the distance will change in 0.1 mile increments and can range from 0.00 miles to 99.90 miles.

### **CALORIES:**

If target calories were not selected, calories will count up from 0 to maximum 990. When working out with target calories, calories will count down from target to 0. When selecting target calories, use the +/- buttons, the calories will change in 10 calorie increments and can range from 0 calories to 990 calories.

### **PULSE:**

Displays your current heart rate as soon as both hands are holding the pulse sensor. The monitor will detect your heart rate through hand grip sensors that are located on the handlebar. The pulse value can be set during program setup. During workout, if your actual pulse rate exceeds the preset value the console will make a double beep sound. **Note:** *It may take several seconds for the electronics to detect and display a heart rate reading.*

### **WATT:**

Displays current training watt figures. A watt is a measurement of the amount of power generated by the user based on the resistance and speed.



**RECOVERY:**

After your workout, keep holding on hand grips and press “RECOVERY” button. All function display will stop except “TIME” starts counting down from 00:60 to 00:00. Screen will display your heart rate recovery status rating between F1-F6. F1 is the best, F6 is the worst. User may keep exercising to improve the heart rate recovery status. (Press the RECOVERY button again to return the main display.)

**CALENDAR:**

Screen will display year/month/day in sleep mode. When the unit is plugged in the console will prompt user to input correct information. Use the UP and DOWN button until correct year is found. Press ENTER to confirm selection. Repeat steps to input correct month followed by the correct date.

*Note: All information will be saved until unit is unplugged.*

**CLOCK:**

Screen will display time in sleep mode. Once the calendar is set, you will be able to input the correct time. Use the UP and DOWN buttons until the correct hour is found. Press ENTER to confirm selection. Repeat steps to input correct minutes. *Note: All information will be saved until unit is unplugged. Note: Clock will only display 24 hour time.*

**TEMPERATURE:**

Screen will display room temperature in sleep mode.

**GENERAL INFORMATION:**

1. Start Pedaling or press any button to start Console.
2. The Console will shut down after 4 minutes of no activity, and will display room temperature.
3. To Reset Console press Reset button.

Score	Condition	Heart Rate ( from test HR minus end HR)
F1	<b>Excellent</b>	Above 50
F2	<b>Good</b>	40 ~ 49
F3	<b>Average</b>	30 ~ 39
F4	<b>Fair</b>	20 ~ 29
F5	<b>Poor</b>	10 ~ 19
F6	<b>Very Poor</b>	Under 10

*Note: The values calculated or measured by the console are for exercise purposes only, not for medical purposes.*

**PROGRAM INSTRUCTIONS:**

**MANUAL PROGRAM:**

Allows the User to manually adjust tension settings throughout their workout. You may set Time or Distance for your workout. Use the UP/DOWN buttons to scroll to this program. Press ENTER to select this program. The resistance level L01 will flash. Use the Up (▲) or Down (▼) button to select your desired resistance. The press ENTER to select. TIME will flash in the display. Use the UP/DOWN keys to set desired TIME. Press ENTER to confirm value. Repeat steps for DISTANCE, KCAL, and PULSE. Press START/STOP to begin exercising. Grasp Pulse Grips loosely with both hands to activate PULSE function. You can change the tension level at any time during your workout session by pressing the UP/DOWN



buttons.

### PRESET PROGRAMS:

Each Program is divided into ten segments. Use the UP/DOWN buttons to scroll to this program. Press MODE/ENTER to select this program. TIME will flash in the display. Use the UP/DOWN keys to set desired TIME. Press MODE/ENTER to confirm value. Repeat steps for DISTANCE and KCAL. Press START/STOP to begin exercising. Grasp Pulse Grips loosely with both hands to activate PULSE function.

### WATT PROGRAM:

In this program, the WATT function will keep a constant value. This means that if you pedal quickly, the tension will decrease, if you pedal slowly the tension will increase to maintain the Watt value entered.

Use the UP/DOWN buttons to scroll to this program. Press MODE/ENTER to select this program. WATT will flash in the display. Use the UP/DOWN keys to set desired WATT. Press

MODE/ENTER to confirm value. Repeat steps for TIME, DISTANCE, KCAL and PULSE. Press START/STOP to begin exercising. Grasp Pulse Grips loosely with both hands to activate PULSE function.

### CHANGING BETWEEN METRIC (KILOMETERS) AND STANDARD (MILES):

To switch the console from Miles to Kilometers you first press RESET on the console. Next, **LIGHTLY** press and hold the ENTER button followed by pressing and holding the CLEAR button. This should bring up the letters ODO in main window. (M should flash in the distance window) Use the Up (▲) and Down (▼) buttons to change the console from (M) to (K). Then, press the ENTER button. Next, the F should flash in the calories window. Use the Up (▲) and Down (▼) areas to change F to C. Then, press the ENTER button. The console will reset. **Note:** Time and calendar will be reset to factory defaults.

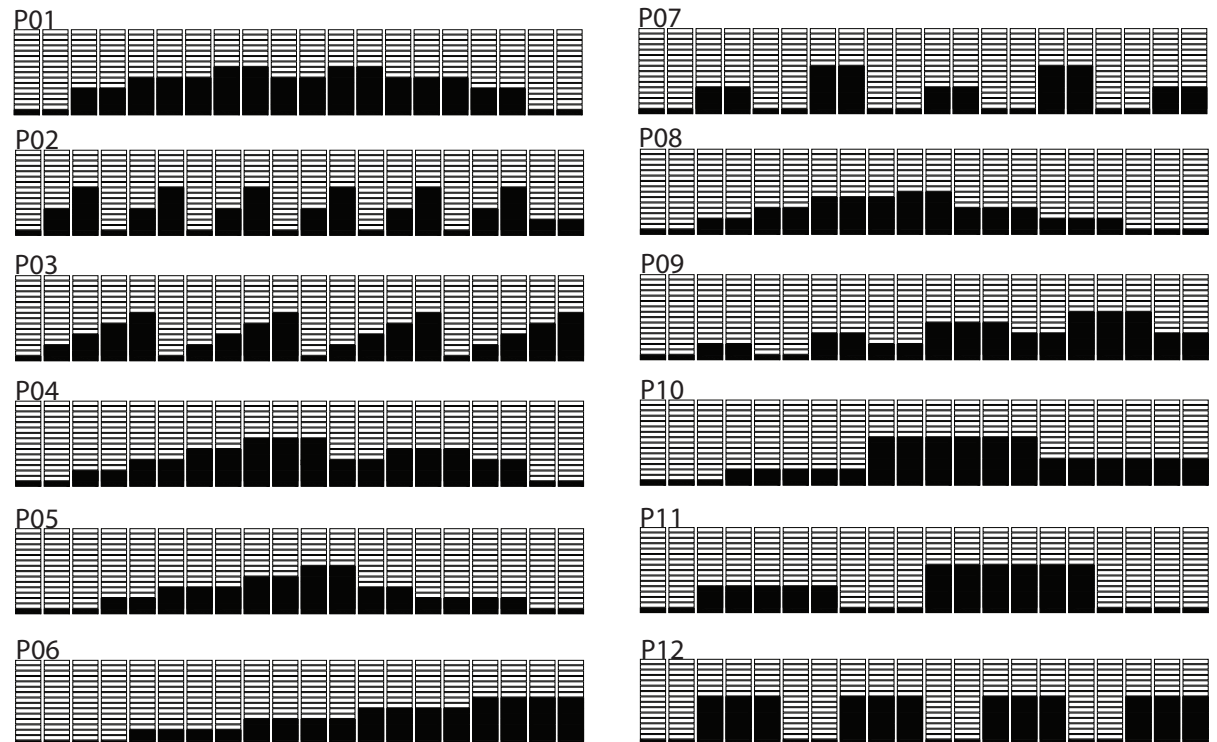

## MONITORING YOUR HEART RATE:

To obtain the greatest cardiovascular benefits from your exercise workout, it is important to work within your target heart rate zone. The American Heart Association (AHA) defines this target as 60%-75% percent of your maximum heart rate. Your maximum heart rate may be roughly calculated by subtracting your age from 220. Your maximum heart rate and aerobic capacity naturally decreases as you age. This may vary from one person to another, but use this number to find your approximate effective target zone. For example, the maximum heart rate for an average 40 year-old is 180 bpm. The target heart rate zone is 60%-75% of 180 or 108-135 bpm. See Fitness Safety on next page.

Before beginning your workout, check your normal resting heart rate. Place your fingers lightly against your neck, or against your wrist over the main artery. After finding your pulse, count the number of beats in 10 seconds. Multiply the number of beats by six to determine your pulse rate per minute. We recommend taking your heart rate at these times; at rest, after warming up, during your workout and two minutes into your cool down, to accurately track your progress as it relates to better fitness. During your first several months of exercising, the AHA recommends aiming for the lower part of the target heart rate zone-60%, then gradually progressing up to 75%.

According to the AHA, exercising above 75% of your maximum heart rate may be too strenuous unless you are in top physical condition. Exercising below 60% of your maximum will result in minimal cardiovascular conditioning. Check your pulse recovery rate – If your pulse is over 100 bpm five minutes after you stop exercising, or if it's higher than normal the morning after exercising, your exertion may have been too strenuous for your current fitness level. Rest and reduce the intensity next time.

(MHR) = Maximum Heart Rate

(THR) = Target Heart Rate

$220 - \text{age} = \text{maximum heart rate (MHR)}$

$\text{MHR} \times .60 = 60\% \text{ of your maximum heart rate.}$

$\text{MHR} \times .75 = 75\% \text{ of your maximum heart rate.}$

For example, if you are 30 years old, your calculations will be as follows:

$$220 - 30 = 190$$

$$190 \times .60 = 114 \text{ (low end or 60\% of MHR)}$$

$$190 \times .75 = 142 \text{ (high end or 75\% of MHR)}$$

30 year-old (THR) Target Heart Rate would be 114-142

**Fitness Safety** - The Heart Rate chart indicates average rate for you. Your physician or health care professional can help you determine the exercise intensity that is appropriate for your age and condition.

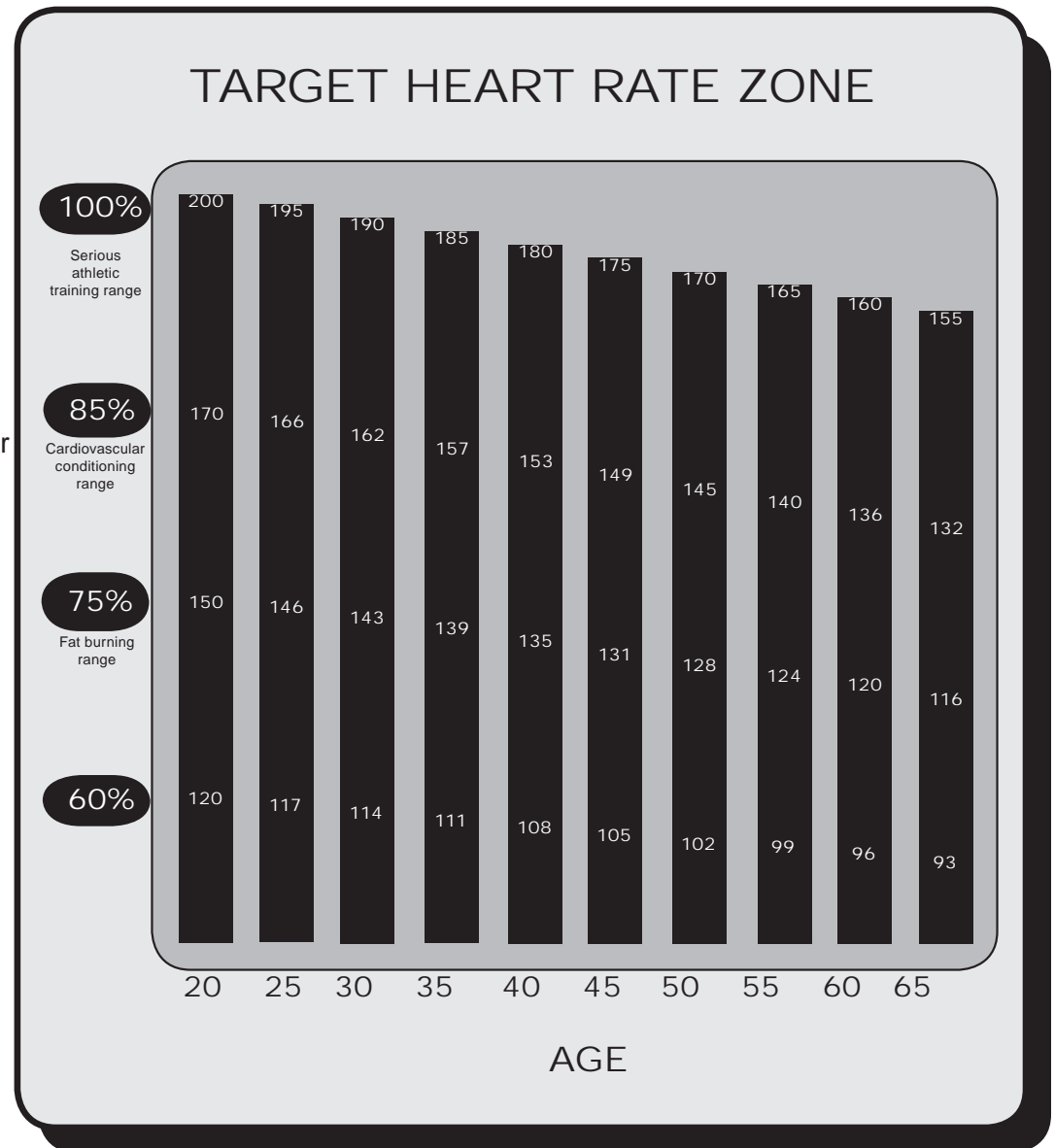

**IRONMAN** **Workout Information**  
*Fitness* [www.ironmanfitness.com](http://www.ironmanfitness.com)



**WARNING!**

Before beginning this or any exercise program, you should consult your physician. This is especially important for individuals over the age of 35 or individuals with pre-existing health problems. Flexibility is a key to fitness. Stretch all major muscle groups at least two to three times per week after a 5 to 10 minute warmup. Stretch just to the point of a gentle tug. If you have back, joint, or other health problems, talk to your doctor first



**Prone on Elbows**

Lie on your stomach with your feet together. Rest on your forearms with your elbows directly under your shoulders. Relax lower back and abdomen into the floor. Hold for 30-60 seconds or until muscles feel looser



**Supine Lumbar Rotation**

Lie on your back with your knees bent. Keeping your knees together against the floor, roll your knees to one side until you feel a stretch in your back or hip. Hold for 30-60 seconds or until muscles feel looser. Repeat on opposite side.



**Knees to Chest**

Lie on your back. Bend your knees, and lift your feet off the floor. Grasp your knees with your arms and pull your knees toward your chest. Hold for 20 Repeat three to five times..



**Cat and Camel**

Rest on your hands and knees. Round your back by contracting your abdominal muscles and tucking in your pelvis; hold for five seconds. Then allow your back to sag toward the floor as you lift your chest and head; hold for five seconds. Repeat the combination 10 times.



**Cervical Side Bends**

Tilt your head gently toward one shoulder, keeping your shoulders level and your face pointed straight ahead. Hold for five seconds, then tilt your head toward the other shoulder. and hold for five seconds. Repeat five times on each side.

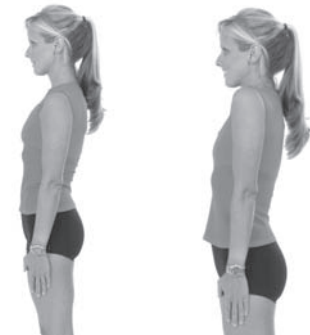

**Shoulder Circles**

In a smooth, continuous motion, make a circle with your shoulders: Raise them up towards your ears, pull them together behind you, lower them to a resting position, then roll them forward. Repeat then roll them forward. Repeat 10 times.



### Wrist Extensor

Extend your right arm in front of you with your palm up and your elbow straight. Point your fingertips toward the floor by bending at the wrist. Using your left hand, pull the back of your right hand toward you gently. Hold for 20 seconds; repeat three to five times with each arm.



### Wrist Flexor

Extend your right arm in front of you, palm down, elbow straight. Point your fingertips toward the floor by bending at the wrist. Using your left hand, pull your right palm toward you gently. Hold for 20 seconds; repeat three to five times with each arm.



### Triceps Stretch

Place your right hand behind your head, palm facing your head. With your left hand, grasp your right elbow and pull downward until you feel a stretch in the back of your right arm. Hold for 20 seconds; repeat three to five times with each arm.



### One-Arm Pectoralis Stretch

Stand against an immobile structure like a wall or a tree. While facing the wall, raise your right hand out to your side at chest height, palm against the wall. Turn your body toward the left, away from the wall and your extended arm, until you feel a stretch. Hold for 20 seconds; repeat three to five times with each arm.



### Piriformis Stretch

Lie on your back. Bend your right knee and lift it halfway to your chest. Grasp your knee with your left hand and pull it toward your left shoulder, keeping both buttocks against the floor. Hold for 20 seconds; repeat three to five times with each leg.



### Groin (Adductors) Stretch

Sitting with your back straight, bring the soles of your feet together. Let your knees lower toward the floor. Hold for 30-60 seconds or until muscles feel looser.



### Calf Stretch

Face a solid structure such as a wall with your left foot ahead of your right, toes straight ahead. Bend your left knee, press your hips forward, and lean into the wall. Keep both heels down, your right leg straight, and your left knee over your ankle. Hold for 20 seconds; repeat three to five times with each leg.



### Standing Quadriceps Stretch

Steady yourself with one hand. With the other, grab outside leg at ankle, keeping body straight from knee to hip. Gently pull foot up and towards the buttocks until you feel a stretch along the front of the thigh. Thigh should be pulled straight back and not drift to outside. Hold 20-30 seconds. For variation, grab opposite ankle (i.e., grab right ankle with left hand). Do two to three repetitions per leg.



### Achilles Stretch

Face the wall with your left foot ahead of your right, toes straight ahead. Bend both knees, press your hips forward, and lean into the wall. Keep both heels down and both knees in line with your feet. Hold for 20 seconds; repeat three to five times with each leg.

**IRONMAN** *Fitness* **Parts Information**  
[www.ironmanfitness.com](http://www.ironmanfitness.com)





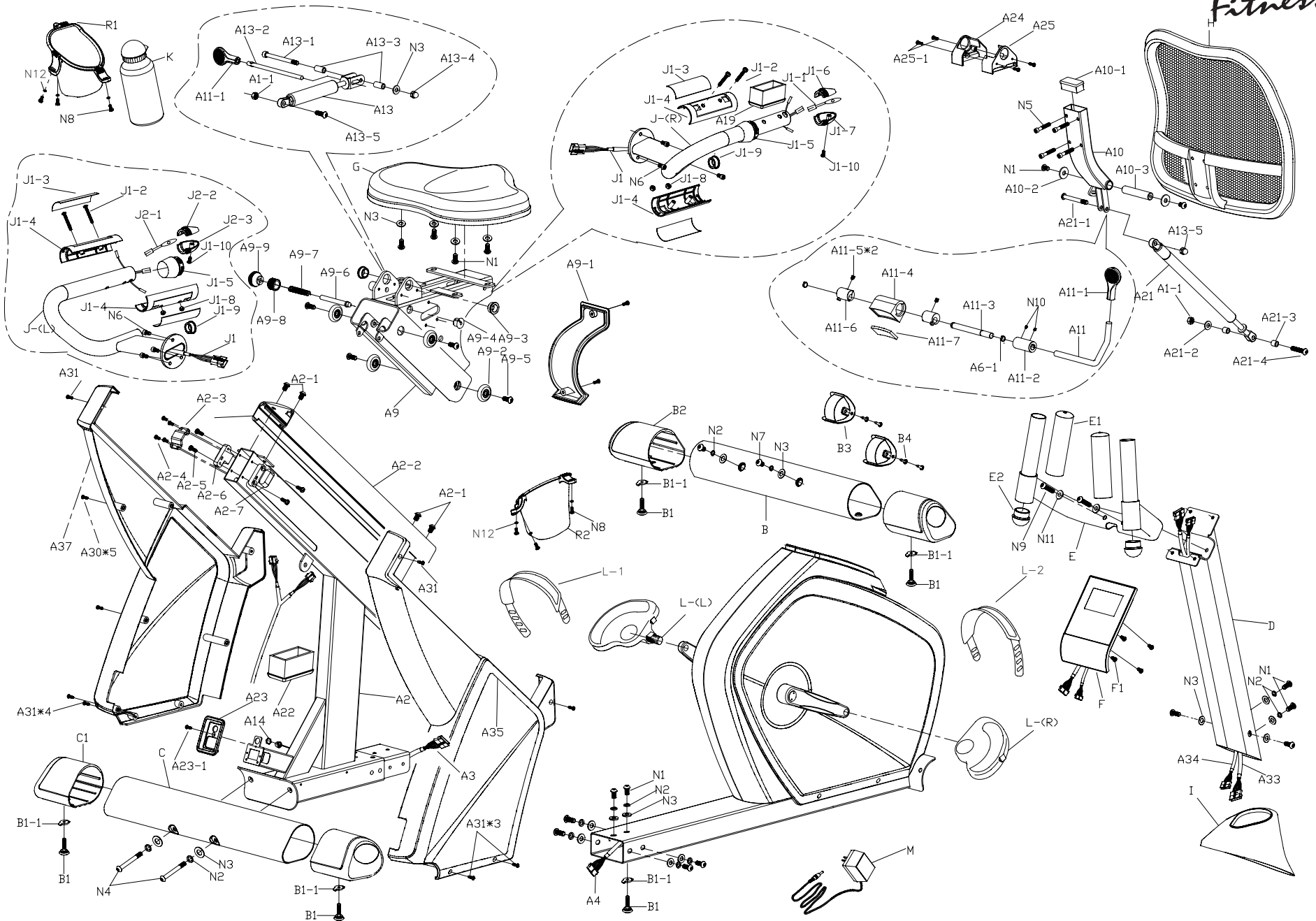

Transition Parts List Rev A

Ref #	Description	Qty	Ref #	Description	Qty
A1	MAIN FRAME, FRONT	1	A21-3	BUSHING, METAL	2
A1-1	NUT, M8	4	A21-4	BTN HD ALLEN BOLT, M8X50X20	1
A1-2	SCREW, M8X52	1	A22	PLUG, RECTANGULAR BLACK	1
A2	MAIN FRAME, REAR	1	A23	COVER, POWER RECEPTACLE	1
A2-1	BTN HD ALLEN BOLT, M8X10	4	A23-1	PHILLIPS SCREW, M4X12	1
A2-2	TRACK, ALUMINUM	1	A24	COVER, BACK SUPPORT LEFT	1
A2-3	STOPPER, CENTER	1	A25	COVER, BACK SUPPORT RIGHT	1
A2-4	SCREW, M4X10	4	A25-1	PHILLIPS SCREW, M4X20	4
A2-5	SCREW, M4X12	4	A26	CRANK LEFT	1
A2-6	STOPPER, LEFT BLACK	1	A27	SPRING	1
A2-7	STOPPER, RIGHT BLACK	1	A28	BRACKET, IDLER PULLEY	1
A3	WIRE HARNESS, EKG REAR	1	A28-1	BRACKET, IDLER PULLEY	1
A4	WIRE HARNESS, EKG MIDDLE	1	A28-2	HEX HD BOLT, M8X25	1
A5	NUT, 3/8X26X7mm	2	A28-3	FLAT WASHER, M10X24X0.3	2
A6	FLYWHEEL, MAG BRAKE	1	A28-4	FLAT WASHER, M8X22X1.5	1
A6-1	C-CLIP, C10	2	A28-5	C-CLIP, C12	1
A6-2	BEARING, 6300ZZ	1	A28-6	BEARING, 6001ZZ	1
A6-3	NUT, 3/8X5	1	A29	HOUSING, MAIN LEFT FRONT	1
A6-4	AXLE, MAG BRAKE	1	A30	PHILLIPS SCREW, M4X25	12
A6-5	PULLEY, MAG BRAKE	1	A31	PHILLIPS SCREW, M5X20	11
A6-6	BEARING, ONE WAY IC1735-FT	1	A32	HOUSING, MAIN RIGHT FRONT	1
A6-7	BEARING, 6000ZZ	1	A33	WIRE HARNESS, MAIN CONSOLE TUBE	1
A6-8	BEARING, 6300ZZ	2	A34	WIRE HARNESS, EKG CONSOLE TUBE	1
A7	BEARING, 6203ZZ	2	A35	HOUSING, MAIN RIGHT REAR	1
A8	MAGNETIC HOUSING	1	A36	GEAR BOX, W/ HARNESS	1
A8-1	FLAT WASHER, M6X16X1.2	1	A36-1	PHILLIPS SCREW, M6X10	4
A8-2	NUT, M6	5	A37	HOUSING, MAIN LEFT REAR	1
A8-3	FLAT WASHER, M6X19X1.5	1	B	STABILIZER, FRONT	1
A8-4	NUT, M6	1	B1	LEVELER BOLT, M8X29X42.5	5
A8-5	HEX HD BOLT, M6X60	1	B1-1	NUT, ADJUSTMENT	5
A8-6	CABLE, TENSION	1	B2	END CAP	2
A8-7	SPRING	1	B3	WHEELS, TRANSPORT W/ HOUSING	2
A9	SEAT CARRIAGE	1	B4	PHILLIPS SCREW, #8X32X5/8	4
A9-1	COVER, SEAT CARRIAGE	1	C	STABILIZER, REAR	1
A9-2	WHEEL, SEAT CARRIAGE	4	C1	END CAP	2
A9-3	BUSHING, METAL	2	D	CONSOLE TUBE	1
A9-4	PLUG, INNER BLACK	1	E	HANDLEBAR, FRONT	1
A9-5	BTN HD ALLEN BOLT, M8X22	4	E1	HANDLE, FOAM	2
A9-6	SHAFT, POP PIN	1	E2	PLUG, INNER	2
A9-7	SPRING, POP PIN	1	F	CONSOLE, CHANG YOW	1
A9-8	NUT, M16	1	F1	PHILLIPS SCREW, M5X10	4
A9-9	KNOB, ROUND BLACK	1	G	SEAT, BLACK	1
A10	SUPPORT, BACK PAD	1	H	BACK PAD, MESH	1
A10-1	PLUG, INNER BLACK	1	I	COVER, CONSOLE TUBE	1
A10-2	FLAT WASHER, M8X25X2	2	J-(L)	HANDLEBAR, LEFT REAR	1
A10-3	AXLE, BACK SUPPORT	1	J-(R)	HANDLEBAR, RIGHT REAR	1
A11	HANDLE, SEAT ADJUSTMENT	1	J1	WIRE HARNESS, EKG/TOGGLE REAR L/R	1
A11-1	KNOB, FLAT BLACK	1	J1-1	MEMBRANE, TOGGLE RIGHT	1
A11-2	TUBE, CONNECTING	1	J1-2	PHILLIPS SCREW, M3X35	2
A11-3	AXLE, BRAKE	1	J1-3	PLATE, EKG	1
A11-4	MOUNT, BRAKE PAD	1	J1-4	HANDLE, EKG	1
A11-5	SET SCREW, M6X10	2	J1-5	COVER, TOGGLE LEFT/RIGHT REAR	1
A11-6	BUSHING, BRAKE ASSY	1	J1-6	COVER, TOGGLE RIGHT TOP	1
A11-7	BRAKE PAD	1	J1-7	COVER, TOGGLE RIGHT BOTTOM	1
A11-8	BUSHING, BRAKE ASSEMBLY LEFT	1	J1-8	NUT, M3	4
A12	SPEED SENSOR, W/ WIRE	1	J1-9	PLUG, INNER CIRCULAR BLACK	2
A13	GAS SHOCK, SEAT CARRIAGE	1	J1-10	PHILLIPS SCREW, M4X10	1
A13-1	SOCKET HD ALLEN BOLT, M8X95	1	J2-1	MEMBRANE, TOGGLE LEFT	1
A13-2	HANDLE, GAS SHOCK	1	J2-2	COVER, TOGGLE LEFT TOP	1
A13-3	BUSHING, PLASTIC	2	J2-3	COVER, TOGGLE LEFT BOTTOM	1
A13-4	CAP NUT, M8	2	K	WATER BOTTLE, IVIVA BLACK	1
A13-5	CAP NUT, M8	1	L(R)	PEDAL, RIGHT	1
A13-6	KNOB, FLAT BLACK	1	L(L)	PEDAL, LEFT	1
A13-7	NUT,	1	L1	STRAP, PEDAL LEFT	1
A13-8	BTN HD ALLEN BOLT,	1	L2	STRAP, PEDAL RIGHT	1
A14	WIRE, POWER REAR	1	M	AC ADAPTER, 9V 1000mA USA	1
A15	MOUNT, SPEED SENSOR	1	N1	BTN HD ALLEN BOLT, M8X15	16
A16	PHILLIPS SCREW, #6-32X12L	1	N2	SPRING WASHER, M8	12
A17	CRANK ARM, RIGHT	1	N3	FLAT WASHER, M8X16X1.2	19
A17-1	HEX WASHER HD BOLT, M8X25	2	N4	BTN HD ALLEN BOLT, M8X105	2
A17-2	PLUG, INNER BLACK	2	N5	SOCKET HD ALLEN BOLT, 1/4X40	4
A17-3	BELT, POLY-V 6PJ46	1	N6	SOCKET HD ALLEN BOLT, M6X12	6
A18	PULLEY, CRANK	1	N7	BTN HD ALLEN BOLT, M8X20	2
A18-1	C-CLIP, C17	2	N8	PHILLIPS SCREW, M4X15	6
A18-2	MAGNET, SPEED SENSOR	1	N9	BTN HD ALLEN BOLT, M8X35	2
A19	PLUG, RECTANGULAR BLACK	1	N10	SET SCREW, M6X8	2
A20	AXLE, CRANK	1	N11	WASHER M8	2
A20-1	HEX HD BOLT, M6X18	4	N12	FLAT WASHER, M8X4.5	6
A21	GAS SHOCK, BACK PAD	1	R1	ACCESSORY TRAY, LEFT	1
A21-1	BTN HD ALLEN BOLT, M8X70X20	1	R2	ACCESSORY TRAY, RIGHT	1
A21-2	FLAT WASHER, M8X16X1.2	3	#	BOLT PACK, TRANSITION	1

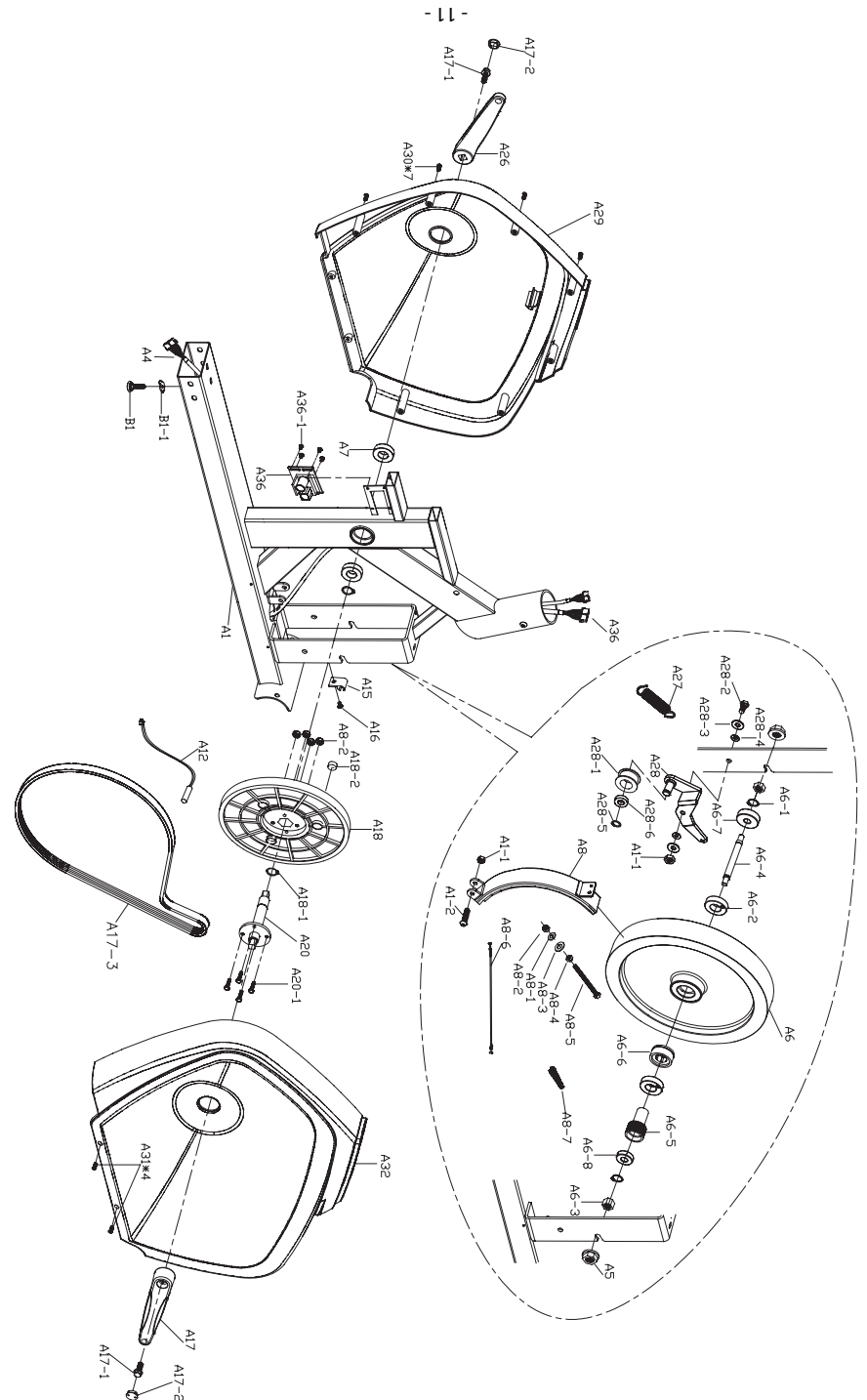

## Residential and Personal Use Limited Warranty

PLEASE READ THESE WARRANTY TERMS AND CONDITIONS FULLY AND CAREFULLY BEFORE USING YOUR IRONMAN FITNESS EQUIPMENT. BY USING THE EQUIPMENT, YOU ARE CONSENTING TO BE BOUND BY THE FOLLOWING TERMS AND CONDITIONS.

**Frame:** Lifetime **Parts:** 1 Year  
Missing/Cosmetic Parts: 30 Days  
**Limited Warranty**

This Limited Warranty applies in the United States and Canada to Products manufactured or distributed by IRONMAN Fitness under the IRONMAN Fitness ("IRONMAN") brand name (as used herein, the "Product" or "Products"). The warranty period to the original purchaser is listed above, and commences on the date of original purchase of the product, unless otherwise authorized by IRONMAN. IRONMAN warrants that the Product purchased from IRONMAN or from an authorized IRONMAN Fitness reseller "dealer" (for residential or personal use only, unless otherwise authorized by IRONMAN in writing), is free from defects in Materials and Workmanship relevant to the functionality of the Product at initial startup, under normal use, and during the applicable warranty period, unless otherwise determined by IRONMAN.

This warranty excludes expendable parts if primary cause for warranty claim is wear. Expendable parts pertain to components on the Product that are prone to normal wear and tear. These items vary by Product, and can include (but not limited to) hand grips, skid pads, pedals, pedal straps, poly-v belts, console overlays, toggle switch/button overlays, (luster free or dull) ekg plates, decals, and any other items that are not essential to the operation of the Product, unless otherwise determined by IRONMAN. This warranty extends only to you, the original purchaser. It is not transferable to anyone who subsequently purchases (or receives as a gift) the Product from you. Your sales receipt, showing the date/place of purchase and serial number (if applicable) of the Product, is your proof of purchase, and may be required by IRONMAN any time a warranty parts (or service) claim is made or if no warranty record exists for the product.

### Exclusive Remedies

During the warranty period listed above, IRONMAN will repair a Product by correcting any minor issues (either by phone or online support) that might be causing the Product failure. Should a technical service and support representative be unable to correct the issue, IRONMAN may replace the parts (with new parts or at the option of IRONMAN, with serviceable used parts, that are equivalent to new parts in performance) that become defective, malfunction, or otherwise fail to conform to this Limited Warranty under normal use.

Replacement parts shall be warranted for 30 days from the shipment reception date or through the end of the 'replaced' part warranty period, whichever is longer. Any replacement parts, required past the warranty period listed above, shall be subject to purchase a retail price, plus any added shipping and handling charges associated to the delivery of the part. Note that replacement parts may be available only through the lifetime (as defined) of the Product. In conforming to this warranty, IRONMAN (as the manufacturer) reserves the right to change manufacturers or vendors of any part to cover the existing warranty.

IRONMAN may also provide service (if deemed necessary and if applicable) at no charge to you during (and not to exceed) the service warranty period listed above, in an attempt to repair the Product. Should the Product require service at your request or out of the limited warranty period, IRONMAN can furnish contact information for local (to your area) IRONMAN authorized service providers. Service quotes, costs, and scheduling will be strictly dependent on service provider rates and mutual (consumer/provider) service agreements. IRONMAN is not responsible for any service repair costs accrued through the use of authorized IRONMAN service providers at your request or out of the limited warranty period (without written consent from IRONMAN), beyond the limitations outlined on this warranty.

### Replacements and Returns

If after a reasonable number of attempts, a defect has not been repaired (or the Product is deemed non-repairable by IRONMAN technical service and support staff), IRONMAN, based on a case by case review, may opt to replace the Product, or recommend an alternate resolution, such as a warranty buy-out (Product cost, subject to deduction of a reasonable charge for usage) or a credit. IRONMAN, as a manufacturer, reserves the right to replace the Product with a Factory-Reconditioned Product that meets or exceeds standards comparable to those of the replaced Product. The warranty covering the replacement Product shall expire on the date the original warranty for the replaced Product would have expired, unless otherwise determined by IRONMAN.

### Conditions and Restrictions

This warranty DOES NOT (A) cover shipping and handling charges, export taxes, custom duties and taxes, or any other charges associated with transportation of the parts or Product, beyond the initial courtesy period of 60 days from original date of purchase of the Product; (B) extend to Products not purchased from IRONMAN or from an authorized IRONMAN reseller; (C) extend to Products purchased from online auction sites; (D) cover any extended, additional, or third party warranties if not offered exclusively by IRONMAN in writing; (E) cover Products installed at fee based facilities/commercial environments (gyms, homes used as wellness centers, etc.); (F) cover Products installed in light institutional environments (non fee-based facilities include for example, and not be way of limitation, fire houses, police departments, rehab centers, hospitals, clinics, apartment

complexes, club houses, etc.); (G) cover service calls to correct installation, perform maintenance, or instruct owners on how to use the equipment; or (H) cover a Product on which the serial number has been purposefully or accidentally defaced or removed and there is no proof of purchase available (if serial number is applicable), unless authorized by IRONMAN in writing or otherwise stated on this warranty.

This Limited Warranty becomes void for Products that have been damaged or rendered defective as a result of (a) accident, misuse, or abuse (including but not limited to exceeding the IRONMAN listed, maximum weight limit); (b) use of parts not manufactured or sold by IRONMAN; (c) modification of the Product; (d) normal wear and tear; (e) operation on incorrect power supplies; (f) \*\*\*failure to perform (or performing improper) maintenance; (g) service by anyone other than IRONMAN, or an authorized IRONMAN warranty service provider; (h) floods, fires, earthquakes, lightning strikes, power surges, and other unavoidable acts of nature; (i) residential mis-wires; or (k) incorrect setup, installation, or assembly. Should any Product (submitted for warranty parts replacement) be found ineligible under the terms outlined on this warranty, an estimate for parts purchase (if available) can be furnished at your request.

\* Parts is herein defined exclusively, for all intents and purposes, and pertaining to this Limited Manufacturer Warranty, as components or Materials essential to the functionality of the Product.

\*\*Lifetime of a Product, is herein defined exclusively, for all intents and purposes, and pertaining to this Limited Manufacturer Warranty, as the time period 7 years beyond the end of production cycle of a Product in question.

### Disclaimer and Release

EXCEPT AS EXPRESSLY SET FORTH IN THIS WARRANTY, IRONMAN MAKES NO OTHER WARRANTIES, EXPRESSED OR IMPLIED, INCLUDING ANY IMPLIED WARRANTIES OF MERCHANTABILITY AND FITNESS FOR A PARTICULAR PURPOSE. IRONMAN EXPRESSLY DISCLAIMS ALL WARRANTIES NOT STATED IN THIS LIMITED WARRANTY. ANY IMPLIED WARRANTIES THAT MAY BE IMPOSED BY LAW ARE LIMITED TO THE TERMS OF THIS LIMITED WARRANTY. NEITHER IRONMAN NOR ANY OF ITS AFFILIATES SHALL BE RESPONSIBLE FOR INCIDENTAL OR CONSEQUENTIAL DAMAGES. SOME STATES DO NOT ALLOW LIMITATIONS ON IMPLIED WARRANTIES OR THE EXCLUSION OR LIMITATION OF INCIDENTAL OR CONSEQUENTIAL DAMAGES, SO THE ABOVE LIMITATIONS OR EXCLUSIONS MAY NOT APPLY TO YOU. THIS LIMITED WARRANTY GIVES YOU SPECIFIC LEGAL RIGHTS AND YOU MAY ALSO HAVE OTHER RIGHTS THAT MAY VARY FROM STATE TO STATE. THIS IS THE ONLY EXPRESS WARRANTY APPLICABLE TO IRONMAN-BRANDED PRODUCTS. IRONMAN NEITHER ASSUMES NOR AUTHORIZES ANYONE TO ASSUME FOR IT ANY OTHER EXPRESS WARRANTY.



[www.ironmanfitness.com](http://www.ironmanfitness.com)

Ironman Fitness

4009 Distribution Drive, Suite 250

Garland, Texas 75041

Customer Service: 1-800-750-4766

IRONMAN, IRONMAN TRIATHLON and M-DOT are registered trademarks of World Triathlon Corporation. This product is licensed by the IRONMAN TRIATHLON.

## Free Manuals Download Website

<http://myh66.com>

<http://usermanuals.us>

<http://www.somanuals.com>

<http://www.4manuals.cc>

<http://www.manual-lib.com>

<http://www.404manual.com>

<http://www.luxmanual.com>

<http://aubethermostatmanual.com>

Golf course search by state

<http://golfingnear.com>

Email search by domain

<http://emailbydomain.com>

Auto manuals search

<http://auto.somanuals.com>

TV manuals search

<http://tv.somanuals.com>