

# IRONMAN

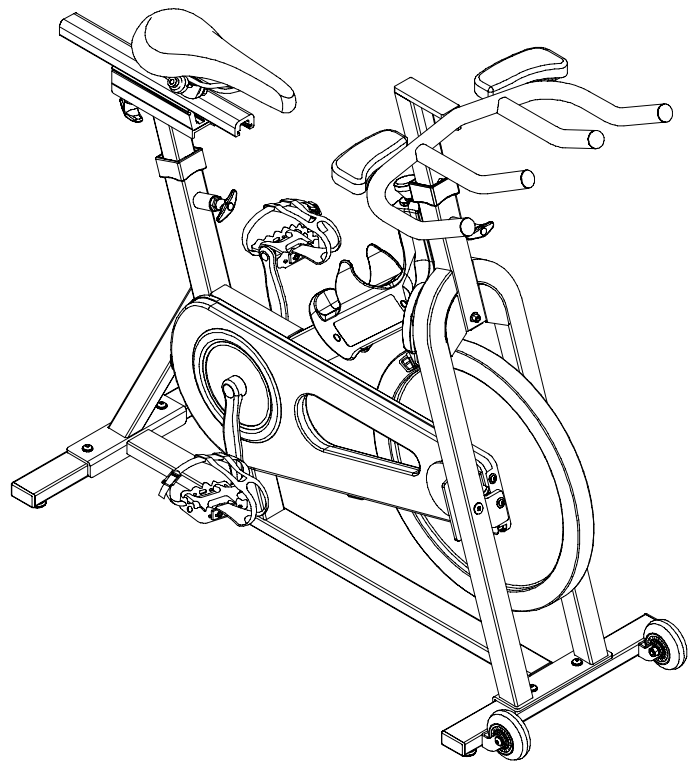

## 112i

OWNER'S MANUAL

315-00032

07/05 Rev B

Official product of the Ironman Triathlon

**Congratulations** on choosing an Ironman Fitness product. The Ironman 112M Bike was designed with the aggressive rider in mind and is a tremendously effective tool for achieving your personal fitness goals.

Named after the 112 mile bike portion of the Ironman Triathlon, you will be able to rely on the quality craftsmanship and durability of the Ironman 112M Bike for years to come.

This owner's manual contains all the information you need to operate and enjoy your Ironman 112M Bike. Please read the manual in its entirety before attempting to exercise on the 112M Bike.

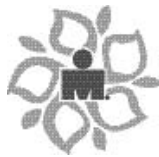

### QUESTIONS?

Call our toll free Ironman Fitness Helpline at

**1.800.750.IRON**  
**1.800.750.4766**

Prior to your call, please be sure you have located and noted the Model Number and Serial Number.

**[ironmanfitness.com](http://ironmanfitness.com)**

## FITNESS SAFEGUARDS

**Failure to follow any of these safeguards may result in injury or serious health problems.**

- Before starting any exercise program, consult with your physician or health professional. He or she can help establish the exercise frequency, intensity and time appropriate for your particular age and condition.
- If you have any pain or tightness in your chest, an irregular heartbeat, shortness of breath, feel faint or have any discomfort while you exercise, STOP! Consult your physician before continuing.
- Do not place fingers or any other objects into moving parts of the exercise equipment.
- Keep children and pets away from the 112M Bike. A child's curiosity may result in injury.
- Do not allow children to use the 112M Bike. The machine is designed and intended for adults, not children.
- Never turn pedal crank arms by hand. To avoid entanglement and possible injury, do not expose hands or arms to the drive mechanism.
- Do not dismount the 112M Bike until the pedals are at a complete STOP.
- Warn bystanders to keep a safe distance. Do not allow anyone to touch the bike while it is in operation.

## ASSEMBLY PARTS LIST

<u>PART #</u>	<u>DESCRIPTION</u>	<u>QTY</u>
1	Handlebar	1
8	T-Pop Pin	1
10	Screw	2
11	Guard/Bottle Cage	1
26	Front Stabilizer	1
30	Allen Bolt	4
31	Washer	4
41	Rear Stabilizer	1
50R	Right Pedal	1
50L	Left Pedal	1
See Below	Wrench	1

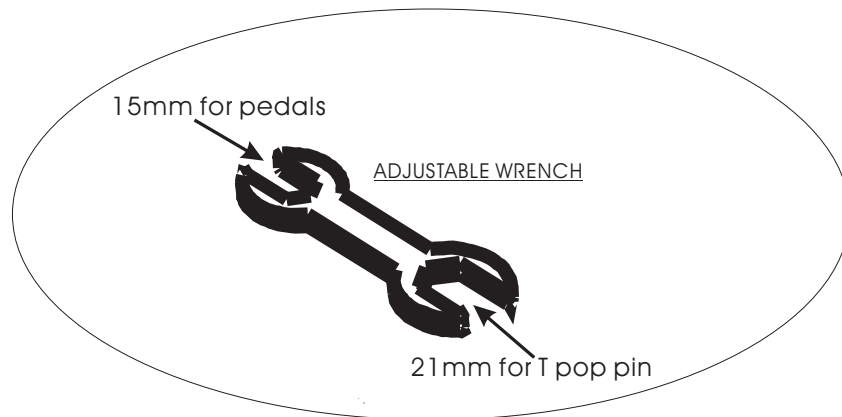

**2**

## ASSEMBLY INSTRUCTIONS

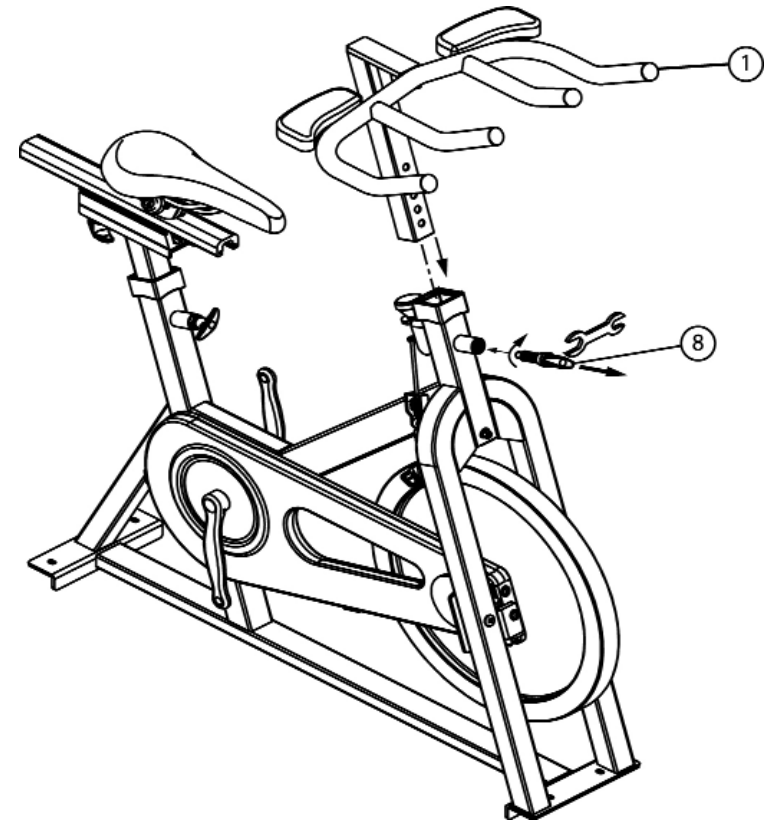

### STEP 1

Install the Pop Pin (8) into the head tube using wrench.

Insert the Handlebar (1) into the head tube and secure with Pop Pin (8). Make sure the Pop Pin (8) settles into the desired hole and then secure it firmly.

**3**

## ASSEMBLY INSTRUCTIONS

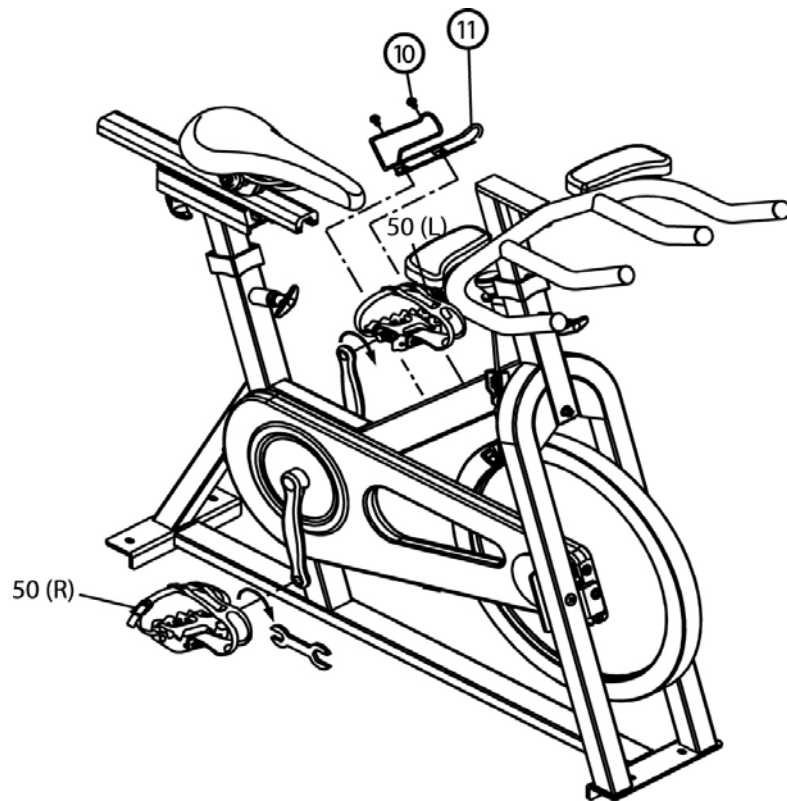

### STEP 2

Secure the Water Bottle Cage (11) to the main frame using the two Screws (10).

Thread the Right Pedal (50R) to the right side arm of the bike using the wrench provided. The Right Pedal has "R" marked on the spindle. Please note that the Right Pedal is right-hand threaded which must be turned clockwise to tighten.

Thread the Left Pedal (50L) to the left side arm of the bike using the wrench provided. The Left Pedal has "L" marked on the spindle. Please note that the Left Pedal is left-hand threaded which must be turned counter clockwise to tighten.

4

## ASSEMBLY INSTRUCTIONS

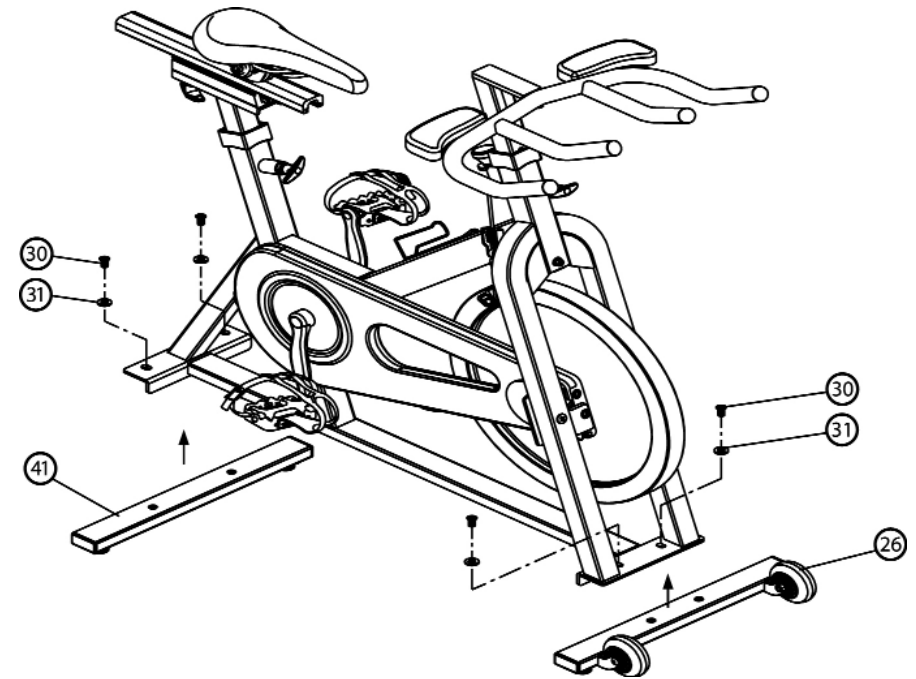

### STEP 3

Attach the Front Stabilizer (26) to the main frame using two Allen Bolts (30) and two Washers (31). Please make sure that the adjustable feet are on the bottom and the transport wheels are facing up and towards the front of the bike as pictured.

Attach the Rear Stabilizer (41) to the main frame using two Allen Bolts (30) and two Washers (31). Please also be aware that the adjustable feet are on the bottom.

5

## ASSEMBLY INSTRUCTIONS

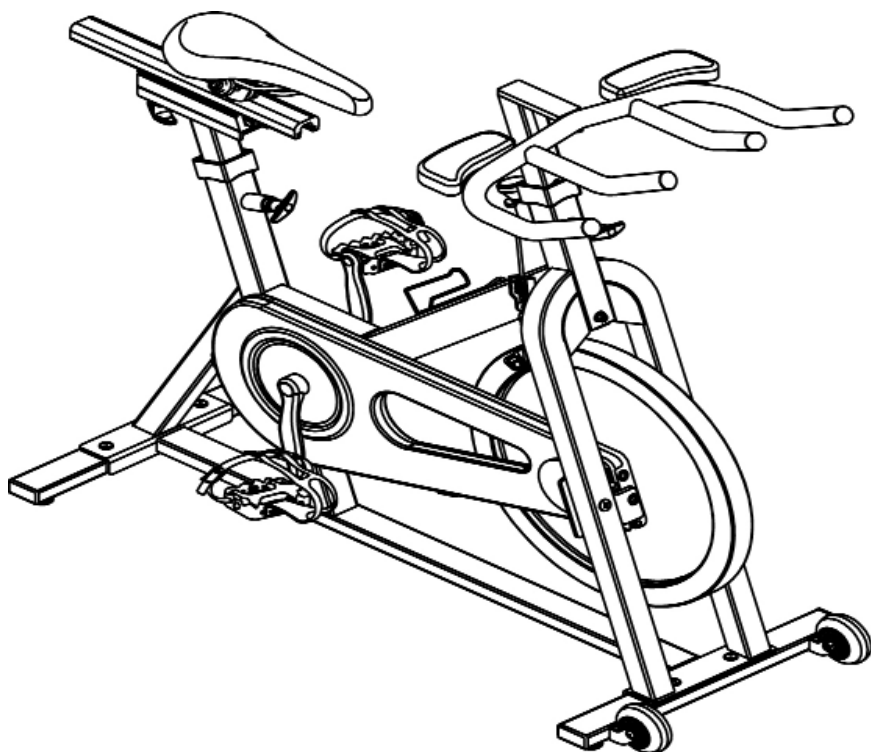

### STEP 4

You have completed the assembly of your new Ironman 112M Bike. Please read on for more important information related to operating and maintaining your 112M.

### **Moving Your 112M Bike**

To move the bike, carefully lift the rear end of the bike by pushing down on the front of the handlebars. Steer the bike to another location. Be gentle while moving the unit as any sharp impact can affect the operation.

### **Leveling Your 112M Bike**

The 112M Bike can be leveled to compensate for uneven surfaces. To level the bike, raise or lower the four leveling bolts located on the underside of the front and rear stabilizers by screwing them in or out as needed.

### **Maintenance**

Use a damp cloth to wipe your 112M Bike free from sweat after each use.

### **Monitoring Your Heart Rate**

To obtain the greatest cardiovascular benefits from your exercise workout, it is important to work within your target heart rate zone. The American Heart Association (AHA) defines this target as 60%-75% percent of your maximum heart rate.

Your maximum heart rate may be roughly calculated by subtracting your age from 220. Your maximum heart rate and aerobic capacity naturally decreases as you age. This may vary from one person to another, but use this number to find your approximate effective target zone. For example, the maximum heart rate for an average 40 year-old is 180 bpm. The target heart rate zone is 60%-75% of 180 or 108-135 bpm. See ***Fitness Safety*** on page 8.

Before beginning your workout, check your normal resting heart rate. Place your fingers lightly against your neck, or against your wrist over the main artery. After finding your pulse, count the number of beats in 10 seconds. Multiply the number of beats by six to determine your pulse rate per minute. We recommend taking your heart rate at these times; at rest, after warming up, during your workout and two minutes into your cool down, to accurately track your progress as it relates to better fitness.

During your first several months of exercising, the AHA recommends aiming for the lower part of the target heart rate zone-60%, then gradually progressing up to 75%. According to the AHA, exercising above 75% of your maximum heart rate may be too strenuous unless you are in top physical condition. Exercising below 60% of your maximum will result in minimal cardiovascular conditioning.

Check your pulse recovery rate – If your pulse is over 100 bpm five minutes after you stop exercising, or if it's higher than normal the morning after exercising, your exertion may have been too strenuous for your current fitness level. Rest and reduce the intensity next time.

**FITNESS SAFETY:** A variety of different factors (including medication, emotional state, temperature and other conditions) can affect the target heart rate zone that is best for you. Your physician or health care professional can help you determine the exercise intensity that is appropriate for your age and condition.

(MHR) = Maximum Heart Rate      (THR) = Target Heart Rate

220 - age = maximum heart rate (MHR).

MHR x .60 = 60% of your maximum heart rate.

MHR x .75 = 75% of your maximum heart rate.

For example, if you are 30 years old, your calculations will be as follows:

$$220 - 30 = 190$$

$$190 \times .60 = 114 \text{ (low end or 60\% of MHR)}$$

$$190 \times .75 = 142 \text{ (high end or 75\% of MHR)}$$

30 year-old (THR) Target Heart Rate would be 114-142.

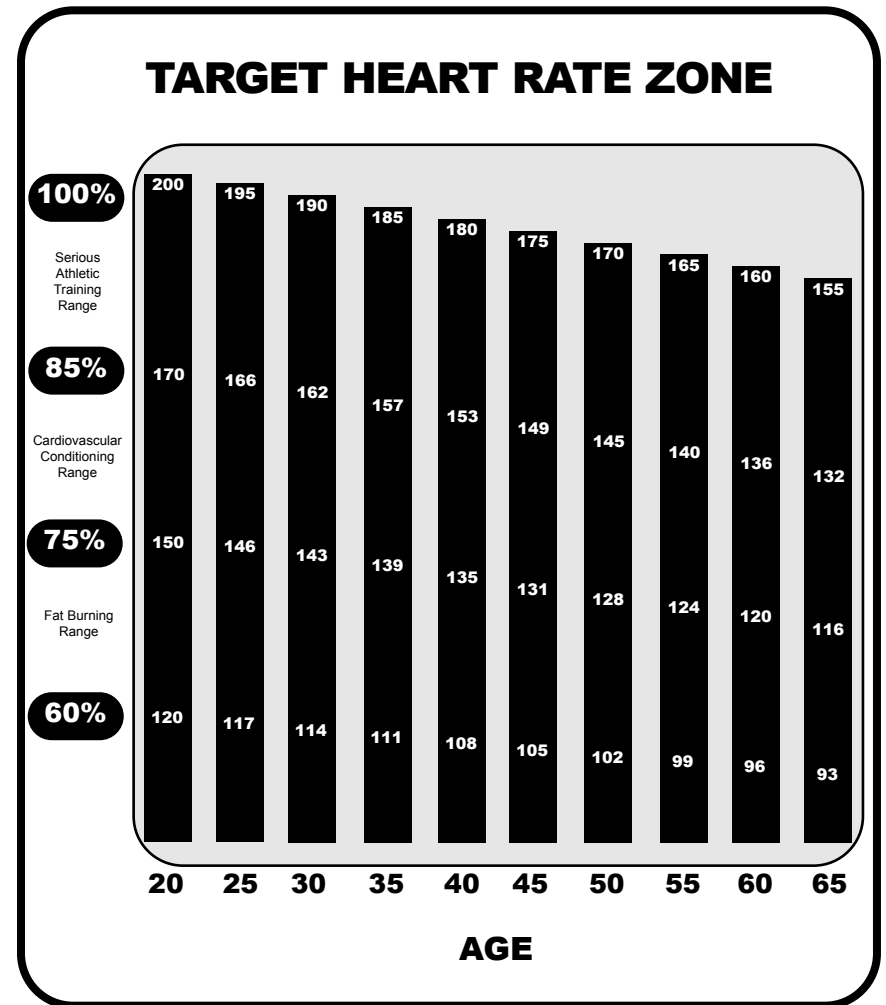

# PARTS LIST

# EXPLODED VIEW

112M Parts List Rev C

REF #	PART #	DESCRIPTION	QTY
1	323-00035	HANDLEBAR 112M	1
2	302-00320	WASHER 16*6.5*1MM	12
3	302-00323	PAN HEAD ALLEN BOLT M5*12MM M-CT & 112M	11
4	328-00025	RACING PAD R	1
4-1	328-00026	RACING PAD L	1
5	310-00131	TENSION CONTROL KNOW M-CT & 112M	1
6	310-00138	ACOUSTIC GROMMET (NYLON)	1
7	306-00360	SLEEVE, 112M	2
8	310-00132	T-POP PIN (HANDLEBAR STEM ) M-CT & 112M	1
9	310-00133	T-POP PIN (SEAT POST) M-CT & 11M	1
10	302-00418	ROUND HEAD ALLEN BOLT #10 112M	2
11	310-00139	BOTTLE CAGE 112(OLD STYLE)	1
12	323-00186	FRAME M-CT & 112M	1
13	302-00084	BRAKE ASSEMBLY W/O BRAKE SHOE 112M	1
14	306-00371	ACOUSTIC GROMMET (PVC) 112M	1
15	302-00419	WASHER #15 112M	1
16	302-00420	NYLON NUT #16 112M	1
17	310-00017	BRAKE PADS (L&R) 112M	1
18	302-00421	POSITIONED NUT #18 112M	1
19	302-00422	NYLON NUT #19 112M	1
20	310-00017	BRAKE PADS (L&R) 112M	1
21	306-00243	FOOT CAP M-CT & 112M	4
22	302-00332	ROUND HEAD ALLEN BOLT M6*1.0*40	2
23	306-00244	TRANSPORT WHEEL M-CT & 112M	2
24	302-00433	LEVER NUT #24 112M	4
25	306-00603	LEVELER FOOT M-CT & 112M	4
26	323-00187	FRONT STABILIZER M-CT & 112M	1
27	302-00333	FLANGE NUT M12*1.25 M-CT & 112M	2
28	319-00015	FLYWHEEL DROPOUT PLATE (L ) M-CT & 112M	1
29	306-00248	END CAP M-CT & 112M	2
30	302-00334	Pan Head Allen Bolt M8*1.25*16 M-CT & 11	4
31	302-00329	FLAT WASHER 13*5 M-CT & 112M	4
33	319-00016	EZ RELEASE SET M-CT & 112M	1
34	302-00336	SNAP RING M-CT & 112M	1
35	302-00337	SPACER M-CT & 112M	1
36	311-00013	FLYWHEEL (MAIN) 112M	1
37	330-00054	HUB AXLE SET	1
40	319-00017	FLYWHEEL DROPOUT PLATE (R ) M-CT & 112M	1
41	323-00189	REAR STABILIZER M-CT & 112M	1
42	323-00082	SEAT POST 112M	1
43	302-00341	PAN HEAD ALLEN BOLT M6*1.0*12	4
43-1	302-00342	SPRING WASHER M6	4
44	328-00027	SEAT M-CT & 112M	1
45	319-00018	UPPER SEAT SLIDER ASSEMBLY M-CT & 112M	1
46	319-00019	LOWER SEAT SLIDER ASSEMBLY M-CT & 112M	1
47	319-00020	STEP PLATE M-CT & 112M	1
48	319-00021	CHAIN GUARD ( INNER ) M-CT	1
49	302-00343	PAN HEAD ALLEN BOLT M6*1.0*8	1
50	306-00111	PEDAL 112M	1
51	319-00022	CRANK (L) M-CT	1
51-1	302-00344	B/B BOLT M8*1.25	2
51-2	306-00248	END CAP M-CT & 112M	2
52	319-00023	BOTTOM BRACKET W/ ADAPTOR M-CT	1
53	302-00345	CHAIN 114 LINKS	1
54	330-00035	CHAIN WHEEL SET	1
55	319-00025	CHAIN GUARD ( OUTER ) M-CT	1
56	310-00135	T-POP PIN (SLIDER)	1
56-1	302-00346	DESPRESSED SPRING	1
56-2	319-00026	SLIDING GROOVE M-CT	1
56-3	302-00328	ROUND HEAD SCREW M5*0.8*30 M-CT & 112M	1
#	315-00032	OWNER'S MANUAL, 112M	1

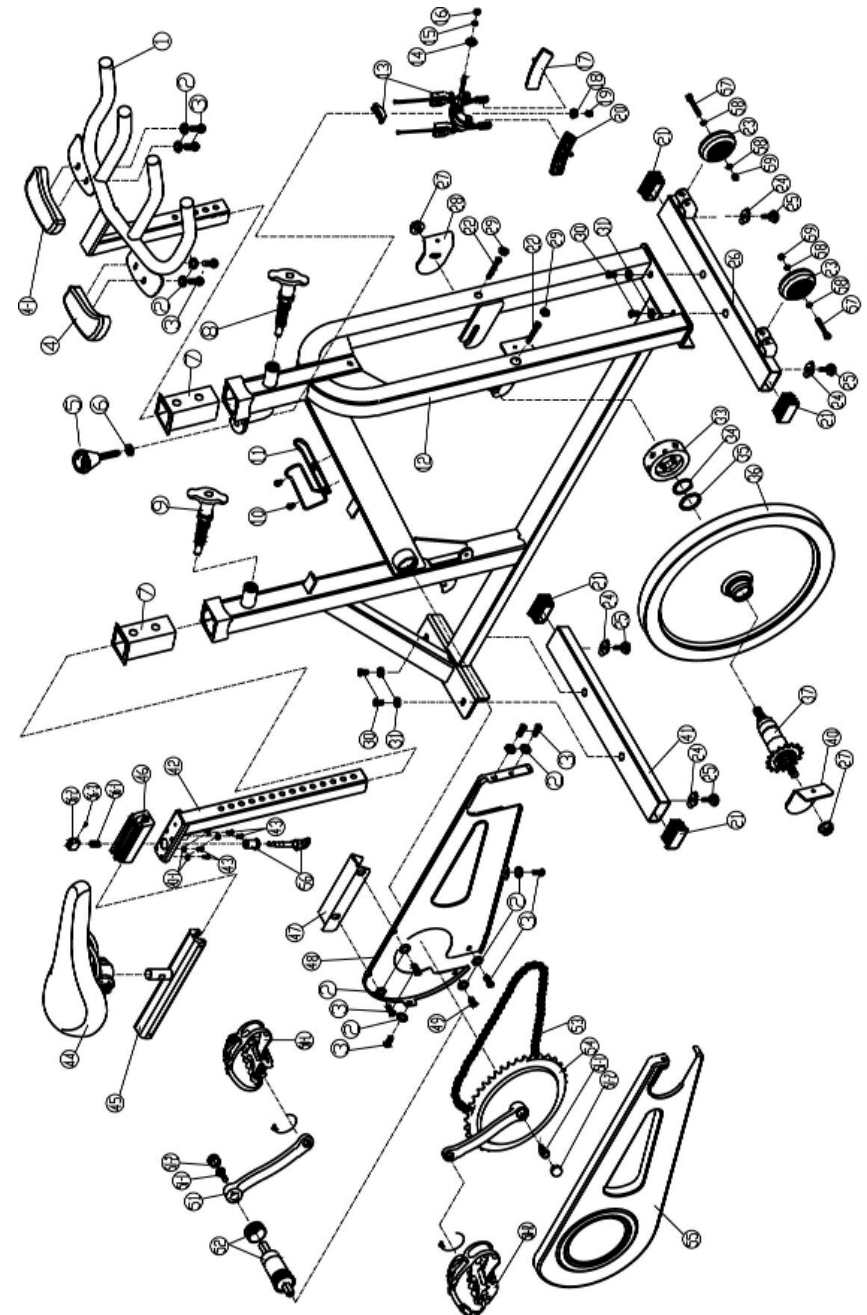

# IRONMAN FITNESS LIMITED WARRANTY

## Residential Warranty

30 Years Frame  
3 Years Parts  
1 Year Labor  
1 Year Wear Items

## Commercial Warranty

15 Years Frame  
2 Years Parts  
1 Year Labor  
6 Months Wear Items

This Limited Warranty applies in the United States and Canada to products manufactured or distributed by Ironman Fitness ("Ironman") under the Ironman brand name. The warranty period to the original purchaser is listed above in the table.

Ironman warrants that the Product you have purchased for use from Ironman or from an authorized Ironman reseller is free from defects in materials or workmanship under normal use during the warranty period. Your sales receipt, showing the date of purchase of the Product, is your proof of purchase. This warranty only extends to you, the original purchaser. It is not transferable to anyone who subsequently purchases the Product from you. It excludes expendable parts (wear items). Wear items pertain to components that might need to be replaced due to normal wear and tear. These items vary per product but will include pedal straps, seats, grips, chains, bottom bracket assemblies, pads, etc. Please contact an Ironman customer service representative for specifics on wear items. This Limited Warranty becomes VALID ONLY if the product is purchased through an Ironman Fitness authorized dealer unless otherwise authorized by Ironman Fitness in writing.

During the warranty period Ironman will repair or replace (at Ironman's option) the product if it becomes defective, malfunctions, or otherwise fails to conform with this Limited Warranty under normal use. In repairing the Product, Ironman may replace defective parts, or at the option of Ironman, serviceable used parts that are equivalent to new parts in performance. All exchanged parts and Products replaced under this warranty will become the property of Ironman. Ironman reserves the right to change manufacturers of any part to cover any existing warranty.

This warranty DOES NOT COVER shipping charges, export taxes, custom duties and taxes, or any other charges associated with transportation of the parts or Product.

To obtain warranty service, you must contact an Ironman authorized retailer, service technician or Ironman Fitness at our phone number located in this manual. Any parts determined to be defective must be returned to Ironman to obtain warranty service. You must prepay any shipping charges, export taxes, custom duties and taxes, or any other charges associated with transportation of the parts or Product. In addition, you are responsible for insuring any parts or Product shipped or returned. You assume the risk of loss during shipment. You must present Ironman with proof-of-purchase documents (including the date of purchase). Any evidence of alteration, erasing or forgery of proof-of-purchase documents will be cause to void this Limited Warranty.

This warranty does not extend to any product not purchased from Ironman or from an authorized Ironman reseller. This Limited Warranty does not extend to any Product that has been damaged or rendered defective; (a) as a result of accident, misuse, or abuse; (b) by the use of parts not manufactured or sold by Ironman; (c) by modification of the Product or normal wear and tear; (d) operation on incorrect power supplies; or (e) as a result of service by anyone other than Ironman, or an authorized Ironman warranty service provider. Product on which the serial number has been defaced or removed is not eligible for warranty service. Should any Product submitted for warranty service be found ineligible, an estimate of repair cost will be furnished and the repair will be made if requested by you upon Ironman's receipt of payment or acceptable arrangements for payment.

EXCEPT AS EXPRESSLY SET FORTH IN THIS WARRANTY, IRONMAN MAKES NO OTHER WARRANTIES, EXPRESSED OR IMPLIED, INCLUDING ANY IMPLIED WARRANTIES OF MERCHANTABILITY AND FITNESS FOR A PARTICULAR PURPOSE. IRONMAN EXPRESSLY DISCLAIMS ALL WARRANTIES NOT STATED IN THIS LIMITED WARRANTY. ANY IMPLIED WARRANTIES THAT MAY BE IMPOSED BY LAW ARE LIMITED TO THE TERMS OF THIS LIMITED WARRANTY. NEITHER IRONMAN NOR ANY OF ITS AFFILIATES SHALL BE RESPONSIBLE FOR INCIDENTAL OR CONSEQUENTIAL DAMAGES. SOME STATES DO NOT ALLOW LIMITATIONS ON HOW LONG AN IMPLIED WARRANTY LASTS OR THE EXCLUSION OR LIMITATION OF INCIDENTAL OR CONSEQUENTIAL DAMAGES. SO THE ABOVE LIMITATIONS OR EXCLUSION MAY NOT APPLY TO YOU. This Limited Warranty gives you specific legal rights and you may also have other rights that may vary from state to state. This is the only expressed warranty applicable to Ironman-branded products. Ironman neither assumes nor authorizes anyone to assume for it any other express warranty.

PLEASE SEND IN THE ATTACHED WARRANTY CARD WITHIN TEN (10) DAYS OF PURCHASE TO REGISTER YOUR UNIT WITH IRONMAN FITNESS.





**IRONMAN FITNESS**  
**4009 DISTRIBUTION DRIVE**  
**SUITE 250**  
**GARLAND, TEXAS 75041**  
**[ironmanfitness.com](http://ironmanfitness.com)**

## Free Manuals Download Website

<http://myh66.com>

<http://usermanuals.us>

<http://www.somanuals.com>

<http://www.4manuals.cc>

<http://www.manual-lib.com>

<http://www.404manual.com>

<http://www.luxmanual.com>

<http://aubethermostatmanual.com>

Golf course search by state

<http://golfingnear.com>

Email search by domain

<http://emailbydomain.com>

Auto manuals search

<http://auto.somanuals.com>

TV manuals search

<http://tv.somanuals.com>