

408GTi 508GTi
AUTOMOTIVE NEO/KEVLAR MATCHED
COMPONENT SYSTEM WITH CAST FRAME
INSTALLATION GUIDE

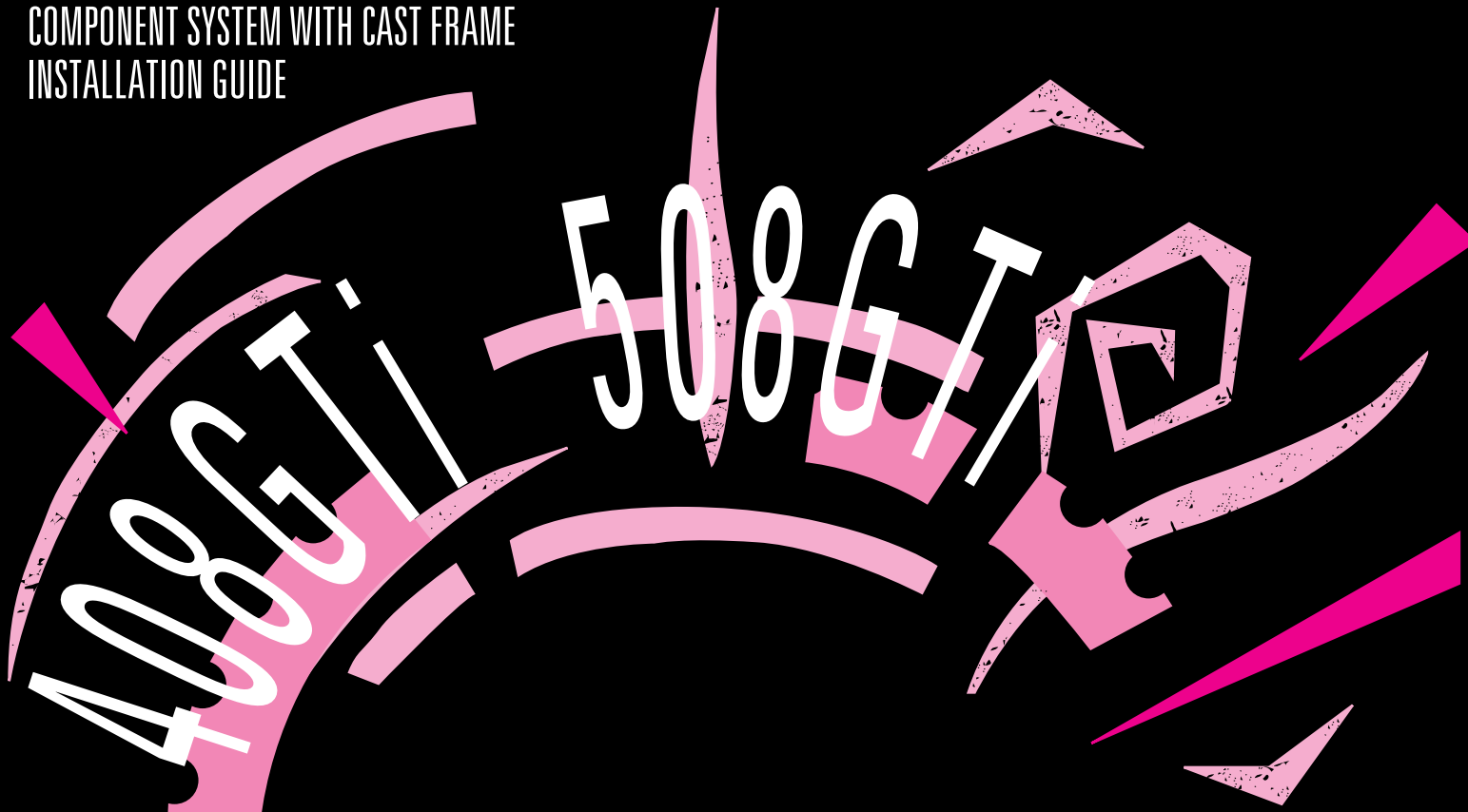
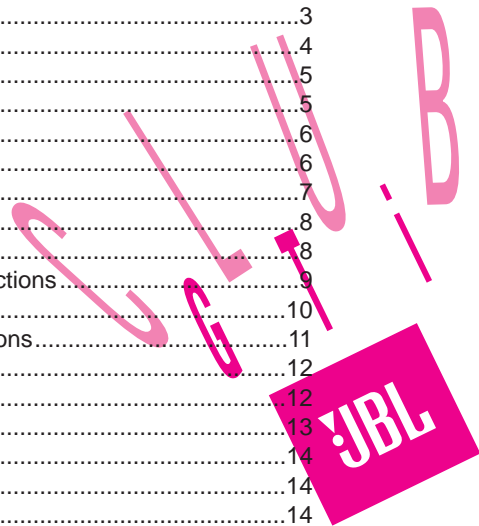

Table of Contents

Welcome to Club GTi	3
About this Manual	3
Autosound at its Best	3
Designing Your System	4
Component Placement.....	5
Installation Warnings and Tips	5
Mounting Instructions	6
Installing the GTi System Crossover	6
Woofer/Midrange Driver Mounting	7
Mounting the 408 and 508GTi Tweeter	8
Tweeter Surface Mounting Instructions	8
Tweeter Surface Angle Mounting Instructions.....	9
Tweeter Flush Mounting Instructions	10
Tweeter Flush Angle Mounting Instructions.....	11
Wiring	12
Crossover Tweeter Level Adjustment.....	12
System Connections	13
Speaker Break-In	14
A Note on Power Handling	14
In Case of Difficulty	14
Specifications	16
Thiele-Small Specifications	17
Mounting Templates	19



Welcome to Club GTi

Thank you for purchasing the finest Automotive Component Systems JBL has ever produced. As a GTi Competition Series owner, you are a member of a select group of people who enjoy the most advanced mobile audio products available. We call this group "Club GTi." By sending in the customer information card, which you will find attached to your warranty, we will automatically register you as a Club GTi member which will give you access to exclusive Club GTi apparel and other special offers we will make available from time to time. We suggest you fill the card out at your earliest convenience.

Also, be sure to save your sales receipt in a safe place. It will be necessary to use this document as proof of purchase in the event that you ever need warranty service. It is also useful for insurance purposes and for establishing value when you re-sell your vehicle.

About This Manual

Because of the performance capability of your GTi Competition Series product, and the variety of potential system configurations, we strongly recommend that you have the system professionally installed. You will also get a better warranty if your equipment is professionally installed by an authorized GTi dealer and you have your warranty card stamped. This manual provides information on installation and usage to help a skilled technician get the most from your GTi Competition Series product. This manual does not cover basic information about installation which is common knowledge to a professional installer, except for information which is unique to the 408 and 508GTi systems.

If you feel you possess the necessary skills, and prefer to install the equipment yourself, this manual will provide you with the necessary specifics to properly use the 408 or 508GTi in typical installations. Consult your JBL dealer, or a qualified technician, for more information.

Autosound at its Best

The 408 and 508GTi systems are built to meet the same rigorous standards of construction and performance that have long established JBL's renowned home and professional speaker systems. The 408 and 508GTi Woofer/Midranges incorporate advanced JBL woven Kevlar cones which are especially suited to the unique acoustic and environmental conditions which characterize automotive sound. The 408 and 508GTi Tweeter incorporates advanced JBL pure titanium technology which is especially suited to the unique acoustic environment of modern vehicles. The 408 and 508GTi have been engineered to provide excellent power handling, good dispersion and balanced frequency response, along with minimum size and flexible installation options for optimizing placement within the vehicle.

The small size of the GTi Drivers is made possible through the use of a Neodymium magnet assembly with JBL's Stray Field Containment Geometry. By

minimizing stray magnetic fields, this closed circuit magnetic assembly design concentrates the magnetic field on the voice coil where it provides superior performance. In the woofer/midrange drivers, this high concentration of magnetic power is coupled to a 2" Edge-wound Aluminum Wire Voice Coil on a High Temperature Fiberglass Former. This voice coil uses lightweight aluminum wire to maintain the agility to reproduce high frequencies while its large diameter and fiberglass former assures extremely high thermal power handling.

Treated Kevlar fiber cones are used because of their combination of low weight, high stiffness and resistance to resonances. The 408 and 508GTi Woofer/Midranges are topped off with a treated fabric inverted dome for smooth reproduction of upper midrange frequencies.

The cone motion of these high excursion designs is controlled by a Aromatic Polyamid Fiber Spider. This new material is able to control the 0.6" motion of the cone while maintaining musical

accuracy because it is 3 times stronger than conventional spider materials.

The tweeters in the 408 and 508GTi feature domes made from pure titanium. Pure titanium has long been known to have a very high stiffness to weight ratio, making it ideal for treble reproduction. However, only JBL has "tamed" titanium through a special manufacturing process. The dome of the 408 and 508GTi Tweeter is created using special nitrogen gas cooled forming machines which can create a uniformly paper-thin dome without the work-hardening or deformation which causes resonances in domes made without benefit of this process

Equally important is the 408 and 508GTi crossover design. Each crossover was meticulously optimized in JBL's state-of-the-art acoustic laboratory to guarantee a seamless blend of the woofer/midrange and tweeter output. Unlike generic or general purpose crossovers, the design of the 408 and 508GTi Crossovers was performed with a full knowledge of the performance characteristics of each driver, allowing frequency, phase, and power

response to be completely optimized for each combination.

What does all this technology add up to? A system with ideal frequency response, excellent off axis response, and high output capability all in a small and elegant package. The result is exceptionally smooth and detailed music reproduction over the full range of frequencies and clean sound that cuts through road noise.

Designing Your System

The overall quality of any system design is a result of how well all of the components work together, not just the result of the performance of any one component. JBL GTi Series woofer/midbass or subwoofer transducers are the ideal companion products to your 408 and 508GTi systems. Each of the GTi Competition Series products are designed to complement the others to provide the highest performance with the simplest and most predictable system design. To use the 408 and 508GTi as the woofer/midrange

and high frequency transducers in a high quality system, we recommend you use either a high quality active crossover such as JBL's GTX47, GTX4 or GTX2 to provide optimum matching to your subwoofer or woofer/midbass loudspeaker. If you prefer passive crossovers, we recommend that you use only high quality audiophile grade film-type capacitors and Low DCR inductors to get the most out of your system. The most popular system configuration is a hybrid using an active crossover for the subwoofer to woofer/midrange crossover point, and a passive crossover for the woofer/midrange to tweeter crossover. Your GTi Competition Series Dealer is uniquely qualified to help guide you on the best system configuration for your needs.

Component Placement

The location of each of the loudspeakers plays a vital role in achieving proper frequency response and spacious imaging. Because the 408 and 508GTi systems have an extremely wide and

smooth dispersion pattern, excellent performance may be achieved in any vehicle. Due to the wide variety of vehicles, there is not one "right" way to locate the 408 and 508GTi, however knowledge of the following considerations will help you get the most from your system:

1. The most spacious stereo image is achieved when the speakers are placed as wide apart as possible.
2. The best center image will be achieved when the distance from the left speaker to your left ear is as equal as possible to the distance from the right speaker to your right ear. This is most easily achieved by placing the 408 or 508GTi as far forward as you can.
3. The best system integration is achieved when the woofer/midrange is mounted close to the tweeter. Installing the tweeter close to the woofer/midrange helps smooth the transition from woofer/midrange to tweeter at the crossover point.
4. You will get the best frequency response when the path from the speakers to your ear is unobstructed.

5. Because of the high acoustic energy capability of the 408 and 508GTi, the woofer/midrange drivers must be securely mounted in a rigid panel which is free from resonances, rattles and air leakage.

Installation Warnings and Tips

- Be careful not to cut or drill into fuel tanks, fuel lines, brake or hydraulic lines, vacuum lines or electrical wiring when working on your vehicle. Inspect behind panels before you cut or drill.
- Be sure to check for clearance of window, cranks and linkages when mounting speakers in door panels.
- Do not use the speakers unmounted. Failure to securely mount this product could result in damage or injury, particularly in the event of an accident.
- Although the materials used on the 408 and 508GTi are inherently water resistant, do not mount the speakers where they will get wet.
- Always disconnect the ground wire from the battery before doing any work on the vehicle.

Mounting Instructions

Pick a mounting location after reading the recommendations in the Component Placement section of this manual.

Installing the GTi System Crossover

The GTi system crossover should be mounted securely to prevent damage to the crossover or possible loosening of wiring connections. Choose one of the crossover mounting methods and follow the directions below:

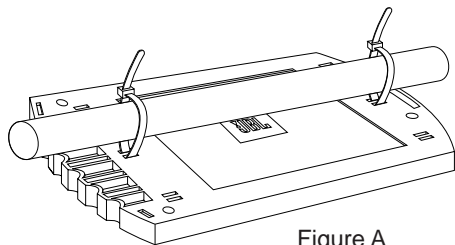

Figure A

Mounting the GTi Crossover with Wire Ties

1. Remove the crossover cover as shown in Figure L.

2. Remove the crossover board from the plastic case.
3. Use wire ties to secure the plastic case to the desired location as shown in Figure A.
4. Cut off the excess plastic on the wire ties.
5. Re-install the PCB and install wiring from the crossover to the amplifier and speaker locations as shown in Figure K.
6. Re-install the crossover cover.

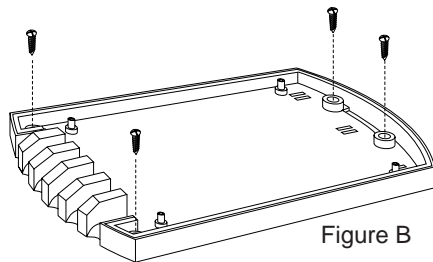

Figure B

Mounting the GTi Crossover with Screws

1. Remove the crossover cover as shown in Figure L.
2. Remove the crossover board from the plastic case.

3. Mark 4 hole locations, drill holes and secure the bottom cover to the desired mounting location as shown in Figure B. Before starting make sure no electrical or other critical car components are located where you will be drilling.
4. Re-install the PCB and install wiring from the crossover to the amplifier and speaker locations as shown in Figure K.
5. Re-install the crossover cover.

Note: Do not mount the GTi Crossover in a location where it can get wet, as this may cause damage to its components.

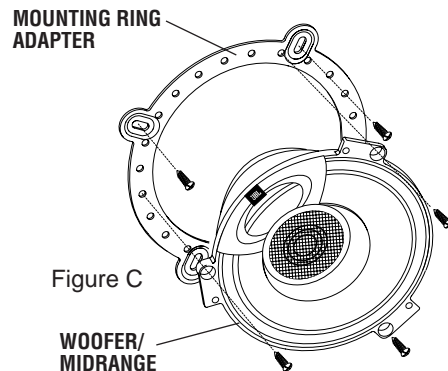

Figure C

Woofer/Midrange Driver Mounting

Mounting the Woofer/Midrange to Stock Hole Locations

1. Access the stock speaker location and remove the stock speaker. The 408 and 508GTi include mounting ring adapters which allow the speaker to be mounted in standard 4" and 5 1/4" holes respectively.
2. Attach the mounting ring adapter to the stock location using four #8 x 1 1/4" screws as shown in Figure C.
3. Attach the foam gasket to the back of the woofer/midrange. Connect the speaker wire from the crossover terminals marked "W" to the speaker by either soldering (preferred) or using crimp terminals. Connect the wire from the "W+" terminal on the crossover to the red "W" terminal on the woofer/midrange. Repeat the same process for the "W-" terminal (see Figure K for details).
4. Mount the woofer/midrange driver to the adapter ring using three #8 x 5/8" screws and three shoulder washers as shown in Figure C.
5. Replace the stock speaker panels.

Mounting the Woofer/Midrange in Custom Locations

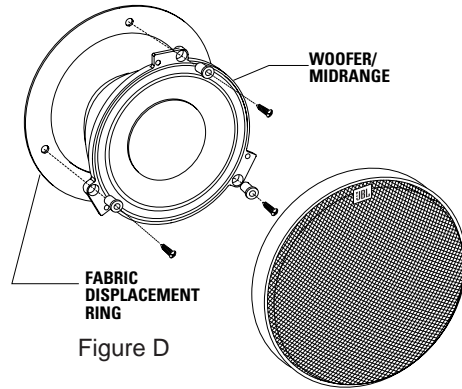

1. Snap the grille assembly of the speaker onto the driver and choose three hole locations so that the grille logo is oriented as desired for your installation. Use the Fabric Displacement Ring included in the package to mark the location of the three screw holes and the speaker cutout holes (cutout hole sizes are listed in the Specifications section). Before cutting or drilling make sure that there are no car components, electrical wiring or any other items that could be damaged.

2. Cut out the speaker hole at the mounting location and drill the three marked holes with a 1/8" (3mm) drill.
3. Run speaker wire to the hole location, making sure that either an active or the included passive crossover is connected to the speaker (see Figure K for wiring details).
4. Put the speaker Fabric Displacement Ring under the speaker as shown in Figure D.
5. Attach the foam gasket to the back of the woofer/midrange. Connect the speaker wire from the crossover terminals marked "W" to the speaker by either soldering (preferred) or using crimp terminals. Connect the wire from the "W+" terminal on the crossover to the red "W" terminal on the woofer/ midrange. Repeat the same process for the "W-" terminal (see Figure K for details).
6. Mount the speaker to the hole location using three #8 x 1 1/4" screws and three shoulder washers as shown in Figure D.
7. Push the grille down onto the speaker making sure the tabs on the speaker match with the slots in the grille. Twist the grille about 1/2" (12mm) clockwise to lock the grille into place.

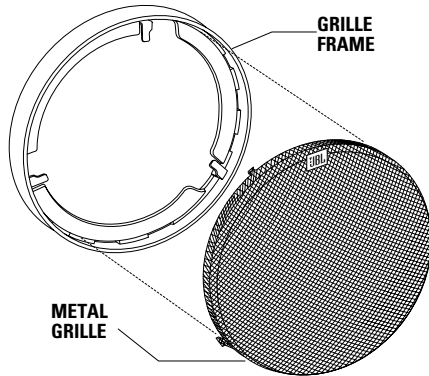

Figure E

Note: The metal grille is designed so that it can be covered with grille cloth if desired. Simply, remove the metal grille from the grille frame as shown in Figure E. Then use spray adhesive to glue and wrap the grille cloth to the metal grille. Push the metal grille with cloth back in the grille frame. For even better interior matching it is also possible to use plastic compatible paint to match the grille frame to the vehicle's interior.

Logo Orientation on Grille

The orientation of the logo on the metal grille relative to the grille frame can be adjusted. Simply remove the metal grille and reassemble the metal grille to the grille frame utilizing a different tab slot.

Mounting the 408 and 508GTi Tweeter

The 408 and 508GTi Tweeter includes accessories for four different mounting configurations. Take a look at all the possibilities described in the following paragraphs, pick one, follow the steps and you'll soon be done!

Tweeter Surface Mounting Instructions

a) Using the Mounting Plate Template at the back of this manual. Pick a mounting location for the tweeter making sure that speaker wire can be run to this location. Flat surfaces work best. Drill the holes as shown on the template in the desired mounting location. Use three $\frac{3}{8}$ "

mounting screws to secure the mounting plate in place as shown in Figure F.

b) Run wire from the 408 and 508GTi Crossover to the wire feed-through hole and connect the wire to the tweeter making sure to connect + to + and - to - by either soldering (preferred) or using crimp-on connectors.

c) Push the tweeter down onto the mounting plate making sure to line up the bayonet tabs with the slots in the tweeter housing.

d) Twist the tweeter clockwise about $\frac{1}{4}$ " to lock it into position.

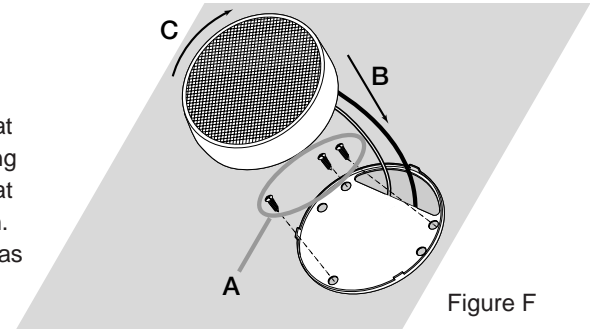

Figure F

TWEETER SURFACE MOUNT INSTALLATION

Tweeter Surface Angle Mounting Instructions

- a) Using the Surface Angle Mount Template at the back of the manual, drill two screw holes at the desired mounting location, making sure to choose the correct tweeter orientation. Secure the Surface Angle Mount Adapter with two $\frac{3}{4}$ " sheet metal screws as shown in Figure G.
- b) Secure the mounting plate to surface angle mount adapter using two $\frac{5}{16}$ " screws.
- c) Run the speaker wire from the 408 and 508GTi Crossover to the wire through hole and connect the wire to the tweeter making sure to connect + to + and - to - by either soldering (preferred) or using crimp-on connectors.
- d) Push the tweeter down onto the mounting plate making sure to line up the bayonet tabs with the slots in the tweeter housing.
- e) Twist the tweeter clockwise about $\frac{1}{4}$ " to lock it into position.

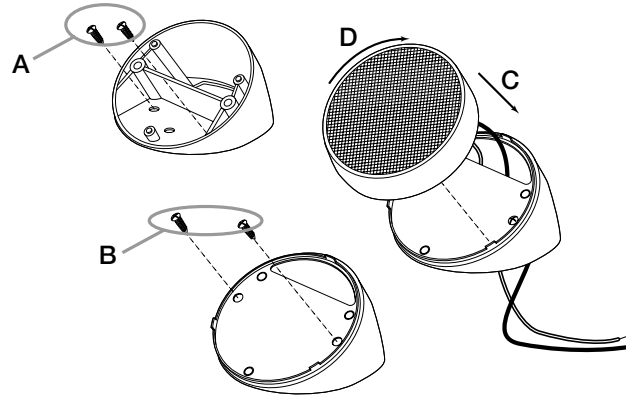

Figure G

TWEETER SURFACE ANGLE INSTALLATION

Tweeter Flush Mounting Instructions

a) Use a hole saw or other tool and the Flush Mount Template at the back of this manual to make a hole for the flush mount cup in the desired location. Secure the metal spring to the Flush Mount Cup using one metal spring screw as shown in Figure H. Tighten the screw only enough to keep the metal spring from falling off.

b) Push the Flush Mount Cup with the metal spring into the hole that was cut in step a.

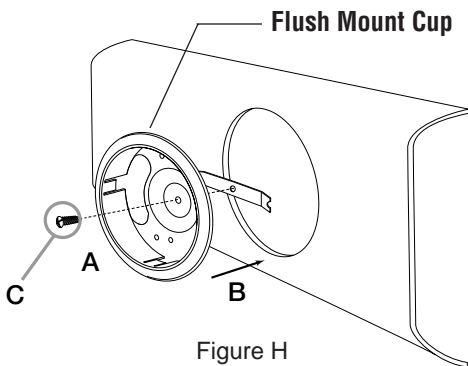

FLUSH MOUNT INSTALLATION

c) Tighten the larger $\frac{3}{4}$ " spring mounting screw to lock the Flush Mounting Cup into the mounting hole.

d) Secure the mounting plate to the Flush Mount Cup using three $\frac{5}{16}$ " screws. Connect the speaker wire from the crossover to the tweeter (see Figures I and K), making sure to observe correct polarity.

e) Push the tweeter down onto the mounting plate making sure to line up the bayonet tabs with the slots in the tweeter housing.

f) Twist the tweeter clockwise about $\frac{1}{4}$ " to lock it into position.

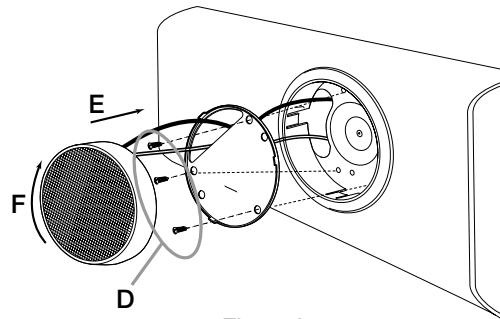

TWEETER FLUSH MOUNT INSTALLATION

Tweeter Flush Angle Mounting Instructions

- a) Follow steps a through c in the Tweeter Flush Mounting Instructions.
- b) Secure the Flush Angle Mount Adapter to the Flush Mount Cup using two $\frac{5}{16}$ " screws as shown in Figure J.
- c) Connect the 408 and 508GTi speaker wires (from the crossover) to the tweeter, observing correct polarity (see figure K for details).
- d) Press the tweeter down onto the Flush Angle Mount Adapter lower portion, making sure to line up the snaps with the slots in the tweeter housing.
- e) Snap the other portion of the tweeter down onto the angle adapter.

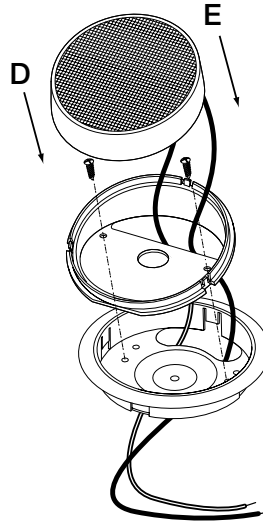

Figure J

TWEETER FLUSH ANGLE INSTALLATION

Wiring

Use 2-conductor stranded type, insulated wire to connect the 408 and 508GTi Woofer/Midrange and tweeter to the included crossover, and the crossover to the amplifier as shown in Figure K.

A minimum wire gauge of 18AWG is recommended, with larger size suggested for wire runs longer than 10 feet.

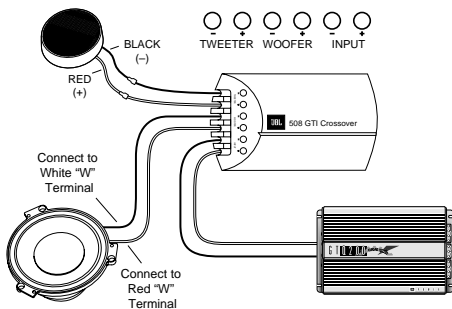

Figure K

The polarity (the positive / negative orientation of the connections) for every speaker and crossover to amplifier connection must be consistent from left to right channel to assure proper imaging and optimum frequency response. This does not mean that the woofer/midrange should always be connected in the same polarity as the tweeter however. It is possible, that due to the difference in the distance the sound travels from the woofer/midrange to your ears compared to the distance from the tweeters in a typical system, and the short wavelengths of sound at the crossover frequency, that a connection where the tweeters are connected in reverse polarity from the woofer/midrange drivers may actually result in better sound. Because there is no way to accurately predict this before installation, we recommend that you try the connection both ways, and leave it in the polarity that gives the smoothest audible transition between the woofer/midrange and tweeter. When the tweeter and woofer/midrange drivers are mounted close to each other, the in-phase connection will usually yield the best sound.

Crossover Tweeter Level Adjustment

The Gti System Crossover allows you to adjust the level of the GTi Systems Tweeter. This adjustment is located under the crossover cover. To remove this cover simply press on the end of the cover (as shown in Figure L) and lift off. The adjustment of the tweeter level is done by setting the switch on the crossover (see Figure M) to the “0dB,” “-2dB” or “-4dB” position. Set this switch in the position that matches your personal preference. Both crossovers should have this switch set in the same position.

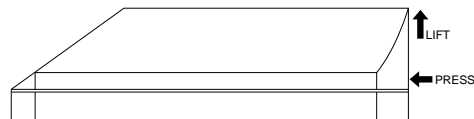

Figure L

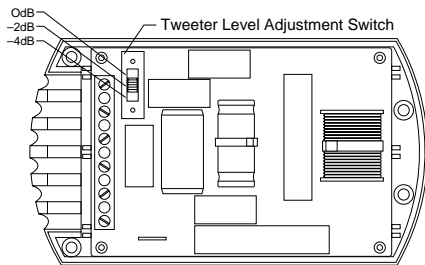

Figure M

System Connections

There are a variety of system options available with the 408 and 508GTi. The simplest configuration is to use the 408 and 508GTi full range. Although this will yield good sound, the best performance will be achieved in a high-end system which includes subwoofers and, optionally, midbass transducers. Because the 408 and 508GTi are specifically designed for mid and high frequency operation, they should have their extremely low frequencies blocked by electrical means in order to achieve the best system fidelity and the widest dynamic range. Full range

use may be obtained at slightly lower power handling levels.

For the best performance, we recommend that an active crossover with a minimum of 12dB per octave slope be used for the transition point between the Subwoofer and the 408 or 508GTi. The optimum crossover frequency for this transition is dependent on the specific components used, the vehicle, and other installation details. As a general rule, the crossover frequency should be as low as possible to achieve the best system imaging. You can fine-tune the crossover after the installation is complete for the best sound. A good place to start your tuning process is between 60Hz and 150Hz when using the 508GTi and between 80Hz and 150Hz when using the 408GTi. In 4-way systems using a midbass driver such as the 600GTi, the crossover point may be raised higher without detrimentally affecting imaging as long as the woofer/midbass drivers can be mounted reasonably close to the woofer/midranges. This higher crossover frequency will allow the system to play

louder. Since no crossover is perfect, it is advisable to keep your crossover points away from the range where your hearing is most sensitive. Therefore we recommend that you try to keep the high-pass frequency below 250Hz. This lets the 408 or 508GTi reproduce the entire range of frequencies covering the most important vocal and lead instrument fundamentals and their harmonics.

If you prefer to use all passive crossovers, you will need to construct or purchase a high-pass filter for the subwoofer to woofer/midrange transition point and install it in-line ahead of the 408 or 508GTi Crossover. For the best system dynamic range, we recommend that a minimum slope of 12dB per octave be used.

The most advanced system designs use active electronic crossovers such as the JBL GTX2, GTX4 or GTX47 at both the subwoofer (or woofer/midbass)-to-woofer/midrange transition point and at the woofer/midrange-to-tweeter transition. Set the high crossover frequency at or above 5kHz if a 12dB per octave crossover is

used and at or above 3.5kHz if you are using an 18 or 24dB per octave crossover. In this configuration, the crossovers supplied with the 408 and 508GTi are not used. For tweeter protection, a 1.5A fast acting fuse should be installed in series with the tweeter. The maximum recommended RMS amplifier power routed directly to the woofer/midrange is 150 watts for the 408GTi and 200 watts for the 508GTi. The maximum recommended RMS amplifier power routed directly to the tweeter is 125 watts.

Speaker Break-In

The 408 and 508GTi Woofer/Midranges use many high strength materials which require a break-in period before they will achieve top performance. The drivers need to be broken in at a medium volume level for about 1 hour before maximum performance is achieved.

A Note on Power Handling

As a result of their high efficiency, all

JBL loudspeakers will produce reasonable volume levels in the automotive environment using very little amplifier power. However, the use of a low-powered amplifier to attain very high volume levels could lead to overdriving the amplifier. This will generate high distortion levels which can easily damage loudspeakers, *even if the rated power of the amplifier is below the rated maximum power handling of the loudspeaker!*

As a general rule, do not turn up the volume control past the point where you hear distortion in the form of either signal distortion from an overdriven amplifier or mechanical noise from an overstressed speaker. *For the best performance and system reliability, you should select an amplifier with an output rating greater than the maximum power likely to be used to generate the desired volume levels.* If you want your system “Loud + Clear,” we suggest that you step up to a JBL power amplifier which has an RMS power rating equal to, but not exceeding, the *Maximum Recommended Amplifier Power* listed in the specifications of your specific JBL

speaker. This margin of reserve power will ensure that the amplifier will not attempt to deliver more power than its design allows. Your dealer will be happy to point out which high power JBL amplifiers are optimum for your application and listening habits.

Following these guidelines will provide virtually distortion free sound reproduction and long loudspeaker life.

In Case of Difficulty

The most common difficulties are noise, distortion, and intermittent connections.

System noise is usually not the fault of the 408 and 508GTi. Hiss or “alternator whine” is most often the result of faulty grounding of the system electronics or improper setting of amplifier level controls. An exception to this is if the passive crossover networks are mounted near a source of radiated noise, the network may pick up this noise with sufficient power to drive the 408 and 508GTi. For this reason, be careful not to mount any passive

crossovers near wires carrying high currents such as battery cables or wires leading to ammeters or tachometers.

Distortion is usually the result of overdriving one or more components in the system. The problem is most likely insufficient amplifier power, or improper setting of gain controls. Refer to the instructions which came with the electronics for assistance. The 408 and 508GTi will not play as loudly, or handle the full rated power, when used without a subwoofer and associated high-pass crossover. When using the 408 or 508GTi full-range, be careful to limit the volume level to that which can be reproduced without audible distortion from the speaker.

If you want to talk to us about any problems, call JBL Customer Service at 1-800-336-4JBL (4525) between 9AM and 5PM eastern time.

Specifications:	408GTi	508GTi
Frequency response:	80–22kHz	60–22kHz
Recommended minimum High-Pass Crossover Frequency for Medium Power Operation:	80Hz	60Hz
Continuous Power Handling With 12dB Passive Network High Passed at Recommended Minimum Frequency:	100 Watts	150 Watts
Continuous Power Handling with 12dB Passive Network High Passed at 150–200Hz (Midrange Operation):	150 Watts	200 Watts
Continuous Power Handling When Used Without High-Pass (Full-Range Operation):	75 Watts	100 Watts
Minimum Recommended Amplifier Power:	20 Watts	20 Watts
Maximum Recommended Amplifier Power Rating:	150 Watts	200 Watts
Sensitivity (2.83 Volts / 1 Meter):	89dB	91dB
Impedance	4 Ohms	4 Ohms
Dimensions – Woofer/Midrange Transducers		
Overall Maximum Diameter (Mounting Tab to Frame Edge):	4 ³ / ₈ " (111mm)	5 ¹ / ₈ " (130mm)
Height:	2 ¹ / ₈ " (54mm)	2 ³ / ₈ " (60mm)
Mounting Depth:	1 ⁷ / ₈ " (48mm)	2 ¹ / ₁₆ " (53mm)
Cutout Size:	3 ³ / ₄ " (95mm)	4 ³ / ₄ " (121mm)
Dimensions – Tweeter		
Overall Diameter:	1 ¹⁵ / ₁₆ " (50mm)	1 ¹⁵ / ₁₆ " (50mm)
Height:	1 ¹ / ₁₆ " (18mm)	1 ¹ / ₁₆ " (18mm)
Height With Angle Adapter:	1 ¹ / ₂ " (38mm)	1 ¹ / ₂ " (38mm)
Flush Mount Cutout Diameter:	2 ¹ / ₈ " (54mm)	2 ¹ / ₈ " (54mm)
Flush Mount Depth:	1 ⁵ / ₁₆ " (23mm)	1 ⁵ / ₁₆ " (23mm)
Dimensions – Crossover Network (LxWxH):	5 ¹⁰ / ₁₆ " x 3 ³ / ₁₆ " x 1 ⁹ / ₁₆ " (143mm x 81mm x 40mm)	5 ¹⁰ / ₁₆ " x 3 ³ / ₁₆ " x 1 ⁹ / ₁₆ " (143mm x 81mm x 40mm)
Woofer/Midrange Weight:	1 lb. 7 oz. (0.66kg)	1 lb. 10 oz. (0.75kg)
Tweeter Weight:	2.5 oz. (71 grams)	2.5 oz. (71 grams)

Thiele-Small Specifications:	408 GTi	508 GTi
Free Air Resonance (Fs):	125Hz	100Hz
Electrical Damping (Qes):	0.52	0.51
Mechanical Damping (Qms):	5.17	5.14
Total Damping (Qt):	0.47	0.4
Equivalent Volume of Compliance (Vas):	0.0388 cu. ft. (1.10 liters)	0.1059 cu. ft. (3.0 liters)
Effective Cone Area (Sd):	9.3 sq. inches (0.0060 m ²)	14.26 sq. inches (0.0092 m ²)
Center to Peak Linear Excursion (Xmax):	0.126 inches (3.2mm)	0.126 inches (3.2mm)
Voice Coil DC Resistance (Re):	3.4 ohms	3.4 ohms
Voice Coil Inductance (Le):	0.22mH @ 1kHz	0.22mH @ 1kHz
Voice Coil Diameter:	2 inches (51mm)	2 inches (51mm)
Voice Coil Length (Winding Length):	0.400 inches (10.2mm)	0.400 inches (10.2mm)
Air Gap Height:	0.200 inches (5.1mm)	0.200 inches (5.1mm)
BL Product:	6.2 T/M	6.2 T/M
Effective Moving Mass (Mm):	0.28 oz. (8.0 grams)	0.32 oz. (9.0 grams)

Note: The Thiele-Small specifications shown apply only after a break-in period of approximately 2 hours.

JBL continually strives to improve its products. New materials, production methods and other refinements may result in a change from published specifications and description. The changes will equal or exceed the original specifications, unless otherwise stated.

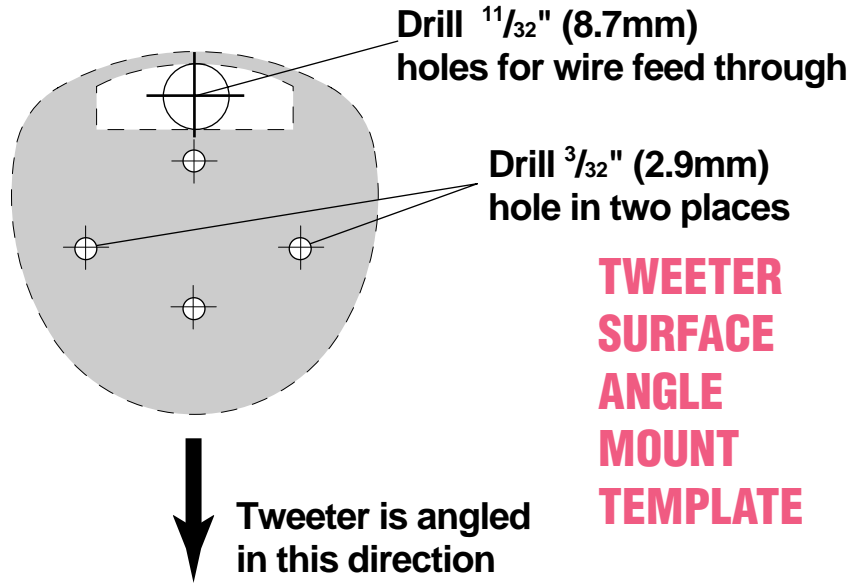

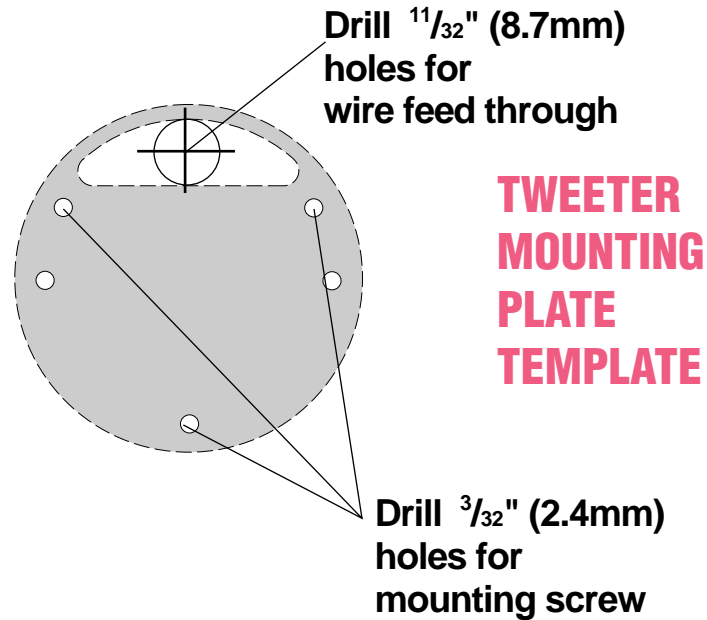

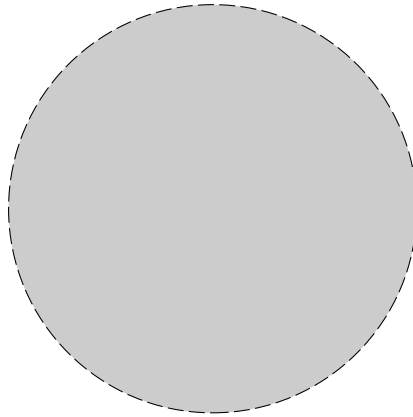

**Cut Hole Using
2¹/₈-2¹/₄" (54mm)
hole saw**

TWEETER FLUSH MOUNT TEMPLATE

JBL Consumer Products, Inc.
80 Crossways Park West
Woodbury, NY 11797
8500 Balboa Blvd.
Northridge, CA 91329
1-800-336-4JBL



H A Harman International Company

Free Manuals Download Website

<http://myh66.com>

<http://usermanuals.us>

<http://www.somanuals.com>

<http://www.4manuals.cc>

<http://www.manual-lib.com>

<http://www.404manual.com>

<http://www.luxmanual.com>

<http://aubethermostatmanual.com>

Golf course search by state

<http://golfingnear.com>

Email search by domain

<http://emailbydomain.com>

Auto manuals search

<http://auto.somanuals.com>

TV manuals search

<http://tv.somanuals.com>