

STEAMPRO™ 120

Steam Generator Installation and Operating Manual

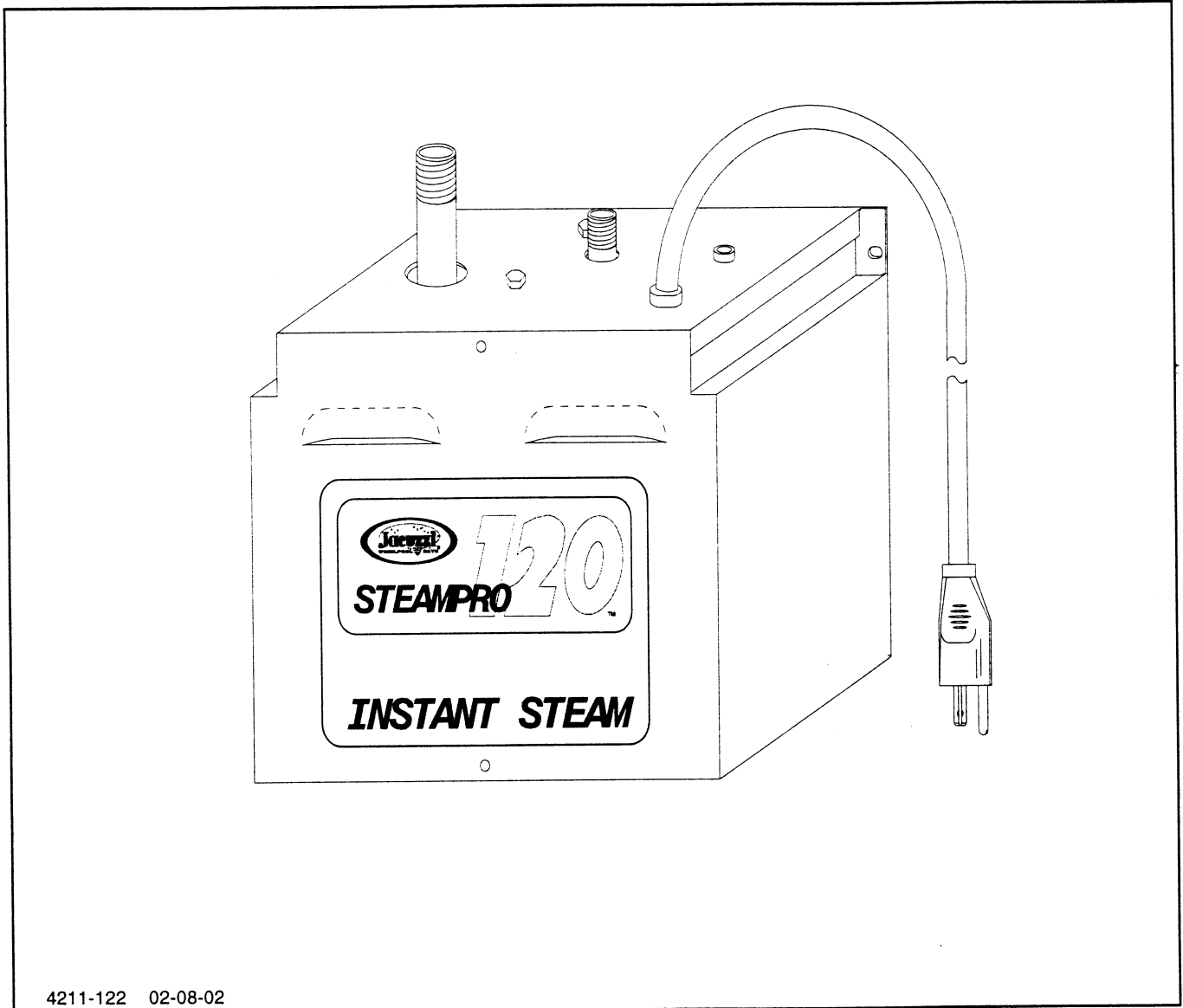

4211-122 02-08-02



IMPORTANT SAFETY INFORMATION

READ ALL INSTALLATION INSTRUCTIONS

Jacuzzi Whirlpool Bath does not recommend prolonged periods of use of the steamer. Prolonged use of the steam system can raise excessively the internal human body temperature and impair the body's ability to regulate its internal temperature (hyperthermia). Consult your physician about your safety and comfort before using the steam system. Limit your use of steam to 10–15 minutes until you are certain of your body's reaction. A cooling shower spray can be used simultaneously with the steam to assist in regulating your body temperature.

Alcohol and certain drugs or medications, such as tranquilizers, affect a person's ability to withstand high temperatures and may produce dangerous side effects. Don't use alcohol or drugs when using steam.

The elderly, the infirm, and children should not use the steamer unattended. Pregnant women and people with heart conditions should consult their physicians before using the steamer.

The wet surfaces of steam enclosures can be slippery. Use care when entering and exiting.

Do not place or use electrically connected devices, such as television, radio, or stereo speakers, lights, hair dryers, or telephones, within 1.5 m (5 feet) of a steam enclosure, shower, or bath.

Read and follow manufacturer's safety information with all optional equipment.

The steam head is hot. Do not touch the steam head or the steam within one foot distance of the head or surfaces surrounding the steam head.

Do not block or obstruct the steam head in any manner.

Do not store or use flammable liquids near the steam generator.

Electrical grounding is required on all steambath generators.

All electrical supplies should be disconnected when servicing generator.

All wiring must be installed by a licensed electrical contractor in accordance with local and national codes.

All plumbing must be installed by a licensed plumber in accordance with all applicable local and national codes.

SteamPro generators must be installed upright and level.

SteamPro generators are for indoor use only.

SteamPro generators are not for space heating purposes.

Be certain that steambath enclosures are properly sealed to avoid water damage from escaping steam. It is recommended that 100% silicone caulk be used to seal all pipes and fittings. Steam must be prevented from escaping into the wall cavity.

Never shut off the water to a steam generator that is in use.

Save These Instructions for Future Use.

Inspection and Shipping Claim

Check for shipping damage upon receipt of the product. Jacuzzi Whirlpool Bath is not responsible for damage to the product sustained during shipping. If damage is evident before unpacking, see instructions regarding shipping claims on the outside of the carton and immediately file a claim with the carrier.

Once the product has been removed from the carton and before it is permanently installed, check the parts completely for damage resulting from shipping or handling. All Jacuzzi Whirlpool Bath products are factory tested for proper operation and watertight connections prior to shipping. If problems are detected, immediately notify your Jacuzzi Whirlpool Bath dealer or Authorized Service Agent, or call Jacuzzi Whirlpool Bath, 800-363-0251, for Warranty Service.

NOTE: Damage or defects which could have been discovered and repaired prior to installation and which are claimed after final installation of the product are excluded from our warranty.

Owner's Record

Date Purchased _____

Purchased From _____

Installed By _____

Serial Number _____ Model # _____

(The serial number is located on the end of the steam generator)

Contents

Installation of Steam Generator

Electrical Requirements	2
Locating the Steam Generator	3
Room Construction and Ventilation	3
Plumbing Instructions and Cautionary Notes on Installation	4
Control Installation	5
Service	6
Trouble Shooting	8
Wiring Diagram	10

GENERAL DESCRIPTION

The SteamPro™120 steam generator from Jacuzzi Whirlpool Bath is designed in an ultra compact size for easy installation and provides instant steam for convenient steam bathing. The SteamPro 120 must be supplied with 115V 20A electrical service. The generator is designed to be manually drained. **For residential use only in Acrylic or Fiberglass enclosures, rated for Steam.**

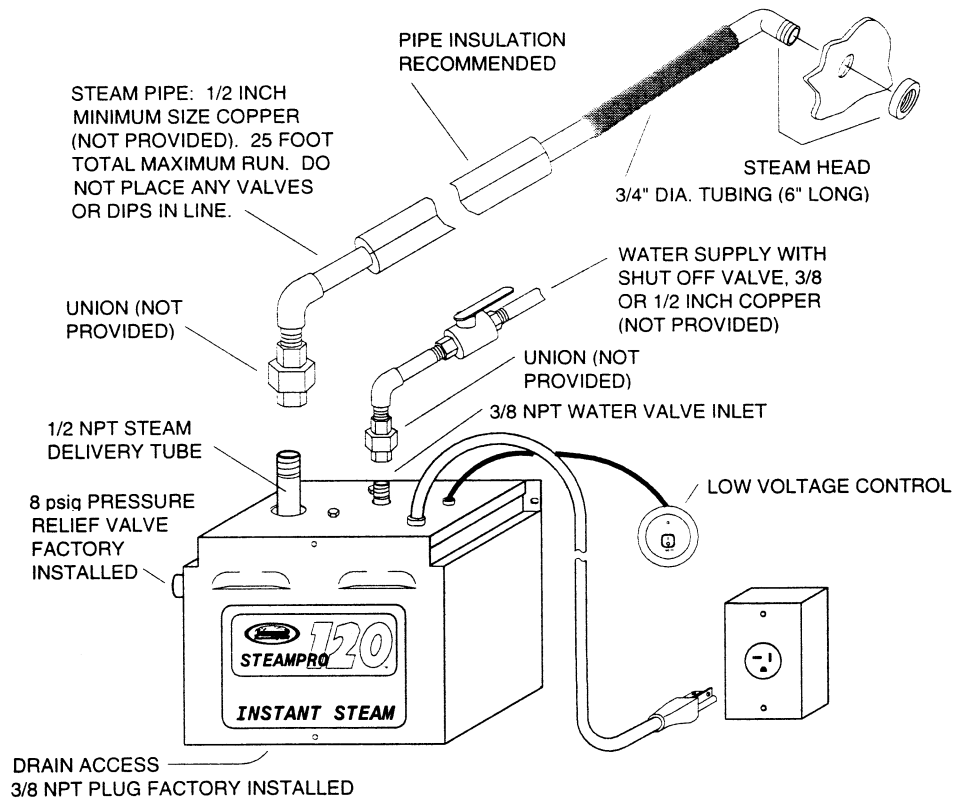

SPECIFICATIONS

MAX. CAPACITY RATING (cubic feet)	AVAILABLE SIZES	MODEL NUMBER	DIMENSIONS LxWxH	DRY WEIGHT	WEIGHT FILLED WITH WATER	PACKAGED SHIPPING WEIGHT
80	2kW	T632000	9-1/4" x 4"x 7-1/2"	2.5 lbs. (1.1 kg)	3 lbs. (1.4 kg)	3 lbs. (1.4 kg)

INSTALLATION

Electrical Requirements

The SteamPro 120 operates at 115 VAC at 50 or 60 Hz. Circuit is to be single phase 3-wire GFCI protected (one conductor at line voltage, one neutral conductor and one ground conductor must be provided). Check your local building code for requirements. Note that the line cord from the SteamPro 120 is equipped with a plug designed for a 20 AMP receptacle; do not modify the plug in any way. A 20 AMP dedicated receptacle and wiring must be furnished for a proper installation.

Caution: Without proper grounding protection, a system malfunction may cause fatal shock.

INSTALLATION

Locating the Steam Generator

The steam generator must be installed **upright and level**. The steam generator must be located within a 12 foot maximum steam line run to the steam head **AND** within the 25 foot control wire length to the control. It may stand attached to a horizontal base or to a wall. Provide for draining from the drain located at the bottom of the generator. For wall mounting, use slots on cabinet and install a wood cleat or shelf to the wall at the bottom of the unit to help support the bottom. Install the steam generator indoors only and in a dry location that will not be subject to freezing. If exposure to freezing can not be avoided (e.g., seasonal-use homes) turn off the water supply to the unit and drain the tank. Turn off the water supply to the unit if it will not be used for an extended period of time.

Room Construction and Ventilation: Important

The steam room must be constructed of Acrylic or Fiberglass rated for steam that can withstand excessive amounts of moisture and condensation. Large amounts of steam can be released into the room when the enclosure door is opened. Providing natural or forced ventilation outside of the enclosure will help minimize moisture damage to the building. Jacuzzi Whirlpool Bath is not responsible for damage resulting from excessive moisture. Consult an architect or engineer for aid in designing the structure of your room.

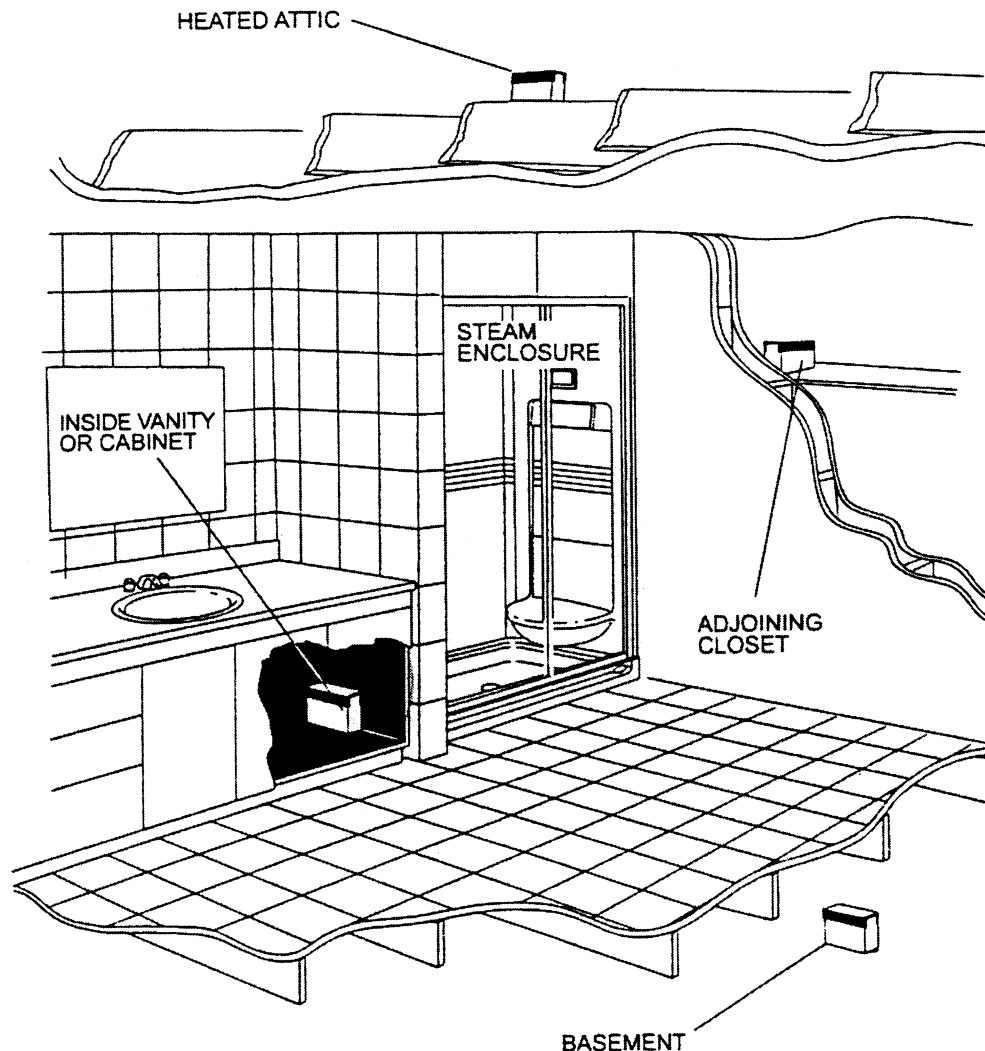

INSTALLATION

Plumbing Instructions and Cautionary Notes on Installation

Minerals in the water or poor water quality can shorten the life of the steam generator or cause erratic operation if the tank is not drained regularly. Drain the tank frequently.

Guard against possible contact with hot steam pipes and other plumbing.

Maximum run of the steam pipe is 12 feet. The steam pipe should be insulated. This will reduce condensation in the steam line and will increase efficiency. Use copper and brass pipe and fittings, 1/2 inch minimum, or 3/4" silicone hose with protective cover.

Install a **water supply shutoff valve** where it is easily accessible.

The water supply pipe should be attached to cold supply. Do not use a saddle or piercing type connection for the steam unit water supply.

Apply thread compound sparingly to fitting threads such that excess compound does not dislodge and restrict the copper pipes or water valve. Flush lines before making connections to the generator.

When tightening or loosening fittings, **always use a backup wrench to hold the adjacent fitting.**

Caution: Do not install any valves or create restrictions in the steam line. **Do not construct any dips or valleys in the steam line** as condensation will accumulate in these and block the pipe with water. Pitch the steam line such that condensation will run to the steam generator (preferable) or to the steam head.

INSTALLATION

A. STEAM CONTROL BY 30 MINUTE LOW VOLTAGE ON/OFF CONTROL.

1. Control cable rough-in:

The low voltage control can be mounted **up to 75 feet** from the generator either inside or outside the steam room. (A 25' cable is provided.) String (3) 18 to 22 AWG solid wires from the control location through 1/2" holes in the wall studs or ceiling joists to the generator.

Note: 1) Do not staple through or damage wires,
2) Label or color code wires for proper TB1 to control orientation. See diagram.

2. Control cable at the generator

Route control wires through the generator CONTROL WIRING ENTRY and appropriate strain relief. Connect 3 wires to terminal block TB-1 on the printed circuit assembly, as shown in diagram.

3. Install generator control (R30i)

The low voltage control can be mounted directly to a finished wall either inside or outside the steam room. Using a 1-3/4" hole saw, drill a hole in the finished wall where the control is to be mounted (the control wires should already be roughed-in to this location). Locate the control wires, pull them out through the 1-3/4" hole and plug the 3 wires into the connector on the back of the control housing, as shown in diagram. Run a bead of 100% silicone caulk around the perimeter on the back of the control housing. See diagram. Insert the control into the wall cavity.

THIS LOW VOLTAGE CONTROL CAN BE LOCATED **INSIDE OR OUTSIDE** THE STEAM ENCLOSURE

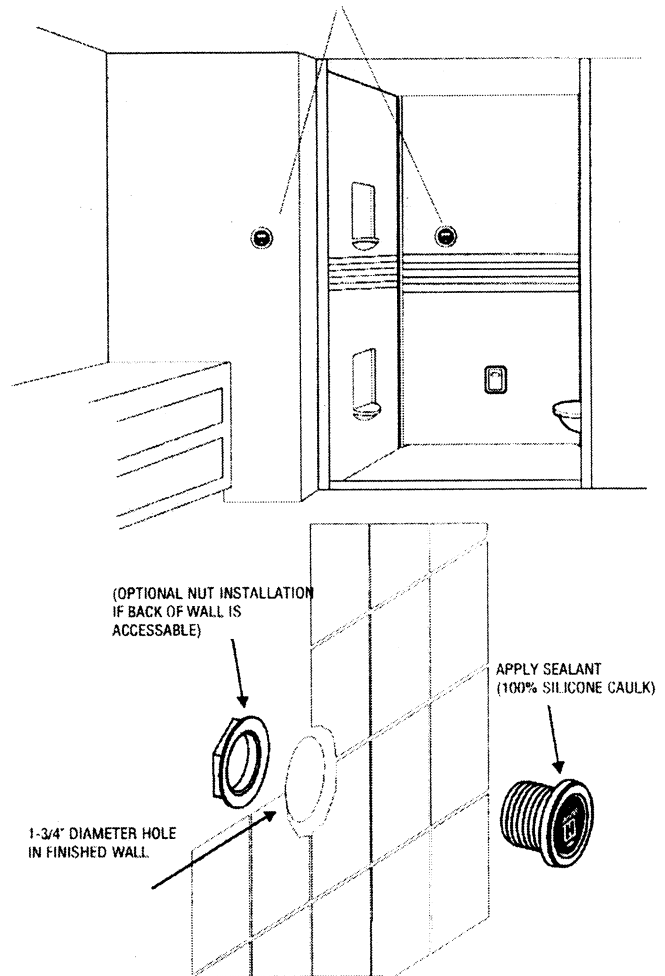

To prepare steam generator:

1. Make certain that **power is disconnected**. Remove cover.
2. Feed wire through hole **A** and connect to **TB1** on the circuit board.
3. Locate strain relief bushing 4" from stripped end of cable jacket with the two connectors. Snap strain relief bushing **B** into hole **A**.
4. Replace cover.

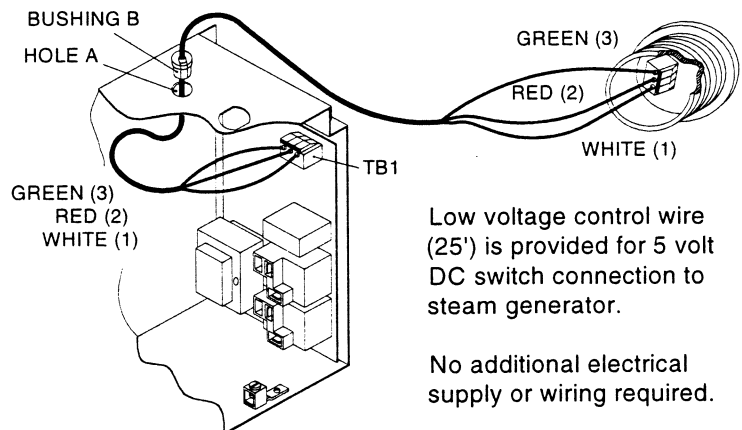

Low voltage control wire (25') is provided for 5 volt DC switch connection to steam generator.

No additional electrical supply or wiring required.

SERVICE

Description of SteamPro Steam Generator

The SteamPro series generator is the latest in modern steam generator design. The SteamPro steam generator uses a printed circuit assembly to monitor and control all the equipment needed to produce steam. The system has three functions: a timer that controls the length of the steam bath; the operating water level is monitored and controlled; and the heating element is protected by a minimum water level sensor. The element can be removed by removing the tank and unscrewing the element.

Maintenance of SteamPro Generators

Maintenance of the SteamPro generator includes flushing the unit periodically and visually inspecting for water leaks. Whenever the generator is opened all wiring should be inspected for any signs of overheating. All electrical connections should be checked for tightness.

Repair of SteamPro Generators

A. ELEMENT REPLACEMENT: Disconnect power from the unit. Drain the tank. Open the front ACCESS cover. Note the wire connections. See diagram. Loosen the tank and remove the element wires. Using a hot water element socket, remove the element. To install a new element, clean the element port and add a light coat of Rectorseal No. 5 pipe thread compound to the element threads. Insert and hand tighten the element. Notice the element end orientation as shown in diagram. Tighten the element until the orientation is the same as diagram, $\pm 15^\circ$. Reconnect the wiring. Test the unit. Check for leaks at the element. Replace the front cover.

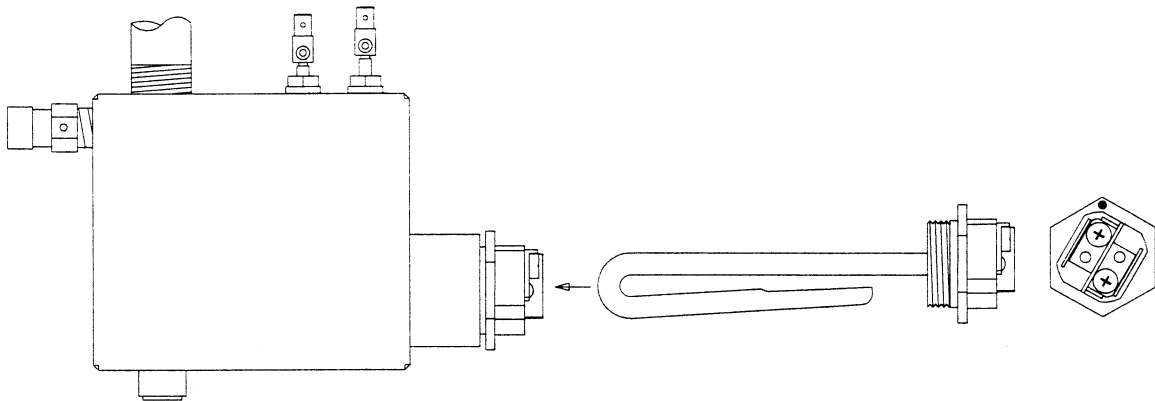

B. PRINTED CIRCUIT REPLACEMENT: Disconnect power from the unit. Remove the front cover. Note where the blue wire is connected to the water level probes. Disconnect the wires from the water level probe. Disconnect the two black wires from the water solenoid and (3) wires connected to TB1. Note and tag the position of all wires that plug into the printed circuit assembly (PCA) mounted relays. Remove and label all the wires from the relays. When removing these wires pull on the connector and not the wire. Four screws through the right side of the unit hold the board in place. Remove all four screws. The printed circuit assembly can now be removed. To install the board reverse this procedure. Test the unit.

IMPORTANT

The blue wire connected to "L" on the PCA must be connected to the highest of the level probes.

SERVICE

- C. WATER SOLENOID REPLACEMENT:** Disconnect power from the unit. Turn the water supply OFF. Disconnect the water supply from the water solenoid valve. Remove the front cover. Remove the two black wires from the water solenoid valve. Use pliers to carefully twist the hose clamp to loosen, then slide it down the hose. Remove the two 1/4" - 20 hex head bolts and lock washers that attach the valve to the chassis. Pull the valve off the rubber fill hose. To install the valve, reverse these instructions. Test the unit.
- D. LEVEL PROBE REPLACEMENT:** Disconnect power from the unit. Remove the front cover. Note where the blue wire is connected to the water level probe. Disconnect the wire from the water level probe. Using a 7/16" box wrench, remove the level probe. Install a new level probe. Place a small amount of thread seal on the top threads of the level probe. Tighten until the bottom of the plastic nut is against the top of the tank. Reattach the wire. Test the unit.

IMPORTANT

The blue wire connected to "L" on the PCA must be connected to the highest of the level probes.

IMPORTANT

The level probe may be extremely tight. Damage to the insulation or chassis may result unless the tank is properly blocked or supported during probe removal or installation. It may be necessary to completely disconnect and disassemble the generator.

TROUBLESHOOTING

There are no user serviceable parts in the Generator. All repair should be performed by a qualified service person. For additional assistance or the factory authorized service person nearest you call the Service Department at 1-800-363-0251. The Trouble Shooting Guide below is meant as a general aid only. Follow ACTION TO BE TAKEN in order until the problem is resolved. Where replacements or repairs are indicated, see the appropriate paragraph of SERVICE SECTION.

SYMPTOMS	PROBABLE CAUSES	ACTION TO BE TAKEN
Control won't turn "ON" (Control light off).	Improper power supplied (no power). Control improperly connected. "PCA" printed circuit assembly is faulty. Control cable is faulty. Control is faulty.	<ol style="list-style-type: none"> 1. a. Make sure circuit breaker is "ON". <li style="padding-left: 20px;">b. Using a voltmeter, check the voltage across the two relays on the "PCA" printed circuit assembly. Voltage should be 115V. <li style="padding-left: 20px;">c. Check fuse on the PCA. If fuse is blown, replace with Buss# MDL 63MA or equivalent fuse. If the fuse blows again - call Service Department. 2. Check control installed per instructions. 3. Replace PCA printed circuit assembly - call Service Department. 4. Replace control cable - call Service Department. 5. Replace the control - call Service Department.
Control "OFF". (Control light off) Water won't shut off and runs out of the steam head.	Water solenoid valve is stuck open. "PCA" printed circuit assembly is faulty.	<ol style="list-style-type: none"> 1. Turn off power to the generator. If the water stops, go to step 3. 2. a. Remove the water solenoid valve, disassemble, clean, re-assemble, and check for proper operation. <li style="padding-left: 20px;">b. Replace valve - call Service Department. 3. Replace the "PCA" printed circuit assembly - call Service Department.
Control "ON". (Control light on) Water won't shut off and runs out of the steam head.	"PCA" printed circuit assembly is faulty. Connection between the blue wire and the water level probe is faulty. Unit improperly grounded. Unit not level.	<ol style="list-style-type: none"> 1. Check that the blue wire is properly attached to the water level probe. 2. Check that the generator is properly grounded. 3. Make sure unit is mounted level. 4. Check the green ground wire to the "PCA" printed circuit assembly. 5. Replace the "PCA" printed circuit assembly - call the Service Department.
Control "ON" (Control light on), Tank drained. Unit won't fill.	No water supplied (turned off?) Plugged water solenoid valve. Water solenoid valve is faulty. "PCA" printed circuit assembly is faulty. Level probe is faulty.	<ol style="list-style-type: none"> 1. Check for proper water supply (Supply valve "on"). Check for closed drain. 2. Remove the blue wire from the level probe. If the unit fills, clean or replace the level probe. 3. Reconnect the blue wire to the level probe. At the water valve solenoid, slide back the wire connectors enough to get the voltmeter probes on the solenoid terminals. Measure the voltage across the solenoid terminals. If it is not 115V replace the printed circuit assembly. If 115V is found proceed with steps 4 & 5. 4. Remove water solenoid valve; disassemble, clean, reassemble, and check for proper operation. 5. Replace the water solenoid valve - call Service Department.

TROUBLESHOOTING

SYMPTOMS	PROBABLE CAUSES	ACTION TO BE TAKEN
Control "ON". (Control light on) Unit won't steam.	Unit has not filled completely. Heating element burnt out. Level probe faulty. "PCA" printed circuit assembly is faulty.	<ol style="list-style-type: none"> 1. Check that blue wire is on High probe and white wire is on Low probe. 2. <ol style="list-style-type: none"> a. Push the control "OFF". b. Remove the drain plug allowing tank to drain completely. c. Replace the drain plug. d. Push the control "ON". e. Unit will begin filling, listen for a click noise. Within 5 seconds after click noise is heard, the water fill will shut off. This will indicate the tank is full. Go to step 3, if the tank does not fill - See SYMPTOMS: "Unit won't fill up". 3. If the tank filled but the relay click was not heard, temporarily ground the white wire/low probe. If the click is heard as probe is grounded, replace the level probe. If the click is not heard replace the "PCA" printed circuit assembly. 4. After it has been determined that the tank has filled and the click noise was heard, use a voltmeter to check the voltage at the element wire's relay connections - the voltage should be 115V. If proper voltage is found call the factory for replacement heating elements. If no voltage is found - check wiring diagram - call Service Department.
Control won't turn "OFF" (Control light off).	Control is faulty.	<ol style="list-style-type: none"> 1. Replace the control - call Service Department.
Control "OFF" Unit won't shut off.	"PCA" printed circuit assembly is faulty.	<ol style="list-style-type: none"> 1. Turn off the power to the generator, replace printed circuit assembly - call Service Department.
Water continually sputters out of steam head.	Foaming contaminants in the water.	<ol style="list-style-type: none"> 1. Flush tank 3 times. 2. Call Service Department.

WIRING DIAGRAM

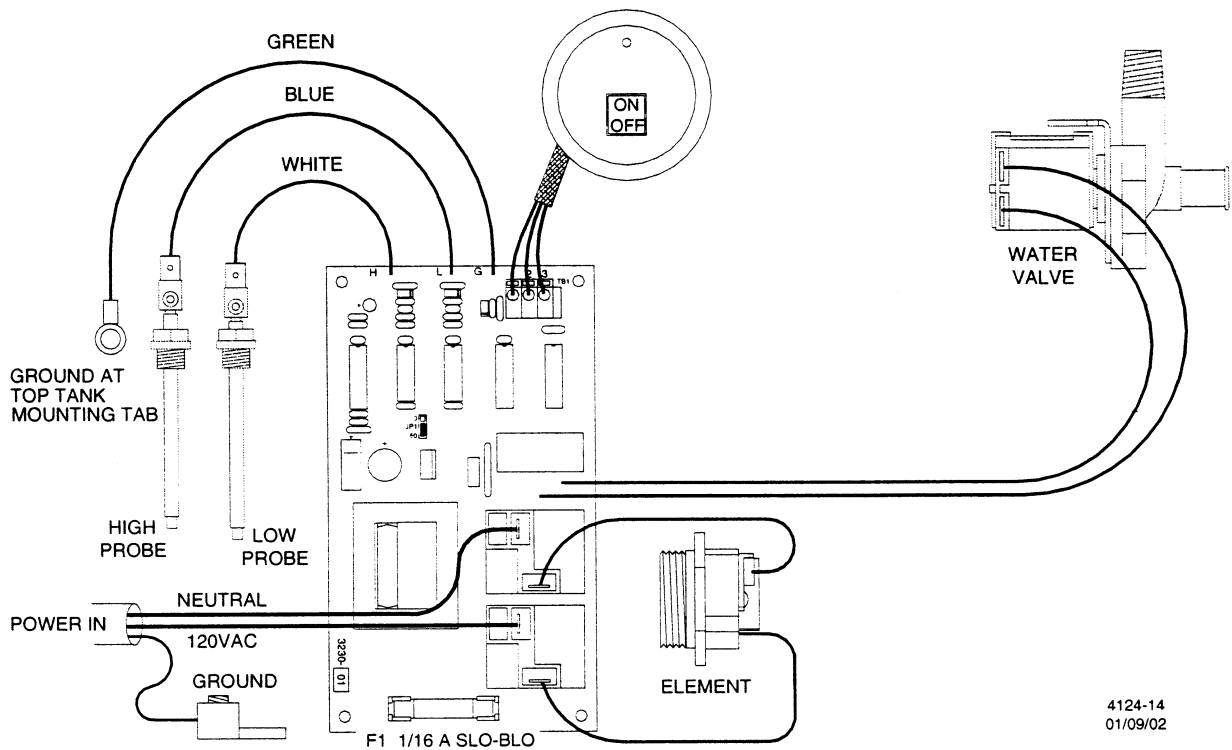

**PRODUCT SPECIFICATIONS ARE SUBJECT TO CHANGE WITHOUT NOTICE.
USE INSTALLATION INSTRUCTIONS SUPPLIED WITH PRODUCT.**

Jacuzzi Whirlpool Bath has obtained applicable code (standards) listings generally available on a national basis for products of this type. It is the responsibility of the installer/owner to determine specific local code compliance prior to installation of the product. Jacuzzi Whirlpool Bath makes no representation or warranty regarding, and will not be responsible for any code compliance.

JACUZZI WHIRLPOOL BATH
Jacuzzi Whirlpool Bath National Headquarters
P.O. Drawer J, Walnut Creek, CA 94596 (510) 938-7070
Service Support: Call (800) 363-0251

©2000 Jacuzzi Whirlpool Bath T985000 02/02

4211-122 02-08-02

JACUZZI WHIRLPOOL BATH LIMITED WARRANTY STEAM GENERATOR PRODUCTS

Jacuzzi Whirlpool Bath, warrants that its Steam Generators (warranted products) are free of manufacturing defects both as to workmanship and material for 5 years and it will replace or repair defective parts or equipment for the period of time and in accordance with the conditions set forth below. The terms of the warranty will be administered by Saunatec Inc. dba, AMEREC.

1. **Applicability.** This warranty applies when the warranted product (a) is installed in accordance with installation instructions provided, (b) is properly and reasonably maintained, and (c) has not been subjected to damage, misuse, or abuse.

2. **Registration.** This warranty becomes valid only after the Limited Warranty Registration form, provided with this warranty, is completely filled in and signed by the original purchaser and mailed to AMEREC within sixty (60) days from the date of original installation. This warranty is non-transferable and shall extend only to the original purchaser.

3. **Duration of Warranty.** AMEREC or its authorized representative will provide parts to replace those with manufacturing or workmanship defects for a period of five (5) years from the date of original installation, except when the warranted product is installed in commercial locations such as clubs, condominiums, apartments, spas or military facilities.

Additionally, for non-commercial locations in the United States AMEREC or its authorized representative will provide reasonable labor to replace defective parts for a period of two (2) years from the date of original installation and three (3) additional years if the product is returned to the factory.

4. **Warranty Work.** All warranty work must be (a) authorized by AMEREC before it is performed; and (b) performed only by authorized AMEREC representatives. This warranty shall not apply to any charges for parts or labor incurred before receiving approval by AMEREC.

5. **Return Authorization Number.** A return authorization number assigned by an AMEREC representative must accompany all returned parts. Parts which are returned without a return authorization number may not be repaired or replaced.

Jacuzzi Whirlpool Bath
C/O AMEREC
P.O. Box 2258
Woodinville WA, 98072

6. Procedure. Requests for repair or replacement, a return authorization number, or warranty information should be directed to AMEREC by calling toll-free 1-800-363-0251 or by writing to AMEREC, 17683 128th Place N.E., Woodinville, WA 98072. Defective product or parts returned for repair or replacement must be shipped prepaid to AMEREC at the above address. Shipping costs for return of replacement product or parts to the purchaser will be at the expense of the purchaser.

7. Limitations, Exclusions, and Remedies. There are no warranties which extend beyond the descriptions on the face hereof. This limited warranty is in lieu of all warranties, expressed or implied, and of all other obligations or liabilities on the part of Jacuzzi Whirlpool Bath. There shall be no implied warranty of merchantability. Jacuzzi Whirlpool Bath neither assumes nor authorizes any person to assume for it any other obligation or liability in connection with the sale of its products.

Damages for breach of this warranty shall not exceed the lesser of the cost of repair or replacement. Repair or replacement shall be the exclusive remedy available to the purchaser.

Under no circumstances shall Jacuzzi Whirlpool Bath be liable by virtue of this warranty or otherwise for any special, indirect, secondary, incidental, or consequential damage of any nature to any person or property arising directly or indirectly out of the use or inability to use a warranted product.

Some States do not allow limitations on how long an implied warranty lasts, or the exclusion or limitation of incidental or consequential damages, so the above limitations and exclusions may not apply to you.

8. Disputes. Any lawsuit alleging breach of this limited warranty shall be commenced within one year from the date of breach. In addition, any such lawsuit may be commenced only in King County, Washington.

This warranty gives you specific legal rights, and you may also have other rights which vary from State to State.



LIMITED WARRANTY REGISTRATION FORM
Please fill out and return within 60 days of installation to:
AMEREC, P.O. Box 2258, Woodinville WA 98072

The undersigned hereby acknowledges the receipt of Jacuzzi Whirlpool Bath Limited Warranty and affirms that the date of installation was _____ 20____, further that installation of the equipment has been completed according to the Jacuzzi Whirlpool Bath installation instructions furnished with the equipment and that I have read, understand and agree to the conditions and terms of the Jacuzzi Whirlpool Bath Limited Warranty in its entirety.

Name of Purchaser _____

Address _____

City _____ **St.** _____ **Zip** _____

Phone _____

Purchaser's Signature _____

Model No. _____ **Serial No.** _____

Free Manuals Download Website

<http://myh66.com>

<http://usermanuals.us>

<http://www.somanuals.com>

<http://www.4manuals.cc>

<http://www.manual-lib.com>

<http://www.404manual.com>

<http://www.luxmanual.com>

<http://aubethermostatmanual.com>

Golf course search by state

<http://golfingnear.com>

Email search by domain

<http://emailbydomain.com>

Auto manuals search

<http://auto.somanuals.com>

TV manuals search

<http://tv.somanuals.com>