



BY APPOINTMENT TO
HER MAJESTY QUEEN ELIZABETH II
MANUFACTURERS OF DAIMLER AND JAGUAR CARS
JAGUAR CARS LIMITED COVENTRY



BY APPOINTMENT TO
HER MAJESTY QUEEN ELIZABETH
THE QUEEN MOTHER
MANUFACTURERS OF DAIMLER AND JAGUAR CARS
JAGUAR CARS LIMITED COVENTRY



BY APPOINTMENT TO
HIS ROYAL HIGHNESS THE PRINCE OF WALES
MANUFACTURERS OF DAIMLER AND JAGUAR CARS
JAGUAR CARS LIMITED COVENTRY

JAGUAR XK8

1998 Range Electrical Guide

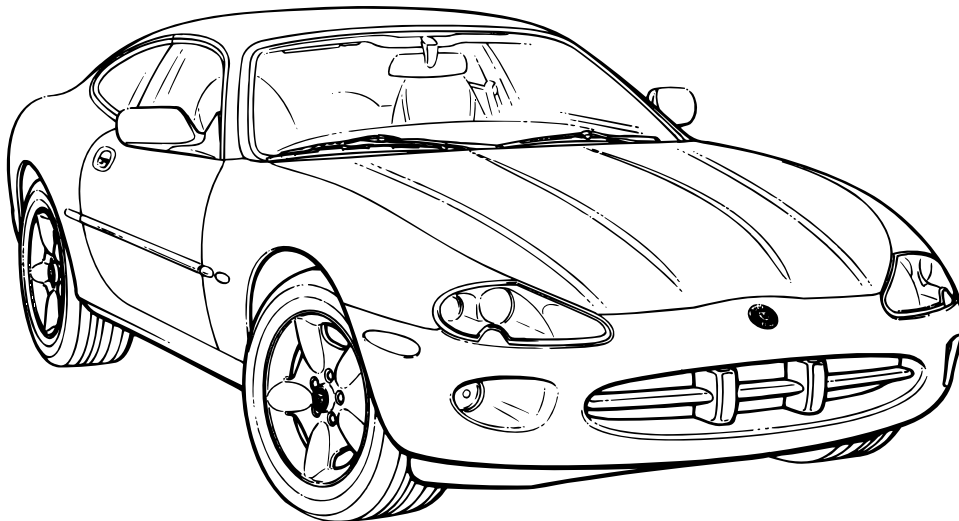

Published by Parts and Service Communications
Jaguar Cars Limited

Publication Part Number – JTP 615





Electrical Guide Format

This Electrical Guide is made up of two major sections. The first section, at the front of the book, provides general information for and about the use of the book, and information and illustrations to aid in the understanding of the XK8 electrical / electronic systems, as well as the location and identification of components.

The second section includes the Figures, which are the basis of the book. Each Figure is identified by a Figure Number (i.e. Fig. 01.1) and Title, and is accompanied by a page of data containing information specific to that Figure.

It is recommended that the user read through the front section of the book to develop a familiarity with the layout of the book and with the system of symbols and abbreviations used. The Table of Contents on the following pages should help to guide the user.

Standard Abbreviations

The following abbreviations are used throughout this Electrical Guide:

B+	Battery Voltage
CAN	Controller Area Network
COUPE	Coupe Vehicles
CONV.	Convertible Vehicles
DI	Direction Indicator
LH	Left-Hand
LHD	Left-Hand Drive
NAS	North American Specification
RH	Right-Hand
RHD	Right-Hand Drive
ROW	Rest of World
SCP	Standard Corporate Protocol Network
VIN	Vehicle Identification Number

Refer to the vehicle Service Manual for a glossary of standard terms and their abbreviations.

Vehicle Identification Numbers (VIN)

VIN ranges are presented throughout the book in the following manner:

→ VIN 123456 indicates "up to VIN 123456"; VIN 123456 → indicates "from VIN 123456 on".

XK8 Electrical System Architecture

The XK8 system "architecture" is new to Jaguar vehicles and features vehicle multiplexing. Multiplexing allows for greatly simplified wiring harnesses, while at the same time allowing flexibility in programming market variants. Two data networks are used in the system: a controller area network (CAN) for the engine, drive train and related systems, and a standard corporate protocol network (SCP) for the body systems. Any vehicle subsystem depicted on the figures with the CAN or SCP included uses data derived from the network, or transmits data via the network to achieve control. Messages for both networks are cataloged in the Appendix of this book. When appropriate, the user will be referred to the Appendix by a note on the Data page. In addition to the two networks, the XK8 uses a serial data bus (ISO) for diagnostics and for the programming of certain control modules.

The XK8 uses both power and logic grounds; however, it does not use a common logic ground stud connection as in previous vehicles.



Component Index	5 – 9
User Instructions	10 – 15
Connectors	16
Main Power Distribution; Ground Point Identification and Location	17
Harness Layout	18
Control Module Identification and Location	19
Control Module Connector Pin Identification and Location	20 – 22
Relay and Fuse Box Identification and Location	23

NOTE: The Appendix, which contains a catalog of CAN and SCP Network messages, follows the Figure and Data pages.



FIGURES

Fig.	Description	Variant
01	Power Distribution	
01.1	Main Power Distribution	All Vehicles
01.2	Battery Power Distribution: Driver and Passenger Fuse Boxes	All Vehicles
01.3	Battery Power Distribution: Trunk, Engine Compartment and EMS Fuse Boxes	All Vehicles
01.4	Ignition Switched Power Distribution	All Vehicles
01.5	Engine Management Switched Power Distribution	All Vehicles
02	Ground Distribution	
02.1	Ignition Switched Ground Distribution	All Vehicles
03	Battery; Starter; Generator	
03.1	Battery; Starter; Generator: AJ26 N/A	AJ26 N/A Vehicles
03.2	Battery; Starter; Generator: AJ26 SC	AJ26 SC Vehicles
04	Engine Management	
04.1	AJ26 N/A NAS Engine Management: Part 1	AJ26 N/A NAS Vehicles VIN 024687 →
04.2	AJ26 N/A ROW Engine Management: Part 1	AJ26 N/A ROW Vehicles VIN 024687 →
04.3	AJ26 N/A Engine Management: Part 2	AJ26 N/A Vehicles VIN 024687 →
04.4	AJ26 SC ROW Engine Management: Part 1	AJ26 SC ROW Vehicles
04.5	AJ26 SC ROW Engine Management: Part 2	AJ26 SC ROW Vehicles
05	Transmission	
05.1	AJ26 N/A Automatic Transmission	AJ26 N/A Vehicles
05.2	AJ26 SC Automatic Transmission	AJ26 SC Vehicles
05.3	Gearshift Interlock	All Vehicles
06	Anti-Lock Braking; Traction Control	
06.1	Anti-Lock Braking; Traction Control	All Vehicles
07	Climate Control	
07.1	Climate Control: Part 1	All Vehicles
07.2	Climate Control: Part 2	All Vehicles
08	Instrumentation; Audible Warnings	
08.1	Instrument Packs	All Vehicles
08.2	Audible Warnings	All Vehicles
09	Exterior Lighting	
09.1	Exterior Lighting: Front	All Vehicles
09.2	Exterior Lighting: Rear	All Vehicles
09.3	Headlamp Leveling	Headlamp Leveling Vehicles



FIGURES

Fig.	Description	Variant
10	Interior Lighting	
10.1	Interior Lighting	All Vehicles
10.2	Dimmer-Controlled Lighting	All Vehicles
11	Steering; Mirrors; Suspension	
11.1	Power Assisted Steering	All Vehicles
11.2	Steering Column Movement	All Vehicles
11.3	Mirror Movement	All Vehicles
11.4	Interior and Exterior Mirrors; Fold-Back Mirrors	All Vehicles
11.5	Suspension Adaptive Damping	Adaptive Damping Vehicles
12	Seat Systems	
12.1	Driver Seat: Memory	Memory Seat Vehicles
12.2	Driver Seat: Non Memory	Non Memory Seat Vehicles
12.3	Passenger Seat: 3-Way Movement	3-Way Movement Vehicles
12.4	Passenger Seat: 2-Way Movement	2-Way Movement Vehicles
13	Door Locking; Security	
13.1	Central Door Locking	All Vehicles
14	Wash / Wipe System	
14.1	Wash / Wipe System	All Vehicles
15	Window Lifts; Convertible Top	
15.1	Window Lifts	All Vehicles
15.2	Convertible Top	Convertible Vehicles
16	In-Car Entertainment; Telephone	
16.1	Standard In-Car Entertainment: Convertible	Convertible Vehicles
16.2	Standard In-Car Entertainment: Coupe	Coupe Vehicles
16.3	Premium In-Car Entertainment	Premium ICE Vehicles
16.4	Radio Telephone	All Vehicles
17	Supplementary Restraint System	
17.1	Airbag System	All Vehicles
18	Ancillaries	
18.1	Ancillaries: Horns; Cigar Lighters; Accessory Connectors; Garage Door Opener	All Vehicles
19	Vehicle Multiplex Systems	
19.1	CAN (Network); SCP Network; Serial Data Links	All Vehicles



ABS / TRACTION CONTROL CONTROL MODULE	Fig. 06.1	BRAKE SWITCH – LHD	Fig. 04.1
.....	Fig. 19.1	Fig. 04.2
ACCELEROMETERS	Fig. 11.5	Fig. 05.2
ACTIVE SECURITY SOUNDER	Fig. 13.2	Fig. 06.1
ADAPTIVE DAMPING CONTROL MODULE	Fig. 11.5	Fig. 09.2
.....	Fig. 19.1	Fig. 11.5
AIR CONDITIONING COMPRESSOR CLUTCH	Fig. 04.3	BRAKE SWITCH – RHD	Fig. 04.1
.....	Fig. 07.2	Fig. 04.2
AIR CONDITIONING CONTROL MODULE	Fig. 04.3	Fig. 05.2
.....	Fig. 07.1	Fig. 06.1
.....	Fig. 07.2	Fig. 09.2
.....	Fig. 19.1	Fig. 11.5
AIR CONDITIONING CONTROL PANEL	Fig. 07.1	CAMSHAFT POSITION SENSOR	Fig. 04.1
.....	Fig. 10.2	Fig. 04.2
AIR INTAKE – LH	Fig. 07.1	CANISTER CLOSE VALVE	Fig. 04.1
AIR INTAKE – RH	Fig. 07.1	CD AUTO-CHANGER	Fig. 16.1
AIRBAG / SRS CONTROL MODULE	Fig. 17.1	Fig. 16.2
.....	Fig. 19.1	Fig. 16.3
AIRBAG INTERROGATION CONNECTOR	Fig. 17.1	CENTER CONSOLE SWITCH PACK	Fig. 09.1
AIRBAGS	Fig. 17.1	Fig. 09.2
AMBIENT TEMPERATURE SENSOR	Fig. 07.1	Fig. 10.2
ANTENNA MOTOR	Fig. 16.3	CIGAR LIGHTERS	Fig. 10.2
ASPIRATOR ASSEMBLY	Fig. 07.1	Fig. 18.1
AUDIBLE WARNING SPEAKER (COLUMN SWITCHGEAR)	Fig. 08.2	COLUMN JOY STICK (COLUMN SWITCHGEAR)	Fig. 11.2
AUTO TILT SWITCH (COLUMN SWITCHGEAR)	Fig. 11.2	CONVERTIBLE TOP PUMP	Fig. 15.2
BATTERY	Fig. 01.1	CONVERTIBLE TOP SWITCH	Fig. 10.2
.....	Fig. 03.1	Fig. 15.2
BLOWER MOTORS	Fig. 07.2	COOLANT LEVEL SWITCH	Fig. 08.1
BODY PROCESSOR MODULE	Fig. 01.1	CRUISE CONTROL ON / OFF SWITCH	Fig. 10.2
.....	Fig. 03.1	CRUISE CONTROL SWITCH	Fig. 04.3
.....	Fig. 05.2	CRUISE CONTROL SWITCHES (STEERING WHEEL)	Fig. 04.3
.....	Fig. 08.2	D – 4 SWITCH	Fig. 05.1
.....	Fig. 09.1	DAMPER SOLENOIDS	Fig. 11.5
.....	Fig. 09.2	DATA LINK CONNECTOR	Fig. 19.1
.....	Fig. 10.1	DIMMER CONTROL (COLUMN SWITCHGEAR)	Fig. 10.2
.....	Fig. 11.2	DIMMER MODULE	Fig. 10.2
.....	Fig. 11.3	DIODE (BT29) – TRUNK SWITCH	Fig. 10.1
.....	Fig. 11.4	DOOR CONTROL MODULE – DRIVER	Fig. 10.1
.....	Fig. 12.1	Fig. 11.2
.....	Fig. 12.2	Fig. 11.3
.....	Fig. 12.3	Fig. 11.4
.....	Fig. 12.4	Fig. 12.1
.....	Fig. 13.1	Fig. 13.1
.....	Fig. 13.2	Fig. 13.2
.....	Fig. 13.3	Fig. 13.3
.....	Fig. 14.1	Fig. 15.1
.....	Fig. 15.1	Fig. 15.2
.....	Fig. 18.1	Fig. 19.1
.....	Fig. 19.1		
BRAKE CANCEL SWITCH – LHD	Fig. 04.3		
BRAKE CANCEL SWITCH – RHD	Fig. 04.3		
BRAKE FLUID RESERVOIR	Fig. 06.1		



DOOR CONTROL MODULE – PASSENGER	Fig. 10.1	FUEL PUMP	Fig. 04.3
.....	Fig. 11.3	FUEL TANK PRESURE SENSOR	Fig. 04.1
.....	Fig. 13.1	FULL RANGE SPEAKERS	Fig. 16.1
.....	Fig. 13.2	Fig. 16.2
.....	Fig. 13.3	FUSE BOX – DRIVER SIDE	Fig. 01.1
.....	Fig. 15.1	Fig. 01.2
.....	Fig. 15.2	Fig. 01.4
.....	Fig. 19.1	FUSE BOX – ENGINE COMPARTMENT	Fig. 01.1
DOOR LOCK ACTUATORS	Fig. 13.1	Fig. 01.3
DOOR LOCK SWITCH – PASSENGER	Fig. 13.1	Fig. 01.4
DOOR LOCK SWITCHES – DRIVER	Fig. 10.1	Fig. 07.2
.....	Fig. 13.1	Fig. 09.1
.....	Fig. 13.2	Fig. 13.2
.....	Fig. 13.3	Fig. 13.3
.....	Fig. 15.1	Fig. 14.1
DOOR MIRROR MOTORS	Fig. 11.3	Fig. 18.1
DOOR MIRRORS	Fig. 07.2	FUSE BOX – ENGINE MANAGEMENT	Fig. 01.1
.....	Fig. 11.4	Fig. 01.3
DOOR SWITCH – DRIVER	Fig. 10.1	Fig. 01.5
.....	Fig. 11.2	FUSE BOX – PASSENGER SIDE	Fig. 01.1
.....	Fig. 11.3	Fig. 01.2
.....	Fig. 13.1	Fig. 01.4
.....	Fig. 13.2	FUSE BOX – TRUNK	Fig. 01.1
.....	Fig. 13.3	Fig. 01.3
DOOR SWITCH – PASSENGER	Fig. 10.1	Fig. 01.4
.....	Fig. 13.1	Fig. 04.3
.....	Fig. 13.2	Fig. 07.2
.....	Fig. 13.3	Fig. 09.2
ECM AND TCM COOLING FAN	Fig. 04.1	Fig. 18.1
.....	Fig. 04.2	GARAGE DOOR OPENER (ROOF CONSOLE)	Fig. 18.1
ENGINE COMPARTMENT SECURITY SWITCH	Fig. 13.2	GEAR SELECTOR ILLUMINATION MODULE	Fig. 05.1
.....	Fig. 13.3	Fig. 05.2
ENGINE CONTROL MODULE	Fig. 03.1	Fig. 10.2
.....	Fig. 04.1	Fig. 19.1
.....	Fig. 04.2	GEARSHIFT INTERLOCK SOLENOID	Fig. 05.2
.....	Fig. 04.3	GENERATOR	Fig. 03.1
.....	Fig. 05.2	GLASS BREAKAGE SENSOR (ROOF CONSOLE)	Fig. 13.2
.....	Fig. 07.2	GLOVE BOX LAMP	Fig. 10.1
.....	Fig. 13.2	HANDSET	Fig. 16.4
.....	Fig. 13.3	HEADLAMP LEVELING ACTUATORS	Fig. 09.3
.....	Fig. 19.1	HEATED BACKLIGHT	Fig. 07.2
ENGINE COOLANT TEMPERATURE SENSOR	Fig. 04.1	HEATED OXYGEN SENSORS	Fig. 04.1
.....	Fig. 04.2	Fig. 04.2
ENGINE SPEED SENSOR	Fig. 04.1	HEATER PUMP	Fig. 07.2
.....	Fig. 04.2	HEATER VALVE	Fig. 07.2
EVAPORATIVE EMISSION CONTROL VALVE	Fig. 04.1	HIGH-MOUNTED STOP LAMP	Fig. 09.2
.....	Fig. 04.2	HIGH POWER PROTECTION MODULE	Fig. 01.1
EVAPORATOR / HEATER MATRIX ASSEMBLY	Fig. 07.1	Fig. 03.1
FASCIA ACCESSORY CONNECTOR	Fig. 18.1	HORN SWITCHES (STEERING WHEEL)	Fig. 18.1
FOOT WELL LAMPS	Fig. 10.1	HORNS	Fig. 13.2
FRONT FOG LAMPS	Fig. 09.1	Fig. 13.3
FRONT LAMP UNITS	Fig. 09.1	Fig. 18.1
FUEL FILL FLAP SOLENOID	Fig. 13.1		
FUEL INJECTORS	Fig. 04.3		
FUEL LEVEL SENSOR	Fig. 08.1		



IGNITION COILS	Fig. 04.3	MINOR INSTRUMENT PACK	Fig. 08.1
IGNITION MODULES	Fig. 04.3	Fig. 10.2
IGNITION SWITCH (KEY-IN SWITCH)	Fig. 10.1	MIRROR JOY STICK (DRIVER DOOR SWITCH PACK)	Fig. 11.3
.....	Fig. 11.2	Fig. 11.4
.....	Fig. 13.1	MODE SWITCH (TRANSMISSION)	Fig. 05.1
IGNITION SWITCH	Fig. 02.1	Fig. 10.2
.....	Fig. 03.1	NEUTRAL SWITCH	Fig. 03.1
IMPACT SENSORS	Fig. 17.1	NOT-IN-PARK MICROSWITCH	Fig. 05.2
INCLINATION SENSOR	Fig. 13.2	Fig. 11.2
INERTIA SWITCH	Fig. 02.1	Fig. 11.3
INTERIOR REAR VIEW MIRROR	Fig. 11.4	Fig. 13.1
KEY FOB ANTENNAS	Fig. 13.1	NUMBER PLATE LAMPS	Fig. 09.2
.....	Fig. 13.2	OIL PRESSURE SWITCH	Fig. 08.1
.....	Fig. 13.3	PARKING BRAKE SWITCH	Fig. 04.1
KEY TRANSPONDER MODULE	Fig. 03.1	Fig. 04.2
.....	Fig. 13.2	PASSIVE SECURITY SOUNDER	Fig. 13.2
.....	Fig. 13.3	Fig. 13.3
.....	Fig. 19.1	PEDAL POSITION AND MECHANICAL GUARD SENSORS	Fig. 04.1
KEYLOCK SOLENOID (COLUMN SWITCHGEAR)	Fig. 05.2	Fig. 04.2
KICKDOWN SWITCH – LHD	Fig. 05.1	POWER AMPLIFIER	Fig. 16.3
KICKDOWN SWITCH – RHD	Fig. 05.1	POWER ASSISTED STEERING CONTROL MODULE	Fig. 11.1
KNOCK SENSORS	Fig. 04.1	POWER WASH PUMP	Fig. 14.1
.....	Fig. 04.2	PUDDLE LAMPS	Fig. 10.1
LAMP CONTROL MODULE	Fig. 09.2	QUARTER LIGHT LIFTS	Fig. 15.2
LATCH CONTROL VALVE	Fig. 15.2	RADIATOR FAN CONTROL RELAY MODULE	Fig. 04.3
LEVELING SWITCH (CENTER CONSOLE SWITCH PACK)	Fig. 09.3	Fig. 07.2
LIGHTING STALK (COLUMN SWITCHGEAR)	Fig. 09.1	RADIATOR FANS	Fig. 04.3
.....	Fig. 09.2	Fig. 07.2
.....	Fig. 10.2	RADIO / CASSETTE HEAD UNIT	Fig. 16.1
.....	Fig. 11.4	Fig. 16.2
.....	Fig. 14.1	Fig. 16.3
MAIN CONTROL VALVE	Fig. 15.2	Fig. 16.4
MAJOR INSTRUMENT PACK	Fig. 05.2	RADIO ANTENNA	Fig. 16.1
.....	Fig. 08.1	Fig. 16.2
.....	Fig. 09.1	Fig. 16.3
.....	Fig. 09.2	RADIO CONTROL SWITCHES (STEERING WHEEL)	Fig. 16.1
.....	Fig. 10.2	Fig. 16.2
.....	Fig. 11.3	Fig. 16.3
.....	Fig. 11.4	RADIO ILLUMINATION	Fig. 10.2
.....	Fig. 12.1	READER / EXCITER COIL (COLUMN SWITCHGEAR)	Fig. 13.2
.....	Fig. 13.2	Fig. 13.3
.....	Fig. 13.3	REAR INTERIOR LAMP (COUPE ONLY)	Fig. 10.1
.....	Fig. 15.1	REAR QUARTER FULL RANGE SPEAKERS	Fig. 16.1
.....	Fig. 15.2	Fig. 16.2
.....	Fig. 16.1	REAR QUARTER MID-RANGE SPEAKERS	Fig. 16.3
.....	Fig. 16.2	REAR SUB-WOOFERS	Fig. 16.3
.....	Fig. 16.3	REFRIGERANT 4-WAY PRESSURE SWITCH	Fig. 04.3
.....	Fig. 19.1	Fig. 07.2
MASS AIR FLOW SENSOR	Fig. 04.1	REGULATOR	Fig. 03.1
.....	Fig. 04.2	ROOF CONSOLE	Fig. 10.1
MICROPHONE (TELEPHONE)	Fig. 16.4	Fig. 13.3
MID-BASS SPEAKERS	Fig. 16.3		



SEAT BELT SWITCH	Fig. 12.1	Fig. 12.1
.....	Fig. 12.2	SWITCH PACK – DRIVER SEAT	Fig. 12.1
SEAT CONTROL MODULE – DRIVER	Fig. 11.4	Fig. 12.2
.....	Fig. 12.1	SWITCH PACK – PASSENGER DOOR	Fig. 10.2
.....	Fig. 12.2	SWITCH PACK – PASSENGER SEAT	Fig. 12.3
.....	Fig. 19.1	Fig. 12.4
SEAT CONTROL MODULE – PASSENGER	Fig. 11.4	TAIL LAMP UNITS	Fig. 09.2
.....	Fig. 12.3	TELEPHONE ANTENNA	Fig. 16.4
.....	Fig. 12.4	TELEPHONE TRANSCEIVER	Fig. 16.4
.....	Fig. 19.1	THROTTLE MOTOR	Fig. 04.1
SEAT CUSHION (HEATER) – DRIVER	Fig. 12.1	Fig. 04.2
.....	Fig. 12.2	THROTTLE POSITION SENSOR	Fig. 04.1
SEAT CUSHION (HEATER) – PASSENGER	Fig. 12.3	Fig. 04.2
.....	Fig. 12.4	TOP CLOSED SWITCH	Fig. 15.2
SEAT HEATER SWITCH (CENTER CONSOLE SWITCH PACK)	Fig. 12.1	TOP DOWN SWITCH	Fig. 15.2
.....	Fig. 12.2	TOP LATCH CLOSED SWITCH	Fig. 15.2
.....	Fig. 12.3	TOP RAISED SWITCH	Fig. 15.2
.....	Fig. 12.4	TOP READY-TO-LATCH SWITCH	Fig. 15.2
SEAT LUMBAR PUMP – DRIVER	Fig. 12.1	TRANSIT ISOLATION DEVICE	Fig. 01.1
.....	Fig. 12.2	TRANSMISSION CONTROL MODULE	Fig. 05.1
SEAT LUMBAR PUMP – PASSENGER	Fig. 12.3	Fig. 19.1
SEAT MOTORS – DRIVER	Fig. 12.1	TRANSMISSION ELECTRICS	Fig. 05.1
.....	Fig. 12.2	TRANSMISSION ROTARY SWITCH	Fig. 05.1
SEAT MOTORS – PASSENGER	Fig. 12.3	TRIP COMPUTER SWITCH PACK	Fig. 08.1
.....	Fig. 12.4	Fig. 10.2
SECURITY ACTIVE INDICATOR (GEAR SELECTOR MODULE)	Fig. 13.2	TRIP CYCLE SWITCH (COLUMN SWITCHGEAR)	Fig. 08.1
.....	Fig. 13.3	TRUNK ACCESSORY CONNECTOR	Fig. 18.1
SECURITY AND LOCKING CONTROL MODULE	Fig. 09.2	TRUNK AND FUEL FILL RELEASE SWITCH	Fig. 10.2
.....	Fig. 11.4	Fig. 13.1
.....	Fig. 13.1	TRUNK LAMPS	Fig. 10.1
.....	Fig. 13.2	TRUNK RELEASE SOLENOID	Fig. 13.1
.....	Fig. 13.3	TRUNK SWITCH	Fig. 10.1
.....	Fig. 15.1	Fig. 13.1
.....	Fig. 15.2	Fig. 13.2
.....	Fig. 19.1	Fig. 13.3
SIDE DI REPEATERS (ROW)	Fig. 09.1	TWEETERS	Fig. 16.3
.....	Fig. 09.1	VACUUM SWITCHING VALVES	Fig. 04.1
SIDE MARKERS (NAS ONLY)	Fig. 09.1	Fig. 04.2
.....	Fig. 09.2	VALET SWITCH	Fig. 10.2
SOLAR SENSOR	Fig. 07.1	Fig. 13.1
SQUAB (HEATERS) – DRIVER	Fig. 12.1	Fig. 13.2
.....	Fig. 12.2	Fig. 13.3
SQUAWKERS (FASCIA)	Fig. 16.3	VANITY LAMPS	Fig. 10.1
STABILITY / TRACTION CONTROL SWITCH (CENTER CONSOLE SWITCH PACK)	Fig. 06.1	VARIABLE STEERING CONVERTER – LHD	Fig. 11.1
STARTER MOTOR	Fig. 03.1	VARIABLE STEERING CONVERTER – RHD	Fig. 11.1
STEERING COLUMN MOTORS	Fig. 11.2		
SUPPRESSION MODULE	Fig. 03.1		
SWITCH PACK – DRIVER DOOR	Fig. 10.2		
SWITCH PACK – DRIVER DOOR MEMORY	Fig. 10.2		
.....	Fig. 11.2		
.....	Fig. 11.3		



VARIABLE VALVE TIMING SOLENOID VALVES Fig. 04.1
..... Fig. 04.2

VENT ASSEMBLY Fig. 07.1

WASH / WIPE STALK (COLUMN SWITCHGEAR) Fig. 14.1

WHEEL SPEED SENSORS Fig. 06.1

WINDOW LIFT SWITCHES – DRIVER DOOR
(DRIVER DOOR SWITCH PACK) Fig. 15.1

WINDOW LIFT SWITCHES – PASSENGER DOOR
(PASSENGER DOOR SWITCH PACK) Fig. 15.1

WINDOW LIFTS Fig. 15.1

WINDSHIELD HEATERS Fig. 07.2

WINDSHIELD WASH PUMP AND FLUID LEVEL SENSOR Fig. 14.1

WIPER MOTOR Fig. 14.1



Figure and Data Page Layout

Figure Pages

Each Figure represents a specific electrical system of the vehicle. The Figures are arranged numerically by system (**01 – Power Distribution**, **02 – Ground Distribution**, etc.) with variations in the system identified by a numeral following a decimal point (**01.1**, **01.2**, etc.). Refer to the Table of Contents for a complete list of the Figures.

The Figures **01 – Power Distribution** detail the distribution of power to each of the systems. Numbered reference symbols refer the user to a specific Figure and from a specific Figure back to the Power Distribution Figures. This method eliminates the need to include detailed Power Distribution information on each of the Figures. Similarly, the Figure **02 – Ground Distribution** details the ignition switched ground distribution. The reference symbols are defined on page 12.

Each Figure appears on a right-hand page with a corresponding Data page to the left. The Figure and Data pages are folding pages. The user must fold out both pages in order to access all the information provided.

Data Pages

The Data page includes information to assist the user in identifying and locating components, connectors and grounds. This information is supplemented by the illustrations in this front section of the book.

When network data is required for the understanding of a particular circuit, the user is directed to the Appendix.

Where circuits include a Control Module, Pin Out information is provided with values for "active" and "inactive" states. The values listed are approximately those that can be expected at the control module connector pins with all circuit connections made and all components connected and fitted. "Active" means a load is applied or a switch is ON; "inactive" means a load is not applied or a switch is OFF. This information is provided to assist the user in understanding circuit operation and should be used FOR REFERENCE ONLY.



CONTROL MODULE PIN OUT INFORMATION

FIGURE NUMBER

COMPONENT, RELAY, CONNECTOR AND GROUND INFORMATION

CONTROL MODULE PIN OUT INFORMATION

BODY PROCESSOR MODULE

Pin	Description	Active	Inactive
FC14-7	NEUTRAL SWITCH STATUS	GROUND (N)	B- (P, R, S, 1, 2)
FC14-8	SECURITY KNOWLEDGE	ENCLOSED COMMUNICATIONS	B-
FC14-11	STARTER ENGINE REDUCED	GROUND (DRIVING)	B-
FC14-12	STARTER RELAY ACTIVE	GROUND (DRIVING)	B-
FC14-16	BATTERY SUPPLY VOLTAGE	B-	B-
FC14-17	ENCLOSED COMMUNICATIONS	B-	B-

ENGINE CONTROL MODULE

Pin	Description	Active	Inactive
D14B-6	OK TO START - ENCLOSED COMMUNICATIONS	ENCLOSED COMMUNICATIONS	GROUND (R, S, 1, 2)
D14B-15	PARK NEUTRAL CONFIRMATION	B- (P, N)	GROUND (R, S, 1, 2)
D14B-17	SECURITY KNOWLEDGE	ENCLOSED COMMUNICATIONS	B-
D14B-18	ENGINE DRAIN	ENCLOSED COMMUNICATIONS	B-

KEY TRANSPONDER MODULE

Pin	Description	Active	Inactive
FC22-9	GLASS BREAKAGE OK TO START (ENCLOSED COMMUNICATION)	B-	B-
FC22-14	OK TO START (ENCLOSED COMMUNICATION)	B-	B-
FC22-17	SECURITY KNOWLEDGE (ENCLOSED COMMUNICATION)	B-	B-

Fig. 03.1

Component	Connector / Type / Color	Location / Access
BATTERY	EN14 (EN14)	TRUNK, RIGHT HAND SIDE
BODY PROCESSOR MODULE	FC14 (16-WAY AMP REEC / GREY)	PASSENGER SIDE FASCIA / AIRBAG BRACKET
ENGINE CONTROL MODULE	D14B (16-WAY MULTICOLORED / GREY)	ENGINE COMPARTMENT / CONTROL MODULE ENCLOSURE
GENERATOR	AN1 (EN14)	ENGINE COMPARTMENT / RIGHT FRONT
HIGH POWER PROTECTION MODULE	ST11 (EN14)	TRUNK / ADJACENT TO BATTERY
IGNITION SWITCH KEY TRANSPONDER MODULE	FC14 (16-WAY MULTICOLORED / WHITE)	STEERING COLUMN
NEUTRAL SWITCH	FC22 (20-WAY MULTICOLORED / GREEN)	ADJACENT TO DRIVER SIDE FUSE BOX
REGULATOR (GENERATOR)	FC22 (20-WAY MULTICOLORED / GREY)	GEAR SELECTOR ASSEMBLY
STARTER MOTOR	ST1 (EN14)	ENGINE COMPARTMENT / GENERATOR
SUPPRESSION MODULE	ST1 (EN14)	ENGINE BLOCK
	AN1 (2-WAY ECONOLUX / B/L RED)	REARWARD OF RIGHT FRONT HEADLAMP

Relay	Color / Stripe	Connector / Color	Location / Access
STARTER RELAY	BROWN	EN14 (BROWN)	RH ENCLOSURE RELAYS

HARNESSES-TO-HARNESSES CONNECTORS

Connector	Type / Color	Location / Access
EN14	EN14 (EN14)	ENGINE COMPARTMENT / FASCIA BULKHEAD, RIGHT HAND SIDE
EN17	EN17 (EN17)	ENGINE COMPARTMENT / ADJACENT TO RIGHT HAND ENCLOSURE
EN18	EN18 (EN18)	ENGINE COMPARTMENT / ADJACENT TO RIGHT HAND ENCLOSURE
EN19	EN19 (EN19)	ENGINE COMPARTMENT / ADJACENT TO RIGHT HAND ENCLOSURE
EN20	EN20 (EN20)	ENGINE COMPARTMENT / ADJACENT TO RIGHT HAND ENCLOSURE
EN21	EN21 (EN21)	ENGINE COMPARTMENT / ADJACENT TO RIGHT HAND ENCLOSURE
EN22	EN22 (EN22)	ENGINE COMPARTMENT / ADJACENT TO RIGHT HAND ENCLOSURE
EN23	EN23 (EN23)	ENGINE COMPARTMENT / ADJACENT TO RIGHT HAND ENCLOSURE
EN24	EN24 (EN24)	ENGINE COMPARTMENT / ADJACENT TO RIGHT HAND ENCLOSURE
EN25	EN25 (EN25)	ENGINE COMPARTMENT / ADJACENT TO RIGHT HAND ENCLOSURE
EN26	EN26 (EN26)	ENGINE COMPARTMENT / ADJACENT TO RIGHT HAND ENCLOSURE
EN27	EN27 (EN27)	ENGINE COMPARTMENT / ADJACENT TO RIGHT HAND ENCLOSURE
EN28	EN28 (EN28)	ENGINE COMPARTMENT / ADJACENT TO RIGHT HAND ENCLOSURE
EN29	EN29 (EN29)	ENGINE COMPARTMENT / ADJACENT TO RIGHT HAND ENCLOSURE
EN30	EN30 (EN30)	ENGINE COMPARTMENT / ADJACENT TO RIGHT HAND ENCLOSURE
EN31	EN31 (EN31)	ENGINE COMPARTMENT / ADJACENT TO RIGHT HAND ENCLOSURE
EN32	EN32 (EN32)	ENGINE COMPARTMENT / ADJACENT TO RIGHT HAND ENCLOSURE
EN33	EN33 (EN33)	ENGINE COMPARTMENT / ADJACENT TO RIGHT HAND ENCLOSURE
EN34	EN34 (EN34)	ENGINE COMPARTMENT / ADJACENT TO RIGHT HAND ENCLOSURE
EN35	EN35 (EN35)	ENGINE COMPARTMENT / ADJACENT TO RIGHT HAND ENCLOSURE
EN36	EN36 (EN36)	ENGINE COMPARTMENT / ADJACENT TO RIGHT HAND ENCLOSURE
EN37	EN37 (EN37)	ENGINE COMPARTMENT / ADJACENT TO RIGHT HAND ENCLOSURE
EN38	EN38 (EN38)	ENGINE COMPARTMENT / ADJACENT TO RIGHT HAND ENCLOSURE
EN39	EN39 (EN39)	ENGINE COMPARTMENT / ADJACENT TO RIGHT HAND ENCLOSURE
EN40	EN40 (EN40)	ENGINE COMPARTMENT / ADJACENT TO RIGHT HAND ENCLOSURE
EN41	EN41 (EN41)	ENGINE COMPARTMENT / ADJACENT TO RIGHT HAND ENCLOSURE
EN42	EN42 (EN42)	ENGINE COMPARTMENT / ADJACENT TO RIGHT HAND ENCLOSURE
EN43	EN43 (EN43)	ENGINE COMPARTMENT / ADJACENT TO RIGHT HAND ENCLOSURE
EN44	EN44 (EN44)	ENGINE COMPARTMENT / ADJACENT TO RIGHT HAND ENCLOSURE
EN45	EN45 (EN45)	ENGINE COMPARTMENT / ADJACENT TO RIGHT HAND ENCLOSURE
EN46	EN46 (EN46)	ENGINE COMPARTMENT / ADJACENT TO RIGHT HAND ENCLOSURE
EN47	EN47 (EN47)	ENGINE COMPARTMENT / ADJACENT TO RIGHT HAND ENCLOSURE
EN48	EN48 (EN48)	ENGINE COMPARTMENT / ADJACENT TO RIGHT HAND ENCLOSURE
EN49	EN49 (EN49)	ENGINE COMPARTMENT / ADJACENT TO RIGHT HAND ENCLOSURE
EN50	EN50 (EN50)	ENGINE COMPARTMENT / ADJACENT TO RIGHT HAND ENCLOSURE
EN51	EN51 (EN51)	ENGINE COMPARTMENT / ADJACENT TO RIGHT HAND ENCLOSURE
EN52	EN52 (EN52)	ENGINE COMPARTMENT / ADJACENT TO RIGHT HAND ENCLOSURE
EN53	EN53 (EN53)	ENGINE COMPARTMENT / ADJACENT TO RIGHT HAND ENCLOSURE
EN54	EN54 (EN54)	ENGINE COMPARTMENT / ADJACENT TO RIGHT HAND ENCLOSURE
EN55	EN55 (EN55)	ENGINE COMPARTMENT / ADJACENT TO RIGHT HAND ENCLOSURE
EN56	EN56 (EN56)	ENGINE COMPARTMENT / ADJACENT TO RIGHT HAND ENCLOSURE
EN57	EN57 (EN57)	ENGINE COMPARTMENT / ADJACENT TO RIGHT HAND ENCLOSURE
EN58	EN58 (EN58)	ENGINE COMPARTMENT / ADJACENT TO RIGHT HAND ENCLOSURE
EN59	EN59 (EN59)	ENGINE COMPARTMENT / ADJACENT TO RIGHT HAND ENCLOSURE
EN60	EN60 (EN60)	ENGINE COMPARTMENT / ADJACENT TO RIGHT HAND ENCLOSURE
EN61	EN61 (EN61)	ENGINE COMPARTMENT / ADJACENT TO RIGHT HAND ENCLOSURE
EN62	EN62 (EN62)	ENGINE COMPARTMENT / ADJACENT TO RIGHT HAND ENCLOSURE
EN63	EN63 (EN63)	ENGINE COMPARTMENT / ADJACENT TO RIGHT HAND ENCLOSURE
EN64	EN64 (EN64)	ENGINE COMPARTMENT / ADJACENT TO RIGHT HAND ENCLOSURE
EN65	EN65 (EN65)	ENGINE COMPARTMENT / ADJACENT TO RIGHT HAND ENCLOSURE
EN66	EN66 (EN66)	ENGINE COMPARTMENT / ADJACENT TO RIGHT HAND ENCLOSURE
EN67	EN67 (EN67)	ENGINE COMPARTMENT / ADJACENT TO RIGHT HAND ENCLOSURE
EN68	EN68 (EN68)	ENGINE COMPARTMENT / ADJACENT TO RIGHT HAND ENCLOSURE
EN69	EN69 (EN69)	ENGINE COMPARTMENT / ADJACENT TO RIGHT HAND ENCLOSURE
EN70	EN70 (EN70)	ENGINE COMPARTMENT / ADJACENT TO RIGHT HAND ENCLOSURE
EN71	EN71 (EN71)	ENGINE COMPARTMENT / ADJACENT TO RIGHT HAND ENCLOSURE
EN72	EN72 (EN72)	ENGINE COMPARTMENT / ADJACENT TO RIGHT HAND ENCLOSURE
EN73	EN73 (EN73)	ENGINE COMPARTMENT / ADJACENT TO RIGHT HAND ENCLOSURE
EN74	EN74 (EN74)	ENGINE COMPARTMENT / ADJACENT TO RIGHT HAND ENCLOSURE
EN75	EN75 (EN75)	ENGINE COMPARTMENT / ADJACENT TO RIGHT HAND ENCLOSURE
EN76	EN76 (EN76)	ENGINE COMPARTMENT / ADJACENT TO RIGHT HAND ENCLOSURE
EN77	EN77 (EN77)	ENGINE COMPARTMENT / ADJACENT TO RIGHT HAND ENCLOSURE
EN78	EN78 (EN78)	ENGINE COMPARTMENT / ADJACENT TO RIGHT HAND ENCLOSURE
EN79	EN79 (EN79)	ENGINE COMPARTMENT / ADJACENT TO RIGHT HAND ENCLOSURE
EN80	EN80 (EN80)	ENGINE COMPARTMENT / ADJACENT TO RIGHT HAND ENCLOSURE
EN81	EN81 (EN81)	ENGINE COMPARTMENT / ADJACENT TO RIGHT HAND ENCLOSURE
EN82	EN82 (EN82)	ENGINE COMPARTMENT / ADJACENT TO RIGHT HAND ENCLOSURE
EN83	EN83 (EN83)	ENGINE COMPARTMENT / ADJACENT TO RIGHT HAND ENCLOSURE
EN84	EN84 (EN84)	ENGINE COMPARTMENT / ADJACENT TO RIGHT HAND ENCLOSURE
EN85	EN85 (EN85)	ENGINE COMPARTMENT / ADJACENT TO RIGHT HAND ENCLOSURE
EN86	EN86 (EN86)	ENGINE COMPARTMENT / ADJACENT TO RIGHT HAND ENCLOSURE
EN87	EN87 (EN87)	ENGINE COMPARTMENT / ADJACENT TO RIGHT HAND ENCLOSURE
EN88	EN88 (EN88)	ENGINE COMPARTMENT / ADJACENT TO RIGHT HAND ENCLOSURE
EN89	EN89 (EN89)	ENGINE COMPARTMENT / ADJACENT TO RIGHT HAND ENCLOSURE
EN90	EN90 (EN90)	ENGINE COMPARTMENT / ADJACENT TO RIGHT HAND ENCLOSURE
EN91	EN91 (EN91)	ENGINE COMPARTMENT / ADJACENT TO RIGHT HAND ENCLOSURE
EN92	EN92 (EN92)	ENGINE COMPARTMENT / ADJACENT TO RIGHT HAND ENCLOSURE
EN93	EN93 (EN93)	ENGINE COMPARTMENT / ADJACENT TO RIGHT HAND ENCLOSURE
EN94	EN94 (EN94)	ENGINE COMPARTMENT / ADJACENT TO RIGHT HAND ENCLOSURE
EN95	EN95 (EN95)	ENGINE COMPARTMENT / ADJACENT TO RIGHT HAND ENCLOSURE
EN96	EN96 (EN96)	ENGINE COMPARTMENT / ADJACENT TO RIGHT HAND ENCLOSURE
EN97	EN97 (EN97)	ENGINE COMPARTMENT / ADJACENT TO RIGHT HAND ENCLOSURE
EN98	EN98 (EN98)	ENGINE COMPARTMENT / ADJACENT TO RIGHT HAND ENCLOSURE
EN99	EN99 (EN99)	ENGINE COMPARTMENT / ADJACENT TO RIGHT HAND ENCLOSURE
EN100	EN100 (EN100)	ENGINE COMPARTMENT / ADJACENT TO RIGHT HAND ENCLOSURE

GROUNDINGS

Ground	Location / Type
EN14	BATTERY (GROUND STRIP)
EN18	EN18 (EN18) - RIGHT HAND LEG / TRANSMISSION TUNNEL, LEFT HAND SIDE

CONTROL MODULE PIN OUT INFORMATION (FOLD OUT PAGE)

The following symbols are used to represent values for Control Module Pin Out data:

- I Input
- O Output
- Sg Signal Ground
- D Serial and encoded communications
- C CAN (Network)
- SCP Network
- B- Battery voltage
- V Voltage (DC)
- Hz Frequency
- KHz Frequency x 1000
- MS Milliseconds
- MV Millivolts

CAUTION: The information on this data page is furnished to aid the user in understanding circuit operation. THIS INFORMATION SHOULD BE USED FOR REFERENCE ONLY.

NOTE: The values listed are approximately those that can be expected at the control module connector pins with all circuit connections made and all components connected and fitted. "Active" means a load is applied or a switch is ON. "Inactive" means a load is not applied or a switch is OFF.

REFER TO THE FRONT OF THE BOOK FOR ILLUSTRATIONS DETAILING THE LOCATION AND IDENTIFICATION OF COMPONENTS, RELAYS, CONNECTORS, HARNESSES, GROUNDS, VEHICLE CONTROL MODULES AND CONTROL MODULE PINS.

DATE OF ISSUE: FEBRUARY 1998

DATE OF ISSUE

DATA PAGE

FIGURE MODEL RANGE AND YEAR TITLE FIGURE NUMBER

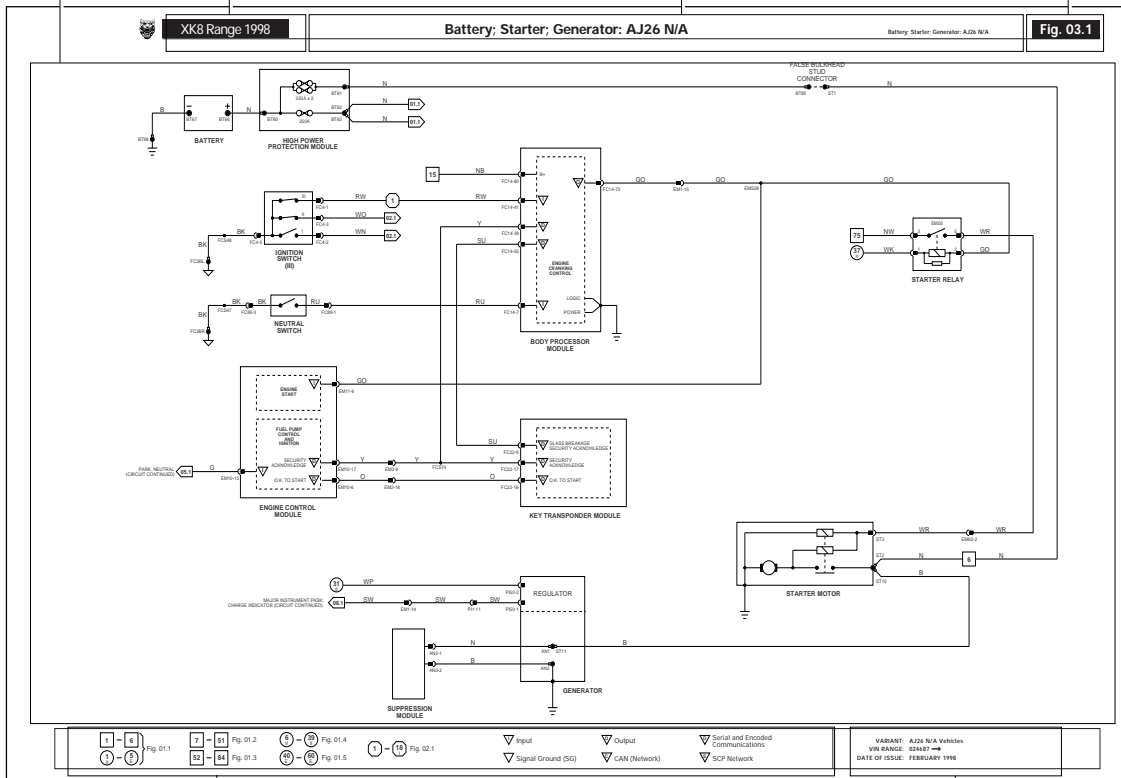

KEY TO REFERENCE SYMBOLS

FIGURE PAGE

VARIANT, VIN RANGE AND DATE OF ISSUE



NOTE: In the examples shown on this page, an 'X' is used where a number would appear on an actual Figure.

Reference Symbols

Reference symbols are used for three purposes:

- to allow the user to complete the individual system circuit to power supply or ground
- to refer the user to a related circuit
- to identify control module inputs, outputs and signal grounds

 **Battery Power Supply**

This symbol represents a direct battery power supply and refers the user to Figure 01.1, 01.2 or 01.3.

 **Ignition Switched Power Supply**

This symbol represents ignition switched power supply and refers the user to Figure 01.1, 01.4 or 01.5.

The suffix I indicates auxiliary power. Power is supplied in ignition switch key positions I (AUXILIARY) and II (IGNITION).

The suffix II indicates ignition power. Power is supplied in ignition switch key positions II (IGNITION) and III (ENGINE CRANK).

The suffix E indicates engine management switched power. Power is supplied in ignition switch key positions II (IGNITION) and III (ENGINE CRANK) under ECM control.

 **Ignition Switched Ground**

This symbol represents an ignition switched ground and refers the user to Figure 02.1.

This symbol without a suffix indicates CRANK. Ground is completed in ignition switch key position III (ENGINE CRANK).

The suffix I indicates auxiliary ground. Ground is completed in ignition switch key positions I (AUXILIARY) and II (IGNITION).

The suffix II indicates ignition ground. Ground is completed in ignition switch key positions II (IGNITION) and III (ENGINE CRANK).

 **Figure Number Reference Flag**

This symbol refers the reader to a figure number only. It does not refer to a flag with the same number on a different figure.

As used in Figures 01.1 through 02.1, the reference flag refers the user to a continuation of the circuit. In this instance, the user matches the number to a Power Supply or Ground symbol to trace the circuit.

In most other cases, it is not necessary to refer to another figure for completion of a circuit, as the reference flags are used to indicate parallel circuits and circuits that share components. Most of the circuits where this situation occurs are overlapped to avoid the necessity for cross-referencing to another figure. Exceptions to this rule are instances where signals are transmitted to or received from other system circuits. When circuits are not overlapped, they are noted by (CIRCUIT CONTINUED).

BPM Because the Body Processor Module appears numerous times, the abbreviation BPM is used in the reference flags on Figures 01.2 and 02.1 in order to conserve space.

Control Module Input, Output, Data Link, Signal Ground and Network(s)

-  Input
-  Output
-  Serial and Encoded Communications
-  Signal Ground (SG)
-  CAN (Network)
-  SCP Network

These six symbols are employed to assist the user in visualizing the 'logic' of circuits containing control modules. The symbols identify control module input, output, data link, signal ground and network pins. These symbols are also employed on the corresponding data page.



Wiring Symbols

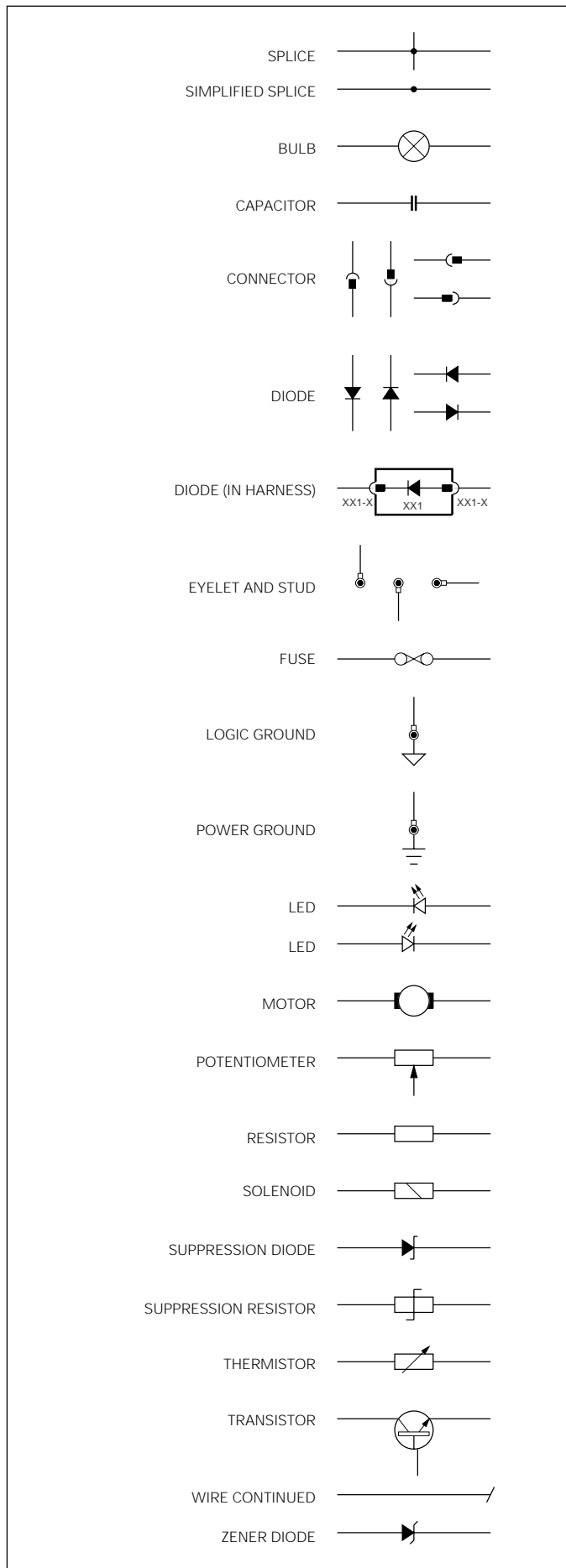

Wiring Color Codes

N	Brown	O	Orange
B	Black	S	Slate
W	White	L	Light
K	Pink	U	Blue
G	Green	P	Purple
R	Red	BRD	Braid
Y	Yellow		

When a wire has two or more color code letters, the first letter indicates the main color and the subsequent letter(s) indicate the tracer color(s).

Wiring Harness Codes

Code	Description
AC	Air Conditioning (Climate Control)
AN	Generator Suppression Module
AS	Generator to Starter
BB	Trunk Bridging Link
BC	Main Power Distribution
BL	Trunk Lid
BT	Trunk
DD	Door, Driver
DP	Door, Passenger
EL	Engine Management Cruise Control Link
EM	Engine Management
EN	Engine Management Side Marker Link
FC	Fascia
FL	LH Front Wheel
FR	RH Front Wheel
IC	In-Car Entertainment
IS	Inclination Sensor Link
LF	Left Forward
LL	Power Steering Link
PI	Engine
QL	Convertible LH Quarter Light Link
QR	Convertible RH Quarter Light Link
RF	Roof
RH	Rearward
RL	LH Rear Wheel
RR	RH Rear Wheel
RT	Radio Telephone
SA	Starter to Generator Link
SC	Column Switchgear
SD	Seat, Driver
SP	Seat, Passenger
SW	Steering Wheel
TL	Telephone

Code Numbering

When numbering connectors, grounds and splices, Jaguar Engineering uses a three-position format: AC001, AC002, etc. Because space is limited in this Electrical Guide, the codes have been shortened. Thus AC001-001 becomes AC1-1, AC002-001 becomes AC2-1, etc.



Harness Component Numbers

Connectors

HARNESS CODE + CONNECTOR NUMBER + PIN NUMBER

EXAMPLE: FC7-24 (pin number is separated by a dash)

Where the pin number differs from LHD to RHD, the connector number will be further identified by (LHD) or (RHD).

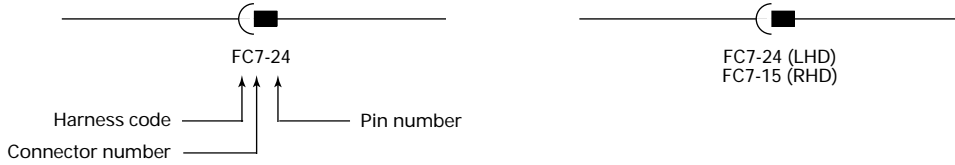

Splices

HARNESS CODE + S (SPLICE) + SPLICE NUMBER

EXAMPLE: RHS3 (no dash is used)

NOTE: In order to avoid unnecessary circuit complication, multiple splices (more than two wires) within components, in wires leading from input components to multiple circuits and in harness 'ground' sides, are simplified so as not to show wires from other circuits.

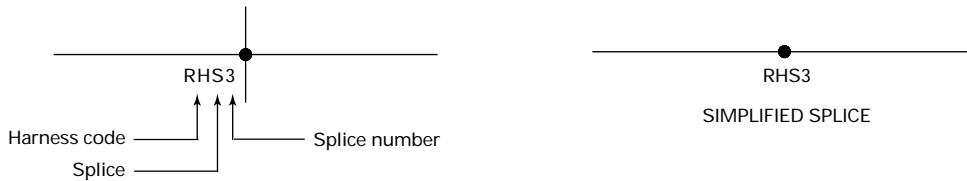

Diodes

Harness diodes occur at connectors and are depicted as components and identified by a connector number.

EXAMPLE:



Relay Connectors

Relay connector numbers are shown within the relay. The connector number is shown in the upper portion of the relay; the pin (terminal) number is shown adjacent to the pin. Certain relays are paired and share a modular connector. In this instance, the connector number remains the same for both relays while the pin numbers of the second relay are identified by numbers 6 – 10.

EXAMPLE:

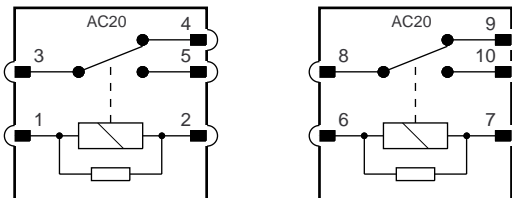



Grounds

HARNESS CODE + GROUND STUD NUMBER + EYELET STUD POSITION (A,B,C) + EYELET DESIGNATION (S,L,R)

Eyelet stud position

There may be up to three eyelets on one stud. A, B and C are used to indicate the position of the eyelet on the stud: A – first (bottom), B – second (middle), C – third (top).

Eyelet designation

Two eyelet variations are used: a single eyelet and an eyelet pair. The single eyelet has a single 'leg', which is identified by an S; the eyelet pair has two 'legs', identified as L (left) or R (right).

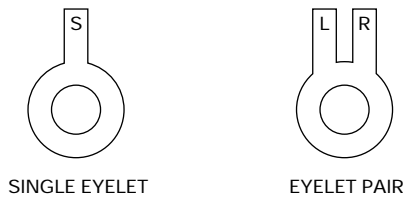

EXAMPLES:

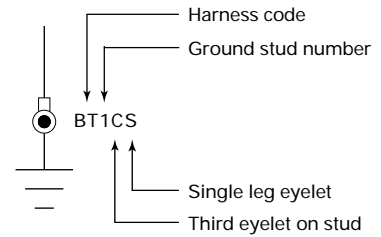
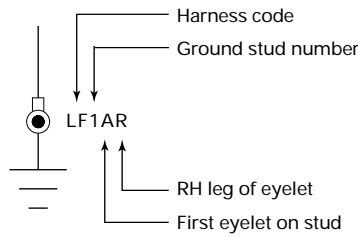
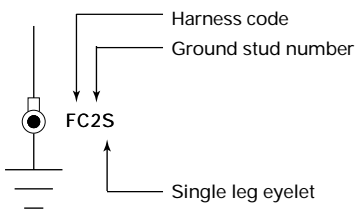

Where the ground designation differs from LHD to RHD, the RHD ground is shown in parentheses. If the ground designation is the same for LHD and RHD, only one ground designation is used.

EXAMPLES:

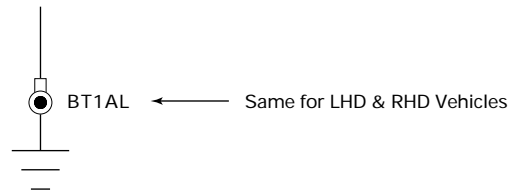
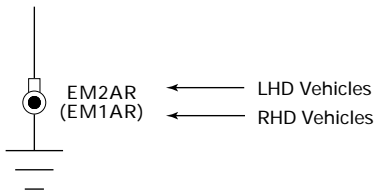



The following connectors are the common harness-to-harness connectors used throughout the vehicle.

Multilock 040

Low current (used as harness and 'direct' connection connector).

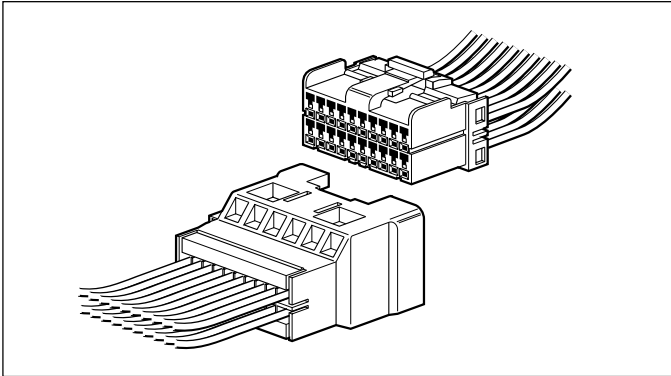

Multilock 070

High current (used as harness and 'direct' connection connector).

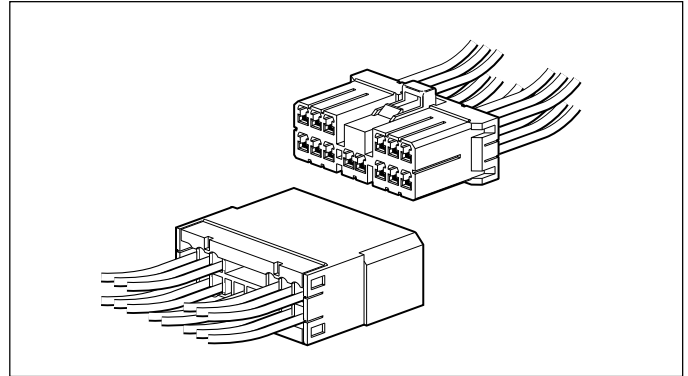

Econoseal III LC

Low current sealed connector.

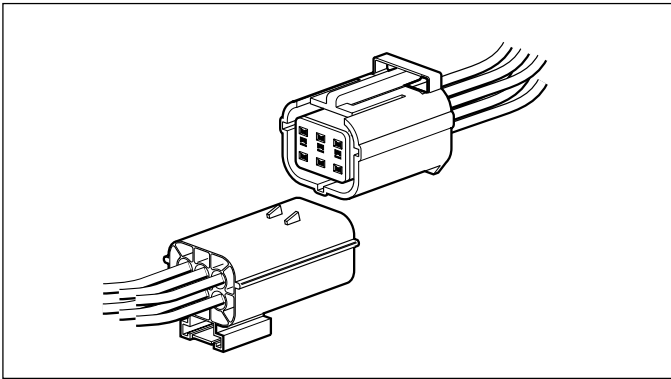

Econoseal III HC

High current sealed connector.

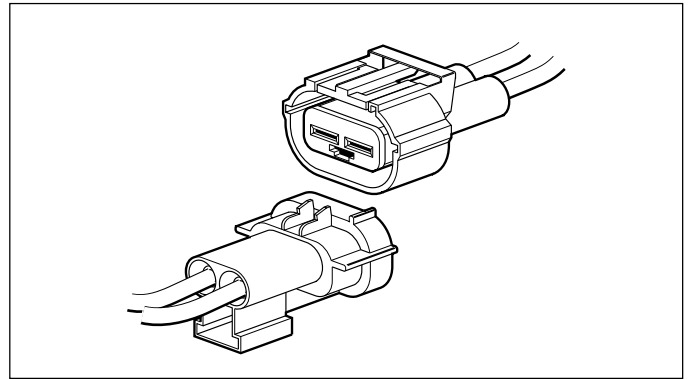

Ford Card

Used for SRS only.

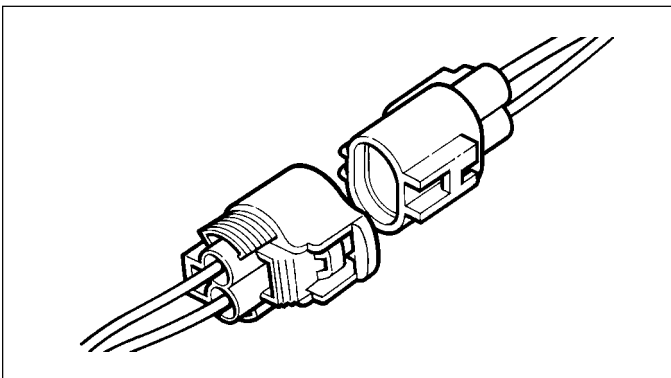



GROUND POINTS

MAIN POWER DISTRIBUTION

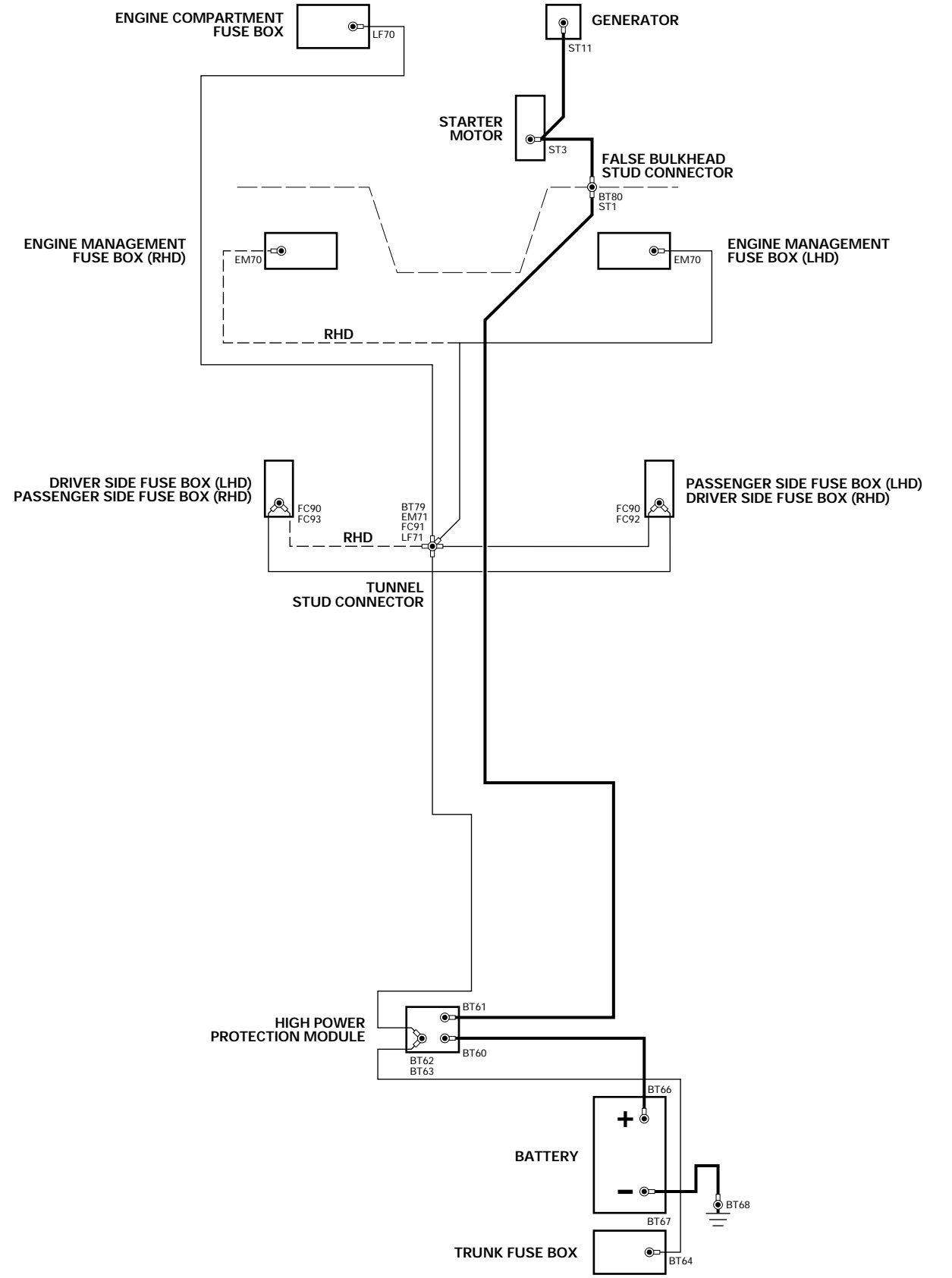
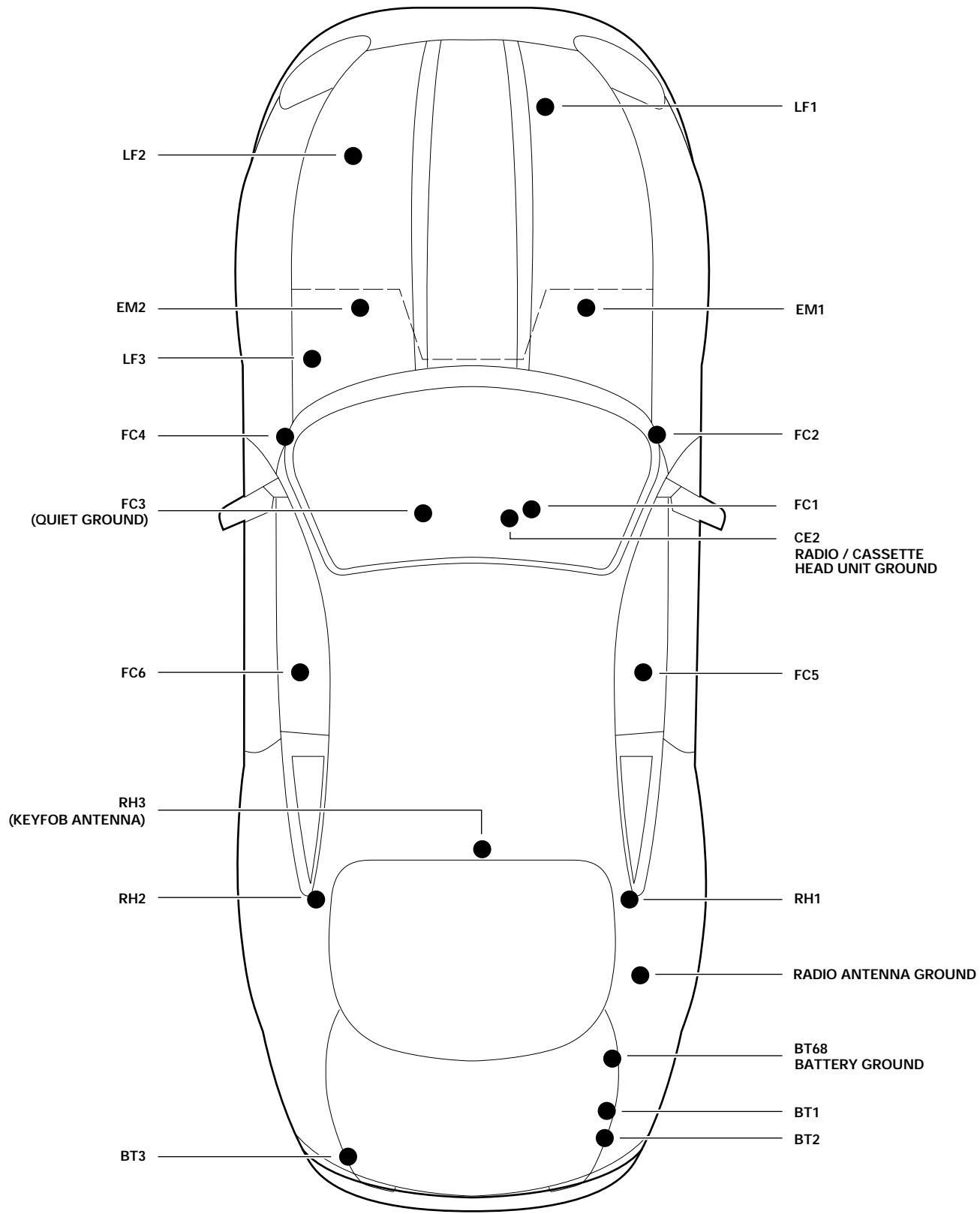



LHD

RHD

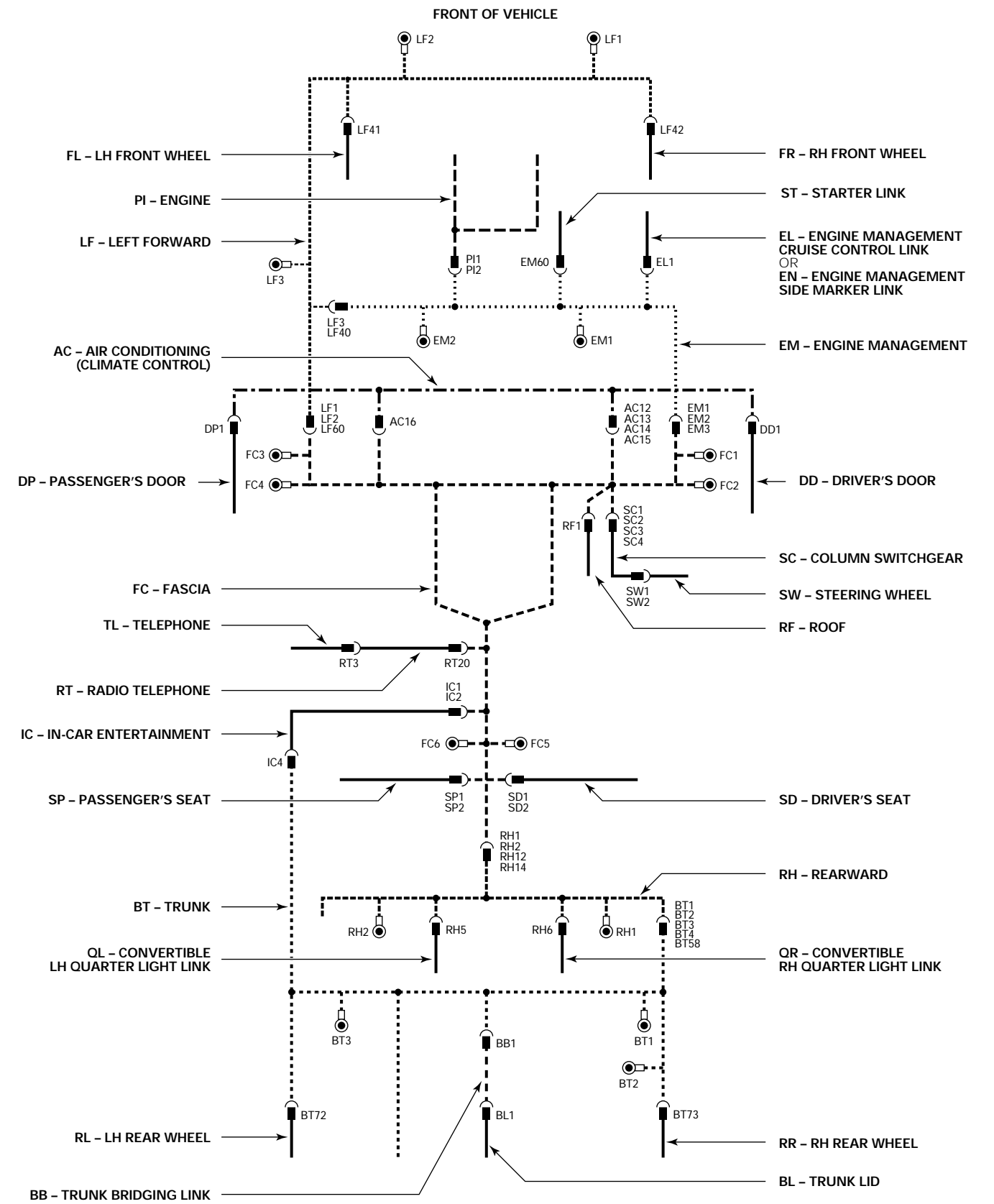
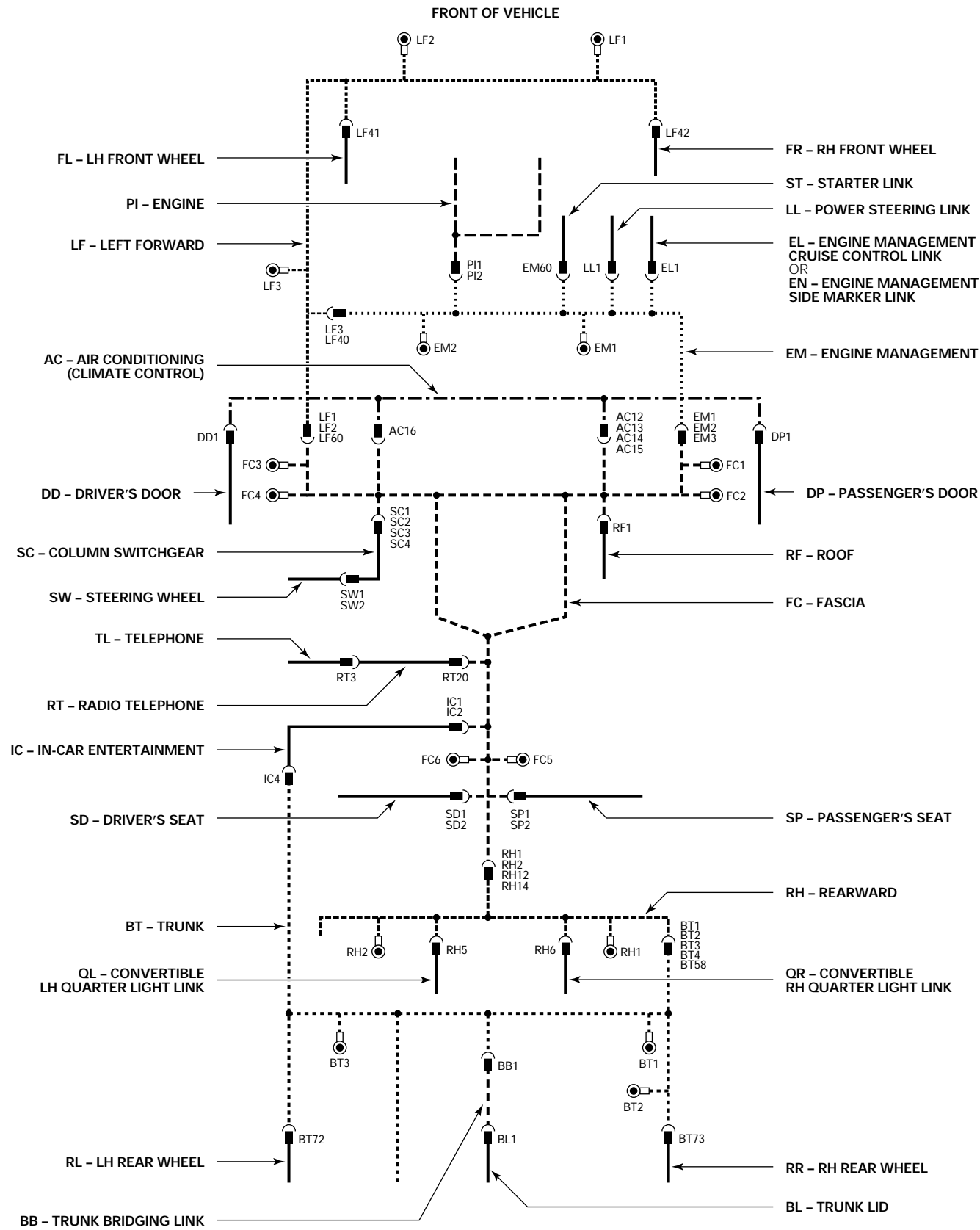



LHD

RHD

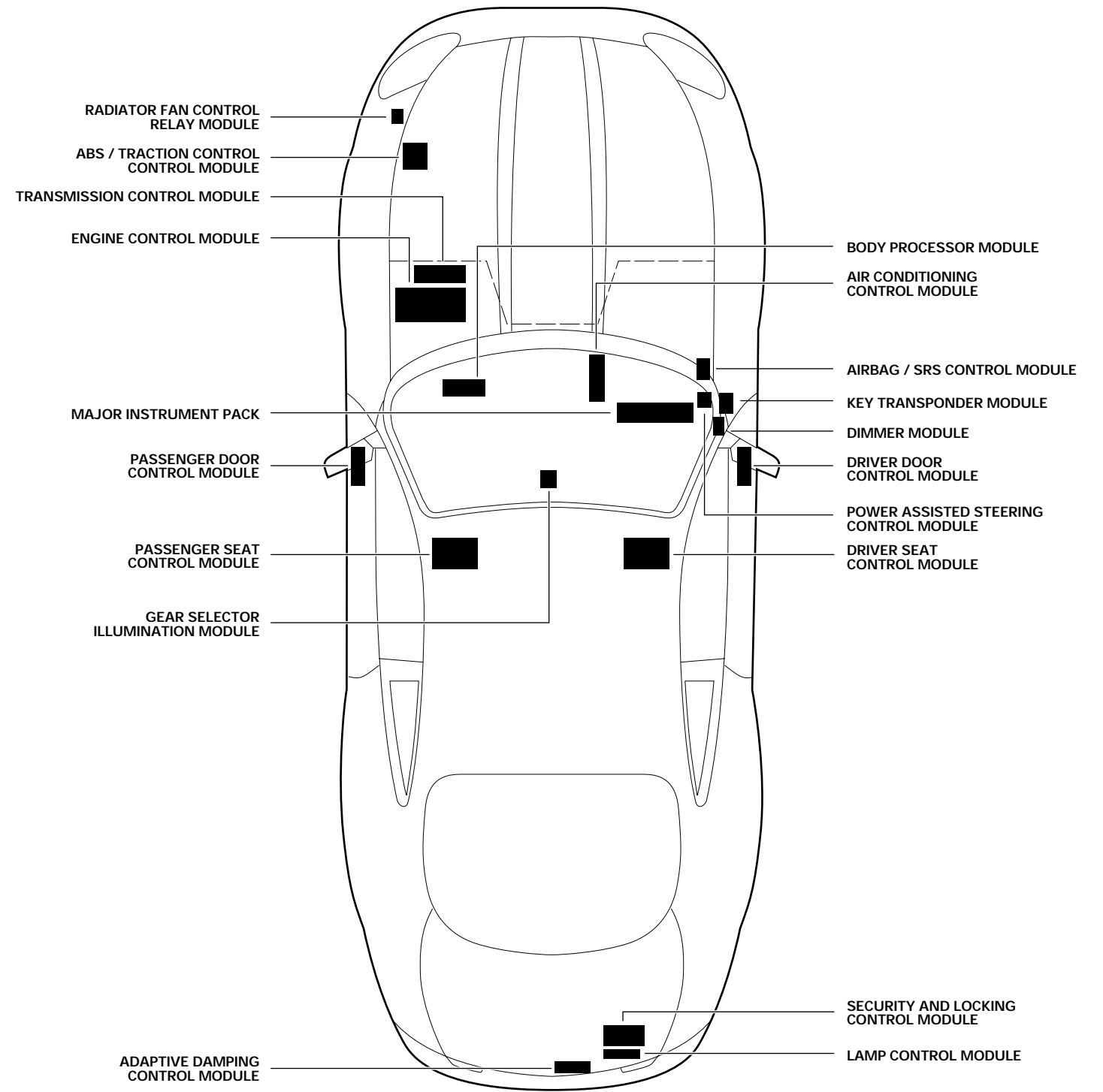
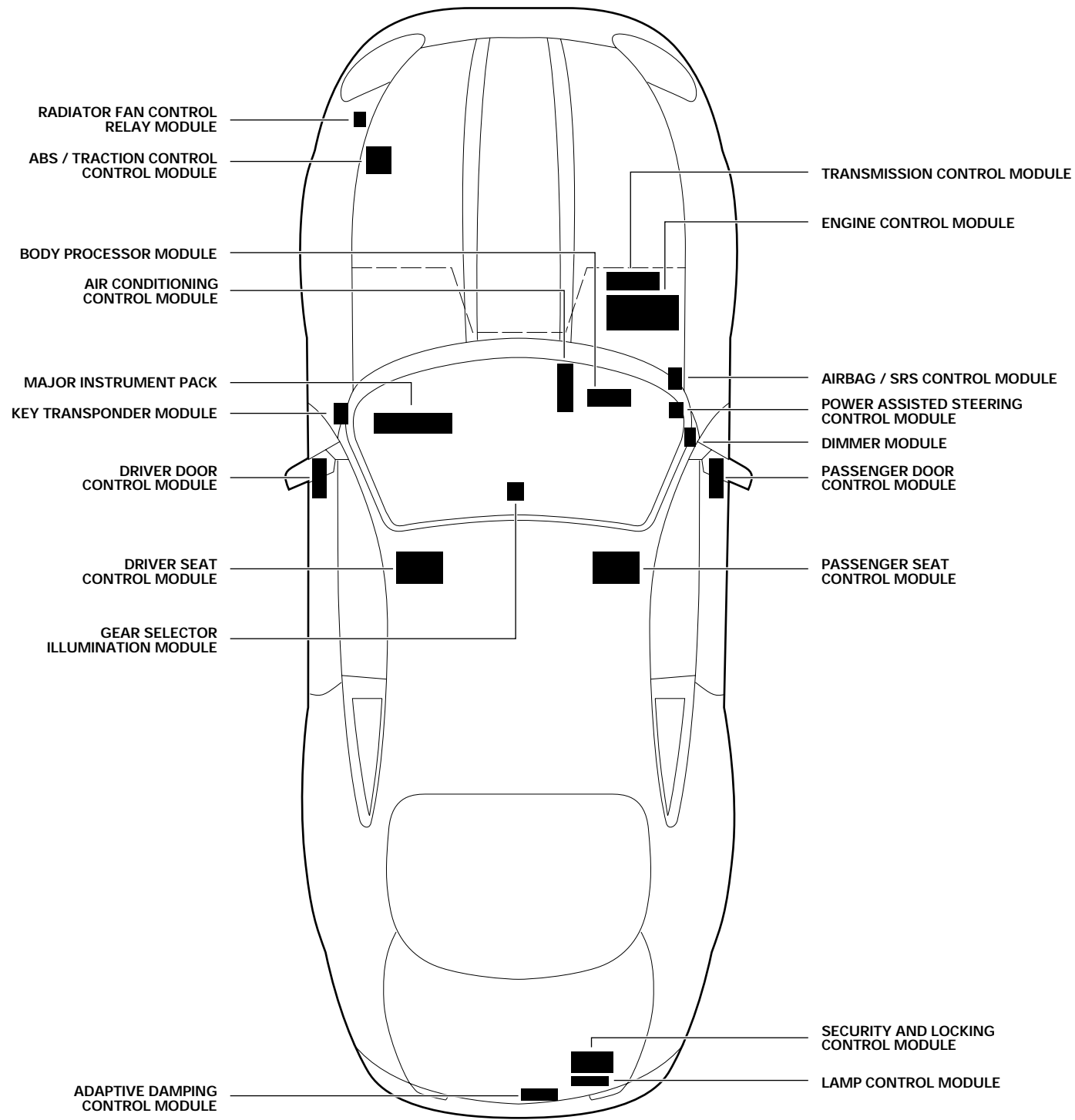



ABS / TRACTION CONTROL CONTROL MODULE

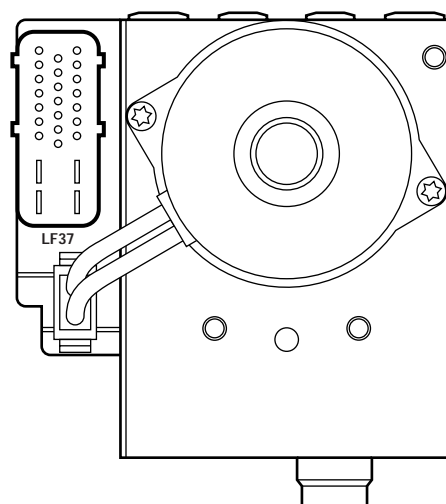

TOP

LF37 / 25-WAY / BLACK

17	18	19	20	21	22	23	24	25
W	R	UP	WU	P	U	—	B	WY
10	11	12	13	14	15	16	8	9
—	—	—	UB	R	G	RY	B	NR
1	2	3	4	5	6	7	—	—
UO	US	S	G	Y	Y	O	—	—

TRANSMISSION CONTROL MODULE: AJ26 N/A

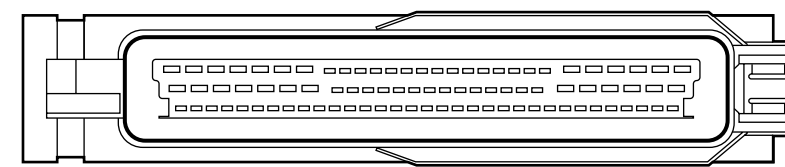

EM7

EM7 / 88-WAY / BLACK

28	27	26	25	24	23	22	21	20	19	18	17	16	15	14	13	12	11	10	9	8	7	6	5	4	3	2	1					
BY	—	ND	—	—	BRD	UY	BU	—	—	BS	—	U	BRD	N	US	RP	—	—	W	RB	—	B	OG	OK	—	RS	OU					
55	54	53	52	51	50	49	48	47	46	45	44	43	42	41	40	39	38	37	36	35	34	33	32	31	30	29						
WB	WB	RU	RY	OB	—	—	—	—	—	RG	R	—	G	—	—	—	—	Y	S	—	B	YP	YU	—	YB	OR						
88	87	86	85	84	83	82	81	80	79	78	77	76	75	74	73	72	71	70	69	68	67	66	65	64	63	62	61	60	59	58	57	56
—	—	Y	G	—	Y	G	—	—	—	—	—	—	—	—	—	—	—	—	—	—	—	—	—	—	—	—	—	—	—	—	—	

TRANSMISSION CONTROL MODULE: AJ26 SC

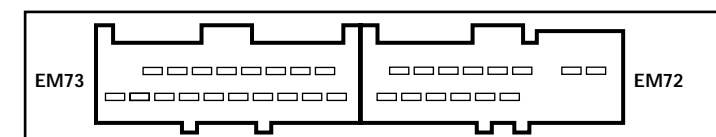

EM73 / 18-WAY / BLACK

23	24	25	26	27	28	29	30		
—	—	LGB	LGU	LGP	LGN	WB	B		
1	2	3	4	5	6	7	8	9	10
YU	BS	P	—	—	—	—	—	—	—

EM72 / 14-WAY / BLACK

33	34	35	36	37	38
B	BY	BU	BO	BN	BR
12	13	14	15	16	17
BG	BW	BK	BLG	BP	BS
L	H				
G	Y				

ENGINE CONTROL MODULE

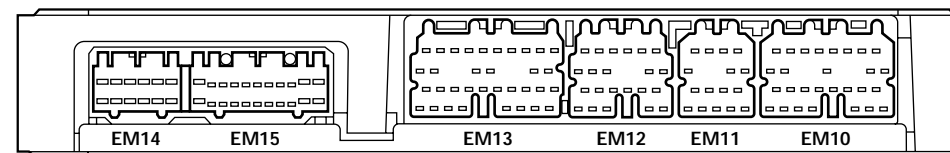

AJ26 N/A

EM14 / 12-WAY / WHITE

6	5	4	3	2	1
R	R	BK	WR	GY	GY
12	11	10	9	8	7
G	G	B	B	B	B

EM15 / 22-WAY / WHITE

11	10	9	8	7	6	5	4	3	2	1
B	—	RY	RG	BU	BW	BY	BO	PN	PU	PS
22	21	20	19	18	17	16	15	14	13	12
B	—	—	—	BS	BN	BG	BP	—	—	B

EM13 / 34-WAY / GREY

10	9	8	7	6	5	4	3	2	1
—	KW	—	—	—	—	OK	SP	W	KN
16	15	14	13	12	11				
WU	W	GR	PY	RW	PW				
26	25	24	23	22	21	20	19	18	17
LGU	LGW	LGO	LGK	UB	—	B	Y	S	N
34	33	32	31	30	29	28	27		
LPG	LGS	LGR	LGY	—	O	P	BG		

EM12 / 22-WAY / GREY

6	5	4	3	2	1
YW	WU	—	—	—	—
11	10	9	8	7	
—	RY	SG	SLG	—	
17	16	15	14	13	12
U	N	R	G	GY	UP
22	21	20	19	18	
BP	—	—	BY	BY	

EM11 / 16-WAY / GREY

4	3	2	1	
WU	P	—	SR	
7	6	5		
RG	GO	SG		
11	10	9	8	
U	G	UY	UW	
16	15	14	13	12
K	R	BG	BY	BG

EM10 / 28-WAY / GREY

8	7	6	5	4	3	2	1
—	—	O	WK	UN	ULG	UG	WR
13	12	11	10	9			
O	K	PG	US	NO			
21	20	19	18	17	16	15	14
UW	BG	—	—	Y	PK	G	OU
28	27	26	25	24	23	22	
Y	G	Y	G	—	BK	B	

AJ26 SC

EM14 / 12-WAY / WHITE

6	5	4	3	2	1
R	R	BK	WR	GY	GY
12	11	10	9	8	7
G	G	B	B	B	B

EM15 / 22-WAY / WHITE

11	10	9	8	7	6	5	4	3	2	1
B	—	—	—	BU	BW	BY	BO	PN	PU	PS
22	21	20	19	18	17	16	15	14	13	12
B	—	—	—	BS	BN	BG	BP	—	—	B

EM13 / 34-WAY / GREY

10	9	8	7	6	5	4	3	2	1
RY	KW	—	—	—	—	OK	SP	W	KN
16	15	14	13	12	11				
WU	W	GR	PY	RW	PW				
26	25	24	23	22	21	20	19	18	17
LGU	LGW	LGO	LGK	UB	—	B	Y	S	N
34	33	32	31	30	29	28	27		
LPG	LGS	LGR	LGY	—	O	P	BG		

EM12 / 22-WAY / GREY

6	5	4	3	2	1
YW	WU	YR	YN	YG	YU
11	10	9	8	7	
—	RY	SG	SLG	—	
17	16	15	14	13	12
U	N	R	G	GY	UP
22	21	20	19	18	
BP	—	—	BY	BY	

EM11 / 16-WAY / GREY

4	3	2	1	
WU	P	—	SR	
7	6	5		
RG	GO	SG		
11	10	9	8	
U	G	UY	UW	
16	15	14	13	12
K	R	BG	BY	BG

EM10 / 28-WAY / GREY

8	7	6	5	4	3	2	1
—	—	O	WK	UN	ULG	UG	WR
13	12	11	10	9			
O	K	PG	US	NO			
21	20	19	18	17	16	15	14
UW	BG	—	—	Y	PK	G	OU
28	27	26	25	24	23	22	
Y	G	Y	G	—	BK	B	



MAJOR INSTRUMENT PACK

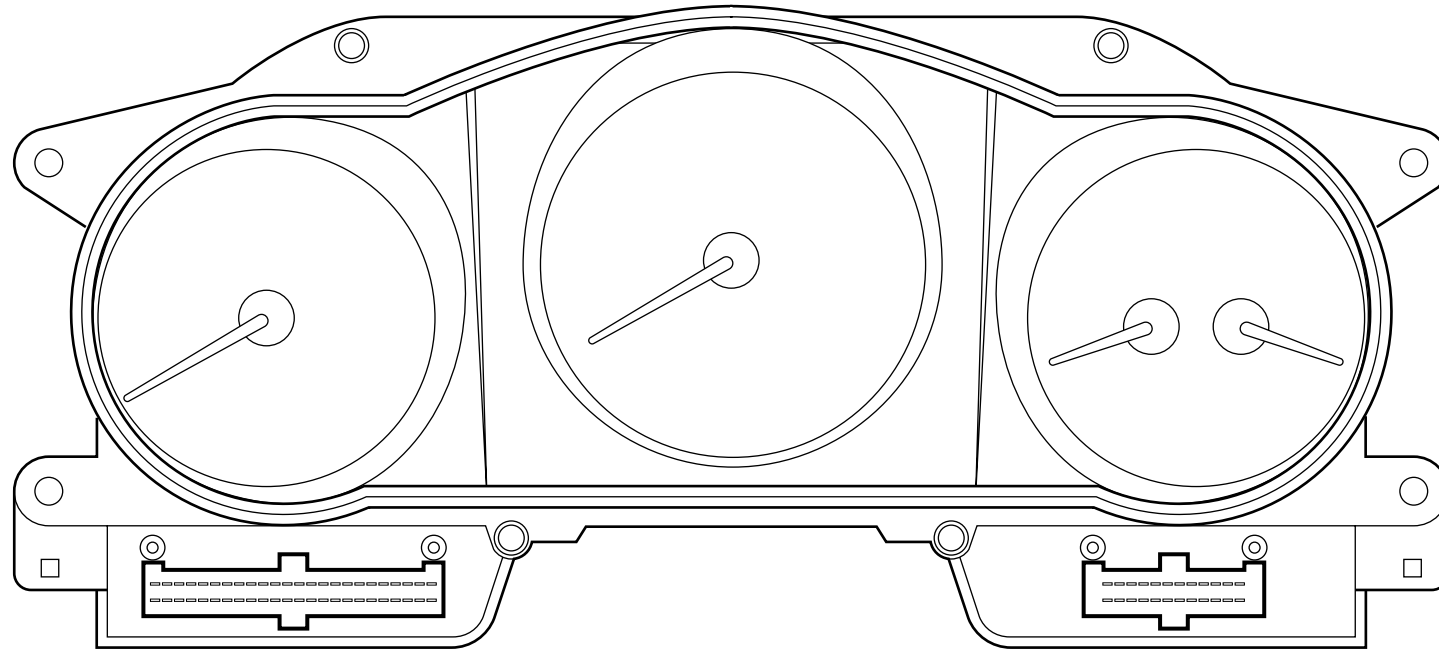

FC25

FC26

FC25 / 48-WAY / BLACK

1	2	3	4	5	6	7	8	9	10	11	12	13	14	15	16	17	18	19	20	21	22	23	24
BK	WG	RN	—	—	SO	—	—	—	SU	—	—	UY	R	—	—	—	—	S	U	—	—	Y	Y
25	26	27	28	29	30	31	32	33	34	35	36	37	38	39	40	41	42	43	44	45	46	47	48
NR	B	RO	RO	—	—	—	—	BR	—	Y	O	—	—	—	—	—	—	—	—	—	—	G	G

FC26 / 24-WAY / BLACK

1	2	3	4	5	6	7	8	9	10	11	12
RK	OW	PY	SG	OU	UB	ON	RG	RS	OB	RB	RU
13	14	15	16	17	18	19	20	21	22	23	24
BW	RW	OU	YW	OS	OG	OS	UW	RLG	SW	OP	UR

BODY PROCESSOR MODULE

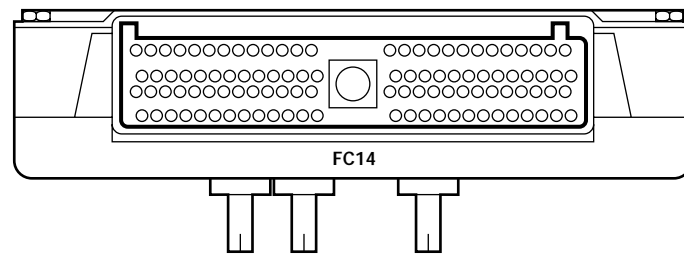

FC14

FC14 / 104-WAY / GREY

79	80	81	82	83	84	85	86	87	88	89	90	91	92	93	94	95	96	97	98	99	100	101	102	103	104
NG	NB	GR	GR	GB	U	S	ON	SK	YG	LGR	BG	BW	SU	YK	LGO	RS	PW	—	GB	PN	BR	PW	NY	B	NY
53	54	55	56	57	58	59	60	61	62	63	64	65	66	67	68	69	70	71	72	73	74	75	76	77	78
RK	RB	SP	UW	—	SB	PY	RY	KG	LGU	SW	—	BK	PJ	UR	US	OK	GS	SR	—	GO	RW	—	GK	GP	PG
27	28	29	30	31	32	33	34	35	36	37	38	39	40	41	42	43	44	45	46	47	48	49	50	51	52
GO	RW	S	U	SW	WN	RG	LGK	OU	LGW	LGR	OR	Y	WU	RW	UY	BLG	OY	UG	—	—	OG	—	GY	RW	BS
1	2	3	4	5	6	7	8	9	10	11	12	13	14	15	16	17	18	19	20	21	22	23	24	25	26
RY	GY	GK	GU	SO	YW	RU	—	—	—	—	—	—	UB	WO	RY	OS	YS	WLG	OG	—	—	—	—	—	—

NOTE: (NAS) PIN 13 NOT USED

SECURITY AND LOCKING CONTROL MODULE

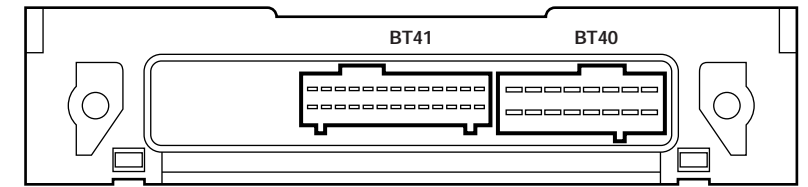

BT41 / 26-WAY / BLACK (NAS)

13	12	11	10	9	8	7	6	5	4	3	2	1
—	—	—	—	—	—	YP	—	RY	—	—	—	R
26	25	24	23	22	21	20	19	18	17	16	15	14
—	—	—	—	—	—	—	YR	—	—	—	—	—

BT40 / 16-WAY / BLACK

8	7	6	5	4	3	2	1
S	OG	NK	YW	GW	UG	OB	OR
16	15	14	13	12	11	10	9
U	NY	BK	BK	—	—	—	GR

BT41 / 26-WAY / BLACK (ROW)

13	12	11	10	9	8	7	6	5	4	3	2	1
—	—	—	BK	—	LGS	—	—	RY	—	—	—	—
26	25	24	23	22	21	20	19	18	17	16	15	14
YO	—	—	—	—	—	—	YR	—	—	—	—	—

DRIVER DOOR CONTROL MODULE

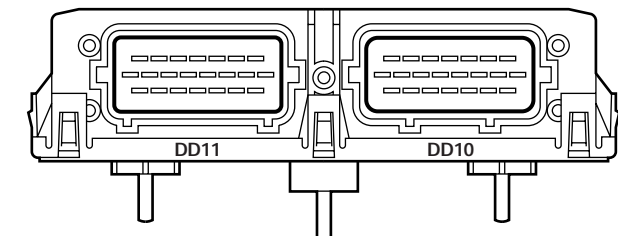

DD11 / 22-WAY / BLACK

7	6	5	4	3	2	1	
BP	KS	LGU	OU	SN	UG	OB	
15	14	13	12	11	10	9	8
WG	—	—	OY	—	YO	YN	—
22	21	20	19	18	17	16	
UN	UP	GY	—	—	OR	—	

DD10 / 22-WAY / BLUE

7	6	5	4	3	2	1	
OB	SU	SY	PN	PG	BY	N	
15	14	13	12	11	10	9	8
OU	GW	PO	PW	PB	BG	U	BK
22	21	20	19	18	17	16	
PK	PU	WU	BR	BO	B	S	

PASSENGER DOOR CONTROL MODULE

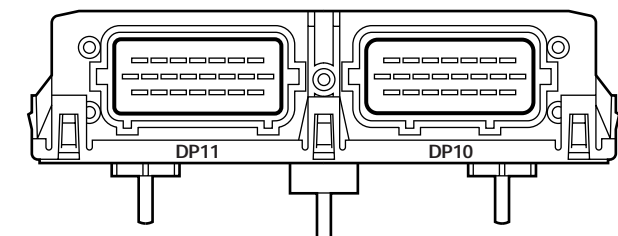

DP11 / 22-WAY / BLACK

7	6	5	4	3	2	1	
—	—	—	—	—	—	—	
15	14	13	12	11	10	9	8
—	—	—	—	—	—	—	—
22	21	20	19	18	17	16	
—	—	GY	—	—	—	—	

DP10 / 22-WAY / BLUE

7	6	5	4	3	2	1	
OB	SU	SY	PN	PG	PY	N	
15	14	13	12	11	10	9	8
OU	GW	PO	PW	PB	BG	U	BK
22	21	20	19	18	17	16	
PK	PU	WU	—	—	—	—	—

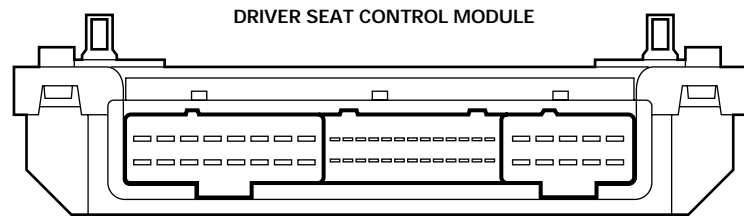

SD3 SD4 SD5

SD3 / 16-WAY / BLACK

9	10	11	12	13	14	15	16
UY	UW	KW	KY	GN	GP	GW	GY
1	2	3	4	5	6	7	8
PS	PO	OK	R	OB	OR	KS	KO

SD4 / 26-WAY / BLACK

14	15	16	17	18	19	20	21	22	23	24	25	26
WP	—	—	—	WB	—	—	—	—	—	—	—	—
1	2	3	4	5	6	7	8	9	10	11	12	13
WG	WU	B	—	W	WN	—	—	—	WR	WY	WO	—

SD5 / 10-WAY / BLACK

6	7	8	9	10
—	—	G	S	U
1	2	3	4	5
B	B	US	UO	NK

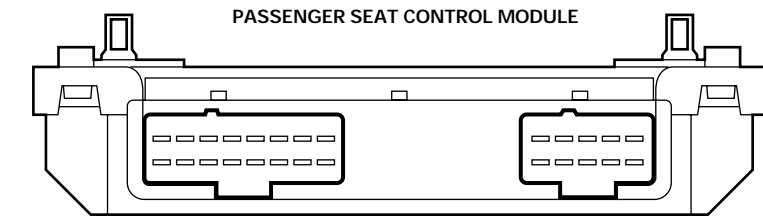

SP3 SP5

SP3 / 16-WAY / BLACK

9	10	11	12	13	14	15	16
UY	UW	KW	KY	GN	GP	GW	GY
1	2	3	4	5	6	7	8
PS	PO	OK	R	OB	OR	KS	KO

SP5 / 10-WAY / BLACK

6	7	8	9	10
—	—	G	S	U
1	2	3	4	5
B	B	US	UO	NK

AIRBAG / SRS CONTROL MODULE

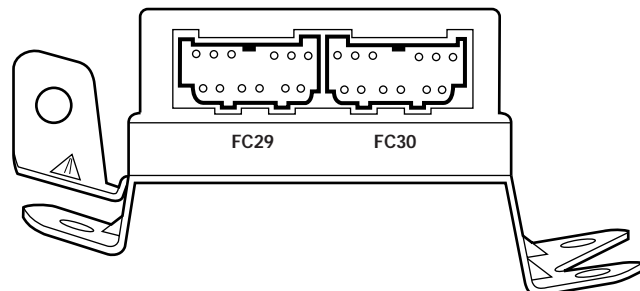

FC29 FC30

FC29 / 12-WAY / BLACK

7	8	9
WK	OW	OP
1	2	
—	—	
3	4	
—	BK	
5	6	
YW	R	
10	11	12
—	YU	ON

FC30 / 12-WAY / GREY

12	11	10
BK	RS	KU
6	5	
WK	RG	
4	3	
KP	KN	
9	8	7
KG	RW	RW
2	1	
RP	—	

ADAPTIVE DAMPING CONTROL MODULE

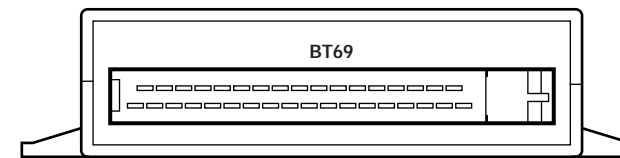

BT69

BT69 / 35-WAY / BLACK

19	20	21	22	23	24	25	26	27	28	29	30	31	32	33	34	35	
—	PB	UB	RB	—	ON	U	US	NS	K	—	OB	OW	OK	OY	OU	—	
1	2	3	4	5	6	7	8	9	10	11	12	13	14	15	16	17	18
SO	UP	UW	—	—	—	—	—	O	WR	—	OR	OG	OP	—	—	—	B

KEY TRANSPONDER MODULE

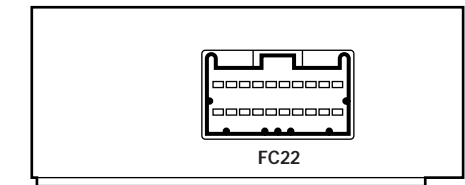

FC22

FC22 / 20-WAY / GREEN (NAS)

10	9	8	7	6	5	4	3	2	1
—	SU	—	—	O	—	—	—	—	—
20	19	18	17	16	15	14	13	12	11
—	—	—	Y	O	—	—	—	—	—

FC22 / 20-WAY / GREEN (ROW)

10	9	8	7	6	5	4	3	2	1
—	SU	OG	OR	O	—	NR	—	—	SB
20	19	18	17	16	15	14	13	12	11
—	—	—	Y	O	—	WO	WN	BK	—

AIR CONDITIONING CONTROL MODULE

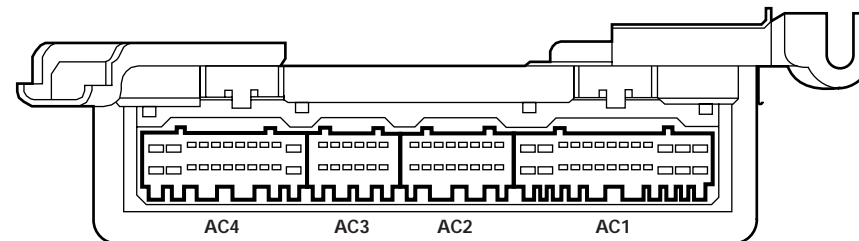

AC4 AC3 AC2 AC1

AC4 / 22-WAY / BLACK

12	13	14	15	16	17	18	19	20	21	22
WR	B	B	GW	OU	UB	LGW	BW	BK	O	—
1	2	3	4	5	6	7	8	9	10	11
WP	GY	WN	WU	NY	PY	UG	P	UN	K	—

AC3 / 12-WAY / GREY

7	8	9	10	11	12
SY	SR	—	WP	UB	KU
1	2	3	4	5	6
ULG	S	SG	SB	OY	UG

AC2 / 16-WAY / GREY

9	10	11	12	13	14	15	16
OU	OR	YG	—	UY	—	UK	GP
1	2	3	4	5	6	7	8
OP	RG	YW	—	SU	SG	US	GO

AC1 / 26-WAY / GREY

14	15	16	17	18	19	20	21	22	23	24	25	26
—	—	LGN	RW	LGP	RU	SR	Y	NR	—	—	UR	GU
1	2	3	4	5	6	7	8	9	10	11	12	13
RLG	U	UY	PS	LGR	RY	PR	PY	RB	—	—	UW	UO

LAMP CONTROL MODULE

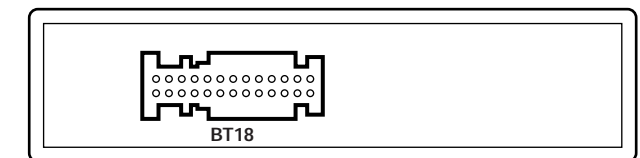

BT18

BT18 / 26-WAY / YELLOW

1	2	3	4	5	6	7	8	9	10	11	12	13
—	—	—	—	—	—	—	—	—	—	—	—	—
14	15	16	17	18	19	20	21	22	23	24	25	26
UP	UO	RY	RK	RU	UB	UW	RO	RG	RW	WG	R	BK



NOTE: RELAY COLORS ARE WRITTEN AS CASE COLOR (STRIPE) / CONNECTOR COLOR. FOR EXAMPLE, BLACK (BLUE) / BLUE INDICATES A RELAY HAVING A BLACK CASE WITH A BLUE STRIPE AND A BLUE CONNECTOR. IF THERE IS NO COLOR SHOWN IN PARENTHESES, THE RELAY CASE DOES NOT HAVE A STRIPE. SOME RELAYS CONNECT DIRECTLY TO A FUSE BOX BUS. THE CONNECTOR COLOR FOR THESE RELAYS IS IDENTIFIED AS "BUS".

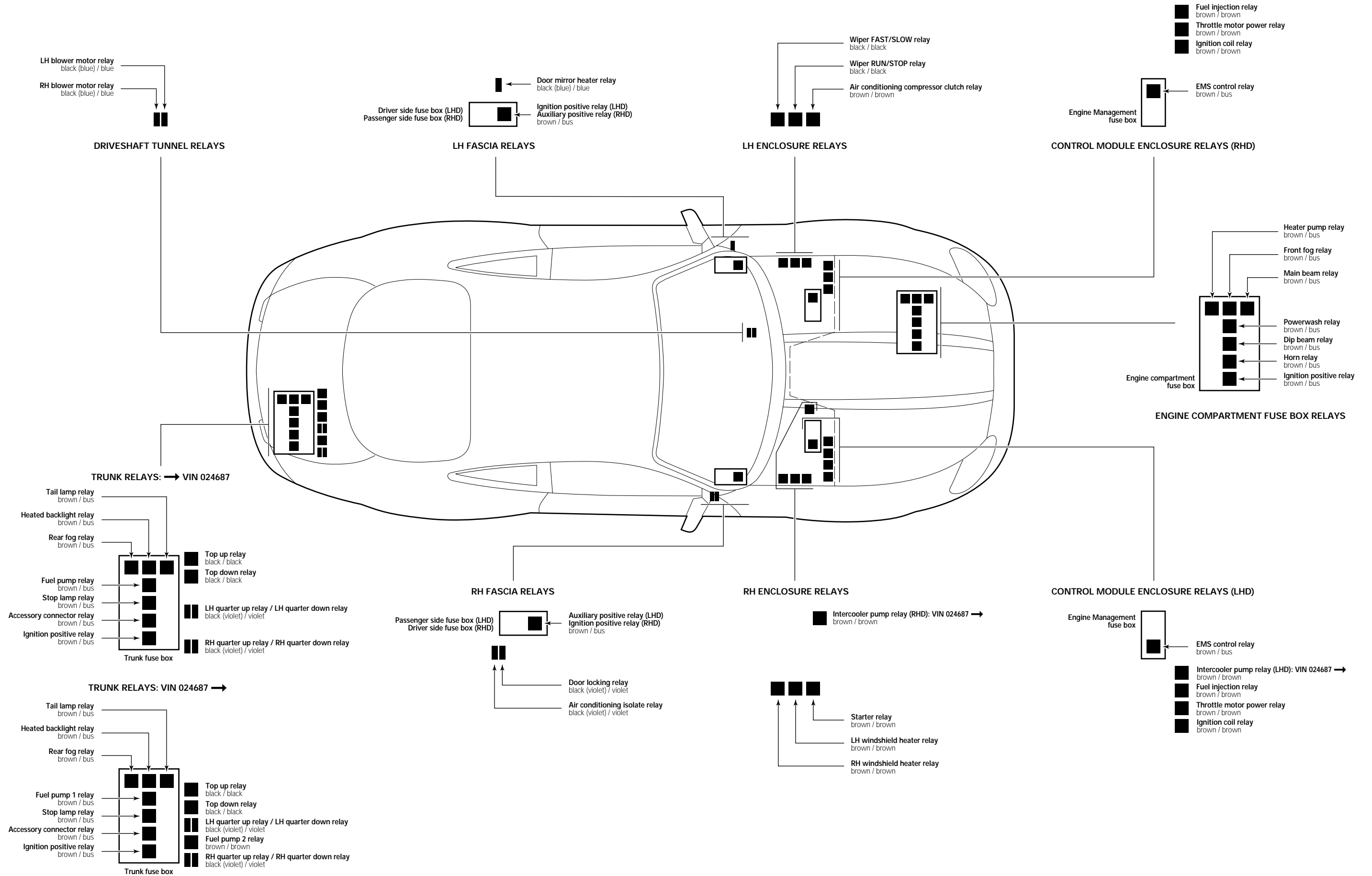

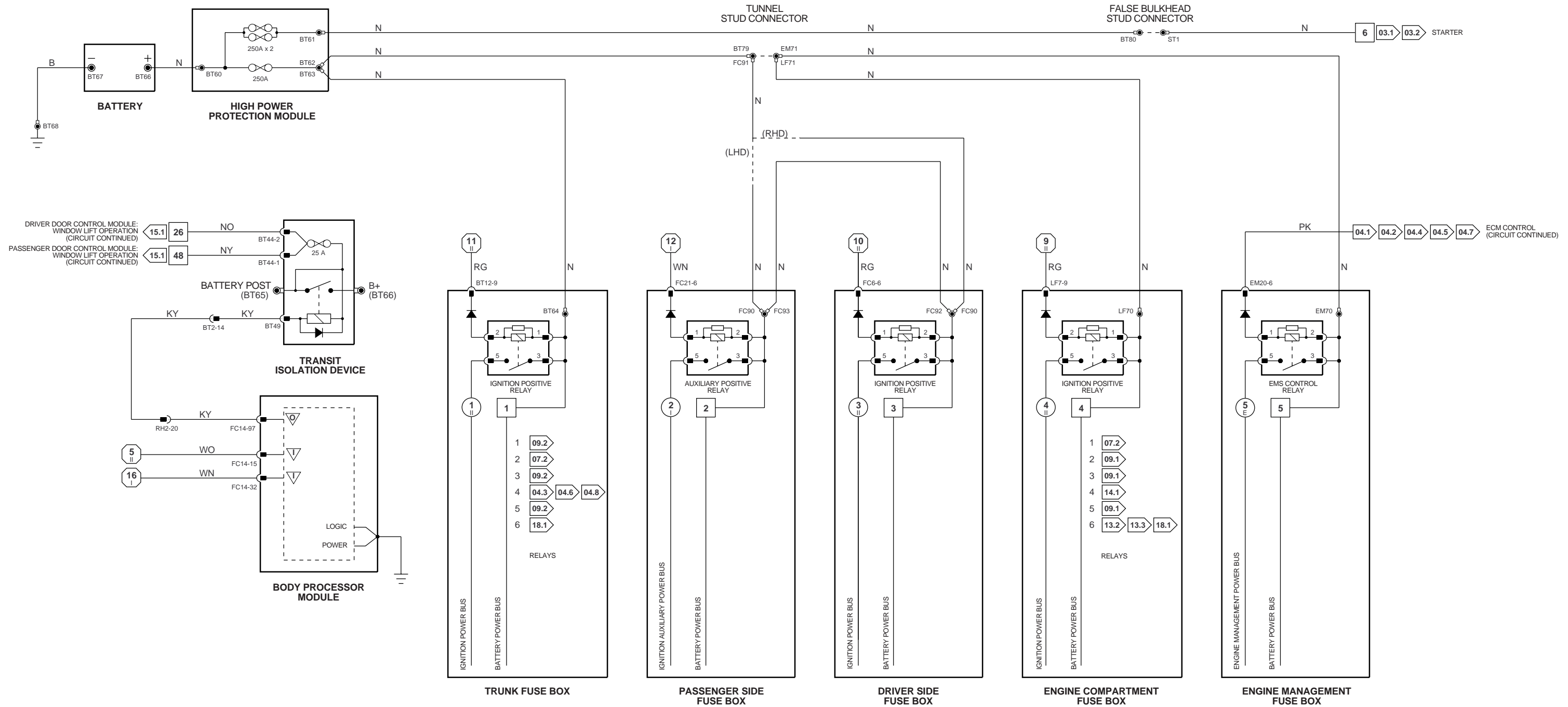
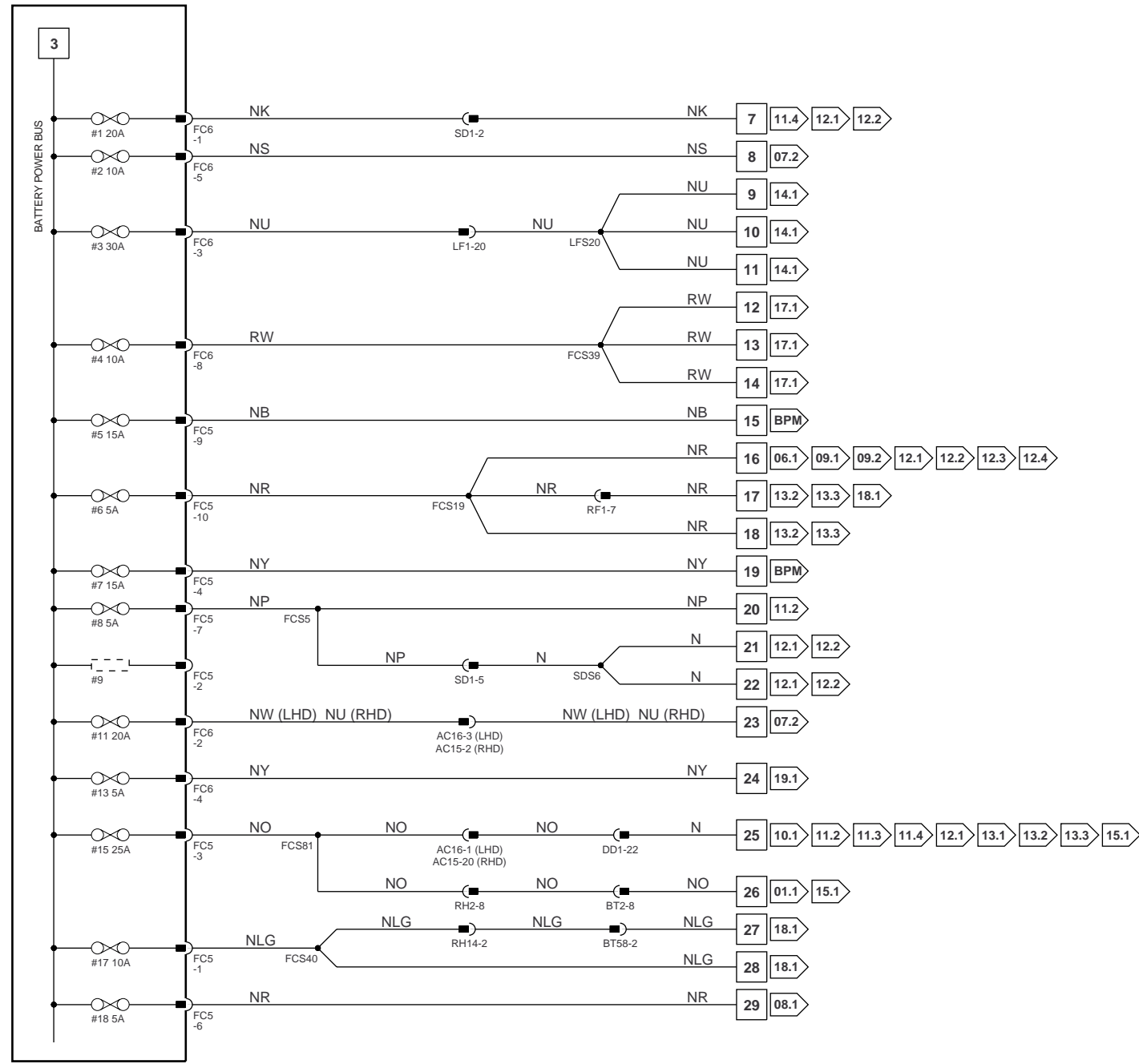
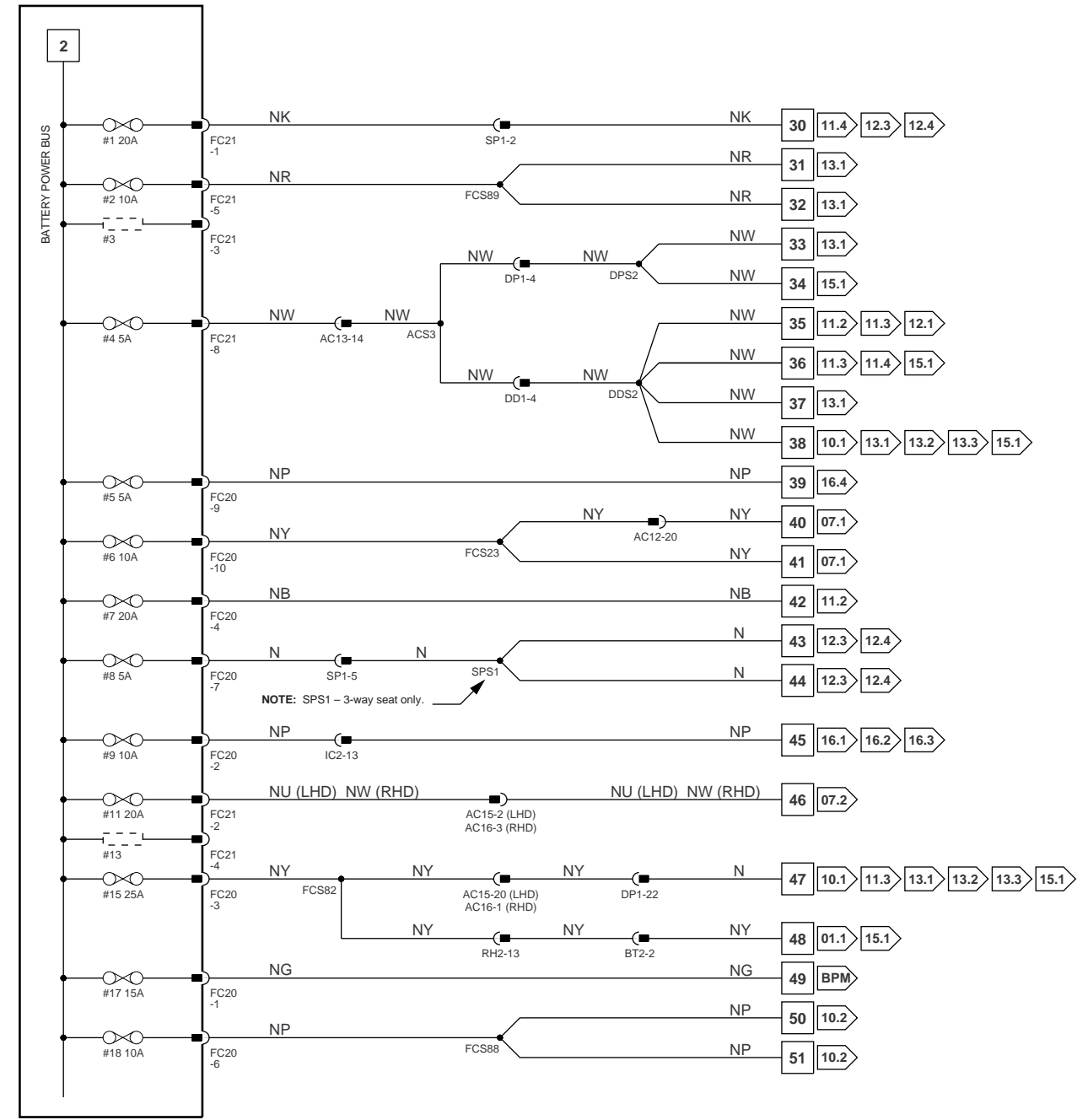

Fig. 01.1 Fig. 01.2 Fig. 01.3 Fig. 01.4 Fig. 01.5

VARIANT: All Vehicles
 VIN RANGE: 018108 →
 DATE OF ISSUE: FEBRUARY 1998



DRIVER SIDE FUSE BOX



PASSENGER SIDE FUSE BOX

BPM NOTE: Body Processor Module appears in numerous Figures.

	<p>1 - 6 Fig. 01.1</p> <p>7 - 51 Fig. 01.2</p> <p>52 - 81 Fig. 01.3</p>	<p>6 - 38 Fig. 01.4</p> <p>39 - 55 Fig. 01.5</p>	<p>1 - 18 Fig. 02.1</p>	<p>V Input</p> <p>▽ Signal Ground (SG)</p>	<p>▽ Output</p> <p>▽ CAN (Network)</p>	<p>▽ Serial and Encoded Communications</p> <p>▽ SCP Network</p>	<p>VARIANT: All Vehicles</p> <p>VIN RANGE: 018108 →</p> <p>DATE OF ISSUE: SEPTEMBER 1997</p>
--	---	--	-------------------------	--	--	---	--

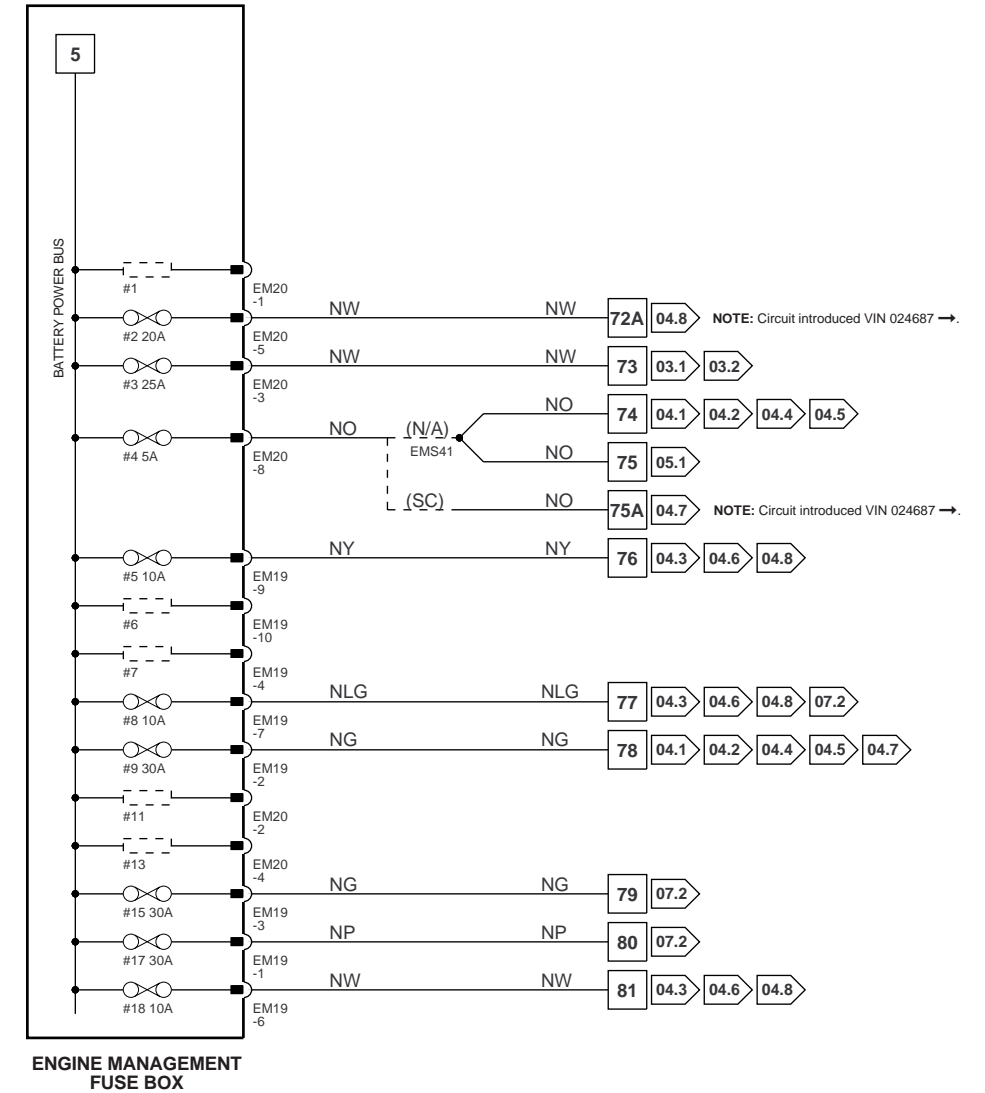
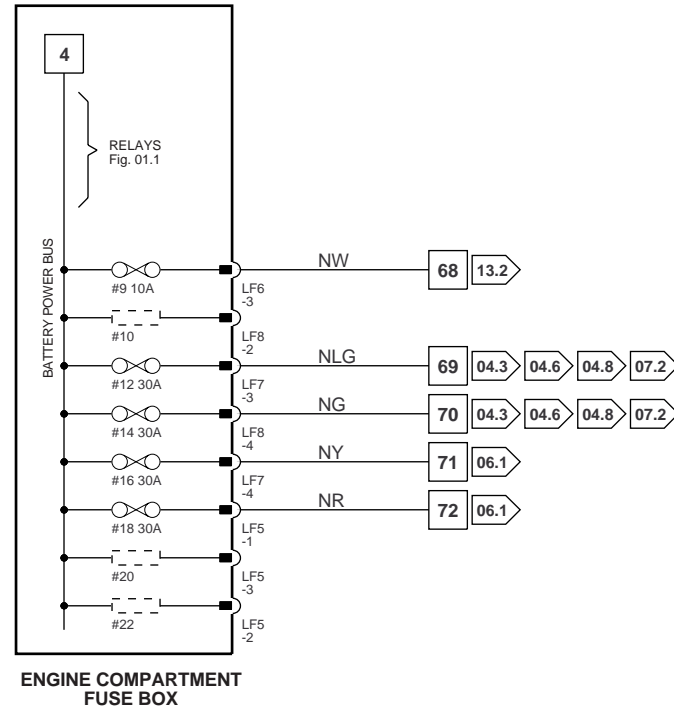
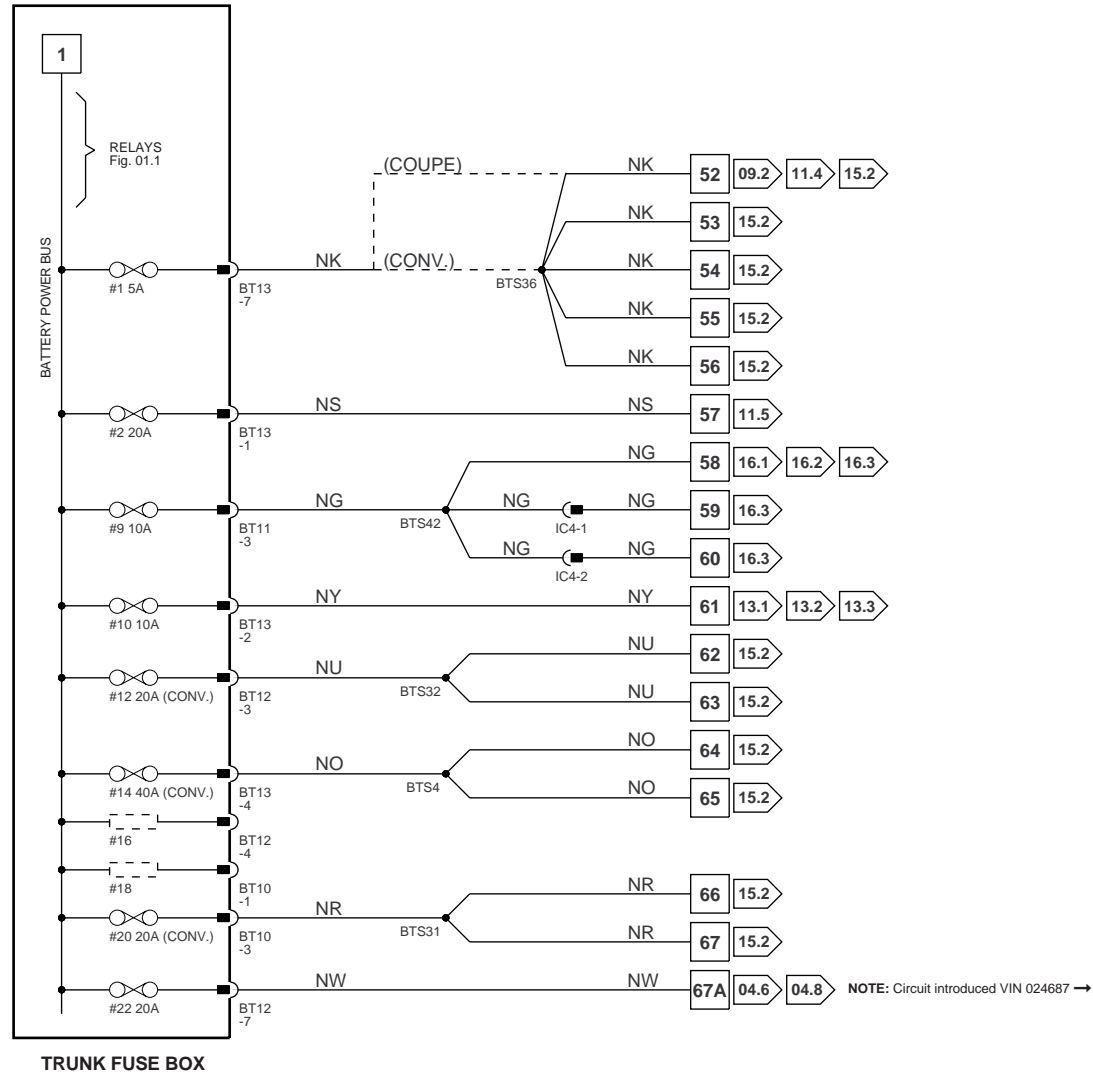

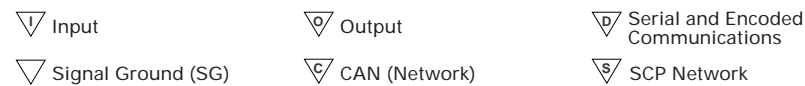
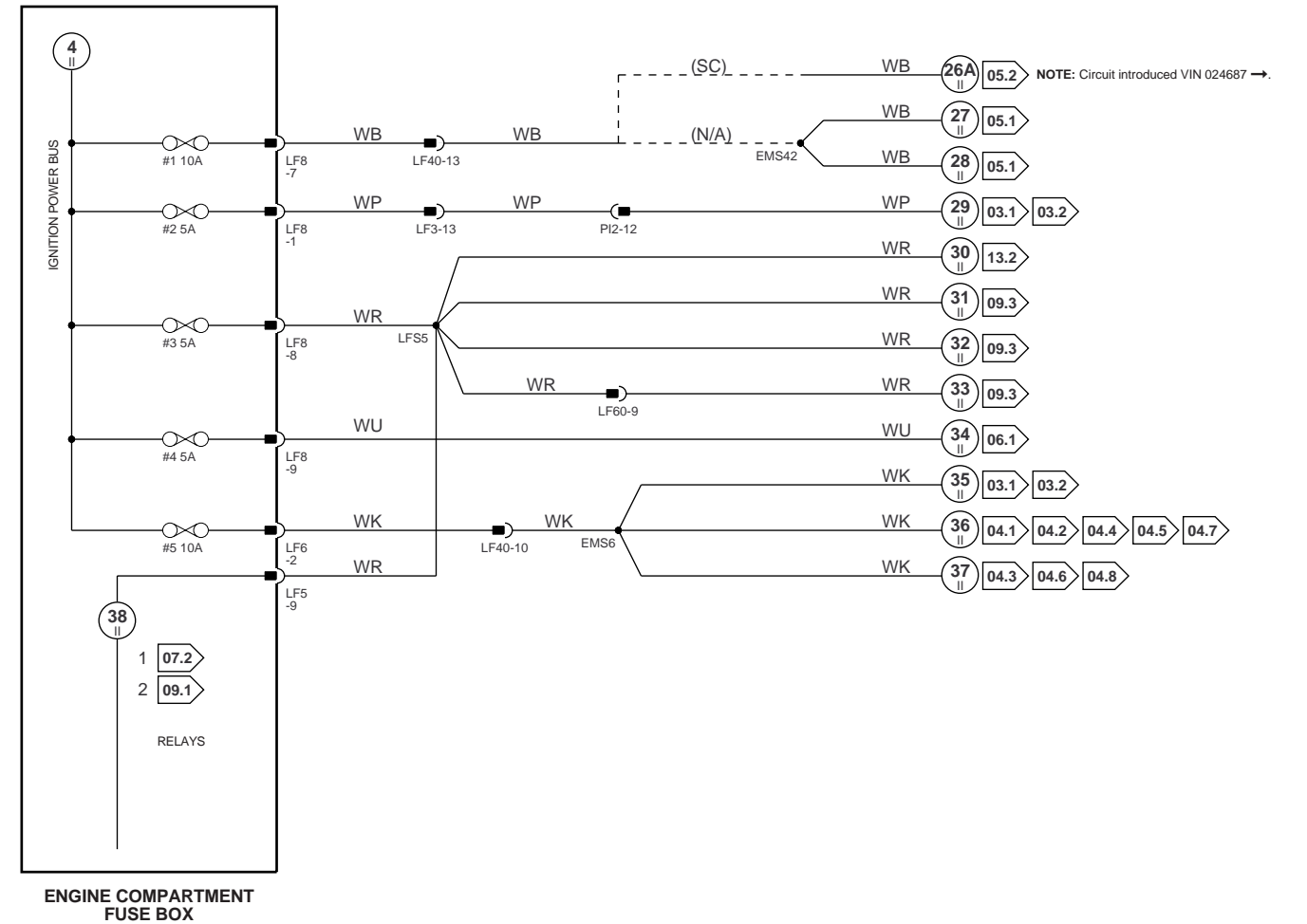
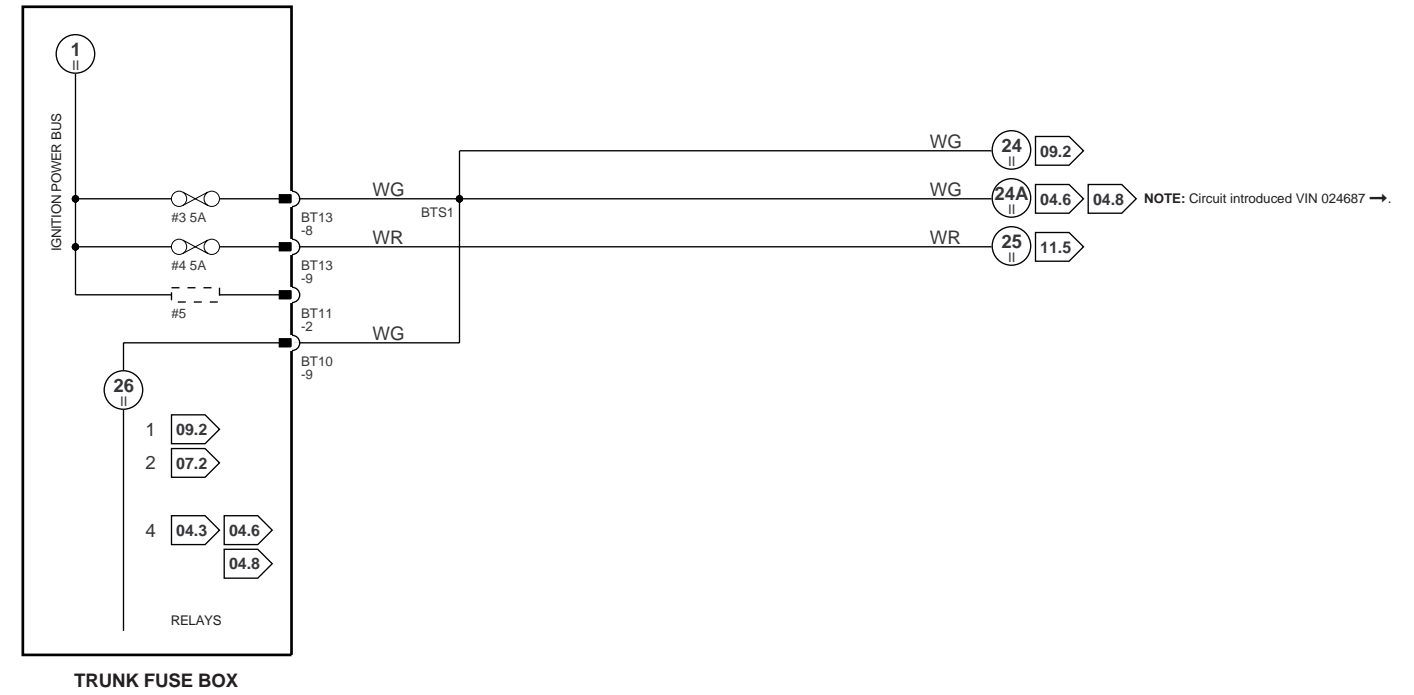
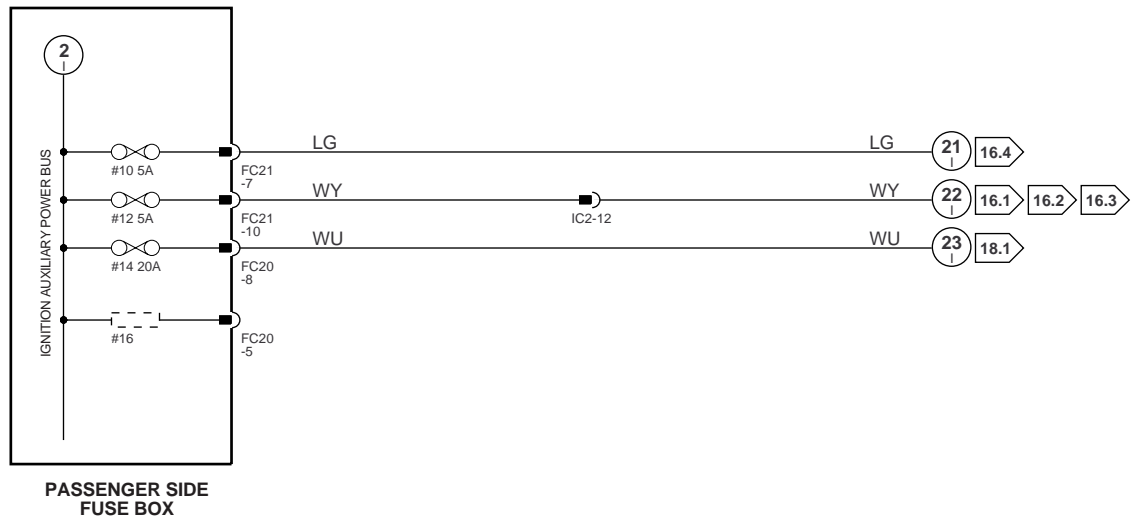
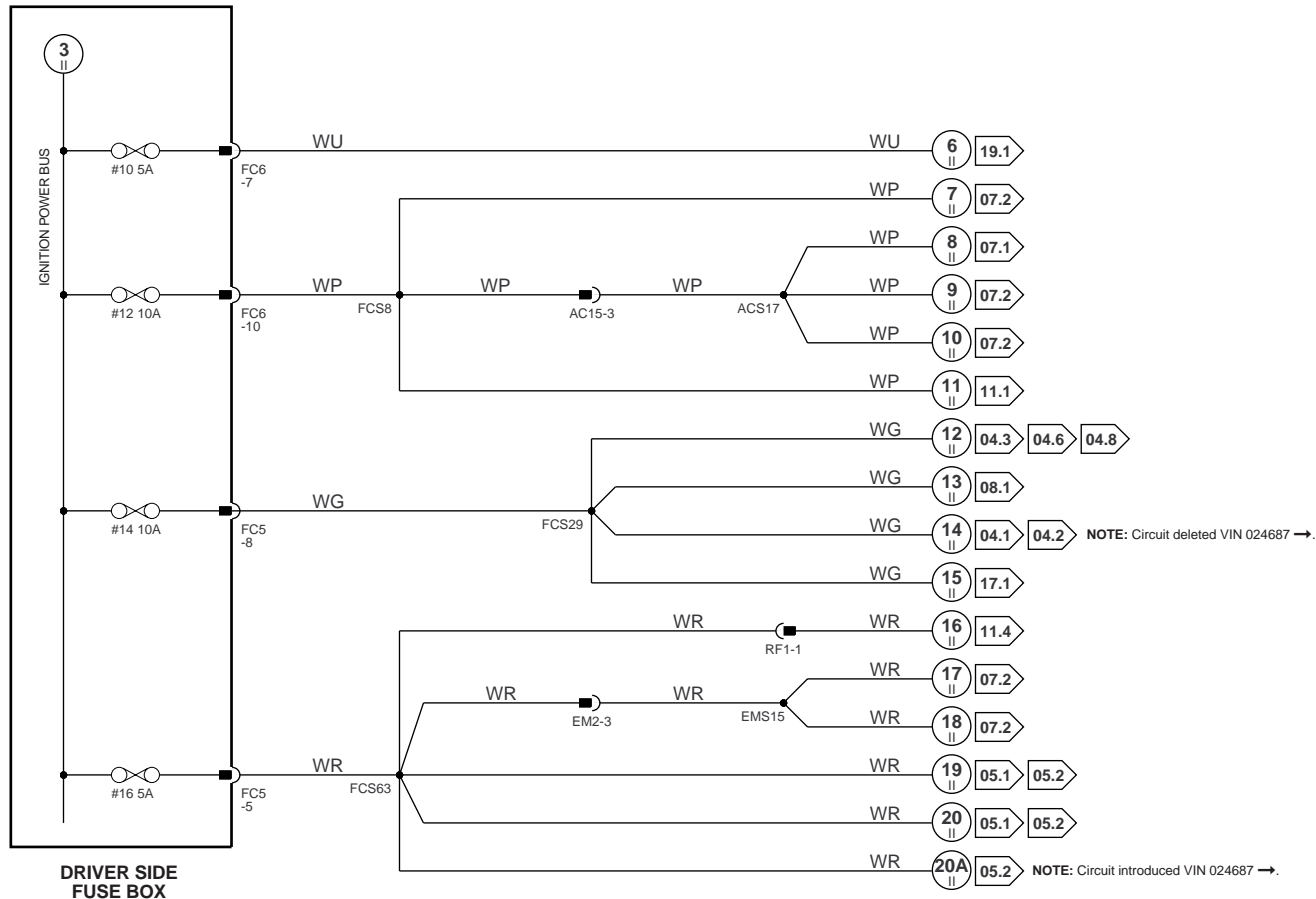

VARIANT: All Vehicles
 VIN RANGE: 018108 →
 DATE OF ISSUE: FEBRUARY 1998

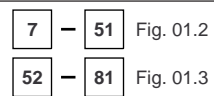
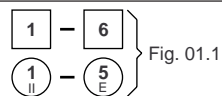
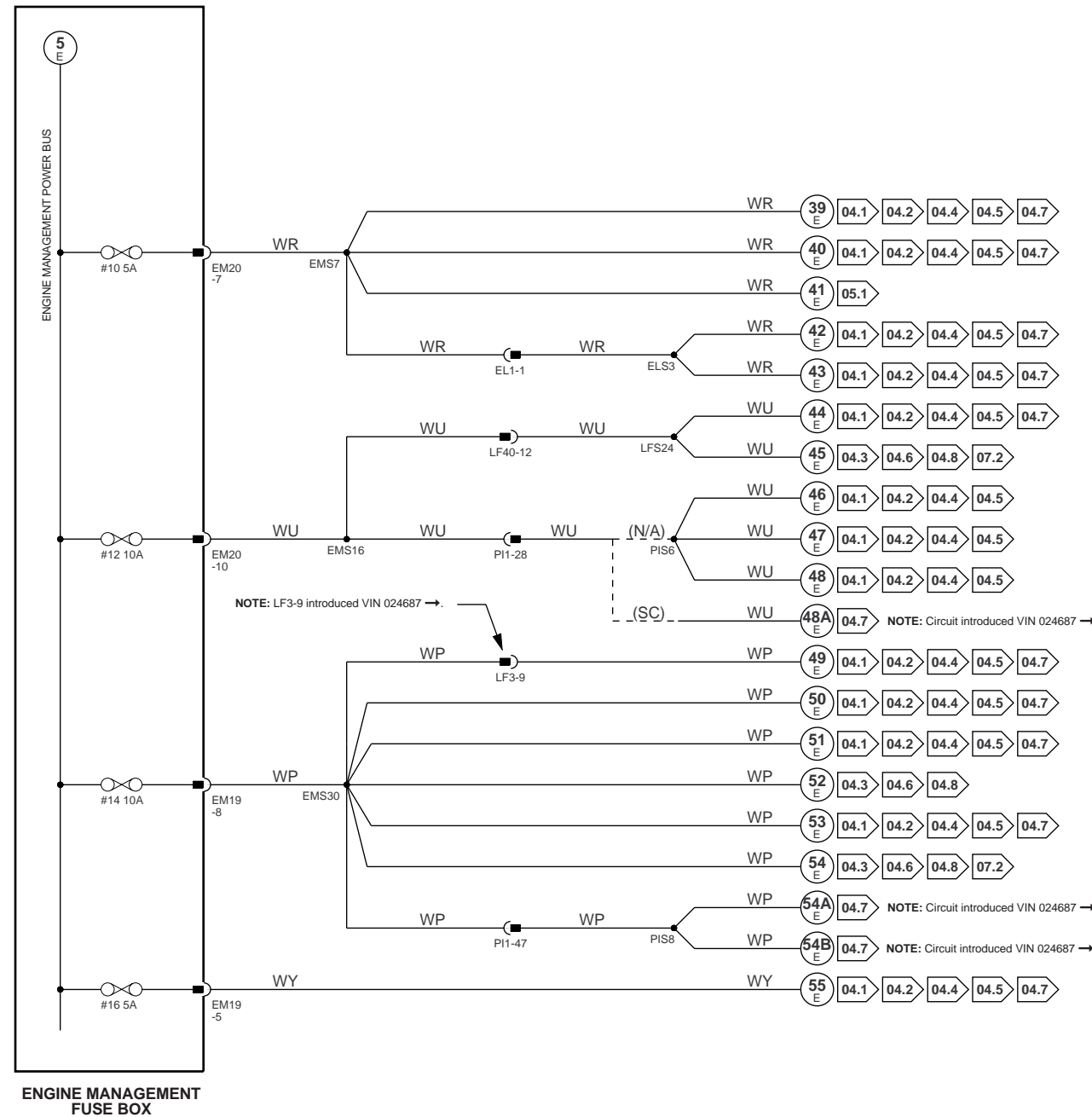

▽ Input

▽ Output

▽ Serial and Encoded Communications

▽ Signal Ground (SG)

▽ CAN (Network)

▽ SCP Network

VARIANT: All Vehicles
 VIN RANGE: 018108 →
 DATE OF ISSUE: FEBRUARY 1998

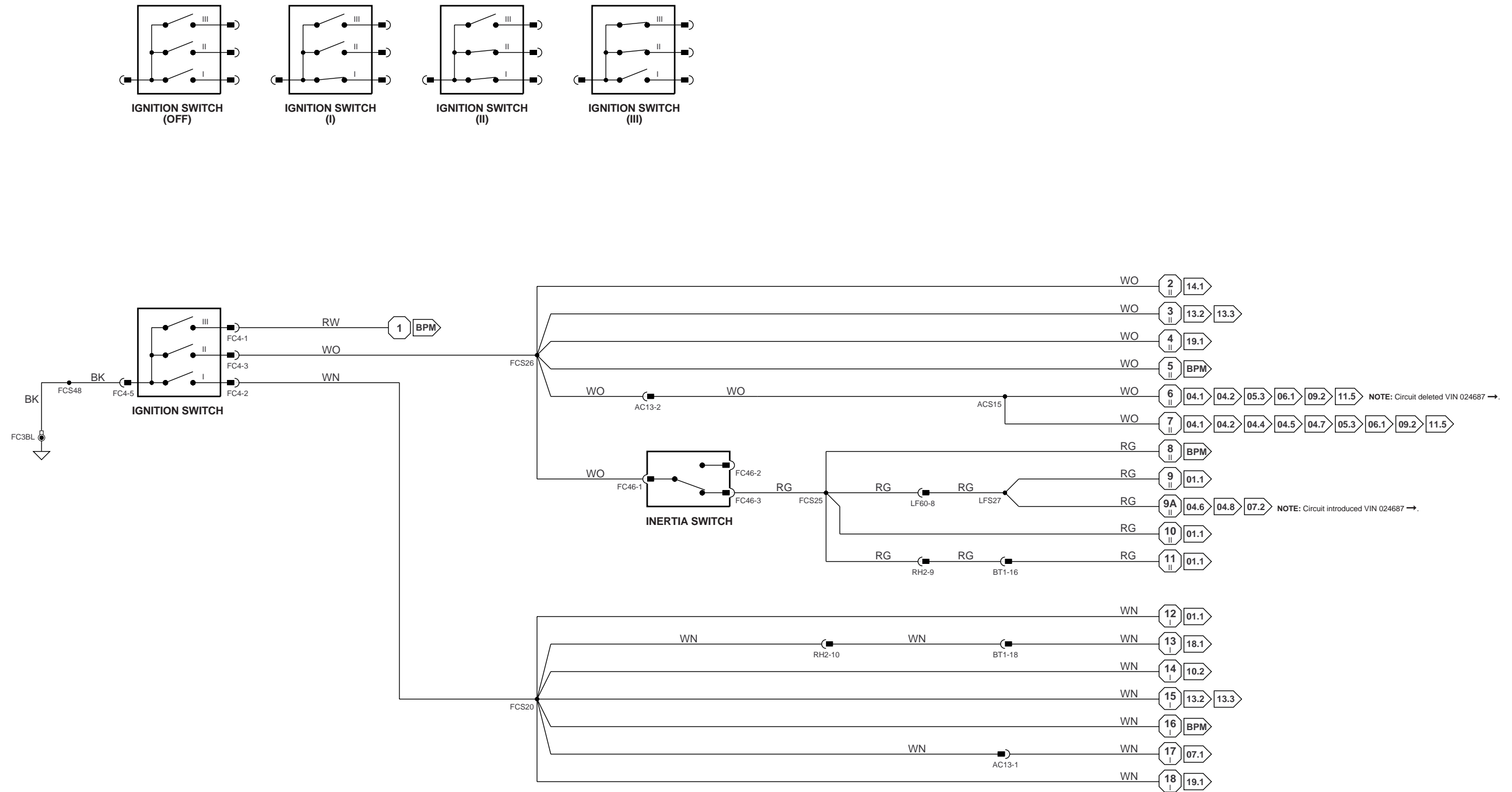

BPM NOTE: Body Processor Module appears in numerous Figures.

	<p>1 - 6 } Fig. 01.1</p> <p>1 - 5 } Fig. 01.1</p> <p>7 - 51 } Fig. 01.2</p> <p>52 - 81 } Fig. 01.3</p> <p>6 - 38 } Fig. 01.4</p> <p>39 - 55 } Fig. 01.5</p> <p>1 - 18 } Fig. 02.1</p>	<p>V Input</p> <p>▽ Signal Ground (SG)</p> <p>▽ Output</p> <p>▽ CAN (Network)</p> <p>▽ Serial and Encoded Communications</p> <p>▽ SCP Network</p>	<p>VARIANT: All Vehicles</p> <p>VIN RANGE: 018108 →</p> <p>DATE OF ISSUE: FEBRUARY 1998</p>
--	---	---	---

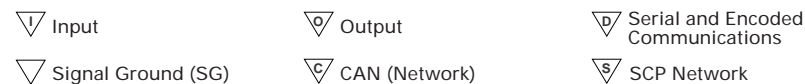
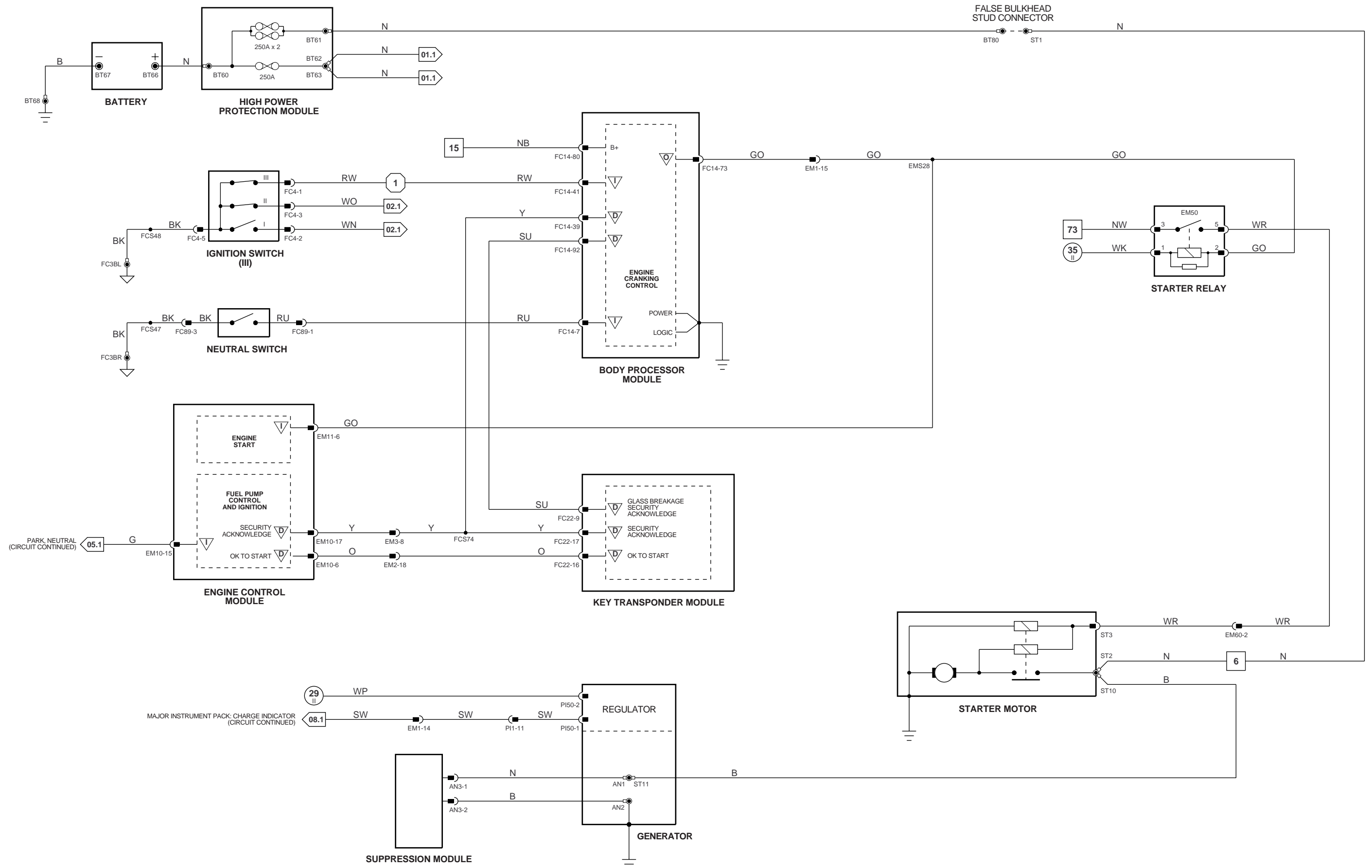

VARIANT: AJ26 N/A Vehicles
 VIN RANGE: 018108 →
 DATE OF ISSUE: FEBRUARY 1998

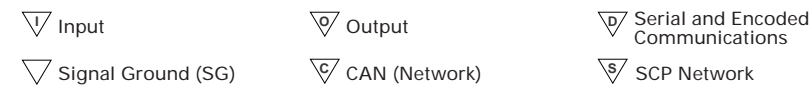
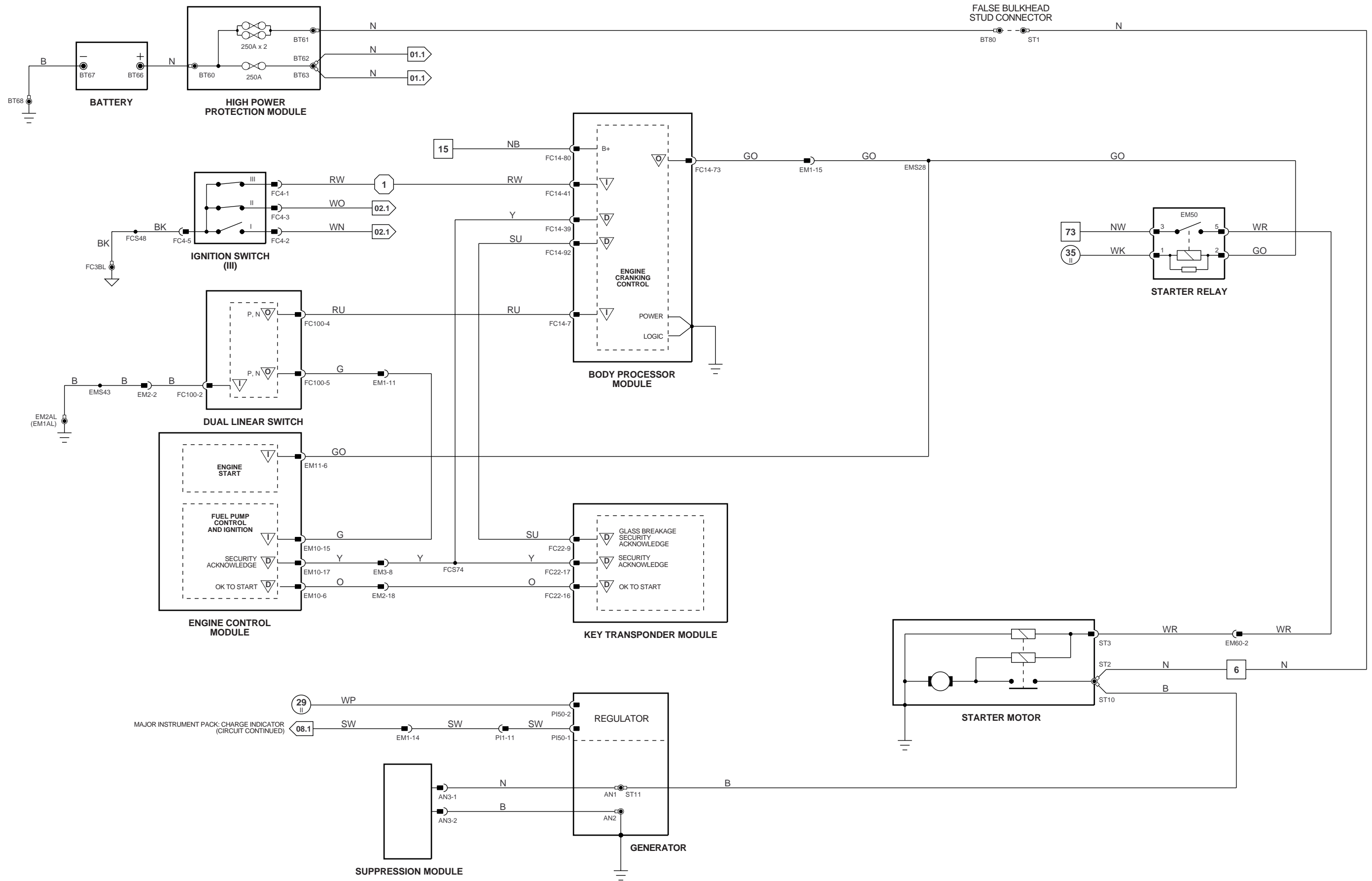

VARIANT: AJ26 SC Vehicles
 VIN RANGE: 024687 →
 DATE OF ISSUE: FEBRUARY 1998

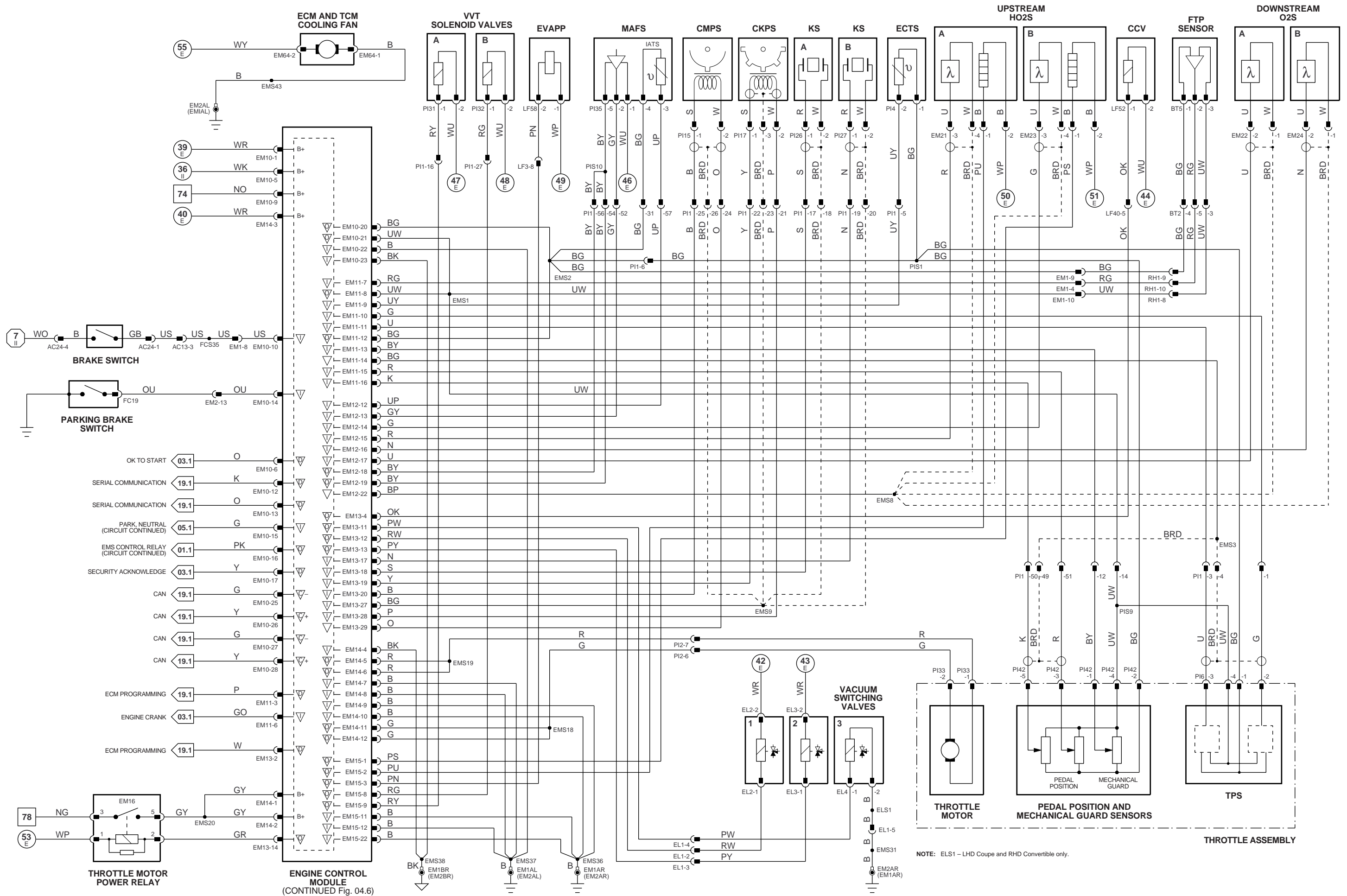

NOTE: ELS1 - LHD Coupe and RHD Convertible only.



VARIANT: AJ26 N/A NAS Vehicles
 VIN RANGE: 024687 →
 DATE OF ISSUE: FEBRUARY 1998

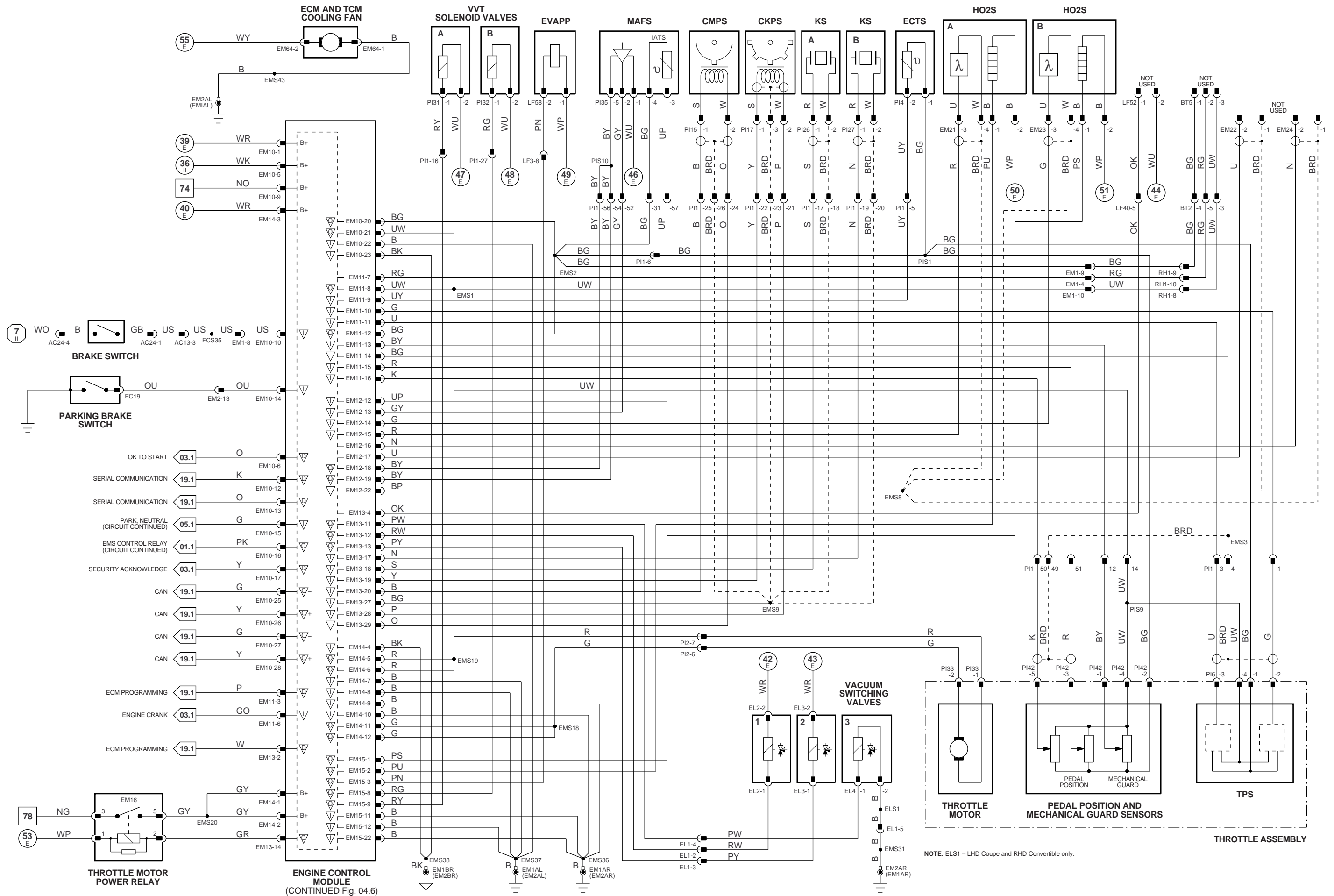

NOTE: ELS1 - LHD Coupe and RHD Convertible only.

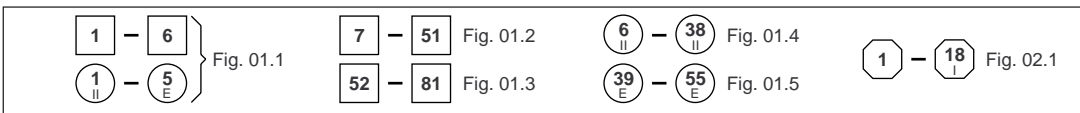

VARIANT: AJ26 N/A ROW Vehicles
 VIN RANGE: 024687 →
 DATE OF ISSUE: FEBRUARY 1998

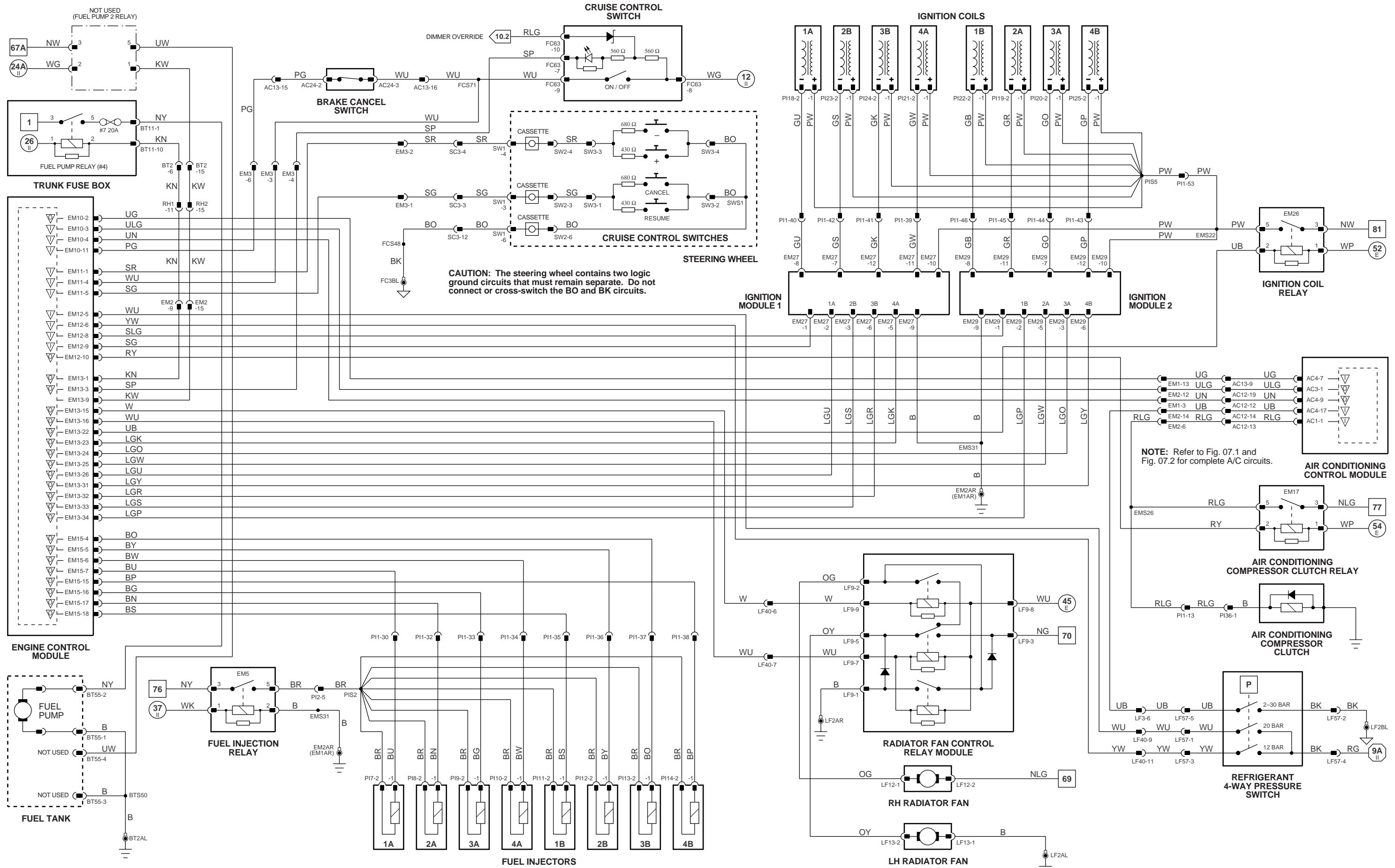

NOTE: ECM power supplies and grounds shown on Fig. 04.4 and Fig. 04.5.

<p>Fig. 01.1</p>	<p>Fig. 01.2 Fig. 01.3</p>	<p>Fig. 01.4 Fig. 01.5</p>	<p>Fig. 02.1</p>	<p>▽ Input</p> <p>▽ Signal Ground (SG)</p>	<p>▽ Output</p> <p>▽ CAN (Network)</p>	<p>▽ Serial and Encoded Communications</p> <p>▽ SCP Network</p>	<p>VARIANT: AJ26 N/A Vehicles</p> <p>VIN RANGE: 024687 →</p> <p>DATE OF ISSUE: FEBRUARY 1998</p>
------------------	--------------------------------	--------------------------------	------------------	--	--	---	--

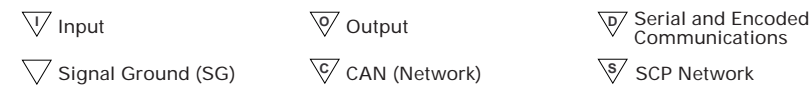
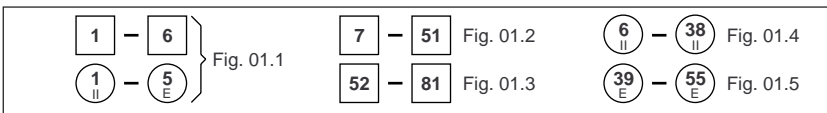
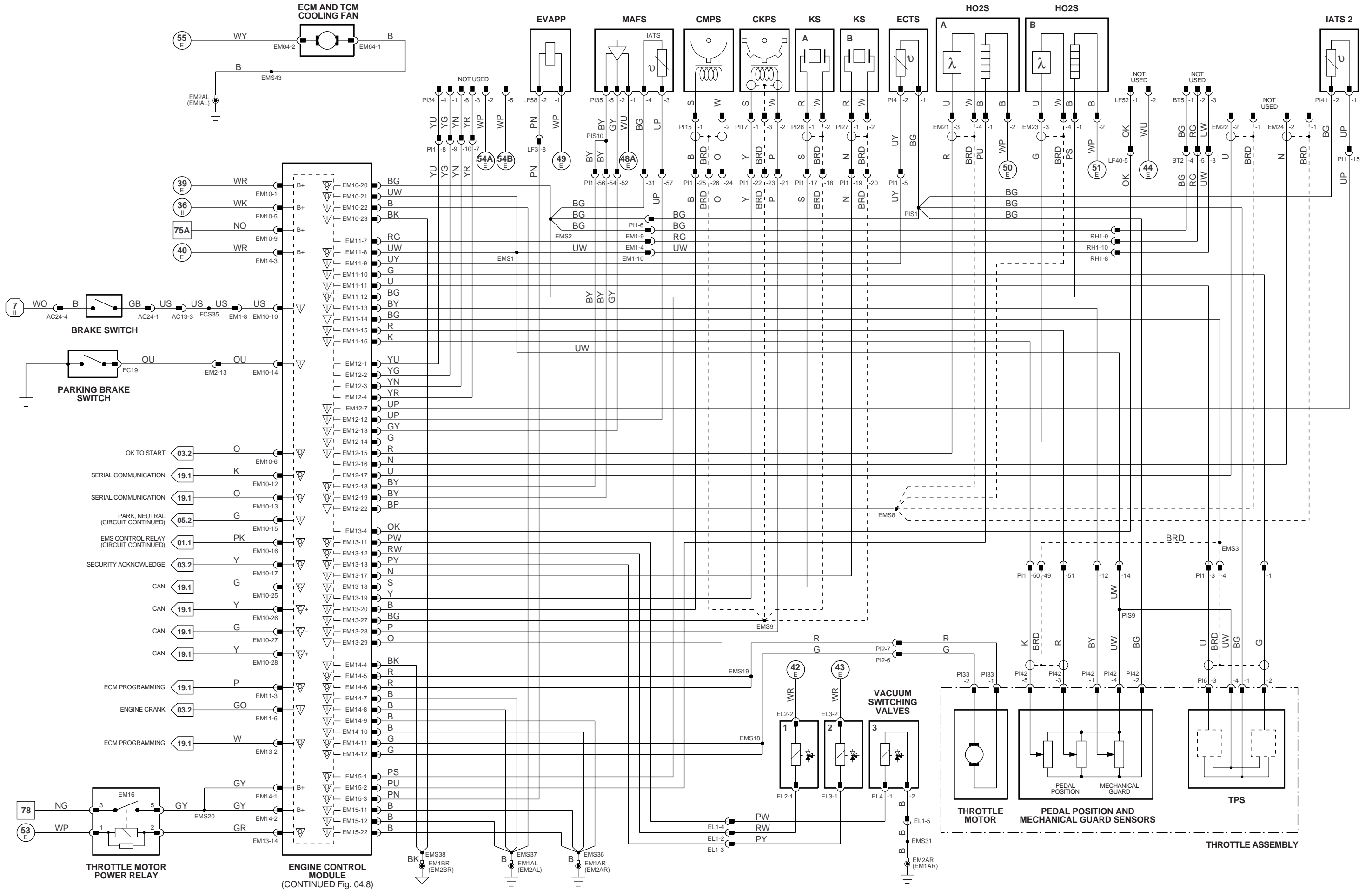

VARIANT: AJ26 SC ROW Vehicles
 VIN RANGE: 024687 →
 DATE OF ISSUE: FEBRUARY 1998

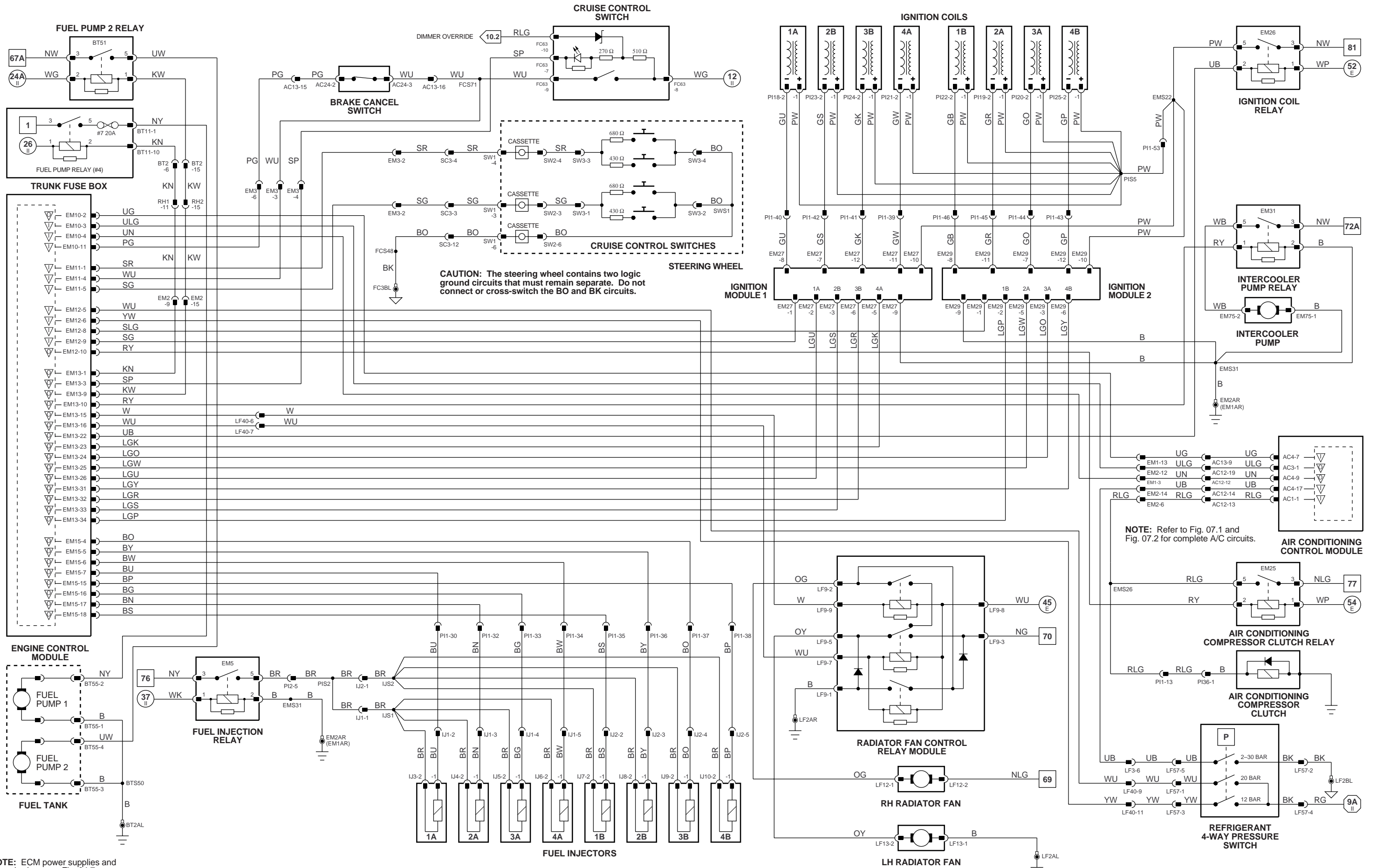

NOTE: ECM power supplies and grounds shown on Fig. 04.7.

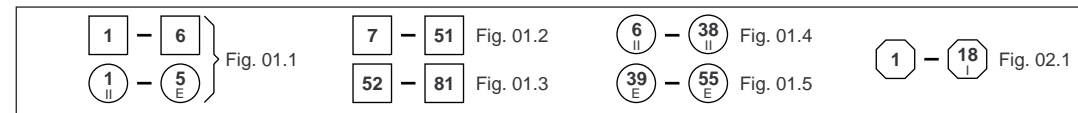

VARIANT: AJ26 SC ROW Vehicles
 VIN RANGE: 024687 →
 DATE OF ISSUE: FEBRUARY 1998



NOTE: Gear Selector Illumination Module – CAN 'Listen only' node for gear selector position indicators.

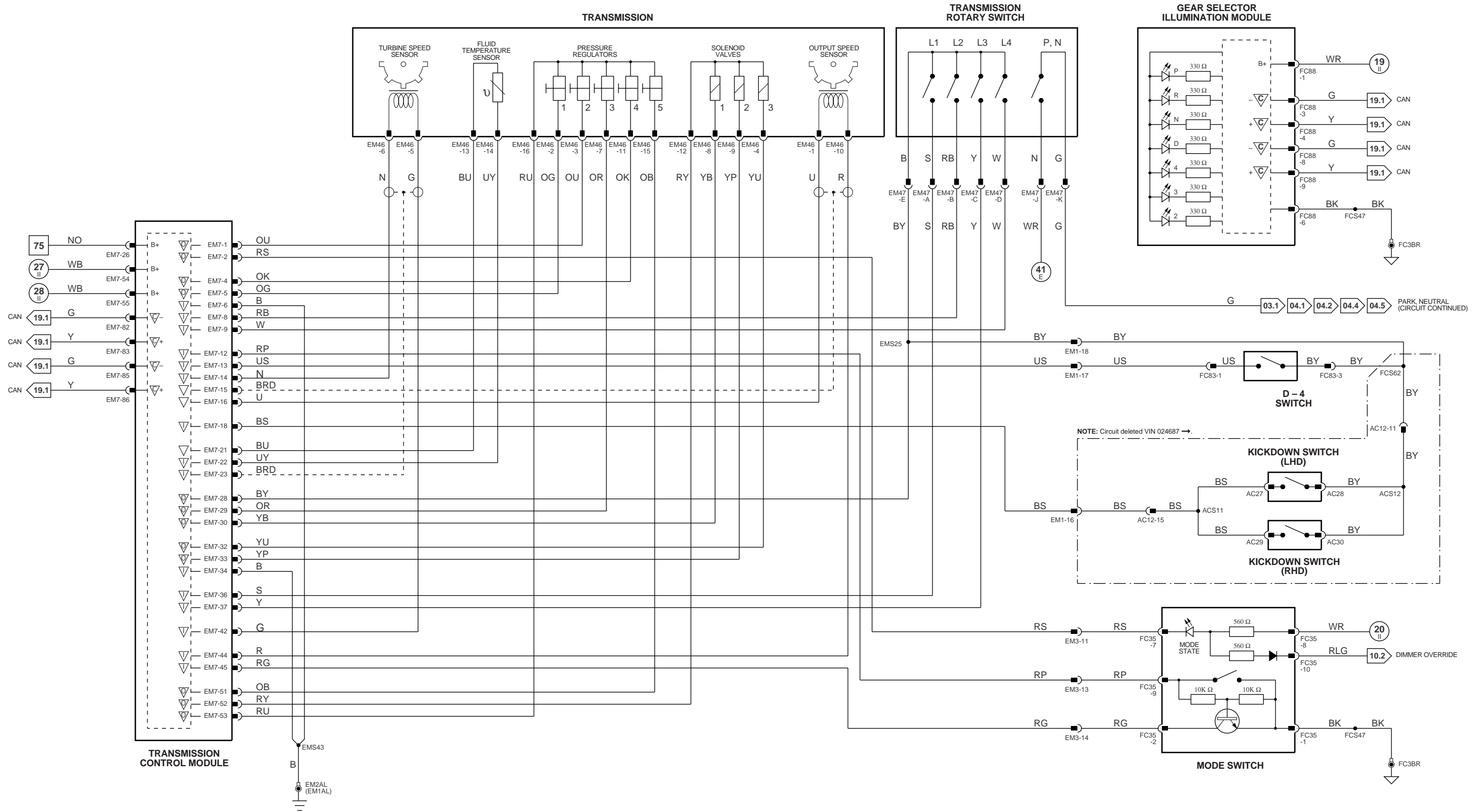

VARIANT: AJ26 N/A Vehicles
 VIN RANGE: 018108 →
 DATE OF ISSUE: FEBRUARY 1998

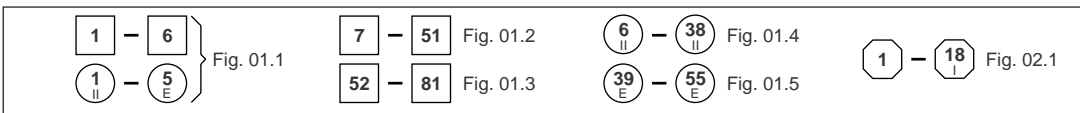
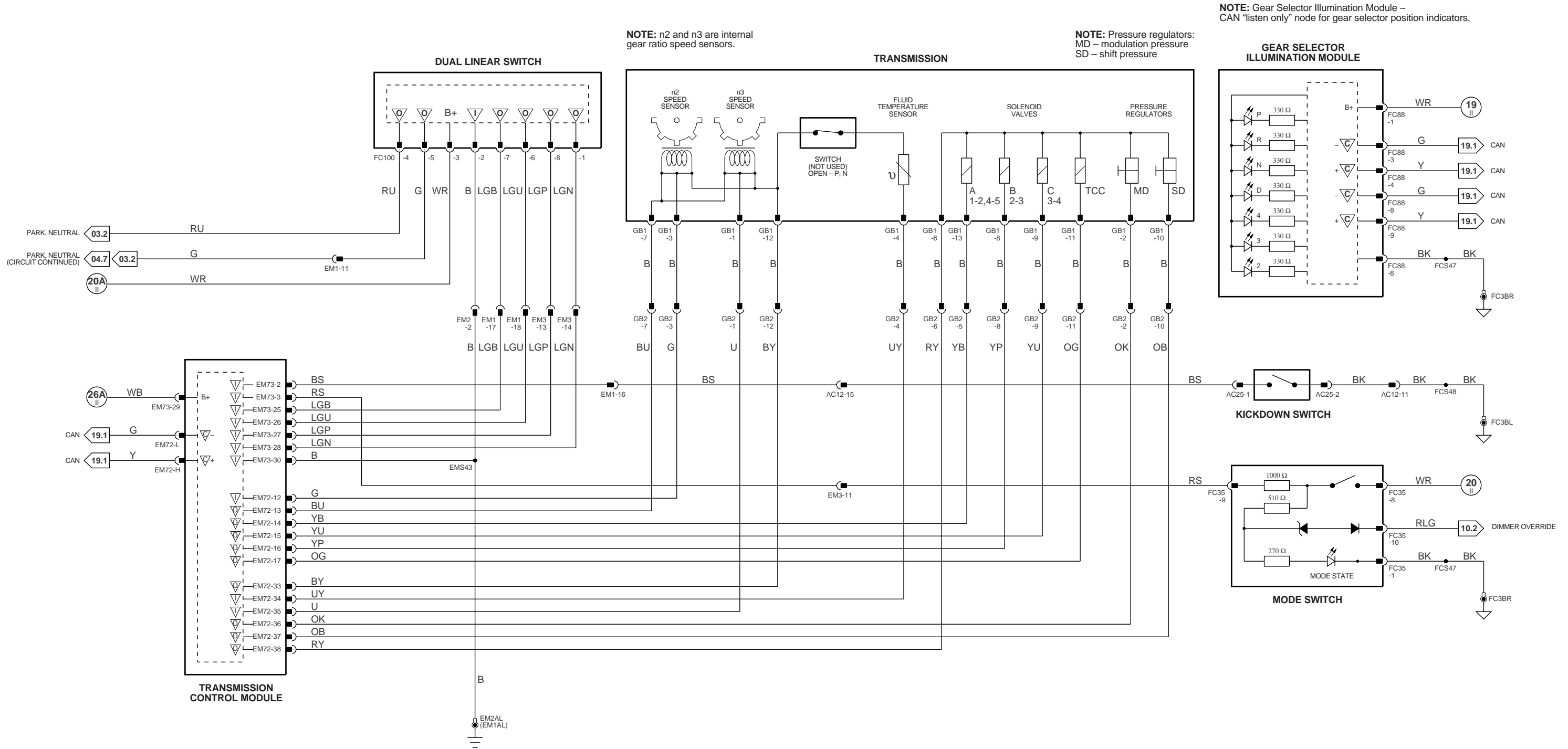

VARIANT: AJ26 SC Vehicles
 VIN RANGE: 024687 →
 DATE OF ISSUE: FEBRUARY 1998

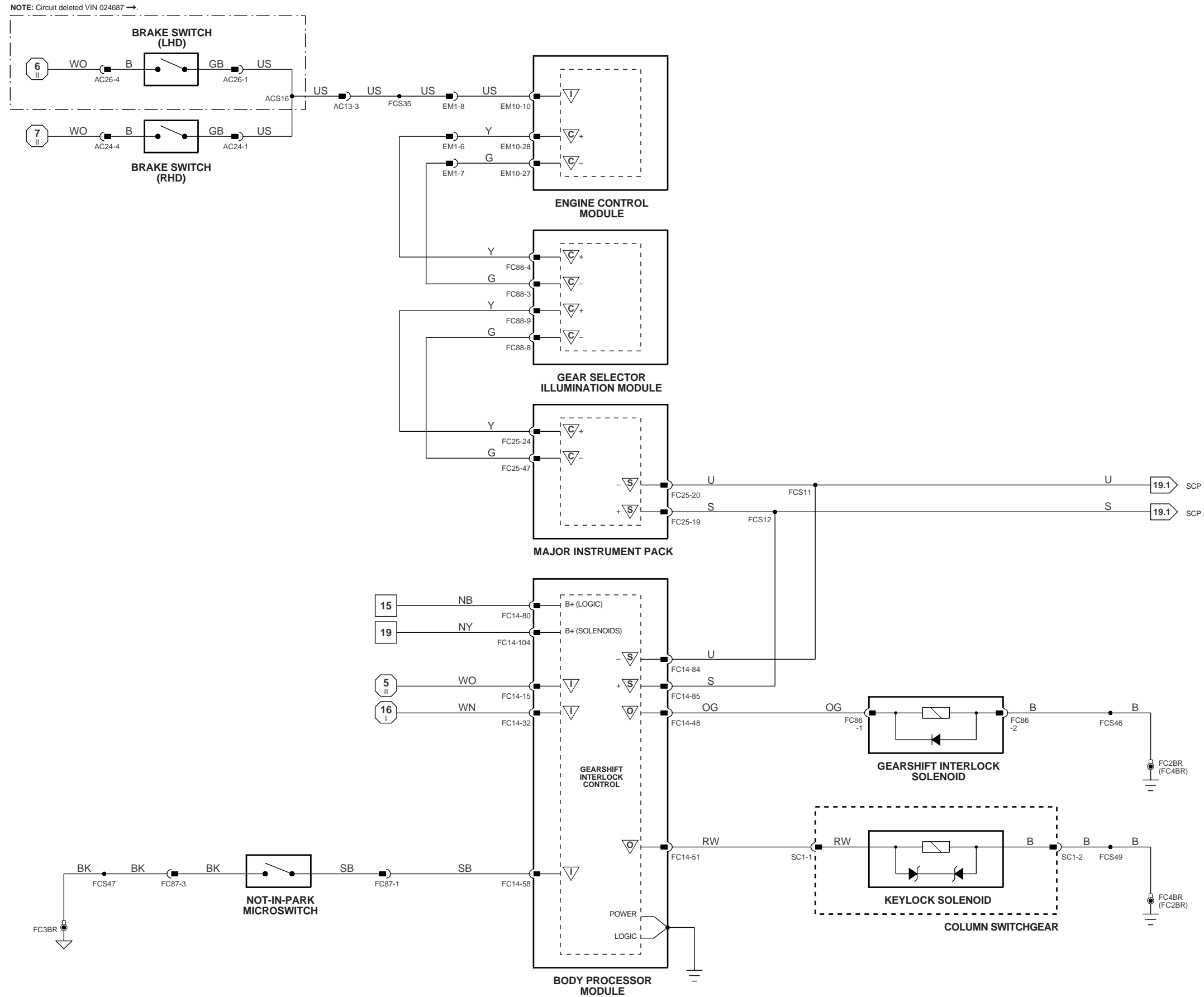

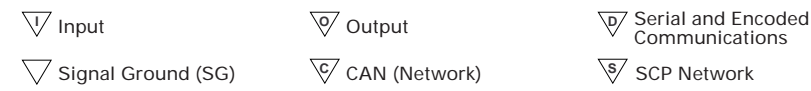
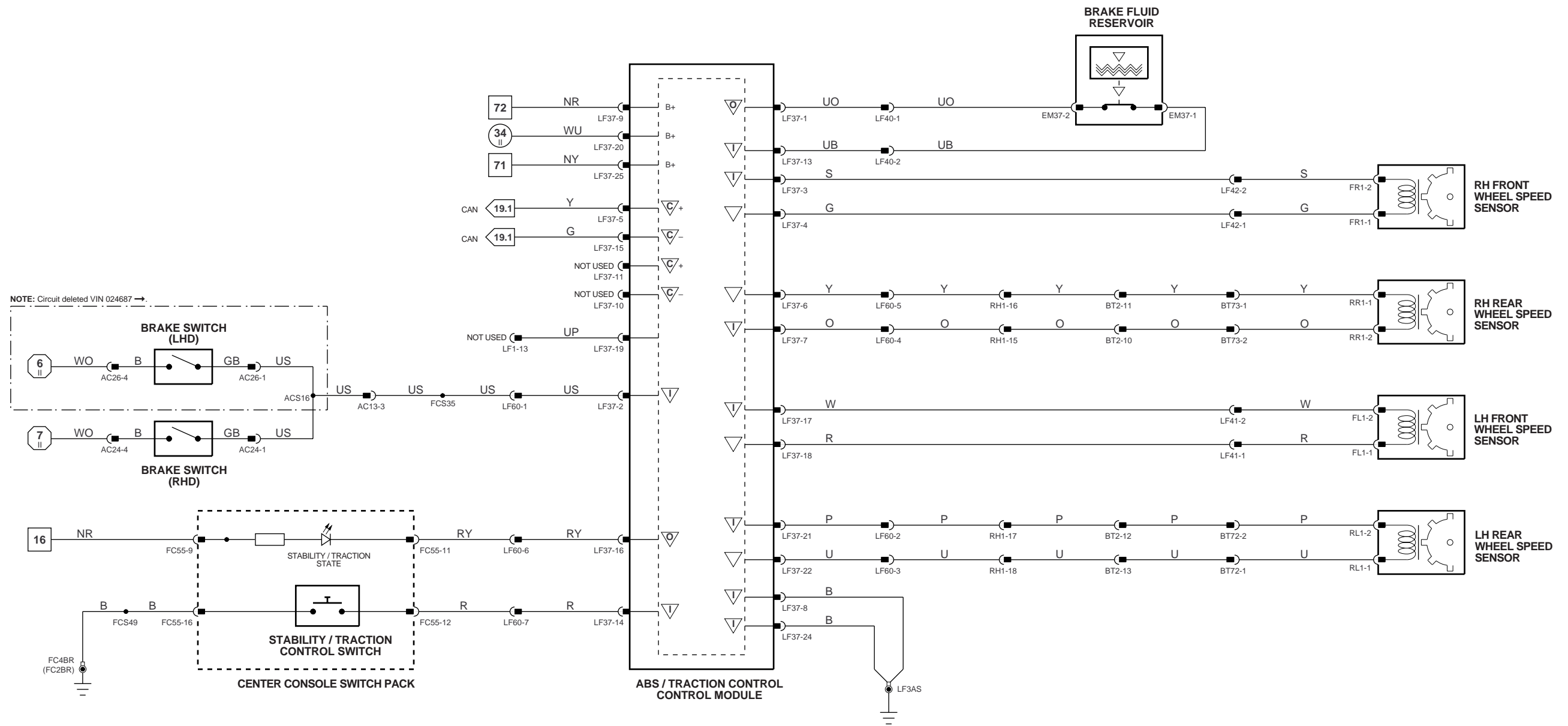

VARIANT: All Vehicles
 VIN RANGE: 018108 →
 DATE OF ISSUE: FEBRUARY 1998



NOTES: When the ignition switched ground input is interrupted during engine cranking, the A/CCM does not drive high power consuming components.
The A/C Isolate Relay remains energized by the A/CCM for 30 seconds after the ignition is switched OFF to provide power for the A/CCM to 'park' the servos.

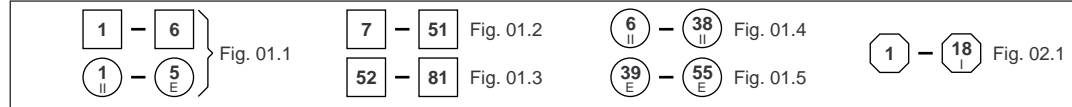
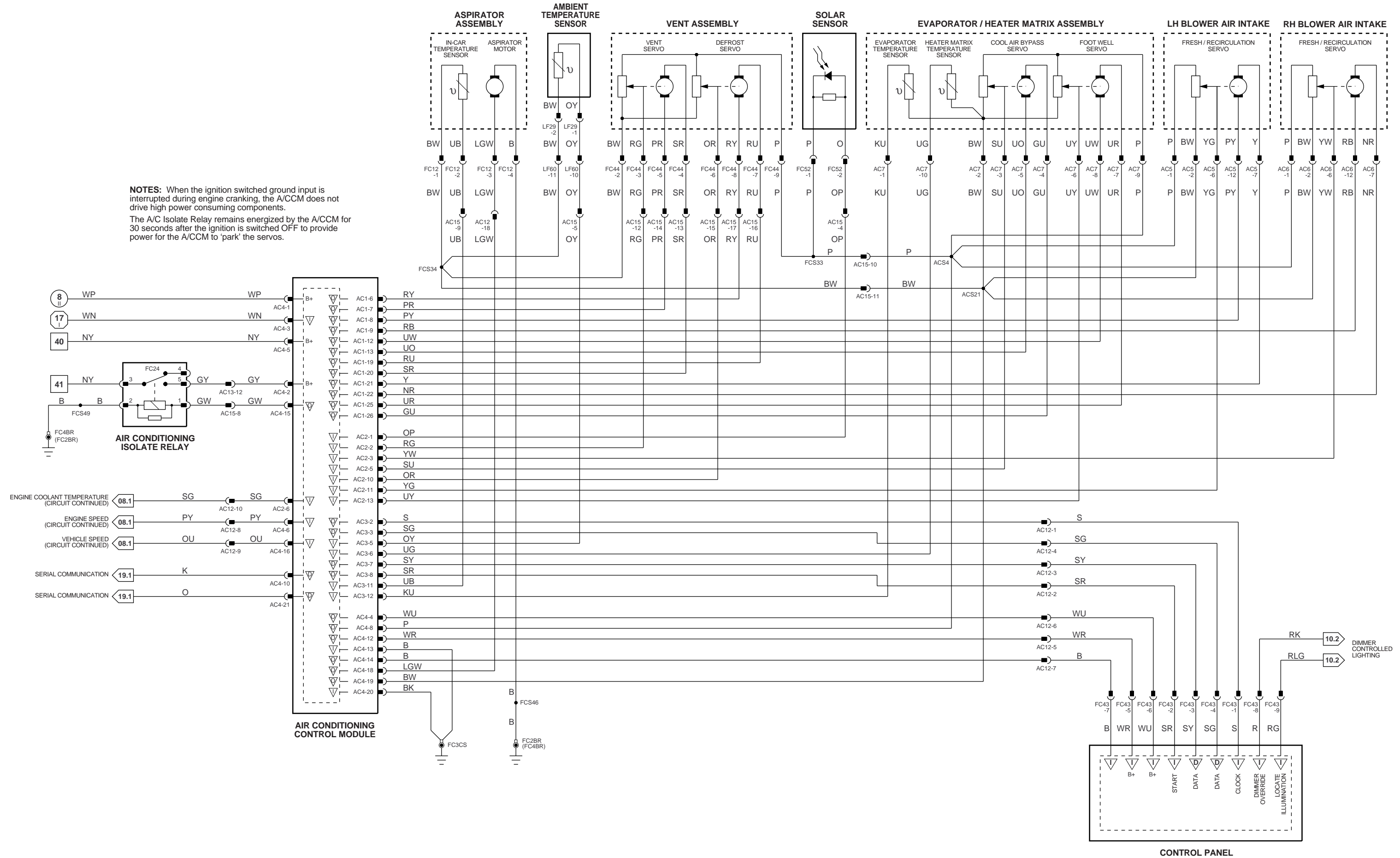

VARIANT: All Vehicles
VIN RANGE: 018108 →
DATE OF ISSUE: SEPTEMBER 1997

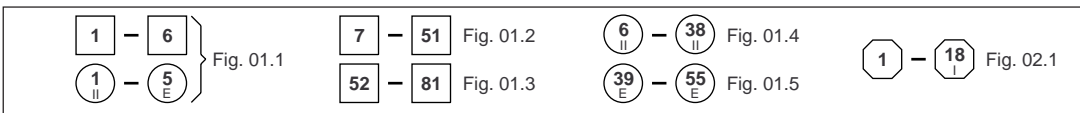
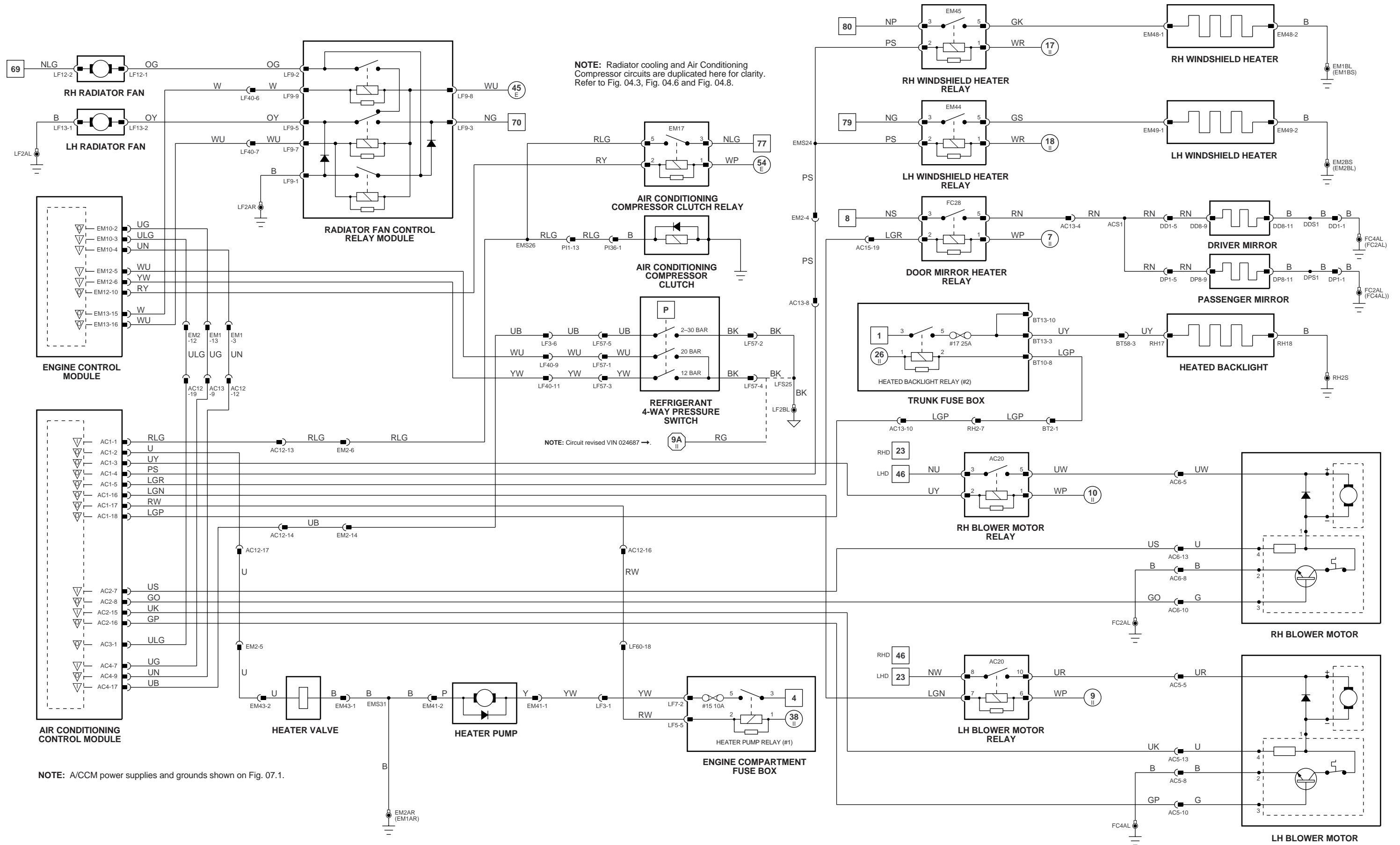

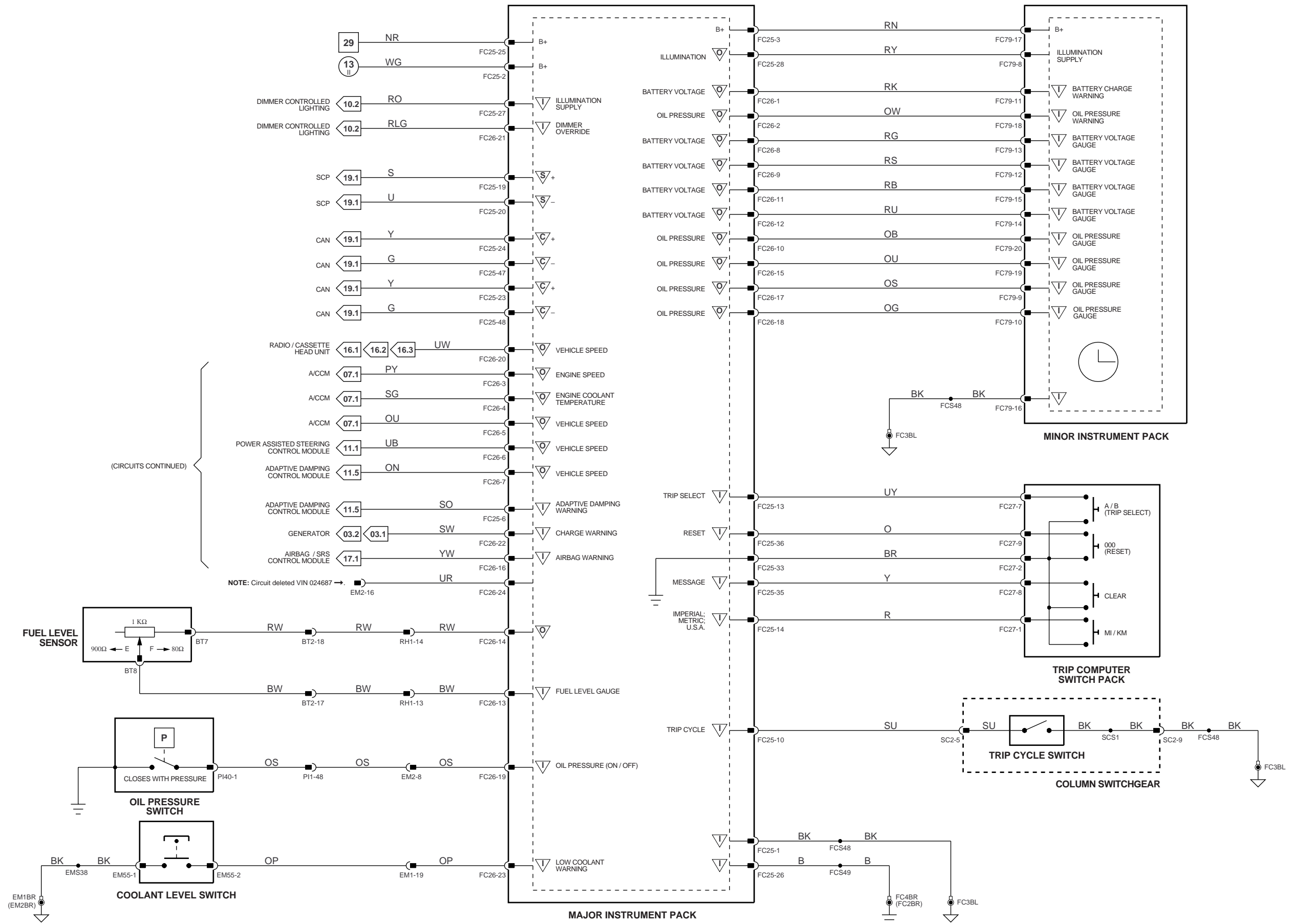



SCP SOURCES:

- DIRECTION INDICATORS; HAZARD WARNING; SIDE LAMPS – Fig. 09.1, Fig. 09.2
- VALET SWITCH; TRUNK RELEASE – Fig. 13.1
- MEMORY – Fig. 12.1
- CONVERTIBLE TOP MOVEMENT – Fig. 15.2
- KEY-IN-IGNITION SWITCH / DRIVER DOOR SWITCH – Fig. 13.1
- NOT-IN-PARK MICROSWITCH – Fig. 05.3
- SEAT BELT SWITCH – Fig. 12.1

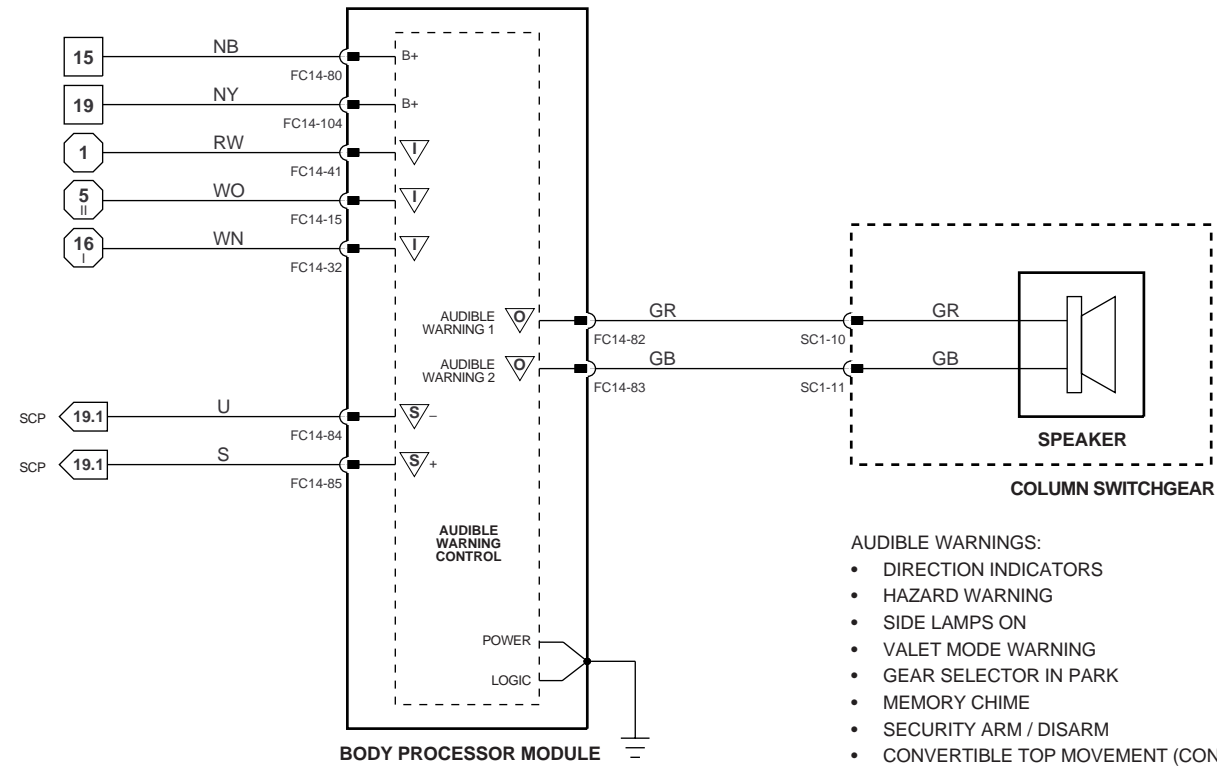

- AUDIBLE WARNINGS:
- DIRECTION INDICATORS
 - HAZARD WARNING
 - SIDE LAMPS ON
 - VALET MODE WARNING
 - GEAR SELECTOR IN PARK
 - MEMORY CHIME
 - SECURITY ARM / DISARM
 - CONVERTIBLE TOP MOVEMENT (CONVERTIBLE VEHICLES)
 - KEY-IN-IGNITION SWITCH / DRIVER DOOR AJAR (NAS VEHICLES ONLY)
 - SEAT BELT DISCONNECTED (NAS VEHICLES ONLY)

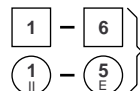

Fig. 01.1

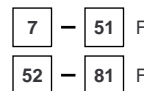

Fig. 01.2

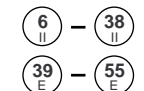

Fig. 01.4

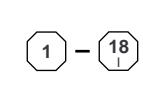

Fig. 02.1

▽ Input

▽ Signal Ground (SG)

▽ Output

▽ CAN (Network)

▽ Serial and Encoded Communications

▽ SCP Network

VARIANT: All Vehicles
 VIN RANGE: 018108 →
 DATE OF ISSUE: FEBRUARY 1998



NOTE: 'Crank' input used with Daytime Running Lamps.

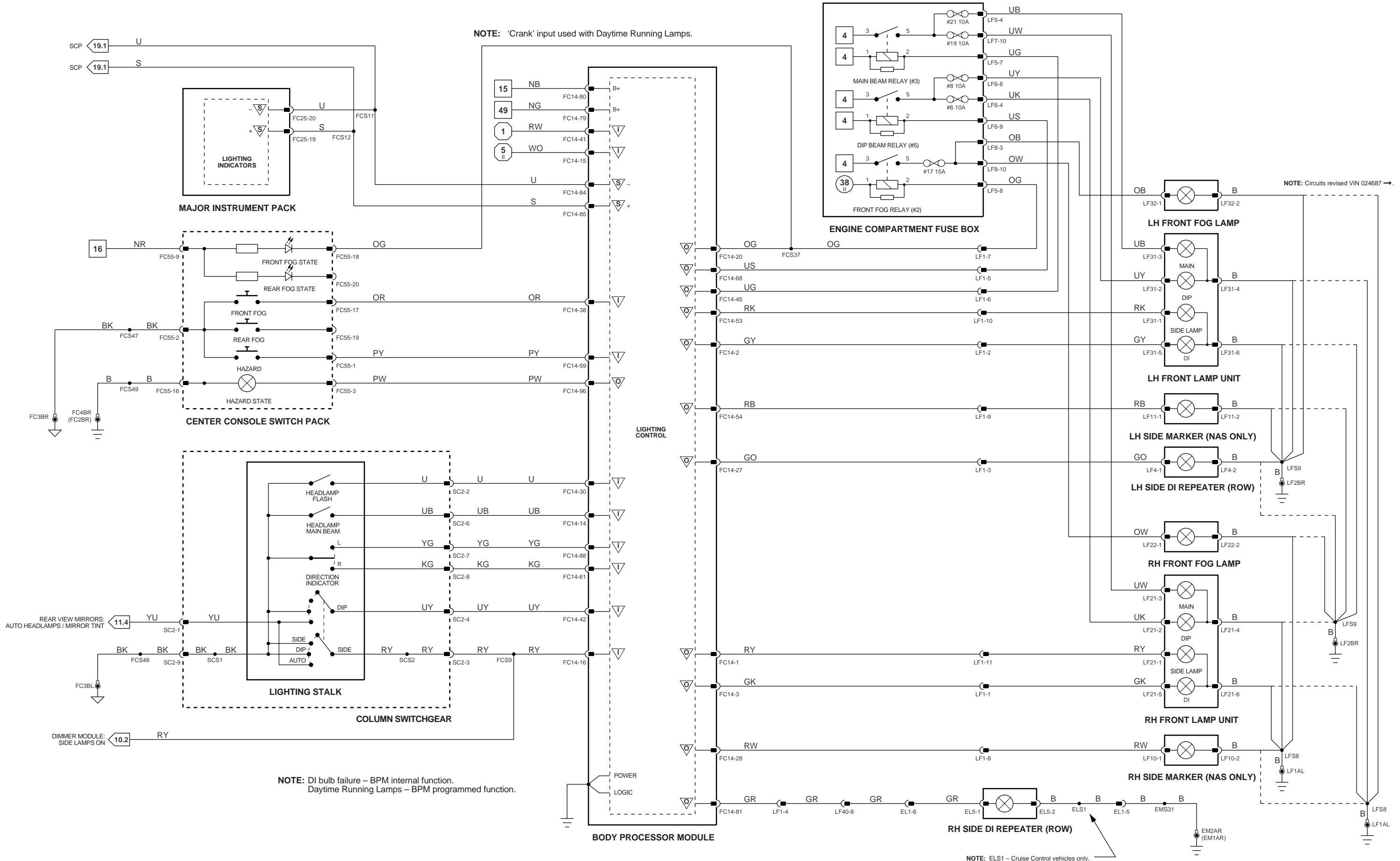

NOTE: DI bulb failure - BPM internal function. Daytime Running Lamps - BPM programmed function.

NOTE: ELS1 - Cruise Control vehicles only.

Fig. 01.1	Fig. 01.2	Fig. 01.4	Fig. 02.1
	Fig. 01.3	Fig. 01.5	

	Input		Output
	Signal Ground (SG)		CAN (Network)
	SCP Network		Serial and Encoded Communications

VARIANT: All Vehicles
 VIN RANGE: 018108 →
 DATE OF ISSUE: FEBRUARY 1998

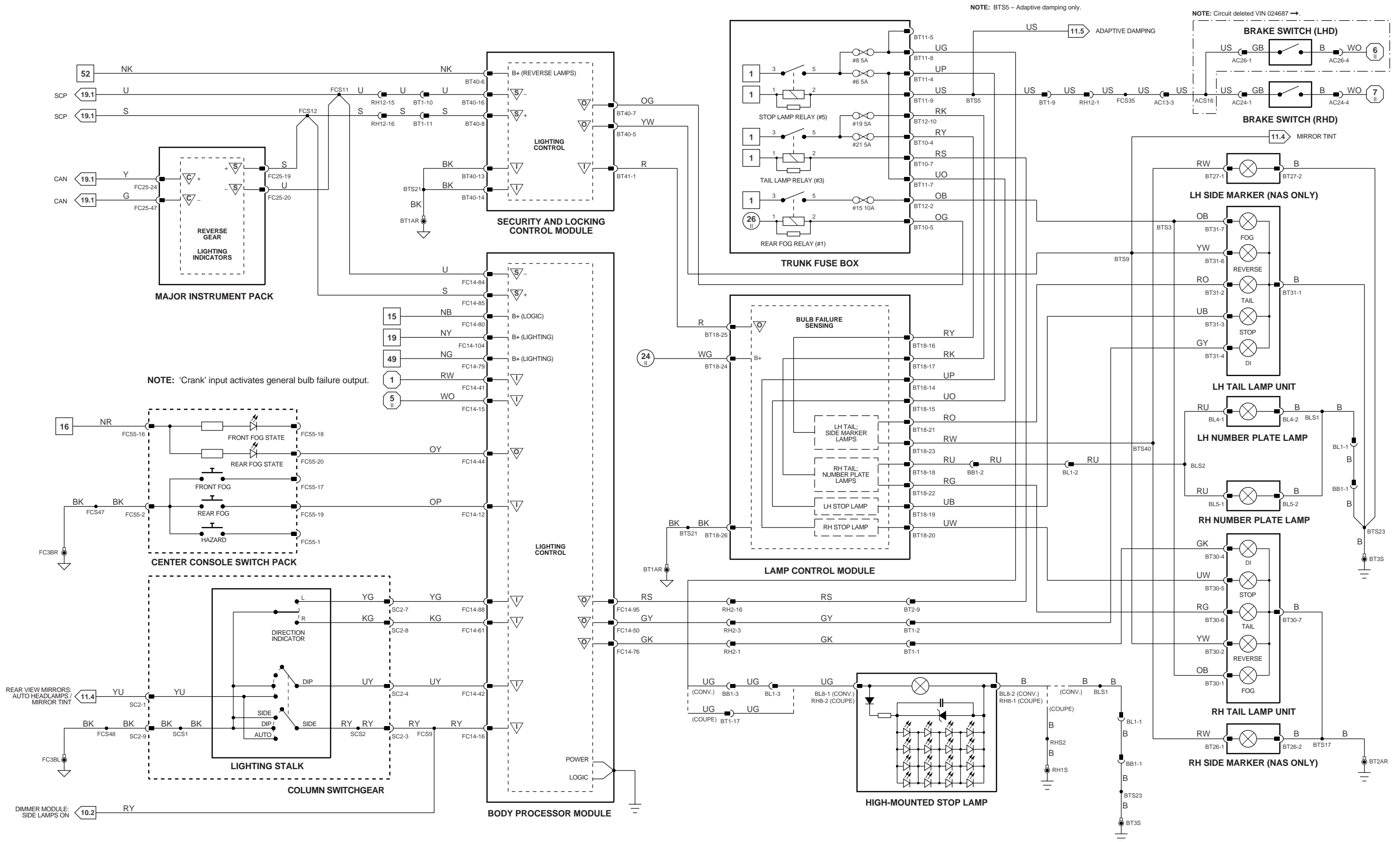

VARIANT: All Vehicles
 VIN RANGE: 018108 →
 DATE OF ISSUE: FEBRUARY 1998

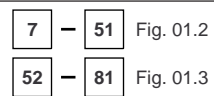
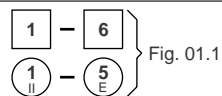
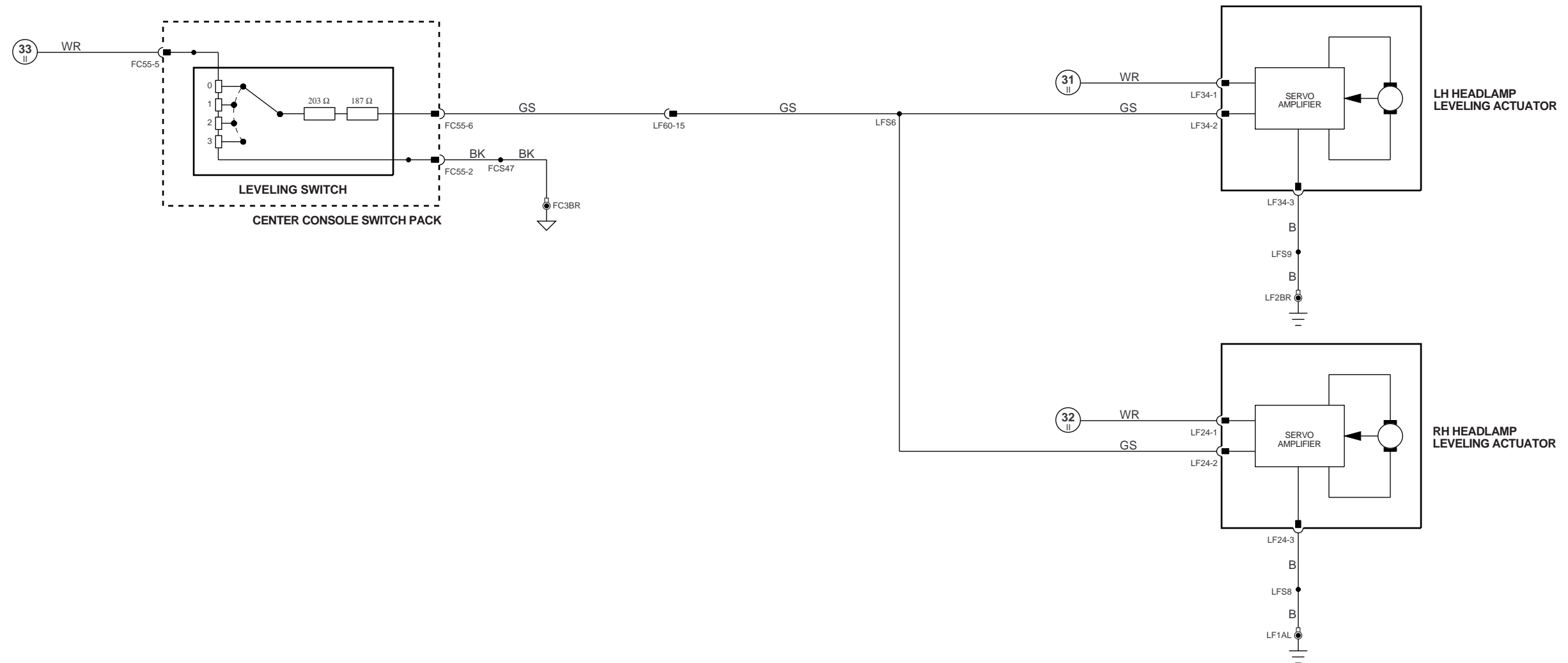

▽ Input

▽ Signal Ground (SG)

▽ Output

▽ CAN (Network)

▽ Serial and Encoded Communications

▽ SCP Network

VARIANT: Headlamp Leveling Vehicles
 VIN RANGE: 018108 →
 DATE OF ISSUE: SEPTEMBER 1997



NOTE: 'Crank' input is used to switch off interior lamps during engine cranking.

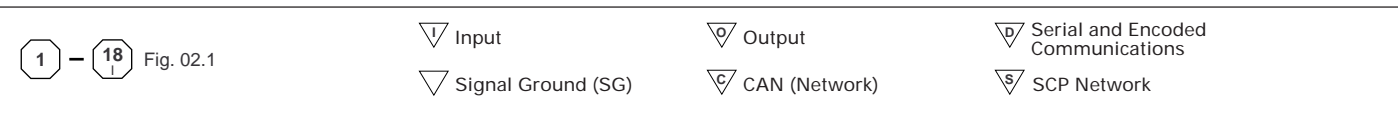
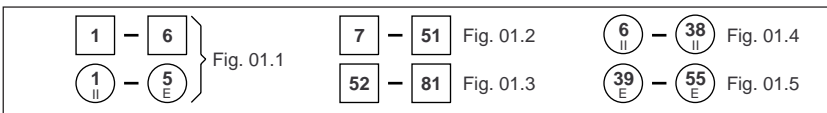
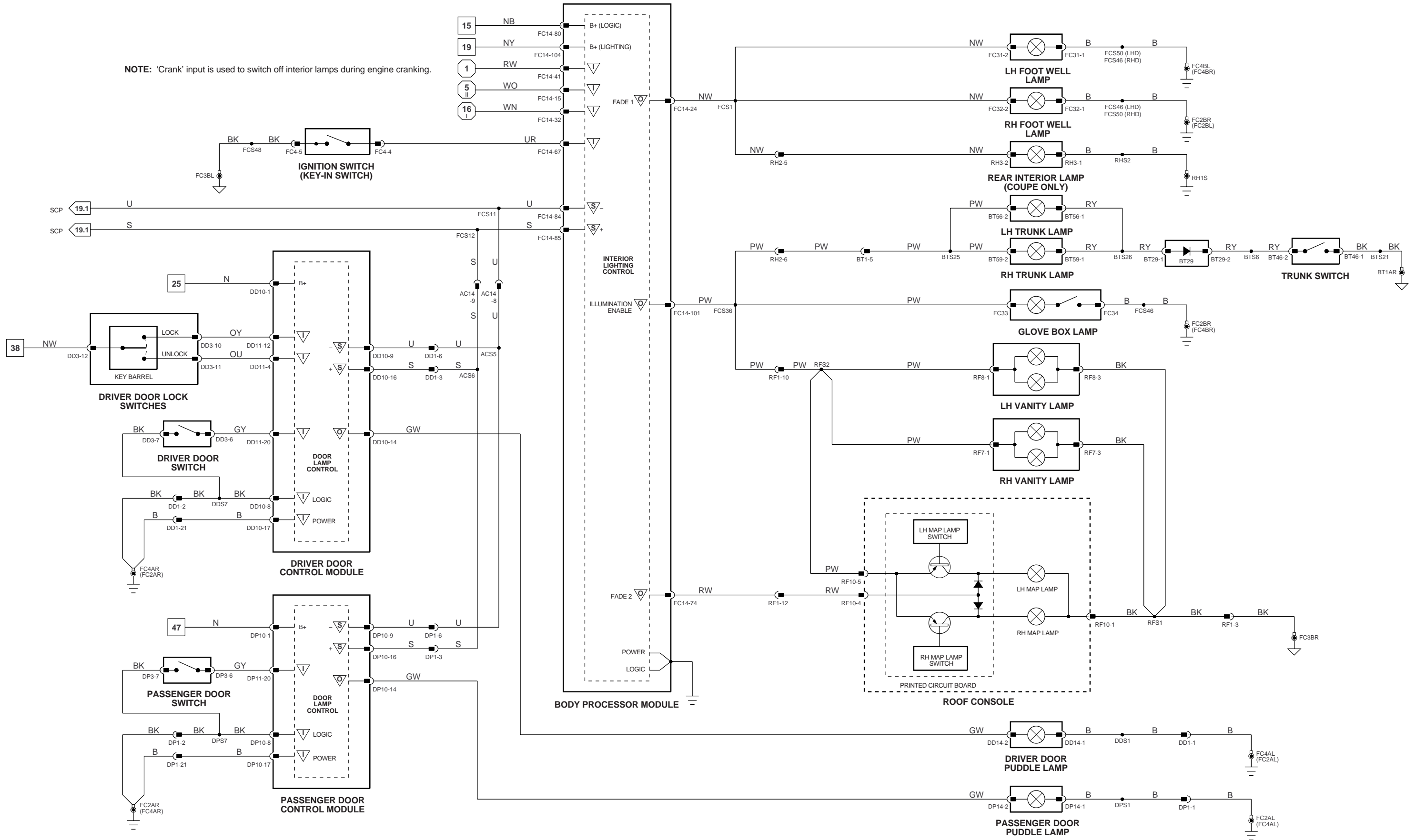

VARIANT: All Vehicles
 VIN RANGE: 018108 →
 DATE OF ISSUE: SEPTEMBER 1997

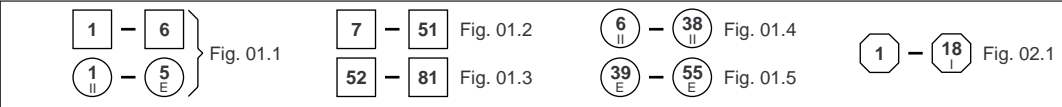
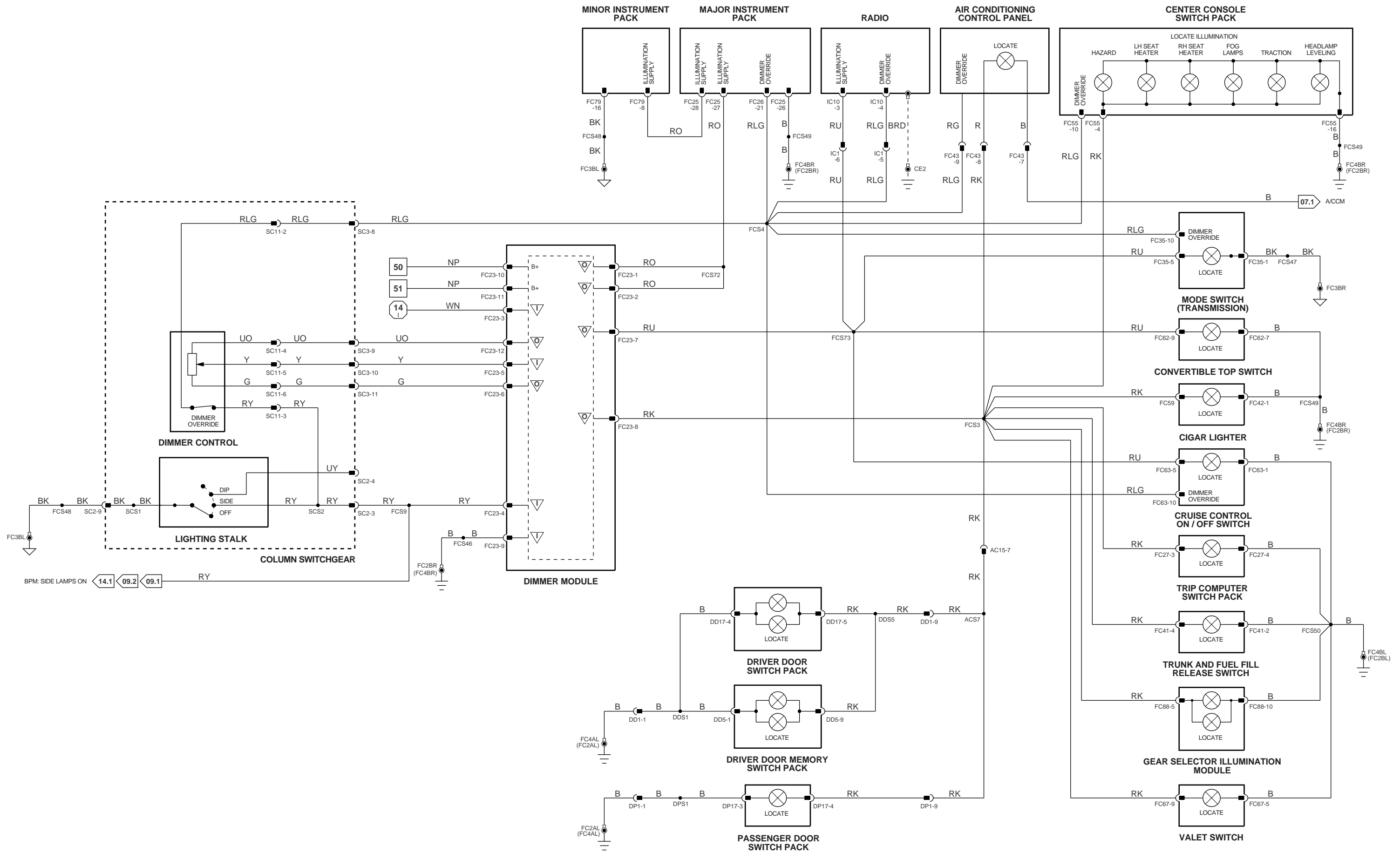

VARIANT: All Vehicles
 VIN RANGE: 018108 →
 DATE OF ISSUE: SEPTEMBER 1997

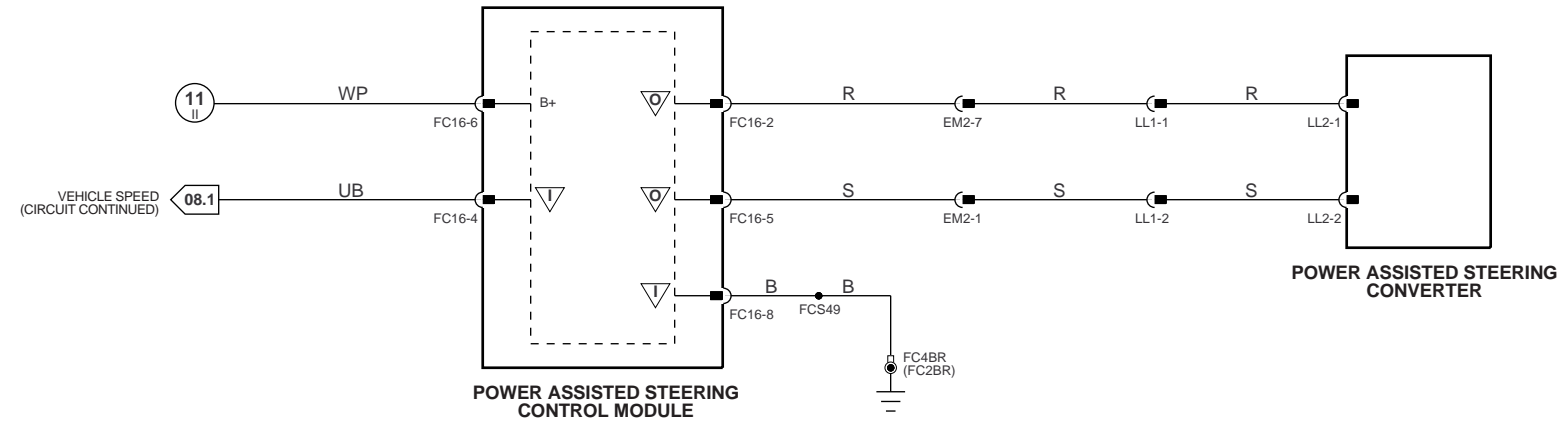

LHD

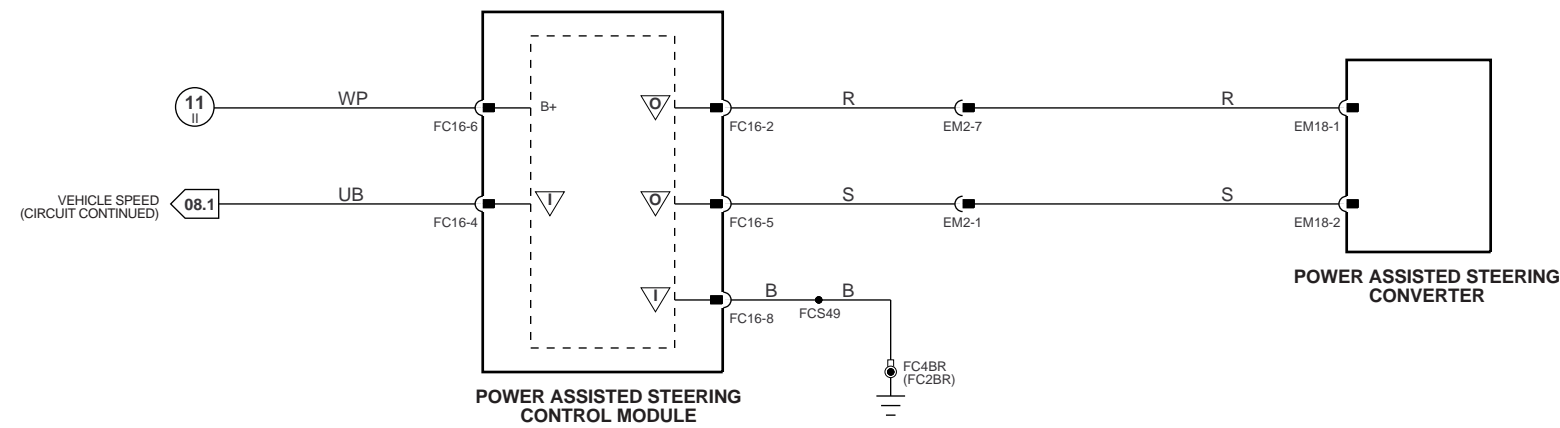

RHD

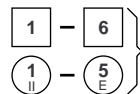

Fig. 01.1



Fig. 01.2

Fig. 01.3



Fig. 01.4

Fig. 01.5



Fig. 02.1

▽ Input

▽ Signal Ground (SG)

▽ Output

▽ CAN (Network)

▽ Serial and Encoded Communications

▽ SCP Network

VARIANT: All Vehicles
 VIN RANGE: 018108 →
 DATE OF ISSUE: SEPTEMBER 1997

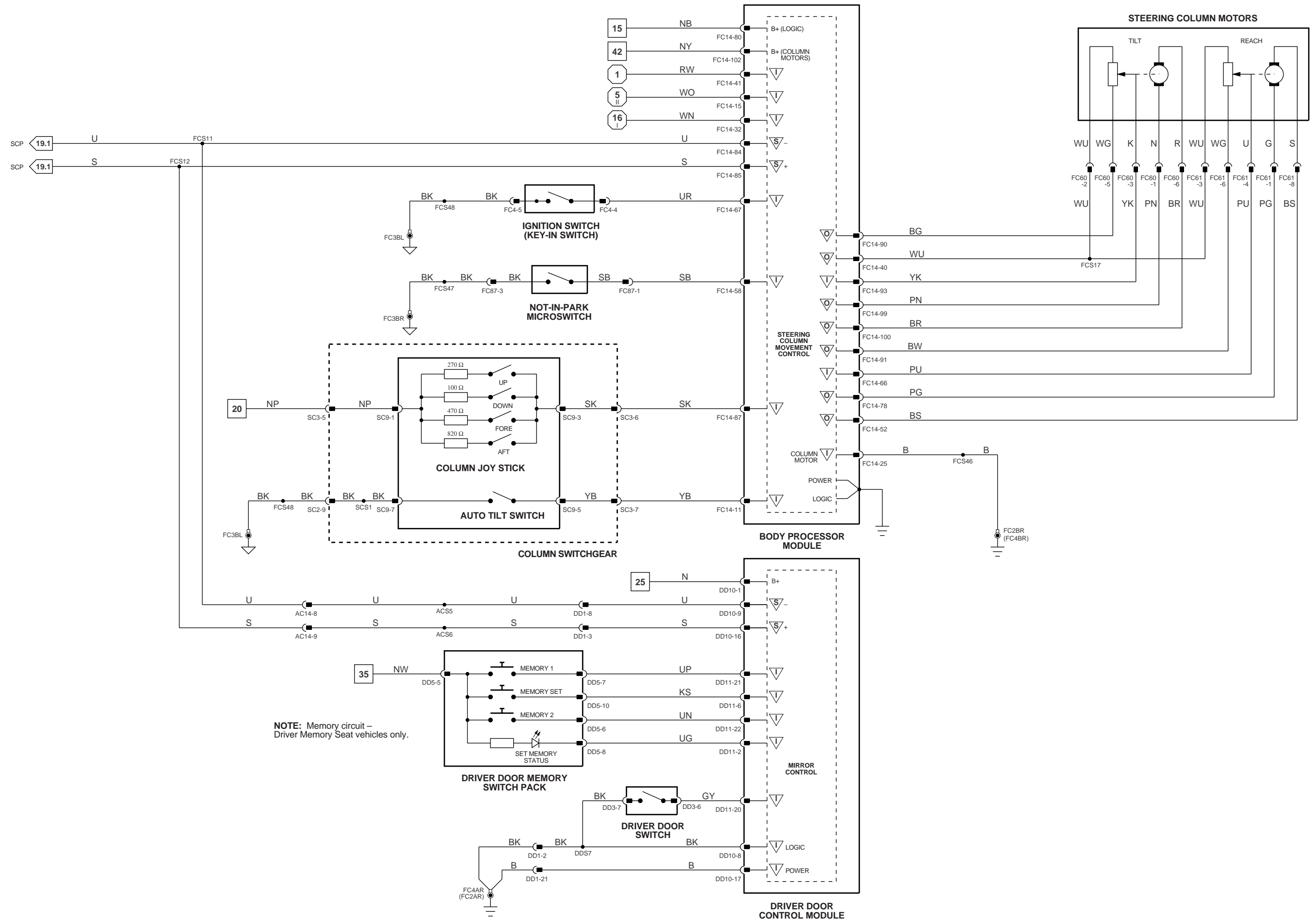

NOTE: Memory circuit – Driver Memory Seat vehicles only.

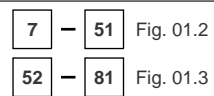
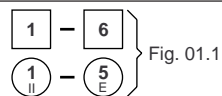

▽ Input

▽ Output

▽ Signal Ground (SG)

▽ CAN (Network)

▽ Serial and Encoded Communications

▽ SCP Network

VARIANT: All Vehicles
 VIN RANGE: 018108 →
 DATE OF ISSUE: SEPTEMBER 1997

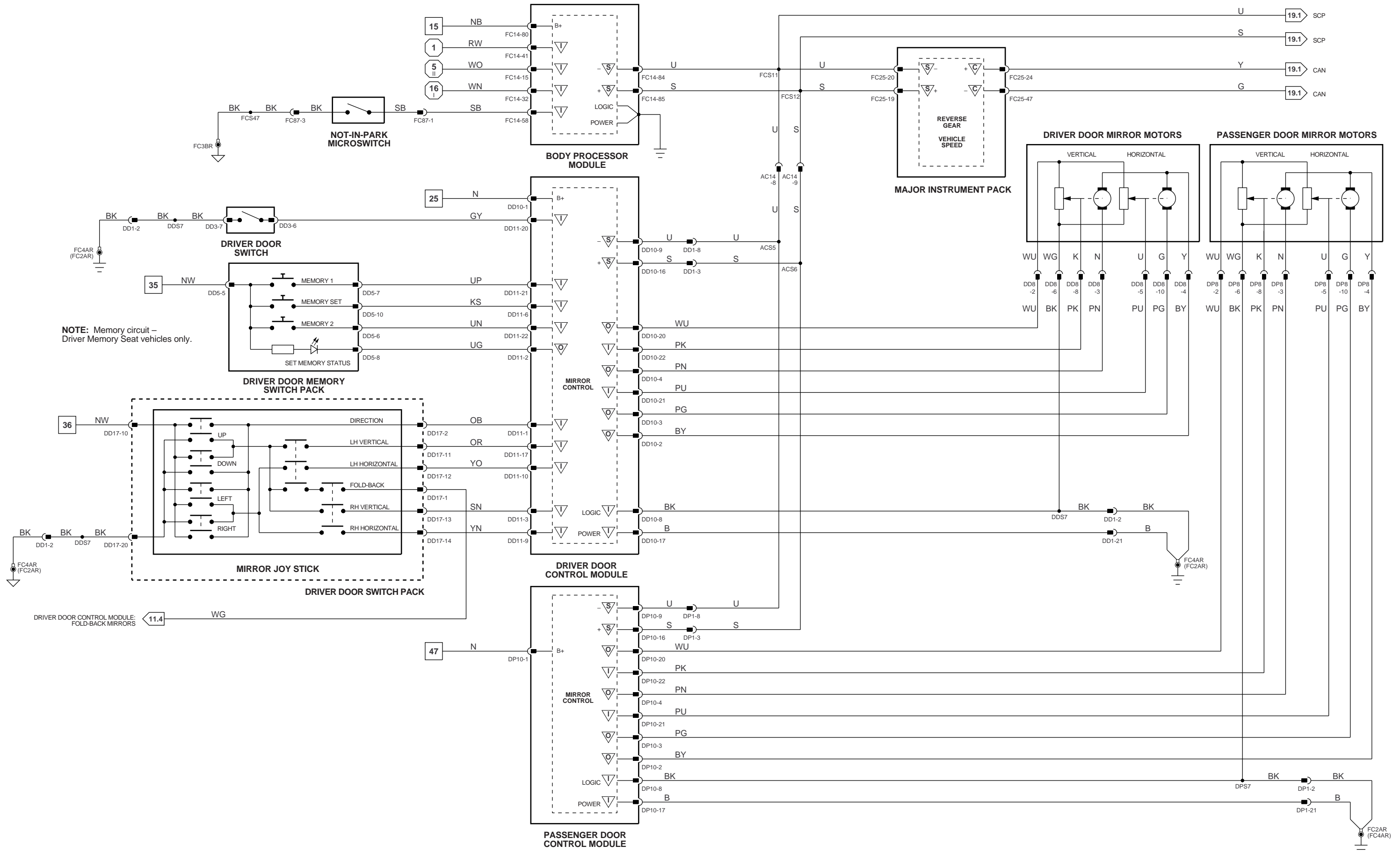

NOTE: Memory circuit – Driver Memory Seat vehicles only.

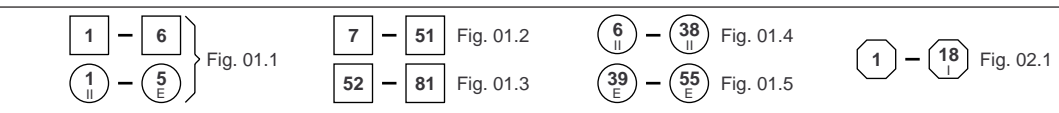

VARIANT: All Vehicles
 VIN RANGE: 018108 →
 DATE OF ISSUE: SEPTEMBER 1997

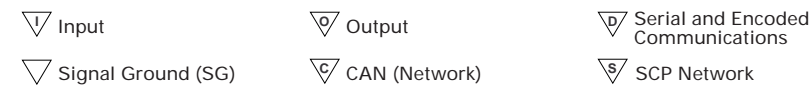
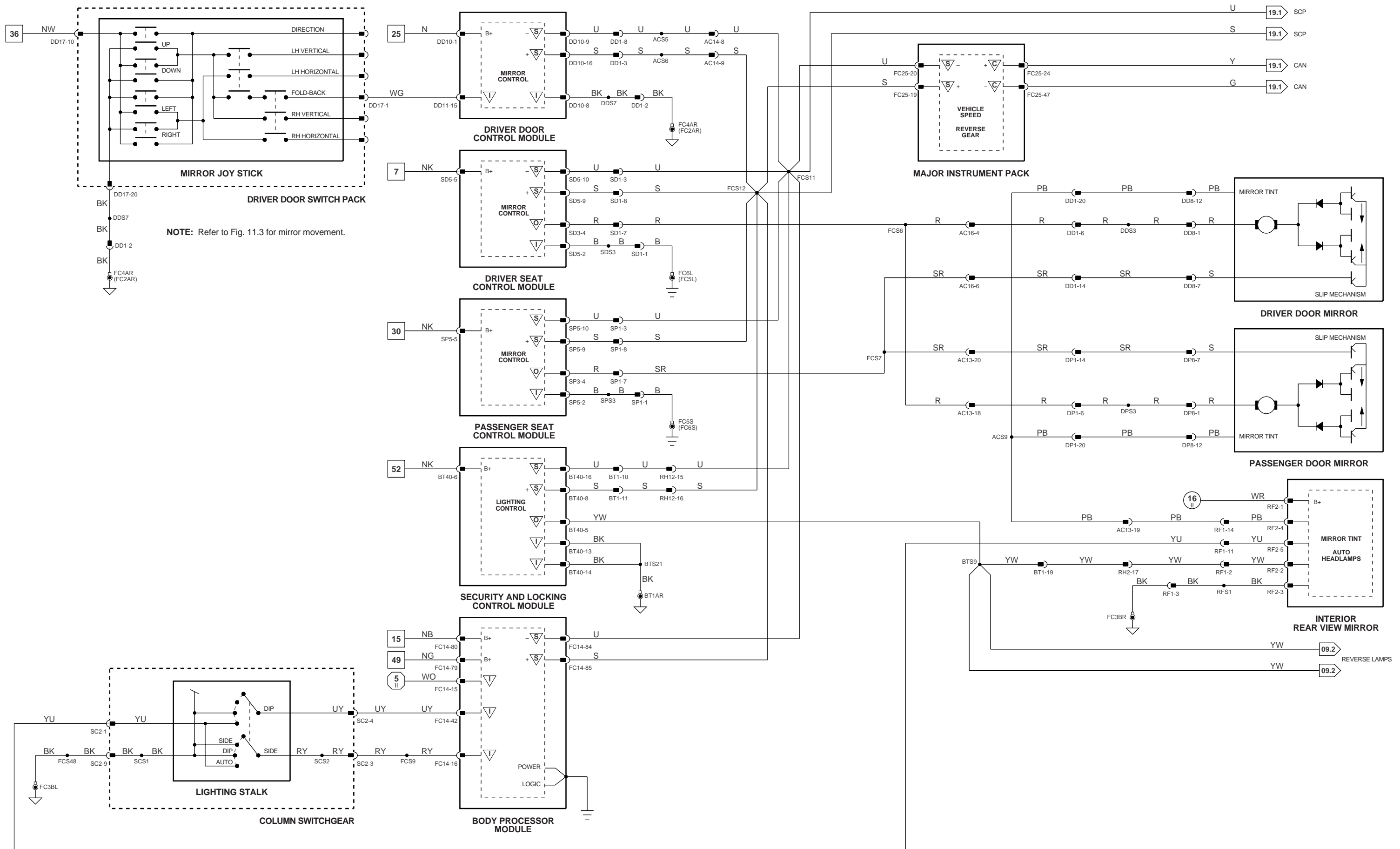

VARIANT: All Vehicles
 VIN RANGE: 018108 →
 DATE OF ISSUE: SEPTEMBER 1997

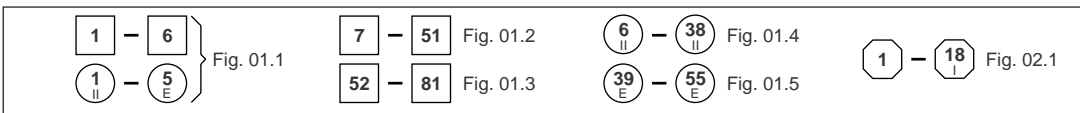
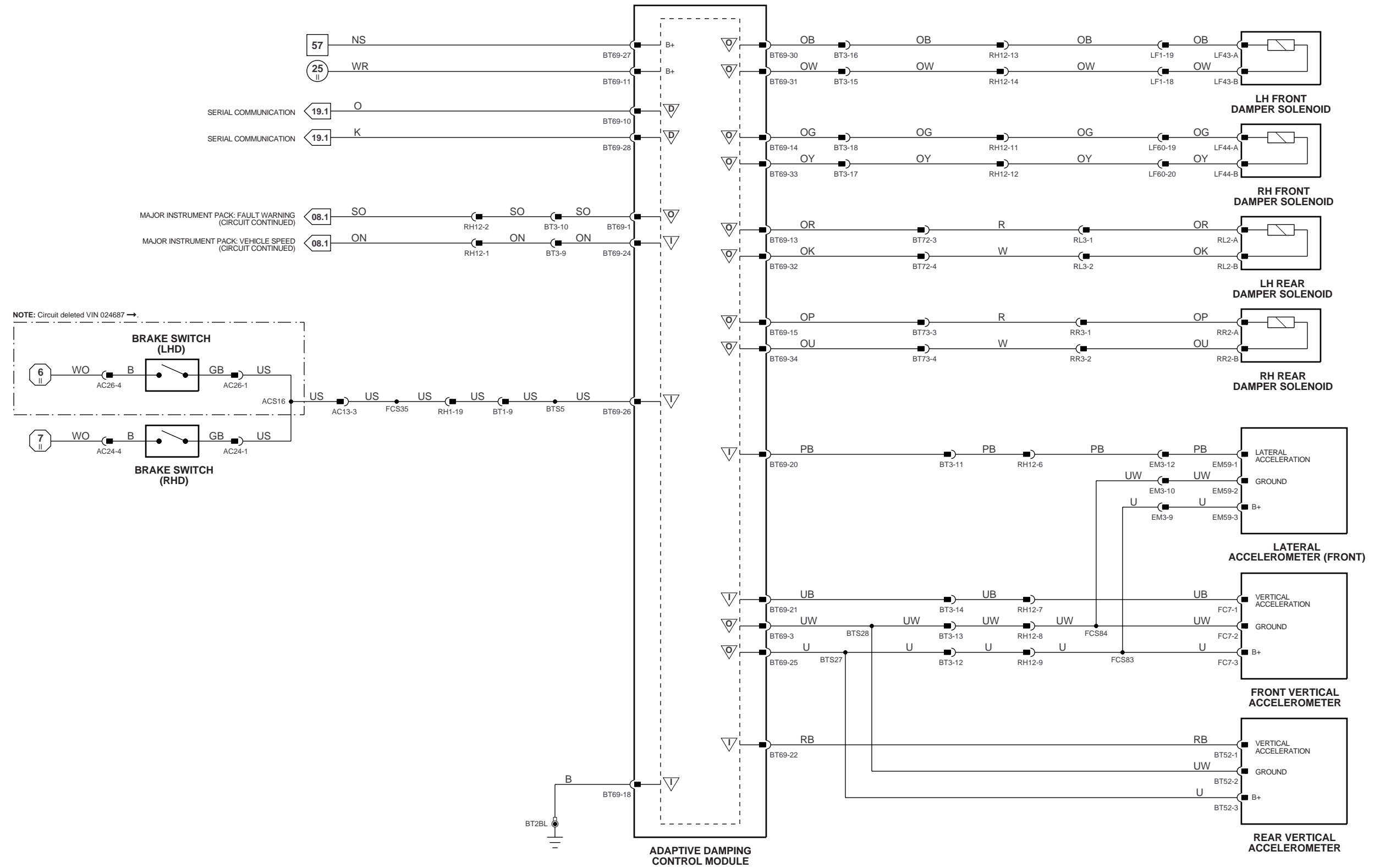

VARIANT: Adaptive Damping Vehicles
 VIN RANGE: 018108 →
 DATE OF ISSUE: FEBRUARY 1998

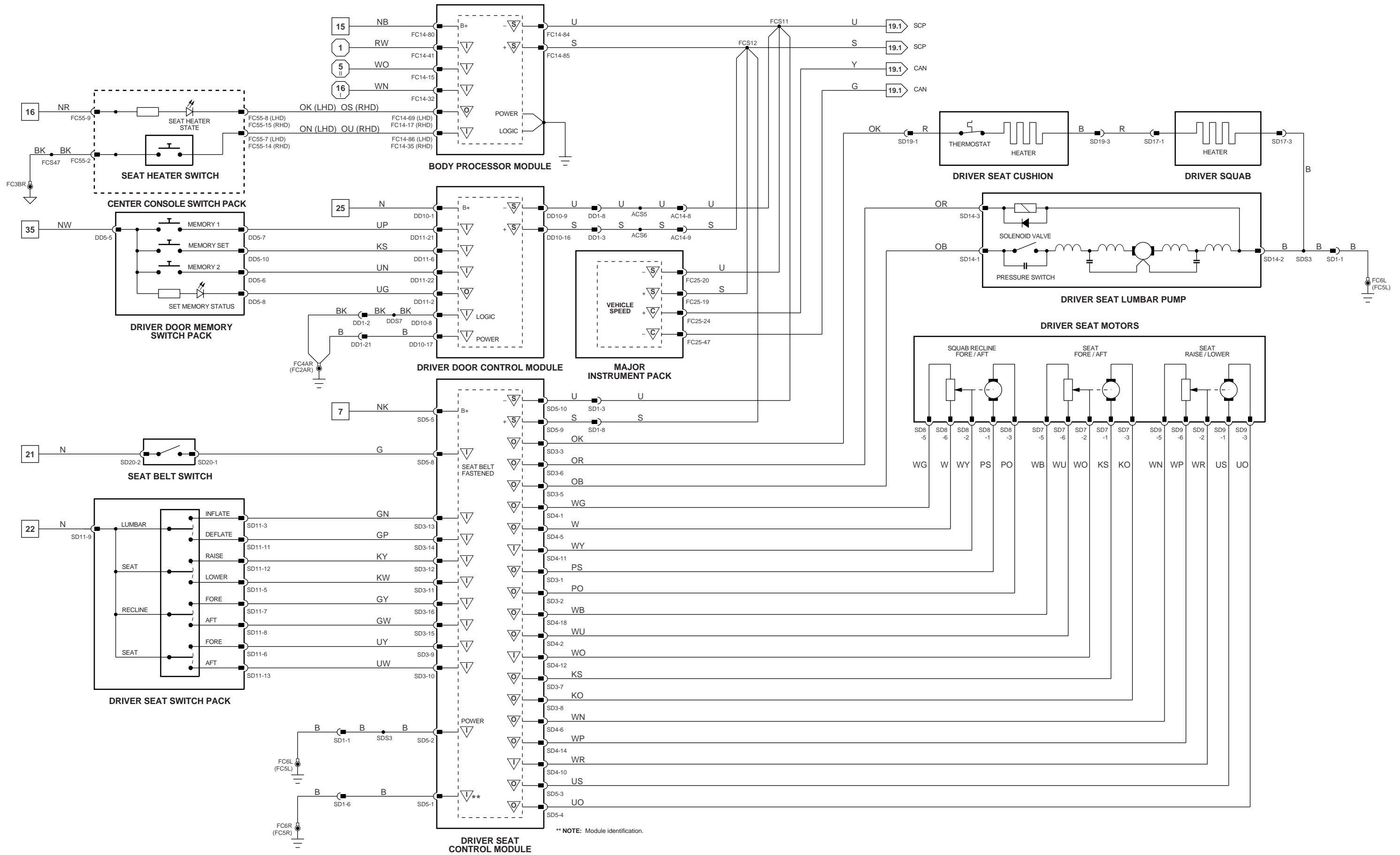

** NOTE: Module identification.

Fig. 01.1 Fig. 01.1	Fig. 01.2 Fig. 01.3	Fig. 01.4 Fig. 01.5	Fig. 02.1	Input Signal Ground (SG)	Output CAN (Network)	Serial and Encoded Communications SCP Network	VARIANT: Memory Seat Vehicles VIN RANGE: 018108 → DATE OF ISSUE: SEPTEMBER 1997
------------------------	------------------------	------------------------	-----------	-----------------------------	-------------------------	--	--

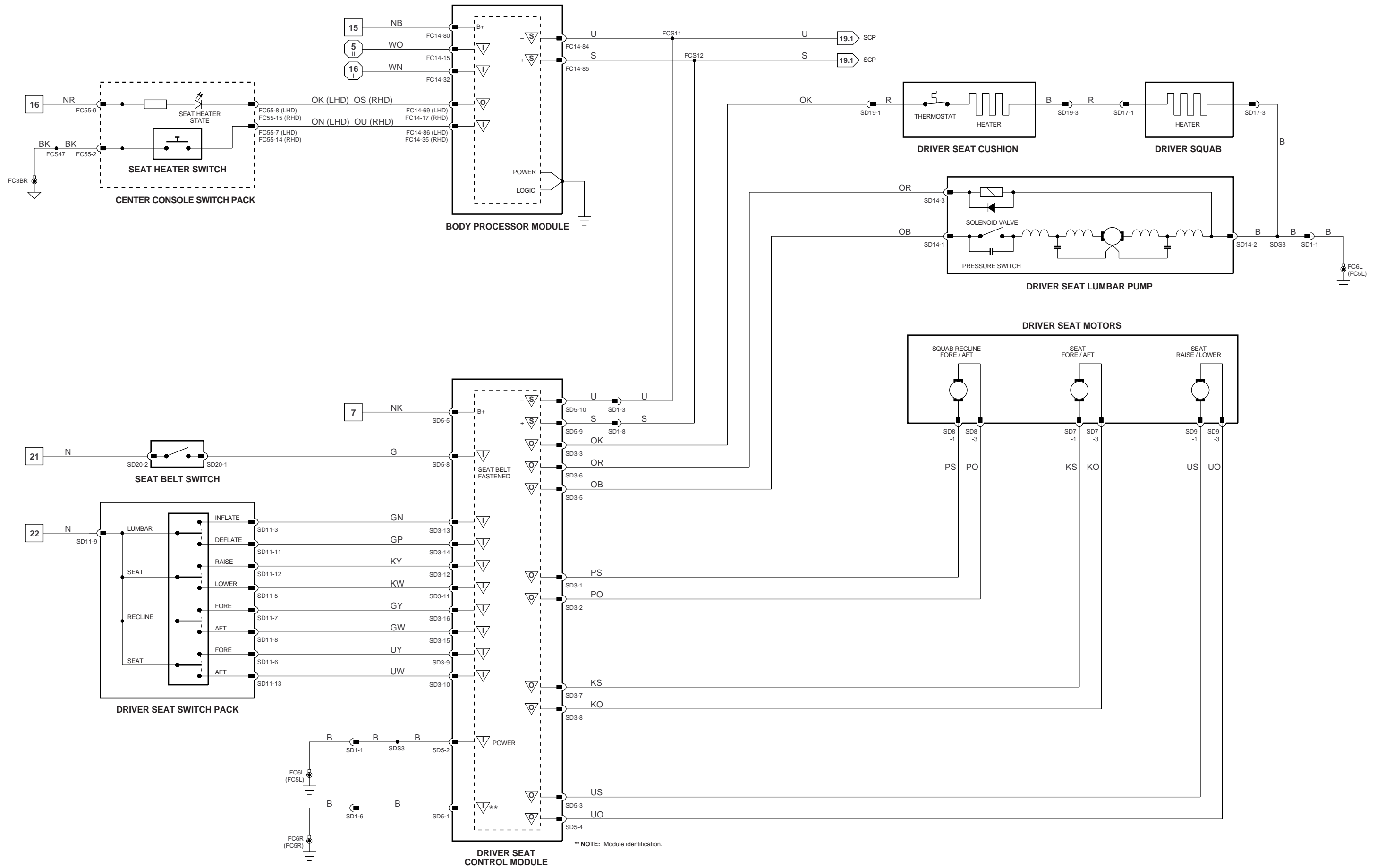

** NOTE: Module identification.

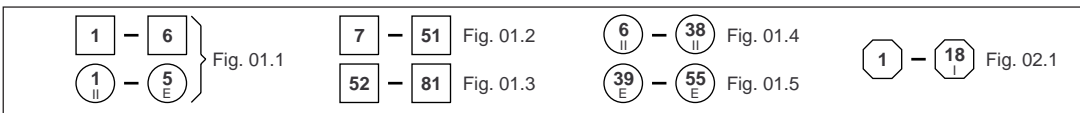

VARIANT: Non Memory Seat Vehicles
 VIN RANGE: 018108 →
 DATE OF ISSUE: SEPTEMBER 1997

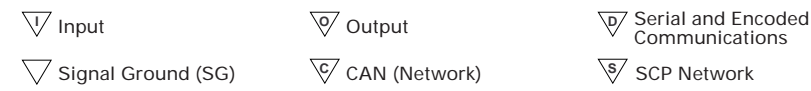
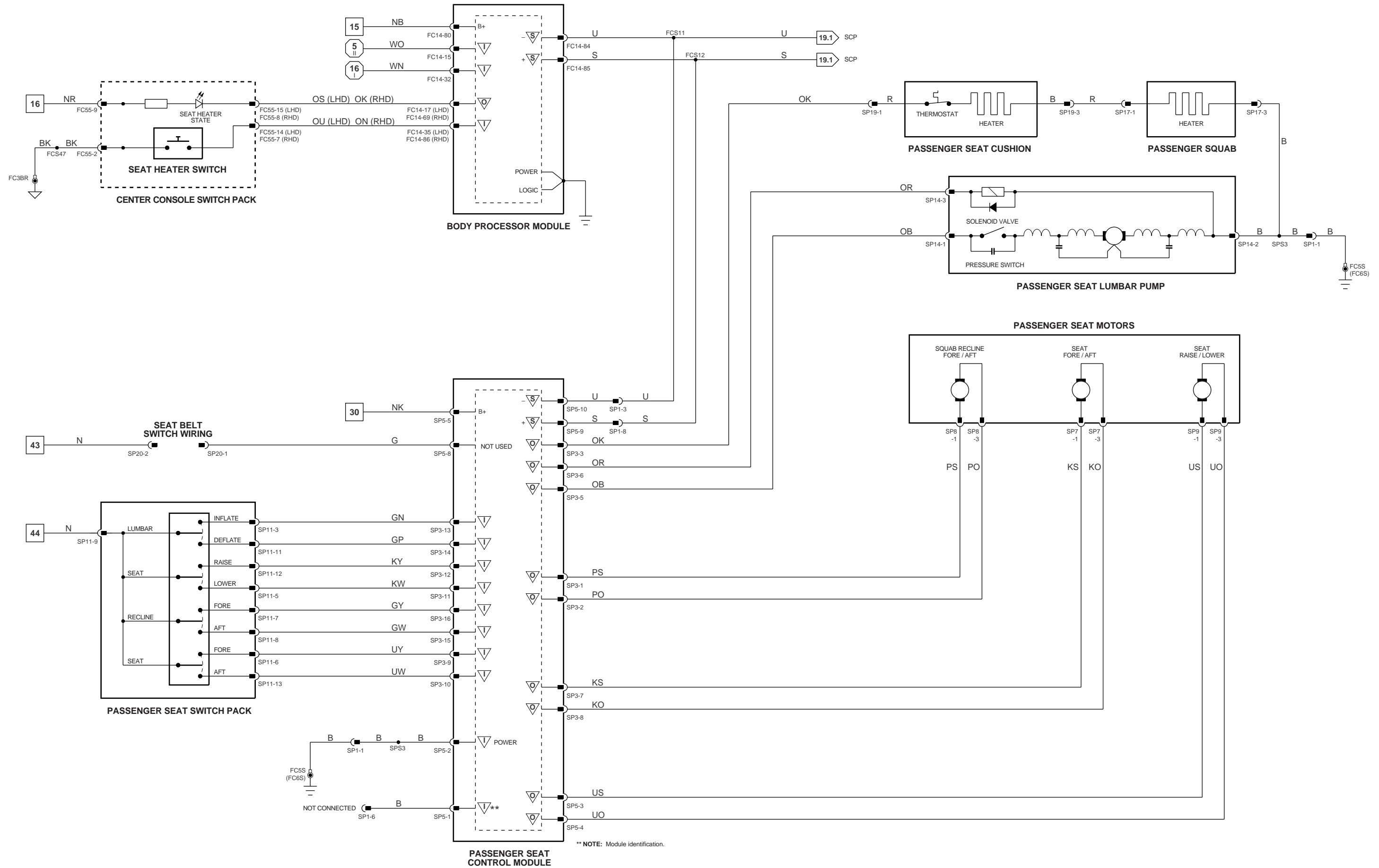

VARIANT: 3-Way Movement Vehicles
 VIN RANGE: 018108 →
 DATE OF ISSUE: SEPTEMBER 1997

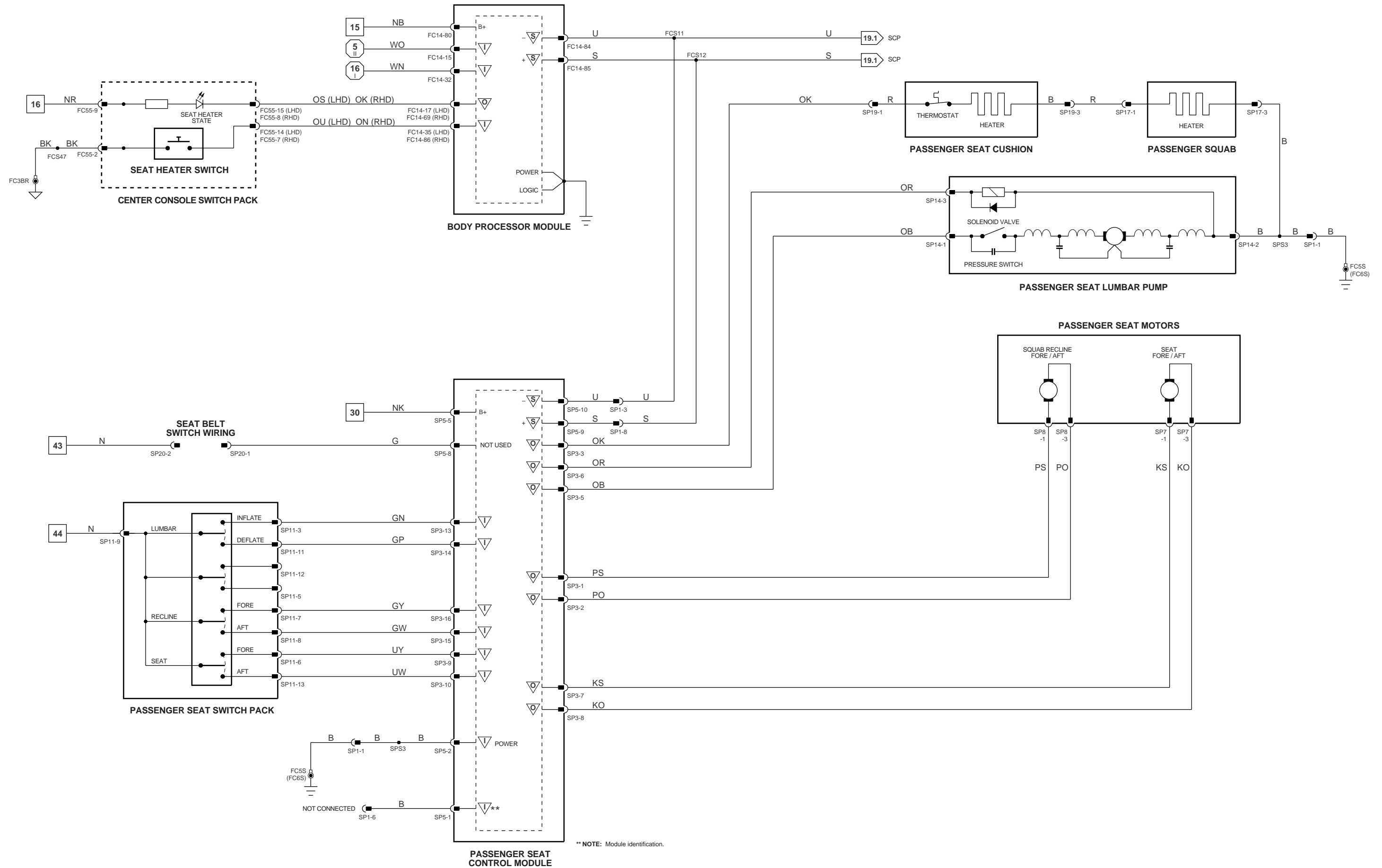

▽ Input ▽ Output
 ▽ Signal Ground (SG) ▽ CAN (Network)
 ▽ Serial and Encoded Communications
 ▽ SCP Network

VARIANT: 2-Way Movement Vehicles
 VIN RANGE: 018108 →
 DATE OF ISSUE: SEPTEMBER 1997

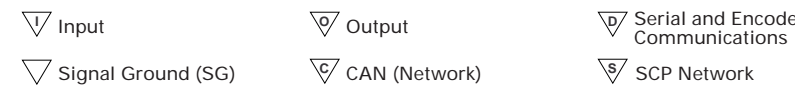
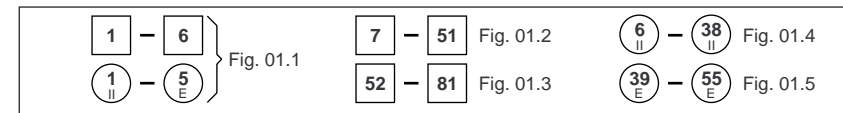
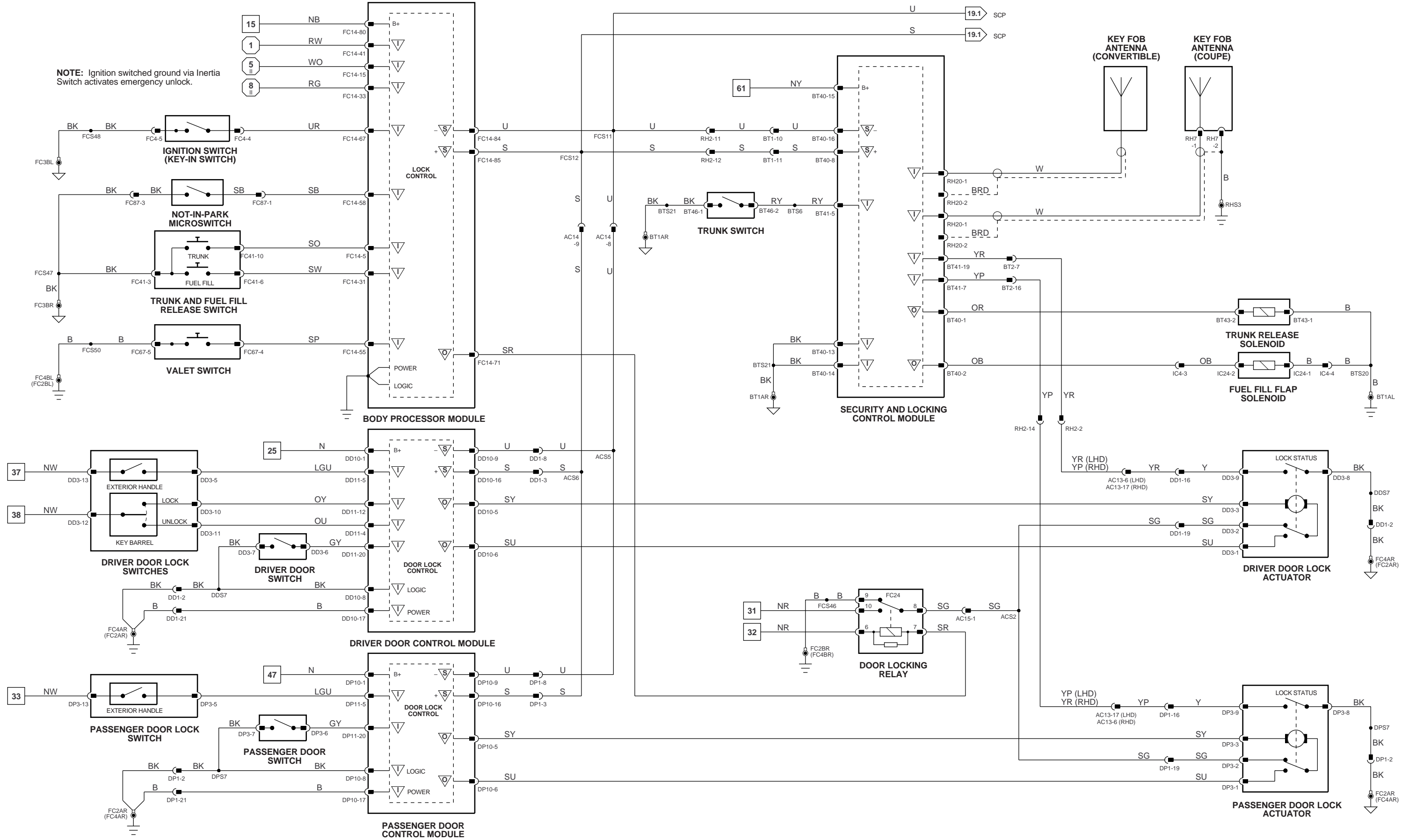

VARIANT: All Vehicles
 VIN RANGE: 018108 →
 DATE OF ISSUE: SEPTEMBER 1997

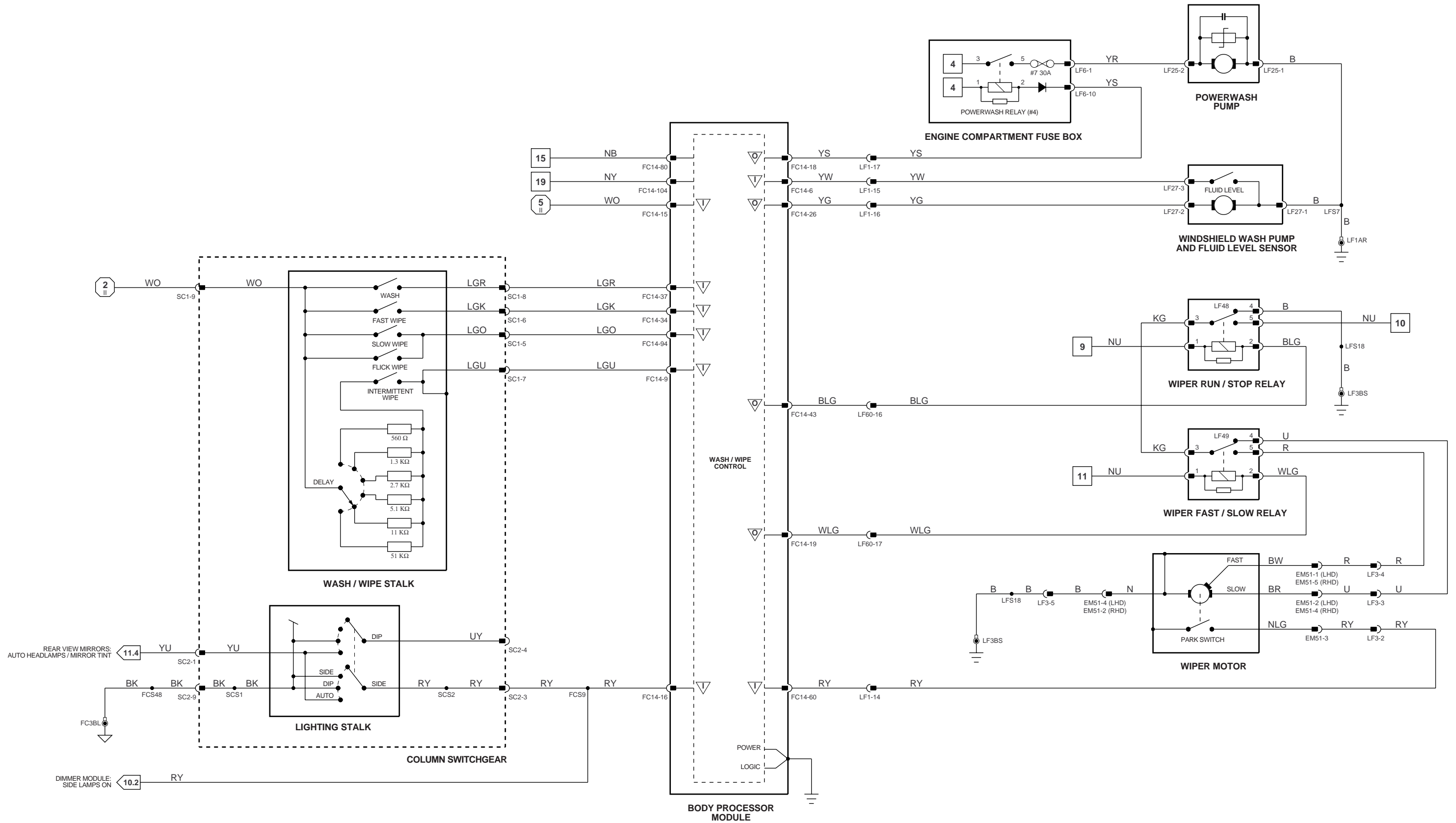
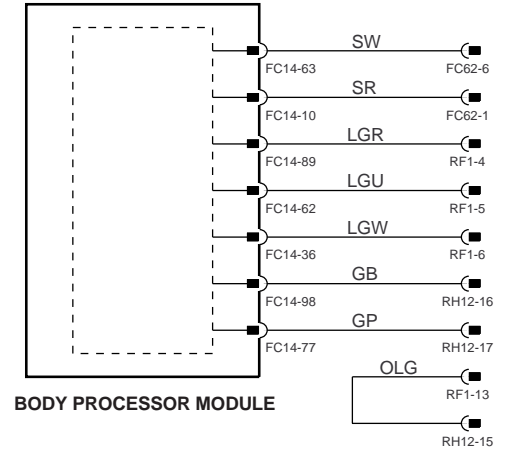
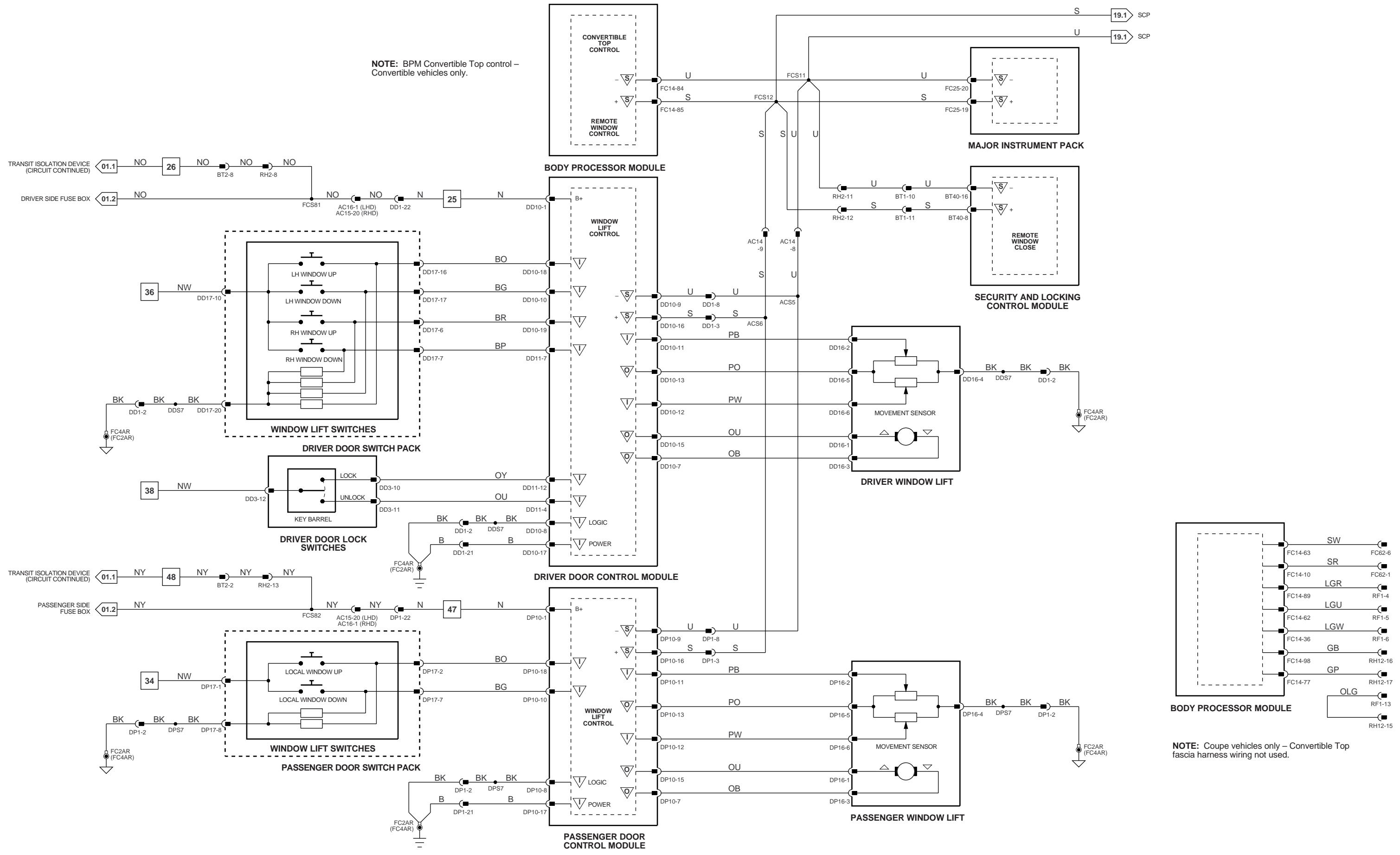
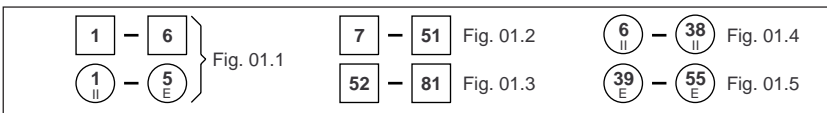

Fig. 01.1	Fig. 01.2	Fig. 01.4	Fig. 02.1	Input	Output	Serial and Encoded Communications
Fig. 01.1	Fig. 01.3	Fig. 01.5		Signal Ground (SG)	CAN (Network)	SCP Network

VARIANT: All Vehicles
 VIN RANGE: 018108 →
 DATE OF ISSUE: SEPTEMBER 1997



NOTE: Coupe vehicles only – Convertible Top fascia harness wiring not used.



VARIANT: All Vehicles
VIN RANGE: 018108 →
DATE OF ISSUE: SEPTEMBER 1997

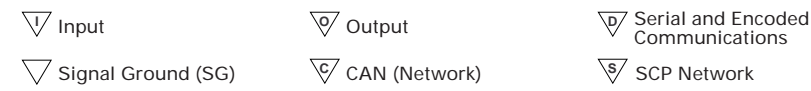
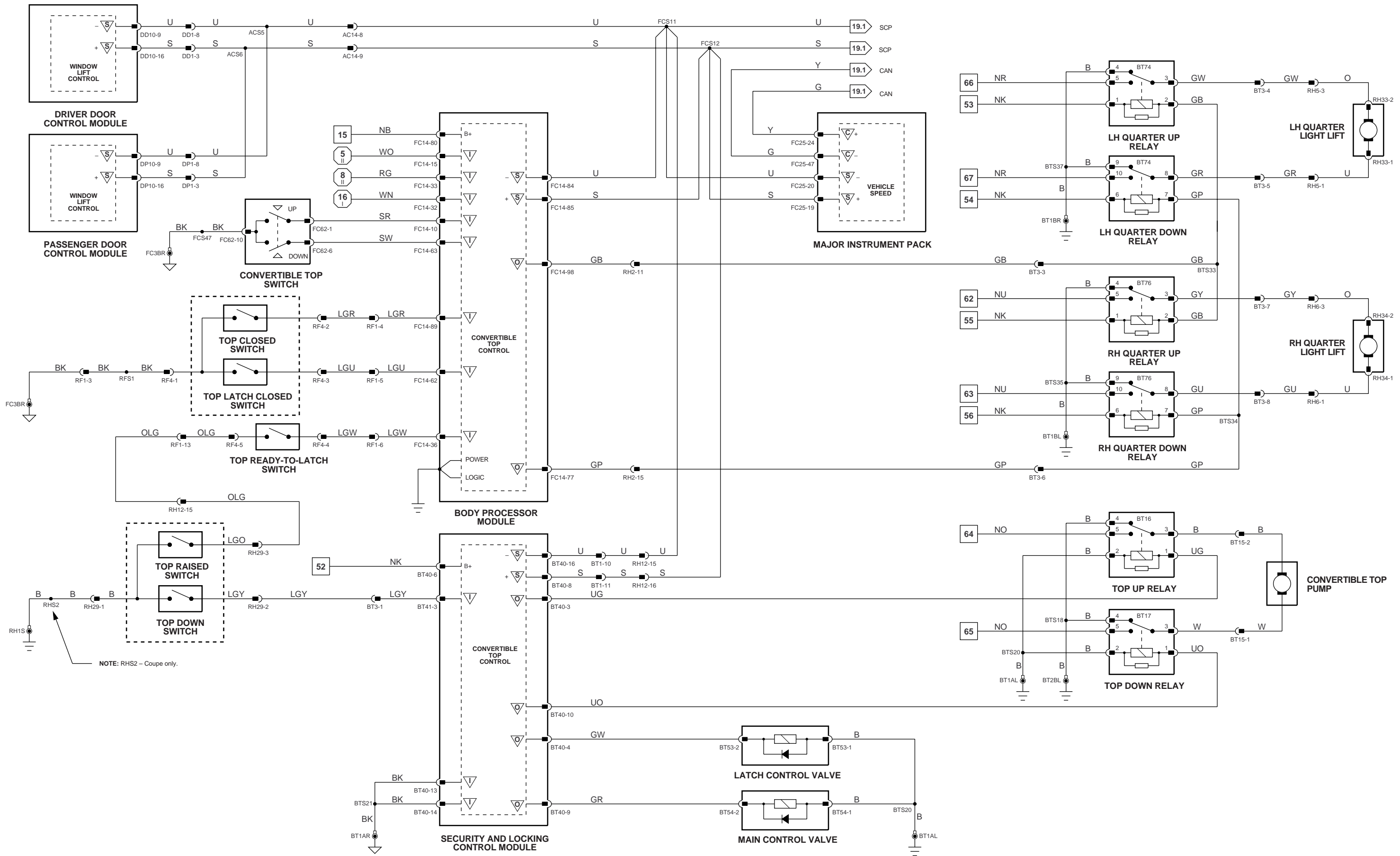

VARIANT: Convertible Vehicles
 VIN RANGE: 018108 →
 DATE OF ISSUE: SEPTEMBER 1997

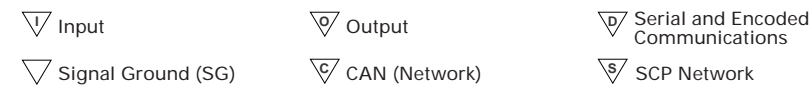
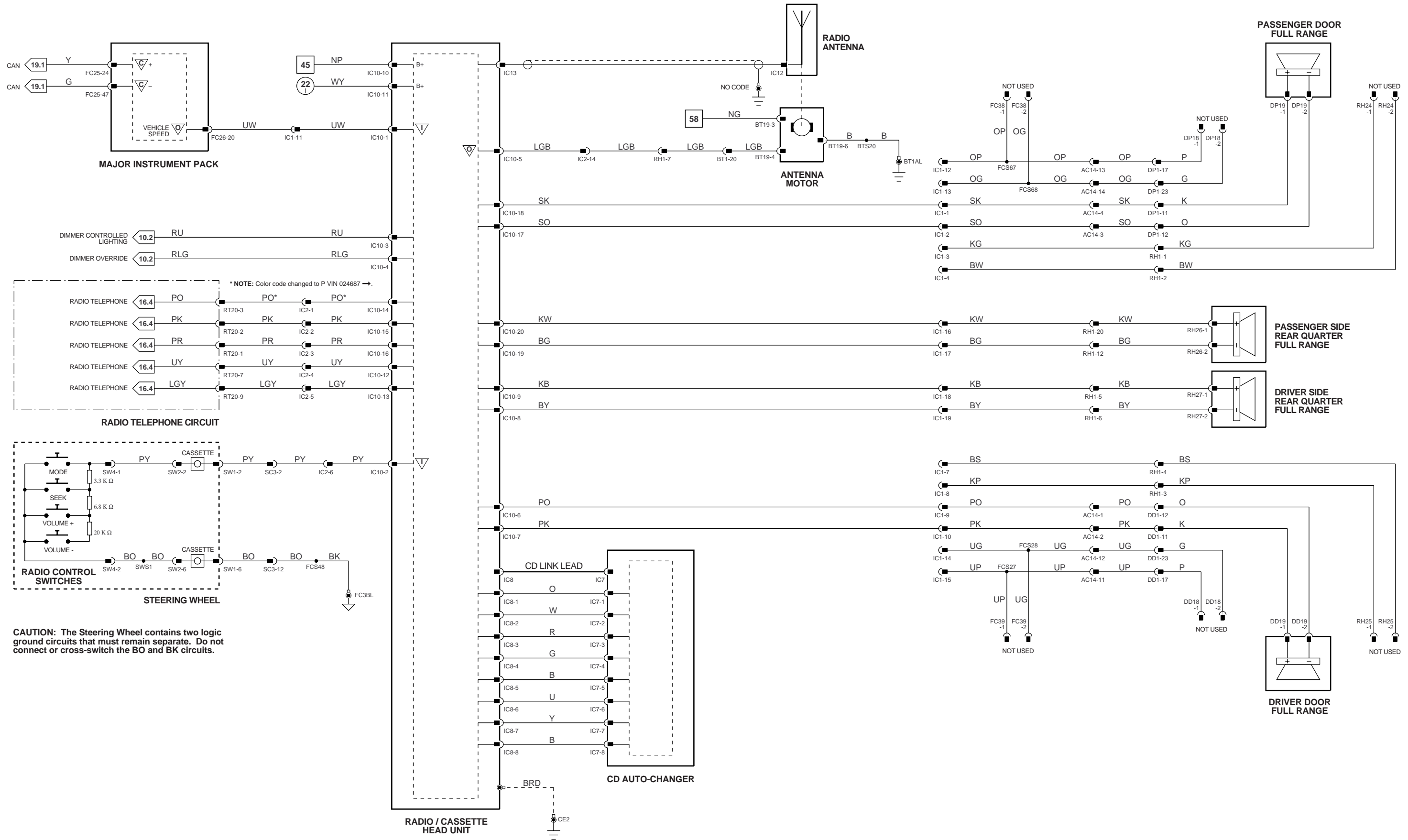

VARIANT: Convertible Vehicles
 VIN RANGE: 018108 →
 DATE OF ISSUE: FEBRUARY 1998

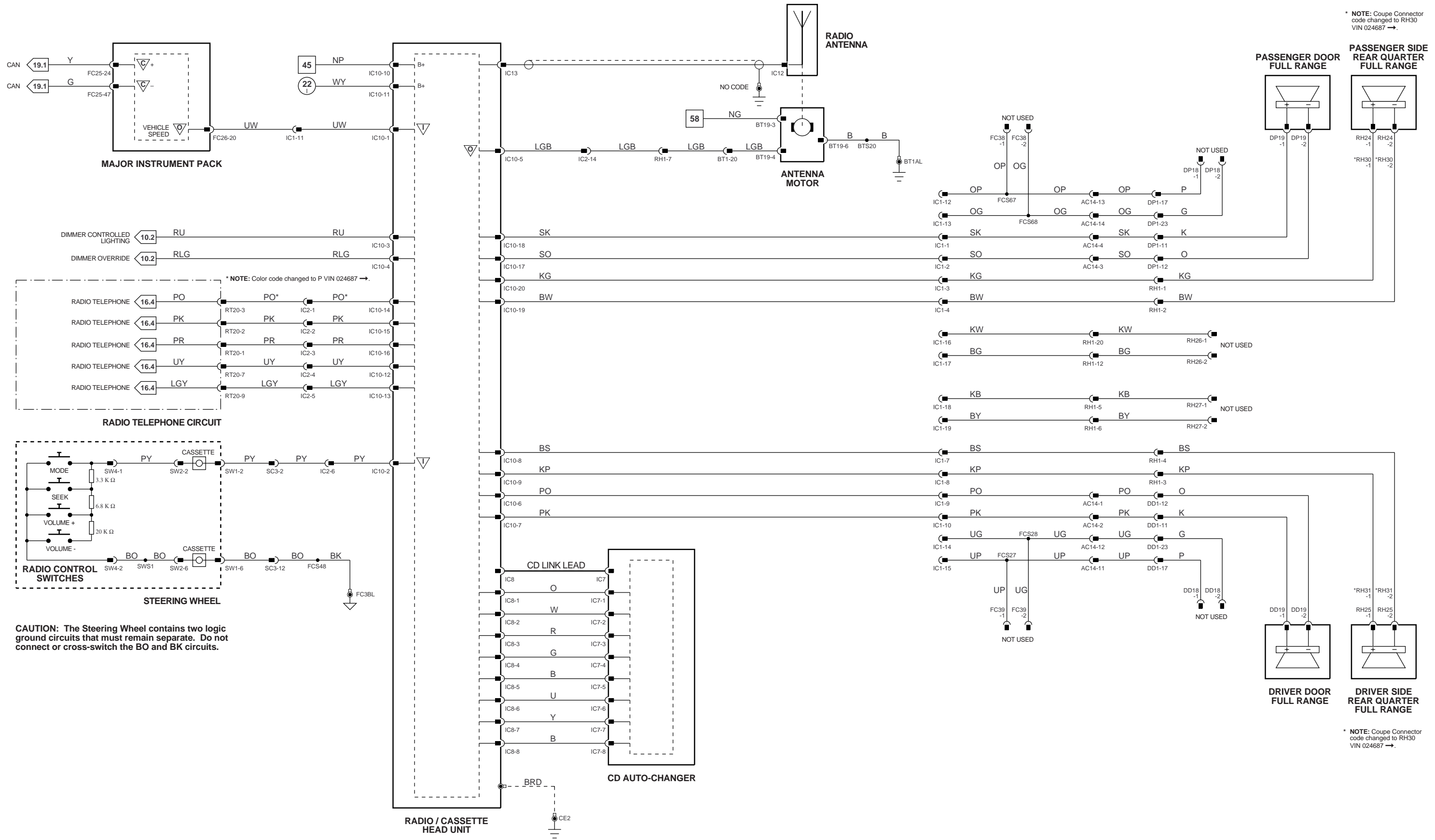

* NOTE: Coupe Connector code changed to RH30 VIN 024687 →.

* NOTE: Color code changed to P VIN 024687 →.

* NOTE: Coupe Connector code changed to RH30 VIN 024687 →.

CAUTION: The Steering Wheel contains two logic ground circuits that must remain separate. Do not connect or cross-switch the BO and BK circuits.

	Fig. 01.1	Fig. 01.2	Fig. 01.3	Fig. 01.4	Fig. 01.5	Fig. 02.1	Input	Output	Serial and Encoded Communications
							Signal Ground (SG)	CAN (Network)	SCP Network

VARIANT: Coupe Vehicles
 VIN RANGE: 018108 →
 DATE OF ISSUE: FEBRUARY 1998

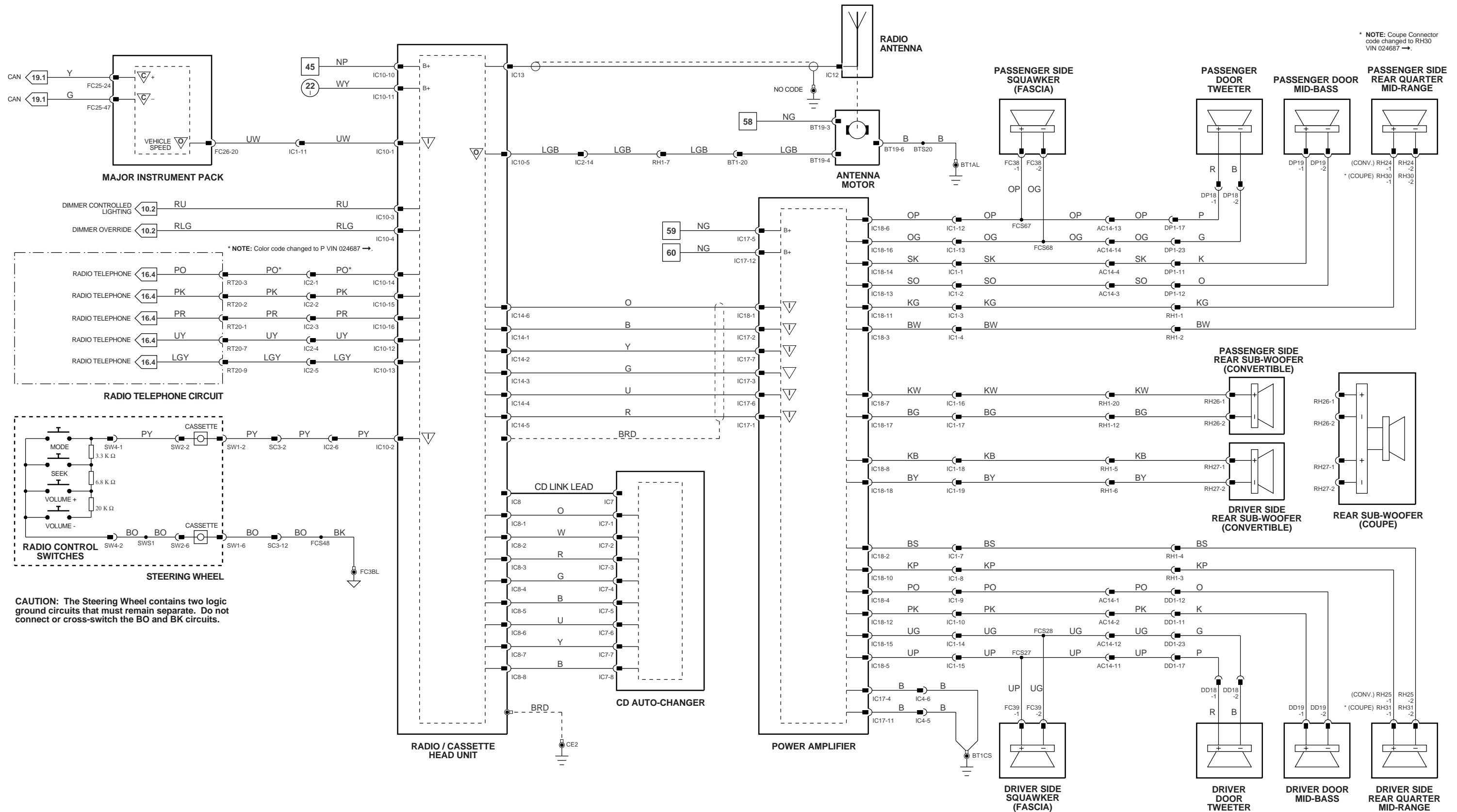

* NOTE: Coupe Connector code changed to RH30 VIN 024687 →.

* NOTE: Coupe Connector code changed to RH31 VIN 024687 →.

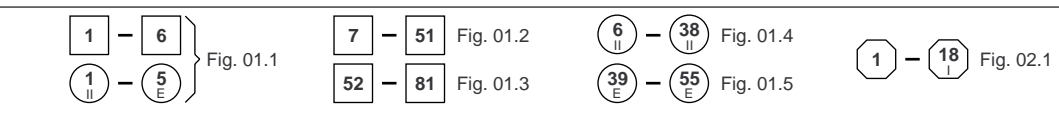

VARIANT: Premium ICE Vehicles
 VIN RANGE: 018108 →
 DATE OF ISSUE: FEBRUARY 1998

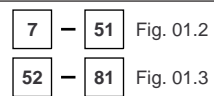
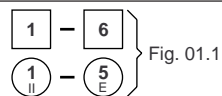
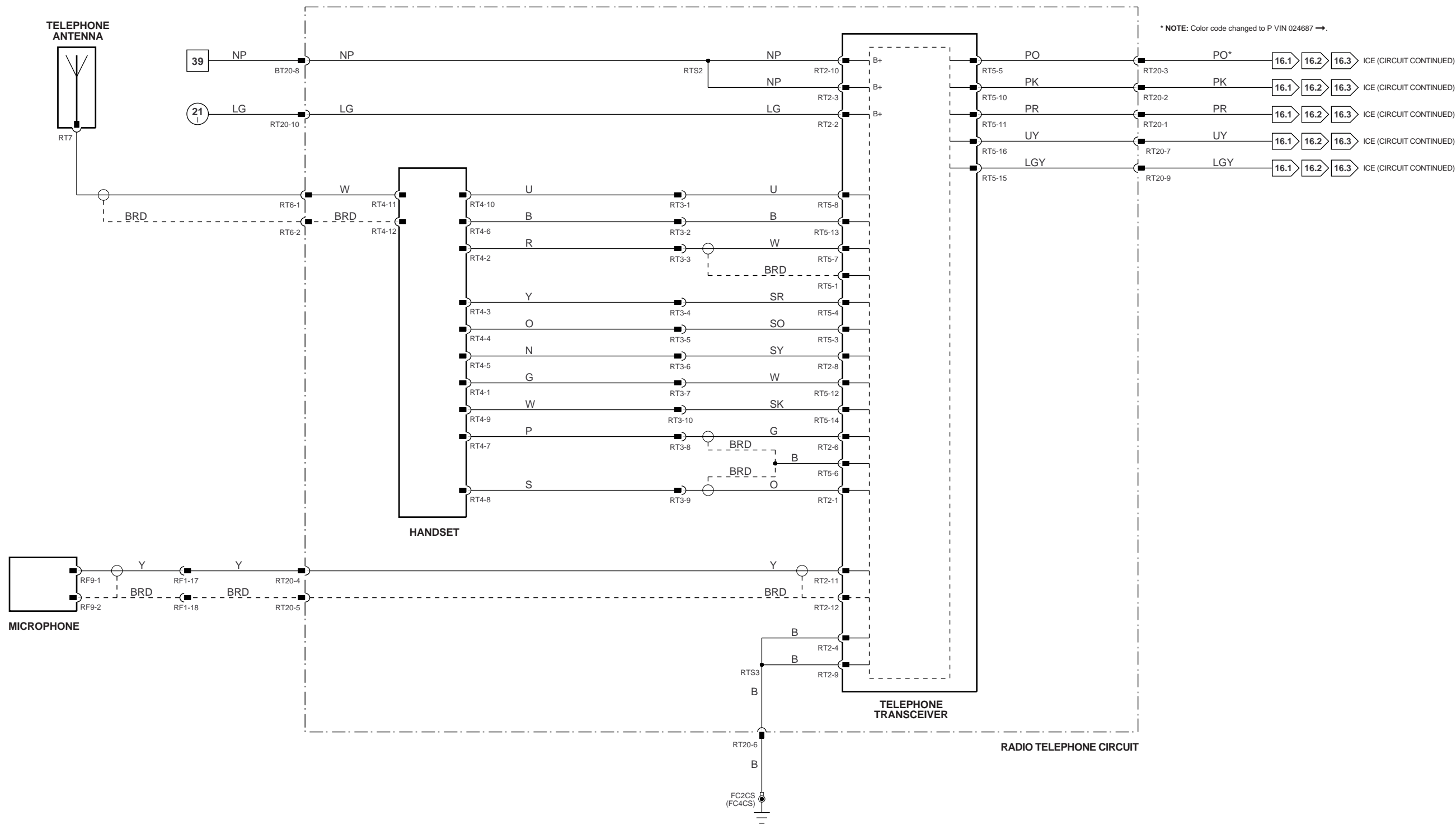

▽ Input

▽ Output

▽ Signal Ground (SG)

▽ CAN (Network)

▽ Serial and Encoded Communications

▽ SCP Network

VARIANT: All Vehicles
VIN RANGE: 018108 →
DATE OF ISSUE: FEBRUARY 1998



CAUTION: Do not substitute another fuse value for the Airbag System 10A Battery fuse.

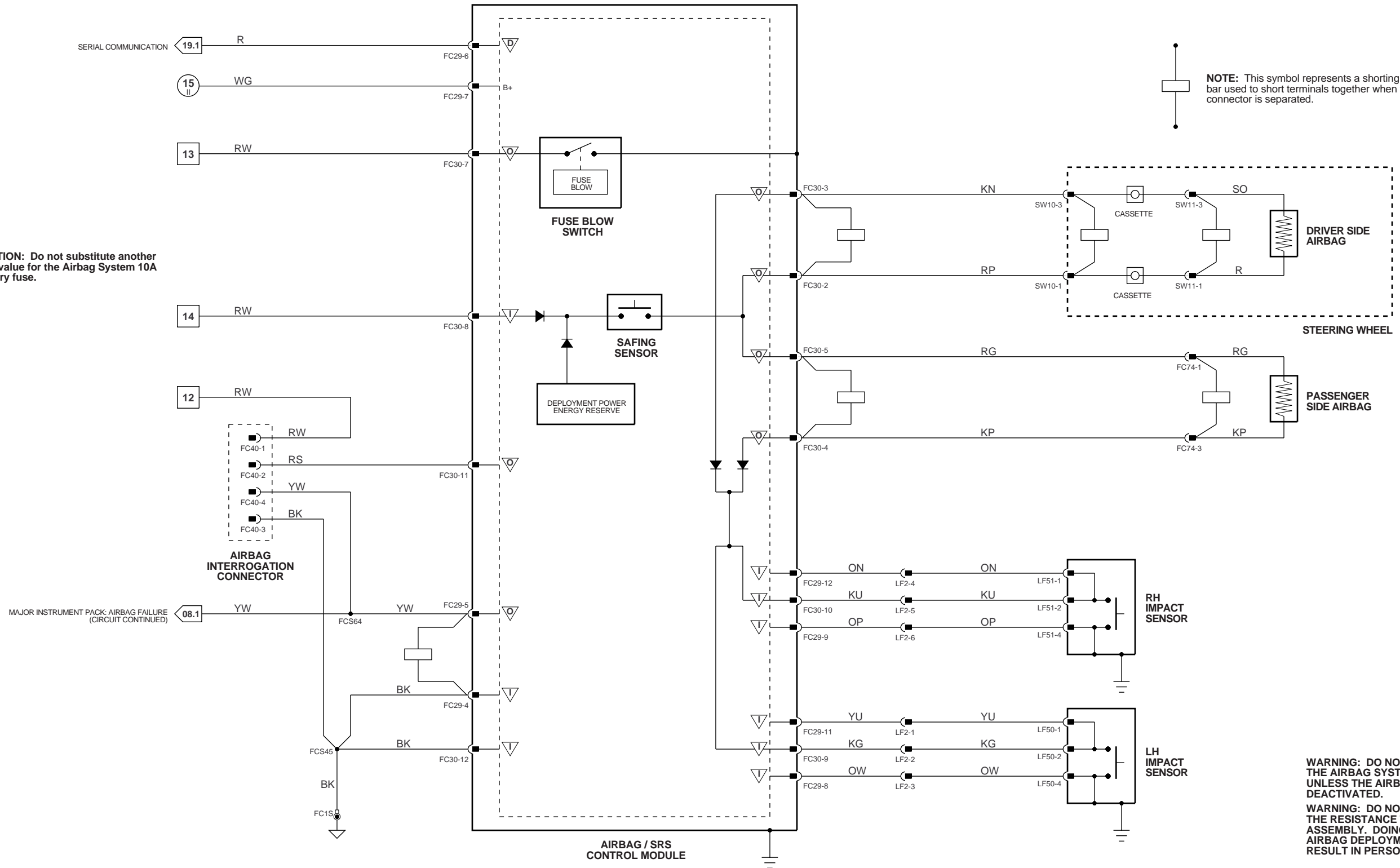

NOTE: This symbol represents a shorting bar used to short terminals together when the connector is separated.

WARNING: DO NOT ATTEMPT TO REPLACE THE AIRBAG SYSTEM 10A BATTERY FUSE UNLESS THE AIRBAG SYSTEM HAS BEEN DEACTIVATED.

WARNING: DO NOT ATTEMPT TO MEASURE THE RESISTANCE THROUGH THE AIRBAG ASSEMBLY. DOING SO MAY TRIGGER AIRBAG DEPLOYMENT AND POSSIBLY RESULT IN PERSONAL INJURY.

1 - 6 } Fig. 01.1	7 - 51 } Fig. 01.2	6 - 38 } Fig. 01.4	1 - 18 } Fig. 02.1	▽ Input	▽ Output	▽ Serial and Encoded Communications
1 - 5 } Fig. 01.1	52 - 81 } Fig. 01.3	39 - 55 } Fig. 01.5		▽ Signal Ground (SG)	▽ CAN (Network)	▽ SCP Network

VARIANT: All Vehicles
 VIN RANGE: 018108 →
 DATE OF ISSUE: SEPTEMBER 1997

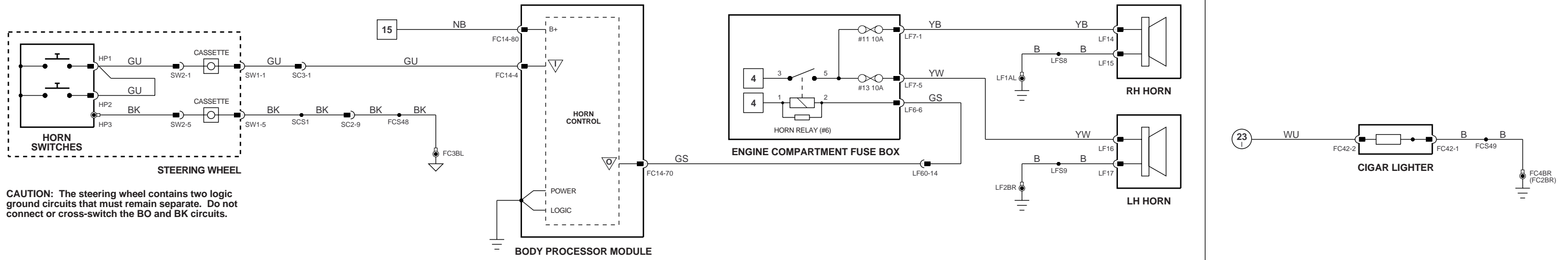

CAUTION: The steering wheel contains two logic ground circuits that must remain separate. Do not connect or cross-switch the BO and BK circuits.

HORNS

CIGAR LIGHTER

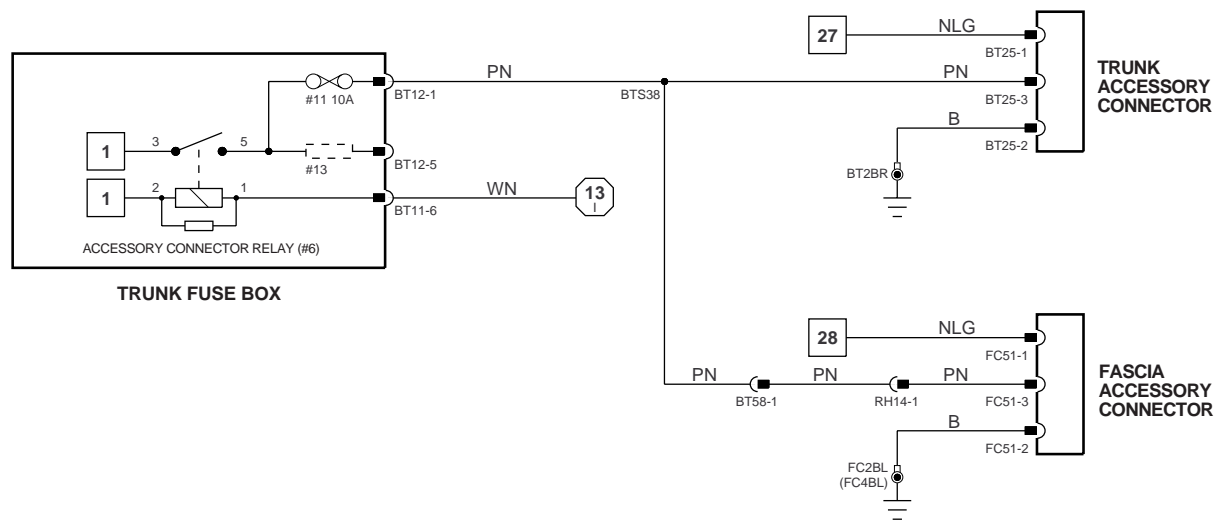

ACCESSORY CONNECTORS

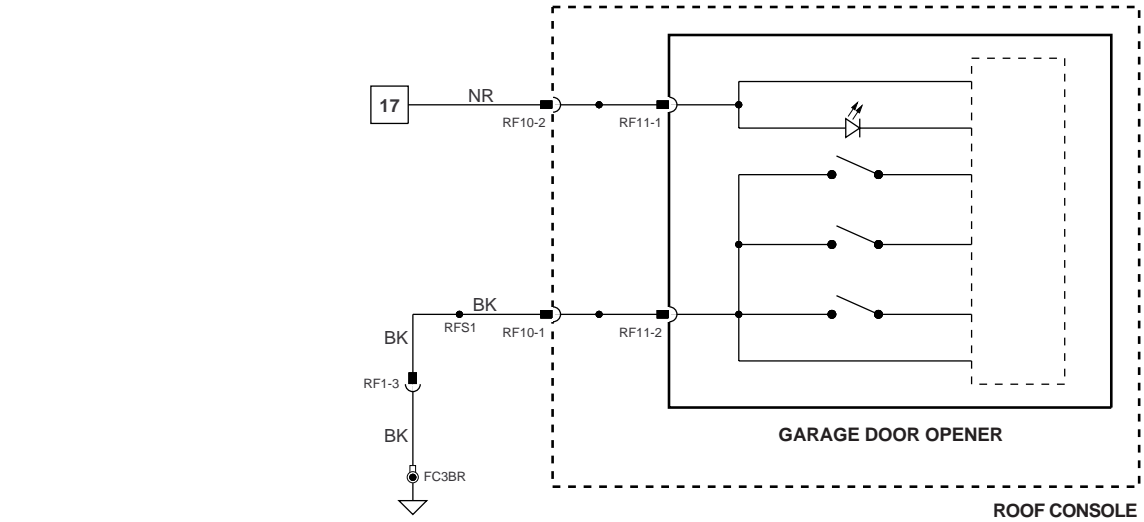

GARAGE DOOR OPENER

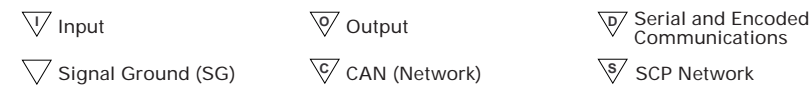

VARIANT: All Vehicles
 VIN RANGE: 018108 →
 DATE OF ISSUE: SEPTEMBER 1997

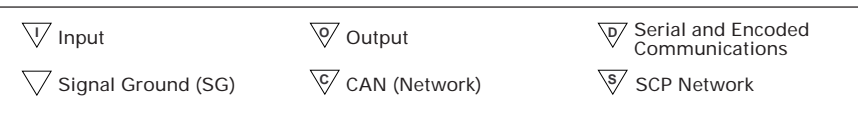
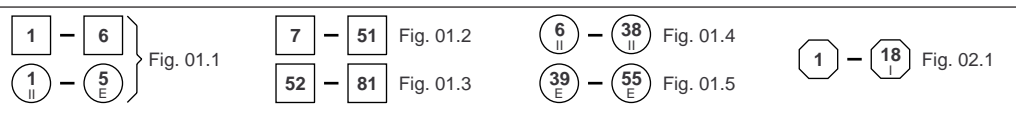
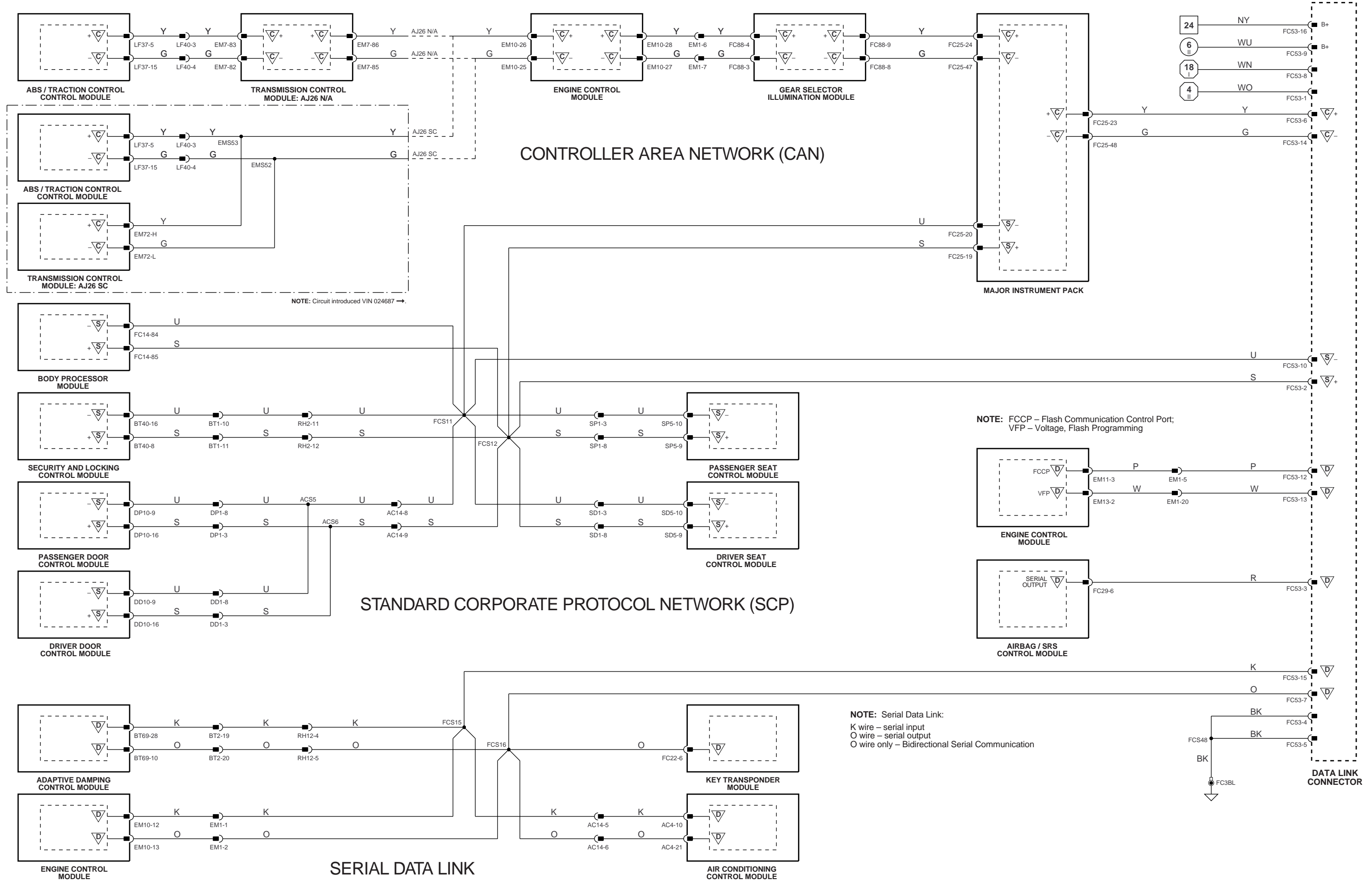

VARIANT: All Vehicles
 VIN RANGE: 018108 →
 DATE OF ISSUE: FEBRUARY 1998

CONTROL MODULE PIN OUT INFORMATION

BODY PROCESSOR MODULE

Pin	Description	Active	Inactive
I FC14-15	IGNITION SWITCHED GROUND SUPPLY	GROUND	
I FC14-32	IGNITION SWITCHED GROUND SUPPLY	GROUND	
O FC14-97	RELAY COIL DRIVE		GROUND

Fig. 01.1

COMPONENTS

Component	Connector / Type / Color	Location / Access
BATTERY	BT66 / EYELET BT67 / EYELET	TRUNK, RIGHT HAND SIDE
BODY PROCESSOR MODULE	FC14 / 104-WAY AMP EEEC / GREY	PASSENGER SIDE FASCIA / AIRBAG BRACKET
FUSE BOX - DRIVER SIDE	FC5 / 10-WAY U.T.A. FUSEBOX / NATURAL FC6 / 10-WAY U.T.A. FUSEBOX / BLACK FC90 / EYELET FC92 / EYELET	FASCIA / DRIVER SIDE
FUSE BOX - ENGINE COMPARTMENT	LF5 / 10-WAY U.T.A. FUSEBOX / NATURAL LF6 / 10-WAY U.T.A. FUSEBOX / BLACK LF7 / 10-WAY U.T.A. FUSEBOX / GREEN LF8 / 10-WAY U.T.A. FUSEBOX / BLUE LF70 / EYELET	ENGINE COMPARTMENT / LEFT FRONT
FUSE BOX - ENGINE MANAGEMENT	EM19 / 10-WAY U.T.A. FUSEBOX / NATURAL EM20 / 10-WAY U.T.A. FUSEBOX / BLACK EM70 / EYELET	ENGINE COMPARTMENT / CONTROL MODULE ENCLOSURE
FUSE BOX - PASSENGER SIDE	FC20 / 10-WAY U.T.A. FUSEBOX / NATURAL FC21 / 10-WAY U.T.A. FUSEBOX / BLACK FC90 / EYELET FC93 / EYELET	FASCIA / PASSENGER SIDE
FUSE BOX - TRUNK	BT10 / 10-WAY U.T.A. FUSEBOX / NATURAL BT11 / 10-WAY U.T.A. FUSEBOX / BLACK BT12 / 10-WAY U.T.A. FUSEBOX / GREEN BT13 / 10-WAY U.T.A. FUSEBOX / BLUE BT64 / EYELET	TRUNK / ELECTRICAL CARRIER
HIGH POWER PROTECTION MODULE	BT60 / EYELET BT61 / EYELET BT62 / EYELET BT63 / EYELET	TRUNK / ADJACENT TO BATTERY
TRANSIT ISOLATION DEVICE	BT44 / 2-WAY ECONOSEAL III HC / BLACK BT49 / 1-WAY LUCAR BT65 / EYELET BT66 / EYELET	TRUNK / ADJACENT TO BATTERY

RELAYS

Relay	Color / Stripe	Connector / Color	Location / Access
AUXILIARY POSITIVE RELAY	BROWN	BUS	PASSENGER SIDE FUSE BOX
EMS CONTROL RELAY	BROWN	BUS	ENGINE MANAGEMENT FUSE BOX
IGNITION POSITIVE RELAY	BROWN	BUS	DRIVER SIDE FUSE BOX
IGNITION POSITIVE RELAY	BROWN	BUS	ENGINE COMPARTMENT FUSE BOX
IGNITION POSITIVE RELAY	BROWN	BUS	TRUNK FUSE BOX

HARNESSTO-HARNESSTO CONNECTORS

Connector	Type / Color	Location / Access
BT2	20-WAY MULTILOCK 070 / WHITE	TRUNK / ABOVE RIGHT HAND REAR WHEEL ARCH
BT79	EYELET	TRANSMISSION TUNNEL
BT80	EYELET	ENGINE COMPARTMENT / FALSE BULKHEAD, RIGHT HAND SIDE
EM71	EYELET	TRANSMISSION TUNNEL
FC91	EYELET	TRANSMISSION TUNNEL
LF71	EYELET	TRANSMISSION TUNNEL
RH2	20-WAY MULTILOCK 070 / WHITE	REAR OF CENTER CONSOLE ASSEMBLY
ST1	EYELET	ENGINE COMPARTMENT / FALSE BULKHEAD, RIGHT HAND SIDE

GROUNDS

Ground	Location / Type
BT68	BATTERY GROUND STUD
BT2BR	EYELET (PAIR) - RIGHT HAND LEG / TRUNK, RIGHT REAR
BT2BS	EYELET (SINGLE) / TRUNK, RIGHT REAR

CONTROL MODULE PIN OUT INFORMATION (FOLD OUT PAGE)



The following symbols are used to represent values for Control Module Pin Out data:

I Input	D Serial and encoded communications	B+ Battery voltage	KHz Frequency x 1000
O Output	C CAN (Network)	V Voltage (DC)	MS Milliseconds
SG Signal Ground	S SCP Network	Hz Frequency	MV Millivolts

CAUTION: The information on this data page is furnished to aid the user in understanding circuit operation. THIS INFORMATION SHOULD BE USED FOR REFERENCE ONLY.

NOTE: The values listed are approximately those that can be expected at the control module connector pins with all circuit connections made and all components connected and fitted. "Active" means a load is applied or a switch is ON; "Inactive" means a load is not applied or a switch is OFF.

REFER TO THE FRONT OF THE BOOK FOR ILLUSTRATIONS DETAILING THE LOCATION AND IDENTIFICATION OF COMPONENTS, RELAYS, CONNECTORS, HARNESSES, GROUNDS, VEHICLE CONTROL MODULES AND CONTROL MODULE PINS.

Fig. 01.2**COMPONENTS**

Component	Connector / Type / Color	Location / Access
FUSE BOX - DRIVER SIDE	FC5 / 10-WAY U.T.A. FUSEBOX / NATURAL FC6 / 10-WAY U.T.A. FUSEBOX / BLACK FC90 / EYELET FC92 / EYELET	FASCIA / DRIVER SIDE
FUSE BOX - PASSENGER SIDE	FC20 / 10-WAY U.T.A. FUSEBOX / NATURAL FC21 / 10-WAY U.T.A. FUSEBOX / BLACK FC90 / EYELET FC93 / EYELET	FASCIA / PASSENGER SIDE

HARNESS-TO-HARNESS CONNECTORS

Connector	Type / Color	Location / Access
AC12	20-WAY MULTILOCK 070 / WHITE	FASCIA TOP CONNECTOR MOUNTING BRACKET / RIGHT HAND SIDE
AC13	20-WAY MULTILOCK 070 / YELLOW	FASCIA BOTTOM CONNECTOR MOUNTING BRACKET / RIGHT HAND SIDE
AC14	14-WAY MULTILOCK 070 / GREY	FASCIA BOTTOM CONNECTOR MOUNTING BRACKET / RIGHT HAND SIDE
AC15	20-WAY MULTILOCK 070 / GREY	FASCIA BOTTOM CONNECTOR MOUNTING BRACKET / RIGHT HAND SIDE
AC16	6 WAY MULTILOCK 070 / YELLOW	LEFT HAND 'A' POST CONNECTOR MOUNTING BRACKET / 'A' POST TRIM
BT2	20-WAY MULTILOCK 070 / WHITE	TRUNK / ABOVE RIGHT HAND REAR WHEEL ARCH
BT58	4-WAY ECONOSEAL III HC / BLACK	TRUNK / ABOVE RIGHT HAND REAR WHEEL ARCH
DD1	23-WAY AMP - FORD / BLACK	DRIVER SIDE 'A' POST MOUNTING BRACKET / 'A' POST TRIM
DP1	23-WAY AMP - FORD / BLACK	PASSENGER SIDE 'A' POST / 'A' POST TRIM
IC2	14-WAY MULTILOCK 070 / WHITE	BELOW CENTER CONSOLE GLOVE BOX
LF1	20-WAY MULTILOCK 070 / GREY	LEFT HAND 'A' POST CONNECTOR MOUNTING BRACKET / 'A' POST TRIM
RF1	18-WAY MULTILOCK 070 / YELLOW	RIGHT HAND 'A' POST CONNECTOR MOUNTING BRACKET / 'A' POST TRIM
RH14	2-WAY ECONOSEAL III HC / BLACK	REAR OF CENTER CONSOLE ASSEMBLY
RH2	20-WAY MULTILOCK 070 / WHITE	REAR OF CENTER CONSOLE ASSEMBLY
SD1	8-WAY MULTILOCK 070 / YELLOW	BELOW DRIVER SEAT
SP1	8-WAY MULTILOCK 070 / YELLOW	BELOW PASSENGER SEAT

REFER TO THE FRONT OF THE BOOK FOR ILLUSTRATIONS DETAILING THE LOCATION AND IDENTIFICATION OF COMPONENTS, RELAYS, CONNECTORS, HARNESSES, GROUNDS, VEHICLE CONTROL MODULES AND CONTROL MODULE PINS.

Fig. 01.3

COMPONENTS

Component	Connector / Type / Color	Location / Access
FUSE BOX - ENGINE COMPARTMENT	LF5 / 10-WAY U.T.A. FUSEBOX / NATURAL LF6 / 10-WAY U.T.A. FUSEBOX / BLACK LF7 / 10-WAY U.T.A. FUSEBOX / GREEN LF8 / 10-WAY U.T.A. FUSEBOX / BLUE LF70 / EYELET	ENGINE COMPARTMENT / LEFT FRONT
FUSE BOX - ENGINE MANAGEMENT	EM19 / 10-WAY U.T.A. FUSEBOX / NATURAL EM20 / 10-WAY U.T.A. FUSEBOX / BLACK EM70 / EYELET	ENGINE COMPARTMENT / CONTROL MODULE ENCLOSURE
FUSE BOX - TRUNK	BT10 / 10-WAY U.T.A. FUSEBOX / NATURAL BT11 / 10-WAY U.T.A. FUSEBOX / BLACK BT12 / 10-WAY U.T.A. FUSEBOX / GREEN BT13 / 10-WAY U.T.A. FUSEBOX / BLUE BT64 / EYELET	TRUNK / ELECTRICAL CARRIER

HARNESS-TO-HARNESS CONNECTORS

Connector	Type / Color	Location / Access
IC4	4-WAY MULTILOCK 070 / WHITE	TRUNK / LEFT OF ANTENNA ASSEMBLY

REFER TO THE FRONT OF THE BOOK FOR ILLUSTRATIONS DETAILING THE LOCATION AND IDENTIFICATION OF COMPONENTS, RELAYS, CONNECTORS, HARNESES, GROUNDS, VEHICLE CONTROL MODULES AND CONTROL MODULE PINS.

Fig. 01.4**COMPONENTS**

Component	Connector / Type / Color	Location / Access
FUSE BOX - DRIVER SIDE	FC5 / 10-WAY U.T.A. FUSEBOX / NATURAL FC6 / 10-WAY U.T.A. FUSEBOX / BLACK FC90 / EYELET FC92 / EYELET	FASCIA / DRIVER SIDE
FUSE BOX - ENGINE COMPARTMENT	LF5 / 10-WAY U.T.A. FUSEBOX / NATURAL LF6 / 10-WAY U.T.A. FUSEBOX / BLACK LF7 / 10-WAY U.T.A. FUSEBOX / GREEN LF8 / 10-WAY U.T.A. FUSEBOX / BLUE LF70 / EYELET	ENGINE COMPARTMENT / LEFT FRONT
FUSE BOX - PASSENGER SIDE	FC20 / 10-WAY U.T.A. FUSEBOX / NATURAL FC21 / 10-WAY U.T.A. FUSEBOX / BLACK FC90 / EYELET FC98 / EYELET	FASCIA / PASSENGER SIDE
FUSE BOX - TRUNK	BT10 / 10-WAY U.T.A. FUSEBOX / NATURAL BT11 / 10-WAY U.T.A. FUSEBOX / BLACK BT12 / 10-WAY U.T.A. FUSEBOX / GREEN BT13 / 10-WAY U.T.A. FUSEBOX / BLUE BT64 / EYELET	TRUNK / ELECTRICAL CARRIER

HARNESS-TO-HARNESS CONNECTORS

Connector	Type / Color	Location / Access
AC15	20-WAY MULTILOCK 070 / GREY	FASCIA BOTTOM CONNECTOR MOUNTING BRACKET / RIGHT HAND SIDE
EM2	18-WAY MULTILOCK 070 / YELLOW	ENGINE COMPARTMENT / ADJACENT TO RIGHT HAND ENCLOSURE
IC2	14-WAY MULTILOCK 070 / WHITE	BELOW CENTER CONSOLE GLOVE BOX
LF3	13-WAY ECONOSEAL III LC / WHITE	ENGINE COMPARTMENT / LEFT HAND ENCLOSURE
LF40	13-WAY ECONOSEAL III LC / BLACK	ENGINE COMPARTMENT / LEFT HAND ENCLOSURE
LF60	20-WAY MULTILOCK 070 / WHITE	LEFT HAND 'A' POST CONNECTOR MOUNTING BRACKET / 'A' POST TRIM
PI2	13-WAY ECONOSEAL III LC / BLACK	ENGINE COMPARTMENT / BRACKET ON TOP OF TRANSMISSION
RF1	18-WAY MULTILOCK 070 / YELLOW	RIGHT HAND 'A' POST CONNECTOR MOUNTING BRACKET / 'A' POST TRIM

Fig. 01.5

COMPONENTS

Component

FUSE BOX - ENGINE MANAGEMENT

Connector / Type / Color

EM19 / 10-WAY U.T.A. FUSEBOX / NATURAL
EM20 / 10-WAY U.T.A. FUSEBOX / BLACK
EM70 / EYELET

Location / Access

ENGINE COMPARTMENT / CONTROL MODULE ENCLOSURE

HARNESSTO-HARNESSTO CONNECTORS

Connector

Type / Color

EL1 6-WAY ECONOSEAL III LC / BLACK
LF3 13-WAY ECONOSEAL III LC / WHITE
LF40 13-WAY ECONOSEAL III LC / BLACK
P11 57-WAY SUMITOMO / BLACK

Location / Access

ENGINE COMPARTMENT / RIGHT HAND ENCLOSURE
ENGINE COMPARTMENT / LEFT HAND ENCLOSURE
ENGINE COMPARTMENT / LEFT HAND ENCLOSURE
ENGINE COMPARTMENT / BRACKET ON TOP OF TRANSMISSION

REFER TO THE FRONT OF THE BOOK FOR ILLUSTRATIONS DETAILING THE LOCATION AND IDENTIFICATION OF COMPONENTS, RELAYS, CONNECTORS, HARNESSES, GROUNDS, VEHICLE CONTROL MODULES AND CONTROL MODULE PINS.

Fig. 02.1**COMPONENTS****Component**IGNITION SWITCH (KEY-IN SWITCH)
INERTIA SWITCH**Connector / Type / Color**FC4 / 8-WAY MULTILOCK 070 / WHITE
FC46 / 3-WAY ECONOSEAL III LC / BLACK**Location / Access**STEERING COLUMN
ADJACENT TO LEFT HAND FASCIA FUSE BOX**HARNESS-TO-HARNESS CONNECTORS****Connector****Type / Color**AC13 20-WAY MULTILOCK 070 / YELLOW
BT1 20-WAY MULTILOCK 070 / WHITE
LF60 20-WAY MULTILOCK 070 / WHITE
RH2 20-WAY MULTILOCK 070 / WHITE**Location / Access**FASCIA BOTTOM CONNECTOR MOUNTING BRACKET / RIGHT HAND SIDE
TRUNK / ABOVE RIGHT HAND REAR WHEEL ARCH
LEFT HAND 'A' POST CONNECTOR MOUNTING BRACKET / 'A' POST TRIM
REAR OF CENTER CONSOLE ASSEMBLY**GROUNDS****Ground****Location / Type**

FC3BL EYELET (PAIR) - LEFT HAND LEG / TRANSMISSION TUNNEL, LEFT HAND SIDE

CONTROL MODULE PIN OUT INFORMATION

BODY PROCESSOR MODULE

Pin	Description	Active	Inactive
I FC14-7	NEUTRAL SWITCH STATUS	GROUND (N)	B+ (P, R, D, 4, 3, 2)
D FC14-39	SECURITY ACKNOWLEDGE	ENCODED COMMUNICATIONS	
I FC14-41	STARTER ENGAGE REQUEST	GROUND (CRANKING)	B+
O FC14-73	STARTER RELAY ACTIVATE	GROUND (CRANKING)	B+
I FC14-80	BATTERY SUPPLY VOLTAGE		B-
D FC14-92	ENCODED COMMUNICATIONS		

ENGINE CONTROL MODULE

Pin	Description	Active	Inactive
D EM10-6	OK TO START - ENCODED COMMUNICATIONS		
I EM10-15	PARK / NEUTRAL CONFIRMATION	B+ (P, N)	GROUND (R,D,4,3,2)
D EM10-17	SECURITY ACKNOWLEDGE	ENCODED COMMUNICATIONS	
I EM11-6	ENGINE CRANK	GROUND (CRANKING)	B+

KEY TRANSPONDER MODULE

Pin	Description	Active	Inactive
D FC22-9	GLASS BREAKAGE / OK TO START (ENCODED COMMUNICATION)		
D FC22-16	OK TO START (ENCODED COMMUNICATION)		
D FC22-17	SECURITY ACKNOWLEDGE (ENCODED COMMUNICATION)		

Fig. 03.1

COMPONENTS

Component	Connector / Type / Color	Location / Access
BATTERY	BT66 / EYELET BT67 / EYELET	TRUNK, RIGHT HAND SIDE
BODY PROCESSOR MODULE	FC14 / 104-WAY AMP EEEC / GREY	PASSENGER SIDE FASCIA / AIRBAG BRACKET
ENGINE CONTROL MODULE	EM10 / 28-WAY MULTILOCK 040 / GREY EM11 / 16-WAY MULTILOCK 040 / GREY EM12 / 22-WAY MULTILOCK 040 / GREY EM13 / 34-WAY MULTILOCK 040 / GREY EM14 / 12-WAY MULTILOCK 47 / WHITE EM15 / 22-WAY MULTILOCK 47 / WHITE	ENGINE COMPARTMENT / CONTROL MODULE ENCLOSURE
GENERATOR	AN1 / EYELET AN2 / EYELET ST11 / EYELET	ENGINE COMPARTMENT / RIGHT FRONT
HIGH POWER PROTECTION MODULE	BT60 / EYELET BT61 / EYELET BT62 / EYELET BT63 / EYELET	TRUNK / ADJACENT TO BATTERY
IGNITION SWITCH (KEY-IN SWITCH)	FC4 / 8-WAY MULTILOCK 070 / WHITE	STEERING COLUMN
KEY TRANSPONDER MODULE	FC22 / 20-WAY MULTILOCK 040 / GREEN	ADJACENT TO DRIVER SIDE FUSE BOX
NEUTRAL SWITCH	FC89 / 3-WAY MULTILOCK 070 / GREY	GEAR SELECTOR ASSEMBLY
REGULATOR (GENERATOR)	PI50 / 3-WAY SUMITOMO 0902 / BLACK	ENGINE COMPARTMENT / GENERATOR
STARTER MOTOR	ST2 / EYELET ST3 / EYELET ST10 / EYELET	ENGINE BLOCK
SUPPRESSION MODULE	AN3 / 2-WAY ECONOSEAL III LC / RED	REARWARD OF RIGHT FRONT HEADLAMP

RELAYS

Relay	Color / Stripe	Connector / Color	Location / Access
STARTER RELAY	BROWN	EM50 / BROWN	RH ENCLOSURE RELAYS

HARNESSTO-HARNESSTO CONNECTORS

Connector	Type / Color	Location / Access
BT80	EYELET	ENGINE COMPARTMENT / FALSE BULKHEAD, RIGHT HAND SIDE
EM1	20-WAY MULTILOCK 070 / WHITE	ENGINE COMPARTMENT / ADJACENT TO RIGHT HAND ENCLOSURE
EM2	18-WAY MULTILOCK 070 / YELLOW	ENGINE COMPARTMENT / ADJACENT TO RIGHT HAND ENCLOSURE
EM3	14-WAY MULTILOCK 070 / GREY	ENGINE COMPARTMENT / ADJACENT TO RIGHT HAND ENCLOSURE
EM00	2-WAY ECONOSEAL III HC / BLACK	ENGINE COMPARTMENT / BEHIND LEFT INNER FENDER HEAT SHIELD
PI1	57-WAY SUMITOMO / BLACK	ENGINE COMPARTMENT / BRACKET ON TOP OF TRANSMISSION
ST1	EYELET	ENGINE COMPARTMENT / FALSE BULKHEAD, RIGHT HAND SIDE

GROUNDS

Ground	Location / Type
BT68	BATTERY GROUND STUD
FC3BR	EYELET (PAIR) - RIGHT HAND LEG / TRANSMISSION TUNNEL, LEFT HAND SIDE

CONTROL MODULE PIN OUT INFORMATION (FOLD OUT PAGE)



The following symbols are used to represent values for Control Module Pin Out data:

I	Input	D	Serial and encoded communications	B+	Battery voltage	KHz	Frequency x 1000
O	Output	C	CAN (Network)	V	Voltage (DC)	MS	Milliseconds
SG	Signal Ground	S	SCP Network	Hz	Frequency	MV	Millivolts

CAUTION: The information on this data page is furnished to aid the user in understanding circuit operation. THIS INFORMATION SHOULD BE USED FOR REFERENCE ONLY.

NOTE: The values listed are approximately those that can be expected at the control module connector pins with all circuit connections made and all components connected and fitted. "Active" means a load is applied or a switch is ON; "Inactive" means a load is not applied or a switch is OFF.

REFER TO THE FRONT OF THE BOOK FOR ILLUSTRATIONS DETAILING THE LOCATION AND IDENTIFICATION OF COMPONENTS, RELAYS, CONNECTORS, HARNESSES, GROUNDS, VEHICLE CONTROL MODULES AND CONTROL MODULE PINS.

CONTROL MODULE PIN OUT INFORMATION

BODY PROCESSOR MODULE

Pin	Description	Active	Inactive
I FC14-7	NEUTRAL SWITCH STATUS	GROUND (N)	B+ (P, R, D, 4, 3, 2)
D FC14-39	SECURITY ACKNOWLEDGE	ENCODED COMMUNICATIONS	
I FC14-41	STARTER ENGAGE REQUEST	GROUND (CRANKING)	B+
O FC14-73	STARTER RELAY ACTIVATE	GROUND (CRANKING)	B-
I FC14-80	BATTERY SUPPLY VOLTAGE	B+	B+
D FC14-92	ENCODED COMMUNICATIONS		

DUAL LINEAR SWITCH

Pin	Description	Active	Inactive
I FC100-2	TCM / DUAL LINEAR SWITCH COMMON GROUND SUPPLY	GROUND	
O FC100-4	NEUTRAL SWITCH STATUS	GROUND (N)	B+ (P, R, D, 4, 3, 2)
O FC100-5	PARK / NEUTRAL CONFIRMATION	B- (P, N)	GROUND (R, D, 4, 3, 2)

ENGINE CONTROL MODULE

Pin	Description	Active	Inactive
D EM10-6	OK TO START - ENCODED COMMUNICATIONS		
I EM10-15	PARK / NEUTRAL CONFIRMATION	B+ (P, N)	GROUND (R,D,4,3,2)
D EM10-17	SECURITY ACKNOWLEDGE	ENCODED COMMUNICATIONS	
I EM11-6	ENGINE CRANK	GROUND (CRANKING)	B+

KEY TRANSPONDER MODULE

Pin	Description	Active	Inactive
D FC22-9	GLASS BREAKAGE / OK TO START (ENCODED COMMUNICATION)		
D FC22-16	OK TO START (ENCODED COMMUNICATION)		
D FC22-17	SECURITY ACKNOWLEDGE (ENCODED COMMUNICATION)		

Fig. 03.2

COMPONENTS

Component	Connector / Type / Color	Location / Access
BATTERY	BT66 / EYELET BT67 / EYELET	TRUNK, RIGHT HAND SIDE
BODY PROCESSOR MODULE	FC14 / 104-WAY AMP EEEC / GREY	PASSENGER SIDE FASCIA / AIRBAG BRACKET
DUAL LINEAR SWITCH	FC100 / 12-WAY MULTILOCK 070 / GREY	LEFT HAND SIDE OF GEAR SELECTOR / CENTER CONSOLE
ENGINE CONTROL MODULE	EM10 / 28-WAY MULTILOCK 040 / GREY EM11 / 16-WAY MULTILOCK 040 / GREY EM12 / 22-WAY MULTILOCK 040 / GREY EM13 / 34-WAY MULTILOCK 040 / GREY EM14 / 12-WAY MULTILOCK 47 / WHITE EM15 / 22-WAY MULTILOCK 47 / WHITE	ENGINE COMPARTMENT / CONTROL MODULE ENCLOSURE
GENERATOR	AN1 / EYELET AN2 / EYELET ST11 / EYELET	ENGINE COMPARTMENT / RIGHT FRONT
HIGH POWER PROTECTION MODULE	BT60 / EYELET BT61 / EYELET BT62 / EYELET BT63 / EYELET	TRUNK / ADJACENT TO BATTERY
IGNITION SWITCH (KEY-IN SWITCH)	FC4 / 8-WAY MULTILOCK 070 / WHITE	STEERING COLUMN
KEY TRANSPONDER MODULE	FC22 / 20-WAY MULTILOCK 040 / GREEN	ADJACENT TO DRIVER SIDE FUSE BOX
REGULATOR (GENERATOR)	PI50 / 3-WAY SUMITOMO 0902 / BLACK	ENGINE COMPARTMENT / GENERATOR
STARTER MOTOR	ST2 / EYELET ST3 / EYELET ST10 / EYELET	ENGINE BLOCK
SUPPRESSION MODULE	AN3 / 2-WAY ECONOSEAL III LC / RED	REARWARD OF RIGHT FRONT HEADLAMP

RELAYS

Relay	Color / Stripe	Connector / Color	Location / Access
STARTER RELAY	BROWN	EM50 / BROWN	RH ENCLOSURE RELAYS

HARNESS-TO-HARNESS CONNECTORS

Connector	Type / Color	Location / Access
BT80	EYELET	ENGINE COMPARTMENT / FALSE BULKHEAD, RIGHT HAND SIDE
EM1	20-WAY MULTILOCK 070 / WHITE	ENGINE COMPARTMENT / ADJACENT TO RIGHT HAND ENCLOSURE
EM2	18-WAY MULTILOCK 070 / YELLOW	ENGINE COMPARTMENT / ADJACENT TO RIGHT HAND ENCLOSURE
EM3	14-WAY MULTILOCK 070 / GREY	ENGINE COMPARTMENT / ADJACENT TO RIGHT HAND ENCLOSURE
EM60	2-WAY ECONOSEAL III HC / BLACK	ENGINE COMPARTMENT / BEHIND LEFT INNER FENDER HEAT SHIELD
PI1	57-WAY SUMITOMO / BLACK	ENGINE COMPARTMENT / BRACKET ON TOP OF TRANSMISSION
ST1	EYELET	ENGINE COMPARTMENT / FALSE BULKHEAD, RIGHT HAND SIDE

GROUNDS

Ground	Location / Type
BT88	BATTERY GROUND STUD
EM1A1	EYELET (PAIR) - LEFT HAND LEG / ENGINE COMPARTMENT, RIGHT HAND ENCLOSURE
EM2A1	EYELET (PAIR) - LEFT HAND LEG / ENGINE COMPARTMENT, LEFT HAND ENCLOSURE

CONTROL MODULE PIN OUT INFORMATION (FOLD OUT PAGE)



The following symbols are used to represent values for Control Module Pin Out data:

I	Input	D	Serial and encoded communications	B+	Battery voltage	KHz	Frequency x 1000
O	Output	C	CAN (Network)	V	Voltage (DC)	MS	Milliseconds
SG	Signal Ground	S	SCP Network	Hz	Frequency	MV	Millivolts

CAUTION: The information on this data page is furnished to aid the user in understanding circuit operation. THIS INFORMATION SHOULD BE USED FOR REFERENCE ONLY.

NOTE: The values listed are approximately those that can be expected at the control module connector pins with all circuit connections made and all components connected and fitted. "Active" means a load is applied or a switch is ON; "Inactive" means a load is not applied or a switch is OFF.

REFER TO THE FRONT OF THE BOOK FOR ILLUSTRATIONS DETAILING THE LOCATION AND IDENTIFICATION OF COMPONENTS, RELAYS, CONNECTORS, HARNESES, GROUNDS, VEHICLE CONTROL MODULES AND CONTROL MODULE PINS.

CONTROL MODULE PIN OUT INFORMATION

ENGINE CONTROL MODULE

Pin	Description	Active	Inactive
I EM10-1	IGNITION SWITCHED POWER SUPPLY	B+	0 V
I EM10-5	IGNITION SWITCHED POWER SUPPLY	B+	B+
D EM10-6	OK TO START - ENCODED COMMUNICATIONS		
I EM10-9	BATTERY POWER SUPPLY	B+	B+
I EM10-10	BRAKE SWITCH	GROUND	B+
D EM10-12	SERIAL COMMUNICATIONS		
D EM10-13	SERIAL COMMUNICATIONS		
I EM10-14	PARKING BRAKE SWITCH	GROUND (APPLIED)	B+
I EM10-15	PARK / NEUTRAL CONFIRMATION	B+ (P, N)	GROUND (R,D,4,3,2)
O EM10-16	EMS CONTROLLED RELAY ACTIVATE	GROUND	B-
D EM10-17	SECURITY ACKNOWLEDGE	ENCODED COMMUNICATIONS	
O EM10-20	IATS / ECTS / TPS / MECHANICAL GUARD POSITION / PEDAL POSITION COMMON REFERENCE GROUND	GROUND	GROUND
O EM10-21	MECHANICAL GUARD POSITION / PEDAL POSITION / TPS COMMON REFERENCE VOLTAGE	5 V	5 V
I EM10-22	GROUND	GROUND	GROUND
I EM10-23	GROUND	GROUND	GROUND
C EM10-25	CAN NETWORK	15 - 1500 Hz	
C EM10-26	CAN NETWORK	15 - 1500 Hz	
C EM10-27	CAN NETWORK	15 - 1500 Hz	
C EM10-28	CAN NETWORK	15 - 1500 Hz	
D EM11-3	ECM PROGRAMMING	B+	B+
I EM11-6	ENGINE CRANK	GROUND (CRANKING)	B+
I EM11-7	FUEL TANK PRESSURE SENSOR FEEDBACK	4.9 V = LOW PRESSURE, 0.2 V = HIGH PRESSURE	
O EM11-8	MECHANICAL GUARD POSITION / PEDAL POSITION / TPS COMMON REFERENCE VOLTAGE	5 V	5 V
I EM11-9	ECT FEEDBACK	0.41 V @ 195°F (DECREASING WITH TEMPERATURE)	
I EM11-10	TPS FEEDBACK	0.5 V = IDLE; 4.75 V = WOT	
I EM11-11	TPS FEEDBACK	0.5 V = IDLE; 4.75 V = WOT	
O EM11-12	IATS / ECTS / TPS / MECHANICAL GUARD POSITION / PEDAL POSITION COMMON REFERENCE GROUND	GROUND	GROUND
I EM11-13	MECHANICAL GUARD POSITION FEEDBACK	0.5 V = IDLE; 4.75 V = WOT	
SG EM11-14	MECHANICAL GUARD POSITION / PEDAL POSITION / TPS SHIELD	GROUND	GROUND
I EM11-15	PEDAL POSITION FEEDBACK	0.5 V = IDLE; 4.75 V = WOT	
I EM11-16	PEDAL POSITION FEEDBACK	0.5 V = IDLE; 4.75 V = WOT	
I EM12-12	IATS FEEDBACK	0.98 V @ 10°C, DECREASING WITH TEMPERATURE	
I EM12-13	MAFS FEEDBACK	1.2 V @ IDLE, INCREASING WITH RPM INCREASE	
I EM12-14	UPSTREAM 'B' BANK HO2S	0.1 - 0.9 V @ IDLE (SWING)	
I EM12-15	UPSTREAM 'A' BANK HO2S	0.1 - 0.9 V @ IDLE (SWING)	
I EM12-16	DOWNSTREAM 'B' BANK O2S	0.1 - 0.9 V @ IDLE (SWING)	
I EM12-17	DOWNSTREAM 'A' BANK O2S	0.1 - 0.9 V @ IDLE (SWING)	
O EM12-18	MAFS REFERENCE GROUND	GROUND	GROUND
O EM12-19	MAFS REFERENCE GROUND	GROUND	GROUND
SG EM12-22	O2S / HO2S COMMON SHIELD	GROUND	GROUND
D EM13-2	ECM PROGRAMMING		
O EM13-4	CANISTER CLOSE VALVE ACTIVATE	GROUND	B+
O EM13-11	VACUUM SWITCHING VALVE #3 ACTIVATE	GROUND	B+
O EM13-12	VACUUM SWITCHING VALVE #1 ACTIVATE	GROUND	B+
O EM13-13	VACUUM SWITCHING VALVE #2 ACTIVATE	GROUND	B+
O EM13-14	THROTTLE MOTOR POWER RELAY ACTIVATE	GROUND	B+
I EM13-17	'B' BANK KNOCK SENSOR FEEDBACK	0 KHz = NO KNOCK, 2 - 20 KHz = KNOCK	B-
I EM13-18	'A' BANK KNOCK SENSOR FEEDBACK	0 KHz = NO KNOCK, 2 - 20 KHz = KNOCK	
I EM13-19	CKPS SIGNAL	5 V @ 1000 RPM = 566 Hz; 2000 RPM = 1132 Hz	
I EM13-20	CMPS SIGNAL	5 Hz @ IDLE	
I EM13-27	CMPS / CKPS / KNOCK SENSORS COMMON SHIELD	GROUND	GROUND
I EM13-28	CKPS SIGNAL	5 V @ 1000 RPM = 566 Hz; 2000 RPM = 1132 Hz	
SG EM13-29	CMPS SIGNAL GROUND	GROUND	GROUND
I EM14-1	THROTTLE MOTOR POWER SUPPLY	B+	GROUND
I EM14-2	THROTTLE MOTOR POWER SUPPLY	B+	GROUND
I EM14-3	IGNITION SWITCHED POWER SUPPLY	B+	GROUND
I EM14-4	GROUND	GROUND	GROUND
O EM14-5	THROTTLE MOTOR POWER SUPPLY	B+	GROUND
O EM14-6	THROTTLE MOTOR POWER SUPPLY	B+	GROUND
I EM14-7	GROUND	GROUND	GROUND
I EM14-8	GROUND	GROUND	GROUND
I EM14-9	GROUND	GROUND	GROUND
I EM14-10	GROUND	GROUND	GROUND
O EM14-11	THROTTLE MOTOR POWER SUPPLY	GROUND	GROUND
O EM14-12	THROTTLE MOTOR POWER SUPPLY	B-	GROUND
O EM15-1	UPSTREAM 'B' BANK HO2S HEATER GROUND	GROUND	GROUND
O EM15-2	UPSTREAM 'A' BANK HO2S HEATER GROUND	GROUND	GROUND
O EM15-3	EVAP VALVE ACTIVATE	GROUND (VALVE OPEN)	B+
O EM15-8	VARIABLE VALVE TIMING SOLENOID 'B' BANK	GROUND	B+
O EM15-9	VARIABLE VALVE TIMING SOLENOID 'A' BANK	GROUND	B+
I EM15-11	GROUND	GROUND	GROUND
I EM15-12	GROUND	GROUND	GROUND
I EM15-22	GROUND	GROUND	GROUND

NOTE: REFER TO THE APPENDIX AT THE REAR OF THIS BOOK FOR CAN AND SCP NETWORK MESSAGES.

The following symbols are used to represent values for Control Module Pin Out data:

I	Input	D	Serial and encoded communications	B+	Battery voltage	KHz	Frequency x 1000
O	Output	C	CAN (Network)	V	Voltage (DC)	MS	Milliseconds
SG	Signal Ground	S	SCP Network	Hz	Frequency	MV	Millivolts

CAUTION: The information on this data page is furnished to aid the user in understanding circuit operation. THIS INFORMATION SHOULD BE USED FOR REFERENCE ONLY.

NOTE: The values listed are approximately those that can be expected at the control module connector pins with all circuit connections made and all components connected and fitted. "Active" means a load is applied or a switch is ON; "Inactive" means a load is not applied or a switch is OFF.

Fig. 04.1

COMPONENTS

Component	Connector / Type / Color	Location / Access
BRAKE SWITCH	AC24 / 4-WAY MULTILOCK 070 / WHITE	TOP OF BRAKE PEDAL
CCV: CANISTER CLOSE VALVE	LF52 / 2-WAY YAZAKI 090 / BLACK	LH FRONT QUARTER / REARWARD OF ROAD WHEEL
CKPS: CRANKSHAFT POSITION SENSOR	PI17 / 3-WAY ECONOSEAL III LC / BLACK	ENGINE / REAR OF BED PLATE
CMPS: CAMSHAFT POSITION SENSOR	PI15 / 2-WAY ECONOSEAL III LC / BLACK	'B' BANK CYLINDER HEAD, REAR
ECM AND TCM COOLING FAN	EM64 / 2-WAY MULTILOCK 070 / WHITE	ENGINE COMPARTMENT / CONTROL MODULE ENCLOSURE
ECTS: ENGINE COOLANT TEMPERATURE SENSOR	PI4 / 2-WAY ECONOSEAL E J2 / GREY	ENGINE COMPARTMENT / REAR OF ENGINE TOP HOSE
ENGINE CONTROL MODULE	EM10 / 28-WAY MULTILOCK 040 / GREY EM11 / 16-WAY MULTILOCK 040 / GREY EM12 / 22-WAY MULTILOCK 040 / GREY EM13 / 34-WAY MULTILOCK 040 / GREY EM14 / 12-WAY MULTILOCK 47 / WHITE EM15 / 22-WAY MULTILOCK 47 / WHITE	ENGINE COMPARTMENT / CONTROL MODULE ENCLOSURE
EVAPP: EVAPORATIVE EMISSION CONTROL VALVE	LF58 / 2-WAY ECONOSEAL J2 / BLACK	LH FRONT QUARTER / REARWARD OF ROAD WHEEL
FTP SENSOR: FUEL TANK PRESSURE SENSOR	BT5 / 3-WAY ECONOSEAL III LC / BLACK	TRUNK / FUEL TANK EVAPORATIVE FLANGE
HO2S: HEATED OXYGEN SENSOR - A UPSTREAM	EM21 / 4-WAY SUMITOMO 090 II / GREY	'A' BANK CATALYTIC CONVERTER
HO2S: HEATED OXYGEN SENSOR - B UPSTREAM	EM23 / 4-WAY SUMITOMO 090 II / GREY	'B' BANK CATALYTIC CONVERTER
KS: KNOCK SENSOR - A	PI26 / 2-WAY ECONOSEAL III LC / BLACK	ENGINE VEE / UNDER INTAKE MANIFOLD
KS: KNOCK SENSOR - B	PI27 / 2-WAY ECONOSEAL III LC / BLACK	ENGINE VEE / UNDER INTAKE MANIFOLD
MAFS: MASS AIR FLOW SENSOR	PI35 / 5-WAY YAZAKI 0902 / BLACK	ENGINE COMPARTMENT / REARWARD OF AIR CLEANER
O2S: OXYGEN SENSOR - A DOWNSTREAM	EM22 / 2-WAY SUMITOMO 090 A TYPE / GREY	'A' BANK CATALYTIC CONVERTER
O2S: OXYGEN SENSOR - B DOWNSTREAM	EM24 / 2-WAY SUMITOMO 090 A TYPE / GREY	'B' BANK CATALYTIC CONVERTER
PARKING BRAKE SWITCH	FC19 / LUCAR RIGHT ANGLE	BELOW PARKING BRAKE LEVER
PEDAL POSITION AND MECHANICAL GUARD SENSORS	PI42 / 5-WAY YAZAKI 0902 / BLACK	ENGINE COMPARTMENT / THROTTLE ASSEMBLY
THROTTLE MOTOR	PI33 / 2-WAY TWIN CLIP / BLACK	ENGINE COMPARTMENT / THROTTLE ASSEMBLY
THROTTLE POSITION SENSOR	PI6 / 4-WAY SUMITOMO TS090 / BLACK	ENGINE COMPARTMENT / THROTTLE ASSEMBLY
VACUUM SWITCHING VALVE - 1	EL2 / 2-WAY SUMITOMO 090 DC INHIBIT 1 / BLUE	BEHIND RIGHT HAND WHEEL ARCH LINER
VACUUM SWITCHING VALVE - 2	EL3 / 2-WAY SUMITOMO 090 DC INHIBIT 1 / BROWN	BEHIND RIGHT HAND WHEEL ARCH LINER
VACUUM SWITCHING VALVE - 3	EL4 / 2-WAY YAZAKI 090 / GREY	BEHIND RIGHT HAND WHEEL ARCH LINER
VVT SOLENOID VALVE: VARIABLE VALVE TIMING SOLENOID VALVE - A	PI31 / 2-WAY AMP JUNIOR POWER TIMER / BLACK	ENGINE COMPARTMENT / 'A' BANK CYLINDER HEAD, FRONT
VVT SOLENOID VALVE: VARIABLE VALVE TIMING SOLENOID VALVE - B	PI32 / 2-WAY AMP JUNIOR POWER TIMER / BLACK	ENGINE COMPARTMENT / 'B' BANK CYLINDER HEAD, FRONT

RELAYS

Relay	Color / Stripe	Connector / Color	Location / Access
THROTTLE MOTOR POWER RELAY	BROWN	EM16 / BROWN	CONTROL MODULE ENCLOSURE RELAYS

HARNESS-TO-HARNESS CONNECTORS

Connector	Type / Color	Location / Access
AC13	20-WAY MULTILOCK 070 / YELLOW	FASCIA BOTTOM CONNECTOR MOUNTING BRACKET / RIGHT HAND SIDE
BT2	20-WAY MULTILOCK 070 / WHITE	TRUNK / ABOVE RIGHT HAND REAR WHEEL ARCH
EL1	6-WAY ECONOSEAL III LC / BLACK	ENGINE COMPARTMENT / RIGHT HAND ENCLOSURE
EM1	20-WAY MULTILOCK 070 / WHITE	ENGINE COMPARTMENT / ADJACENT TO RIGHT HAND ENCLOSURE
LF3	13-WAY ECONOSEAL III LC / WHITE	ENGINE COMPARTMENT / LEFT HAND ENCLOSURE
LF40	13-WAY ECONOSEAL III LC / BLACK	ENGINE COMPARTMENT / LEFT HAND ENCLOSURE
PI1	57-WAY SUMITOMO / BLACK	ENGINE COMPARTMENT / BRACKET ON TOP OF TRANSMISSION
PI2	13-WAY ECONOSEAL III LC / BLACK	ENGINE COMPARTMENT / BRACKET ON TOP OF TRANSMISSION
RH1	20-WAY MULTILOCK 070 / GREY	BEHIND GLOVE BOX

GROUNDS

Ground	Location / Type
EM1AL	EYELET (PAIR) - LEFT HAND LEG / ENGINE COMPARTMENT, RIGHT HAND ENCLOSURE
EM1AR	EYELET (PAIR) - RIGHT HAND LEG / ENGINE COMPARTMENT, RIGHT HAND ENCLOSURE
EM1BR	EYELET (PAIR) - RIGHT HAND LEG / ENGINE COMPARTMENT, RIGHT HAND ENCLOSURE
EM2AL	EYELET (PAIR) - LEFT HAND LEG / ENGINE COMPARTMENT, LEFT HAND ENCLOSURE
EM2AR	EYELET (PAIR) - RIGHT HAND LEG / ENGINE COMPARTMENT, LEFT HAND ENCLOSURE
EM2BR	EYELET (PAIR) - RIGHT HAND LEG / ENGINE COMPARTMENT, LEFT HAND ENCLOSURE

CONTROL MODULE PIN OUT INFORMATION (FOLD OUT PAGE)



REFER TO THE FRONT OF THE BOOK FOR ILLUSTRATIONS DETAILING THE LOCATION AND IDENTIFICATION OF COMPONENTS, RELAYS, CONNECTORS, HARNESSES, GROUNDS, VEHICLE CONTROL MODULES AND CONTROL MODULE PINS.

CONTROL MODULE PIN OUT INFORMATION

ENGINE CONTROL MODULE

Pin	Description	Active	Inactive
I	EM10-1	IGNITION SWITCHED POWER SUPPLY	B+
I	EM10-5	IGNITION SWITCHED POWER SUPPLY	B+
D	EM10-6	OK TO START - ENCODED COMMUNICATIONS	
I	EM10-7	BRAKE SWITCH - NOT USED	
I	EM10-9	BATTERY POWER SUPPLY	B+
I	EM10-10	BRAKE SWITCH	B-
D	EM10-12	SERIAL COMMUNICATIONS	
D	EM10-13	SERIAL COMMUNICATIONS	
I	EM10-14	PARKING BRAKE SWITCH	
I	EM10-15	PARK / NEUTRAL CONFIRMATION	GROUND (APPLIED) B+ (P, N)
O	EM10-16	EMS CONTROLLED RELAY ACTIVATE	GROUND
D	EM10-17	SECURITY ACKNOWLEDGE	ENCODED COMMUNICATIONS
O	EM10-20	IATS / ECTS / TPS / MECHANICAL GUARD POSITION / PEDAL POSITION COMMON REFERENCE GROUND	GROUND
O	EM10-21	MECHANICAL GUARD POSITION / PEDAL POSITION / TPS COMMON REFERENCE VOLTAGE	5 V
I	EM10-22	GROUND	GROUND
I	EM10-23	GROUND	GROUND
C	EM10-25	CAN NETWORK	15 - 1500 Hz
C	EM10-26	CAN NETWORK	15 - 1500 Hz
C	EM10-27	CAN NETWORK	15 - 1500 Hz
C	EM10-28	CAN NETWORK	15 - 1500 Hz
D	EM11-3	ECM PROGRAMMING	B+
I	EM11-6	ENGINE CRANK	GROUND (CRANKING)
I	EM11-7	NOT USED	
O	EM11-8	MECHANICAL GUARD POSITION / PEDAL POSITION / TPS COMMON REFERENCE VOLTAGE	5 V
I	EM11-9	ECT FEEDBACK	0.41 V @ 195°F (DECREASING WITH TEMPERATURE)
I	EM11-10	TPS FEEDBACK	0.5 V = IDLE; 4.75 V = WOT
I	EM11-11	TPS FEEDBACK	0.5 V = IDLE; 4.75 V = WOT
O	EM11-12	IATS / ECTS / TPS / MECHANICAL GUARD POSITION / PEDAL POSITION COMMON REFERENCE GROUND	GROUND
I	EM11-13	MECHANICAL GUARD POSITION FEEDBACK	0.5 V = IDLE; 4.75 V = WOT
SG	EM11-14	MECHANICAL GUARD POSITION / PEDAL POSITION / TPS SHIELD	GROUND
I	EM11-15	PEDAL POSITION FEEDBACK	0.5 V = IDLE; 4.75 V = WOT
I	EM11-16	PEDAL POSITION FEEDBACK	0.5 V = IDLE; 4.75 V = WOT
I	EM12-12	IATS FEEDBACK	0.98 V @ 10°C, DECREASING WITH TEMPERATURE
I	EM12-13	MAFS FEEDBACK	1.2 V @ IDLE, INCREASING WITH RPM INCREASE
I	EM12-14	'B' BANK HO2S	0.1 - 0.9 V @ IDLE (SWING)
I	EM12-15	'A' BANK HO2S	0.1 - 0.9 V @ IDLE (SWING)
I	EM12-16	NOT USED	
I	EM12-17	NOT USED	
O	EM12-18	MAFS REFERENCE GROUND	GROUND
O	EM12-19	MAFS REFERENCE GROUND	GROUND
SG	EM12-22	HO2S COMMON SHIELD	GROUND
D	EM13-2	ECM PROGRAMMING	
O	EM13-4	NOT USED	
O	EM13-11	VACUUM SWITCHING VALVE #3 ACTIVATE	GROUND
O	EM13-12	VACUUM SWITCHING VALVE #1 ACTIVATE	GROUND
O	EM13-13	VACUUM SWITCHING VALVE #2 ACTIVATE	GROUND
O	EM13-14	THROTTLE MOTOR POWER RELAY ACTIVATE	GROUND
I	EM13-17	'B' BANK KNOCK SENSOR FEEDBACK	0 KHz = NO KNOCK, 2 - 20 KHz = KNOCK
I	EM13-18	'A' BANK KNOCK SENSOR FEEDBACK	0 KHz = NO KNOCK, 2 - 20 KHz = KNOCK
I	EM13-19	CKPS SIGNAL	5 V @ 1000 RPM = 566 Hz; 2000 RPM = 1132 Hz
I	EM13-20	CMPS SIGNAL	5 Hz @ IDLE
I	EM13-27	CMPS / CKPS / KNOCK SENSORS COMMON SHIELD	GROUND
I	EM13-28	CKPS SIGNAL	5 V @ 1000 RPM = 566 Hz; 2000 RPM = 1132 Hz
SG	EM13-29	CMPS SIGNAL GROUND	GROUND
I	EM14-1	THROTTLE MOTOR POWER SUPPLY	B+
I	EM14-2	THROTTLE MOTOR POWER SUPPLY	B+
I	EM14-3	IGNITION SWITCHED POWER SUPPLY	B+
I	EM14-4	GROUND	GROUND
O	EM14-5	THROTTLE MOTOR POWER SUPPLY	GROUND
O	EM14-6	THROTTLE MOTOR POWER SUPPLY	B+
I	EM14-7	GROUND	GROUND
I	EM14-8	GROUND	GROUND
I	EM14-9	GROUND	GROUND
I	EM14-10	GROUND	GROUND
O	EM14-11	THROTTLE MOTOR POWER SUPPLY	GROUND
O	EM14-12	THROTTLE MOTOR POWER SUPPLY	B+
O	EM15-1	UPSTREAM 'B' BANK HO2S HEATER GROUND	GROUND
O	EM15-2	UPSTREAM 'A' BANK HO2S HEATER GROUND	GROUND
O	EM15-3	EVAP VALVE ACTIVATE	GROUND (VALVE OPEN)
O	EM15-8	VARIABLE VALVE TIMING SOLENOID 'B' BANK	GROUND
O	EM15-9	VARIABLE VALVE TIMING SOLENOID 'A' BANK	GROUND
I	EM15-11	GROUND	GROUND
I	EM15-12	GROUND	GROUND
I	EM15-22	GROUND	GROUND

NOTE: REFER TO THE APPENDIX AT THE REAR OF THIS BOOK FOR CAN AND SCP NETWORK MESSAGES.

The following symbols are used to represent values for Control Module Pin Out data:

I	Input	D	Serial and encoded communications	B+	Battery voltage	KHz	Frequency x 1000
O	Output	C	CAN (Network)	B-	Voltage (DC)	MS	Milliseconds
SG	Signal Ground	S	SCP Network	Hz	Frequency	MV	Millivolts

CAUTION: The information on this data page is furnished to aid the user in understanding circuit operation. THIS INFORMATION SHOULD BE USED FOR REFERENCE ONLY.

NOTE: The values listed are approximately those that can be expected at the control module connector pins with all circuit connections made and all components connected and fitted. "Active" means a load is applied or a switch is ON; "Inactive" means a load is not applied or a switch is OFF.

Fig. 04.2

COMPONENTS

Component	Connector / Type / Color	Location / Access
BRAKE SWITCH	AC24 / 4-WAY MULTILOCK 070 / WHITE	TOP OF BRAKE PEDAL
CKPS: CRANKSHAFT POSITION SENSOR	PI17 / 3-WAY ECONOSEAL III LC / BLACK	ENGINE / REAR OF BED PLATE
CMPS: CAMSHAFT POSITION SENSOR	PI15 / 2-WAY ECONOSEAL III HC / BLACK	'B' BANK CYLINDER HEAD, REAR
ECM AND TCM COOLING FAN	EM64 / 2-WAY MULTILOCK 070 / WHITE	ENGINE COMPARTMENT / CONTROL MODULE ENCLOSURE
ECTS: ENGINE COOLANT TEMPERATURE SENSOR	PI4 / 2-WAY ECONOSEAL E J2 / GREY	ENGINE COMPARTMENT / REAR OF ENGINE TOP HOSE
ENGINE CONTROL MODULE	EM10 / 28-WAY MUII TILLOCK 040 / GREY EM11 / 16-WAY MULTILOCK 040 / GREY EM12 / 22-WAY MULTILOCK 040 / GREY EM13 / 34-WAY MULTILOCK 040 / GREY EM14 / 12-WAY MULTILOCK 47 / WHITE EM15 / 22-WAY MULTILOCK 47 / WHITE	ENGINE COMPARTMENT / CONTROL MODULE ENCLOSURE
EVAPP: EVAPORATIVE EMISSION CONTROL VALVE	LF58 / 2-WAY ECONOSEAL J2 / BLACK	LH FRONT QUARTER / REARWARD OF ROAD WHEEL
HO2S: HEATED OXYGEN SENSOR - A UPSTREAM	EM21 / 4-WAY SUMITOMO 090 II / GREY	'A' BANK CATALYTIC CONVERTER
HO2S: HEATED OXYGEN SENSOR - B UPSTREAM	EM23 / 4-WAY SUMITOMO 090 II / GREY	'B' BANK CATALYTIC CONVERTER
KS: KNOCK SENSOR - A	PI28 / 2-WAY ECONOSEAL III LC / BLACK	ENGINE VEE / UNDER INTAKE MANIFOLD
KS: KNOCK SENSOR - B	PI27 / 2-WAY ECONOSEAL III LC / BLACK	ENGINE VEE / UNDER INTAKE MANIFOLD
MAFS: MASS AIR FLOW SENSOR	PI35 / 5-WAY YAZAKI 0902 / BLACK	ENGINE COMPARTMENT / REARWARD OF AIR CLEANER
PARKING BRAKE SWITCH	FC19 / LUCAR RIGHT ANGLE	BELOW PARKING BRAKE LEVER
PEDAL POSITION AND MECHANICAL GUARD SENSORS	PI42 / 5-WAY YAZAKI 0902 / BLACK	ENGINE COMPARTMENT / THROTTLE ASSEMBLY
THROTTLE MOTOR	PI33 / 2-WAY TWIN CLIP / BLACK	ENGINE COMPARTMENT / THROTTLE ASSEMBLY
THROTTLE POSITION SENSOR	PI6 / 4-WAY SUMITOMO TS090 / BLACK	ENGINE COMPARTMENT / THROTTLE ASSEMBLY
VACUUM SWITCHING VALVE - 1	EL2 / 2-WAY SUMITOMO 090 DC INHIBIT 1 / BLUE	BEHIND RIGHT HAND WHEEL ARCH LINER
VACUUM SWITCHING VALVE - 2	EL3 / 2-WAY SUMITOMO 090 DC INHIBIT 1 / BROWN	BEHIND RIGHT HAND WHEEL ARCH LINER
VACUUM SWITCHING VALVE - 3	EL4 / 2-WAY YAZAKI 090 / GREY	BEHIND RIGHT HAND WHEEL ARCH LINER
VVT SOLENOID VALVE: VARIABLE VALVE TIMING SOLENOID VALVE - A	PI31 / 2-WAY AMP JUNIOR POWER TIMER / BLACK	ENGINE COMPARTMENT / 'A' BANK CYLINDER HEAD, FRONT
VVT SOLENOID VALVE: VARIABLE VALVE TIMING SOLENOID VALVE - B	PI32 / 2-WAY AMP JUNIOR POWER TIMER / BLACK	ENGINE COMPARTMENT / 'B' BANK CYLINDER HEAD, FRONT

RELAYS

Relay	Color / Stripe	Connector / Color	Location / Access
THROTTLE MOTOR POWER RELAY	BROWN	EM16 / BROWN	CONTROL MODULE ENCLOSURE RELAYS

HARNESS-TO-HARNESS CONNECTORS

Connector	Type / Color	Location / Access
AC13	20-WAY MULTILOCK 070 / YELLOW	FASCIA BOTTOM CONNECTOR MOUNTING BRACKET / RIGHT HAND SIDE
BT2	20-WAY MULTILOCK 070 / WHITE	TRUNK / ABOVE RIGHT HAND REAR WHEEL ARCH
EL1	6-WAY ECONOSEAL III LC / BLACK	ENGINE COMPARTMENT / RIGHT HAND ENCLOSURE
EM1	20-WAY MULTILOCK 070 / WHITE	ENGINE COMPARTMENT / ADJACENT TO RIGHT HAND ENCLOSURE
LF3	13-WAY ECONOSEAL III LC / WHITE	ENGINE COMPARTMENT / LEFT HAND ENCLOSURE
LF40	13-WAY ECONOSEAL III LC / BLACK	ENGINE COMPARTMENT / LEFT HAND ENCLOSURE
PI1	57-WAY SUMITOMO / BLACK	ENGINE COMPARTMENT / BRACKET ON TOP OF TRANSMISSION
PI2	13-WAY ECONOSEAL III LC / BLACK	ENGINE COMPARTMENT / BRACKET ON TOP OF TRANSMISSION
RH1	20-WAY MULTILOCK 070 / GREY	BEHIND GLOVE BOX

GROUNDS

Ground	Location / Type
EM1AL	EYELET (PAIR) - LEFT HAND LEG / ENGINE COMPARTMENT, RIGHT HAND ENCLOSURE
EM1AR	EYELET (PAIR) - RIGHT HAND LEG / ENGINE COMPARTMENT, RIGHT HAND ENCLOSURE
EM1BR	EYELET (PAIR) - RIGHT HAND LEG / ENGINE COMPARTMENT, RIGHT HAND ENCLOSURE
EM2AL	EYELET (PAIR) - LEFT HAND LEG / ENGINE COMPARTMENT, LEFT HAND ENCLOSURE
EM2AR	EYELET (PAIR) - RIGHT HAND LEG / ENGINE COMPARTMENT, LEFT HAND ENCLOSURE
EM2BR	EYELET (PAIR) - RIGHT HAND LEG / ENGINE COMPARTMENT, LEFT HAND ENCLOSURE

CONTROL MODULE PIN OUT INFORMATION (FOLD OUT PAGE)



REFER TO THE FRONT OF THE BOOK FOR ILLUSTRATIONS DETAILING THE LOCATION AND IDENTIFICATION OF COMPONENTS, RELAYS, CONNECTORS, HARNESSSES, GROUNDS, VEHICLE CONTROL MODULES AND CONTROL MODULE PINS.

CONTROL MODULE PIN OUT INFORMATION

ENGINE CONTROL MODULE

Pin	Description	Active	Inactive
EM10-2	A/CCM LOAD INHIBIT	GROUND	B+
EM10-3	A/CCM ELECTRICAL LOAD SIGNAL	B+	GROUND
EM10-4	A/CCM COMPRESSOR CLUTCH REQUEST	B+	GROUND
EM10-11	BRAKE SWITCH	GROUND	B+
EM11-1	CRUISE CONTROL SET +/-	7.3 V = (+), 8.8 V = (-) B+	
EM11-4	CRUISE CONTROL ON REQUEST	B+	GROUND
EM11-5	CRUISE CONTROL CANCEL / RESUME	7.3 V = RESUME, 8.8 V = CANCEL B+	
EM12-5	4-WAY REFRIGERANT SWITCH HIGH PRESSURE	GROUND @ 20 BAR (290 PSI)	
EM12-6	4-WAY REFRIGERANT SWITCH HIGH PRESSURE	GROUND @ 12 BAR (174 PSI)	
EM12-8	IGNITION MODULE 2 SWITCHING FEEDBACK	23 Hz @ IDLE (5 V)	
EM12-9	IGNITION MODULE 2 SWITCHING FEEDBACK	23 Hz @ IDLE (5 V)	
EM12-10	AIR CONDITIONING COMPRESSOR RELAY ACTIVATE	GROUND	B+
EM13-1	FUEL PUMP RELAY ACTIVATE	GROUND	B+
EM13-3	CRUISE CONTROL ON STATUS LED	GROUND	B+
EM13-9	NOT USED		
EM13-15	SERIES (LOW) SPEED FAN ACTIVATE	GROUND	B+
EM13-16	PARALLEL (HIGH) SPEED FAN ACTIVATE	GROUND	B+
EM13-22	IGNITION COIL RELAY ACTIVATE	GROUND	B+
EM13-23	IGNITION MODULE 1 SWITCHING	5 Hz @ IDLE	B+
EM13-24	IGNITION MODULE 2 SWITCHING	5 Hz @ IDLE	B+
EM13-25	IGNITION MODULE 2 SWITCHING	5 Hz @ IDLE	B+
EM13-26	IGNITION MODULE 1 SWITCHING	5 Hz @ IDLE	B+
EM13-31	IGNITION MODULE 2 SWITCHING	5 Hz @ IDLE	B+
EM13-32	IGNITION MODULE 1 SWITCHING	5 Hz @ IDLE	B+
EM13-33	IGNITION MODULE 1 SWITCHING	5 Hz @ IDLE	B+
EM13-34	IGNITION MODULE 1 SWITCHING	5 Hz @ IDLE	B+
EM15-4	INJECTOR '3B' ACTIVATE	GROUND	B+
EM15-5	INJECTOR '2B' ACTIVATE	GROUND	B+
EM15-6	INJECTOR '4A' ACTIVATE	GROUND	B+
EM15-7	INJECTOR '1A' ACTIVATE	GROUND	B+
EM15-15	INJECTOR '4B' ACTIVATE	GROUND	B+
EM15-16	INJECTOR '3A' ACTIVATE	GROUND	B+
EM15-17	INJECTOR '2A' ACTIVATE	GROUND	B+
EM15-18	INJECTOR '1B' ACTIVATE	GROUND	B+

AIR CONDITIONING CONTROL MODULE

Pin	Description	Active	Inactive
AC1-1	COMPRESSOR CLUTCH STATUS	B+ (ON)	0 V
AC3-1	AIR CONDITIONING ELECTRICAL LOAD SIGNAL	B+	0 V
AC4-7	LOAD INHIBIT	0 V	B+
AC4-9	COMPRESSOR CLUTCH ON REQUEST	B+	0 V
AC4-17	REFRIGERANT 4-WAY PRESSURE SWITCH	0 V (2 - 30 BAR)	B+ (OUT OF ACTIVE RANGE)

The following symbols are used to represent values for Control Module Pin Out data:

I	Input	D	Serial and encoded communications	B+	Battery voltage	KHz	Frequency x 1000
O	Output	C	CAN (Network)	V	Voltage (DC)	MS	Milliseconds
SG	Signal Ground	S	SCP Network	Hz	Frequency	MV	Millivolts

CAUTION: The information on this data page is furnished to aid the user in understanding circuit operation. THIS INFORMATION SHOULD BE USED FOR REFERENCE ONLY.

NOTE: The values listed are approximately those that can be expected at the control module connector pins with all circuit connections made and all components connected and fitted. "Active" means a load is applied or a switch is ON; "Inactive" means a load is not applied or a switch is OFF.

Fig. 04.3

COMPONENTS

Component	Connector / Type / Color	Location / Access
AIR CONDITIONING COMPRESSOR CLUTCH	PI36 / 1-WAY SUMITOMO 090 A-TYPE / BLACK	ENGINE COMPARTMENT / A/C COMPRESSOR
AIR CONDITIONING CONTROL MODULE	AC1 / 26-WAY MULTILOCK 47 / GREY AC2 / 16-WAY MULTILOCK 47 / GREY AC3 / 12-WAY MULTILOCK 47 / GREY AC4 / 22-WAY MULTILOCK 47 / GREY AC24 / 4-WAY MULTILOCK 070 / WHITE FC63 / 10-WAY AMP MOL / NATURAL SW3 / 3-WAY EPC / BLACK AND WHITE	A/C UNIT / RIGHT HAND SIDE
BRAKE CANCEL SWITCH	EM10 / 28-WAY MULTILOCK 040 / GREY	TOP OF BRAKE PEDAL
CRUISE CONTROL ON / OFF SWITCH	EM11 / 16-WAY MULTILOCK 040 / GREY	REARWARD OF GEAR SELECTOR
CRUISE CONTROL SWITCHES (STEERING WHEEL)	EM12 / 22-WAY MULTILOCK 040 / GREY EM13 / 34-WAY MULTILOCK 040 / GREY EM14 / 12-WAY MULTILOCK 47 / WHITE EM15 / 22-WAY MULTILOCK 47 / WHITE	CENTER OF STEERING WHEEL
ENGINE CONTROL MODULE	EM10 / 28-WAY MULTILOCK 040 / GREY EM11 / 16-WAY MULTILOCK 040 / GREY EM12 / 22-WAY MULTILOCK 040 / GREY EM13 / 34-WAY MULTILOCK 040 / GREY EM14 / 12-WAY MULTILOCK 47 / WHITE EM15 / 22-WAY MULTILOCK 47 / WHITE	ENGINE COMPARTMENT / CONTROL MODULE ENCLOSURE
FUEL INJECTOR - 1A	PI7 / 2-WAY AMP JUNIOR POWER TIMER / BLACK	INTAKE MANIFOLD / FUEL RAIL
FUEL INJECTOR - 1B	PI11 / 2-WAY AMP JUNIOR POWER TIMER / BLACK	INTAKE MANIFOLD / FUEL RAIL
FUEL INJECTOR - 2A	PI8 / 2-WAY AMP JUNIOR POWER TIMER / BLACK	INTAKE MANIFOLD / FUEL RAIL
FUEL INJECTOR - 2B	PI12 / 2-WAY AMP JUNIOR POWER TIMER / BLACK	INTAKE MANIFOLD / FUEL RAIL
FUEL INJECTOR - 3A	PI9 / 2-WAY AMP JUNIOR POWER TIMER / BLACK	INTAKE MANIFOLD / FUEL RAIL
FUEL INJECTOR - 3B	PI13 / 2-WAY AMP JUNIOR POWER TIMER / BLACK	INTAKE MANIFOLD / FUEL RAIL
FUEL INJECTOR - 4A	PI10 / 2-WAY AMP JUNIOR POWER TIMER / BLACK	INTAKE MANIFOLD / FUEL RAIL
FUEL INJECTOR - 4B	PI14 / 2-WAY AMP JUNIOR POWER TIMER / BLACK	INTAKE MANIFOLD / FUEL RAIL
FUEL PUMP	DT55 / 4-WAY SUMITOMO DL090 / NATURAL	TRUNK / TOP OF FUEL TANK
FUSE BOX - TRUNK	BT10 / 10-WAY U.T.A. FUSEBOX / NATURAL BT11 / 10-WAY U.T.A. FUSEBOX / BLACK BT12 / 10-WAY U.T.A. FUSEBOX / GREEN BT13 / 10-WAY U.T.A. FUSEBOX / BLUE BT64 / EYELET	TRUNK / ELECTRICAL CARRIER
IGNITION COIL - 1A	PI18 / 2-WAY YAZAKI 090X / BLACK	ENGINE COMPARTMENT / CAMSHAFT COVER
IGNITION COIL - 1B	PI22 / 2-WAY YAZAKI 090X / BLACK	ENGINE COMPARTMENT / CAMSHAFT COVER
IGNITION COIL - 2A	PI19 / 2-WAY YAZAKI 090X / BLACK	ENGINE COMPARTMENT / CAMSHAFT COVER
IGNITION COIL - 2B	PI23 / 2-WAY YAZAKI 090X / BLACK	ENGINE COMPARTMENT / CAMSHAFT COVER
IGNITION COIL - 3A	PI20 / 2-WAY YAZAKI 090X / BLACK	ENGINE COMPARTMENT / CAMSHAFT COVER
IGNITION COIL - 3B	PI24 / 2-WAY YAZAKI 090X / BLACK	ENGINE COMPARTMENT / CAMSHAFT COVER
IGNITION COIL - 4A	PI21 / 2-WAY YAZAKI 090X / BLACK	ENGINE COMPARTMENT / CAMSHAFT COVER
IGNITION COIL - 4B	PI25 / 2-WAY YAZAKI 090X / BLACK	ENGINE COMPARTMENT / CAMSHAFT COVER
IGNITION MODULE - 1	EM27 / 12-WAY IGNITION POWER MODULE / BLACK	ENGINE COMPARTMENT / BULKHEAD, RIGHT HAND SIDE
IGNITION MODULE - 2	EM29 / 12-WAY IGNITION POWER MODULE / BLACK	ENGINE COMPARTMENT / BULKHEAD, LEFT HAND SIDE
RADIATOR FAN CONTROL RELAY MODULE	LF9 / 8-WAY TRW / BLACK	ADJACENT TO LEFT HAND HORN
RADIATOR FAN - LH	LF13 / 2-WAY REINSHAGEN METRI 630 / BLACK	ENGINE COMPARTMENT / FRONT
RADIATOR FAN - RH	LF12 / 2-WAY REINSHAGEN METRI 630 / BLACK	ENGINE COMPARTMENT / FRONT
REFRIGERANT 4-WAY PRESSURE SWITCH	LF57 / 6-WAY ECONOSEAL III LC / BLACK	ENGINE COMPARTMENT / REARWARD OF RADIATOR

RELAYS

Relay	Color / Stripe	Connector / Color	Location / Access
AIR CONDITIONING COMPRESSOR CLUTCH RELAY	BROWN	BUS	LH ENCLOSURE RELAYS
FUEL INJECTION RELAY	BROWN	EM5 / BROWN	CONTROL MODULE ENCLOSURE RELAYS
FUEL PUMP RELAY (#4)	BROWN	BUS	TRUNK FUSE BOX
IGNITION COIL RELAY	BROWN	EM26 / BROWN	CONTROL MODULE ENCLOSURE RELAYS

HARNESS-TO-HARNESS CONNECTORS

Connector	Type / Color	Location / Access
AC12	20-WAY MULTILOCK 070 / WHITE	FASCIA TOP CONNECTOR MOUNTING BRACKET / RIGHT HAND SIDE
AC13	20-WAY MULTILOCK 070 / YELLOW	FASCIA BOTTOM CONNECTOR MOUNTING BRACKET / RIGHT HAND SIDE
BT2	20-WAY MULTILOCK 070 / WHITE	TRUNK / ABOVE RIGHT HAND REAR WHEEL ARCH
EM1	20-WAY MULTILOCK 070 / WHITE	ENGINE COMPARTMENT / ADJACENT TO RIGHT HAND ENCLOSURE
EM2	18-WAY MULTILOCK 070 / YELLOW	ENGINE COMPARTMENT / ADJACENT TO RIGHT HAND ENCLOSURE
EM3	14-WAY MULTILOCK 070 / GREY	ENGINE COMPARTMENT / ADJACENT TO RIGHT HAND ENCLOSURE
LF3	13-WAY ECONOSEAL III LC / WHITE	ENGINE COMPARTMENT / LEFT HAND ENCLOSURE
LF40	13-WAY ECONOSEAL III LC / BLACK	ENGINE COMPARTMENT / LEFT HAND ENCLOSURE
PI1	57-WAY SUMITOMO / BLACK	ENGINE COMPARTMENT / BRACKET ON TOP OF TRANSMISSION
PI2	13-WAY ECONOSEAL III LC / BLACK	ENGINE COMPARTMENT / BRACKET ON TOP OF TRANSMISSION
RH1	20-WAY MULTILOCK 070 / GREY	BEHIND GLOVE BOX
RH2	20-WAY MULTILOCK 070 / WHITE	REAR OF CENTER CONSOLE ASSEMBLY
SC3	12-WAY MULTILOCK 070 / GREY	RIGHT HAND SIDE OF STEERING COLUMN
SW1	12-WAY MULTILOCK 040 / BLACK	INSIDE STEERING COLUMN COWL
SW2	6-WAY JST / WHITE	CENTER OF STEERING WHEEL

GROUNDINGS

Ground	Location / Type
BT2AL	EYELET (PAIR) - LEFT HAND LEG / TRUNK, RIGHT REAR
EM1AR	EYELET (PAIR) - RIGHT HAND LEG / ENGINE COMPARTMENT, RIGHT HAND ENCLOSURE
EM2AR	EYELET (PAIR) - RIGHT HAND LEG / ENGINE COMPARTMENT, LEFT HAND ENCLOSURE
FC3BL	EYELET (PAIR) - LEFT HAND LEG / TRANSMISSION TUNNEL, LEFT HAND SIDE
LF2AL	EYELET (PAIR) - LEFT HAND LEG / ENGINE COMPARTMENT, FORWARD OF LEFT HAND HOOD CATCH
LF2BL	EYELET (PAIR) - LEFT HAND LEG / ENGINE COMPARTMENT, FORWARD OF LEFT HAND HOOD CATCH

CONTROL MODULE PIN OUT INFORMATION (FOLD OUT PAGE)



REFER TO THE FRONT OF THE BOOK FOR ILLUSTRATIONS DETAILING THE LOCATION AND IDENTIFICATION OF COMPONENTS, RELAYS, CONNECTORS, HARNESSES, GROUNDS, VEHICLE CONTROL MODULES AND CONTROL MODULE PINS.

CONTROL MODULE PIN OUT INFORMATION

ENGINE CONTROL MODULE

Pin	Description	Active	Inactive
I EM10-1	IGNITION SWITCHED POWER SUPPLY	B+	0 V
I EM10-5	IGNITION SWITCHED POWER SUPPLY	B+	B-
D EM10-6	OK TO START - ENCODED COMMUNICATIONS		
I EM10-7	BRAKE SWITCH - NOT USED		
I EM10-9	BATTERY POWER SUPPLY	B+	B-
I EM10-10	BRAKE SWITCH	GROUND	B-
D EM10-12	SERIAL COMMUNICATIONS		B-
D EM10-13	SERIAL COMMUNICATIONS		B-
I EM10-14	PARKING BRAKE SWITCH	GROUND (APPLIED)	B+
I EM10-15	PARK / NEUTRAL CONFIRMATION	B+ (P, N)	GROUND (R, D, 4, 3, 2)
O EM10-16	EMS CONTROLLED RELAY ACTIVATE	GROUND	B+
D EM10-17	SECURITY ACKNOWLEDGE	ENCODED COMMUNICATIONS	
O EM10-20	IATS / ECTS / TPS / MECHANICAL GUARD POSITION / PEDAL POSITION COMMON REFERENCE GROUND	GROUND	GROUND
O EM10-21	MECHANICAL GUARD POSITION / PEDAL POSITION / TPS COMMON REFERENCE VOLTAGE	5 V	5 V
I FM10-22	GROUND	GROUND	GROUND
J EM10-23	GROUND	GROUND	GROUND
C EM10-25	CAN NETWORK	15 - 1500 Hz	GROUND
C EM10-26	CAN NETWORK	15 - 1500 Hz	GROUND
C EM10-27	CAN NETWORK	15 - 1500 Hz	GROUND
C EM10-28	CAN NETWORK	15 - 1500 Hz	GROUND
D EM11-3	ECM PROGRAMMING	B+	B+
I EM11-6	ENGINE CRANK	GROUND (CRANKING)	B+
I EM11-7	NOT USED		B+
O EM11-8	MECHANICAL GUARD POSITION / PEDAL POSITION / TPS COMMON REFERENCE VOLTAGE	5 V	5 V
I EM11-9	ECT FEEDBACK	0.41 V @ 195°F (DECREASING WITH TEMPERATURE)	
I FM11-10	TPS FEEDBACK	0.5 V = IDLE; 4.75 V = WOT	
I EM11-11	TPS FEEDBACK	0.5 V = IDLE; 4.75 V = WOT	
O EM11-12	IATS / ECTS / TPS / MECHANICAL GUARD POSITION / PEDAL POSITION COMMON REFERENCE GROUND	GROUND	GROUND
I EM11-13	MECHANICAL GUARD POSITION FEEDBACK	0.5 V = IDLE; 4.75 V = WOT	GROUND
SG EM11-14	MECHANICAL GUARD POSITION / PEDAL POSITION / TPS SHIELD	GROUND	GROUND
I EM11-15	PEDAL POSITION FEEDBACK	0.5 V = IDLE; 4.75 V = WOT	
I EM11-16	PEDAL POSITION FEEDBACK	0.5 V = IDLE; 4.75 V = WOT	
EM12-1	NOT USED		
EM12-2	NOT USED		
EM12-3	NOT USED		
EM12-4	NOT USED		
I EM12-7	IATS 2 FEEDBACK	2.38 V @ 20°C, DECREASING WITH TEMPERATURE	
I EM12-12	IATS FEEDBACK	0.98 V @ 10°C, DECREASING WITH TEMPERATURE	
I EM12-13	MAFS FEEDBACK	1.2 V @ IDLE, INCREASING WITH RPM INCREASE	
I EM12-14	'B' BANK HO2S	0.1 - 0.9 V @ IDLE (SWING)	
I EM12-15	'A' BANK HO2S	0.1 - 0.9 V @ IDLE (SWING)	
I EM12-16	NOT USED		
I EM12-17	NOT USED		
O EM12-18	MAFS REFERENCE GROUND	GROUND	GROUND
O EM12-19	MAFS REFERENCE GROUND	GROUND	GROUND
SG EM12-22	HO2S COMMON SHIELD	GROUND	GROUND
D EM13-2	ECM PROGRAMMING		
O EM13-4	NOT USED		
O EM13-11	VACUUM SWITCHING VALVE #3 ACTIVATE	GROUND	B+
O EM13-12	VACUUM SWITCHING VALVE #1 ACTIVATE	GROUND	B+
O EM13-13	VACUUM SWITCHING VALVE #2 ACTIVATE	GROUND	B+
O EM13-14	THROTTLE MOTOR POWER RELAY ACTIVATE	GROUND	B+
I EM13-17	'B' BANK KNOCK SENSOR FEEDBACK	0 KHz = NO KNOCK, 2 - 20 KHz = KNOCK	
I EM13-18	'A' BANK KNOCK SENSOR FEEDBACK	0 KHz = NO KNOCK, 2 - 20 KHz = KNOCK	
I EM13-19	CKPS SIGNAL	5 V @ 1000 RPM = 566 Hz; 2000 RPM = 1132 Hz	
I EM13-20	CMPS SIGNAL	5 Hz @ IDLE	
I EM13-27	CMPS / CKPS / KNOCK SENSORS COMMON SHIELD	GROUND	GROUND
I EM13-28	CKPS SIGNAL	5 V @ 1000 RPM = 566 Hz; 2000 RPM = 1132 Hz	
SG EM13-29	CMPS SIGNAL GROUND	GROUND	GROUND
I EM14-1	THROTTLE MOTOR POWER SUPPLY	B+	GROUND
I EM14-2	THROTTLE MOTOR POWER SUPPLY	B+	GROUND
I EM14-3	IGNITION SWITCHED POWER SUPPLY	B+	GROUND
I EM14-4	GROUND	GROUND	GROUND
O EM14-5	THROTTLE MOTOR POWER SUPPLY	B+	GROUND
O EM14-6	THROTTLE MOTOR POWER SUPPLY	B+	GROUND
I EM14-7	GROUND	GROUND	GROUND
I EM14-8	GROUND	GROUND	GROUND
I EM14-9	GROUND	GROUND	GROUND
I EM14-10	GROUND	GROUND	GROUND
O EM14-11	THROTTLE MOTOR POWER SUPPLY	GROUND	GROUND
O EM14-12	THROTTLE MOTOR POWER SUPPLY	B+	GROUND
O EM15-1	UPSTREAM 'B' BANK HO2S HEATER GROUND	GROUND	GROUND
O EM15-2	UPSTREAM 'A' BANK HO2S HEATER GROUND	GROUND	GROUND
O EM15-3	EVAP VALVE ACTIVATE	GROUND (VALVE OPEN)	B+
I EM15-11	GROUND	GROUND	GROUND
I EM15-12	GROUND	GROUND	GROUND
I EM15-22	GROUND	GROUND	GROUND

NOTE: REFER TO THE APPENDIX AT THE REAR OF THIS BOOK FOR CAN AND SCP NETWORK MESSAGES.

The following symbols are used to represent values for Control Module Pin Out data:

I Input	D Serial and encoded communications	B+ Battery voltage	KHz Frequency x 1000
O Output	C CAN (Network)	V Voltage (DC)	MS Milliseconds
SG Signal Ground	S SCP Network	Hz Frequency	MV Millivolts

CAUTION: The information on this data page is furnished to aid the user in understanding circuit operation. THIS INFORMATION SHOULD BE USED FOR REFERENCE ONLY.

NOTE: The values listed are approximately those that can be expected at the control module connector pins with all circuit connections made and all components connected and fitted. "Active" means a load is applied or a switch is ON; "Inactive" means a load is not applied or a switch is OFF.

Fig. 04.4

COMPONENTS

Component	Connector / Type / Color	Location / Access
BRAKE SWITCH	AC24 / 4-WAY MULTILOCK 070 / WHITE	TOP OF BRAKE PEDAL
CKPS: CRANKSHAFT POSITION SENSOR	PI17 / 3-WAY ECONOSEAL III LC / BLACK	ENGINE / REAR OF BED PLATE
CMPS: CAMSHAFT POSITION SENSOR	PI15 / 2-WAY ECONOSEAL III HC / BLACK	'B' BANK CYLINDER HEAD, REAR
ECM AND TCM COOLING FAN	EM64 / 2-WAY MULTILOCK 070 / WHITE	ENGINE COMPARTMENT / CONTROL MODULE ENCLOSURE
ECTS: ENGINE COOLANT TEMPERATURE SENSOR	PI4 / 2-WAY ECONOSEAL E J2 / GREY	ENGINE COMPARTMENT / REAR OF ENGINE TOP HOSE
ENGINE CONTROL MODULE	EM10 / 28-WAY MULTILOCK 040 / GREY EM11 / 16-WAY MULTILOCK 040 / GREY EM12 / 22-WAY MULTILOCK 040 / GREY EM13 / 34-WAY MULTILOCK 040 / GREY EM14 / 12-WAY MULTILOCK 47 / WHITE EM15 / 22-WAY MULTILOCK 47 / WHITE	ENGINE COMPARTMENT / CONTROL MODULE ENCLOSURE
EVAPP: EVAPORATIVE EMISSION CONTROL VALVE	LF58 / 2-WAY ECONOSEAL J2 / BLACK	LH FRONT QUARTER / REARWARD OF ROAD WHEEL
HO2S: HEATED OXYGEN SENSOR - A UPSTREAM	EM21 / 4-WAY SUMITOMO 090 II / GREY	'A' BANK CATALYTIC CONVERTER
HO2S: HEATED OXYGEN SENSOR - B UPSTREAM	EM23 / 4-WAY SUMITOMO 090 II / GREY	'B' BANK CATALYTIC CONVERTER
IATS 2: INTAKE AIR TEMPERATURE SENSOR 2	PI41 / 2-WAY AMP JUNIOR POWER TIMER / BLACK	ENGINE COMPARTMENT / 'A' BANK INTERCOOLER / REAR
KS: KNOCK SENSOR - A	PI26 / 2-WAY ECONOSEAL III LC / BLACK	ENGINE VEE / UNDER INTAKE MANIFOLD
KS: KNOCK SENSOR - B	PI27 / 2-WAY ECONOSEAL III LC / BLACK	ENGINE VEE / UNDER INTAKE MANIFOLD
MAFS: MASS AIR FLOW SENSOR	PI35 / 5-WAY YAZAKI 0902 / BLACK	ENGINE COMPARTMENT / REARWARD OF AIR CLEANER
PARKING BRAKE SWITCH	FC19 / LUCAR RIGHT ANGLE	BELOW PARKING BRAKE LEVER
PEDAL POSITION AND MECHANICAL GUARD SENSORS	PI42 / 5-WAY YAZAKI 0902 / BLACK	ENGINE COMPARTMENT / THROTTLE ASSEMBLY
THROTTLE MOTOR	PI33 / 2-WAY TWIN CLIP / BLACK	ENGINE COMPARTMENT / THROTTLE ASSEMBLY
THROTTLE POSITION SENSOR	PI6 / 4-WAY SUMITOMO TS090 / BLACK	ENGINE COMPARTMENT / THROTTLE ASSEMBLY
VACUUM SWITCHING VALVE - 1	EL2 / 2-WAY SUMITOMO 090 DC INHIBIT 1 / BLUE	BEHIND RIGHT HAND WHEEL ARCH LINER
VACUUM SWITCHING VALVE - 2	EL3 / 2-WAY SUMITOMO 090 DC INHIBIT 1 / BROWN	BEHIND RIGHT HAND WHEEL ARCH LINER
VACUUM SWITCHING VALVE - 3	EL4 / 2-WAY YAZAKI 090 / GREY	BEHIND RIGHT HAND WHEEL ARCH LINER

RELAYS

Relay	Color / Stripe	Connector / Color	Location / Access
THROTTLE MOTOR POWER RELAY	BROWN	EM16 / BROWN	CONTROL MODULE ENCLOSURE RELAYS

HARNESS-TO-HARNESS CONNECTORS

Connector	Type / Color	Location / Access
AC13	20-WAY MULTILOCK 070 / YELLOW	FASCIA BOTTOM CONNECTOR MOUNTING BRACKET / RIGHT HAND SIDE
BT2	20-WAY MULTILOCK 070 / WHITE	TRUNK / ABOVE RIGHT HAND REAR WHEEL ARCH
EL1	6-WAY ECONOSEAL III LC / BLACK	ENGINE COMPARTMENT / RIGHT HAND ENCLOSURE
EM1	20-WAY MULTILOCK 070 / WHITE	ENGINE COMPARTMENT / ADJACENT TO RIGHT HAND ENCLOSURE
LF3	13-WAY ECONOSEAL III LC / WHITE	ENGINE COMPARTMENT / LEFT HAND ENCLOSURE
LF40	13-WAY ECONOSEAL III LC / BLACK	ENGINE COMPARTMENT / LEFT HAND ENCLOSURE
PI1	57-WAY SUMITOMO / BLACK	ENGINE COMPARTMENT / BRACKET ON TOP OF TRANSMISSION
PI2	13-WAY ECONOSEAL III LC / BLACK	ENGINE COMPARTMENT / BRACKET ON TOP OF TRANSMISSION
RH1	20-WAY MULTILOCK 070 / GREY	BEHIND GLOVE BOX

GROUNDS

Ground	Location / Type
EM1AL	EYELET (PAIR) - LEFT HAND LEG / ENGINE COMPARTMENT, RIGHT HAND ENCLOSURE
EM1AR	EYELET (PAIR) - RIGHT HAND LEG / ENGINE COMPARTMENT, RIGHT HAND ENCLOSURE
EM1BR	EYELET (PAIR) - RIGHT HAND LEG / ENGINE COMPARTMENT, RIGHT HAND ENCLOSURE
EM2AL	EYELET (PAIR) - LEFT HAND LEG / ENGINE COMPARTMENT, LEFT HAND ENCLOSURE
EM2AR	EYELET (PAIR) - RIGHT HAND LEG / ENGINE COMPARTMENT, LEFT HAND ENCLOSURE
EM2BR	EYELET (PAIR) - RIGHT HAND LEG / ENGINE COMPARTMENT, LEFT HAND ENCLOSURE

CONTROL MODULE PIN OUT INFORMATION (FOLD OUT PAGE)



REFER TO THE FRONT OF THE BOOK FOR ILLUSTRATIONS DETAILING THE LOCATION AND IDENTIFICATION OF COMPONENTS, RELAYS, CONNECTORS, HARNESES, GROUNDS, VEHICLE CONTROL MODULES AND CONTROL MODULE PINS.

CONTROL MODULE PIN OUT INFORMATION

ENGINE CONTROL MODULE

Pin	Description	Active	Inactive
EM10-2	A/CCM LOAD INHIBIT	GROUND	B+
EM10-3	A/CCM ELECTRICAL LOAD SIGNAL	B+	GROUND
EM10-4	A/CCM COMPRESSOR CLUTCH REQUEST	B+	GROUND
EM10-11	BRAKE SWITCH	GROUND	B+
EM11-1	CRUISE CONTROL SET +/-	7.3 V =(+), 8.8 V =(-)B+	
EM11-4	CRUISE CONTROL ON REQUEST	B+	GROUND
EM11-5	CRUISE CONTROL CANCEL / RESUME	7.3 V = RESUME, 8.8 V = CANCEL B+	
EM12-5	4-WAY REFRIGERANT SWITCH HIGH PRESSURE	GROUND @ 20 BAR (290 PSI)	
EM12-6	4-WAY REFRIGERANT SWITCH HIGH PRESSURE	GROUND @ 12 BAR (174 PSI)	
EM12-8	IGNITION MODULE 2 SWITCHING FEEDBACK	23 Hz @ IDLE (5 V)	
EM12-9	IGNITION MODULE 2 SWITCHING FEEDBACK	23 Hz @ IDLE (5 V)	
EM12-10	AIR CONDITIONING COMPRESSOR RELAY ACTIVATE	GROUND	B-
EM13-1	FUEL PUMP RELAY ACTIVATE	GROUND	B+
EM13-3	CRUISE CONTROL ON STATUS LED	GROUND	B+
EM13-9	FUEL PUMP RELAY ACTIVATE	GROUND	B+
EM13-10	INTERCOOLER PUMP RELAY ACTIVATE	GROUND	B+
EM13-15	SERIES (LOW) SPEED FAN ACTIVATE	GROUND	B+
EM13-16	PARALLEL (HIGH) SPEED FAN ACTIVATE	GROUND	B+
EM13-22	IGNITION COIL RELAY ACTIVATE	GROUND	B+
EM13-23	IGNITION MODULE 1 SWITCHING	5 Hz @ IDLE	B+
EM13-24	IGNITION MODULE 2 SWITCHING	5 Hz @ IDLE	B+
EM13-25	IGNITION MODULE 2 SWITCHING	5 Hz @ IDLE	B+
EM13-26	IGNITION MODULE 1 SWITCHING	5 Hz @ IDLE	B+
EM13-31	IGNITION MODULE 2 SWITCHING	5 Hz @ IDLE	B+
EM13-32	IGNITION MODULE 1 SWITCHING	5 Hz @ IDLE	B+
EM13-33	IGNITION MODULE 1 SWITCHING	5 Hz @ IDLE	B+
EM13-34	IGNITION MODULE 1 SWITCHING	5 Hz @ IDLE	B+
EM15-4	INJECTOR '3B' ACTIVATE	GROUND	B+
EM15-5	INJECTOR '2B' ACTIVATE	GROUND	B+
EM15-6	INJECTOR '4A' ACTIVATE	GROUND	B+
EM15-7	INJECTOR '1A' ACTIVATE	GROUND	B+
EM15-15	INJECTOR '4B' ACTIVATE	GROUND	B+
EM15-16	INJECTOR '3A' ACTIVATE	GROUND	B+
EM15-17	INJECTOR '2A' ACTIVATE	GROUND	B+
EM15-18	INJECTOR '1B' ACTIVATE	GROUND	B+

AIR CONDITIONING CONTROL MODULE

Pin	Description	Active	Inactive
AC1-1	COMPRESSOR CLUTCH STATUS	B+ (ON)	0 V
AC3-1	AIR CONDITIONING ELECTRICAL LOAD SIGNAL	B+	0 V
AC4-7	LOAD INHIBIT	0 V	B+
AC4-9	COMPRESSOR CLUTCH ON REQUEST	B+	0 V
AC4-17	REFRIGERANT 4-XZWAY PRESSURE SWITCH	0 V (2 - 30 BAR)	B+ (OUT OF ACTIVE RANGE)

The following symbols are used to represent values for Control Module Pin Out data:

I	Input	D	Serial and encoded communications	B+	Battery voltage	KHz	Frequency x 1000
O	Output	C	CAN (Network)	V	Voltage (DC)	MS	Milliseconds
SG	Signal Ground	S	SCP Network	Hz	Frequency	MV	Millivolts

CAUTION: The information on this data page is furnished to aid the user in understanding circuit operation. THIS INFORMATION SHOULD BE USED FOR REFERENCE ONLY.

NOTE: The values listed are approximately those that can be expected at the control module connector pins with all circuit connections made and all components connected and fitted. "Active" means a load is applied or a switch is ON; "Inactive" means a load is not applied or a switch is OFF.

Fig. 04.5

COMPONENTS

Component	Connector / Type / Color	Location / Access
AIR CONDITIONING COMPRESSOR CLUTCH	PI36 / 1-WAY SUMITOMO 090 A-TYPE / RI ACK	ENGINE COMPARTMENT / A/C COMPRESSOR
AIR CONDITIONING CONTROL MODULE	AC1 / 26-WAY MULTILOCK 47 / GREY AC2 / 16-WAY MULTILOCK 47 / GREY AC3 / 12-WAY MULTILOCK 47 / GREY AC4 / 22-WAY MULTILOCK 47 / GREY AC24 / 4-WAY MULTILOCK 070 / WHITE	A/C UNIT / RIGHT HAND SIDE
BRAKE CANCEL SWITCH	FC63 / 10-WAY AMP MQL / NATURAL	TOP OF BRAKE PEDAL
CRUISE CONTROL ON / OFF SWITCH	SW3 / 3-WAY EPC / BLACK AND WHITE	REARWARD OF GEAR SELECTOR
CRUISE CONTROL SWITCHES (STEERING WHEEL)	EM10 / 28-WAY MULTILOCK 040 / GREY EM11 / 16-WAY MULTILOCK 040 / GREY EM12 / 22-WAY MULTILOCK 040 / GREY EM13 / 34-WAY MULTILOCK 040 / GREY EM14 / 12-WAY MULTILOCK 47 / WHITE EM15 / 22-WAY MULTILOCK 47 / WHITE	CENTER OF STEERING WHEEL
ENGINE CONTROL MODULE		ENGINE COMPARTMENT / CONTROL MODULE ENCLOSURE
FUEL INJECTOR - 1A	IJ3 / 2-WAY AMP JUNIOR POWER TIMER / BLACK	INTAKE MANIFOLD / FUEL RAIL
FUEL INJECTOR - 1B	IJ7 / 2-WAY AMP JUNIOR POWER TIMER / BLACK	INTAKE MANIFOLD / FUEL RAIL
FUEL INJECTOR - 2A	IJ4 / 2-WAY AMP JUNIOR POWER TIMER / BLACK	INTAKE MANIFOLD / FUEL RAIL
FUEL INJECTOR - 2B	IJ8 / 2-WAY AMP JUNIOR POWER TIMER / BLACK	INTAKE MANIFOLD / FUEL RAIL
FUEL INJECTOR - 3A	IJ5 / 2-WAY AMP JUNIOR POWER TIMER / BLACK	INTAKE MANIFOLD / FUEL RAIL
FUEL INJECTOR - 3B	IJ9 / 2-WAY AMP JUNIOR POWER TIMER / BLACK	INTAKE MANIFOLD / FUEL RAIL
FUEL INJECTOR - 4A	IJ6 / 2-WAY AMP JUNIOR POWER TIMER / BLACK	INTAKE MANIFOLD / FUEL RAIL
FUEL INJECTOR - 4B	IJ10 / 2-WAY AMP JUNIOR POWER TIMER / BLACK	INTAKE MANIFOLD / FUEL RAIL
FUEL PUMPS	BT55 / 4-WAY SUMITOMO DL090 / NATURAL	TRUNK / TOP OF FUEL TANK
FUSE BOX - TRUNK	BT10 / 10-WAY U.T.A. FUSEBOX / NATURAL BT11 / 10-WAY U.T.A. FUSEBOX / BLACK BT12 / 10-WAY U.T.A. FUSEBOX / GREEN BT13 / 10-WAY U.T.A. FUSEBOX / BLUE BT64 / EYELET	TRUNK / ELECTRICAL CARRIER
IGNITION COIL - 1A	PI18 / 2-WAY YAZAKI 090X / BLACK	ENGINE COMPARTMENT / CAMSHAFT COVER
IGNITION COIL - 1B	PI22 / 2-WAY YAZAKI 090X / BLACK	ENGINE COMPARTMENT / CAMSHAFT COVER
IGNITION COIL - 2A	PI19 / 2-WAY YAZAKI 090X / BLACK	ENGINE COMPARTMENT / CAMSHAFT COVER
IGNITION COIL - 2B	PI23 / 2-WAY YAZAKI 090X / BLACK	ENGINE COMPARTMENT / CAMSHAFT COVER
IGNITION COIL - 3A	PI20 / 2-WAY YAZAKI 090X / BLACK	ENGINE COMPARTMENT / CAMSHAFT COVER
IGNITION COIL - 3B	PI24 / 2-WAY YAZAKI 090X / BLACK	ENGINE COMPARTMENT / CAMSHAFT COVER
IGNITION COIL - 4A	PI21 / 2-WAY YAZAKI 090X / BLACK	ENGINE COMPARTMENT / CAMSHAFT COVER
IGNITION COIL - 4B	PI25 / 2-WAY YAZAKI 090X / BLACK	ENGINE COMPARTMENT / CAMSHAFT COVER
IGNITION MODULE - 1	EM27 / 12-WAY IGNITION POWER MODULE / BLACK	ENGINE COMPARTMENT / BULKHEAD, RIGHT HAND SIDE
IGNITION MODULE - 2	EM29 / 12-WAY IGNITION POWER MODULE / BLACK	ENGINE COMPARTMENT / BULKHEAD, LEFT HAND SIDE
INTERCOOLER PUMP	EM75 / 2-WAY AUGAT 1.6 / BLACK	ENGINE COMPARTMENT / BELOW AIR CLEANER
RADIATOR FAN CONTROL RELAY MODULE	LF9 / 8-WAY TRW / BLACK	ADJACENT TO LEFT HAND FRONT
RADIATOR FAN - LH	LF13 / 2-WAY REINSHAGEN METRI 630 / BLACK	ENGINE COMPARTMENT / FRONT
RADIATOR FAN - RH	LF12 / 2-WAY REINSHAGEN METRI 630 / BLACK	ENGINE COMPARTMENT / FRONT
REFRIGERANT 4-WAY PRESSURE SWITCH	LF57 / 6-WAY ECONOSEAL III LC / BLACK	ENGINE COMPARTMENT / REARWARD OF RADIATOR

RELAYS

Relay	Color / Stripe	Connector / Color	Location / Access
AIR CONDITIONING COMPRESSOR CLUTCH RELAY	BROWN	BUS	LH ENCLOSURE RELAYS
FUEL INJECTION RELAY	BROWN	EM5 / BROWN	CONTROL MODULE ENCLOSURE RELAYS
FUEL PUMP 1 RELAY (#4)	BROWN	BUS	TRUNK FUSE BOX
FUEL PUMP 2 RELAY	BROWN	BT51 / BROWN	TRUNK RELAYS
IGNITION COIL RELAY	BROWN	EM26 / BROWN	CONTROL MODULE ENCLOSURE RELAYS
INTERCOOLER PUMP RELAY	BROWN	EM31 / BROWN	LHD: CONTROL MODULE ENCLOSURE RELAYS RHD: RH ENCLOSURE RELAYS

HARNESS-TO-HARNESS CONNECTORS

Connector	Type / Color	Location / Access
AC12	20-WAY MULTILOCK 070 / WHITE	FASCIA TOP CONNECTOR MOUNTING BRACKET / RIGHT HAND SIDE
AC13	20-WAY MULTILOCK 070 / YELLOW	FASCIA BOTTOM CONNECTOR MOUNTING BRACKET / RIGHT HAND SIDE
BT2	20-WAY MULTILOCK 070 / WHITE	TRUNK / ABOVE RIGHT HAND REAR WHEEL ARCH
EM1	20-WAY MULTILOCK 070 / WHITE	ENGINE COMPARTMENT / ADJACENT TO RIGHT HAND ENCLOSURE
EM2	18-WAY MULTILOCK 070 / YELLOW	ENGINE COMPARTMENT / ADJACENT TO RIGHT HAND ENCLOSURE
EM3	14-WAY MULTILOCK 070 / GREY	ENGINE COMPARTMENT / ADJACENT TO RIGHT HAND ENCLOSURE
IJ1	16-WAY AUGAT 1.6 / BLACK	ENGINE COMPARTMENT / FORWARD OF INTAKE MANIFOLD
IJ2	16-WAY AUGAT 1.6 / BLACK	ENGINE COMPARTMENT / FORWARD OF INTAKE MANIFOLD
LF3	13-WAY ECONOSEAL III LC / WHITE	ENGINE COMPARTMENT / LEFT HAND ENCLOSURE
LF40	13-WAY ECONOSEAL III LC / BLACK	ENGINE COMPARTMENT / LEFT HAND ENCLOSURE
PI1	57-WAY SUMITOMO / BLACK	ENGINE COMPARTMENT / BRACKET ON TOP OF TRANSMISSION
PI2	13-WAY ECONOSEAL III LC / BLACK	ENGINE COMPARTMENT / BRACKET ON TOP OF TRANSMISSION
RH1	20-WAY MULTILOCK 070 / GREY	BEHIND GLOVE BOX
RH2	20-WAY MULTILOCK 070 / WHITE	REAR OF CENTER CONSOLE ASSEMBLY
SC3	12-WAY MULTILOCK 070 / GREY	RIGHT HAND SIDE OF STEERING COLUMN
SW1	12-WAY MULTILOCK 040 / BLACK	INSIDE STEERING COLUMN COWL
SW2	6-WAY JST / WHITE	CENTER OF STEERING WHEEL

GROUNDINGS

Ground	Location / Type
BT2AL	EYELET (PAIR) - LEFT HAND LEG / TRUNK, RIGHT REAR
EM1AR	EYELET (PAIR) - RIGHT HAND LEG / ENGINE COMPARTMENT, RIGHT HAND ENCLOSURE
EM2AR	EYELET (PAIR) - RIGHT HAND LEG / ENGINE COMPARTMENT, LEFT HAND ENCLOSURE
FC3BL	EYELET (PAIR) - LEFT HAND LEG / TRANSMISSION TUNNEL, LEFT HAND SIDE
LF2AL	EYELET (PAIR) - LEFT HAND LEG / ENGINE COMPARTMENT, FORWARD OF LEFT HAND HOOD CATCH
LF2BL	EYELET (PAIR) - LEFT HAND LEG / ENGINE COMPARTMENT, FORWARD OF LEFT HAND HOOD CATCH

CONTROL MODULE PIN OUT INFORMATION (FOLD OUT PAGE)



REFER TO THE FRONT OF THE BOOK FOR ILLUSTRATIONS DETAILING THE LOCATION AND IDENTIFICATION OF COMPONENTS, RELAYS, CONNECTORS, HARNESSSES, GROUNDS, VEHICLE CONTROL MODULES AND CONTROL MODULE PINS.

DATE OF ISSUE: FEBRUARY 1998

CONTROL MODULE PIN OUT INFORMATION

TRANSMISSION CONTROL MODULE: AJ26 N/A

Pin	Description	Active	Inactive
O EM7-1	PRESSURE REGULATOR #2	GROUND (MAXIMUM PRESSURE)	B- (NO PRESSURE)
O EM7-2	SPORT MODE SWITCH STATUS LED	GROUND = LED ON	B-
O EM7-4	PRESSURE REGULATOR #4	GROUND (MAXIMUM PRESSURE)	B- (NO PRESSURE)
O EM7-5	PRESSURE REGULATOR #1	GROUND (MAXIMUM PRESSURE)	B- (NO PRESSURE)
I EM7-6	GROUND	GROUND	GROUND
I EM7-8	ROTARY SWITCH 'L2' CONTACTS	B-	GROUND
I EM7-9	ROTARY SWITCH 'L4' CONTACTS	B-	GROUND
I EM7-12	SPORT MODE SWITCH STRATEGY SELECT	GROUND = SPORT	GROUND
I EM7-13	D - 4 SWITCH	GROUND	GROUND
I EM7-14	TURBINE SPEED SENSOR	300 Hz @ IDLE (2.5 V)	B+
SG EM7-15	OUTPUT SPEED SENSOR SHIELD	GROUND	GROUND
SG EM7-16	OUTPUT SPEED SENSOR	GROUND	GROUND
EM7-18	NOT USED		
SG EM7-21	FLUID TEMPERATURE SENSOR	1.31 V	
I EM7-22	FLUID TEMPERATURE SENSOR FEEDBACK	1.15 V @ 90°C	
I EM7-23	TURBINE SPEED SENSOR SHIELD	GROUND	GROUND
I EM7-26	BATTERY POWER SUPPLY	B-	B-
O EM7-28	ROTARY / D-4 / KICK DOWN SWITCHES COMMON GROUND	GROUND	GROUND
O EM7-29	PRESSURE REGULATOR #3	GROUND (MAXIMUM PRESSURE)	B- (NO PRESSURE)
O EM7-30	SOLENOID VALVE #1	GROUND	B+
O EM7-32	SOLENOID VALVE #3	GROUND	B+
O EM7-33	SOLENOID VALVE #2	GROUND	B+
I EM7-34	GROUND	GROUND	GROUND
I EM7-36	ROTARY SWITCH 'L1' CONTACTS	B+	GROUND
I EM7-37	ROTARY SWITCH 'L3' CONTACTS	B+	GROUND
I EM7-42	TURBINE SPEED SENSOR	1.51 V @ 10 MPH (16 KM/H) = 250 Hz, 20 MPH (32 KM/H) = 500 Hz	
I EM7-44	OUTPUT SPEED SENSOR	1.51 V @ 10 MPH (16 KM/H) = 223 Hz, 20 MPH (32 KM/H) = 446 Hz	
I EM7-45	SPORT MODE SWITCH STRATEGY SELECT	10 v = SPORT	GROUND = NORMAL
O EM7-51	PRESSURE REGULATOR #5	GROUND (MAXIMUM PRESSURE)	B- (NO PRESSURE)
O EM7-52	SOLENOID VALVES COMMON SUPPLY	B+	B+
O EM7-53	PRESSURE REGULATORS COMMON SUPPLY	B+	B+
I EM7-54	IGNITION SWITCHED POWER SUPPLY	B+	GROUND
I EM7-55	IGNITION SWITCHED POWER SUPPLY	B+	GROUND
C EM7-82	CAN NETWORK	15 - 1500 Hz	
C EM7-83	CAN NETWORK	15 - 1500 Hz	
C EM7-85	CAN NETWORK	15 - 1500 Hz	
C EM7-86	CAN NETWORK	15 - 1500 Hz	

GEAR SELECTOR ILLUMINATION MODULE

Pin	Description	Active	Inactive
I FC88-1	IGNITION SWITCHED POWER SUPPLY	B+	GROUND
C FC88-3	CAN NETWORK	15 - 1500 Hz @ 2.5 V	
C FC88-4	CAN NETWORK	15 - 1500 Hz @ 2.5 V	
I FC88-6	GROUND	GROUND	GROUND
C FC88-8	CAN NETWORK	15 - 1500 Hz @ 2.5 V	
C FC88-9	CAN NETWORK	15 - 1500 Hz @ 2.5 V	

NOTE: REFER TO THE APPENDIX AT THE REAR OF THIS BOOK FOR CAN AND SCP NETWORK MESSAGES.

The following symbols are used to represent values for Control Module Pin Out data:

I	Input	D	Serial and encoded communications	B+	Battery voltage	KHz	Frequency x 1000
O	Output	C	CAN (Network)	V	Voltage (DC)	MS	Milliseconds
SG	Signal Ground	S	SCP Network	Hz	Frequency	MV	Millivolts

CAUTION: The information on this data page is furnished to aid the user in understanding circuit operation. THIS INFORMATION SHOULD BE USED FOR REFERENCE ONLY.

NOTE: The values listed are approximately those that can be expected at the control module connector pins with all circuit connections made and all components connected and fitted. "Active" means a load is applied or a switch is ON; "Inactive" means a load is not applied or a switch is OFF.

Fig. 05.1

COMPONENTS

Component	Connector / Type / Color	Location / Access
D - 4 SWITCH	FC83 / 3-WAY MULTILOCK 070 / YELLOW	GEAR SELECTOR ASSEMBLY, REAR
GEAR SELECTOR ILLUMINATION MODULE	FC88 / 10-WAY MULTILOCK 070 / WHITE	FRONT OF GEAR SELECTOR ASSEMBLY
MODE SWITCH (TRANSMISSION)	FC35 / 10-WAY AMP MOL / BLACK	REARWARD OF GEAR SELECTOR
TRANSMISSION CONTROL MODULE: AJ26 N/A	EM7 / 88-WAY BOSCH / BLACK	ENGINE COMPARTMENT / CONTROL MODULE ENCLOSURE
TRANSMISSION ELECTRICAL CONNECTOR: AJ26 N/A	EM46 / 16-WAY KOSTAL / BLACK	TRANSMISSION / LEFT HAND SIDE
TRANSMISSION ROTARY SWITCH	EM47 / 10-WAY RCINSIIAGEN MPL50 / BLACK	TRANSMISSION / RIGHT HAND SIDE

HARNESSTO-HARNESSTO CONNECTORS

Connector	Type / Color	Location / Access
AC12	20-WAY MULTILOCK 070 / WHITE	FASCIA TOP CONNECTOR MOUNTING BRACKET / RIGHT HAND SIDE
EM1	20-WAY MULTILOCK 070 / WHITE	ENGINE COMPARTMENT / ADJACENT TO RIGHT HAND ENCLOSURE
EM3	14-WAY MULTILOCK 070 / GREY	ENGINE COMPARTMENT / ADJACENT TO RIGHT HAND ENCLOSURE

GROUNDS

Ground	Location / Type
EM1A1	EYELET (PAIR) - LEFT HAND LEG / ENGINE COMPARTMENT, RIGHT HAND ENCLOSURE
EM2A1	EYELET (PAIR) - LEFT HAND LEG / ENGINE COMPARTMENT, LEFT HAND ENCLOSURE
FC3B1	EYELET (PAIR) - RIGHT HAND LEG / TRANSMISSION TUNNEL, LEFT HAND SIDE

CONTROL MODULE PIN OUT INFORMATION (FOLD OUT PAGE)



CONTROL MODULE PIN OUT INFORMATION

GEAR SELECTOR ILLUMINATION MODULE

Pin	Description	Active	Inactive
I FC88-1	IGNITION SWITCHED POWER SUPPLY	B+	GROUND
C FC88-3	CAN NETWORK	15 - 1500 Hz @ 2.5 V	
C FC88-4	CAN NETWORK	15 - 1500 Hz @ 2.5 V	
I FC88-6	GROUND	GROUND	GROUND
C FC88-8	CAN NETWORK	15 - 1500 Hz @ 2.5 V	
C FC88-9	CAN NETWORK	15 - 1500 Hz @ 2.5 V	

TRANSMISSION CONTROL MODULE: AJ26 SC

Pin	Description	Active	Inactive
C EM72-L	CAN NETWORK	5 - 1500 Hz	
C EM72-H	CAN NETWORK	5 - 1500 Hz	
I EM72-12	n2 SPEED SENSOR FEEDBACK	6V = 900 Hz @ 10 MPH (16 KPH); 1800 HZ @ 20 MPH (32 KH) ('2' SELECTED - '1' ENGAGED)	
O EM72-13	SPEED SENSOR COMMON VOLTAGE SUPPLY	5V	
O EM72-14	'1-2 / 4-5' SOLENOID ACTIVATE	GROUND	B+
O EM72-15	'3-4' SOLENOID ACTIVATE	GROUND	B+
O EM72-16	'2-3' SOLENOID ACTIVATE	GROUND	B-
O EM72-17	TCC SOLENOID ACTIVATE	GROUND = LOCKED	B+ = UNLOCKED
O EM72-33	SPEED SENSOR / FLUID TEMP. SENSOR COMMON GROUND	GROUND	GROUND
I EM72-34	FLUID TEMP. SENSOR FEEDBACK	1.75 V @ 90° C = R, D, 4, 3, 2	5 V = P, N
I EM72-35	n3 SPEED SENSOR FEEDBACK	6 V = 85 Hz @ 10 MPH (16 KPH); 170 Hz @ 20 MPH (32 KPH) ('2' SELECTED - '2' ENGAGED)	
O EM72-36	MODULATION PRESSURE REGULATOR ACTIVATE	GROUND (42% PWM @ IDLE)	B-
O EM72-37	SHIFT PRESSURE REGULATOR ACTIVATE	GROUND (39% PWM @ IDLE)	B-
O EM72-38	SOLENOID VALVE / PRESSURE REGULATOR COMMON VOLTAGE SUPPLY	B+	GROUND
I EM73-2	KICKDOWN SWITCH	GROUND (= WOT)	B+ (< WOT)
I EM73-3	SPORT MODE SWITCH	0 V = SPORT; 0 V = NORMAL	
I EM73-25	DUAL LINEAR SWITCH VOLTAGE ENCODED GEAR RECOGNITION	GROUND = R, D, 4, 3	B+ = P, N, 2
I EM73-26	DUAL LINEAR SWITCH VOLTAGE ENCODED GEAR RECOGNITION	GROUND = N, D, 4, 2	B+ = P, R, 3
I EM73-27	DUAL LINEAR SWITCH VOLTAGE ENCODED GEAR RECOGNITION	GROUND = N, 4, 3, 2	B+ = P
I EM73-28	DUAL LINEAR SWITCH VOLTAGE ENCODED GEAR RECOGNITION	GROUND = P, D, 3, 2	B+ = R, N, 4
I EM73-29	IGNITION SUPPLIED VOLTAGE	B+	GROUND
I EM73-30	TCM / DUAL LINEAR SWITCH COMMON GROUND SUPPLY	GROUND	GROUND

NOTE: REFER TO THE APPENDIX AT THE REAR OF THIS BOOK FOR CAN AND SCP NETWORK MESSAGES.

Fig. 05.2

COMPONENTS

Component	Connector / Type / Color	Location / Access
DUAL LINEAR SWITCH	FC100 / 12-WAY MULTILOCK 070 / GREY	LEFT HAND SIDE OF GEAR SELECTOR / CENTER CONSOLE
GEAR SELECTOR ILLUMINATION MODULE	FC88 / 10-WAY MULTILOCK 070 / WHITE	FRONT OF GEAR SELECTOR ASSEMBLY
KICKDOWN SWITCH	AC25 / 2-WAY / ECONOSEAL III LC / BLACK	UNDER ACCELERATOR PEDAL
MODE SWITCH (TRANSMISSION)	FC35 / 10-WAY AMP MQL / BLACK	REARWARD OF GEAR SELECTOR
TRANSMISSION CONTROL MODULE: AJ26 SC	EM72 / 14-WAY AMP JUNIOR POWER TIMER / BLACK EM73 / 18-WAY AMP JUNIOR POWER TIMER / BLACK	ENGINE COMPARTMENT / CONTROL MODULE ENCLOSURE
TRANSMISSION ELECTRICAL CONNECTOR: AJ26 SC	GB1 / 13-WAY KOSTAL 1.5 / BLACK	TRANSMISSION

HARNESS-TO-HARNESS CONNECTORS

Connector	Type / Color	Location / Access
AC12	20-WAY MULTILOCK 070 / WHITE	FASCIA TOP CONNECTOR MOUNTING BRACKET / RIGHT HAND SIDE
EM1	20-WAY MULTILOCK 070 / WHITE	ENGINE COMPARTMENT / ADJACENT TO RIGHT HAND ENCLOSURE
EM2	18-WAY MULTILOCK 070 / YELLOW	ENGINE COMPARTMENT / ADJACENT TO RIGHT HAND ENCLOSURE
EM3	14-WAY MULTILOCK 070 / GREY	ENGINE COMPARTMENT / ADJACENT TO RIGHT HAND ENCLOSURE
GB2	12-WAY AUGAT 1.6 / BLACK	ENGINE COMPARTMENT / BRACKET ON TOP OF TRANSMISSION

GROUNDS

Ground	Location / Type
EM1AL	EYELET (PAIR) - LEFT HAND LEG / ENGINE COMPARTMENT, RIGHT HAND ENCLOSURE
EM2AL	EYELET (PAIR) - LEFT HAND LEG / ENGINE COMPARTMENT, LEFT HAND ENCLOSURE
FC3BL	EYELET (PAIR) - LEFT HAND LEG / TRANSMISSION TUNNEL, LEFT HAND SIDE
FC3BR	EYELET (PAIR) - RIGHT HAND LEG / TRANSMISSION TUNNEL, LEFT HAND SIDE

CONTROL MODULE PIN OUT INFORMATION (FOLD OUT PAGE)



The following symbols are used to represent values for Control Module Pin Out data:

I	Input	D	Serial and encoded communications	B+	Battery voltage	KHz	Frequency x 1000
O	Output	C	CAN (Network)	V	Voltage (DC)	MS	Milliseconds
SG	Signal Ground	S	SCP Network	Hz	Frequency	MV	Millivolts

CAUTION: The information on this data page is furnished to aid the user in understanding circuit operation. THIS INFORMATION SHOULD BE USED FOR REFERENCE ONLY.

NOTE: The values listed are approximately those that can be expected at the control module connector pins with all circuit connections made and all components connected and fitted. "Active" means a load is applied or a switch is ON; "Inactive" means a load is not applied or a switch is OFF.

REFER TO THE FRONT OF THE BOOK FOR ILLUSTRATIONS DETAILING THE LOCATION AND IDENTIFICATION OF COMPONENTS, RELAYS, CONNECTORS, HARNESSSES, GROUNDS, VEHICLE CONTROL MODULES AND CONTROL MODULE PINS.

CONTROL MODULE PIN OUT INFORMATION

BODY PROCESSOR MODULE

Pin	Description	Active	Inactive
I FC14-15	IGNITION SWITCHED GROUND SUPPLY	GROUND	GROUND
I FC14-32	IGNITION SWITCHED GROUND SUPPLY	GROUND	GROUND (GEARSHIFT LOCKED)
O FC14-48	GEARSHIFT INTERLOCK SOLENOID SUPPLY	B+ (GEARSHIFT FREE)	GROUND (KEY RELEASED)
O FC14-51	KEY LOCK SOLENOID SUPPLY	B+ (KEY CAPTIVE)	B+ (PARK)
I FC14-58	NOT-IN-PARK	GROUND (R,N,D,4,3,2)	B+
I FC14-80	BATTERY POWER SUPPLY (LOGIC)	B+	
S FC14-84	SCP NETWORK	2 - 1600 Hz	
S FC14-85	SCP NETWORK	2 - 1600 Hz	
I FC14-104	LIGHTING / MOTORS BATTERY POWER SUPPLY	B+	

ENGINE CONTROL MODULE

Pin	Description	Active	Inactive
I EM10-10	BRAKE SWITCH	GROUND	B+
C EM10-28	CAN NETWORK	15 - 1500 Hz	
C EM10-27	CAN NETWORK	15 - 1500 Hz	

GEAR SELECTOR ILLUMINATION MODULE

Pin	Description	Active	Inactive
C FC88-4	CAN NETWORK	15 - 1500 Hz @ 2.5 V	
C FC88-3	CAN NETWORK	15 - 1500 Hz @ 2.5 V	
C FC88-8	CAN NETWORK	15 - 1500 Hz @ 2.5 V	
C FC88-9	CAN NETWORK	15 - 1500 Hz @ 2.5 V	

MAJOR INSTRUMENT PACK

Pin	Description	Active	Inactive
S FC25-19	SCP NETWORK	2 - 1600 Hz	
S FC25-20	SCP NETWORK	2 - 1600 Hz	
C FC25-24	CAN NETWORK	15 - 1500 Hz	
C FC25-47	CAN NETWORK	15 - 1500 Hz	

NOTE: REFER TO THE APPENDIX AT THE REAR OF THIS BOOK FOR CAN AND SCP NETWORK MESSAGES.

Fig. 05.3

COMPONENTS

Component	Connector / Type / Color	Location / Access
BODY PROCESSOR MODULE	FC14 / 104-WAY AMP EEEC / GREY	PASSENGER SIDE FASCIA / AIRBAG BRACKET
BRAKE SWITCH	AC24 / 4-WAY MULTILOCK 070 / WHITE	TOP OF BRAKE PEDAL
ENGINE CONTROL MODULE	EM10 / 28-WAY MULTILOCK 040 / GREY EM11 / 16-WAY MULTILOCK 040 / GREY EM12 / 22-WAY MULTILOCK 040 / GREY EM13 / 34-WAY MULTILOCK 040 / GREY EM14 / 12-WAY MULTILOCK 47 / WHITE EM15 / 22-WAY MULTILOCK 47 / WHITE	ENGINE COMPARTMENT / CONTROL MODULE ENCLOSURE
GEAR SELECTOR ILLUMINATION MODULE	FC88 / 10-WAY MULTILOCK 070 / WHITE	FRONT OF GEAR SELECTOR ASSEMBLY
GEARSHIFT INTERLOCK SOLENOID	FC80 / 2-WAY MULTILOCK 070 / WHITE	GEAR SELECTOR ASSEMBLY
KEYLOCK SOLENOID (COLUMN SWITCHGEAR)	SC1 / 12-WAY MULTILOCK 070 / WHITE	STEERING COLUMN
MAJOR INSTRUMENT PACK	FC25 / 48-WAY AMP PCB SIGNAL / BLACK FC26 / 24-WAY AMP PCB SIGNAL / BLACK	FASCIA
NOT-IN-PARK MICROSWITCH	FC87 / 3-WAY MULTILOCK 070 / WHITE	GEAR SELECTOR ASSEMBLY

HARNESS-TO-HARNESS CONNECTORS

Connector	Type / Color	Location / Access
AC13	20-WAY MULTILOCK 070 / YELLOW	FASCIA BOTTOM CONNECTOR MOUNTING BRACKET / RIGHT HAND SIDE
EM1	20-WAY MULTILOCK 070 / WHITE	ENGINE COMPARTMENT / ADJACENT TO RIGHT HAND ENCLOSURE

GROUNDS

Ground	Location / Type
FC2BR	EYELET (PAIR) - RIGHT HAND LEG / RIGHT HAND 'A' POST
FC3BR	EYELET (PAIR) - RIGHT HAND LEG / TRANSMISSION TUNNEL, LEFT HAND SIDE
FC4BR	EYELET (PAIR) - RIGHT HAND LEG / LEFT HAND 'A' POST

CONTROL MODULE PIN OUT INFORMATION (FOLD OUT PAGE)



The following symbols are used to represent values for Control Module Pin Out data:

I	Input	D	Serial and encoded communications	B+	Battery voltage	KHz	Frequency x 1000
O	Output	C	CAN (Network)	V	Voltage (DC)	MS	Milliseconds
SG	Signal Ground	S	SCP Network	Hz	Frequency	MV	Millivolts

CAUTION: The information on this data page is furnished to aid the user in understanding circuit operation. THIS INFORMATION SHOULD BE USED FOR REFERENCE ONLY.

NOTE: The values listed are approximately those that can be expected at the control module connector pins with all circuit connections made and all components connected and fitted. "Active" means a load is applied or a switch is ON; "Inactive" means a load is not applied or a switch is OFF.

REFER TO THE FRONT OF THE BOOK FOR ILLUSTRATIONS DETAILING THE LOCATION AND IDENTIFICATION OF COMPONENTS, RELAYS, CONNECTORS, HARNESSSES, GROUNDS, VEHICLE CONTROL MODULES AND CONTROL MODULE PINS.

CONTROL MODULE PIN OUT INFORMATION

ABS / TRACTION CONTROL CONTROL MODULE

Pin	Description	Active	Inactive
O LF37-1	BRAKE FLUID RESERVOIR LEVEL SWITCH REFERENCE	B+	B+
I LF37-2	BRAKE SWITCH	GROUND	B+
I LF37-3	RH FRONT WHEEL SPEED SENSOR	2.5 V @ 10 MPH (16 KM/H) = 100 Hz; 20 MPH (32 KM/H) = 200 Hz	
SG LF37-4	RH FRONT WHEEL SPEED SENSOR	2.5 V @ REST	
C LF37-5	CAN NETWORK	15 - 1500 Hz	
SG LF37-6	RH REAR WHEEL SPEED SENSOR	2.5 V @ REST	
I LF37-7	RH REAR WHEEL SPEED SENSOR	2.5 V @ 10 MPH (16 KM/H) = 100 Hz; 20 MPH (32 KM/H) = 200 Hz	
I LF37-8	GROUND	GROUND	GROUND
I LF37-9	BATTERY POWER SUPPLY	B+	B+
LF37-10	NOT USED		
LF37-11	NOT USED		
I LF37-13	BRAKE FLUID RESERVOIR LEVEL SWITCH	GROUND	B+
I LF37-14	STABILITY / TRACTION CONTROL SWITCH	GROUND (MOMENTARY)	B+
C LF37-15	CAN NETWORK	15 - 1500 Hz	
O LF37-16	STABILITY / TRACTION CONTROL SWITCH STATE LED	GROUND	B+
I LF37-17	LH FRONT WHEEL SPEED SENSOR	2.5 V @ 10 MPH (16 KM/H) = 100 Hz; 20 MPH (32 KM/H) = 200 Hz	
SG LF37-18	LH FRONT WHEEL SPEED SENSOR	2.5 V @ REST	
LF37-19	NOT USED		
I LF37-20	IGNITION SWITCHED SUPPLY	B+	GROUND
I LF37-21	LH REAR WHEEL SPEED SENSOR	2.5 V @ 10 MPH (16 KM/H) = 100 Hz; 20 MPH (32 KM/H) = 200 Hz	
SG LF37-22	LH REAR WHEEL SPEED SENSOR	2.5 V @ REST	
I LF37-24	GROUND	GROUND	GROUND
I LF37-25	BATTERY POWER SUPPLY	B+	B+

NOTE: REFER TO THE APPENDIX AT THE REAR OF THIS BOOK FOR CAN AND SCP NETWORK MESSAGES.

Fig. 06.1

COMPONENTS

Component	Connector / Type / Color	Location / Access
ABS / TRACTION CONTROL CONTROL MODULE	LF37 / 25-WAY AMP HYBRID / BLACK	ENGINE COMPARTMENT / FRONT LEFT
BRAKE FLUID RESERVOIR	EM37 / 2-WAY AMP JUNIOR POWER TIMER / BLACK	ENGINE COMPARTMENT / BRAKE BOOSTER ENCLOSURE
BRAKE SWITCH	AC24 / 4-WAY MULTILOCK 070 / WHITE	TOP OF BRAKE PEDAL
STABILITY / TRACTION CONTROL SWITCH (CENTER CONSOLE SWITCH PACK)	FC55 / 20-WAY FORD IDC / BLACK	CENTER CONSOLE SWITCH PACK
WHEEL SPEED SENSOR - LH FRONT	FL1 / 2-WAY REINSHAGEN METRI 630 / BLACK	WHEEL HUB
WHEEL SPEED SENSOR - LH REAR	RL1 / 2-WAY REINSHAGEN METRI 630 / BLACK	WHEEL HUB
WHEEL SPEED SENSOR - RH FRONT	FR1 / 2-WAY REINSHAGEN METRI 630 / BLACK	WHEEL HUB
WHEEL SPEED SENSOR - RH REAR	RR1 / 2-WAY REINSHAGEN METRI 630 / BLACK	WHEEL HUB

HARNESS-TO-HARNESS CONNECTORS

Connector	Type / Color	Location / Access
AC13	20-WAY MULTILOCK 070 / YELLOW	FASCIA BOTTOM CONNECTOR MOUNTING BRACKET / RIGHT HAND SIDE
BT2	20-WAY MULTILOCK 070 / WHITE	TRUNK / ABOVE RIGHT HAND REAR WHEEL ARCH
BT72	2-WAY ECONOSEAL III LC / BLACK	REAR OF REAR HUB ASSEMBLY / LEFT HAND SIDE
BT73	2-WAY ECONOSEAL III LC / BLACK	REAR OF REAR HUB ASSEMBLY / RIGHT HAND SIDE
LF40	13-WAY ECONOSEAL III LC / BLACK	ENGINE COMPARTMENT / LEFT HAND ENCLOSURE
LF41	2-WAY ECONOSEAL III LC / BLACK	ENGINE COMPARTMENT / ADJACENT TO ENGINE COMPARTMENT FUSE BOX
LF42	2-WAY ECONOSEAL III LC / BLACK	ENGINE COMPARTMENT / ADJACENT TO AIR CLEANER
LF60	20-WAY MULTILOCK 070 / WHITE	LEFT HAND 'A' POST CONNECTOR MOUNTING BRACKET / 'A' POST TRIM
RH1	20-WAY MULTILOCK 070 / GREY	BEHIND GLOVE BOX

GROUNDS

Ground	Location / Type
FC2BR	EYELET (PAIR) - RIGHT HAND LEG / RIGHT HAND 'A' POST
FC4BR	EYELET (PAIR) - RIGHT HAND LEG / LEFT HAND 'A' POST
LF3AS	EYELET (SINGLE) / ENGINE COMPARTMENT, FORWARD OF LEFT HAND HOOD CATCH

CONTROL MODULE PIN OUT INFORMATION (FOLD OUT PAGE)



The following symbols are used to represent values for Control Module Pin Out data:

I Input	D Serial and encoded communications	B+ Battery voltage	KHz Frequency x 1000
O Output	C CAN (Network)	V Voltage (DC)	MS Milliseconds
SG Signal Ground	S SCP Network	Hz Frequency	MV Millivolts

CAUTION: The information on this data page is furnished to aid the user in understanding circuit operation. THIS INFORMATION SHOULD BE USED FOR REFERENCE ONLY.

NOTE: The values listed are approximately those that can be expected at the control module connector pins with all circuit connections made and all components connected and fitted. "Active" means a load is applied or a switch is ON; "Inactive" means a load is not applied or a switch is OFF.

REFER TO THE FRONT OF THE BOOK FOR ILLUSTRATIONS DETAILING THE LOCATION AND IDENTIFICATION OF COMPONENTS, RELAYS, CONNECTORS, HARNESSSES, GROUNDS, VEHICLE CONTROL MODULES AND CONTROL MODULE PINS.

CONTROL MODULE PIN OUT INFORMATION

AIR CONDITIONING CONTROL MODULE

Pin	Description	Active	Inactive
0	AC1-6	DEFROST VENT SERVO MOTOR	B+
0	AC1-7	CENTER VENT SERVO MOTOR	B+
0	AC1-8	LH FRESH / RECIRCULATION VENT MOTOR	B+
0	AC1-9	RH FRESH / RECIRCULATION VENT MOTOR	B+
0	AC1-12	FOOTWELL VENT SERVO MOTOR	B+
0	AC1-13	COOL AIR BYPASS VENT SERVO MOTOR	B+
0	AC1-19	DEFROST VENT SERVO MOTOR	B+
0	AC1-20	CENTER VENT SERVO MOTOR	B+
0	AC1-21	LH FRESH / RECIRCULATION VENT SERVO MOTOR	B+
0	AC1-22	RH FRESH / RECIRCULATION VENT SERVO MOTOR	B+
0	AC1-25	FOOTWELL SERVO MOTOR	B+
0	AC1-26	COOL AIR BYPASS SERVO MOTOR	B+
I	AC2-1	SOLAR SENSOR FEEDBACK	0.75 V - 4.75 V; INCREASING WITH SOLAR LOAD
I	AC2-2	CENTER VENT POTENTIOMETER FEEDBACK	> 3.5 V = OPEN
I	AC2-3	RH FRESH / RECIRCULATION VENT POTENTIOMETER FEEDBACK	> 3.5 V = OPEN
I	AC2-5	COOL AIR BYPASS VENT POTENTIOMETER FEEDBACK	> 3.5 V = OPEN
I	AC2-6	ENGINE COOLANT TEMPERATURE	2.5 V @ 90° C; DECREASING WITH TEMPERATURE
I	AC2-10	DEFROST VENT POTENTIOMETER FEEDBACK	> 3.5 V = OPEN
I	AC2-11	LH FRESH / RECIRCULATION VENT POTENTIOMETER FEEDBACK	> 3.5 V = OPEN
I	AC2-13	FOOTWELL VENT POTENTIOMETER FEEDBACK	> 3.5 V = OPEN
O	AC3-2	CLOCK	B+ (1.45 Hz)
D	AC3-3	SERIAL DATA OUTPUT TO CONTROL PANEL	
I	AC3-5	AMBIENT TEMPERATURE SENSOR FEEDBACK	2.18 V @ 25° C; DECREASING WITH TEMPERATURE
I	AC3-6	HEATER MATRIX TEMPERATURE SENSOR FEEDBACK	2.25 V @ 20° C; DECREASING WITH TEMPERATURE
D	AC3-7	SERIAL DATA INPUT FROM CONTROL PANEL	
O	AC3-8	START	B+ (MOMENTARY)
I	AC3-11	IN CAR TEMPERATURE SENSOR FEEDBACK	3.25 V @ 0° C; DECREASING WITH TEMPERATURE
I	AC3-12	EVAPORATOR TEMPERATURE SENSOR FEEDBACK	3.25 V @ 0° C; DECREASING WITH TEMPERATURE
I	AC4-1	IGNITION SWITCHED POWER SUPPLY	B+
I	AC4-2	ISOLATE RELAY CONTROLLED BATTERY POWER SUPPLY	B+
I	AC4-3	IGNITION SWITCHED GROUND	0 V
O	AC4-4	CONTROL PANEL BATTERY POWER SUPPLY	B+
I	AC4-5	BATTERY POWER SUPPLY	B+
I	AC4-6	ENGINE SPEED SIGNAL	5 V @ 1000 RPM = 45 Hz; 2000 RPM = 90 Hz
O	AC4-8	POTENTIOMETER COMMON REFERENCE VOLTAGE	5 V
D	AC4-10	SERIAL COMMUNICATIONS INPUT	
O	AC4-12	CONTROL PANEL BATTERY POWER SUPPLY	B+
I	AC4-13	GROUND	0 V
O	AC4-14	CONTROL PANEL GROUND SUPPLY	0 V
O	AC4-15	ISOLATE RELAY ACTIVE	B+
I	AC4-16	VEHICLE SPEED SIGNAL	22 Hz @ 10 MPH (16 KM/H); 44 Hz @ 20 MPH (32 KM/H) @ B+
O	AC4-18	ASPIRATOR MOTOR POWER SUPPLY	B+
O	AC4-19	POTENTIOMETER COMMON REFERENCE GROUND	0 V
I	AC4-20	GROUND	0 V
D	AC4-21	SERIAL COMMUNICATIONS OUTPUT	

Fig. 07.1

COMPONENTS

Component	Connector / Type / Color	Location / Access
AIR CONDITIONING CONTROL MODULE	AC1 / 26-WAY MULTILOCK 47 / GREY AC2 / 16-WAY MULTILOCK 47 / GREY AC3 / 12-WAY MULTILOCK 47 / GREY AC4 / 22-WAY MULTILOCK 47 / GREY	A/C UNIT / RIGHT HAND SIDE
AIR CONDITIONING CONTROL PANEL	FC43 / 12-WAY MULTILOCK 040 / BLUE	CENTER CONSOLE
AIR INTAKE - LH BLOWER	AC5 / 15-WAY SUMITOMO 090 HYBRID / GREEN	A/C UNIT / LEFT HAND SIDE
AIR INTAKE - RH BLOWER	AC6 / 15-WAY SUMITOMO 090 HYBRID / GREEN	A/C UNIT / RIGHT HAND SIDE
AMBIENT TEMPERATURE SENSOR	LF29 / 2-WAY YAZAKI 0902 / BLACK	ADJACENT TO RIGHT HAND HORN
ASPIRATOR ASSEMBLY	FC12 / 4-WAY MULTILOCK 070 / WHITE	DRIVER KNEE BOLSTER
EVAPORATOR / HEATER MATRIX ASSEMBLY	AC7 / 12-WAY MULTILOCK 040 / BLACK	A/C UNIT / LEFT HAND SIDE
SOLAR SENSOR	FC62 / 2-WAY MULTILOCK 070 / GREY	DRIVER SIDE FASCIA / ADJACENT TO DEFROST VENT
VENT ASSEMBLY	FC44 / 12-WAY MULTILOCK 040 / BLACK	A/C UNIT / TOP

RELAYS

Relay	Color / Stripe	Connector / Color	Location / Access
AIR CONDITIONING ISOLATE RELAY	BLACK / VIOLET	FC24 / VIOLET	RH FASCIA RELAYS

HARNESS-TO-HARNESS CONNECTORS

Connector	Type / Color	Location / Access
AC12	20-WAY MULTILOCK 070 / WHITE	FASCIA TOP CONNECTOR MOUNTING BRACKET / RIGHT HAND SIDE
AC13	20-WAY MULTILOCK 070 / YELLOW	FASCIA BOTTOM CONNECTOR MOUNTING BRACKET / RIGHT HAND SIDE
AC15	20-WAY MULTILOCK 070 / GREY	FASCIA BOTTOM CONNECTOR MOUNTING BRACKET / RIGHT HAND SIDE
AC15	20-WAY MULTILOCK 070 / GREY	FASCIA BOTTOM CONNECTOR MOUNTING BRACKET / RIGHT HAND SIDE
LF60	20-WAY MULTILOCK 070 / WHITE	LEFT HAND 'A' POST CONNECTOR MOUNTING BRACKET / 'A' POST TRIM

GROUNDS

Ground	Location / Type
FC2BR	EYELET (PAIR) - RIGHT HAND LEG / RIGHT HAND 'A' POST
FC3CS	EYELET (SINGLE) / TRANSMISSION TUNNEL, LEFT HAND SIDE
FC4BR	EYELET (PAIR) - RIGHT HAND LEG / LEFT HAND 'A' POST

CONTROL MODULE PIN OUT INFORMATION (FOLD OUT PAGE)



The following symbols are used to represent values for Control Module Pin Out data:

I	Input	D	Serial and encoded communications	B+	Battery voltage	KHz	Frequency x 1000
O	Output	C	CAN (Network)	V	Voltage (DC)	MS	Milliseconds
SG	Signal Ground	S	SCP Network	Hz	Frequency	MV	Millivolts

CAUTION: The information on this data page is furnished to aid the user in understanding circuit operation. THIS INFORMATION SHOULD BE USED FOR REFERENCE ONLY.

NOTE: The values listed are approximately those that can be expected at the control module connector pins with all circuit connections made and all components connected and fitted. "Active" means a load is applied or a switch is ON; "Inactive" means a load is not applied or a switch is OFF.

REFER TO THE FRONT OF THE BOOK FOR ILLUSTRATIONS DETAILING THE LOCATION AND IDENTIFICATION OF COMPONENTS, RELAYS, CONNECTORS, HARNESSES, GROUNDS, VEHICLE CONTROL MODULES AND CONTROL MODULE PINS.

CONTROL MODULE PIN OUT INFORMATION

ENGINE CONTROL MODULE

Pin	Description	Active	Inactive
0 EM10-2	A/CCM LOAD INHIBIT	GROUND	B+
1 EM10-3	A/CCM ELECTRICAL LOAD SIGNAL	B+	GROUND
1 EM10-4	A/CCM COMPRESSOR CLUTCH REQUEST	B+	GROUND
1 EM12-5	4-WAY REFRIGERANT SWITCH HIGH PRESSURE	GROUND @ 20 BAR (290 PSI)	B-
1 EM12-6	4-WAY REFRIGERANT SWITCH HIGH PRESSURE	GROUND @ 12 BAR (174 PSI)	B-
0 EM12-10	AIR CONDITIONING COMPRESSOR RELAY ACTIVATE	GROUND	B-
0 EM13-15	SERIES (LOW) SPEED FAN ACTIVATE	GROUND	B-
0 EM13-16	PARALLEL (HIGH) SPEED FAN ACTIVATE	GROUND	B-

AIR CONDITIONING CONTROL MODULE

Pin	Description	Active	Inactive
1 AC1-1	COMPRESSOR CLUTCH STATUS	B+ (ON)	0 V
0 AC1-2	HEATER VALVE ACTIVE	B+	0 V
0 AC1-3	RH BLOWER MOTOR RELAY ACTIVE	0 V	B+
0 AC1-4	LH / RH WINDSHIELD HEATER RELAYS ACTIVATE	0 V	B+
0 AC1-5	DOOR MIRROR HEATER RELAY ACTIVATE	0 V	B+
0 AC1-16	LH BLOWER MOTOR RELAY ACTIVATE	B+	0 V
0 AC1-17	HEATER PUMP RELAY ACTIVATE	0 V	B+
0 AC1-18	HEATED BACKLIGHT RELAY ACTIVATE	0 V	B+
1 AC2-7	RH BLOWER SPEED FEEDBACK	7.6 V = LOW SPEED	0.83 V = HIGH SPEED
0 AC2-8	RH BLOWER SPEED CONTROL DRIVE SIGNAL	1.3 V = LOW SPEED	0 V = HIGH SPEED
1 AC2-15	LH BLOWER SPEED FEEDBACK	7.6 V = LOW SPEED	0.83 V = HIGH SPEED
0 AC2-16	LH BLOWER SPEED CONTROL DRIVE SIGNAL	1.3 V = LOW SPEED	0 V = HIGH SPEED
0 AC3-1	AIR CONDITIONING ELECTRICAL LOAD SIGNAL	B+	0 V
1 AC4-7	LOAD INHIBIT	0 V	B+
0 AC4-9	COMPRESSOR CLUTCH ON REQUEST	B+	0 V
1 AC4-17	REFRIGERANT 4-WAY PRESSURE SWITCH	0 V (2 - 30 BAR)	B+ (OUT OF ACTIVE RANGE)

Fig. 07.2

COMPONENTS

Component	Connector / Type / Color	Location / Access
AIR CONDITIONING COMPRESSOR CLUTCH	PI36 / 1-WAY SUMITOMO 090 A-TYPE / BLACK	ENGINE COMPARTMENT / A/C COMPRESSOR
AIR CONDITIONING CONTROL MODULE	AC1 / 26-WAY MULTILOCK 47 / GREY AC2 / 16-WAY MULTILOCK 47 / GREY AC3 / 12-WAY MULTILOCK 47 / GREY AC4 / 22-WAY MULTILOCK 47 / GREY AC5 / 15-WAY SUMITOMO 090 HYBRID / GREEN AC6 / 15-WAY SUMITOMO 090 HYBRID / GREEN	A/C UNIT / RIGHT HAND SIDE
BLOWER MOTOR - LH	EM10 / 28-WAY MULTILOCK 040 / GREY	A/C UNIT / LEFT HAND SIDE
BLOWER MOTOR - RH	EM11 / 16-WAY MULTILOCK 040 / GREY	A/C UNIT / RIGHT HAND SIDE
ENGINE CONTROL MODULE	EM12 / 22-WAY MULTILOCK 040 / GREY EM13 / 34-WAY MULTILOCK 040 / GREY EM14 / 12-WAY MULTILOCK 47 / WHITE EM15 / 22-WAY MULTILOCK 47 / WHITE	ENGINE COMPARTMENT / CONTROL MODULE ENCLOSURE
FUSE BOX - ENGINE COMPARTMENT	LF5 / 10-WAY U.T.A. FUSEBOX / NATURAL LF6 / 10-WAY U.T.A. FUSEBOX / BLACK LF7 / 10-WAY U.T.A. FUSEBOX / GREEN LF8 / 10-WAY U.T.A. FUSEBOX / BLUE LF70 / EYELET	ENGINE COMPARTMENT / LEFT FRONT
FUSE BOX - TRUNK	BT10 / 10-WAY U.T.A. FUSEBOX / NATURAL BT11 / 10-WAY U.T.A. FUSEBOX / BLACK BT12 / 10-WAY U.T.A. FUSEBOX / GREEN BT13 / 10-WAY U.T.A. FUSEBOX / BLUE BT64 / EYELET	TRUNK / ELECTRICAL CARRIER
HEATED BACKLIGHT	RH17 / LUCAR RIGHT ANGLE	BACKLIGHT / RIGHT HAND SIDE
HEATER PUMP	EM41 / 2-WAY ECONOSEAL III LC / BLACK	ENGINE COMPARTMENT / BULKHEAD, LEFT HAND SIDE
HEATER VALVE	EM43 / 2-WAY ECONOSEAL III LC / WHITE	ENGINE COMPARTMENT / BULKHEAD, LEFT HAND SIDE
MIRROR - DRIVER	DD8 / 12-WAY MULTILOCK 040 / BLUE	DRIVER DOOR
MIRROR - PASSENGER	DP8 / 12-WAY MULTILOCK 040 / BLUE	PASSENGER DOOR
RADIATOR FAN CONTROL RELAY MODULE	LF9 / 8-WAY TRW / BLACK	ADJACENT TO LEFT HAND HORN
RADIATOR FAN - LH	LF13 / 2-WAY REINSHAGEN METRI 630 / BLACK	ENGINE COMPARTMENT / FRONT
RADIATOR FAN - RH	LF12 / 2-WAY REINSHAGEN METRI 630 / BLACK	ENGINE COMPARTMENT / FRONT
REFRIGERANT 4-WAY PRESSURE SWITCH	LF57 / 6-WAY ECONOSEAL III LC / BLACK	ENGINE COMPARTMENT / REARWARD OF RADIATOR
WINDSHIELD HEATER - LH	EM49 / 2-WAY AMP SERIES 187C / GREY	ENGINE COMPARTMENT /
WINDSHIELD HEATER - RH	EM48 / 2-WAY AMP SERIES 187C / GREY	ENGINE COMPARTMENT /

RELAYS

Relay	Color / Stripe	Connector / Color	Location / Access
AIR CONDITIONING COMPRESSOR CLUTCH RELAY	BROWN	BUS	LH ENCLOSURE RELAYS
BLOWER MOTOR RELAY - LH	BLACK / BLUE	AC20 / BLUE	DRIVESHAFT TUNNEL RELAYS
BLOWER MOTOR RELAY - RH	BLACK / BLUE	AC20 / BLUE	DRIVESHAFT TUNNEL RELAYS
DOOR MIRROR HEATER RELAY	BLACK / BLUE	FC28 / BLUE	LH FASCIA RELAYS
HEATED BACKLIGHT RELAY (#2)	BROWN	BUS	TRUNK RELAYS
HEATER PUMP RELAY (#1)	BROWN	BUS	ENGINE COMPARTMENT FUSE BOX RELAYS
WINDSHIELD HEATER RELAY - LH	BROWN	EM44 / BROWN	RH ENCLOSURE RELAYS
WINDSHIELD HEATER RELAY - RH	BROWN	EM45 / BROWN	RH ENCLOSURE RELAYS

HARNESSTO-HARNESSTO CONNECTORS

Connector	Type / Color	Location / Access
AC12	20-WAY MULTILOCK 070 / WHITE	FASCIA TOP CONNECTOR MOUNTING BRACKET / RIGHT HAND SIDE
AC13	20-WAY MULTILOCK 070 / YELLOW	FASCIA BOTTOM CONNECTOR MOUNTING BRACKET / RIGHT HAND SIDE
AC15	20-WAY MULTILOCK 070 / GREY	FASCIA BOTTOM CONNECTOR MOUNTING BRACKET / RIGHT HAND SIDE
BT2	20-WAY MULTILOCK 070 / WHITE	TRUNK / ABOVE RIGHT HAND REAR WHEEL ARCH
BT58	4-WAY ECONOSEAL III HC / BLACK	TRUNK / ABOVE RIGHT HAND REAR WHEEL ARCH
DD1	23-WAY AMP - FORD / BLACK	DRIVER SIDE 'A' POST MOUNTING BRACKET / 'A' POST TRIM
DP1	23-WAY AMP - FORD / BLACK	PASSENGER SIDE 'A' POST / 'A' POST TRIM
EM1	20-WAY MULTILOCK 070 / WHITE	ENGINE COMPARTMENT / ADJACENT TO RIGHT HAND ENCLOSURE
EM2	18-WAY MULTILOCK 070 / YELLOW	ENGINE COMPARTMENT / ADJACENT TO RIGHT HAND ENCLOSURE
LF3	13-WAY ECONOSEAL III LC / WHITE	ENGINE COMPARTMENT / LEFT HAND ENCLOSURE
LF40	13-WAY ECONOSEAL III LC / BLACK	ENGINE COMPARTMENT / LEFT HAND ENCLOSURE
LF60	20-WAY MULTILOCK 070 / WHITE	LEFT HAND 'A' POST CONNECTOR MOUNTING BRACKET / 'A' POST TRIM
PI1	57-WAY SUMITOMO / BLACK	ENGINE COMPARTMENT / BRACKET ON TOP OF TRANSMISSION
RH2	20-WAY MULTILOCK 070 / WHITE	REAR OF CENTER CONSOLE ASSEMBLY

GROUNDS

Ground	Location / Type
EM1AR	EYELET (PAIR) - RIGHT HAND LEG / ENGINE COMPARTMENT, RIGHT HAND ENCLOSURE
EM1BL	EYELET (PAIR) - RIGHT HAND LEG / ENGINE COMPARTMENT, RIGHT HAND ENCLOSURE
EM1BS	EYELET (SINGLE) / ENGINE COMPARTMENT, RIGHT HAND ENCLOSURE
EM2AR	EYELET (PAIR) - RIGHT HAND LEG / ENGINE COMPARTMENT, LEFT HAND ENCLOSURE
EM2BL	EYELET (PAIR) - LEFT HAND LEG / ENGINE COMPARTMENT, LEFT HAND ENCLOSURE
EM2BS	EYELET (SINGLE) / ENGINE COMPARTMENT, LEFT HAND ENCLOSURE
FC2AL	EYELET (PAIR) - LEFT HAND LEG / RIGHT HAND 'A' POST
FC4AL	EYELET (PAIR) - LEFT HAND LEG / LEFT HAND 'A' POST
LF2AL	EYELET (PAIR) - LEFT HAND LEG / ENGINE COMPARTMENT, FORWARD OF LEFT HAND HOOD CATCH
LF2AR	EYELET (PAIR) - RIGHT HAND LEG / ENGINE COMPARTMENT, FORWARD OF LEFT HAND HOOD CATCH
LF2BL	EYELET (PAIR) - LEFT HAND LEG / ENGINE COMPARTMENT, FORWARD OF LEFT HAND HOOD CATCH
RH2S	EYELET (SINGLE) / LEFT HAND REAR QUARTER

CONTROL MODULE PIN OUT INFORMATION (FOLD OUT PAGE)



REFER TO THE FRONT OF THE BOOK FOR ILLUSTRATIONS DETAILING THE LOCATION AND IDENTIFICATION OF COMPONENTS, RELAYS, CONNECTORS, HARNESSES, GROUNDS, VEHICLE CONTROL MODULES AND CONTROL MODULE PINS.

The following symbols are used to represent values for Control Module Pin Out data:

I Input	D Serial and encoded communications	B+ Battery voltage	KHz Frequency x 1000
O Output	C CAN (Network)	V Voltage (DC)	MS Milliseconds
SG Signal Ground	S SCP Network	Hz Frequency	MV Millivolts

CAUTION: The information on this data page is furnished to aid the user in understanding circuit operation. THIS INFORMATION SHOULD BE USED FOR REFERENCE ONLY.

NOTE: The values listed are approximately those that can be expected at the control module connector pins with all circuit connections made and all components connected and fitted. "Active" means a load is applied or a switch is ON; "Inactive" means a load is not applied or a switch is OFF.

CONTROL MODULE PIN OUT INFORMATION

MAJOR INSTRUMENT PACK

Pin	Description	Active	Inactive
I FC25-1	GROUND	GROUND	GROUND
I FC25-2	IGNITION SWITCHED POWER SUPPLY	B+	GROUND
O FC25-3	MINOR INSTRUMENT PACK BATTERY POWER SUPPLY	B+	B-
I FC25-6	ADAPTIVE DAMPING WARNING	GROUND	B-
I FC25-10	TRIP CYCLE	GROUND (MOMENTARY)	
I FC25-13	'A/B' TRIP SELECT	GROUND (MOMENTARY)	
I FC25-14	'ML/KM' SELECT	GROUND (MOMENTARY)	
S FC25-19	SCP NETWORK	2 - 1600 Hz	
S FC25-20	SCP NETWORK	2 - 1600 Hz	
C FC25-23	CAN NETWORK	15 - 1500 Hz	
C FC25-24	CAN NETWORK	15 - 1500 Hz	
I FC25-25	BATTERY POWER SUPPLY	B+	
I FC25-26	GROUND	GROUND	B+
I FC25-27	ILLUMINATION SUPPLY	B+	GROUND
O FC25-28	MINOR INSTRUMENT PACK ILLUMINATION SUPPLY	B+	GROUND
O FC25-33	GROUND REFERENCE	GROUND	GROUND
I FC25-35	'CLEAR' SELECT	GROUND (MOMENTARY)	
I FC25-36	'000' SELECT	GROUND (MOMENTARY)	
C FC25-47	CAN NETWORK	15 - 1500 Hz	
C FC25-48	CAN NETWORK	15 - 1500 Hz	
O FC26-1	BATTERY CHARGE WARNING	< 3 V	B+
O FC26-2	OIL PRESSURE WARNING	< 3 V ≠ < 3 PSI	B+
O FC26-3	ENGINE SPEED	5 V @ 1000 RPM = 45 Hz; 2000 RPM = 90 Hz	
O FC26-4	ENGINE COOLANT TEMPERATURE	6 V = 90° C	
O FC26-5	VEHICLE SPEED - A/CCM	22 Hz @ 10 MPH (16 KM/H); 44 Hz @ 20 MPH (32 KM/H) @ B+	
O FC26-6	VEHICLE SPEED - PAS	22 Hz @ 10 MPH (16 KM/H); 44 Hz @ 20 MPH (32 KM/H) @ B+	
O FC26-7	VEHICLE SPEED - ADAPTIVE DAMPING CONTROL MODULE	22 Hz @ 10 MPH (16 KM/H); 44 Hz @ 20 MPH (32 KM/H) @ B+	
O FC26-8	BATTERY VOLTAGE GAUGE POSITION FEEDBACK	5 V (MIDPOINT)	
O FC26-9	BATTERY VOLTAGE GAUGE POSITION FEEDBACK	5 V (MIDPOINT)	
O FC26-10	OIL PRESSURE GAUGE POSITION FEEDBACK	5 V = 0 PSI; 3.3 V = NORMAL (MIDPOINT)	
O FC26-11	BATTERY VOLTAGE GAUGE MOVEMENT	3.7 - 5 V (PULSE)	
O FC26-12	BATTERY VOLTAGE GAUGE MOVEMENT	3.7 - 5 V (PULSE)	
I FC26-13	FUEL LEVEL GAUGE FEEDBACK	B+ = EMPTY	0 V = FULL
O FC26-14	FUEL LEVEL GAUGE REFERENCE GROUND	GROUND	GROUND
O FC26-15	OIL PRESSURE GAUGE POSITION FEEDBACK	5 V = 0 PSI; 3.3 V = NORMAL (MIDPOINT)	
I FC26-16	AIR BAG MIL	GROUND (ON)	B+
O FC26-17	OIL PRESSURE GAUGE MOVEMENT	3.7 - 5 V (PULSE)	
O FC26-18	OIL PRESSURE GAUGE MOVEMENT	3.7 - 5 V (PULSE)	
I FC26-19	LOW OIL PRESSURE WARNING	> 3 V = > 3 PSI	B+
O FC26-20	VEHICLE SPEED	22 Hz @ 10 MPH (16 KM/H); 44 Hz @ 20 MPH (32 KM/H) @ B+	
I FC26-21	DIMMER OVERRIDE	GROUND	B+
I FC26-22	CHARGE WARNING	B+	GROUND
I FC26-23	LOW COOLANT WARNING	GROUND	B+

MINOR INSTRUMENT PACK

Pin	Description	Active	Inactive
I FC79-8	MINOR INSTRUMENT PACK ILLUMINATION SUPPLY	B+	B-
I FC79-9	OIL PRESSURE GAUGE MOVEMENT	3.7 - 5 V (PULSE)	
I FC79-10	OIL PRESSURE GAUGE MOVEMENT	3.7 - 5 V (PULSE)	
I FC79-11	CHARGE WARNING	< 3 V	B+
I FC79-12	BATTERY VOLTAGE GAUGE POSITION FEEDBACK	5 V (MIDPOINT)	
I FC79-13	BATTERY VOLTAGE GAUGE POSITION FEEDBACK	5 V (MIDPOINT)	
I FC79-14	BATTERY VOLTAGE GAUGE MOVEMENT	3.7 - 5 V (PULSE)	
I FC79-15	BATTERY VOLTAGE GAUGE MOVEMENT	3.7 - 5 V (PULSE)	
I FC79-16	GROUND	GROUND	GROUND
I FC79-17	BATTERY POWER SUPPLY	B+	B+
I FC79-18	LOW OIL PRESSURE WARNING	GROUND (< 3 PSI)	B+
I FC79-19	OIL PRESSURE GAUGE POSITION FEEDBACK	5 V = 0 PSI; 3.3 V = NORMAL (MIDPOINT)	
I FC79-20	OIL PRESSURE GAUGE POSITION FEEDBACK	5 V = 0 PSI; 3.3 V = NORMAL (MIDPOINT)	

NOTE: REFER TO THE APPENDIX AT THE REAR OF THIS BOOK FOR CAN AND SCP NETWORK MESSAGES.

The following symbols are used to represent values for Control Module Pin Out data:

I	Input	D	Serial and encoded communications	B+	Battery voltage	KHz	Frequency x 1000
O	Output	C	CAN (Network)	V	Voltage (DC)	MS	Milliseconds
SG	Signal Ground	S	SCP Network	Hz	Frequency	MV	Millivolts

CAUTION: The information on this data page is furnished to aid the user in understanding circuit operation. THIS INFORMATION SHOULD BE USED FOR REFERENCE ONLY.

NOTE: The values listed are approximately those that can be expected at the control module connector pins with all circuit connections made and all components connected and fitted. "Active" means a load is applied or a switch is ON; "Inactive" means a load is not applied or a switch is OFF.

Fig. 08.1

COMPONENTS

Component	Connector / Type / Color	Location / Access
COOLANT LEVEL SWITCH	EM55 / 2-WAY AMP JUNIOR POWER TIMER / BROWN	ENGINE COMPARTMENT / COOLANT RESERVOIR
FUEL LEVEL SENSOR	BT7 / LUCAR RIGHT ANGLE BT8 / LUCAR RIGHT ANGLE	TRUNK / FUEL TANK
MAJOR INSTRUMENT PACK	FC25 / 48-WAY AMP PCB SIGNAL / BLACK FC26 / 24-WAY AMP PCB SIGNAL / BLACK	FASCIA
MINOR INSTRUMENT PACK	FC79 / 20-WAY MULTILOCK 040 / BLACK	FASCIA
OIL PRESSURE SWITCH	PI40 / 1-WAY ECONOSEAL ECJ2 / BLACK	ENGINE BLOCK / RIGHT HAND SIDE
TRIP COMPUTER SWITCH PACK	FC27 / 10-WAY AMP MGL / BLACK	FASCIA / DRIVER SIDE
TRIP CYCLE SWITCH (COLUMN SWITCHGEAR)	SC2 / 10-WAY MULTILOCK 070 / YELLOW	STEERING COLUMN

HARNESS-TO-HARNESS CONNECTORS

Connector	Type / Color	Location / Access
BT2	20-WAY MULTILOCK 070 / WHITE	TRUNK / ABOVE RIGHT HAND REAR WHEEL ARCH
EM1	20-WAY MULTILOCK 070 / WHITE	ENGINE COMPARTMENT / ADJACENT TO RIGHT HAND ENCLOSURE
EM2	18-WAY MULTILOCK 070 / YELLOW	ENGINE COMPARTMENT / ADJACENT TO RIGHT HAND ENCLOSURE
PI1	57-WAY SUMITOMO / BLACK	ENGINE COMPARTMENT / BRACKET ON TOP OF TRANSMISSION
RH1	20-WAY MULTILOCK 070 / GREY	BEHIND GLOVE BOX

GROUNDS

Ground	Location / Type
EM1BR	EYELET (PAIR) - RIGHT HAND LEG / ENGINE COMPARTMENT, RIGHT HAND ENCLOSURE
EM2BR	EYELET (PAIR) - RIGHT HAND LEG / ENGINE COMPARTMENT, LEFT HAND ENCLOSURE
FC2BR	EYELET (PAIR) - RIGHT HAND LEG / RIGHT HAND 'A' POST
FC3BL	EYELET (PAIR) - LEFT HAND LEG / TRANSMISSION TUNNEL, LEFT HAND SIDE
FC4BR	EYELET (PAIR) - RIGHT HAND LEG / LEFT HAND 'A' POST

CONTROL MODULE PIN OUT INFORMATION (FOLD OUT PAGE)



CONTROL MODULE PIN OUT INFORMATION

BODY PROCESSOR MODULE

Pin	Description	Active	Inactive
I FC14-15	IGNITION SWITCHED GROUND SUPPLY	GROUND	
I FC14-32	IGNITION SWITCHED GROUND SUPPLY	GROUND	GROUND
I FC14-41	IGNITION SWITCHED GROUND SUPPLY	GROUND	
I FC14-80	BATTERY POWER SUPPLY (LOGIC)	B+	B+
O FC14-82	AUDIBLE WARNING SPEAKER OUTPUT	AUDIO OUTPUT	
O FC14-83	AUDIBLE WARNING SPEAKER OUTPUT	AUDIO OUTPUT	
S FC14-84	SCP NETWORK	2 - 1600 Hz	
S FC14-85	SCP NETWORK	2 - 1600 Hz	
I FC14-104	BATTERY POWER SUPPLY	B+	B+

NOTE: REFER TO THE APPENDIX AT THE REAR OF THIS BOOK FOR CAN AND SCP NETWORK MESSAGES.

Fig. 08.2

COMPONENTS

Component	Connector / Type / Color	Location / Access
AUDIBLE WARNING SPEAKER (COLUMN SWITCHGEAR) BODY PROCESSOR MODULE	SC1 / 12-WAY MULTILOCK 070 / WHITE FC14 / 104-WAY AMP EEEC / GREY	STEERING COLUMN / RIGHT HAND SIDE PASSENGER SIDE FASCIA / AIRBAG BRACKET

CONTROL MODULE PIN OUT INFORMATION (FOLD OUT PAGE)



The following symbols are used to represent values for Control Module Pin Out data:

I Input	D Serial and encoded communications	B+ Battery voltage	KHz Frequency x 1000
O Output	C CAN (Network)	V Voltage (DC)	MS Milliseconds
SG Signal Ground	S SCP Network	Hz Frequency	MV Millivolts

CAUTION: The information on this data page is furnished to aid the user in understanding circuit operation. THIS INFORMATION SHOULD BE USED FOR REFERENCE ONLY.

NOTE: The values listed are approximately those that can be expected at the control module connector pins with all circuit connections made and all components connected and fitted. "Active" means a load is applied or a switch is ON; "Inactive" means a load is not applied or a switch is OFF.

REFER TO THE FRONT OF THE BOOK FOR ILLUSTRATIONS DETAILING THE LOCATION AND IDENTIFICATION OF COMPONENTS, RELAYS, CONNECTORS, HARNESSSES, GROUNDS, VEHICLE CONTROL MODULES AND CONTROL MODULE PINS.

CONTROL MODULE PIN OUT INFORMATION

BODY PROCESSOR MODULE

Pin	Description	Active	Inactive
O FC14-1	RH FRONT SIDE LAMP BULB SUPPLY	B+	GROUND
O FC14-2	LH FRONT DI BULB SUPPLY	B+ (PULSED)	GROUND
O FC14-3	RH FRONT DI BULB SUPPLY	B+ (PULSED)	GROUND
I FC14-14	HEADLAMP MAIN BEAM REQUEST	GROUND	B+
I FC14-15	IGNITION SWITCHED GROUND SUPPLY	GROUND	B+
I FC14-16	SIDE LAMP REQUEST	GROUND	B-
O FC14-20	FRONT FOG LAMP RELAY ACTIVATE / STATUS LED	GROUND (LIGHTS ON / LED ON)	R-
O FC14-27	LH SIDE DI REPEATER SUPPLY (ROW ONLY)	B+	GROUND
O FC14-28	RH SIDE DI REPEATER SUPPLY (ROW ONLY)	B+	GROUND
I FC14-30	HEADLAMP FLASH REQUEST	GROUND (MOMENTARY)	B-
I FC14-38	FRONT FOG LAMP SWITCH	GROUND (MOMENTARY)	B+
I FC14-41	IGNITION GROUND SUPPLY	GROUND	B+
I FC14-42	DIPPED BEAM REQUEST	GROUND	B+
O FC14-45	MAIN BEAM RELAY ACTIVATE	GROUND	B+
O FC14-53	LH FRONT SIDE LAMP SUPPLY	B+ (LIGHT ON)	GROUND
O FC14-54	LH SIDE MARKER SUPPLY (NAS ONLY)	B+ (LIGHT ON)	GROUND
I FC14-59	HAZARD LAMP REQUEST	GROUND (MOMENTARY)	B+
I FC14-61	RH DI REQUEST	GROUND	B+
O FC14-68	DIP BEAM RELAY ACTIVATE	GROUND (LIGHTS ON)	B+
I FC14-79	BATTERY POWER SUPPLY	B+	B+
I FC14-80	BATTERY POWER SUPPLY (LOGIC)	B+	B+
O FC14-81	RH SIDE DI REPEATER SUPPLY (ROW ONLY)	B+ (LIGHTS ON)	B-
S FC14-84	SCP NETWORK	2 - 1600 Hz	GROUND
S FC14-85	SCP NETWORK	2 - 1600 Hz	B+
I FC14-88	LH DI REQUEST	GROUND	GROUND
O FC14-96	HAZARD STATUS INDICATOR	B+ (PULSED)	GROUND

MAJOR INSTRUMENT PACK

Pin	Description	Active	Inactive
S FC25-19	SCP NETWORK	2 - 1600 Hz	
S FC25-20	SCP NETWORK	2 - 1600 Hz	

NOTE: REFER TO THE APPENDIX AT THE REAR OF THIS BOOK FOR CAN AND SCP NETWORK MESSAGES.

Fig. 09.1

COMPONENTS

Component	Connector / Type / Color	Location / Access
BODY PROCESSOR MODULE	FC14 / 104-WAY AMP EEEEC / GREY	PASSENGER SIDE FASCIA / AIRBAG BRACKET
CENTER CONSOLE SWITCH PACK	FC55 / 20-WAY FORD IDC / BLACK	CENTER CONSOLE
FRONT FOG LAMP - LH	LF32 / 2-WAY REINSHAGEN METRI 630 / BLACK	FRONT BUMPER / WHEEL ARCH LINER PANEL
FRONT FOG LAMP - RH	LF22 / 2-WAY REINSHAGEN METRI 630 / BLACK	FRONT BUMPER / WHEEL ARCH LINER PANEL
FRONT LAMP UNIT - LH	LF31 / 6-WAY ECONOSEAL III LC / BLACK	LEFT HAND HEADLAMP ASSEMBLY
FRONT LAMP UNIT - RH	LF21 / 6-WAY ECONOSEAL III LC / BLACK	RIGHT HAND HEADLAMP ASSEMBLY
FUSE BOX - ENGINE COMPARTMENT	LF5 / 10-WAY U.T.A. FUSEBOX / NATURAL LF6 / 10-WAY U.T.A. FUSEBOX / BLACK LF7 / 10-WAY U.T.A. FUSEBOX / GREEN LF8 / 10-WAY U.T.A. FUSEBOX / BLUE LF70 / EYELET	ENGINE COMPARTMENT / LEFT FRONT
LIGHTING STALK (COLUMN SWITCHGEAR)	SC2 / 10-WAY MULTILOCK 070 / YELLOW	STEERING COLUMN
MAJOR INSTRUMENT PACK	FC25 / 48-WAY AMP PCB SIGNAL / BLACK FC26 / 24-WAY AMP PCB SIGNAL / BLACK	FASCIA
SIDE DI REPEATER - LH (ROW)	LF4 / 2-WAY AMP JUNIOR POWER TIMER / BLACK	BEHIND WHEEL ARCH LINER
SIDE DI REPEATER - RH (ROW)	EL5 / 2-WAY AMP JUNIOR POWER TIMER / BLACK	BEHIND WHEEL ARCH LINER
FRONT SIDE MARKER - LH (NAS ONLY)	LF11 / 2-WAY AMP JUNIOR POWER TIMER / BLACK	BEHIND WHEEL ARCH LINER
FRONT SIDE MARKER - RH (NAS ONLY)	LF10 / 2-WAY AMP JUNIOR POWER TIMER / BLACK	BEHIND WHEEL ARCH LINER

RELAYS

Relay	Color / Stripe	Connector / Color	Location / Access
DIP BEAM RELAY (#5)	BROWN	BUS	ENGINE COMPARTMENT FUSE BOX
FRONT FOG RELAY (#2)	BROWN	BUS	ENGINE COMPARTMENT FUSE BOX
MAIN BEAM RELAY (#3)	BROWN	BUS	ENGINE COMPARTMENT FUSE BOX

HARNESSTO-HARNESSTO CONNECTORS

Connector	Type / Color	Location / Access
EL1	6-WAY ECONOSEAL III LC / BLACK	ENGINE COMPARTMENT / RIGHT HAND ENCLOSURE
LF1	20-WAY MULTILOCK 070 / GREY	LEFT HAND 'A' POST CONNECTOR MOUNTING BRACKET / 'A' POST TRIM
LF40	13-WAY ECONOSEAL III LC / BLACK	ENGINE COMPARTMENT / LEFT HAND ENCLOSURE

GROUNDS

Ground	Location / Type
EM1AR	EYELET (PAIR) - RIGHT HAND LEG / ENGINE COMPARTMENT, RIGHT HAND ENCLOSURE
EM2AR	EYELET (PAIR) - RIGHT HAND LEG / ENGINE COMPARTMENT, LEFT HAND ENCLOSURE
FC2BR	EYELET (PAIR) - RIGHT HAND LEG / RIGHT HAND 'A' POST
FC3BL	EYELET (PAIR) - LEFT HAND LEG / TRANSMISSION TUNNEL, LEFT HAND SIDE
FC3BR	EYELET (PAIR) - RIGHT HAND LEG / TRANSMISSION TUNNEL, LEFT HAND SIDE
FC4BR	EYELET (PAIR) - RIGHT HAND LEG / LEFT HAND 'A' POST
LF1AL	EYELET (PAIR) - LEFT HAND LEG / RIGHT HAND HEADLAMP
LF2BR	EYELET (PAIR) - RIGHT HAND LEG / ENGINE COMPARTMENT, FORWARD OF LEFT HAND HOOD CATCH

CONTROL MODULE PIN OUT INFORMATION (FOLD OUT PAGE)



The following symbols are used to represent values for Control Module Pin Out data:

I	Input	D	Serial and encoded communications	B+	Battery voltage	KHz	Frequency x 1000
O	Output	C	CAN (Network)	V	Voltage (DC)	MS	Milliseconds
SG	Signal Ground	S	SCP Network	Hz	Frequency	MV	Millivolts

CAUTION: The information on this data page is furnished to aid the user in understanding circuit operation. THIS INFORMATION SHOULD BE USED FOR REFERENCE ONLY.

NOTE: The values listed are approximately those that can be expected at the control module connector pins with all circuit connections made and all components connected and fitted. "Active" means a load is applied or a switch is ON; "Inactive" means a load is not applied or a switch is OFF.

REFER TO THE FRONT OF THE BOOK FOR ILLUSTRATIONS DETAILING THE LOCATION AND IDENTIFICATION OF COMPONENTS, RELAYS, CONNECTORS, HARNESSES, GROUNDS, VEHICLE CONTROL MODULES AND CONTROL MODULE PINS.

CONTROL MODULE PIN OUT INFORMATION

BODY PROCESSOR MODULE

Pin	Description	Active	Inactive
I FC14-12	REAR FOG LAMP REQUEST	GROUND (MOMENTARY)	B+
I FC14-15	IGNITION SWITCHED GROUND SUPPLY	GROUND	B+
I FC14-16	SIDE LAMP REQUEST	GROUND	B+
I FC14-41	IGNITION GROUND SUPPLY	GROUND	B+
I FC14-42	DIPPED BEAM REQUEST	GROUND	B+
O FC14-44	REAR FOG LAMP STATUS LED	GROUND (LED ON)	B+
O FC14-50	LH REAR DI LAMP SUPPLY	B- (LIGHT ON)	GROUND
I FC14-51	RH DI REQUEST	GROUND	B+
O FC14-76	RH REAR DI LAMP SUPPLY	B- (LIGHTS ON)	GROUND
I FC14-79	BATTERY POWER SUPPLY	B+	B+
I FC14-80	BATTERY POWER SUPPLY (LOGIC)	B+	B+
S FC14-84	SCP NETWORK	2 - 1600 Hz	B+
S FC14-85	SCP NETWORK	2 - 1600 Hz	B+
I FC14-88	LH DI REQUEST	GROUND	B+
O FC14-95	TAIL LAMP RELAY ACTIVATE	GROUND (LIGHTS ON)	B+
I FC14-104	LIGHTING / MOTORS BATTERY POWER SUPPLY	B+	B+

LAMP CONTROL MODULE

Pin	Description	Active	Inactive
I BT18-14	RH STOP LAMP SUPPLY	B+	GROUND
I BT18-15	LH STOP LAMP SUPPLY	B+	GROUND
I BT18-16	LH TAIL & SIDE MARKER LAMP SUPPLY	B+	GROUND
I BT18-17	RH TAIL & SIDE MARKER LAMP SUPPLY	B+	GROUND
O BT18-18	NUMBER PLATE LAMP SUPPLY	B+	GROUND
O BT18-19	LH STOP LAMP SUPPLY	B+	GROUND
O BT18-20	RH STOP LAMP SUPPLY	B+	GROUND
O BT18-21	LH TAIL LAMP SUPPLY	B+	GROUND
O BT18-22	RH TAIL LAMP SUPPLY	B+	GROUND
O BT18-23	SIDE MARKER LAMP SUPPLY	B+	GROUND
I BT18-24	IGNITION SWITCHED POWER SUPPLY	B+	GROUND
O BT18-25	SECURITY LIGHTING ON FEEDBACK	B+	GROUND
I BT18-26	GROUND	GROUND	GROUND

MAJOR INSTRUMENT PACK

Pin	Description	Active	Inactive
S FC25-19	SCP NETWORK	2 - 1600 Hz	B+
S FC25-20	SCP NETWORK	2 - 1600 Hz	B+
C FC25-24	CAN NETWORK	15 - 1500 Hz	B+
C FC25-47	CAN NETWORK	15 - 1500 Hz	B+

SECURITY AND LOCKING CONTROL MODULE

Pin	Description	Active	Inactive
O BT40-5	REVERSE LAMP SUPPLY	B+	GROUND
I BT40-6	BATTERY POWER SUPPLY	B+	B+
O BT40-7	REAR FOG LAMP RELAY ACTIVATE	GROUND	B+
S BT40-8	SCP NETWORK	2 - 1600 Hz	B+
I BT40-13	GROUND	GROUND	GROUND
I BT40-14	GROUND	GROUND	GROUND
S BT40-16	SCP NETWORK	2 - 1600 Hz	B+
I BT41-1	SECURITY LIGHTING ON FEEDBACK	B+	GROUND

NOTE: REFER TO THE APPENDIX AT THE REAR OF THIS BOOK FOR CAN AND SCP NETWORK MESSAGES.

The following symbols are used to represent values for Control Module Pin Out data:

I	Input	D	Serial and encoded communications	B+	Battery voltage	KHz	Frequency x 1000
O	Output	C	CAN (Network)	V	Voltage (DC)	MS	Milliseconds
SG	Signal Ground	S	SCP Network	Hz	Frequency	MV	Millivolts

CAUTION: The information on this data page is furnished to aid the user in understanding circuit operation. THIS INFORMATION SHOULD BE USED FOR REFERENCE ONLY.

NOTE: The values listed are approximately those that can be expected at the control module connector pins with all circuit connections made and all components connected and fitted. "Active" means a load is applied or a switch is ON; "Inactive" means a load is not applied or a switch is OFF.

Fig. 09.2

COMPONENTS

Component	Connector / Type / Color	Location / Access
BODY PROCESSOR MODULE	FC14 / 104-WAY AMP EEEEC / GREY	PASSENGER SIDE FASCIA / AIRBAG BRACKET
BRAKE SWITCH	AC24 / 4-WAY MULTILOCK 070 / WHITE	TOP OF BRAKE PEDAL
CENTER CONSOLE SWITCH PACK	FC55 / 20-WAY FORD IDC / BLACK	CENTER CONSOLE
FUSE BOX - TRUNK	BT10 / 10-WAY U.T.A. FUSEBOX / NATURAL BT11 / 10-WAY U.T.A. FUSEBOX / BLACK BT12 / 10-WAY U.T.A. FUSEBOX / GREEN BT13 / 10-WAY U.T.A. FUSEBOX / BLUE BT64 / EYELET	TRUNK / ELECTRICAL CARRIER
HIGH MOUNT STOP LAMP (CONV.)	BL8 / 2-WAY MULTILOCK 070 / WHITE	TRUNK / UNDERSIDE OF LID
HIGH MOUNT STOP LAMP (COUPE)	RH8 / 2-WAY MULTILOCK 070 / WHITE	TRUNK / REARWARD OF SUB WOOFER SPEAKER
LAMP CONTROL MODULE	BT18 / 26-WAY AMP MQS / YELLOW	TRUNK / ELECTRICAL CARRIER
LIGHTING STALK (COLUMN SWITCHGEAR)	SC2 / 10-WAY MULTILOCK 070 / YELLOW	STEERING COLUMN
MAJOR INSTRUMENT PACK	FC25 / 48-WAY AMP PCB SIGNAL / BLACK FC26 / 24-WAY AMP PCB SIGNAL / BLACK	FASCIA
NUMBER PLATE LAMP - LH	BL4 / 2-WAY AMP JUNIOR POWER TIMER / BLACK	TRUNK LID / LINER
NUMBER PLATE LAMP - RH	BL5 / 2-WAY AMP JUNIOR POWER TIMER / BLACK	TRUNK LID / LINER
SECURITY AND LOCKING CONTROL MODULE	BT40 / 16-WAY FORD 2.8 TIMER / BLACK BT41 / 26-WAY FORD IDC / BLACK RH20 / COAXIAL CONNECTOR	TRUNK / ELECTRICAL CARRIER
REAR SIDE MARKER - LH (NAS ONLY)	BT27 / 2-WAY AMP JUNIOR POWER TIMER / BLACK	TRUNK / LEFT HAND SIDE
REAR SIDE MARKER - RH (NAS ONLY)	BT26 / 2-WAY AMP JUNIOR POWER TIMER / BLACK	TRUNK / RIGHT HAND SIDE
TAIL LAMP UNIT - LH	BT31 / 7-WAY AMP JUNIOR TIMER / BLACK	TRUNK / LEFT HAND SIDE
TAIL LAMP UNIT - RH	BT30 / 7-WAY AMP JUNIOR TIMER / BLACK	TRUNK / RIGHT HAND SIDE

RELAYS

Relay	Color / Stripe	Connector / Color	Location / Access
REAR FOG RELAY (#1)	BROWN	BUS	TRUNK FUSE BOX
STOP LAMP RELAY (#5)	BROWN	BUS	TRUNK FUSE BOX
TAIL LAMP RELAY (#3)	BROWN	BUS	TRUNK FUSE BOX

HARNESSTO-HARNESSTO CONNECTORS

Connector	Type / Color	Location / Access
AC13	20-WAY MULTILOCK 070 / YELLOW	FASCIA BOTTOM CONNECTOR MOUNTING BRACKET / RIGHT HAND SIDE
BB1	3-WAY MULTILOCK 070 / YELLOW	TRUNK / ABOVE RIGHT HAND REAR WHEEL ARCH
BL1	4-WAY MULTILOCK 070 / WHITE	TRUNK / ABOVE RIGHT HAND REAR WHEEL ARCH
BT1	20-WAY MULTILOCK 070 / WHITE	TRUNK / ABOVE RIGHT HAND REAR WHEEL ARCH
BT2	20-WAY MULTILOCK 070 / WHITE	TRUNK / ABOVE RIGHT HAND REAR WHEEL ARCH
RH2	20-WAY MULTILOCK 070 / WHITE	REAR OF CENTER CONSOLE ASSEMBLY
RH12	18-WAY MULTILOCK 070 / YELLOW	REAR OF CENTER CONSOLE ASSEMBLY

GROUNDS

Ground	Location / Type
BT1AR	EYELET (PAIR) - RIGHT HAND LEG / ADJACENT TO BATTERY
BT2AR	EYELET (PAIR) - RIGHT HAND LEG / TRUNK, RIGHT REAR
BT3S	EYELET (SINGLE) / TRUNK, LEFT REAR
FC1BL	EYELET (PAIR) - LEFT HAND LEG / TRANSMISSION TUNNEL, RIGHT HAND SIDE
FC3BL	EYELET (PAIR) - LEFT HAND LEG / TRANSMISSION TUNNEL, LEFT HAND SIDE
FC3BR	EYELET (PAIR) - RIGHT HAND LEG / TRANSMISSION TUNNEL, LEFT HAND SIDE
RH1S	EYELET (SINGLE) / RIGHT HAND REAR QUARTER

CONTROL MODULE PIN OUT INFORMATION (FOLD OUT PAGE)



REFER TO THE FRONT OF THE BOOK FOR ILLUSTRATIONS DETAILING THE LOCATION AND IDENTIFICATION OF COMPONENTS, RELAYS, CONNECTORS, HARNESSES, GROUNDS, VEHICLE CONTROL MODULES AND CONTROL MODULE PINS.

Fig. 09.3**COMPONENTS**

Component	Connector / Type / Color	Location / Access
HEADLAMP LEVELING ACTUATOR - LH	LF34 / 3-WAY REINSHAGEN / BLACK	HEADLAMP ASSEMBLY / REAR
HEADLAMP LEVELING ACTUATOR - RH	LF24 / 3-WAY REINSHAGEN / BLACK	HEADLAMP ASSEMBLY / REAR
LEVELING SWITCH (CENTER CONSOLE SWITCH PACK)	FC55 / 20-WAY FORD IDC / BLACK	CENTER CONSOLE SWITCH PACK

HARNESS-TO-HARNESS CONNECTORS

Connector	Type / Color	Location / Access
LF60	20-WAY MULTILOCK 070 / WHITE	LEFT HAND 'A' POST CONNECTOR MOUNTING BRACKET / 'A' POST TRIM

GROUNDS

Ground	Location / Type
FC3BR	EYELET (PAIR) - RIGHT HAND LEG / TRANSMISSION TUNNEL, LEFT HAND SIDE
LF1AL	EYELET (PAIR) - LEFT HAND LEG / RIGHT HAND HEADLAMP
LF2BR	EYELET (PAIR) - RIGHT HAND LEG / ENGINE COMPARTMENT, FORWARD OF LEFT HAND HOOD CATCH

REFER TO THE FRONT OF THE BOOK FOR ILLUSTRATIONS DETAILING THE LOCATION AND IDENTIFICATION OF COMPONENTS, RELAYS, CONNECTORS, HARNESES, GROUNDS, VEHICLE CONTROL MODULES AND CONTROL MODULE PINS.

CONTROL MODULE PIN OUT INFORMATION

DRIVER DOOR CONTROL MODULE

Pin	Description	Active	Inactive
I DD10-1	BATTERY POWER SUPPLY	B+	B+
I DD10-8	LOGIC GROUND	GROUND	GROUND
S DD10-9	SCP NETWORK	2 - 1600 Hz	
O DD10-14	DRIVER DOOR PUDDLE LAMP SUPPLY	B+	GROUND
S DD10-16	SCP NETWORK	2 - 1600 Hz	
I DD10-17	POWER GROUND	GROUND	GROUND
I DD11-4	DRIVER DOOR LOCK BARREL UNLOCK REQUEST	B+ (MOMENTARY)	GROUND
I DD11-12	DRIVER DOOR LOCK BARREL LOCK REQUEST	B- (MOMENTARY)	GROUND
I DD11-20	DRIVER DOOR SWITCH	GROUND (DOOR OPEN)	B+

PASSENGER DOOR CONTROL MODULE

Pin	Description	Active	Inactive
I DP10-1	BATTERY POWER SUPPLY	B+	B+
I DP10-8	LOGIC GROUND	GROUND	GROUND
S DP10-9	SCP NETWORK	2 - 1600 Hz	
O DP10-14	PASSENGER DOOR PUDDLE LAMP SUPPLY	B- (LIGHT ON)	GROUND
S DP10-16	SCP NETWORK	2 - 1600 Hz	
I DP10-17	POWER GROUND	GROUND	GROUND
I DP11-20	PASSENGER DOOR SWITCH	GROUND (DOOR OPEN)	B-

BODY PROCESSOR MODULE

Pin	Description	Active	Inactive
I FC14-15	IGNITION SWITCHED GROUND SUPPLY	GROUND	GROUND
O FC14-24	FOOTWELL / INTERIOR LAMP SUPPLY	B+	GROUND
I FC14-32	IGNITION SWITCHED GROUND SUPPLY	GROUND	GROUND
I FC14-41	IGNITION GROUND SUPPLY	GROUND	
J FC14-67	KEY IN IGNITION	GROUND (KEY IN)	B-
O FC14-74	INTERIOR LAMP FADE 2 OUTPUT	B+ (FADES TO 0 V)	B+
I FC14-80	BATTERY POWER SUPPLY (LOGIC)	B+	B+
S FC14-84	SCP NETWORK	2 - 1600 Hz	
S FC14-85	SCP NETWORK	2 - 1600 Hz	
O FC14-101	TRUNK / GLOVE BOX / VANITY LAMP POWER SUPPLY	B+	GROUND
I FC14-104	LIGHTING / MOTORS BATTERY POWER SUPPLY	B+	B+

NOTE: REFER TO THE APPENDIX AT THE REAR OF THIS BOOK FOR CAN AND SCP NETWORK MESSAGES.

The following symbols are used to represent values for Control Module Pin Out data:

I	Input	D	Serial and encoded communications	B+	Battery voltage	KHz	Frequency x 1000
O	Output	C	CAN (Network)	V	Voltage (DC)	MS	Milliseconds
SG	Signal Ground	S	SCP Network	Hz	Frequency	MV	Millivolts

CAUTION: The information on this data page is furnished to aid the user in understanding circuit operation. THIS INFORMATION SHOULD BE USED FOR REFERENCE ONLY.

NOTE: The values listed are approximately those that can be expected at the control module connector pins with all circuit connections made and all components connected and fitted. "Active" means a load is applied or a switch is ON; "Inactive" means a load is not applied or a switch is OFF.

Fig. 10.1

COMPONENTS

Component	Connector / Type / Color	Location / Access
BODY PROCESSOR MODULE	FC14 / 104-WAY AMP EEEC / GREY	PASSENGER SIDE FASCIA / AIRBAG BRACKET
DIODE (BT29) - TRUNK SWITCH	BT29 / DIODE	TRUNK / ADJACENT TO BATTERY
DOOR CONTROL MODULE - DRIVER	DD10 / 22-WAY FORD 2.8 TIMER / BLUE DD11 / 22-WAY FORD 2.8 TIMER / BLACK	DRIVER DOOR / DOOR CASING
DOOR CONTROL MODULE - PASSENGER	DP10 / 22-WAY FORD 2.8 TIMER / BLUE DP11 / 22-WAY FORD 2.8 TIMER / BLACK	PASSENGER DOOR / DOOR CASING
DOOR LOCK SWITCHES - DRIVER	DD3 / 13-WAY ECONOSEAL III LC / BLACK	DRIVER DOOR / DOOR CASING
DOOR SWITCH - DRIVER	DD3 / 13-WAY ECONOSEAL III LC / BLACK	DRIVER DOOR / DOOR CASING
DOOR SWITCH - PASSENGER	DP3 / 13-WAY ECONOSEAL III LC / BLACK	PASSENGER DOOR / DOOR CASING
FOOTWELL LAMP - LH	FC31 / 2-WAY AMP JUNIOR POWER TIMER / BLACK	LEFT HAND FOOTWELL
FOOTWELL LAMP - RH	FC32 / 2-WAY AMP JUNIOR POWER TIMER / BLACK	RIGHT HAND FOOTWELL
GLOVE BOX LAMP	FC33 / 1-WAY LUCAR STRAIGHT FC34 / 1-WAY LUCAR STRAIGHT	GLOVE BOX
IGNITION SWITCH (KEY-IN SWITCH)	FC4 / 8-WAY MULTILOCK 070 / WHITE	STEERING COLUMN
PUDDLE LAMP - DRIVER DOOR	DD14 / 2-WAY AMP JUNIOR POWER TIMER / BLACK	DRIVER DOOR
PUDDLE LAMP - PASSENGER DOOR	DP14 / 2-WAY AMP JUNIOR POWER TIMER / BLACK	PASSENGER DOOR
REAR INTERIOR LAMP (COUPE ONLY)	RH3 / 2-WAY AMP JUNIOR POWER TIMER / WHITE	REAR CENTER OF HEAD LINING
ROOF CONSOLE	RF10 / 6-WAY MULTILOCK 070 / GREY	INTERIOR ROOF
TRUNK LAMP - LH	BT56 / 2-WAY AMP JUNIOR POWER TIMER / WHITE	TRUNK / LEFT HAND SIDE
TRUNK LAMP - RH	BT59 / 2-WAY AMP JUNIOR POWER TIMER / WHITE	TRUNK / RIGHT HAND SIDE
TRUNK SWITCH	BT46 / 2-WAY AUGAT 1.8 / BLACK	TRUNK
VANITY LAMP - LH	RF8 / 3-WAY MULTILOCK 070 / YELLOW	SUN VISOR
VANITY LAMP - RH	RF7 / 3-WAY MULTILOCK 070 / YELLOW	SUN VISOR

HARNESSTO-HARNESSTO CONNECTORS

Connector	Type / Color	Location / Access
BT1	20-WAY MULTILOCK 070 / WHITE	TRUNK / ABOVE RIGHT HAND REAR WHEEL ARCH
DD1	23-WAY AMP - FORD / BLACK	DRIVER SIDE 'A' POST MOUNTING BRACKET / 'A' POST TRIM
DP1	23-WAY AMP - FORD / BLACK	PASSENGER SIDE 'A' POST / 'A' POST TRIM
RF1	18-WAY MULTILOCK 070 / YELLOW	RIGHT HAND 'A' POST CONNECTOR MOUNTING BRACKET / 'A' POST TRIM
RH2	20-WAY MULTILOCK 070 / WHITE	REAR OF CENTER CONSOLE ASSEMBLY

GROUNDS

Ground	Location / Type
BT1AR	EYELET (PAIR) - RIGHT HAND LEG / ADJACENT TO BATTERY
FC2AL	EYELET (PAIR) - LEFT HAND LEG / RIGHT HAND 'A' POST
FC2AR	EYELET (PAIR) - RIGHT HAND LEG / RIGHT HAND 'A' POST
FC2BL	EYELET (PAIR) - LEFT HAND LEG / RIGHT HAND 'A' POST
FC2BR	EYELET (PAIR) - RIGHT HAND LEG / RIGHT HAND 'A' POST
FC3BL	EYELET (PAIR) - LEFT HAND LEG / TRANSMISSION TUNNEL, LEFT HAND SIDE
FC3BR	EYELET (PAIR) - RIGHT HAND LEG / TRANSMISSION TUNNEL, LEFT HAND SIDE
FC4AL	EYELET (PAIR) - LEFT HAND LEG / LEFT HAND 'A' POST
FC4AR	EYELET (PAIR) - RIGHT HAND LEG / LEFT HAND 'A' POST
FC4BL	EYELET (PAIR) - LEFT HAND LEG / LEFT HAND 'A' POST
FC4BR	EYELET (PAIR) - RIGHT HAND LEG / LEFT HAND 'A' POST
RH1S	EYELET (SINGLE) / RIGHT HAND REAR QUARTER

CONTROL MODULE PIN OUT INFORMATION (FOLD OUT PAGE)



REFER TO THE FRONT OF THE BOOK FOR ILLUSTRATIONS DETAILING THE LOCATION AND IDENTIFICATION OF COMPONENTS, RELAYS, CONNECTORS, HARNESSES, GROUNDS, VEHICLE CONTROL MODULES AND CONTROL MODULE PINS.

DATE OF ISSUE: FEBRUARY 1998

CONTROL MODULE PIN OUT INFORMATION

DIMMER MODULE

Pin	Description	Active	Inactive
O FC23-1	MAJOR INSTRUMENT PACK ILLUMINATION BULB SUPPLY	B+ (LIGHTS ON)	GROUND
O FC23-2	MAJOR INSTRUMENT PACK ILLUMINATION BULB SUPPLY	B+ (LIGHTS ON)	GROUND
I FC23-3	IGNITION SWITCHED GROUND SUPPLY	GROUND	GROUND
I FC23-4	SIDE LAMPS ON REQUEST	GROUND	GROUND
I FC23-5	DIMMER POTENTIOMETER FEEDBACK VOLTAGE	1.3 V = DIM; 4 V = BRIGHT	
O FC23-6	DIMMER POTENTIOMETER REFERENCE GROUND	GROUND	GROUND
O FC23-7	GENERAL ILLUMINATION BULB SUPPLY	B+ (LIGHTS ON)	GROUND
O FC23-8	GENERAL ILLUMINATION BULB SUPPLY	B+ (LIGHTS ON)	GROUND
I FC23-9	GROUND SUPPLY	GROUND	GROUND
I FC23-10	BATTERY POWER SUPPLY	B+	B+
I FC23-11	BATTERY POWER SUPPLY	B+	B+
O FC23-12	DIMMER POTENTIOMETER REFERENCE VOLTAGE	4 V	0 V

Fig. 10.2

COMPONENTS

Component	Connector / Type / Color	Location / Access
AIR CONDITIONING CONTROL PANEL	FC43 / 12-WAY MULTILOCK 040 / BLUE	CENTER CONSOLE
CENTER CONSOLE SWITCH PACK	FC55 / 20-WAY FORD IDC / BLACK	CENTER CONSOLE
CIGAR LIGHTER	FC42 / 2-WAY AMP / BLACK FC59 / LUCAR RIGHT ANGLE	FORWARD OF GEAR SELECTOR
CONVERTIBLE TOP SWITCH	FC62 / 10-WAY AMP MQL / BLACK	FORWARD OF GEAR SELECTOR
CRUISE CONTROL ON / OFF SWITCH	FC63 / 10-WAY AMP MQL / NATURAL	REARWARD OF GEAR SELECTOR
DIMMER CONTROL (COLUMN SWITCHGEAR)	SC11 / 6-WAY MULTILOCK 070 / WHITE	STEERING COLUMN COWI
DIMMER MODULE	FC23 / 12-WAY MULTILOCK 040 / BLACK	ADJACENT TO RIGHT HAND FASCIA FUSE BOX
GEAR SELECTOR ILLUMINATION MODULE	FC88 / 10-WAY MULTILOCK 070 / WHITE	FRONT OF GEAR SELECTOR ASSEMBLY
LIGHTING STALK (COLUMN SWITCHGEAR)	SC2 / 10-WAY MULTILOCK 070 / YELLOW	STEERING COLUMN
MAJOR INSTRUMENT PACK	FC25 / 48-WAY AMP PCB SIGNAL / BLACK FC26 / 24-WAY AMP PCB SIGNAL / BLACK	FASCIA
MINOR INSTRUMENT PACK	FC79 / 20-WAY MULTILOCK 040 / BLACK	FASCIA
MODE SWITCH (TRANSMISSION)	FC35 / 10-WAY AMP MQL / BLACK	REARWARD OF GEAR SELECTOR
RADIO	IC10 / 20-WAY MULTILOCK 070 / WHITE	CENTER CONSOLE
SWITCH PACK - DRIVER DOOR	DD17 / 20-WAY MULTILOCK 040 / BLACK	DRIVER DOOR
SWITCH PACK - DRIVER DOOR MEMORY	DD5 / 10-WAY AMP MQL / BLACK	DRIVER DOOR
SWITCH PACK - PASSENGER DOOR	DP17 / 8-WAY MULTILOCK 040 / BLACK	PASSENGER DOOR
TRIP COMPUTER SWITCH PACK	FC27 / 10-WAY AMP MQL / BLACK	FASCIA / DRIVER SIDE
TRUNK AND FUEL FILL RELEASE SWITCH	FC41 / 10-WAY AMP MQL / NATURAL	FASCIA / DRIVER SIDE
VALET SWITCH	FC67 / 10-WAY AMP MQL / BLACK	DRIVER KNEE BOLSTER

HARNESS-TO-HARNESS CONNECTORS

Connector	Type / Color	Location / Access
AC15	20-WAY MULTILOCK 070 / GREY	FASCIA BOTTOM CONNECTOR MOUNTING BRACKET / RIGHT HAND SIDE
DD1	23-WAY AMP - FORD / BLACK	DRIVER SIDE 'A' POST MOUNTING BRACKET / 'A' POST TRIM
DP1	23-WAY AMP - FORD / BLACK	PASSENGER SIDE 'A' POST / 'A' POST TRIM
IC1	20-WAY MULTILOCK 070 / YELLOW	BELOW CENTER CONSOLE GLOVE BOX
SC3	12-WAY MULTILOCK 070 / GREY	RIGHT HAND SIDE OF STEERING COLUMN

GROUNDS

Ground	Location / Type
CE2	EYELET (SINGLE) / ABOVE RIGHT HAND SIDE OF TRANSMISSION TUNNEL
FC2AL	EYELET (PAIR) - LEFT HAND LEG / RIGHT HAND 'A' POST
FC2BL	EYELET (PAIR) - LEFT HAND LEG / RIGHT HAND 'A' POST
FC2BR	EYELET (PAIR) - RIGHT HAND LEG / RIGHT HAND 'A' POST
FC3BL	EYELET (PAIR) - LEFT HAND LEG / TRANSMISSION TUNNEL, LEFT HAND SIDE
FC3BR	EYELET (PAIR) - RIGHT HAND LEG / TRANSMISSION TUNNEL, LEFT HAND SIDE
FC4AL	EYELET (PAIR) - LEFT HAND LEG / LEFT HAND 'A' POST
FC4BL	EYELET (PAIR) - LEFT HAND LEG / LEFT HAND 'A' POST
FC4BR	EYELET (PAIR) - RIGHT HAND LEG / LEFT HAND 'A' POST

CONTROL MODULE PIN OUT INFORMATION (FOLD OUT PAGE)



The following symbols are used to represent values for Control Module Pin Out data:

I	Input	D	Serial and encoded communications	B+	Battery voltage	KHz	Frequency x 1000
O	Output	C	CAN (Network)	V	Voltage (DC)	MS	Milliseconds
SG	Signal Ground	S	SCP Network	Hz	Frequency	MV	Millivolts

CAUTION: The information on this data page is furnished to aid the user in understanding circuit operation. THIS INFORMATION SHOULD BE USED FOR REFERENCE ONLY.

NOTE: The values listed are approximately those that can be expected at the control module connector pins with all circuit connections made and all components connected and fitted. "Active" means a load is applied or a switch is ON; "Inactive" means a load is not applied or a switch is OFF.

REFER TO THE FRONT OF THE BOOK FOR ILLUSTRATIONS DETAILING THE LOCATION AND IDENTIFICATION OF COMPONENTS, RELAYS, CONNECTORS, HARNESSES, GROUNDS, VEHICLE CONTROL MODULES AND CONTROL MODULE PINS.

CONTROL MODULE PIN OUT INFORMATION

POWER ASSISTED STEERING CONTROL MODULE

Pin	Description	Active	Inactive
O FC16-2	TRANSDUCER NEGATIVE	2 V @ IDLE DECREASING WITH VEHICLE SPEED	
I FC16-4	VEHICLE SPEED	B+ @ 10 MPH (16 KM/H) = 20 Hz, 20 MPH (32 KM/H) = 40 Hz	
O FC16-5	TRANSDUCER POSITIVE	9 V @ IDLE INCREASING WITH VEHICLE SPEED	
I FC16-6	IGNITION SWITCHED POWER SUPPLY	B+	0 V
I FC16-8	GROUND	0 V	0 V

Fig. 11.1

COMPONENTS

Component	Connector / Type / Color	Location / Access
POWER ASSISTED STEERING CONTROL MODULE	FC16 / 9-WAY RISTS RELAY / BLACK AND RED	FASCIA / ADJACENT TO RH SIDE FUSE BOX
VARIABLE STEERING CONVERTER - LHD	LL2 / 2-WAY AMP JUNIOR POWER TIMER / BLACK	STEERING RACK / CONTROL VALVE
VARIABLE STEERING CONVERTER - RHD	EM18 / 2-WAY AMP JUNIOR POWER TIMER / BLACK	STEERING RACK / CONTROL VALVE

HARNESSTO-HARNESSTO CONNECTORS

Connector	Type / Color	Location / Access
EM2	18-WAY MULTILOCK 070 / YELLOW	ENGINE COMPARTMENT / ADJACENT TO RIGHT HAND ENCLOSURE
LL1	2-WAY ECONOSEAL III LC / BLACK	ENGINE COMPARTMENT / ADJACENT TO STARTER MOTOR

GROUNDS

Ground	Location / Type
FC2BR	EYELET (PAIR) - RIGHT HAND LEG / RIGHT HAND 'A' POST
FC4BR	EYELET (PAIR) - RIGHT HAND LEG / LEFT HAND 'A' POST

CONTROL MODULE PIN OUT INFORMATION (FOLD OUT PAGE)



The following symbols are used to represent values for Control Module Pin Out data:

I Input	D Serial and encoded communications	B+ Battery voltage	KHz Frequency x 1000
O Output	C CAN (Network)	V Voltage (DC)	MS Milliseconds
SG Signal Ground	S SCP Network	Hz Frequency	MV Millivolts

CAUTION: The information on this data page is furnished to aid the user in understanding circuit operation. THIS INFORMATION SHOULD BE USED FOR REFERENCE ONLY.

NOTE: The values listed are approximately those that can be expected at the control module connector pins with all circuit connections made and all components connected and fitted. "Active" means a load is applied or a switch is ON; "Inactive" means a load is not applied or a switch is OFF.

REFER TO THE FRONT OF THE BOOK FOR ILLUSTRATIONS DETAILING THE LOCATION AND IDENTIFICATION OF COMPONENTS, RELAYS, CONNECTORS, HARNESSES, GROUNDS, VEHICLE CONTROL MODULES AND CONTROL MODULE PINS.

CONTROL MODULE PIN OUT INFORMATION

BODY PROCESSOR MODULE

Pin	Description	Active	Inactive
I FC14-11	AUTO TILT REQUEST	GROUND	B+
I FC14-15	IGNITION SWITCHED GROUND SUPPLY	GROUND	
I FC14-25	COLUMN MOTOR GROUND SUPPLY	GROUND	GROUND
I FC14-32	IGNITION SWITCHED GROUND SUPPLY	GROUND	GROUND
O FC14-40	COLUMN MOTOR POTENTIOMETER REFERENCE VOLTAGE	5 V	
I FC14-41	IGNITION GROUND SUPPLY	GROUND	
O FC14-52	COLUMN REACH MOTOR SUPPLY	B+	GROUND
I FC14-58	NOT-IN-PARK	GROUND (R,N,D,4,3,2)	B- (PARK)
I FC14-66	COLUMN REACH MOTOR POTENTIOMETER FEEDBACK	0.5 V (OUT); 4 V (IN)	
I FC14-67	KEY IN IGNITION	GROUND (KEY IN)	B+
O FC14-78	COLUMN REACH MOTOR SUPPLY	B+	GROUND
I FC14-80	BATTERY POWER SUPPLY (LOGIC)	B+	B-
S FC14-84	SCP NETWORK	2 - 1600 Hz	
S FC14-85	SCP NETWORK	2 - 1600 Hz	
I FC14-87	COLUMN MOVEMENT REQUEST	UP = 10.1 V, DOWN = 12.1 V, RETRACT = 8.5 V, EXTEND = 6.8 V	
O FC14-90	COLUMN TILT MOTOR POTENTIOMETER REFERENCE GROUND	GROUND	GROUND
O FC14-91	COLUMN REACH MOTOR POTENTIOMETER REFERENCE GROUND	GROUND	GROUND
I FC14-93	COLUMN TILT MOTOR POTENTIOMETER FEEDBACK	UP = 4 V, DOWN = 0.5 V	
O FC14-99	COLUMN TILT MOTOR SUPPLY	B+	GROUND
O FC14-100	COLUMN TILT MOTOR SUPPLY	B+	GROUND
I FC14-102	COLUMN MOVEMENT MOTORS BATTERY POWER SUPPLY	B+	

DRIVER DOOR CONTROL MODULE

Pin	Description	Active	Inactive
I DD10-1	BATTERY POWER SUPPLY	B+	B+
I DD10-8	LOGIC GROUND	GROUND	GROUND
S DD10-9	SCP NETWORK	2 - 1600 Hz	
S DD10-16	SCP NETWORK	2 - 1600 Hz	
I DD10-17	POWER GROUND	GROUND	GROUND
O DD11-2	SEAT MEMORY STATUS LED	GROUND (LED ON)	B+
I DD11-6	MEMORY SET REQUEST	B+	
I DD11-20	DRIVER DOOR SWITCH	GROUND (DOOR OPEN)	B+
I DD11-21	MEMORY 1 RECALL REQUEST	B+ (MOMENTARY)	GROUND
I DD11-22	MEMORY 2 RECALL REQUEST	B+ (MOMENTARY)	GROUND

NOTE: REFER TO THE APPENDIX AT THE REAR OF THIS BOOK FOR CAN AND SCP NETWORK MESSAGES.

Fig. 11.2

COMPONENTS

Component	Connector / Type / Color	Location / Access
AUTO TILT SWITCH (COLUMN SWITCHGEAR)	SC9 / 8-WAY GROTE AND HARTMAN MDK / BLACK	STEERING COLUMN / LEFT HAND SIDE
BODY PROCESSOR MODULE	FC14 / 104-WAY AMP EEEEC / GREY	PASSENGER SIDE FASCIA / AIRBAG BRACKET
COLUMN JOY STICK (COLUMN SWITCHGEAR)	SC9 / 8-WAY GROTE AND HARTMAN MDK / BLACK	STEERING COLUMN / LEFT HAND SIDE
DOOR CONTROL MODULE - DRIVER	DD10 / 22-WAY FORD 2.8 TIMER / BLUE DD11 / 22-WAY FORD 2.8 TIMER / BLACK	DRIVER DOOR / DOOR CASING
DOOR SWITCH - DRIVER	DD3 / 13-WAY ECONOSEAL III LC / BLACK	DRIVER DOOR / DOOR CASING
IGNITION SWITCH (KEY-IN SWITCH)	FC4 / 8-WAY MULTILOCK 070 / WHITE	STEERING COLUMN
NOT-IN-PARK MICROSWITCH	FC87 / 3-WAY MULTILOCK 070 / WHITE	GEAR SELECTOR ASSEMBLY
STEERING COLUMN MOTORS	FC60 / 6-WAY MULTILOCK 070 / WHITE FC61 / 8-WAY MULTILOCK 070 / YELLOW	STEERING COLUMN
SWITCH PACK - DRIVER DOOR MEMORY	DD5 / 10-WAY AMP MQL / BLACK	DRIVER DOOR

HARNESS-TO-HARNESS CONNECTORS

Connector	Type / Color	Location / Access
AC14	14-WAY MULTILOCK 070 / GREY	FASCIA BOTTOM CONNECTOR MOUNTING BRACKET / RIGHT HAND SIDE
DD1	23-WAY AMP - FORD / BLACK	DRIVER SIDE 'A' POST MOUNTING BRACKET / 'A' POST TRIM
SC2	10-WAY MULTILOCK 070 / YELLOW	ADJACENT TO STEERING COLUMN MOTOR
SC3	12-WAY MULTILOCK 070 / GREY	RIGHT HAND SIDE OF STEERING COLUMN

GROUNDS

Ground	Location / Type
FC2AR	EYELET (PAIR) - RIGHT HAND LEG / RIGHT HAND 'A' POST
FC2BR	EYELET (PAIR) - RIGHT HAND LEG / RIGHT HAND 'A' POST
FC3BL	EYELET (PAIR) - LEFT HAND LEG / TRANSMISSION TUNNEL, LEFT HAND SIDE
FC3BR	EYELET (PAIR) - RIGHT HAND LEG / TRANSMISSION TUNNEL, LEFT HAND SIDE
FC4AR	EYELET (PAIR) - RIGHT HAND LEG / LEFT HAND 'A' POST
FC4BR	EYELET (PAIR) - RIGHT HAND LEG / LEFT HAND 'A' POST

CONTROL MODULE PIN OUT INFORMATION (FOLD OUT PAGE)



The following symbols are used to represent values for Control Module Pin Out data:

I	Input	D	Serial and encoded communications	B+	Battery voltage	KHz	Frequency x 1000
O	Output	C	CAN (Network)	V	Voltage (DC)	MS	Milliseconds
SG	Signal Ground	S	SCP Network	Hz	Frequency	MV	Millivolts

CAUTION: The information on this data page is furnished to aid the user in understanding circuit operation. THIS INFORMATION SHOULD BE USED FOR REFERENCE ONLY.

NOTE: The values listed are approximately those that can be expected at the control module connector pins with all circuit connections made and all components connected and fitted. "Active" means a load is applied or a switch is ON; "Inactive" means a load is not applied or a switch is OFF.

REFER TO THE FRONT OF THE BOOK FOR ILLUSTRATIONS DETAILING THE LOCATION AND IDENTIFICATION OF COMPONENTS, RELAYS, CONNECTORS, HARNESSSES, GROUNDS, VEHICLE CONTROL MODULES AND CONTROL MODULE PINS.

CONTROL MODULE PIN OUT INFORMATION

BODY PROCESSOR MODULE

Pin	Description	Active	Inactive
I FC14-15	IGNITION SWITCHED GROUND SUPPLY	GROUND	
I FC14-32	IGNITION SWITCHED GROUND SUPPLY	GROUND	GROUND
I FC14-41	IGNITION GROUND SUPPLY	GROUND	
I FC14-58	NOT-IN-PARK	GROUND (R,N,D,4,3,2)	B+ (PARK)
I FC14-80	BATTERY POWER SUPPLY (LOGIC)	B+	B+
S FC14-84	SCP NETWORK	2 - 1600 Hz	
S FC14-85	SCP NETWORK	2 - 1600 Hz	

DRIVER DOOR CONTROL MODULE

Pin	Description	Active	Inactive
I DD10-1	BATTERY POWER SUPPLY	B+	B+
O DD10-2	DRIVER DOOR MIRROR VERTICAL / HORIZONTAL MOTOR COMMON SUPPLY	B+ = LEFT / DOWN; GROUND = RIGHT / UP	
O DD10-3	DRIVER DOOR MIRROR HORIZONTAL MOVEMENT MOTOR	B+ = RIGHT	GROUND = LEFT
O DD10-4	DRIVER DOOR MIRROR VERTICAL MOVEMENT MOTOR	B+ = UP	GROUND = DOWN
I DD10-8	LOGIC GROUND	GROUND	GROUND
S DD10-9	SCP NETWORK	2 - 1600 Hz	
S DD10-16	SCP NETWORK	2 - 1600 Hz	
I DD10-17	POWER GROUND	GROUND	GROUND
O DD10-20	DRIVER DOOR MIRROR POTENTIOMETER COMMON REFERENCE VOLTAGE	B+	B+
I DD10-21	DRIVER DOOR MIRROR POTENTIOMETER HORIZONTAL POSITION FEEDBACK	1 V = LEFT; 8 V = RIGHT	
I DD10-22	DRIVER DOOR MIRROR POTENTIOMETER VERTICAL POSITION FEEDBACK	1 V = DOWN; 8 V = UP	
I DD11-1	MIRROR SELECT	B+ = UP / RIGHT	GROUND = DOWN / LEFT
O DD11-2	SEAT MEMORY STATUS LED	GROUND (I.F.D.N)	B+
I DD11-3	RH VERTICAL MOVEMENT REQUEST	B+ = DOWN	GROUND = UP
I DD11-6	MEMORY SET REQUEST	B+	
I DD11-9	RH HORIZONTAL MOVEMENT REQUEST	B+ = LEFT	GROUND = RIGHT
I DD11-10	LH HORIZONTAL MOVEMENT REQUEST	B+ = LEFT	GROUND = RIGHT
I DD11-17	LH VERTICAL MOVEMENT REQUEST	B+ = DOWN	GROUND = UP
I DD11-20	DRIVER DOOR SWITCH	GROUND (DOOR OPEN)	B+
I DD11-21	MEMORY 1 RECALL REQUEST	B- (MOMENTARY)	GROUND
I DD11-22	MEMORY 2 RECALL REQUEST	B- (MOMENTARY)	GROUND

MAJOR INSTRUMENT PACK

Pin	Description	Active	Inactive
S FC25-19	SCP NETWORK	2 - 1600 Hz	
S FC25-20	SCP NETWORK	2 - 1600 Hz	
C FC25-24	CAN NETWORK	15 - 1500 Hz	
C FC25-47	CAN NETWORK	15 - 1500 Hz	

PASSENGER DOOR CONTROL MODULE

Pin	Description	Active	Inactive
I DP10-1	BATTERY POWER SUPPLY	B+	B+
O DP10-2	PASSENGER DOOR MIRROR VERTICAL / HORIZONTAL MOVEMENT MOTORS COMMON	B+ = LEFT / DOWN	GROUND = RIGHT / UP
O DP10-3	PASSENGER DOOR MIRROR HORIZONTAL MOVEMENT MOTOR	B+ = RIGHT	GROUND
O DP10-4	PASSENGER DOOR MIRROR VERTICAL MOVEMENT MOTOR	B+ = UP	GROUND
I DP10-8	LOGIC GROUND	GROUND	GROUND
S DP10-9	SCP NETWORK	2 - 1600 Hz	
S DP10-16	SCP NETWORK	2 - 1600 Hz	
I DP10-17	POWER GROUND	GROUND	GROUND
O DP10-20	PASSENGER DOOR MIRROR POTENTIOMETER COMMON REFERENCE VOLTAGE	B+	B+
I DP10-21	PASSENGER DOOR MIRROR POTENTIOMETER HORIZONTAL POSITION FEEDBACK VOLTAGE	1 V = LEFT; 8 V = RIGHT	
I DP10-22	PASSENGER DOOR MIRROR POTENTIOMETER VERTICAL POSITION FEEDBACK VOLTAGE	1 V = DOWN; 8 V = UP	

NOTE: REFER TO THE APPENDIX AT THE REAR OF THIS BOOK FOR CAN AND SCP NETWORK MESSAGES.

The following symbols are used to represent values for Control Module Pin Out data:

I Input	D Serial and encoded communications	B+ Battery voltage	KHz Frequency x 1000
O Output	C CAN (Network)	V Voltage (DC)	MS Milliseconds
SG Signal Ground	S SCP Network	Hz Frequency	MV Millivolts

CAUTION: The information on this data page is furnished to aid the user in understanding circuit operation. THIS INFORMATION SHOULD BE USED FOR REFERENCE ONLY.

NOTE: The values listed are approximately those that can be expected at the control module connector pins with all circuit connections made and all components connected and fitted. "Active" means a load is applied or a switch is ON; "Inactive" means a load is not applied or a switch is OFF.

Fig. 11.3

COMPONENTS

Component	Connector / Type / Color	Location / Access
BODY PROCESSOR MODULE	FC14 / 104-WAY AMP EEEC / GREY	PASSENGER SIDE FASCIA / AIRBAG BRACKET
DOOR CONTROL MODULE - DRIVER	DD10 / 22-WAY FORD 2.8 TIMER / BLUE DD11 / 22-WAY FORD 2.8 TIMER / BLACK	DRIVER DOOR / DOOR CASING
DOOR CONTROL MODULE - PASSENGER	DP10 / 22-WAY FORD 2.8 TIMER / BLUE DP11 / 22-WAY FORD 2.8 TIMER / BLACK	PASSENGER DOOR / DOOR CASING
DOOR MIRROR MOTORS - DRIVER	DD8 / 12-WAY MULTILOCK 040 / BLUE	DRIVER DOOR
DOOR MIRROR MOTORS - PASSENGER	DP8 / 12-WAY MULTILOCK 040 / BLUE	PASSENGER DOOR
DOOR SWITCH - DRIVER	DD3 / 13-WAY ECONOSEAL III LC / BLACK	DRIVER DOOR / DOOR CASING
MAJOR INSTRUMENT PACK	FC25 / 48-WAY AMP PCB SIGNAL / BLACK FC26 / 24-WAY AMP PCB SIGNAL / BLACK	FASCIA
MIRROR JOYSTICK (DRIVER DOOR SWITCH PACK)	DD17 / 20-WAY MULTILOCK 040 / BLACK	DRIVER DOOR SWITCH PACK
NOT-IN-PARK MICROSWITCH	FC87 / 3-WAY MULTILOCK 070 / WHITE	GEAR SELECTOR ASSEMBLY
SWITCH PACK - DRIVER DOOR MEMORY	DD6 / 10-WAY AMP MQL / BLACK	DRIVER DOOR

HARNESS-TO-HARNESS CONNECTORS

Connector	Type / Color	Location / Access
AC14	14-WAY MULTILOCK 070 / GREY	FASCIA BOTTOM CONNECTOR MOUNTING BRACKET / RIGHT HAND SIDE
DD1	23-WAY AMP - FORD / BLACK	DRIVER SIDE 'A' POST MOUNTING BRACKET / 'A' POST TRIM
DP1	23-WAY AMP - FORD / BLACK	PASSENGER SIDE 'A' POST / 'A' POST TRIM

GROUNDS

Ground	Location / Type
FC2AR	EYELET (PAIR) - RIGHT HAND LEG / RIGHT HAND 'A' POST
FC3AS	EYELET (SINGLE) / TRANSMISSION TUNNEL, LEFT HAND SIDE
FC3BR	EYELET (PAIR) - RIGHT HAND LEG / TRANSMISSION TUNNEL, LEFT HAND SIDE
FC4AR	EYELET (PAIR) - RIGHT HAND LEG / LEFT HAND 'A' POST

CONTROL MODULE PIN OUT INFORMATION (FOLD OUT PAGE)



CONTROL MODULE PIN OUT INFORMATION

BODY PROCESSOR MODULE

Pin	Description	Active	Inactive
I FC14-15	IGNITION SWITCHED GROUND SUPPLY	GROUND	
I FC14-16	SIDE LAMP REQUEST	GROUND	B+
I FC14-42	DIPPED BEAM REQUEST	GROUND	B+
I FC14-79	BATTERY POWER SUPPLY	GROUND	B+
I FC14-80	BATTERY POWER SUPPLY (LOGIC)	B+	B+
S FC14-84	SCP NETWORK	2 - 1600 Hz	
S FC14-85	SCP NETWORK	2 - 1600 Hz	

DRIVER DOOR CONTROL MODULE

Pin	Description	Active	Inactive
I DD10-1	BATTERY POWER SUPPLY	B+	
I DD10-8	LOGIC GROUND	GROUND	
S DD10-9	SCP NETWORK	2 - 1600 Hz	
S DD10-16	SCP NETWORK	2 - 1600 Hz	
I DD11-15	DOOR MIRROR POWER FOLD BACK REQUEST	B+	GROUND

DRIVER SEAT CONTROL MODULE

Pin	Description	Active	Inactive
O SD3-4	DOOR MIRROR FOLD BACK ACTIVATE	GROUND	B+
I SD5-2	POWER GROUND	GROUND	GROUND
I SD5-5	BATTERY POWER SUPPLY	B+	B+
S SD5-9	SCP NETWORK	2 - 1600 Hz	
S SD5-10	SCP NETWORK	2 - 1600 Hz	

MAJOR INSTRUMENT PACK

Pin	Description	Active	Inactive
S FC25-19	SCP NETWORK	2 - 1600 Hz	
S FC25-20	SCP NETWORK	2 - 1600 Hz	
C FC25-24	CAN NETWORK	15 - 1500 Hz	
C FC25-47	CAN NETWORK	15 - 1500 Hz	

PASSENGER SEAT CONTROL MODULE

Pin	Description	Active	Inactive
O SP3-4	DOOR MIRROR FOLD OUT ACTIVATE	GROUND	
I SP5-2	POWER GROUND	GROUND	GROUND
I SP5-5	BATTERY POWER SUPPLY	B+	B+
S SP5-9	SCP NETWORK	2 - 1600 Hz	
S SP5-10	SCP NETWORK	2 - 1600 Hz	

SECURITY AND LOCKING CONTROL MODULE

Pin	Description	Active	Inactive
O BT40-5	REVERSE LAMP SUPPLY	B+	GROUND
I BT40-6	BATTERY POWER SUPPLY	B+	B+
S BT40-8	SCP NETWORK	2 - 1600 Hz	
I BT40-13	GROUND	GROUND	GROUND
I BT40-14	GROUND	GROUND	GROUND
S BT40-16	SCP NETWORK	2 - 1600 Hz	

NOTE: REFER TO THE APPENDIX AT THE REAR OF THIS BOOK FOR CAN AND SCP NETWORK MESSAGES.

The following symbols are used to represent values for Control Module Pin Out data:

I Input	D Serial and encoded communications	B+ Battery voltage	KHz Frequency x 1000
O Output	C CAN (Network)	V Voltage (DC)	MS Milliseconds
SG Signal Ground	S SCP Network	Hz Frequency	MV Millivolts

CAUTION: The information on this data page is furnished to aid the user in understanding circuit operation. THIS INFORMATION SHOULD BE USED FOR REFERENCE ONLY.

NOTE: The values listed are approximately those that can be expected at the control module connector pins with all circuit connections made and all components connected and fitted. "Active" means a load is applied or a switch is ON; "Inactive" means a load is not applied or a switch is OFF.

Fig. 11.4

COMPONENTS

Component	Connector / Type / Color	Location / Access
BODY PROCESSOR MODULE	FC14 / 104-WAY AMP EEEC / GREY	PASSENGER SIDE FASCIA / AIRBAG BRACKET
DOOR CONTROL MODULE - DRIVER	DD10 / 22-WAY FORD 2.8 TIMER / BLUE DD11 / 22-WAY FORD 2.8 TIMER / BLACK	DRIVER DOOR / DOOR CASING
DOOR MIRROR - DRIVER	DD8 / 12-WAY MULTILOCK 040 / BLUE	DRIVER DOOR
DOOR MIRROR - PASSENGER	DP8 / 12-WAY MULTILOCK 040 / BLUE	PASSENGER DOOR
INTERIOR REAR VIEW MIRROR	RF2 / 6-WAY MULTILOCK 070 / YELLOW	WINDSHIELD / FORWARD OF ROOF CONSOLE
LIGHTING STALK (COLUMN SWITCHGEAR)	SC2 / 10-WAY MULTILOCK 070 / YELLOW	STEERING COLUMN
MAJOR INSTRUMENT PACK	FC25 / 48-WAY AMP PCB SIGNAL / BLACK FC26 / 24-WAY AMP PCB SIGNAL / BLACK	FASCIA
MIRROR JOY STICK (DRIVER DOOR SWITCH PACK)	DD17 / 20-WAY MULTILOCK 040 / BLACK	DRIVER DOOR SWITCH PACK
SEAT CONTROL MODULE - DRIVER	SD3 / 16-WAY FORD 2.8 TIMER / BLACK SD4 / 26-WAY FORD IDC / BLACK SD5 / 10-WAY FORD 2.8 TIMER / BLACK	BELOW SEAT CUSHION
SEAT CONTROL MODULE - PASSENGER	SP3 / 16-WAY FORD 2.8 TIMER / BLACK SP5 / 10-WAY FORD 2.8 TIMER / BLACK	BELOW SEAT CUSHION
SECURITY AND LOCKING CONTROL MODULE	BT40 / 16-WAY FORD 2.8 TIMER / BLACK BT41 / 26-WAY FORD IDC / BLACK RH20 / COAXIAL CONNECTOR	TRUNK / ELECTRICAL CARRIER

HARNESS-TO-HARNESS CONNECTORS

Connector	Type / Color	Location / Access
AC13	20-WAY MULTILOCK 070 / YELLOW	FASCIA BOTTOM CONNECTOR MOUNTING BRACKET / RIGHT HAND SIDE
AC14	14-WAY MULTILOCK 070 / GREY	FASCIA BOTTOM CONNECTOR MOUNTING BRACKET / RIGHT HAND SIDE
AC16	6-WAY MULTILOCK 070 / YELLOW	LEFT HAND 'A' POST CONNECTOR MOUNTING BRACKET / 'A' POST TRIM
BT1	20-WAY MULTILOCK 070 / WHITE	TRUNK / ABOVE RIGHT HAND REAR WHEEL ARCH
DD1	23-WAY AMP - FORD / BLACK	DRIVER SIDE 'A' POST MOUNTING BRACKET / 'A' POST TRIM
DP1	23-WAY AMP - FORD / BLACK	PASSENGER SIDE 'A' POST / 'A' POST TRIM
RF1	18-WAY MULTILOCK 070 / YELLOW	RIGHT HAND 'A' POST CONNECTOR MOUNTING BRACKET / 'A' POST TRIM
RH12	18-WAY MULTILOCK 070 / YELLOW	REAR OF CENTER CONSOLE ASSEMBLY
RH2	20-WAY MULTILOCK 070 / WHITE	REAR OF CENTER CONSOLE ASSEMBLY
SD1	8-WAY MULTILOCK 070 / YELLOW	BELOW DRIVER SEAT
SP1	8-WAY MULTILOCK 070 / YELLOW	BELOW PASSENGER SEAT

GROUNDS

Ground	Location / Type
BT1AR	EYELET (PAIR) - RIGHT HAND LEG / ADJACENT TO BATTERY
FC2AR	EYELET (PAIR) - RIGHT HAND LEG / RIGHT HAND 'A' POST
FC3BL	EYELET (PAIR) - LEFT HAND LEG / TRANSMISSION TUNNEL, LEFT HAND SIDE
FC3BR	EYELET (PAIR) - RIGHT HAND LEG / TRANSMISSION TUNNEL, LEFT HAND SIDE
FC4AR	EYELET (PAIR) - RIGHT HAND LEG / LEFT HAND 'A' POST
FC5L	EYELET (PAIR) - LEFT HAND LEG / RIGHT HAND SEAT
FC5S	EYELET (SINGLE) / RIGHT HAND SEAT
FC6L	EYELET (PAIR) - LEFT HAND LEG / LEFT HAND SEAT
FC6S	EYELET (SINGLE) / LEFT HAND SEAT

CONTROL MODULE PIN OUT INFORMATION (FOLD OUT PAGE)



CONTROL MODULE PIN OUT INFORMATION

ADAPTIVE DAMPING CONTROL MODULE

Pin	Description	Active	Inactive
O BT69-1	MAJOR INSTRUMENT PACK ADAPTIVE DAMPING MIL		B+
O BT69-3	ACCELEROMETER COMMON GROUND SUPPLY	GROUND	GROUND
D BT69-10	SERIAL COMMUNICATIONS		
I BT69-11	IGNITION SWITCHED POWER SUPPLY	B+	GROUND
O BT69-13	LH REAR DAMPER BATTERY POWER SUPPLY	B+	B+
O BT69-14	RH FRONT DAMPER BATTERY POWER SUPPLY	B+	B+
O BT69-15	RH REAR DAMPER BATTERY POWER SUPPLY	B+	B+
I BT69-18	GROUND	GROUND	GROUND
I BT69-20	FRONT LATERAL ACCELEROMETER FEEDBACK	< 0.2 V OR > 4.8 V	2.3 - 2.7 V = HARD
I BT69-21	FRONT VERTICAL ACCELEROMETER FEEDBACK	< 0.2 V OR > 4.8 V	2.3 - 2.7 V = HARD
I BT69-22	REAR VERTICAL ACCELEROMETER FEEDBACK	< 0.2 V OR > 4.8 V	2.3 - 2.7 V = HARD
O BT69-24	VEHICLE SPEED SIGNAL	22 Hz @ 10 MPH (16 KM/H); 44 Hz @ 20 MPH (32 KM/H) @ B+	
O BT69-25	ACCELEROMETER COMMON VOLTAGE SUPPLY	5 V	5 V
I BT69-26	BRAKE SWITCH	GROUND	B-
I BT69-27	BATTERY POWER SUPPLY	B+	B-
D BT69-28	SERIAL COMMUNICATIONS		
O BT69-30	LH FRONT DAMPER BATTERY POWER SUPPLY	B+	B-
O BT69-31	LH FRONT DAMPER	GROUND	B-
O BT69-32	LH REAR DAMPER	GROUND	B-
O BT69-33	RH FRONT DAMPER	GROUND	B-
O BT69-34	RH REAR DAMPER	GROUND	B-

Fig. 11.5

COMPONENTS

Component	Connector / Type / Color	Location / Access
ACCELEROMETER - FRONT LATERAL	EM59 / 3-WAY AMP MQL / BLACK	ENGINE COMPARTMENT / ADJACENT TO ECM
ACCELEROMETER - REAR VERTICAL	BT52 / 3-WAY AMP MQL / BLACK	TRUNK / BELOW FUEL TANK
ACCELEROMETER - FRONT VERTICAL	FC7 / 3-WAY AMP MQL / BLACK	CENTER CONSOLE / BEHIND ICE HEAD UNIT
ADAPTIVE DAMPING CONTROL MODULE	BT69 / 35-WAY AMP JUNIOR POWER TIMER / BLACK	TRUNK / ADJACENT TO ELECTRICAL CARRIER
BRAKE SWITCH	AC24 / 4-WAY MULTILOCK 070 / WHITE	TOP OF BRAKE PEDAL
DAMPER SOLENOID - LH FRONT	LF43 / 2-WAY DELPHI/REINSHAGEN / BLACK	TOP OF LEFT HAND FRONT DAMPER
DAMPER SOLENOID - LH REAR	RL2 / 2-WAY DELPHI/REINSHAGEN / GREY	TOP OF LEFT HAND REAR DAMPER
DAMPER SOLENOID - RH FRONT	LF44 / 2-WAY DELPHI/REINSHAGEN / BLACK	TOP OF RIGHT HAND FRONT DAMPER
DAMPER SOLENOID - RH REAR	RR2 / 2-WAY DELPHI/REINSHAGEN / GREY	TOP OF RIGHT HAND REAR DAMPER

HARNESSTO-HARNESSTO CONNECTORS

Connector	Type / Color	Location / Access
AC13	20-WAY MULTILOCK 070 / YELLOW	FASCIA BOTTOM CONNECTOR MOUNTING BRACKET / RIGHT HAND SIDE
BT1	20-WAY MULTILOCK 070 / WHITE	TRUNK / ABOVE RIGHT HAND REAR WHEEL ARCH
BT3	18-WAY MULTILOCK 070 / YELLOW	TRUNK / ABOVE RIGHT HAND REAR WHEEL ARCH
BT72	2-WAY ECONOSEAL III LC / BLACK	TRUNK / BELOW FUEL TANK
BT73	2-WAY ECONOSEAL III LC / BLACK	TRUNK / BELOW FUEL TANK
EM3	14-WAY MULTILOCK 070 / GREY	ENGINE COMPARTMENT / ADJACENT TO RIGHT HAND ENCLOSURE
LF1	20-WAY MULTILOCK 070 / GREY	LEFT HAND 'A' POST CONNECTOR MOUNTING BRACKET / 'A' POST TRIM
LF60	20-WAY MULTILOCK 070 / WHITE	LEFT HAND 'A' POST CONNECTOR MOUNTING BRACKET / 'A' POST TRIM
RH1	20-WAY MULTILOCK 070 / GREY	BEHIND GLOVE BOX
RH12	18-WAY MULTILOCK 070 / YELLOW	REAR OF CENTER CONSOLE ASSEMBLY
RL3	2-WAY AUGAT 1.6 / BLACK	REAR OF REAR HUB ASSEMBLY / LEFT HAND SIDE
RR3	2-WAY AUGAT 1.6 / BLACK	REAR OF REAR HUB ASSEMBLY / RIGHT HAND SIDE

GROUNDS

Ground	Location / Type
BT2BL	EYELET (PAIR) - LEFT HAND LEG / TRUNK, RIGHT REAR

CONTROL MODULE PIN OUT INFORMATION (FOLD OUT PAGE)



The following symbols are used to represent values for Control Module Pin Out data:

I Input	D Serial and encoded communications	B+ Battery voltage	KHz Frequency x 1000
O Output	C CAN (Network)	V Voltage (DC)	MS Milliseconds
SG Signal Ground	S SCP Network	Hz Frequency	MV Millivolts

CAUTION: The information on this data page is furnished to aid the user in understanding circuit operation. THIS INFORMATION SHOULD BE USED FOR REFERENCE ONLY.

NOTE: The values listed are approximately those that can be expected at the control module connector pins with all circuit connections made and all components connected and fitted. "Active" means a load is applied or a switch is ON; "Inactive" means a load is not applied or a switch is OFF.

REFER TO THE FRONT OF THE BOOK FOR ILLUSTRATIONS DETAILING THE LOCATION AND IDENTIFICATION OF COMPONENTS, RELAYS, CONNECTORS, HARNESSES, GROUNDS, VEHICLE CONTROL MODULES AND CONTROL MODULE PINS.

CONTROL MODULE PIN OUT INFORMATION

BODY PROCESSOR MODULE

Pin	Description	Active	Inactive
I FC14-16	IGNITION SWITCHED GROUND SUPPLY	GROUND	
O FC14-17	LHD RH (RHD LH) SEAT HEATER STATE LED	GROUND (LED ON)	B+
I FC14-32	IGNITION SWITCHED GROUND SUPPLY	GROUND	GROUND
I FC14-36	LHD RH (RHD LH) SEAT HEATER REQUEST	GROUND	B-
I FC14-41	IGNITION GROUND SUPPLY	GROUND	
O FC14-69	LHD LH SEAT HEATER STATUS LED (RHD = RH)	GROUND	B+
I FC14-80	BATTERY POWER SUPPLY (LOGIC)	B+	B-
S FC14-84	SCP NETWORK	2 - 1600 Hz	
S FC14-85	SCP NETWORK	2 - 1600 Hz	
I FC14-86	LHD LH (RHD RH) SEAT HEATER REQUEST	GROUND (MOMENTARY)	B-

DRIVER DOOR CONTROL MODULE

Pin	Description	Active	Inactive
I DD10-1	BATTERY POWER SUPPLY	B+	B-
I DD10-8	LOGIC GROUND	GROUND	GROUND
S DD10-9	SCP NETWORK	2 - 1600 Hz	
S DD10-16	SCP NETWORK	2 - 1600 Hz	
I DD10-17	POWER GROUND	GROUND	GROUND
O DD11-2	SEAT MEMORY STATUS LED	GROUND (LED ON)	B-
I DD11-6	MEMORY SET REQUEST	B+	GROUND
I DD11-21	MEMORY 1 RECALL REQUEST	B+ (MOMENTARY)	GROUND
I DD11-22	MEMORY 2 RECALL REQUEST	B+ (MOMENTARY)	GROUND

DRIVER SEAT CONTROL MODULE

Pin	Description	Active	Inactive
O SD3-1	DRIVER SEAT SQUAB MOTOR SUPPLY - FORWARD	B-	GROUND
O SD3-2	DRIVER SEAT SQUAB MOTOR SUPPLY - REAR	B+	GROUND
O SD3-3	DRIVER SEAT HEATER ELEMENTS SUPPLY	B+	GROUND
O SD3-5	DRIVER SEAT LUMBAR PUMP INFLATE MOTOR	B+	GROUND
O SD3-6	DRIVER SEAT LUMBAR PUMP DEFLATE SOLENOID	B+	GROUND
O SD3-7	DRIVER SEAT FORE / AFT MOTOR SUPPLY	B+	GROUND
O SD3-8	DRIVER SEAT FORE / AFT MOTOR SUPPLY	B+	GROUND
I SD3-9	DRIVER SEAT FORE MOVEMENT REQUEST	B+ (MOMENTARY)	GROUND
I SD3-10	DRIVER SEAT AFT MOVEMENT REQUEST	B+ (MOMENTARY)	GROUND
I SD3-11	DRIVER SEAT CUSHION REAR EDGE LOWER REQUEST	B+ (MOMENTARY)	GROUND
I SD3-12	DRIVER SEAT CUSHION REAR EDGE RAISE REQUEST	B+ (MOMENTARY)	GROUND
I SD3-13	DRIVER SEAT LUMBAR INFLATE REQUEST	B+ (MOMENTARY)	GROUND
I SD3-14	DRIVER SEAT LUMBAR DEFLATE REQUEST	B+ (MOMENTARY)	GROUND
I SD3-15	DRIVER SEAT SQUAB AFT RECLINE REQUEST	B+ (MOMENTARY)	GROUND
I SD3-16	DRIVER SEAT SQUAB FORE RECLINE REQUEST	B+ (MOMENTARY)	GROUND
O SD4-1	DRIVER SEAT SQUAB POTENTIOMETER REFERENCE GROUND	GROUND	GROUND
O SD4-2	DRIVER SEAT FORE / AFT MOVEMENT POTENTIOMETER REFERENCE GROUND	GROUND	GROUND
O SD4-5	DRIVER SEAT SQUAB POT. REFERENCE VOLTAGE	B+	B+
O SD4-6	DRIVER SEAT RAISE / LOWER POTENTIOMETER REFERENCE VOLTAGE	B+	B+
I SD4-10	DRIVER SEAT RAISE / LOWER POTENTIOMETER FEEDBACK	10 V = UP; 2 V = DOWN	
I SD4-11	DRIVER SEAT SQUAB POT. FEEDBACK	9 V = UP; 4 V = DOWN	
I SD4-12	DRIVER SEAT FORE / AFT POTENTIOMETER FEEDBACK	10 V = FORWARD; 2 V = REAR	
O SD4-14	DRIVER SEAT RAISE / LOWER POTENTIOMETER REFERENCE GROUND	GROUND	GROUND
O SD4-18	DRIVER SEAT FORE / AFT MOVEMENT POTENTIOMETER REFERENCE VOLTAGE	B+	B+
I SD5-1	DRIVER OR PASSENGER SEAT IDENTIFICATION	GROUND (DRIVER)	
I SD5-2	POWER GROUND	GROUND	GROUND
O SD5-3	DRIVER SEAT RAISE / LOWER MOTOR SUPPLY	B+	GROUND
O SD5-4	DRIVER SEAT RAISE / LOWER MOTOR SUPPLY	B+	GROUND
I SD5-5	BATTERY POWER SUPPLY	B+	B+
I SD5-8	DRIVER SEAT BELT FASTENED	B+ (FASTENED)	GROUND
S SD5-9	SCP NETWORK	2 - 1600 Hz	
S SD5-10	SCP NETWORK	2 - 1600 Hz	

MAJOR INSTRUMENT PACK

Pin	Description	Active	Inactive
S FC25-19	SCP NETWORK	2 - 1600 Hz	
S FC25-20	SCP NETWORK	2 - 1600 Hz	
C FC25-24	CAN NETWORK	15 - 1500 Hz	
C FC25-47	CAN NETWORK	15 - 1500 Hz	

NOTE: REFER TO THE APPENDIX AT THE REAR OF THIS BOOK FOR CAN AND SCP NETWORK MESSAGES.

The following symbols are used to represent values for Control Module Pin Out data:

I Input	D Serial and encoded communications	B+ Battery voltage	KHz Frequency x 1000
O Output	C CAN (Network)	V Voltage (DC)	MS Milliseconds
SG Signal Ground	S SCP Network	Hz Frequency	MV Millivolts

CAUTION: The information on this data page is furnished to aid the user in understanding circuit operation. THIS INFORMATION SHOULD BE USED FOR REFERENCE ONLY.

NOTE: The values listed are approximately those that can be expected at the control module connector pins with all circuit connections made and all components connected and fitted. "Active" means a load is applied or a switch is ON; "Inactive" means a load is not applied or a switch is OFF.

Fig. 12.1

COMPONENTS

Component	Connector / Type / Color	Location / Access
BODY PROCESSOR MODULE	FC14 / 104-WAY AMP EEEC / GREY	PASSENGER SIDE FASCIA / AIRBAG BRACKET
DOOR CONTROL MODULE - DRIVER	DD10 / 22-WAY FORD 2.8 TIMER / BLUE DD11 / 22-WAY FORD 2.8 TIMER / BLACK	DRIVER DOOR / DOOR CASING
MAJOR INSTRUMENT PACK	FC25 / 48-WAY AMP PCB SIGNAL / BLACK FC26 / 24-WAY AMP PCB SIGNAL / BLACK	FASCIA
SEAT BELT SWITCH	SD20 / 2-WAY MULTILOCK 040 / BLACK	BELOW SEAT CUSHION
SEAT CONTROL MODULE - DRIVER	SD3 / 16-WAY FORD 2.8 TIMER / BLACK SD4 / 26-WAY FORD IDC / BLACK SD5 / 10-WAY FORD 2.8 TIMER / BLACK	BELOW SEAT CUSHION
SEAT CUSHION (HEATER) - DRIVER	SD19 / 3-WAY MULTILOCK 070 / YELLOW	SEAT CUSHION
SEAT HEATER SWITCH (CENTER CONSOLE SWITCH PACK)	FC55 / 20-WAY FORD IDC / BLACK	CENTER CONSOLE SWITCH PACK
SEAT LUMBAR PUMP - DRIVER	SD14 / 3-WAY MULTILOCK 070 / YELLOW	SEAT BACK
SEAT MOTORS - DRIVER	SD7 / 6-WAY MULTILOCK 070 / WHITE SD8 / 6-WAY MULTILOCK 070 / WHITE SD9 / 6-WAY MULTILOCK 070 / YELLOW	BELOW SEAT CUSHION
SQUAB (HEATER) - DRIVER	SD17 / 3-WAY MULTILOCK 070 / GREY	SEAT SQUAB
SWITCH PACK - DRIVER DOOR MEMORY	DD5 / 10-WAY AMP MQL / BLACK	DRIVER DOOR
SWITCH PACK - DRIVER SEAT	SD11 / 16-WAY MULTILOCK 040 / BLACK	DRIVER SEAT

HARNESSTO-HARNESSTO CONNECTORS

Connector	Type / Color	Location / Access
AC14	14-WAY MULTILOCK 070 / GREY	FASCIA BOTTOM CONNECTOR MOUNTING BRACKET / RIGHT HAND SIDE
DD1	23-WAY AMP - FORD / BLACK	DRIVER SIDE 'A' POST MOUNTING BRACKET / 'A' POST TRIM
SD1	8-WAY MULTILOCK 070 / YELLOW	BELOW DRIVER SEAT

GROUNDS

Ground	Location / Type
FC2AR	EYELET (PAIR) - RIGHT HAND LEG / RIGHT HAND 'A' POST
FC3BR	EYELET (PAIR) - RIGHT HAND LEG / TRANSMISSION TUNNEL, LEFT HAND SIDE
FC4AR	EYELET (PAIR) - RIGHT HAND LEG / LEFT HAND 'A' POST
FC5L	EYELET (PAIR) - LEFT HAND LEG / RIGHT HAND SEAT
FC5R	EYELET (PAIR) - RIGHT HAND LEG / RIGHT HAND SEAT
FC6L	EYELET (PAIR) - LEFT HAND LEG / LEFT HAND SEAT
FC6R	EYELET (PAIR) - RIGHT HAND LEG / LEFT HAND SEAT

CONTROL MODULE PIN OUT INFORMATION (FOLD OUT PAGE)



REFER TO THE FRONT OF THE BOOK FOR ILLUSTRATIONS DETAILING THE LOCATION AND IDENTIFICATION OF COMPONENTS, RELAYS, CONNECTORS, HARNESSES, GROUNDS, VEHICLE CONTROL MODULES AND CONTROL MODULE PINS.

DATE OF ISSUE: FEBRUARY 1998

CONTROL MODULE PIN OUT INFORMATION

BODY PROCESSOR MODULE

Pin	Description	Active	Inactive
I FC14-15	IGNITION SWITCHED GROUND SUPPLY	GROUND	
O FC14-17	LHD RH (RHD LH) SEAT HEATER STATE LED	GROUND (LED ON)	B-
I FC14-32	IGNITION SWITCHED GROUND SUPPLY	GROUND	GROUND
I FC14-35	LHD RH (RHD LH) SEAT HEATER REQUEST	GROUND	B+
O FC14-69	LHD LH SEAT HEATER STATUS LED (RHD = RH)	GROUND	B-
I FC14-80	BATTERY POWER SUPPLY (LOGIC)	B+	B-
S FC14-84	SCP NETWORK	2 - 1600 Hz	
S FC14-85	SCP NETWORK	2 - 1600 Hz	
I FC14-86	LHD LH (RHD RH) SEAT HEATER REQUEST	GROUND (MOMENTARY)	B-

DRIVER SEAT CONTROL MODULE

Pin	Description	Active	Inactive
O SD3-1	DRIVER SEAT SQUAB MOTOR SUPPLY - FORWARD	B+	GROUND
O SD3-2	DRIVER SEAT SQUAB MOTOR SUPPLY - REAR	B+	GROUND
O SD3-3	DRIVER SEAT HEATER ELEMENTS SUPPLY	B+	GROUND
O SD3-5	DRIVER SEAT LUMBAR PUMP INFLATE MOTOR	B+	GROUND
O SD3-6	DRIVER SEAT LUMBAR PUMP DEFLATE SOLENOID	B+	GROUND
O SD3-7	DRIVER SEAT FORE / AFT MOTOR SUPPLY	B+	GROUND
O SD3-8	DRIVER SEAT FORE / AFT MOTOR SUPPLY	B+	GROUND
I SD3-9	DRIVER SEAT FORE MOVEMENT REQUEST	B+ (MOMENTARY)	GROUND
I SD3-10	DRIVER SEAT AFT MOVEMENT REQUEST	B+ (MOMENTARY)	GROUND
I SD3-11	DRIVER SEAT CUSHION REAR EDGE LOWER REQUEST	B+ (MOMENTARY)	GROUND
I SD3-12	DRIVER SEAT CUSHION REAR EDGE RAISE REQUEST	B+ (MOMENTARY)	GROUND
I SD3-13	DRIVER SEAT LUMBAR INFLATE REQUEST	B+ (MOMENTARY)	GROUND
I SD3-14	DRIVER SEAT LUMBAR DEFLATE REQUEST	B+ (MOMENTARY)	GROUND
I SD3-15	DRIVER SEAT SQUAB AFT RECLINE REQUEST	R+ (MOMENTARY)	GROUND
I SD3-16	DRIVER SEAT SQUAB FORE RECLINE REQUEST	B+ (MOMENTARY)	GROUND
I SD5-1	DRIVER OR PASSENGER SEAT IDENTIFICATION	GROUND (DRIVER)	
I SD5-2	POWER GROUND	GROUND	GROUND
O SD5-3	DRIVER SEAT RAISE / LOWER MOTOR SUPPLY	B+	GROUND
O SD5-4	DRIVER SEAT RAISE / LOWER MOTOR SUPPLY	B+	GROUND
I SD5-5	BATTERY POWER SUPPLY	B+	B+
I SD5-8	DRIVER SEAT BELT FASTENED	B+ (FASTENED)	GROUND
S SD5-9	SCP NETWORK	2 - 1600 Hz	
S SD5-10	SCP NETWORK	2 - 1600 Hz	

NOTE: REFER TO THE APPENDIX AT THE REAR OF THIS BOOK FOR CAN AND SCP NETWORK MESSAGES.

Fig. 12.2

COMPONENTS

Component	Connector / Type / Color	Location / Access
BODY PROCESSOR MODULE	FC14 / 104-WAY AMP EEEC / GREY	PASSENGER SIDE FASCIA / AIRBAG BRACKET
SEAT BELT SWITCH	SD20 / 2-WAY MULTILOCK 040 / BLACK	BELOW SEAT CUSHION
SEAT CONTROL MODULE - DRIVER	SD3 / 16-WAY FORD 2.8 TIMER / BLACK SD4 / 26-WAY FORD IDC / BLACK SD5 / 10-WAY FORD 2.8 TIMER / BLACK	BELOW SEAT CUSHION
SEAT CUSHION (HEATER) - DRIVER	SD19 / 3-WAY MULTILOCK 070 / YELLOW	SEAT CUSHION
SEAT HEATER SWITCH (CENTER CONSOLE SWITCH PACK)	FC55 / 20-WAY FORD IDC / BLACK	CENTER CONSOLE SWITCH PACK
SEAT LUMBAR PUMP - DRIVER	SD14 / 3-WAY MULTILOCK 070 / YELLOW	SEAT BACK
SEAT MOTORS - DRIVER	SD7 / 6-WAY MULTILOCK 070 / WHITE SD8 / 6-WAY MULTILOCK 070 / WHITE SD9 / 6-WAY MULTILOCK 070 / YELLOW SD17 / 3-WAY MULTILOCK 070 / GREY	BELOW SEAT CUSHION
SQUAB (HEATER) - DRIVER	SD11 / 16-WAY MULTILOCK 040 / BLACK	SEAT SQUAB
SWITCH PACK - DRIVER SEAT		DRIVER SEAT

HARNESS-TO-HARNESS CONNECTORS

Connector	Type / Color	Location / Access
SD1	8-WAY MULTILOCK 070 / YELLOW	BELOW DRIVER SEAT

GROUNDS

Ground	Location / Type
FC3BR	EYELET (PAIR) - RIGHT HAND LEG / TRANSMISSION TUNNEL, LEFT HAND SIDE
FC5L	EYELET (PAIR) - LEFT HAND LEG / RIGHT HAND SEAT
FC5R	EYELET (PAIR) - RIGHT HAND LEG / RIGHT HAND SEAT
FC6L	EYELET (PAIR) - LEFT HAND LEG / LEFT HAND SEAT
FC6R	EYELET (PAIR) - RIGHT HAND LEG / LEFT HAND SEAT

CONTROL MODULE PIN OUT INFORMATION (FOLD OUT PAGE)



The following symbols are used to represent values for Control Module Pin Out data:

I	Input	D	Serial and encoded communications	B+	Battery voltage	KHz	Frequency x 1000
O	Output	C	CAN (Network)	V	Voltage (DC)	MS	Milliseconds
SG	Signal Ground	S	SCP Network	Hz	Frequency	MV	Millivolts

CAUTION: The information on this data page is furnished to aid the user in understanding circuit operation. THIS INFORMATION SHOULD BE USED FOR REFERENCE ONLY.

NOTE: The values listed are approximately those that can be expected at the control module connector pins with all circuit connections made and all components connected and fitted. "Active" means a load is applied or a switch is ON; "Inactive" means a load is not applied or a switch is OFF.

REFER TO THE FRONT OF THE BOOK FOR ILLUSTRATIONS DETAILING THE LOCATION AND IDENTIFICATION OF COMPONENTS, RELAYS, CONNECTORS, HARNESES, GROUNDS, VEHICLE CONTROL MODULES AND CONTROL MODULE PINS.

CONTROL MODULE PIN OUT INFORMATION

BODY PROCESSOR MODULE

Pin	Description	Active	Inactive
I FC14-15	IGNITION SWITCHED GROUND SUPPLY	GROUND	
O FC14-17	LHD RH (RHD LH) SEAT HEATER STATE LED	GROUND (LED ON)	B-
I FC14-32	IGNITION SWITCHED GROUND SUPPLY	GROUND	GROUND
I FC14-35	LHD RH (RHD LH) SEAT HEATER REQUEST	GROUND	B-
O FC14-69	LHD LH SEAT HEATER STATUS LED (RHD = RH)	GROUND	B-
I FC14-80	BATTERY POWER SUPPLY (LOGIC)	B-	B-
S FC14-84	SCP NETWORK	2 - 1600 Hz	
S FC14-85	SCP NETWORK	2 - 1600 Hz	
I FC14-86	LHD LH (RHD RH) SEAT HEATER REQUEST	GROUND (MOMENTARY)	B-

PASSENGER SEAT CONTROL MODULE

Pin	Description	Active	Inactive
O SP3-1	PASSENGER SEAT SQUAB MOTOR SUPPLY - FORWARD	B+	GROUND
O SP3-2	PASSENGER SEAT SQUAB MOTOR SUPPLY - REAR	B+	GROUND
O SP3-3	PASSENGER SEAT HEATER ELEMENTS SUPPLY	B+	GROUND
O SP3-5	PASSENGER SEAT LUMBAR PUMP INFLATE MOTOR	B+	GROUND
O SP3-6	PASSENGER SEAT LUMBAR PUMP DEFLATE SOLENOID	B+	GROUND
O SP3-7	PASSENGER SEAT FORE / AFT MOTOR SUPPLY - FORWARD	B+	GROUND
O SP3-8	PASSENGER SEAT FORE / AFT MOTOR SUPPLY - REAR	B+	GROUND
I SP3-9	PASSENGER SEAT FORE MOVEMENT REQUEST	B+ (MOMENTARY)	GROUND
I SP3-10	PASSENGER SEAT AFT MOVEMENT REQUEST	B+ (MOMENTARY)	GROUND
I SP3-11	PASSENGER SEAT CUSHION REAR EDGE LOWER REQUEST	B+ (MOMENTARY)	GROUND
I SP3-12	PASSENGER SEAT CUSHION REAR EDGE RAISE REQUEST	B+ (MOMENTARY)	GROUND
I SP3-13	PASSENGER SEAT LUMBAR INFLATE REQUEST	B+ (MOMENTARY)	GROUND
I SP3-14	PASSENGER SEAT LUMBAR DEFLATE REQUEST	B+ (MOMENTARY)	GROUND
I SP3-15	PASSENGER SEAT SQUAB AFT RECLINE REQUEST	B+ (MOMENTARY)	GROUND
I SP3-16	PASSENGER SEAT SQUAB FORE RECLINE REQUEST	B+ (MOMENTARY)	GROUND
I SP5-1	DRIVER OR PASSENGER SEAT IDENTIFICATION	GROUND (DRIVER)	GROUND (PASSENGER)
I SP5-2	POWER GROUND	GROUND	GROUND
O SP5-3	PASSENGER SEAT RAISE / LOWER MOTOR SUPPLY	NOT USED	
O SP5-4	PASSENGER SEAT RAISE / LOWER MOTOR SUPPLY	NOT USED	
I SP5-5	BATTERY POWER SUPPLY	NOT USED	B+
SP5-8	NOT USED		
S SP5-9	SCP NETWORK	2 - 1600 Hz	
S SP5-10	SCP NETWORK	2 - 1600 Hz	

NOTE: REFER TO THE APPENDIX AT THE REAR OF THIS BOOK FOR CAN AND SCP NETWORK MESSAGES.

Fig. 12.3

COMPONENTS

Component	Connector / Type / Color	Location / Access
BODY PROCESSOR MODULE	FC14 / 104-WAY AMP EEEEC / GREY	PASSENGER SIDE FASCIA / AIRBAG BRACKET
SEAT BELT SWITCH WIRING (NOT USED)	SP20 / 2-WAY MULTILOCK 040 / BLACK	BELOW SEAT CUSHION
SEAT CONTROL MODULE - PASSENGER	SP3 / 16-WAY FORD 2.8 TIMER / BLACK SP5 / 10-WAY FORD 2.8 TIMER / BLACK	BELOW SEAT CUSHION
SEAT CUSHION (HEATER) - PASSENGER	SP19 / 3-WAY MULTILOCK 070 / YELLOW	SEAT CUSHION
SEAT HEATER SWITCH (CENTER CONSOLE SWITCH PACK)	FC55 / 20-WAY FORD IDC / BLACK	CENTER CONSOLE SWITCH PACK
SEAT LUMBAR PUMP - PASSENGER	SP14 / 3-WAY MULTILOCK 070 / YELLOW	SEAT BACK
SEAT MOTORS - PASSENGER	SP7 / 6-WAY MULTILOCK 070 / WHITE SP8 / 6-WAY MULTILOCK 070 / WHITE SP9 / 6-WAY MULTILOCK 070 / YELLOW	BELOW SEAT CUSHION
SQUAB (HEATER) - PASSENGER	SP17 / 3-WAY MULTILOCK 070 / GREY	SEAT SQUAB
SWITCH PACK - PASSENGER SEAT	SP11 / 16-WAY MULTILOCK 040 / BLACK	PASSENGER SEAT

HARNESS-TO-HARNESS CONNECTORS

Connector	Type / Color	Location / Access
SP1	8-WAY MULTILOCK 070 / YELLOW	BELOW PASSENGER SEAT

GROUNDS

Ground	Location / Type
FC3BR	EYELET (PAIR) - RIGHT HAND LEG / TRANSMISSION TUNNEL, LEFT HAND SIDE
FC5S	EYELET (SINGLE) / RIGHT HAND SEAT
FC6S	EYELET (SINGLE) / LEFT HAND SEAT

CONTROL MODULE PIN OUT INFORMATION (FOLD OUT PAGE)



The following symbols are used to represent values for Control Module Pin Out data:

I	Input	D	Serial and encoded communications	B+	Battery voltage	KHz	Frequency x 1000
O	Output	C	CAN (Network)	V	Voltage (DC)	MS	Milliseconds
SG	Signal Ground	S	SCP Network	Hz	Frequency	MV	Millivolts

CAUTION: The information on this data page is furnished to aid the user in understanding circuit operation. THIS INFORMATION SHOULD BE USED FOR REFERENCE ONLY.

NOTE: The values listed are approximately those that can be expected at the control module connector pins with all circuit connections made and all components connected and fitted. "Active" means a load is applied or a switch is ON; "Inactive" means a load is not applied or a switch is OFF.

REFER TO THE FRONT OF THE BOOK FOR ILLUSTRATIONS DETAILING THE LOCATION AND IDENTIFICATION OF COMPONENTS, RELAYS, CONNECTORS, HARNESSES, GROUNDS, VEHICLE CONTROL MODULES AND CONTROL MODULE PINS.

CONTROL MODULE PIN OUT INFORMATION

BODY PROCESSOR MODULE

Pin	Description	Active	Inactive
I FC14-15	IGNITION SWITCHED GROUND SUPPLY	GROUND	
O FC14-17	LHD RH (RHD LH) SEAT HEATER STATE LED	GROUND (LED ON)	B-
I FC14-32	IGNITION SWITCHED GROUND SUPPLY	GROUND	B-
I FC14-35	LHD RH (RHD LH) SEAT HEATER REQUEST	GROUND	B+
O FC14-69	LHD LH SEAT HEATER STATUS LED (RHD = RH)	GROUND	B-
I FC14-80	BATTERY POWER SUPPLY (LOGIC)	B+	B-
S FC14-84	SCP NETWORK	2 - 1600 Hz	
S FC14-85	SCP NETWORK	2 - 1600 Hz	
I FC14-86	LHD LH (RHD RH) SEAT HEATER REQUEST	GROUND (MOMENTARY)	B-

PASSENGER SEAT CONTROL MODULE

Pin	Description	Active	Inactive
O SP3-1	PASSENGER SEAT SQUAB MOTOR SUPPLY - FORWARD	B+	GROUND
O SP3-2	PASSENGER SEAT SQUAB MOTOR SUPPLY - REAR	B+	GROUND
O SP3-3	PASSENGER SEAT HEATER ELEMENTS SUPPLY	B-	GROUND
O SP3-5	PASSENGER SEAT LUMBAR PUMP INFLATE MOTOR	B+	GROUND
O SP3-6	PASSENGER SEAT LUMBAR PUMP DEFLATE SOLENOID	B+	GROUND
O SP3-7	PASSENGER SEAT FORE / AFT MOTOR SUPPLY - FORWARD	B+	GROUND
O SP3-8	PASSENGER SEAT FORE / AFT MOTOR SUPPLY - REAR	B+	GROUND
I SP3-9	PASSENGER SEAT FORE MOVEMENT REQUEST	B+ (MOMENTARY)	GROUND
I SP3-10	PASSENGER SEAT AFT MOVEMENT REQUEST	B+ (MOMENTARY)	GROUND
I SP3-13	PASSENGER SEAT LUMBAR INFLATE REQUEST	B+ (MOMENTARY)	GROUND
I SP3-14	PASSENGER SEAT LUMBAR DEFLATE REQUEST	B+ (MOMENTARY)	GROUND
I SP3-15	PASSENGER SEAT SQUAB AFT RECLINE REQUEST	B+ (MOMENTARY)	GROUND
I SP3-16	PASSENGER SEAT SQUAB FORE RECLINE REQUEST	B+ (MOMENTARY)	GROUND
I SP5-1	DRIVER OR PASSENGER SEAT IDENTIFICATION	GROUND (DRIVER)	GROUND (PASSENGER)
I SP5-2	POWER GROUND	GROUND	GROUND
I SP5-5	BATTERY POWER SUPPLY	B+	B-
I SP5-8	NOT USED		
S SP5-9	SCP NETWORK	2 - 1600 Hz	
S SP5-10	SCP NETWORK	2 - 1600 Hz	

NOTE: REFER TO THE APPENDIX AT THE REAR OF THIS BOOK FOR CAN AND SCP NETWORK MESSAGES.

Fig. 12.4

COMPONENTS

Component	Connector / Type / Color	Location / Access
BODY PROCESSOR MODULE	FC14 / 104-WAY AMP EEEC / GREY	PASSENGER SIDE FASCIA / AIRBAG BRACKET
SEAT BELT SWITCH WIRING (NOT USED)	SP20 / 2-WAY MULTILOCK 040 / BLACK	BELOW SEAT CUSHION
SEAT CONTROL MODULE - PASSENGER	SP3 / 16-WAY FORD 2.8 TIMER / BLACK SP5 / 10-WAY FORD 2.8 TIMER / BLACK	BELOW SEAT CUSHION
SEAT CUSHION (HEATER) - PASSENGER	SP19 / 3-WAY MULTILOCK 070 / YELLOW	SEAT CUSHION
SEAT HEATER SWITCH (CENTER CONSOLE SWITCH PACK)	FC35 / 20-WAY FORD IDC / BLACK	CENTER CONSOLE SWITCH PACK
SEAT MOTORS - PASSENGER	SP7 / 6-WAY MULTILOCK 070 / WHITE SP8 / 6-WAY MULTILOCK 070 / WHITE SP9 / 6-WAY MULTILOCK 070 / YELLOW	BELOW SEAT CUSHION
SQUAB (HEATER) - PASSENGER	SP17 / 3-WAY MULTILOCK 070 / GREY	SEAT SQUAB
SWITCH PACK - PASSENGER SEAT	SP11 / 16-WAY MULTILOCK 040 / BLACK	PASSENGER SEAT

HARNESS-TO-HARNESS CONNECTORS

Connector	Type / Color	Location / Access
SP1	8-WAY MULTILOCK 070 / YELLOW	BELOW PASSENGER SEAT

GROUNDS

Ground	Location / Type
FC3BR	EYELET (PAIR) - RIGHT HAND LEG / TRANSMISSION TUNNEL, LEFT HAND SIDE
FC6S	EYELET (SINGLE) / RIGHT HAND SEAT
FC6S	EYELET (SINGLE) / LEFT HAND SEAT

CONTROL MODULE PIN OUT INFORMATION (FOLD OUT PAGE)



The following symbols are used to represent values for Control Module Pin Out data:

I Input	D Serial and encoded communications	B+ Battery voltage	KHz Frequency x 1000
O Output	C CAN (Network)	V Voltage (DC)	MS Milliseconds
SG Signal Ground	S SCP Network	Hz Frequency	MV Millivolts

CAUTION: The information on this data page is furnished to aid the user in understanding circuit operation. THIS INFORMATION SHOULD BE USED FOR REFERENCE ONLY.

NOTE: The values listed are approximately those that can be expected at the control module connector pins with all circuit connections made and all components connected and fitted. "Active" means a load is applied or a switch is ON; "Inactive" means a load is not applied or a switch is OFF.

REFER TO THE FRONT OF THE BOOK FOR ILLUSTRATIONS DETAILING THE LOCATION AND IDENTIFICATION OF COMPONENTS, RELAYS, CONNECTORS, HARNESSES, GROUNDS, VEHICLE CONTROL MODULES AND CONTROL MODULE PINS.

CONTROL MODULE PIN OUT INFORMATION

BODY PROCESSOR MODULE

Pin	Description	Active	Inactive
I FC14-5	TRUNK LATCH RELEASE REQUEST	GROUND (MOMENTARY)	B+
I FC14-15	IGNITION SWITCHED GROUND SUPPLY	GROUND	
I FC14-31	FUEL FLAP RELEASE REQUEST	GROUND (MOMENTARY)	B+
I FC14-33	IGNITION SWITCHED GROUND SUPPLY	GROUND	GROUND
I FC14-41	IGNITION GROUND SUPPLY	GROUND	
I FC14-55	VALET SWITCH	GROUND (MOMENTARY)	B+
I FC14-58	NOT-IN-PARK	GROUND (R,N,D,4,3,2)	B+ (PARK)
I FC14-67	KEY IN IGNITION	GROUND (KEY IN)	B+
O FC14-71	DOOR LOCK RELAY ACTIVATE	GROUND (PULSE)	B+
I FC14-80	BATTERY POWER SUPPLY (LOGIC)	B+	B-
S FC14-84	SCP NETWORK	2 - 1600 Hz	
S FC14-85	SCP NETWORK	2 - 1600 Hz	

DRIVER DOOR CONTROL MODULE

Pin	Description	Active	Inactive
I DD10-1	BATTERY POWER SUPPLY	B+	B+
O DD10-5	DOOR LOCK ACTUATOR MOTOR UNLOCK	B+	GROUND
O DD10-6	DOOR LOCK ACTUATOR MOTOR LOCK	B-	GROUND
I DD10-8	LOGIC GROUND	GROUND	GROUND
S DD10-9	SCP NETWORK	2 - 1600 Hz	
S DD10-16	SCP NETWORK	2 - 1600 Hz	
I DD10-17	POWER GROUND	GROUND	GROUND
I DD11-4	DRIVER DOOR LOCK BARREL UNLOCK REQUEST	B+ (MOMENTARY)	GROUND
I DD11-5	EXTERIOR DOOR HANDLE WINDOW DROP REQUEST	B+	
I DD11-12	DRIVER DOOR LOCK BARREL LOCK REQUEST	B+ (MOMENTARY)	GROUND
I DD11-20	DRIVER DOOR SWITCH	GROUND (DOOR OPEN)	B-

PASSENGER DOOR CONTROL MODULE

Pin	Description	Active	Inactive
I DP10-1	BATTERY POWER SUPPLY	B+	B+
O DP10-5	PASSENGER DOOR LOCK ACTUATOR MOTOR UNLOCK	B+	GROUND
O DP10-6	PASSENGER DOOR LOCK ACTUATOR MOTOR LOCK	B+	GROUND
I DP10-8	LOGIC GROUND	GROUND	GROUND
S DP10-9	SCP NETWORK	2 - 1600 Hz	
S DP10-16	SCP NETWORK	2 - 1600 Hz	
I DP10-17	POWER GROUND	GROUND	GROUND
I DP11-5	EXTERIOR DOOR HANDLE WINDOW DROP REQUEST	B+	GROUND
I DP11-20	PASSENGER DOOR SWITCH	GROUND (DOOR OPEN)	B-

SECURITY AND LOCKING CONTROL MODULE

Pin	Description	Active	Inactive
O BT40-1	TRUNK RELEASE SOLENOID	B+	GROUND
O BT40-2	FUEL FILLER FLAP SOLENOID	B+	GROUND
S BT40-8	SCP NETWORK	2 - 1600 Hz	
I BT40-13	GROUND	GROUND	GROUND
I BT40-14	GROUND	GROUND	GROUND
I BT40-15	BATTERY POWER SUPPLY	B+	B+
S BT40-16	SCP NETWORK	2 - 1600 Hz	
I BT41-5	TRUNK SWITCH	GROUND	B+
I BT41-7	PASSENGER DOOR LOCK ACTUATOR LOCK STATUS	GROUND (LOCKED)	B+
I BT41-19	DRIVER DOOR LOCK ACTUATOR LOCK STATUS	GROUND (LOCKED)	B+
I RH20-1	KEY FOB ANTENNA		
I RH20-2	KEY FOB ANTENNA SHIELD	GROUND	GROUND

NOTE: REFER TO THE APPENDIX AT THE REAR OF THIS BOOK FOR CAN AND SCP NETWORK MESSAGES.

The following symbols are used to represent values for Control Module Pin Out data:

I	Input	D	Serial and encoded communications	B+	Battery voltage	KHz	Frequency x 1000
O	Output	C	CAN (Network)	V	Voltage (DC)	MS	Milliseconds
SG	Signal Ground	S	SCP Network	Hz	Frequency	MV	Millivolts

CAUTION: The information on this data page is furnished to aid the user in understanding circuit operation. THIS INFORMATION SHOULD BE USED FOR REFERENCE ONLY.

NOTE: The values listed are approximately those that can be expected at the control module connector pins with all circuit connections made and all components connected and fitted. "Active" means a load is applied or a switch is ON; "Inactive" means a load is not applied or a switch is OFF.

Fig. 13.1

COMPONENTS

Component	Connector / Type / Color	Location / Access
BODY PROCESSOR MODULE	FC14 / 104-WAY AMP FFEC / GREY	PASSENGER SIDE FASCIA / AIRBAG BRACKET
DOOR CONTROL MODULE - DRIVER	DD10 / 22-WAY FORD 2.8 TIMER / BLUE DD11 / 22-WAY FORD 2.8 TIMER / BLACK	DRIVER DOOR / DOOR CASING
DOOR CONTROL MODULE - PASSENGER	DP10 / 22-WAY FORD 2.8 TIMER / BLUE DP11 / 22-WAY FORD 2.8 TIMER / BLACK	PASSENGER DOOR / DOOR CASING
DOOR LOCK ACTUATOR - DRIVER	DD3 / 13-WAY ECONOSEAL III LC / BLACK	DRIVER DOOR / DOOR CASING
DOOR LOCK ACTUATOR - PASSENGER	DP3 / 13-WAY ECONOSEAL III LC / BLACK	PASSENGER DOOR / DOOR CASING
DOOR LOCK SWITCH - PASSENGER	DP3 / 13-WAY ECONOSEAL III LC / BLACK	PASSENGER DOOR / DOOR CASING
DOOR LOCK SWITCHES - DRIVER	DD3 / 13-WAY ECONOSEAL III LC / BLACK	DRIVER DOOR / DOOR CASING
DOOR SWITCH - DRIVER	DD3 / 13-WAY ECONOSEAL III LC / BLACK	DRIVER DOOR / DOOR CASING
DOOR SWITCH - PASSENGER	DP3 / 13-WAY ECONOSEAL III LC / BLACK	PASSENGER DOOR / DOOR CASING
FUEL FILL FLAP SOLENOID	IC24 / 2-WAY LABINAL / NATURAL	TRUNK / FUEL FILL
IGNITION SWITCH (KEY-IN SWITCH)	FC4 / 8-WAY MULTILOCK 070 / WHITE	STEERING COLUMN
KEY FOB ANTENNA (CONVERTIBLE)	HARD WIRED	TOP OF BACKLIGHT
KEY FOB ANTENNA (COUPE)	RH7 / COAXIAL CONNECTOR	TOP OF BACKLIGHT
NOT-IN-PARK MICROSWITCH	FC87 / 3-WAY MULTILOCK 070 / WHITE	GEAR SELECTOR ASSEMBLY
SECURITY AND LOCKING CONTROL MODULE	BT40 / 16-WAY FORD 2.8 TIMER / BLACK BT41 / 26-WAY FORD IDC / BLACK RH20 / COAXIAL CONNECTOR	TRUNK / ELECTRICAL CARRIER
TRUNK AND FUEL FILL RELEASE SWITCH	FC41 / 10-WAY AMP MQL / NATURAL	FASCIA / DRIVER SIDE
TRUNK RELEASE SOLENOID	BT43 / 2-WAY LABINAL / BROWN	TRUNK / LEFT HAND SIDE
TRUNK SWITCH	BT46 / 2-WAY AUGAT 1.6 / BLACK	TRUNK
VALET SWITCH	FC67 / 10-WAY AMP MQL / BLACK	DRIVER KNEE BOLSTER

RELAYS

Relay	Color / Stripe	Connector / Color	Location / Access
DOOR LOCKING RELAY	BLACK / VIOLET	FC24 / VIOLET	RH FASCIA RELAYS

HARNESS-TO-HARNESS CONNECTORS

Connector	Type / Color	Location / Access
AC13	20-WAY MULTILOCK 070 / YELLOW	FASCIA BOTTOM CONNECTOR MOUNTING BRACKET / RIGHT HAND SIDE
AC14	14-WAY MULTILOCK 070 / GREY	FASCIA BOTTOM CONNECTOR MOUNTING BRACKET / RIGHT HAND SIDE
AC15	20-WAY MULTILOCK 070 / GREY	FASCIA BOTTOM CONNECTOR MOUNTING BRACKET / RIGHT HAND SIDE
BT1	20-WAY MULTILOCK 070 / WHITE	TRUNK / ABOVE RIGHT HAND REAR WHEEL ARCH
BT2	20-WAY MULTILOCK 070 / WHITE	TRUNK / ABOVE RIGHT HAND REAR WHEEL ARCH
DD1	23-WAY AMP - FORD / BLACK	DRIVER SIDE 'A' POST MOUNTING BRACKET / 'A' POST TRIM
DP1	23-WAY AMP - FORD / BLACK	PASSENGER SIDE 'A' POST / 'A' POST TRIM
IC4	4-WAY MULTILOCK 070 / WHITE	TRUNK / LEFT OF ANTENNA ASSEMBLY
RH2	20-WAY MULTILOCK 070 / WHITE	REAR OF CENTER CONSOLE ASSEMBLY

GROUNDS

Ground	Location / Type
BT1AL	EYELET (PAIR) - LEFT HAND LEG / ADJACENT TO BATTERY
BT1AR	EYELET (PAIR) - RIGHT HAND LEG / ADJACENT TO BATTERY
FC2AR	EYELET (PAIR) - RIGHT HAND LEG / RIGHT HAND 'A' POST
FC2BL	EYELET (PAIR) - LEFT HAND LEG / RIGHT HAND 'A' POST
FC2BR	EYELET (PAIR) - RIGHT HAND LEG / RIGHT HAND 'A' POST
FC3BL	EYELET (PAIR) - LEFT HAND LEG / TRANSMISSION TUNNEL, LEFT HAND SIDE
FC3BR	EYELET (PAIR) - RIGHT HAND LEG / TRANSMISSION TUNNEL, LEFT HAND SIDE
FC4AR	EYELET (PAIR) - RIGHT HAND LEG / LEFT HAND 'A' POST
FC4BL	EYELET (PAIR) - LEFT HAND LEG / LEFT HAND 'A' POST
FC4BR	EYELET (PAIR) - RIGHT HAND LEG / LEFT HAND 'A' POST
RH3S	EYELET (SINGLE) / ROOF, ADJACENT TO BACKLIGHT

CONTROL MODULE PIN OUT INFORMATION (FOLD OUT PAGE)



CONTROL MODULE PIN OUT INFORMATION

BODY PROCESSOR MODULE

Pin	Description	Active	Inactive
I FC14-6	WASHER FLUID LEVEL LOW	0 V	B+
I FC14-9	INTERMITTENT WIPER REQUEST	GROUND (MOMENTARY)	B+
I FC14-15	IGNITION SWITCHED GROUND SUPPLY	GROUND	
I FC14-16	SIDE LAMP REQUEST	GROUND	B+
O FC14-18	POWERWASH RELAY ACTIVATE	GROUND	B+
O FC14-19	WIPER FAST / SLOW RELAY ACTIVATE	GROUND	B+
O FC14-26	WINDSHIELD WASH PUMP AND FLUID LEVEL SENSOR SUPPLY	GROUND	B+
I FC14-34	FAST WIPE REQUEST	B+	GROUND
I FC14-37	WASH REQUEST	GROUND	B+
O FC14-43	WIPER RUN / STOP RELAY ACTIVATE	0 V (MOMENTARY)	B+
I FC14-60	WIPER MOTOR PARK SWITCH	GROUND	B+ (NOT PARKED)
I FC14-80	BATTERY POWER SUPPLY (LOGIC)	GROUND (PARKED)	B+
I FC14-94	SLOW WIPE REQUEST	B+	B+
I FC14-104	LIGHTING / MOTORS BATTERY POWER SUPPLY	GROUND (WIPERS ON)	B+

Fig. 14.1

COMPONENTS

Component	Connector / Type / Color	Location / Access
BODY PROCESSOR MODULE	FC14 / 104-WAY AMP EEEC / GREY	PASSENGER SIDE FASCIA / AIRBAG BRACKET
FUSE BOX - ENGINE COMPARTMENT	LF5 / 10-WAY U.T.A. FUSEBOX / NATURAL LF6 / 10-WAY U.T.A. FUSEBOX / BLACK LF7 / 10-WAY U.T.A. FUSEBOX / GREEN LF8 / 10-WAY U.T.A. FUSEBOX / BLUE LF70 / EYELET	ENGINE COMPARTMENT / LEFT FRONT
LIGHTING STALK (COLUMN SWITCHGEAR)	SC2 / 10-WAY MULTILOCK 070 / YELLOW	STEERING COLUMN
POWERWASH PUMP	LF25 / 2-WAY ECONOSEAL III HC / BLACK	LEFT FRONT FENDER / WHEEL ARCH LINER
WASH / WIPE STALK (COLUMN SWITCHGEAR)	SC1 / 12-WAY MULTILOCK 070 / WHITE	STEERING COLUMN
WINDSHIELD WASH PUMP AND FLUID LEVEL SENSOR	LF27 / 3-WAY AUGAT 1.6 / BLACK	LEFT FRONT FENDER / WHEEL ARCH LINER
WIPER MOTOR	EM51 / 5-WAY FORD FAO / BLACK	BASE OF WINDSHIELD / AIR INTAKE PLENUM

RELAYS

Relay	Color / Stripe	Connector / Color	Location / Access
WIPER RUN / STOP RELAY	BLACK	LF48 / BLACK	LH ENCLOSURE RELAYS
WIPER FAST / SLOW RELAY	BLACK	LF49 / BLACK	LH ENCLOSURE RELAYS
POWERWASH RELAY (#4)	BROWN	BUS	ENGINE COMPARTMENT FUSE BOX

HARNESSTO-HARNESSTO CONNECTORS

Connector	Type / Color	Location / Access
LF3	13-WAY ECONOSEAL III LC / WHITE	ENGINE COMPARTMENT / LEFT HAND ENCLOSURE
LF1	20-WAY MULTILOCK 070 / GREY	LEFT HAND 'A' POST CONNECTOR MOUNTING BRACKET / 'A' POST TRIM
LF60	20-WAY MULTILOCK 070 / WHITE	LEFT HAND 'A' POST CONNECTOR MOUNTING BRACKET / 'A' POST TRIM

GROUNDSTO

Ground	Location / Type
FC3BL	EYELET (PAIR) - LEFT HAND LEG / TRANSMISSION TUNNEL, LEFT HAND SIDE
LF1AR	EYELET (PAIR) - RIGHT HAND LEG / RIGHT HAND HEADLAMP
LF3BS	EYELET (SINGLE) / ENGINE COMPARTMENT, FORWARD OF LEFT HAND HOOD CATCH
LF3BS	EYELET (SINGLE) / ENGINE COMPARTMENT, FORWARD OF LEFT HAND HOOD CATCH

CONTROL MODULE PIN OUT INFORMATION (FOLD OUT PAGE)



The following symbols are used to represent values for Control Module Pin Out data:

I	Input	D	Serial and encoded communications	B+	Battery voltage	KHz	Frequency x 1000
O	Output	C	CAN (Network)	V	Voltage (DC)	MS	Milliseconds
SG	Signal Ground	S	SCP Network	Hz	Frequency	MV	Millivolts

CAUTION: The information on this data page is furnished to aid the user in understanding circuit operation. THIS INFORMATION SHOULD BE USED FOR REFERENCE ONLY.

NOTE: The values listed are approximately those that can be expected at the control module connector pins with all circuit connections made and all components connected and fitted. "Active" means a load is applied or a switch is ON; "Inactive" means a load is not applied or a switch is OFF.

REFER TO THE FRONT OF THE BOOK FOR ILLUSTRATIONS DETAILING THE LOCATION AND IDENTIFICATION OF COMPONENTS, RELAYS, CONNECTORS, HARNESSES, GROUNDSTO, VEHICLE CONTROL MODULES AND CONTROL MODULE PINS.

CONTROL MODULE PIN OUT INFORMATION

BODY PROCESSOR MODULE

Pin	Description	Active	Inactive
S FC14-84	SCP NETWORK	2 - 1600 Hz	
S FC14-85	SCP NETWORK	2 - 1600 Hz	

DRIVER DOOR CONTROL MODULE

Pin	Description	Active	Inactive
I DD10-1	BATTERY POWER SUPPLY	B+	B+
O DD10-7	WINDOW LIFT MOTOR DOWN SUPPLY	B+	GROUND
I DD10-8	LOGIC GROUND	GROUND	GROUND
S DD10-9	SCP NETWORK	2 - 1600 Hz	
I DD10-10	DRIVER SWITCH PACK LH WINDOW DOWN REQUEST	GROUND (MOMENTARY)	B-
I DD10-11	DRIVER WINDOW LIFT SENSOR FEEDBACK	2 V = UP; 12 V = DOWN	
J DD10-12	DRIVER WINDOW LIFT SENSOR FEEDBACK	2 V = UP; 12 V = DOWN	
O DD10-13	DRIVER WINDOW LIFT SENSOR REFERENCE VOLTAGE	B+	B+
O DD10-15	DRIVER WINDOW LIFT MOTOR UP SUPPLY	B+	GROUND
S DD10-16	SCP NETWORK	2 - 1600 Hz	
I DD10-17	POWER GROUND	GROUND	GROUND
I DD10-18	DRIVER SWITCH PACK LH WINDOW UP REQUEST	GROUND (MOMENTARY)	GROUND
I DD10-19	DRIVER SWITCH PACK RH WINDOW UP REQUEST	GROUND (MOMENTARY)	GROUND
I DD11-4	DRIVER DOOR LOCK BARREL UNLOCK REQUEST	B+ (MOMENTARY)	GROUND
I DD11-7	DRIVER SWITCH PACK RH WINDOW DOWN REQUEST	B+ (MOMENTARY)	GROUND
I DD11-12	DRIVER DOOR LOCK BARREL LOCK REQUEST	B+ (MOMENTARY)	GROUND

MAJOR INSTRUMENT PACK

Pin	Description	Active	Inactive
S FC25-19	SCP NETWORK	2 - 1600 Hz	
S FC25-20	SCP NETWORK	2 - 1600 Hz	

PASSENGER DOOR CONTROL MODULE

Pin	Description	Active	Inactive
I DP10-1	BATTERY POWER SUPPLY	B+	B+
O DP10-7	PASSENGER WINDOW LIFT MOTOR DOWN SUPPLY	B+	GROUND
I DP10-8	LOGIC GROUND	GROUND	GROUND
S DP10-9	SCP NETWORK	2 - 1600 Hz	
I DP10-10	PASSENGER SWITCH PACK RH WINDOW DOWN REQUEST	B+ (MOMENTARY)	GROUND
I DP10-11	PASSENGER WINDOW LIFT MOVEMENT SENSOR FEEDBACK	2 V = UP; 12 V = DOWN	
I DP10-12	PASSENGER WINDOW LIFT MOVEMENT SENSOR FEEDBACK	2 V = UP; 12 V = DOWN	
O DP10-13	PASSENGER WINDOW LIFT MOVEMENT SENSOR REFERENCE VOLTAGE	B+	B+
O DP10-15	PASSENGER WINDOW LIFT MOTOR UP SUPPLY	B+	GROUND
S DP10-16	SCP NETWORK	2 - 1600 Hz	
I DP10-17	POWER GROUND	GROUND	GROUND
I DP10-18	PASSENGER SWITCH PACK RH WINDOW UP REQUEST	B+ (MOMENTARY)	GROUND

SECURITY AND LOCKING CONTROL MODULE

Pin	Description	Active	Inactive
S BT40-8	SCP NETWORK	2 - 1600 Hz	
S BT40-16	SCP NETWORK	2 - 1600 Hz	

NOTE: REFER TO THE APPENDIX AT THE REAR OF THIS BOOK FOR CAN AND SCP NETWORK MESSAGES.

Fig. 15.1

COMPONENTS

Component	Connector / Type / Color	Location / Access
BODY PROCESSOR MODULE	FC14 / 104-WAY AMP EEEC / GREY	PASSENGER SIDE FASCIA / AIRBAG BRACKET
DOOR CONTROL MODULE - DRIVER	DD10 / 22-WAY FORD 2.8 TIMER / BLUE DD11 / 22-WAY FORD 2.8 TIMER / BLACK	DRIVER DOOR / DOOR CASING
DOOR CONTROL MODULE - PASSENGER	DP10 / 22-WAY FORD 2.8 TIMER / BLUE DP11 / 22-WAY FORD 2.8 TIMER / BLACK	PASSENGER DOOR / DOOR CASING
DOOR LOCK SWITCHES - DRIVER	DD3 / 13-WAY ECONOSEAL III LC / BLACK	DRIVER DOOR / DOOR CASING
MAJOR INSTRUMENT PACK	FC25 / 48-WAY AMP PCB SIGNAL / BLACK FC26 / 24-WAY AMP PCB SIGNAL / BLACK	FASCIA
SECURITY AND LOCKING CONTROL MODULE	BT40 / 16-WAY FORD 2.8 TIMER / BLACK BT41 / 26-WAY FORD IDC / BLACK RH20 / COAXIAL CONNECTOR	TRUNK / ELECTRICAL CARRIER
WINDOW LIFT SWITCHES - DRIVER DOOR	DD17 / 20-WAY MULTILOCK 040 / BLACK	DRIVER DOOR SWITCH PACK
WINDOW LIFT SWITCHES - PASSENGER DOOR (PASSENGER DOOR SWITCH PACK)	DP17 / 20-WAY MULTILOCK 040 / BLACK	PASSENGER DOOR SWITCH PACK
WINDOW LIFT - DRIVER	DD16 / 6-WAY ECONOSEAL III LC / BLACK	DRIVER DOOR
WINDOW LIFT - PASSENGER	DP16 / 6-WAY ECONOSEAL III LC / BLACK	DRIVER DOOR

HARNESS-TO-HARNESS CONNECTORS

Connector	Type / Color	Location / Access
AC14	14-WAY MULTILOCK 070 / GREY	FASCIA BOTTOM CONNECTOR MOUNTING BRACKET / RIGHT HAND SIDE
AC15	20-WAY MULTILOCK 070 / GREY	FASCIA BOTTOM CONNECTOR MOUNTING BRACKET / RIGHT HAND SIDE
AC16	6-WAY MULTILOCK 070 / YELLOW	LEFT HAND 'A' POST CONNECTOR MOUNTING BRACKET / 'A' POST TRIM
BT1	20-WAY MULTILOCK 070 / WHITE	TRUNK / ABOVE RIGHT HAND REAR WHEEL ARCH
BT2	20-WAY MULTILOCK 070 / WHITE	TRUNK / ABOVE RIGHT HAND REAR WHEEL ARCH
DD1	23-WAY AMP - FORD / BLACK	DRIVER SIDE 'A' POST MOUNTING BRACKET / 'A' POST TRIM
DP1	23-WAY AMP - FORD / BLACK	PASSENGER SIDE 'A' POST / 'A' POST TRIM
FC62	10-WAY AMP MQL / BLACK	CONVERTIBLE TOP SWITCH
RF1	18-WAY MULTILOCK 070 / YELLOW	RIGHT HAND 'A' POST CONNECTOR MOUNTING BRACKET / 'A' POST TRIM
RH12	18-WAY MULTILOCK 070 / YELLOW	REAR OF CENTER CONSOLE ASSEMBLY
RH2	20-WAY MULTILOCK 070 / WHITE	REAR OF CENTER CONSOLE ASSEMBLY

GROUNDS

Ground	Location / Type
FC2AR	EYELET (PAIR) - RIGHT HAND LEG / RIGHT HAND 'A' POST
FC4AR	EYELET (PAIR) - RIGHT HAND LEG / LEFT HAND 'A' POST

CONTROL MODULE PIN OUT INFORMATION (FOLD OUT PAGE)



The following symbols are used to represent values for Control Module Pin Out data:

I	Input	D	Serial and encoded communications	B+	Battery voltage	KHz	Frequency x 1000
O	Output	C	CAN (Network)	V	Voltage (DC)	MS	Milliseconds
SG	Signal Ground	S	SCP Network	Hz	Frequency	MV	Millivolts

CAUTION: The information on this data page is furnished to aid the user in understanding circuit operation. THIS INFORMATION SHOULD BE USED FOR REFERENCE ONLY.

NOTE: The values listed are approximately those that can be expected at the control module connector pins with all circuit connections made and all components connected and fitted. "Active" means a load is applied or a switch is ON; "Inactive" means a load is not applied or a switch is OFF.

REFER TO THE FRONT OF THE BOOK FOR ILLUSTRATIONS DETAILING THE LOCATION AND IDENTIFICATION OF COMPONENTS, RELAYS, CONNECTORS, HARNESSSES, GROUNDS, VEHICLE CONTROL MODULES AND CONTROL MODULE PINS.

CONTROL MODULE PIN OUT INFORMATION

BODY PROCESSOR MODULE

Pin	Description	Active	Inactive
I FC14-10	CONVERTIBLE TOP RAISE REQUEST	GROUND (MOMENTARY)	B+
I FC14-15	IGNITION SWITCHED GROUND SUPPLY	GROUND	B+
I FC14-32	IGNITION SWITCHED GROUND SUPPLY	GROUND	GROUND
I FC14-33	IGNITION SWITCHED GROUND SUPPLY	GROUND	GROUND
I FC14-36	CONVERTIBLE TOP READY TO LATCH	GROUND	B+
I FC14-62	CONVERTIBLE TOP LATCH CLOSED	GROUND (CLOSED)	B+
I FC14-63	CONVERTIBLE TOP LOWER REQUEST	GROUND (MOMENTARY)	B+
O FC14-77	REAR QUARTER GLASS DOWN RELAYS ACTIVATE	GROUND	B+
I FC14-80	BATTERY POWER SUPPLY (LOGIC)	B+	B+
S FC14-84	SCP NETWORK	2 - 1600 Hz	B+
S FC14-85	SCP NETWORK	2 - 1600 Hz	B+
I FC14-89	CONVERTIBLE TOP CLOSED	GROUND	B+
O FC14-98	REAR QUARTER GLASS UP RELAYS ACTIVATE	GROUND	B+

DRIVER DOOR CONTROL MODULE

Pin	Description	Active	Inactive
S DD10-9	SCP NETWORK	2 - 1600 Hz	B+
S DD10-16	SCP NETWORK	2 - 1600 Hz	B+

MAJOR INSTRUMENT PACK

Pin	Description	Active	Inactive
S FC25-19	SCP NETWORK	2 - 1600 Hz	B+
S FC25-20	SCP NETWORK	2 - 1600 Hz	B+

PASSENGER DOOR CONTROL MODULE

Pin	Description	Active	Inactive
S DP10-9	SCP NETWORK	2 - 1600 Hz	B+
S DP10-16	SCP NETWORK	2 - 1600 Hz	B+
C FC25-24	CAN NETWORK	15 - 1500 Hz	B+
C FC25-47	CAN NETWORK	15 - 1500 Hz	B+

SECURITY AND LOCKING CONTROL MODULE

Pin	Description	Active	Inactive
O BT40-3	TOP UP RELAY ACTIVATE	B+	GROUND
O BT40-4	LATCH CONTROL VALVE	B+	GROUND
I BT40-6	BATTERY POWER SUPPLY	B+	B+
S BT40-8	SCP NETWORK	2 - 1600 Hz	B+
O BT40-9	MAIN CONTROL VALVE	B+	GROUND
O BT40-10	TOP DOWN RELAY ACTIVATE	B+	GROUND
I BT40-13	GROUND	GROUND	GROUND
I BT40-14	GROUND	GROUND	GROUND
S BT40-16	SCP NETWORK	2 - 1600 Hz	GROUND
I BT41-3	CONVERTIBLE TOP DOWN SWITCH	GROUND	B+

NOTE: REFER TO THE APPENDIX AT THE REAR OF THIS BOOK FOR CAN AND SCP NETWORK MESSAGES.

Fig. 15.2

COMPONENTS

Component	Connector / Type / Color	Location / Access
BODY PROCESSOR MODULE	FC14 / 104-WAY AMP EEEC / GREY	PASSENGER SIDE FASCIA / AIRBAG BRACKET
CONVERTIBLE TOP CLOSED SWITCH	RF4 / 6-WAY MULTILOCK 070 / WHITE	TOP OF WINDSHIELD
CONVERTIBLE TOP DOWN SWITCH	RH29 / 3-WAY MULTILOCK 070 / WHITE	RIGHT HAND OPERATING CYLINDER
CONVERTIBLE TOP LATCH CLOSED SWITCH	RF4 / 6-WAY MULTILOCK 070 / WHITE	TOP OF WINDSHIELD
CONVERTIBLE TOP PUMP	BT15 / 2-WAY AMP / NATURAL	TRUNK / RIGHT HAND SIDE
CONVERTIBLE TOP RAISED SWITCH	RH29 / 3-WAY MULTILOCK 070 / WHITE	RIGHT HAND OPERATING CYLINDER
CONVERTIBLE TOP READY-TO-LATCH SWITCH	RF4 / 6-WAY MULTILOCK 070 / WHITE	TOP OF WINDSHIELD
CONVERTIBLE TOP SWITCH	FC62 / 10-WAY AMP MOL / BLACK	FORWARD OF GEAR SELECTOR
DOOR CONTROL MODULE - DRIVER	DD10 / 22-WAY FORD 2.8 TIMER / BLUE DD11 / 22-WAY FORD 2.8 TIMER / BLACK	DRIVER DOOR / DOOR CASING
DOOR CONTROL MODULE - PASSENGER	DP10 / 22-WAY FORD 2.8 TIMER / BLUE DP11 / 22-WAY FORD 2.8 TIMER / BLACK	PASSENGER DOOR / DOOR CASING
LATCH CONTROL VALVE	BT53 / 2-WAY D & R / BLUE	TRUNK / CONVERTIBLE TOP PUMP
MAIN CONTROL VALVE	BT54 / 2-WAY D & R / ORANGE	TRUNK / CONVERTIBLE TOP PUMP
MAJOR INSTRUMENT PACK	FC25 / 48-WAY AMP PCB SIGNAL / BLACK FC26 / 24-WAY AMP PCB SIGNAL / BLACK	FASCIA
QUARTER LIGHT LIFT - LH	RH33 / 2-WAY ECONOSEAL III HC / BLACK	REAR QUARTER PANEL
QUARTER LIGHT LIFT - RH	RH34 / 2-WAY ECONOSEAL III HC / BLACK	REAR QUARTER PANEL
SECURITY AND LOCKING CONTROL MODULE	BT40 / 16-WAY FORD 2.8 TIMER / BLACK BT41 / 26-WAY FORD IDC / BLACK RH20 / COAXIAL CONNECTOR	TRUNK / ELECTRICAL CARRIER

RELAYS

Relay	Color / Stripe	Connector / Color	Location / Access
QUARTER DOWN RELAY - LH	BLACK (VIOLET)	BT74 / VIOLET	TRUNK RELAYS
QUARTER DOWN RELAY - RH	BLACK (VIOLET)	BT76 / VIOLET	TRUNK RELAYS
QUARTER UP RELAY - LH	BLACK (VIOLET)	BT74 / VIOLET	TRUNK RELAYS
QUARTER UP RELAY - RH	BLACK (VIOLET)	BT76 / VIOLET	TRUNK RELAYS
TOP UP RELAY	BLACK	BT16 / BLACK	TRUNK RELAYS
TOP DOWN RELAY	BLACK	BT17 / BLACK	TRUNK RELAYS

HARNESSTO-HARNESSTO CONNECTORS

Connector	Type / Color	Location / Access
AC14	14-WAY MULTILOCK 070 / GREY	FASCIA BOTTOM CONNECTOR MOUNTING BRACKET / RIGHT HAND SIDE
BT1	20-WAY MULTILOCK 070 / WHITE	TRUNK / ABOVE RIGHT HAND REAR WHEEL ARCH
BT3	18-WAY MULTILOCK 070 / YELLOW	TRUNK / ABOVE RIGHT HAND REAR WHEEL ARCH
DD1	23-WAY AMP - FORD / BLACK	DRIVER SIDE 'A' POST MOUNTING BRACKET / 'A' POST TRIM
DP1	23-WAY AMP - FORD / BLACK	PASSENGER SIDE 'A' POST / 'A' POST TRIM
RF1	18-WAY MULTILOCK 070 / YELLOW	RIGHT HAND 'A' POST CONNECTOR MOUNTING BRACKET / 'A' POST TRIM
RH2	20-WAY MULTILOCK 070 / WHITE	REAR OF CENTER CONSOLE ASSEMBLY
RH5	3-WAY MULTILOCK 070 / WHITE	BEHIND LEFT HAND QUARTER TRIM PANEL
RH6	3-WAY MULTILOCK 070 / WHITE	BEHIND RIGHT HAND QUARTER TRIM PANEL
RH12	18-WAY MULTILOCK 070 / YELLOW	REAR OF CENTER CONSOLE ASSEMBLY

GROUNDS

Ground	Location / Type
BT1AL	EYELET (PAIR) - LEFT HAND LEG / ADJACENT TO BATTERY
BT1AR	EYELET (PAIR) - RIGHT HAND LEG / ADJACENT TO BATTERY
BT1BL	EYELET (PAIR) - LEFT HAND LEG / ADJACENT TO BATTERY
BT1BR	EYELET (PAIR) - RIGHT HAND LEG / ADJACENT TO BATTERY
BT2BL	EYELET (PAIR) - LEFT HAND LEG / TRUNK, RIGHT REAR
FC3BR	EYELET (PAIR) - RIGHT HAND LEG / TRANSMISSION TUNNEL, LEFT HAND SIDE
RH1S	EYELET (SINGLE) / RIGHT HAND REAR QUARTER

CONTROL MODULE PIN OUT INFORMATION (FOLD OUT PAGE)



The following symbols are used to represent values for Control Module Pin Out data:

I	Input	D	Serial and encoded communications	B+	Battery voltage	KHz	Frequency x 1000
O	Output	C	CAN (Network)	V	Voltage (DC)	MS	Milliseconds
SG	Signal Ground	S	SCP Network	Hz	Frequency	MV	Millivolts

CAUTION: The information on this data page is furnished to aid the user in understanding circuit operation. THIS INFORMATION SHOULD BE USED FOR REFERENCE ONLY.

NOTE: The values listed are approximately those that can be expected at the control module connector pins with all circuit connections made and all components connected and fitted. "Active" means a load is applied or a switch is ON; "Inactive" means a load is not applied or a switch is OFF.

REFER TO THE FRONT OF THE BOOK FOR ILLUSTRATIONS DETAILING THE LOCATION AND IDENTIFICATION OF COMPONENTS, RELAYS, CONNECTORS, HARNESSES, GROUNDS, VEHICLE CONTROL MODULES AND CONTROL MODULE PINS.

CONTROL MODULE PIN OUT INFORMATION

MAJOR INSTRUMENT PACK

Pin	Description	Active	Inactive
C	FC25-24	CAN NETWORK	15 - 1500 Hz
C	FC25-47	CAN NETWORK	15 - 1500 Hz
O	FC26-20	VEHICLE SPEED	22 Hz @ 10 MPH (16 KM/H); 44 Hz @ 20 MPH (32 KM/H) @ B+

NOTE: REFER TO THE APPENDIX AT THE REAR OF THIS BOOK FOR CAN AND SCP NETWORK MESSAGES.

Fig. 16.1

COMPONENTS

Component	Connector / Type / Color	Location / Access
ANTENNA MOTOR	BT19 / 6-WAY YAZAKI C.S.U. / WHITE	TRUNK / RIGHT HAND SIDE
CD AUTO-CHANGER	IC7 / CD DATA CONNECTOR	TRUNK / RIGHT HAND SIDE
FULL RANGE SPEAKER - DRIVER DOOR	DD19 / 2-WAY GROTE AND HARTMAN MDK / BLACK	DRIVER DOOR CASING
FULL RANGE SPEAKER - PASSENGER DOOR	DP19 / 2-WAY GROTE AND HARTMAN MDK / BLACK	PASSENGER DOOR CASING
MAJOR INSTRUMENT PACK	FC25 / 48-WAY AMP PCB SIGNAL / BLACK FC26 / 24-WAY AMP PCB SIGNAL / BLACK	FASCIA
RADIO / CASSETTE HEAD UNIT	IC8 / COAXIAL CONNECTOR IC10 / 20-WAY MULTILOCK 070 / WHITE IC13 / COAXIAL CONNECTOR IC14 / POWER AMPLIFIER CONNECTOR	CENTER CONSOLE
RADIO ANTENNA	IC12 / COAXIAL CONNECTOR	TRUNK / RIGHT HAND SIDE
RADIO CONTROL SWITCHES (STEERING WHEEL)	SW4 / 3-WAY EPC / BLACK AND WHITE	STEERING WHEEL
RADIO TELEPHONE CONNECTOR	RT20 / 10-WAY MULTILOCK 070 / YELLOW	REAR OF CENTER CONSOLE ASSEMBLY
REAR QUARTER FULL RANGE SPEAKER - DRIVER SIDE	RH27 / 2-WAY GROTE AND HARTMAN MDK / BLACK	INTERIOR REAR QUARTER PANEL
REAR QUARTER FULL RANGE SPEAKER - PASSENGER SIDE	RH26 / 2-WAY GROTE AND HARTMAN MDK / BLACK	INTERIOR REAR QUARTER PANEL

HARNESS-TO-HARNESS CONNECTORS

Connector	Type / Color	Location / Access
AC14	14-WAY MULTILOCK 070 / GREY	FASCIA BOTTOM CONNECTOR MOUNTING BRACKET / RIGHT HAND SIDE
BT1	20-WAY MULTILOCK 070 / WHITE	TRUNK / ABOVE RIGHT HAND REAR WHEEL ARCH
DD1	23-WAY AMP - FORD / BLACK	DRIVER SIDE 'A' POST MOUNTING BRACKET / 'A' POST TRIM
DP1	23-WAY AMP - FORD / BLACK	PASSENGER SIDE 'A' POST / 'A' POST TRIM
IC1	20-WAY MULTILOCK 070 / YELLOW	BELOW CENTER CONSOLE GLOVE BOX
IC2	14-WAY MULTILOCK 070 / WHITE	BELOW CENTER CONSOLE GLOVE BOX
RH1	20-WAY MULTILOCK 070 / GREY	BEHIND GLOVE BOX
SC2	10-WAY MULTILOCK 070 / YELLOW	ADJACENT TO STEERING COLUMN MOTOR
SC3	12-WAY MULTILOCK 070 / GREY	RIGHT HAND SIDE OF STEERING COLUMN
SW1	12-WAY MULTILOCK 040 / BLACK	INSIDE STEERING COLUMN COWL
SW2	6-WAY JST / WHITE	CENTER OF STEERING WHEEL

GROUNDS

Ground	Location / Type
BT1AL	EYELET (PAIR) - LEFT HAND LEG / ADJACENT TO BATTERY
CE2	EYELET (SINGLE) / ABOVE RIGHT HAND SIDE OF TRANSMISSION TUNNEL
FC3BL	EYELET (PAIR) - LEFT HAND LEG / TRANSMISSION TUNNEL, LEFT HAND SIDE

CONTROL MODULE PIN OUT INFORMATION (FOLD OUT PAGE)



The following symbols are used to represent values for Control Module Pin Out data:

I	Input	D	Serial and encoded communications	B+	Battery voltage	KHz	Frequency x 1000
O	Output	C	CAN (Network)	V	Voltage (DC)	MS	Milliseconds
SG	Signal Ground	S	SCP Network	Hz	Frequency	MV	Millivolts

CAUTION: The information on this data page is furnished to aid the user in understanding circuit operation. THIS INFORMATION SHOULD BE USED FOR REFERENCE ONLY.

NOTE: The values listed are approximately those that can be expected at the control module connector pins with all circuit connections made and all components connected and fitted. "Active" means a load is applied or a switch is ON; "Inactive" means a load is not applied or a switch is OFF.

REFER TO THE FRONT OF THE BOOK FOR ILLUSTRATIONS DETAILING THE LOCATION AND IDENTIFICATION OF COMPONENTS, RELAYS, CONNECTORS, HARNESES, GROUNDS, VEHICLE CONTROL MODULES AND CONTROL MODULE PINS.

CONTROL MODULE PIN OUT INFORMATION

MAJOR INSTRUMENT PACK

Pin	Description	Active	Inactive
C FC25-24	CAN NETWORK	15 - 1500 Hz	
C FC25-47	CAN NETWORK	15 - 1500 Hz	
O FC26-20	VEHICLE SPEED	22 Hz @ 10 MPH (16 KM/H); 44 Hz @ 20 MPH (32 KM/H) @ B+	

NOTE: REFER TO THE APPENDIX AT THE REAR OF THIS BOOK FOR CAN AND SCP NETWORK MESSAGES.

Fig. 16.2

COMPONENTS

Component	Connector / Type / Color	Location / Access
ANTENNA MOTOR	BT19 / 6-WAY YAZAKI C.S.U. / WHITE	TRUNK / RIGHT HAND SIDE
CD AUTO-CHANGER	IC7 / CD DATA CONNECTOR	TRUNK / RIGHT HAND SIDE
FULL RANGE SPEAKER - DRIVER DOOR	DD19 / 2-WAY GROTE AND HARTMAN MDK / BLACK	DRIVER DOOR CASING
FULL RANGE SPEAKER - PASSENGER DOOR	DP19 / 2-WAY GROTE AND HARTMAN MDK / BLACK	PASSENGER DOOR CASING
MAJOR INSTRUMENT PACK	FC25 / 48-WAY AMP PCB SIGNAL / BLACK FC26 / 24-WAY AMP PCB SIGNAL / BLACK	FASCIA
RADIO / CASSETTE HEAD UNIT	IC8 / COAXIAL CONNECTOR IC10 / 20-WAY MULTILOCK 070 / WHITE IC13 / COAXIAL CONNECTOR IC14 / POWER AMPLIFIER CONNECTOR	CENTER CONSOLE
RADIO ANTENNA	IC12 / COAXIAL CONNECTOR	TRUNK / RIGHT HAND SIDE
RADIO CONTROL SWITCHES (STEERING WHEEL)	SW4 / 3-WAY EPC / BLACK AND WHITE	STEERING WHEEL
RADIO TELEPHONE CONNECTOR	RT20 / 10-WAY MULTILOCK 070 / YELLOW	REAR OF CENTER CONSOLE ASSEMBLY
REAR QUARTER FULL RANGE SPEAKER - DRIVER SIDE	RH31 / 2-WAY GROTE AND HARTMAN MDK / BLACK	INTERIOR REAR QUARTER PANEL
REAR QUARTER FULL RANGE SPEAKER - PASSENGER SIDE	RH30 / 2-WAY GROTE AND HARTMAN MDK / BLACK	INTERIOR REAR QUARTER PANEL

HARNESS-TO-HARNESS CONNECTORS

Connector	Type / Color	Location / Access
AC14	14-WAY MULTILOCK 070 / GREY	FASCIA BOTTOM CONNECTOR MOUNTING BRACKET / RIGHT HAND SIDE
BT1	20-WAY MULTILOCK 070 / WHITE	TRUNK / ABOVE RIGHT HAND REAR WHEEL ARCH
DD1	23-WAY AMP - FORD / BLACK	DRIVER SIDE 'A' POST MOUNTING BRACKET / 'A' POST TRIM
DP1	23-WAY AMP - FORD / BLACK	PASSENGER SIDE 'A' POST / 'A' POST TRIM
IC1	20-WAY MULTILOCK 070 / YELLOW	BELOW CENTER CONSOLE GLOVE BOX
IC2	14-WAY MULTILOCK 070 / WHITE	BELOW CENTER CONSOLE GLOVE BOX
RH1	20-WAY MULTILOCK 070 / GREY	BEHIND GLOVE BOX
SC3	12-WAY MULTILOCK 070 / GREY	RIGHT HAND SIDE OF STEERING COLUMN
SW1	12-WAY MULTILOCK 040 / BLACK	INSIDE STEERING COLUMN COWL
SW2	6-WAY JST / WHITE	CENTER OF STEERING WHEEL

GROUNDS

Ground	Location / Type
FC3BL	EYELET (PAIR) - LEFT HAND LEG / TRANSMISSION TUNNEL, LEFT HAND SIDE
CE2	EYELET (SINGLE) / ABOVE RIGHT HAND SIDE OF TRANSMISSION TUNNEL
BT1AL	EYELET (PAIR) - LEFT HAND LEG / ADJACENT TO BATTERY

CONTROL MODULE PIN OUT INFORMATION (FOLD OUT PAGE)



The following symbols are used to represent values for Control Module Pin Out data:

I	Input	D	Serial and encoded communications	B+	Battery voltage	KHz	Frequency x 1000
O	Output	C	CAN (Network)	V	Voltage (DC)	MS	Milliseconds
SG	Signal Ground	S	SCP Network	Hz	Frequency	MV	Millivolts

CAUTION: The information on this data page is furnished to aid the user in understanding circuit operation. THIS INFORMATION SHOULD BE USED FOR REFERENCE ONLY.

NOTE: The values listed are approximately those that can be expected at the control module connector pins with all circuit connections made and all components connected and fitted. "Active" means a load is applied or a switch is ON; "Inactive" means a load is not applied or a switch is OFF.

REFER TO THE FRONT OF THE BOOK FOR ILLUSTRATIONS DETAILING THE LOCATION AND IDENTIFICATION OF COMPONENTS, RELAYS, CONNECTORS, HARNESSSES, GROUNDS, VEHICLE CONTROL MODULES AND CONTROL MODULE PINS.

CONTROL MODULE PIN OUT INFORMATION

MAJOR INSTRUMENT PACK

Pin	Description	Active	Inactive
C FC25-24	CAN NETWORK	15 - 1500 Hz	
C FC25-47	CAN NETWORK	15 - 1500 Hz	
O FC26-20	VEHICLE SPEED	22 Hz @ 10 MPH (16 KM/H); 44 Hz @ 20 MPH (32 KM/H) @ B+	

NOTE: REFER TO THE APPENDIX AT THE REAR OF THIS BOOK FOR CAN AND SCP NETWORK MESSAGES.

Fig. 16.3

COMPONENTS

Component	Connector / Type / Color	Location / Access
ANTENNA MOTOR	BT19 / 6-WAY YAZAKI C.S.U. / WHITE	TRUNK / RIGHT HAND SIDE
CD AUTO-CHANGER	IC7 / CD DATA CONNECTOR	TRUNK / RIGHT HAND SIDE
MAJOR INSTRUMENT PACK	FC26 / 48-WAY AMP PCB SIGNAL / BLACK FC26 / 24-WAY AMP PCB SIGNAL / BLACK	FASCIA
MID-BASS SPEAKER - DRIVER DOOR	DD19 / 2-WAY GROTE AND HARTMAN MDK / BLACK	DRIVER DOOR
MID-BASS SPEAKER - PASSENGER DOOR	DP19 / 2-WAY GROTE AND HARTMAN MDK / BLACK	PASSENGER DOOR
POWER AMPLIFIER	IC17 / 12-WAY MULTILOCK 070 / WHITE IC18 / 18-WAY MULTILOCK 070 / WHITE	TRUNK / RIGHT HAND SIDE
RADIO / CASSETTE HEAD UNIT	IC8 / COAXIAL CONNECTOR IC10 / 20-WAY MULTILOCK 070 / WHITE IC13 / COAXIAL CONNECTOR IC14 / POWER AMPLIFIER CONNECTOR IC12 / COAXIAL CONNECTOR	CENTER CONSOLE
RADIO ANTENNA	SW4 / 3-WAY EPC / BLACK AND WHITE	TRUNK / RIGHT HAND SIDE
RADIO CONTROL SWITCHES (STEERING WHEEL)	RT20 / 10-WAY MULTILOCK 070 / YELLOW	STEERING WHEEL
RADIO TELEPHONE CONNECTOR	RH25 / 3-WAY MULTILOCK 070 / GREY	REAR OF CENTER CONSOLE ASSEMBLY
REAR QUARTER MID-RANGE SPEAKER (CONVERTIBLE) - DRIVER SIDE	RH31 / 2-WAY GROTE AND HARTMAN MDK / BLACK	INTERIOR REAR QUARTER PANEL
REAR QUARTER MID-RANGE SPEAKER (COUPE) - DRIVER SIDE	RH24 / 3-WAY MULTILOCK 070 / GREY	INTERIOR REAR QUARTER PANEL
REAR QUARTER MID-RANGE SPEAKER (CONVERTIBLE) - PASSENGER SIDE	RH30 / 2-WAY GROTE AND HARTMAN MDK / BLACK	INTERIOR REAR QUARTER PANEL
REAR QUARTER MID-RANGE SPEAKER (COUPE) - PASSENGER SIDE	RH27 / 2-WAY GROTE AND HARTMAN MDK / BLACK	INTERIOR REAR QUARTER PANEL
REAR SUB-WOOFER (CONVERTIBLE) - DRIVER SIDE	RH26 / 2-WAY GROTE AND HARTMAN MDK / BLACK	INTERIOR REAR QUARTER PANEL
REAR SUB-WOOFER (CONVERTIBLE) - PASSENGER SIDE	RH26 / 2-WAY GROTE AND HARTMAN MDK / BLACK RH27 / 2-WAY GROTE AND HARTMAN MDK / BLACK	PARCEL SHELF
SQUAWKER (FASCIA) - DRIVER SIDE	FC39 / 2-WAY MULTILOCK 070 / GREY	FASCIA / DRIVER SIDE
SQUAWKER (FASCIA) - PASSENGER SIDE	FC38 / 2-WAY MULTILOCK 070 / GREY	FASCIA / PASSENGER SIDE
TWEETER - DRIVER DOOR	DD18 / 2-WAY MULTILOCK 040 / BLACK	DRIVER DOOR
TWEETER - PASSENGER DOOR	DP18 / 2-WAY MULTILOCK 040 / BLACK	PASSENGER DOOR

HARNESSTO-HARNESSTO CONNECTORS

Connector	Type / Color	Location / Access
AC14	14-WAY MULTILOCK 070 / GREY	FASCIA BOTTOM CONNECTOR MOUNTING BRACKET / RIGHT HAND SIDE
BT1	20-WAY MULTILOCK 070 / WHITE	TRUNK / ABOVE RIGHT HAND REAR WHEEL ARCH
DD1	23-WAY AMP - FORD / BLACK	DRIVER SIDE 'A' POST MOUNTING BRACKET / 'A' POST TRIM
DP1	23-WAY AMP - FORD / BLACK	PASSENGER SIDE 'A' POST / 'A' POST TRIM
IC1	20-WAY MULTILOCK 070 / YELLOW	BELOW CENTER CONSOLE GLOVE BOX
IC2	14-WAY MULTILOCK 070 / WHITE	BELOW CENTER CONSOLE GLOVE BOX
IC4	4-WAY MULTILOCK 070 / WHITE	TRUNK / LEFT OF ANTENNA ASSEMBLY
RH1	20-WAY MULTILOCK 070 / GREY	BEHIND GLOVE BOX
SC3	12-WAY MULTILOCK 070 / GREY	RIGHT HAND SIDE OF STEERING COLUMN
SW1	12-WAY MULTILOCK 040 / BLACK	INSIDE STEERING COLUMN COWL
SW2	6-WAY JST / WHITE	CENTER OF STEERING WHEEL

GROUNDS

Ground	Location / Type
BT14L	EYELET (PAIR) - LEFT HAND LEG / ADJACENT TO BATTERY
BT1CS	EYELET (SINGLE) / ADJACENT TO BATTERY
CE2	EYELET (SINGLE) / ABOVE RIGHT HAND SIDE OF TRANSMISSION TUNNEL
FC3BL	EYELET (PAIR) - LEFT HAND LEG / TRANSMISSION TUNNEL, LEFT HAND SIDE

CONTROL MODULE PIN OUT INFORMATION (FOLD OUT PAGE)



The following symbols are used to represent values for Control Module Pin Out data:

I	Input	D	Serial and encoded communications	B+	Battery voltage	KHz	Frequency x 1000
O	Output	C	CAN (Network)	V	Voltage (DC)	MS	Milliseconds
SG	Signal Ground	S	SCP Network	Hz	Frequency	MV	Millivolts

CAUTION: The information on this data page is furnished to aid the user in understanding circuit operation. THIS INFORMATION SHOULD BE USED FOR REFERENCE ONLY.

NOTE: The values listed are approximately those that can be expected at the control module connector pins with all circuit connections made and all components connected and fitted. "Active" means a load is applied or a switch is ON; "Inactive" means a load is not applied or a switch is OFF.

REFER TO THE FRONT OF THE BOOK FOR ILLUSTRATIONS DETAILING THE LOCATION AND IDENTIFICATION OF COMPONENTS, RELAYS, CONNECTORS, HARNESSES, GROUNDS, VEHICLE CONTROL MODULES AND CONTROL MODULE PINS.

Fig. 16.4

COMPONENTS

Component	Connector / Type / Color	Location / Access
HANDSET	RT4 / TELEPHONE / PROPRIETARY	CENTER CONSOLE
MICROPHONE	RF9 / 2-WAY MULTILOCK 040 / BLUE	ROOF CONSOLE
TELEPHONE ANTENNA	RT7 / COAXIAL	TRUNK / RIGHT HAND SIDE
TELEPHONE TRANSCEIVER	RT2 / TELEPHONE / PROPRIETARY RT5 / TELEPHONE / PROPRIETARY	CENTER CONSOLE

HARNESS-TO-HARNESS CONNECTORS

Connector	Type / Color	Location / Access
RF1	18-WAY MULTILOCK 070 / YELLOW	RIGHT HAND 'A' POST CONNECTOR MOUNTING BRACKET / 'A' POST TRIM
RT3	TELEPHONE / PROPRIETARY	CENTER CONSOLE
RT6	TELEPHONE / PROPRIETARY	CENTER CONSOLE
RT20	10-WAY MULTILOCK 070 / YELLOW	REAR OF CENTER CONSOLE ASSEMBLY

GROUNDS

Ground	Location / Type
FC2CS	EYELET (SINGLE) / RIGHT HAND 'A' POST
FC4CS	EYELET (SINGLE) / LEFT HAND 'A' POST

REFER TO THE FRONT OF THE BOOK FOR ILLUSTRATIONS DETAILING THE LOCATION AND IDENTIFICATION OF COMPONENTS, RELAYS, CONNECTORS, HARNESSSES, GROUNDS, VEHICLE CONTROL MODULES AND CONTROL MODULE PINS.

CONTROL MODULE PIN OUT INFORMATION

AIRBAG / SRS CONTROL MODULE

Pin	Description	Active	Inactive
I FC29-4	GROUND	GROUND	GROUND
O FC29-5	MAJOR INSTRUMENT PACK AIRBAG MIL	GROUND	B+
D FC29-6	SERIAL COMMUNICATION		
I FC29-7	IGNITION SWITCHED POWER SUPPLY	B+	GROUND
I FC29-8	LH IMPACT SENSOR GROUND SUPPLY STATUS	0 V (NO FAULT)	
I FC29-9	RH IMPACT SENSOR GROUND SUPPLY STATUS	GROUND (NO FAULT)	
I FC29-11	LH IMPACT SENSOR STATUS	GROUND (SHORTED)	B+
I FC29-12	RH IMPACT SENSOR STATUS	GROUND (SHORTED)	B+
O FC30-2	DRIVER SIDE AIRBAG POWER SUPPLY	B+ (SHORTED SAFING SENSOR)	OPEN CIRCUIT
O FC30-3	DRIVER SIDE AIRBAG GROUND SUPPLY	GROUND (SHORTED IMPACT SENSOR)	OPEN CIRCUIT
O FC30-4	PASSENGER SIDE AIRBAG GROUND SUPPLY	GROUND (SHORTED IMPACT SENSOR)	OPEN CIRCUIT
O FC30-5	PASSENGER SIDE AIRBAG POWER SUPPLY	B+ (SHORTED SAFING SENSOR)	OPEN CIRCUIT
O FC30-7	FUSED SUPPLY INTERRUPT	GROUND (FAULT PRESENT)	B+ (NO FAULT)
I FC30-8	DEPLOYMENT BATTERY POWER SUPPLY	B-	B-
I FC30-9	COMMON AIRBAG GROUND SUPPLY	GROUND (SHORTED IMPACT SENSOR)	OPEN CIRCUIT
I FC30-10	COMMON AIRBAG GROUND SUPPLY	GROUND (SHORTED IMPACT SENSOR)	OPEN CIRCUIT
O FC30-11	CODE RETRIEVAL PULSED OUTPUT	GROUND (PULSED)	B+
I FC30-12	GROUND	GROUND	GROUND

Fig. 17.1

COMPONENTS

Component	Connector / Type / Color	Location / Access
AIRBAG - DRIVER SIDE (STEERING WHEEL)	SW11 / 3-WAY EPC / BLACK	CENTER OF STEERING WHEEL
AIRBAG - PASSENGER SIDE	FC74 / 3-WAY EPC / BLACK	LEFT HAND SIDE OF AIRBAG ASSEMBLY
AIRBAG INTERROGATION CONNECTOR	FC40 / 4-WAY MULTILOCK 070 / WHITE	RIGHT HAND 'A' POST / 'A' POST TRIM
AIRBAG / SRS CONTROL MODULE	FC29 / 12-WAY FORD CARD / BLACK FC30 / 12-WAY FORD CARD / GREY	RIGHT HAND 'A' POST / 'A' POST TRIM
IMPACT SENSOR - RH	LF51 / 4-WAY FORD CARD / NATURAL	FRONT UPPER CROSS MEMBER / FORWARD OF RADIATOR
IMPACT SENSOR - LH	LF50 / 4-WAY FORD CARD / NATURAL	FRONT UPPER CROSS MEMBER / FORWARD OF RADIATOR

HARNESSTO-HARNESSTO CONNECTORS

Connector	Type / Color	Location / Access
LF2	8-WAY FORD CARD / BLACK	LEFT HAND 'A' POST CONNECTOR MOUNTING BRACKET / 'A' POST TRIM
SW10	3-WAY EPC / BLACK	INSIDE STEERING COLUMN COWL

GROUNDS

Ground	Location / Type
FC15	EYELET (SINGLE) / TRANSMISSION TUNNEL, RIGHT HAND SIDE

CONTROL MODULE PIN OUT INFORMATION (FOLD OUT PAGE)



The following symbols are used to represent values for Control Module Pin Out data:

I Input	D Serial and encoded communications	B+ Battery voltage	KHz Frequency x 1000
O Output	C CAN (Network)	V Voltage (DC)	MS Milliseconds
SG Signal Ground	S SCP Network	Hz Frequency	MV Millivolts

CAUTION: The information on this data page is furnished to aid the user in understanding circuit operation. THIS INFORMATION SHOULD BE USED FOR REFERENCE ONLY.

NOTE: The values listed are approximately those that can be expected at the control module connector pins with all circuit connections made and all components connected and fitted. "Active" means a load is applied or a switch is ON; "Inactive" means a load is not applied or a switch is OFF.

REFER TO THE FRONT OF THE BOOK FOR ILLUSTRATIONS DETAILING THE LOCATION AND IDENTIFICATION OF COMPONENTS, RELAYS, CONNECTORS, HARNESSES, GROUNDS, VEHICLE CONTROL MODULES AND CONTROL MODULE PINS.

CONTROL MODULE PIN OUT INFORMATION

BODY PROCESSOR MODULE

Pin	Description	Active	Inactive
I FC14-4	BATTERY POWER SUPPLY	B+	B+
O FC14-70	HORN RELAY ACTIVATE	GROUND (HORN SOUNDING)	B+
I FC14-80	BATTERY POWER SUPPLY (LOGIC)	B+	B+

Fig. 18.1

COMPONENTS

Component	Connector / Type / Color	Location / Access
BODY PROCESSOR MODULE	FC14 / 104-WAY AMP EEEC / GREY	PASSENGER SIDE FASCIA / AIRBAG BRACKET
CIGAR LIGHTER	FC42 / 2-WAY AMP / BLACK FC59 / LUCAR RIGHT ANGLE	FORWARD OF GEAR SELECTOR
FASCIA ACCESSORY CONNECTOR	FC51 / 3-WAY AMP SERIES 250 / BLACK	FASCIA / ADJACENT TO RIGHT HAND SIDE OF GLOVE BOX
FUSE BOX - ENGINE COMPARTMENT	LF5 / 10-WAY U.T.A. FUSEBOX / NATURAL LF6 / 10-WAY U.T.A. FUSEBOX / BLACK LF7 / 10-WAY U.T.A. FUSEBOX / GREEN LF8 / 10-WAY U.T.A. FUSEBOX / BLUE LF70 / EYELET	ENGINE COMPARTMENT / LEFT FRONT
FUSE BOX - TRUNK	BT10 / 10-WAY U.T.A. FUSEBOX / NATURAL BT11 / 10-WAY U.T.A. FUSEBOX / BLACK BT12 / 10-WAY U.T.A. FUSEBOX / GREEN BT13 / 10-WAY U.T.A. FUSEBOX / BLUE BT64 / EYELET	TRUNK / ELECTRICAL CARRIER
GARAGE DOOR OPENER (ROOF CONSOLE)	RF11 / HYBRID / WHITE RF10 / 6-WAY MULTILOCK 070 / GREY	ROOF CONSOLE
HORN SWITCHES (STEERING WHEEL)	HP1 / 1-WAY BLADE HP2 / 1-WAY BLADE HP3 / EYELET	CENTER OF STEERING WHEEL
HORN - LH	LF16 / LUCAR RIGHT ANGLE LF17 / LUCAR RIGHT ANGLE	FRONT BUMPER / REAR
HORN - RH	LF14 / LUCAR RIGHT ANGLE LF15 / LUCAR RIGHT ANGLE	FRONT BUMPER / REAR
TRUNK ACCESSORY CONNECTOR	BT25 / 3-WAY AMP SERIES 250 PIN / BLACK	TRUNK / ADJACENT TO BATTERY

RELAYS

Relay	Color / Stripe	Connector / Color	Location / Access
HORN RELAY (#6)	BROWN	BUS	ENGINE COMPARTMENT FUSE BOX
ACCESSORY CONNECTOR RELAY (#6)	BROWN	BUS	TRUNK FUSE BOX

HARNESS-TO-HARNESS CONNECTORS

Connector	Type / Color	Location / Access
BT58	4-WAY ECONOSEAL III HC / BLACK	TRUNK / ABOVE RIGHT HAND REAR WHEEL ARCH
LF60	20-WAY MULTILOCK 070 / WHITE	LEFT HAND 'A' POST CONNECTOR MOUNTING BRACKET / 'A' POST TRIM
RF1	18-WAY MULTILOCK 070 / YELLOW	RIGHT HAND 'A' POST CONNECTOR MOUNTING BRACKET / 'A' POST TRIM
RH14	2-WAY ECONOSEAL III HC / BLACK	REAR OF CENTER CONSOLE ASSEMBLY
SC2	10-WAY MULTILOCK 070 / YELLOW	ADJACENT TO STEERING COLUMN MOTOR
SC3	12-WAY MULTILOCK 070 / GREY	RIGHT HAND SIDE OF STEERING COLUMN
SW1	12-WAY MULTILOCK 040 / BLACK	INSIDE STEERING COLUMN COWL
SW2	6-WAY JST / WHITE	CENTER OF STEERING WHEEL

GROUNDS

Ground	Location / Type
BT2BR	EYELET (PAIR) - RIGHT HAND LEG / TRUNK, RIGHT REAR
FC2BL	EYELET (PAIR) - LEFT HAND LEG / RIGHT HAND 'A' POST
FC2BR	EYELET (PAIR) - RIGHT HAND LEG / RIGHT HAND 'A' POST
FC3BL	EYELET (PAIR) - LEFT HAND LEG / TRANSMISSION TUNNEL, LEFT HAND SIDE
FC3BR	EYELET (PAIR) - RIGHT HAND LEG / TRANSMISSION TUNNEL, LEFT HAND SIDE
FC4BL	EYELET (PAIR) - LEFT HAND LEG / LEFT HAND 'A' POST
FC4BR	EYELET (PAIR) - RIGHT HAND LEG / LEFT HAND 'A' POST
LF1AL	EYELET (PAIR) - LEFT HAND LEG / RIGHT HAND HEADLAMP
LF2BR	EYELET (PAIR) - RIGHT HAND LEG / ENGINE COMPARTMENT, FORWARD OF LEFT HAND HOOD LATCH

CONTROL MODULE PIN OUT INFORMATION (FOLD OUT PAGE)



The following symbols are used to represent values for Control Module Pin Out data:

I	Input	D	Serial and encoded communications	B+	Battery voltage	KHz	Frequency x 1000
O	Output	C	CAN (Network)	V	Voltage (DC)	MS	Milliseconds
SG	Signal Ground	S	SCP Network	Hz	Frequency	MV	Millivolts

CAUTION: The information on this data page is furnished to aid the user in understanding circuit operation. THIS INFORMATION SHOULD BE USED FOR REFERENCE ONLY.

NOTE: The values listed are approximately those that can be expected at the control module connector pins with all circuit connections made and all components connected and fitted. "Active" means a load is applied or a switch is ON; "Inactive" means a load is not applied or a switch is OFF.

REFER TO THE FRONT OF THE BOOK FOR ILLUSTRATIONS DETAILING THE LOCATION AND IDENTIFICATION OF COMPONENTS, RELAYS, CONNECTORS, HARNESSES, GROUNDS, VEHICLE CONTROL MODULES AND CONTROL MODULE PINS.

CONTROL MODULE PIN OUT INFORMATION

REFER TO THE APPENDIX AT THE REAR OF THIS BOOK FOR CAN AND SCP NETWORK MESSAGES.

Fig. 19.1

COMPONENTS

Component	Connector / Type / Color	Location / Access
ABS / TRACTION CONTROL CONTROL MODULE	LF37 / 25-WAY AMP HYBRID / BLACK	ENGINE COMPARTMENT / FRONT LEFT
ADAPTIVE DAMPING CONTROL MODULE	BT69 / 35-WAY AMP / BLACK	TRUNK / ADJACENT TO ELECTRICAL CARRIER
AIR CONDITIONING CONTROL MODULE	AC1 / 28-WAY MULTILOCK 47 / GREY AC2 / 16-WAY MULTILOCK 47 / GREY AC3 / 12-WAY MULTILOCK 47 / GREY AC4 / 22-WAY MULTILOCK 47 / GREY	A/C UNIT / RIGHT HAND SIDE
AIRBAG / SRS CONTROL MODULE	FC29 / 12-WAY FORD CARD / BLACK FC30 / 12-WAY FORD CARD / GREY	RIGHT HAND 'A' POST / 'A' POST TRIM
BODY PROCESSOR MODULE	PC14 / 104-WAY AMP EEEC / GREY	PASSENGER SIDE FASCIA / AIRBAG BRACKET
DATA LINK CONNECTOR	FC53 / 16-WAY AMP OBD2 / BLACK	BELOW DRIVER SIDE FUSE BOX
DOOR CONTROL MODULE - DRIVER	DD10 / 22-WAY FORD 2.8 TIMER / BLUE DD11 / 22-WAY FORD 2.8 TIMER / BLACK	DRIVER DOOR / DOOR CASING
DOOR CONTROL MODULE - PASSENGER	DP10 / 22-WAY FORD 2.8 TIMER / BLUE DP11 / 22-WAY FORD 2.8 TIMER / BLACK	PASSENGER DOOR / DOOR CASING
ENGINE CONTROL MODULE	EM10 / 28-WAY MULTILOCK 040 / GREY EM11 / 16-WAY MULTILOCK 040 / GREY EM12 / 22-WAY MULTILOCK 040 / GREY EM13 / 34-WAY MULTILOCK 040 / GREY EM14 / 12-WAY MULTILOCK 47 / WHITE EM15 / 22-WAY MULTILOCK 47 / WHITE	ENGINE COMPARTMENT / CONTROL MODULE ENCLOSURE
GEAR SELECTOR ILLUMINATION MODULE	FC88 / 10-WAY MULTILOCK 070 / WHITE	FRONT OF GEAR SELECTOR ASSEMBLY
KEY TRANSPONDER MODULE	FC22 / 20-WAY MULTILOCK 040 / GREEN	ADJACENT TO DRIVER SIDE FUSE BOX
MAJOR INSTRUMENT PACK	FC25 / 48-WAY AMP PCB SIGNAL / BLACK FC26 / 24-WAY AMP PCB SIGNAL / BLACK	FASCIA
SEAT CONTROL MODULE - DRIVER	SD3 / 18-WAY FORD 2.8 TIMER / BLACK SD4 / 26-WAY FORD IDC / BLACK SD5 / 10-WAY FORD 2.8 TIMER / BLACK	BELOW SEAT CUSHION
SEAT CONTROL MODULE - PASSENGER	SP3 / 16-WAY FORD 2.8 TIMER / BLACK SP5 / 10-WAY FORD 2.8 TIMER / BLACK	BELOW SEAT CUSHION
SECURITY AND LOCKING CONTROL MODULE	BT40 / 16-WAY FORD 2.8 TIMER / BLACK BT41 / 26-WAY FORD IDC / BLACK RH20 / COAXIAL CONNECTOR	TRUNK / ELECTRICAL CARRIER
TRANSMISSION CONTROL MODULE: AJ26 N/A	EM7 / 88-WAY BOSCH / BLACK	ENGINE COMPARTMENT / CONTROL MODULE ENCLOSURE
TRANSMISSION CONTROL MODULE: AJ26 SC	EM72 / 14-WAY AMP JUNIOR POWER TIMER / BLACK EM73 / 18-WAY AMP JUNIOR POWER TIMER / BLACK	ENGINE COMPARTMENT / CONTROL MODULE ENCLOSURE

HARNESSTO-HARNESSTO CONNECTORS

Connector	Type / Color	Location / Access
AC14	14-WAY MULTILOCK 070 / GREY	FASCIA BOTTOM CONNECTOR MOUNTING BRACKET / RIGHT HAND SIDE
BT1	20-WAY MULTILOCK 070 / WHITE	TRUNK / ABOVE RIGHT HAND REAR WHEEL ARCH
BT2	20-WAY MULTILOCK 070 / WHITE	TRUNK / ABOVE RIGHT HAND REAR WHEEL
DD1	23-WAY AMP - FORD / BLACK	DRIVER SIDE 'A' POST MOUNTING BRACKET/ 'A' POST TRIM
DP1	23-WAY AMP - FORD / BLACK	PASSENGER SIDE 'A' POST / 'A' POST TRIM
EM1	20-WAY MULTILOCK 070 / WHITE	ENGINE COMPARTMENT / ADJACENT TO RIGHT HAND ENCLOSURE
LF40	13-WAY ECONOSEAL III LC / BLACK	ENGINE COMPARTMENT / LEFT HAND ENCLOSURE
RH2	20-WAY MULTILOCK 070 / WHITE	REAR OF CENTER CONSOLE ASSEMBLY
RH12	18-WAY MULTILOCK 070 / YELLOW	REAR OF CENTER CONSOLE ASSEMBLY
SD1	8-WAY MULTILOCK 070 / YELLOW	BELOW DRIVER SEAT
SP1	8-WAY MULTILOCK 070 / YELLOW	BELOW PASSENGER SEAT

GROUND

Ground	Location / Type
FC3BL	EYELET (PAIR) - LEFT HAND LEG / TRANSMISSION TUNNEL, LEFT HAND SIDE

CONTROL MODULE PIN OUT INFORMATION (FOLD OUT PAGE)



The following symbols are used to represent values for Control Module Pin Out data:

I	Input	D	Serial and encoded communications	B+	Battery voltage	KHz	Frequency x 1000
O	Output	C	CAN (Network)	V	Voltage (DC)	MS	Milliseconds
SG	Signal Ground	S	SCP Network	Hz	Frequency	MV	Millivolts

CAUTION: The information on this data page is furnished to aid the user in understanding circuit operation. THIS INFORMATION SHOULD BE USED FOR REFERENCE ONLY.

NOTE: The values listed are approximately those that can be expected at the control module connector pins with all circuit connections made and all components connected and fitted. "Active" means a load is applied or a switch is ON; "Inactive" means a load is not applied or a switch is OFF.

REFER TO THE FRONT OF THE BOOK FOR ILLUSTRATIONS DETAILING THE LOCATION AND IDENTIFICATION OF COMPONENTS, RELAYS, CONNECTORS, HARNESSES, GROUNDS, VEHICLE CONTROL MODULES AND CONTROL MODULE PINS.



This Appendix contains a listing of CAN and SCP Network messages.

Abbreviations

The following abbreviations are used throughout this Appendix:

BPM	Body Processor Module
DIAG	Diagnostics
DDCM	Driver Door Control Module
DSCM	Driver Seat Control Module
INST	Instrument Pack
PDCM	Passenger Door Control Module
PSCM	Passenger Seat Control Module
R	Receive
T	Transmit
SLCM	Security and Locking Control Module



CAN Messages by Node

NODE: Engine Control Module

Transmitted by ECM

Message	Useage
CAN traction acknowledge	Confirms torque reduction for traction control
CAN traction control estimated engine torque	Derived from map of engine characteristics
CAN shift energy management estimated engine torque	Derived from map of engine characteristics
CAN throttle position	Throttle valve position
CAN pedal position	Accelerator pedal position, throttle demand
CAN torque reduction acknowledge	Confirms torque reduction for shift energy management
CAN engine speed	Engine speed
CAN brake pedal pressed	Brake switch status
CAN cruise status	Cruise control system status
CAN park brake status	Indicates whether the parking brake is on
CAN OBD II clear fault codes	Request for ABS and TCM to clear their OBD II DTCs
CAN engine coolant temperature	Engine coolant temperature in Celsius
CAN engine OBD II MIL	MIL control for OBD II DTCs
CAN throttle malfunction red	Red throttle malfunction warnings
CAN throttle malfunction amber	Amber throttle malfunction warnings
CAN ECM fault code MIL status	Indicates whether the ECM DTC should switch MIL on
CAN ECM PECUS flag	PECUS programmed status of ECM
CAN engine fault codes	EMS DTCs, including OBD II P and C codes
CAN fuel used	Derived from injector pulse duration
CAN NWM token ECM	Message for monitoring network status
CAN diagnostic data out – ECM	From external diagnostics device only

**CAN Messages by Node****NODE: Engine Control Module****Received by ECM**

Message	Usage	Source
CAN torque reduction throttle	For traction control – throttle intervention	ABS
CAN fast torque reduction ignition	Fast stability control response – ignition retard	ABS
CAN fast torque reduction cylinder	Fast stability control response – cylinder fuel cutoff	ABS
CAN torque reduction request	For shift energy management	TCM
CAN transmission overload	Protects transmission against excessive torque	TCM
CAN transmission input speed	Transmission input shaft speed	TCM
CAN transmission output speed	Transmission output shaft speed	TCM
CAN torque converter slip	Percentage of torque converter slip	TCM
CAN kickdown	Kickdown status	TCM
CAN traction status	Indicates if the traction control algorithm is functioning	ABS
CAN vehicle reference speed	Vehicle speed based on a standard wheel size	ABS
CAN ABS fault codes	ABS DTCs, including OBD II P and C codes	ABS
CAN OBD II ABS clear acknowledge	Acknowledgment that OBD II ABS DTCs have been cleared	ABS
CAN ABS fault code MIL status	Indicates whether the ABS DTC should switch MIL on	ABS
CAN ABS malfunction	Malfunction information for ABS and brake systems	ABS
CAN side lamp status	Side lamp state for idle speed control	INST
CAN dipped beam status	Dipped beam state for idle speed control	INST
CAN main beam status	Main beam state for idle speed control	INST
CAN oil pressure low	Indicates low engine oil pressure	INST
CAN fuel level damped	Indicates 'damped' level of fuel in tank	INST
CAN fuel level raw	Indicates 'raw – undamped' level of fuel in tank	INST
CAN gear position actual	Actual transmission gear state	TCM
CAN torque converter status	Indicates torque converter lockup	TCM
CAN gear position selected	Position of transmission rotary switch	TCM
CAN gear selection fault	Indicates validity of CAN gear position selected	TCM
CAN transmission shift map	Dynamic shift program currently selected	TCM
CAN transmission oil temperature	Transmission fluid temperature	TCM
CAN transmission malfunction	Transmission malfunction warning	TCM
CAN TCM fault code MIL status	Indicates whether the TCM DTC should switch MIL on	TCM
CAN OBD II TCM clear acknowledge	Acknowledgment that OBD II DTCs have been cleared	TCM
CAN transmission fault codes	TCM DTCs, including OBD II P and C codes	TCM
CAN left front wheel speed	Front left wheel speed	ABS
CAN right front wheel speed	Front right wheel speed	ABS
CAN left rear wheel speed	Rear left wheel speed	ABS
CAN right rear wheel speed	Rear right wheel speed	ABS
CAN NWM token – TCM	Message for monitoring network status	TCM
CAN NWM token – INST	Message for monitoring network status	INST
CAN NWM token – ABS	Message for monitoring network status	ABS
CAN diagnostic data in – ECM	From external diagnostics device only	DIAG



CAN Messages by Node

NODE: Transmission Control Module

Transmitted by TCM

Message	Usage
CAN torque reduction request	For shift energy management
CAN transmission overload	Protects transmission against excessive torque
CAN transmission input speed	Transmission input shaft speed
CAN transmission output speed	Transmission output shaft speed
CAN torque converter slip	Percentage of torque converter slip
CAN kickdown	Kickdown status
CAN gear position actual	Actual transmission gear state
CAN torque converter status	Indicates torque converter lockup
CAN gear position selected	Position of transmission rotary switch
CAN gear selection fault	Indicates validity of CAN gear position selected
CAN transmission shift map	Dynamic shift program currently selected
CAN transmission oil temperature	Transmission fluid temperature
CAN transmission malfunction	Transmission malfunction warning
CAN TCM PECUS flag	PECUS programmed status of TCM
CAN TCM fault code MIL status	Indicates whether the TCM DTC should switch MIL on
CAN OBD II TCM clear acknowledge	Acknowledgment that OBD II DTCs have been cleared
CAN transmission fault codes	TCM DTCs, including OBD II P and C codes
CAN NWM token – TCM	Message for monitoring network status
CAN diagnostic data out – TCM	To external diagnostics device only

Received by TCM

Message	Usage	Source
CAN traction status	Indicates if the traction control algorithm is functioning	ABS
CAN ABS malfunction	Malfunction information for ABS and brake systems	ABS
CAN ABS status	Indicates whether ABS is operating	ABS
CAN shift energy management estimated engine torque	Derived from map of engine characteristics	ECM
CAN throttle position	Throttle valve position	ECM
CAN pedal position	Accelerator pedal position, throttle demand	ECM
CAN torque reduction acknowledge	Confirms torque reduction for shift energy management	ECM
CAN engine speed	Engine speed	ECM
CAN brake pedal pressed	Brake switch status	ECM
CAN cruise status	Cruise control system status	ECM
CAN OBD II clear fault codes	Request for ABS and TCM to clear their OBD II DTCs	ECM
CAN engine coolant temperature	Engine coolant temperature in Celsius	ECM
CAN engine OBD II MIL	MIL control for OBD II DTCs	ECM
CAN throttle malfunction red	Red throttle malfunction warnings	ECM
CAN throttle malfunction amber	Amber throttle malfunction warnings	ECM
CAN ECM fault code MIL status	Indicates whether the ECM DTC should switch MIL on	ECM
CAN engine fault codes	EMS DTCs, including OBD II P and C codes	ECM
CAN left front wheel speed	Front left wheel speed	ABS
CAN right front wheel speed	Front right wheel speed	ABS
CAN NWM token – ECM	Message for monitoring network status	ECM
CAN NWM token – INST	Message for monitoring network status	INST
CAN NWM token – ABS	Message for monitoring network status	ABS
CAN diagnostic data in – TCM	From external diagnostics device only	DIAG

**CAN Messages by Node****NODE: Instrument Pack****Transmitted by INST**

Message	Usage
CAN side lamp status	Side lamp state for idle speed control
CAN dipped beam status	Dipped beam state for idle speed control
CAN main beam status	Main beam state for idle speed control
CAN oil pressure low	Indicates low engine oil pressure
CAN fuel level damped	Indicates 'damped' level of fuel in tank
CAN fuel level raw	Indicates 'raw – undamped' level of fuel in tank
CAN NWM token – INST	Message for monitoring network status
CAN diagnostic data out – INST	To external diagnostics device only

Received by INST

Message	Usage	Source
CAN traction status	Indicates if the traction control algorithm is functioning	ABS
CAN vehicle reference speed	Vehicle speed based on a standard wheel size	ABS
CAN reference distance traveled	Rolling count – based on a standard wheel size	ABS
CAN ABS malfunction	Malfunction information for ABS and brake systems	ABS
CAN engine speed	Engine speed	ECM
CAN brake pedal pressed	Brake switch status	ECM
CAN park brake status	Indicates whether the parking brake is on	ECM
CAN gear position selected	Position of transmission rotary switch	TCM
CAN gear selection fault	Indicates validity of CAN gear position selected	TCM
CAN transmission oil temperature	Transmission fluid temperature	TCM
CAN transmission malfunction	Transmission malfunction warning	TCM
CAN TCM PECUS flag	PECUS programmed status of TCM	TCM
CAN engine coolant temperature	Engine coolant temperature in Celsius	ECM
CAN engine OBD II MIL	MIL control for OBD II DTCs	ECM
CAN throttle malfunction red	Red throttle malfunction warnings	ECM
CAN throttle malfunction amber	Amber throttle malfunction warnings	ECM
CAN ECM PECUS flag	PECUS programmed status of ECM	ECM
CAN fuel used	Derived from injector pulse duration	ECM
CAN right rear wheel speed	Rear right wheel speed	ABS
CAN NWM token – ECM	Message for monitoring network status	ECM
CAN NWM token – TCM	Message for monitoring network status	TCM
CAN NWM token – ABS	Message for monitoring network status	ABS
CAN diagnostic data in – INST	From external diagnostics device only	DIAG



CAN Messages by Node

NODE: ABS / Traction Control Control Module

Transmitted by ABS/TC CM

Message	Usage
CAN torque reduction throttle	For traction control – throttle intervention
CAN fast torque reduction ignition	Fast stability control response – ignition retard
CAN fast torque reduction cylinder	Fast stability control response – cylinder fuel cut off
CAN traction status	Indicates if the traction control algorithm is functioning
CAN vehicle reference speed	Vehicle speed based on a standard wheel size
CAN reference distance traveled	Rolling count – based on a standard wheel size
CAN ABS fault codes	ABS DTCs, including OBD II P and C codes
CAN OBD II ABS clear acknowledge	Acknowledgment that OBD II ABS DTCs have been cleared
CAN ABS fault code MIL status	Indicates whether the ABS DTC should switch MIL on
CAN ABS malfunction	Malfunction information for ABS and brake systems
CAN ABS status	Indicates whether ABS is operating
CAN left front wheel speed	Front left wheel speed
CAN right front wheel speed	Front right wheel speed
CAN left rear wheel speed	Rear left wheel speed
CAN right rear wheel speed	Rear right wheel speed
CAN NWM token – ABS	Message for monitoring network status
CAN diagnostic data out – ABS	From external diagnostics device only

Received by ABS/TC CM

Message	Usage	Source
CAN traction acknowledge	Confirms torque reduction for traction control	ECM
CAN traction control estimated engine torque	Derived from map of engine characteristics	ECM
CAN transmission input speed	Transmission input shaft speed	TCM
CAN transmission output speed	Transmission output shaft speed	TCM
CAN torque converter slip	Percentage of torque converter slip	TCM
CAN kickdown	Kickdown status	TCM
CAN throttle position	Throttle valve position	ECM
CAN pedal position	Accelerator pedal position, throttle demand	ECM
CAN engine speed	Engine speed	ECM
CAN brake pedal pressed	Brake switch status	ECM
CAN OBD II clear fault codes	Request for ABS and TCM to clear their OBD II DTCs	ECM
CAN gear position actual	Actual transmission gear state	TCM
CAN torque converter status	Indicates torque converter lockup	TCM
CAN transmission shift map	Dynamic shift program currently selected	TCM
CAN transmission malfunction	Transmission malfunction warning	TCM
CAN transmission fault codes	TCM DTCs, including OBD II P and C codes	TCM
CAN engine OBD II MIL	MIL control for OBD II DTCs	ECM
CAN throttle malfunction red	Red throttle malfunction warnings	ECM
CAN throttle malfunction amber	Amber throttle malfunction warnings	ECM
CAN ECM fault code MIL status	Indicates whether the ECM DTC should switch MIL on	ECM
CAN engine fault codes	EMS DTCs, including OBD II P and C codes	ECM
CAN NWM token – ECM	Message for monitoring network status	ECM
CAN NWM token – TCM	Message for monitoring network status	TCM
CAN NWM token – INST	Message for monitoring network status	INST
CAN diagnostic data in – ABS	From external diagnostics device only	DIAG



CAN Messages by Node

NODE: Gear Selector Module (listen only)

Received by Gear Selector Module

Message	Usage	Source
CAN gear position selected	Gear selector indicator illumination	TCM
CAN gear selection fault		TCM



CAN Message Matrix

Message	ABS	TCM	ECM	INST	Gear Selector	Diagnostics
CAN torque reduction throttle	T		R			
CAN fast torque reduction ignition	T		R			
CAN fast torque reduction cylinder	T		R			
CAN traction acknowledge	R		T			
CAN traction control estimated engine torque	R		T			
CAN torque reduction request		T	R			
CAN transmission overload		T	R			
CAN transmission input speed	R	T	R			
CAN transmission out speed	R	T	R			
CAN torque converter slip	R	T	R			
CAN kickdown	R	T	R			
CAN traction status	T	R	R	R		
CAN vehicle reference speed	T		R	R		
CAN reference distance traveled	T			R		
CAN ABS fault codes	T		R			
CAN OBD II ABS clear acknowledge	T		R			
CAN ABS fault code MIL status	T		R			
CAN ABS malfunction	T	R	R	R		
CAN ABS status	T	R				
CAN shift energy management estimated engine torque		R	T			
CAN throttle position	R	R	T			
CAN pedal position	R	R	T			
CAN torque reduction acknowledge		R	T			
CAN engine speed	R	R	T	R		
CAN brake pedal pressed	R	R	T	R		
CAN cruise status		R	T			
CAN park brake status			T	R		
CAN OBD II clear fault codes	R	R	T			
CAN side lamp status			R	T		
CAN dipped beam status			R	T		
CAN main beam status			R	T		
CAN oil pressure low			R	T		
CAN fuel level raw			R	T		
CAN fuel level damped			R	T		
CAN gear position actual	R	T	R			
CAN torque converter status	R	T	R			
CAN gear position selected	R	T	R	R	R	
CAN gear selection fault	R	T	R	R	R	
CAN transmission shift map	R	T	R			
CAN transmission oil temperature		T	R	R		
CAN transmission malfunction	R	T	R	R		
CAN TCM PECUS flag		T		R		
CAN TCM fault code MIL status		T	R			
CAN OBD II TCM clear acknowledge		T	R			
CAN transmission fault codes	R	T	R			
CAN engine coolant temperature		R	T	R		
CAN engine OBD II MIL	R	R	T	R		
CAN throttle malfunction red	R	R	T	R		
CAN throttle malfunction amber	R	R	T	R		
CAN ECM fault code MIL status	R	R	T			
CAN ECM PECUS flag			T	R		
CAN engine fault codes	R	R	T			
CAN fuel used			T	R		
CAN left front wheel speed	T	R	R			
CAN right front wheel speed	T	R	R			
CAN left rear wheel speed	T		R			
CAN right rear wheel speed	T		R	R		



Message	ABS	TCM	ECM	INST	Gear Selector	Diagnostics
CAN NWM token – ECM	R	R	T	R		
CAN NWM token – TCM	R	T	R	R		
CAN NWM token – INST	R	R	R	T		
CAN NWM token – ABS	T	R	R	R		
CAN diagnostic data in – ECM			R			T
CAN diagnostic data in – TCM		R				T
CAN diagnostic data in – INST				R		T
CAN diagnostic data in – ABS	R					T
CAN diagnostic data out – ECM			T			R
CAN diagnostic data out – TCM		T				R
CAN diagnostic data out – INST				T		R
CAN diagnostic data out – ABS	T					R



SCP Message Matrix

#	Message Name	INST	BPM	DDCM	PDCM	DSCM	PSCM	SLCM
1	Vehicle speed	T	R	R				R
2	Brake pedal pressed	T	R					
3	SLCM not programmed	R						T
4	BPM not programmed	R	T					
5	DDCM not programmed	R		T				
6	DSCM not programmed	R				T		
7	PDCM not programmed	R			T			
8	PSCM not programmed	R					T	
9	Left hand drive vehicle		T	R	R			R
10	Valet mode OFF		T					R
11	Non-convertible vehicle		T					R
12	Right hand drive vehicle		T	R	R			R
13	Valet mode ON		T					R
14	Convertible vehicle		T					R
15	Request vehicle drive side		R	T				
16	Request valet mode status		R					T
17	Request convertible status		R					T
18	Reverse gear selected	T	R	R	R	R	R	R
19	Not-in-park switch – inactive		T	R	R	R	R	
20	Not-in-park switch – active		T	R	R	R	R	
21	Request not-in-park switch status		R			T		
22	Request not-in-park switch status		R				T	
23–58	Diagnostic messages							
59	Charging OK	T				R	R	
60	Inertia switch inactive		T	R	R			R
61	Inertia switch active		T	R	R			R
62	Request inertia switch status		R	T				
63	Request inertia switch status		R		T			
64	Ignition status	R	T	R	R	R	R	R
65	Key not-in-ignition		T	R	R			R
66	Key in-ignition		T	R	R			R
67	Request ignition status		R					T
68	Request ignition status	T	R					
69	Request ignition status		R	T				
70	Request ignition status		R			T		
71	Request ignition status		R		T			
72	Request ignition status		R				T	
73	Request key-in status		R					T
74	Request key-in status		R	T				
75	Request key-in status		R			T		
76	Request key-in status		R		T			
77	Seat belt telltale OFF	R				T		
78	Low washer fluid warning OFF	R	T					
79	Convertible top latch warning OFF	R						T
80	Seat belt telltale ON	R				T		
81	Low washer fluid warning ON	R	T					
82	Convertible top latch warning ON	R						T
83	Request washer fluid status	T	R					
84	Request convertible top latch status	T						R
85	Security audible indication		R					T
86	Remote panic		R	R	R			T
87	Security disarm		R	R	R			T
88	Glass break fault		T					R
89	Security armed		R	R	R			T
90	Key valid		T					R



#	Message Name	INST	BPM	DDCM	PDCM	DSCM	PSCM	SLCM
91	Glass break detected		T					R
92	Request security arm status		T					R
93	Request security arm status			T				R
94	Request security arm status				T			R
95	Seat belt chime OFF		R			T		
96	Seat belt chime ON		R			T		
97	Request seat belt chime status		T			R		
98-165	Diagnostic messages							
166	Recall memory 1		R	T	R	R		
167	Recall memory 2		R	T	R	R		
168	Save memory 1		R	T	R	R		
169	Save memory 2		R	T	R	R		
170	DDCM memory 1 recalled		R	T				
171	DSCM memory 1 recalled		R			T		
172	PDCM memory 1 recalled		R		T			
173	DDCM memory 2 recalled		R	T				
174	DSCM memory 2 recalled		R			T		
175	PDCM memory 2 recalled		R		T			
176	Park fold-back mirrors			T		R	R	
177	Unfold fold-back mirrors			T		R	R	
178	Stop driver mirror			T	R			
179	Stop passenger mirror			T	R			
180	Driver mirror up			T	R			
181	Passenger mirror up			T	R			
182	Driver mirror down			T	R			
183	Passenger mirror down			T	R			
184	Passenger mirror right			T	R			
185	Passenger mirror left			T	R			
186	Unlock driver door			R	T			
187	Unlock passenger door			T	R			
188	Remote unlock	R		R	R			T
189	Remote trunk release	R						T
190	Lock front doors	R		T				
191	Lock front doors	R			T			
192	Remote superlock			R	R			T
193	Superlock driver door					T		
194	Superlock passenger door			T				
195	Remote lock	R						T
196	Vehicle unlocked	R		T				R
197	Driver door unlocked	R		R	R			T
198	Passenger door unlocked	R			R			T
199	Driver lock switch status	R		T				R
200	Passenger lock switch status	R			T			R
201	Driver door unsuperlocked	R		T				
202	Passenger door unsuperlocked	R			T			
203	Vehicle locked	R		T				R
204	Driver door locked	R		R	R			T
205	Passenger door locked	R		R	R			T
206	Driver door superlocked	R		T				
207	Passenger door superlocked	R			T			
208	Request vehicle lock status			R				T
209	Request driver door lock status			T				R
210	Request passenger door status				T			R
211	Request driver key barrel status			R				T
212	Request driver key barrel status			R	T			

(continued)



SCP Message Matrix

#	Message Name	INST	BPM	DDCM	PDCM	DSCM	PSCM	SLCM
213	Request passenger key barrel status (deleted)				R			T
214	Request passenger key barrel status (deleted)			T	R			
215	Request superlock status		T	R	R			
216	Open trunk		T					R
217	Hood closed	R	T					R
218	Driver door closed	R	R	T		R		R
219	Passenger door closed	R	R			T	R	R
220	Trunk closed	R	R					T
221	Stop fuel filler flap open		T					R
222	Convertible top latch status		T					
223	Hood ajar	R	T					R
224	Driver door ajar	R	R	T		R		R
225	Passenger door ajar	R	R		T		R	R
226	Trunk ajar	R	R					T
227	Open fuel filler flap		T					R
228	Request hood ajar status		R					T
229	Request driver door ajar status			R				T
230	Request driver door status		T	R				
231	Request driver door ajar status			R		T		
232	Request passenger door ajar status				R			T
233	Request trunk ajar status		T					R
234	Request convertible top latch switches status		R					T
235	Driver seat heater telltale OFF		R			T		
236	Passenger seat heater telltale OFF		R				T	
237	Driver seat heater telltale ON		R			T		
238	Passenger seat heater telltale ON		R				T	
239	Request driver heater telltale status		T			R		
240	Request passenger heater telltale status		T				R	
241	Stop global window open		R	R	R			T
242	Stop global window close		R	R	R			T
243	Position driver window			R				T
244	Position passenger window				R			T
245	Position rear quarters		R					T
246	Driver window position			T				R
247	Passenger window position				T			R
248	Stop passenger window open			T	R			
249	Stop convertible top open		T					R
250	Stop passenger window close			T	R			
251	Stop convertible top close		T					R
252	Open passenger window			T	R			
253	Open convertible top		T					R
254	Close passenger window			T	R			
255	Close convertible top		T					R
256	Request driver window position			R				T
257	Request passenger window position				R			T
258	Request driver and passenger window switch status			R	T			
259	Driver seat heater switch active		T			R		
260	Passenger seat heater switch active		T				R	
261	Front bulb failure	R	T					
262	Rear bulb failure	R						T
263	Front bulbs OK	R	T					
264	Rear bulbs OK	R						T
265	Request front bulb fail status	T	R					
266	Request rear bulb fail status	T						R
267	Rear fog lamps OFF		T					R
268	Remote headlamp convenience OFF		R					T



#	Message Name	INST	BPM	DDCM	PDCM	DSCM	PSCM	SLCM
269	Rear fog lamps ON		T					R
270	Remote headlamp convenience ON		R					T
271	Dip beam OFF	R	T					
272	Side lamps OFF	R	T					
273	Hazard warning OFF	R	T					
274	Left DI lamp OFF	R	T					
275	Right DI lamp OFF	R	T					
276	Main beam OFF	R	T					
277	Rear fog lamps OFF		R					T
278	Main beam flash OFF		T					R
279	Request rear fog switch status		R					T
280	Request remote headlamp convenience status		T					R
281	Dip beam ON	R	T					
282	Side lamps ON	R	T					
283	Hazards ON	R	T					
284	Left DI lamp ON	R	T					
285	Right DI lamp ON	R	T					
286	Main beam ON	R	T					
287	Rear fog lamps ON		R					T
288	Main beam flash ON		T					R
289	Request dip beam status	T	R					
290	Request side lamps status	T	R					
291	Request left DI status	T	R					
292	Request right DI status	T	R					
293	Request main beam status	T	R					
294	Request hazard warning status	T	R					
295	Request rear fog lamps status		T					R
296	Interior lamps OFF	R	T					
297	Interior lamps ON	R	T					
298	Request interior lighting status	T	R					
299	Valet mode message OFF	R	T					
300	Recoding keying message OFF	R						T
301	Valet mode message	R	T					
302	Recoding keying message	R						T
303-356	Diagnostic messages							
357	Wake up (SLCM)							T
358	Wake up (BPM)		T					
359	Wake up (INST)	T						
360	Wake up (DDCM)			T				
361	Wake up (DSCM)					T		
362	Wake up (PDCM)				T			
363	Wake up (PSCM)						T	
364	Network awake (SLCM)	R	R	R	R	R	R	T
365	Network awake (BPM)	R	T	R	R	R	R	R
366	Network awake (INST)	T	R	R	R	R	R	R
367	Network awake (DDCM)	R	R	T	R	R	R	R
368	Network awake (DSCM)	R	R	R	R	T	R	R
369	Network awake (PDCM)	R	R	R	T	R	R	R
370	Network awake (PSCM)	R	R	R	R	R	T	R
371	SLCM entering sleep mode	R	R	R	R	R	R	T
372	BPM entering sleep mode	R	T	R	R	R	R	R
373	INST entering sleep mode	T	R	R	R	R	R	R
374	DDCM entering sleep mode	R	R	T	R	R	R	R
375	DSCM entering sleep mode	R	R	R	R	T	R	R
376	PDCM entering sleep mode	R	R	R	T	R	R	R
377	PSCM entering sleep mode	R	R	R	R	R	T	R

Free Manuals Download Website

<http://myh66.com>

<http://usermanuals.us>

<http://www.somanuals.com>

<http://www.4manuals.cc>

<http://www.manual-lib.com>

<http://www.404manual.com>

<http://www.luxmanual.com>

<http://aubethermostatmanual.com>

Golf course search by state

<http://golfingnear.com>

Email search by domain

<http://emailbydomain.com>

Auto manuals search

<http://auto.somanuals.com>

TV manuals search

<http://tv.somanuals.com>