

INSTRUCTION BOOK



Model DC 3050

JANOME

IMPORTANT SAFETY INSTRUCTIONS

When using an electrical appliance, basic safety precautions should always be followed, including the followings:

Read all instructions before using this appliance.

DANGER— To reduce the risk of electric shock:

1. An appliance should never be left unattended when plugged in. Always unplug this sewing machine from the electric outlet immediately after using and before cleaning.
2. Always unplug before replacing a sewing machine bulb. Replace bulb with same type rated 12 Volts, 5 Watts.

WARNING— To reduce the risk of burns, fire, electric shock, or injury to persons:

1. Do not allow to be used as a toy. Close attention is necessary when this sewing machine is used by or near children.
2. Use this appliance only for its intended use as described in this owner's manual.
Use only attachments recommended by the manufacturer as contained in this owner's manual.
3. Never operate this sewing machine if it has a damaged cord or plug, if it is not working properly, if it has been dropped or damaged, or dropped into water.
Return this sewing machine to the nearest authorized dealer or service center for examination, repair, electrical or mechanical adjustment.
4. Never operate the appliance with any air opening blocked. Keep ventilation openings of this sewing machine and foot controller free from accumulation of lint, dust and loose cloth.
5. Never drop or insert any object into any opening.
6. Do not use outdoors.
7. Do not operate where aerosol (spray) products are being used or where oxygen is being administered.
8. To disconnect, turn all controls to the off ("O") position, then remove plug from outlet.
9. Do not unplug by pulling on cord. To unplug, grasp the plug, not the cord.
10. Keep fingers away from all moving parts. Special care is required around the sewing machine needle.
11. Always use the proper needle plate. The wrong plate can cause the needle to break.
12. Do not use bent needles.
13. Do not pull or push fabric while stitching. It may deflect the needle causing it to break.
14. Switch this sewing machine off ("O") when making any adjustment in the needle area, such as threading the needle, changing the needle, threading the bobbin or changing the presser foot, and the like.
15. Always unplug this sewing machine from the electrical outlet when removing covers, lubricating, or when making any other adjustments mentioned in this owner's manual.

SAVE THESE INSTRUCTIONS

The design and specifications are subject to change without a prior notice.

TABLE OF CONTENTS

KNOW YOUR MACHINE

Name of Parts	2
Standard Accessories	3
Extension table	3

GETTING READY TO SEW

Connecting the Power Supply	4
Controlling Sewing Speed	4
Speed control slider	4
Foot control	4
Function Buttons and Keys	5
Reverse button	5
Auto-Lock button	5
Up/Down needle button	5
Mode key	6
Direct pattern selection	6
Dropping the Feed Dog	7
Changing the Presser Foot	7
Detaching and Attaching the Foot Holder	7
Raising and Lowering the Presser Foot	8
Balancing Thread Tension	8
Auto tension	8
Manual tension adjustment	8
Changing Needles	9
Winding the Bobbin	10
Removing the bobbin	10
Setting the spool of thread	10
Additional spool pin	10
Threading for bobbin winding	10
Inserting the bobbin	11
Threading the Machine	12
Built-in Needle Threader	13
Drawing Up the Bobbin Thread	13

BASIC STITCHES

Straight Stitch	14
To sew	14
Changing sewing direction	14
Securing a seam	14
Altering the stitch length	15
Altering the needle drop position	15
Using the seam guide lines	16
To sew from the edge of thick fabric	16
Variety of Straight Stitches and Recommended Feet	17
Zigzag Stitches	18
Altering the stitch width	18
Altering the stitch length	18
Variety of Overcasting Stitches	19
Overcasting with zigzag stitch	19
Multiple zigzag stitches (Tricot stitch)	19
Overcasting stitch	19
Double overedge stitch	20
Buttonholes	21
Variety of buttonholes	21
Square buttonhole	21
Altering the buttonhole width	24
Altering buttonhole stitch density	24
Double layer buttonhole	24
Round end and keyhole buttonholes	25
Altering the buttonhole width	25
Corded buttonhole	26

Button Sewing	27
Darning	28
To sew a shorter darning	28
To adjust the evenness of darning	28
Zipper Sewing	29
Attaching the zipper foot	29
Fabric preparation for zipper sewing	29
To sew	29
Blind Hem	30

DECORATIVE STITCHES

Knit stitch	32
Shell Tucking	32
Satin Stitches	32
Applique Sewing	33
Scallop Stitch	33
Patchwork	33
Smocking	34
Fagoting	34
Cross Stitch	34
Pattern Combination	35
Correcting Distorted Stretch Patterns	36

CARE AND MAINTENANCE

Replacing the Light Bulb	36
Cleaning the Hook Race	37
Inserting the bobbin holder	37
Problems and Warning Signals	38
Troubleshooting	39

KNOW YOUR MACHINE

Name of Parts

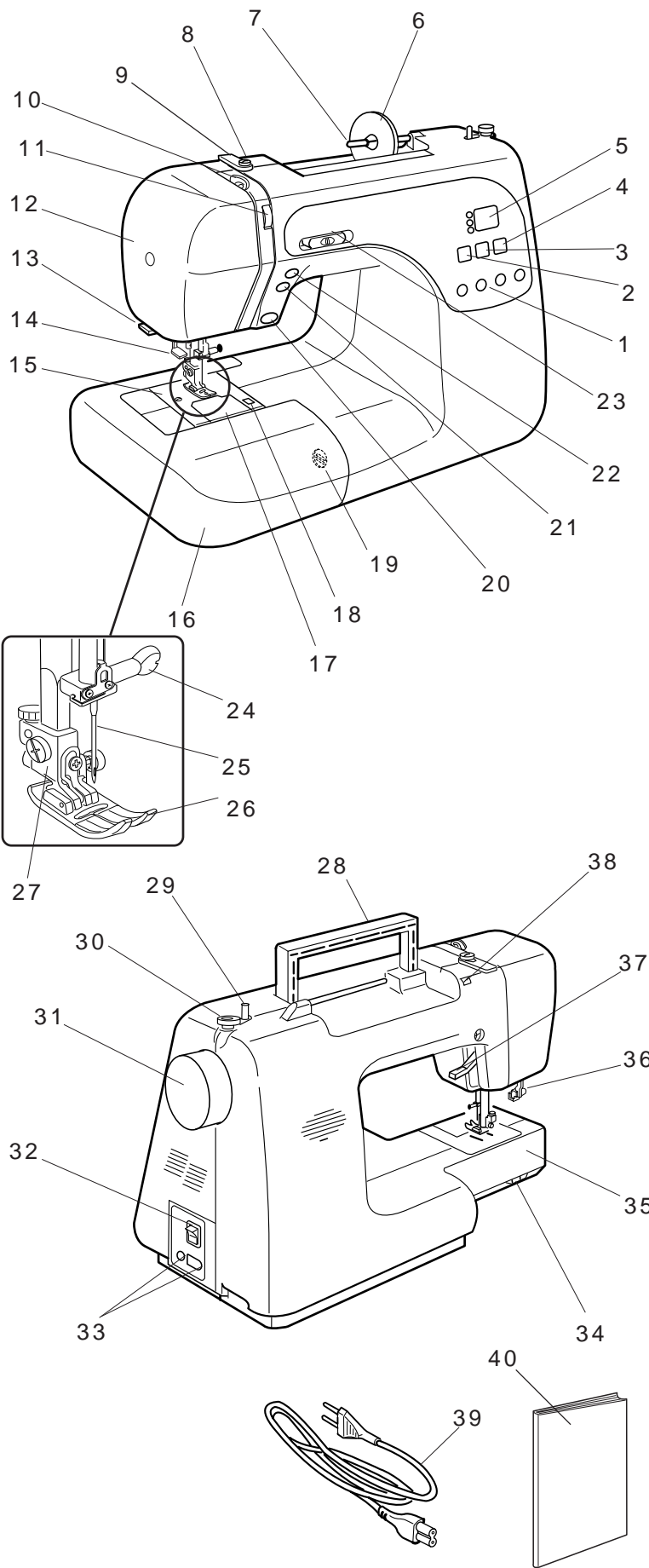

1. Direct pattern selection buttons
2. Mode selection button
3. Plus (+) button
4. Minus (-) button
5. Indicator window
6. Spool holder (large)
7. Spool pin
8. Bobbin winding thread guide
9. Thread guide
10. Thread take-up lever
11. Tension regulating dial
12. Face plate
13. Thread cutter
14. Needle threader
15. Needle plate
16. Extension table (accessory storage)
17. Hook cover plate
18. Hook cover plate release button
19. Stitch balance adjusting dial
20. Reverse button
21. Auto-lock button
22. Up/down needle button
23. Speed control slider
24. Needle clamp screw
25. Needle
26. Zigzag foot A
27. Foot holder
28. Carrying handle
29. Bobbin winder spindle
30. Bobbin winder stopper
31. Hand wheel
32. Power switch
33. Machine sockets
34. Drop-feed lever
35. Free arm
36. Buttonhole lever
37. Presser foot lifter
38. Hole for additional spool pin
39. Power supply cord
40. Instruction book

Standard Accessories

The standard accessories are stored in the extension table.

- ① Extension table
- ② Standard accessories

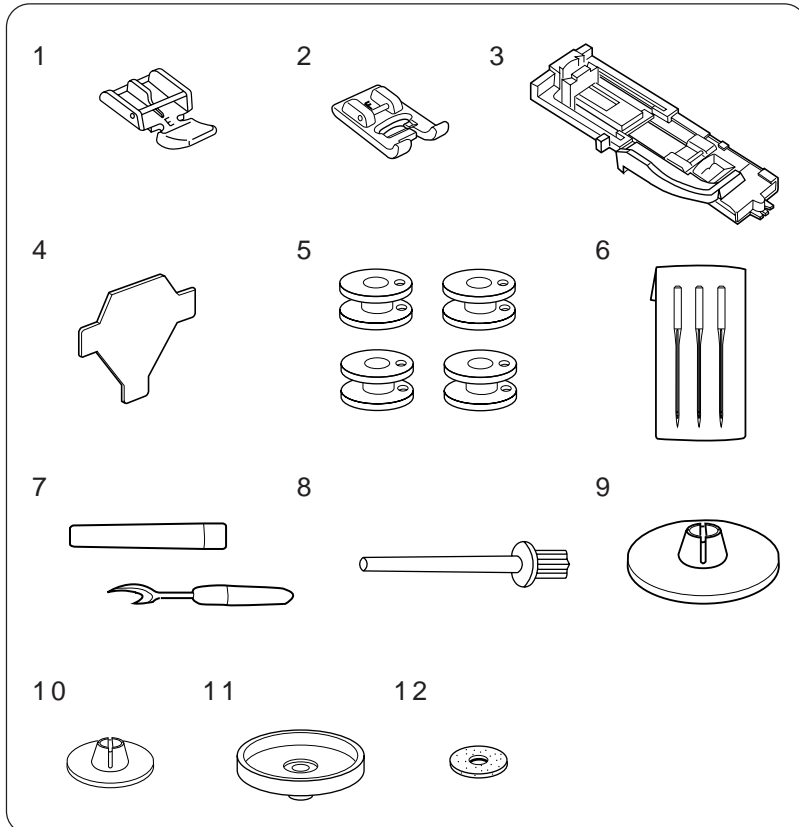
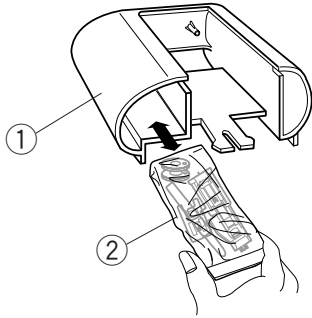

- 1. Zipper Foot E
- 2. Satin Stitch Foot F
- 3. Automatic Buttonhole Foot R
- 4. Screwdriver
- 5. Bobbins
- 6. Set of Needles
- 7. Seam Ripper
- 8. Additional spool pin
- 9. Spool Holder (Large)
- 10. Spool Holder (Small)
- 11. Spool stand
- 12. Felt

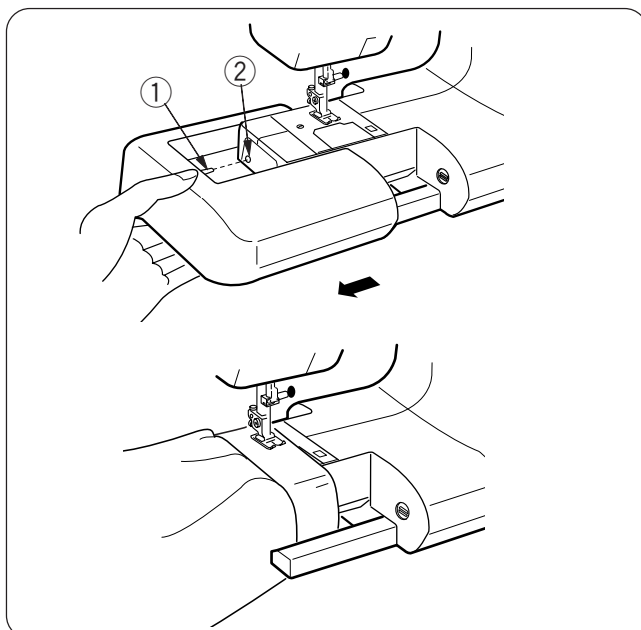

Extension table

The extension table provides an added sewing surface and can be easily removed for free arm sewing.

- **Detaching extension table**
Pull the table away from the machine, as illustrated.
- **Free arm sewing**
Free arm sewing is useful for darning socks or mending knees, elbows or areas of wear in children's clothes.
- **Attaching extension table**
Push the extension table until it snaps into the machine.
 - ① Projection
 - ② Hole

GETTING READY TO SEW

Connecting the Power Supply

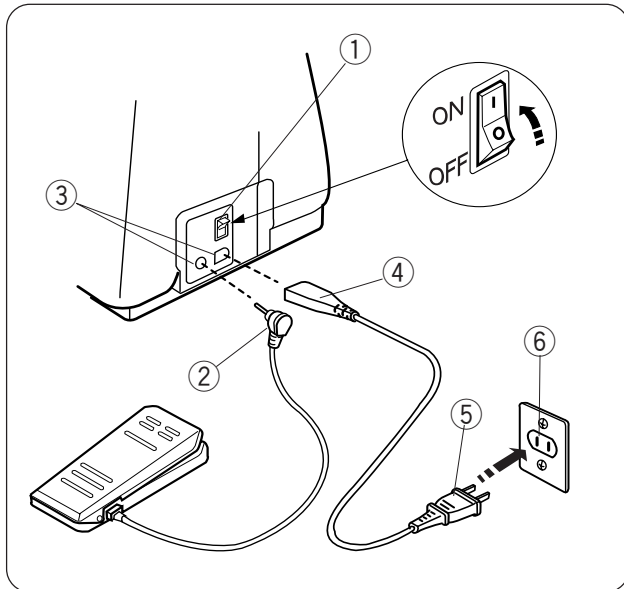

Turn off the power switch.

Insert the foot control plug into the machine socket.

Insert the machine plug into the machine socket.

Insert the power supply plug into the wall outlet.

Turn on the power switch.

- ① Power Switch
- ② Foot Control Plug
- ③ Machine Socket
- ④ Machine Plug
- ⑤ Power Supply Plug
- ⑥ Wall Outlet

For Your Safety:

While in operation, always keep your eyes on the sewing area, and do not touch any moving parts such as the thread take-up lever, handwheel or needle. Always turn off the power switch and unplug from the power supply:

- when leaving the machine unattended.
- when attaching or removing parts.
- when cleaning the machine.

Do not place anything on the foot control, otherwise the machine will run intermittently.

When the power is turned on, the indicator window will show a test pattern then will indicate 01.

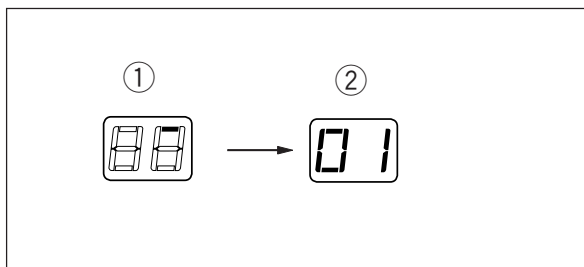

Operating Instructions:

The symbol "O" of a switch indicates the "off" position of a switch.

For appliances with a polarized plug (one blade wider than the other). To reduce the risk of electric shock, this plug is intended to fit in a polarized outlet only one way. If it does not fit fully in the outlet, reverse the plug. If it still does not fit, contact a qualified electrician to install the proper outlet. Do not modify the plug in any way.

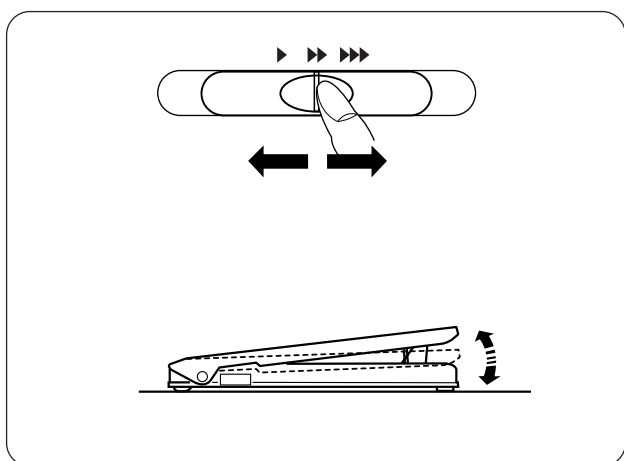

Controlling Sewing Speed

Speed control slider

You can limit the maximum sewing speed with the speed control slider according to your sewing needs.

To increase sewing speed, slide it to the right.

To decrease sewing speed, slide it to the left.

Foot control

Pressing on the foot control can vary sewing speed. The harder you press the foot control, the faster the machine runs.

NOTES:

The machine runs at the maximum speed set by the speed control slider when the foot control is fully depressed.

Keep the foot control free from accumulation of lint, dust and loose cloth.

Do not place anything on the foot control.

Operating Instructions:

Foot controller Model 21371 is for use with sewing machine model DC3050.

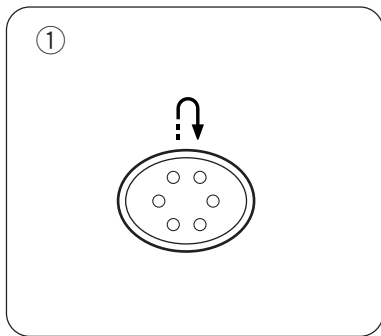
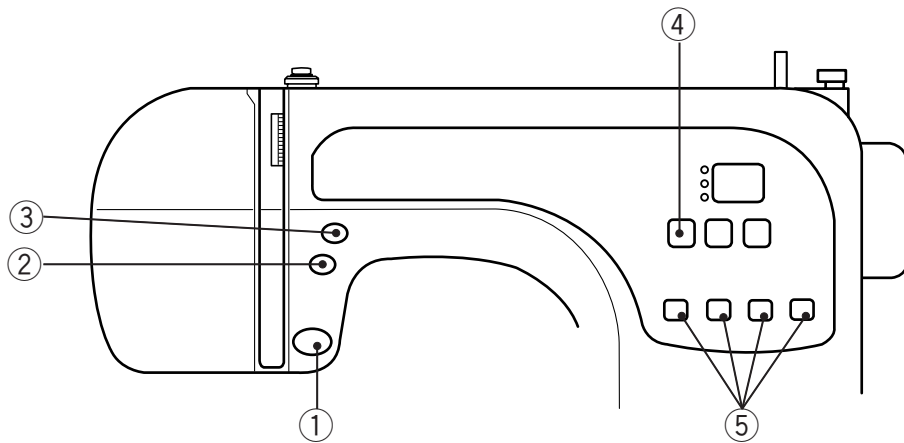

Function Buttons and Keys

① Reverse button

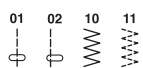
When stitch pattern 01, 02, 10 or 11  has been selected, the machine will sew in reverse while the reverse button is pressed.

If you press the reverse button when sewing any other stitches, the machine will immediately sew locking stitches and automatically stop.

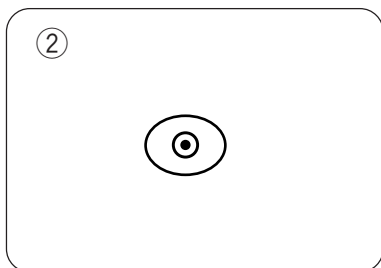

② Auto-Lock button

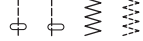
When stitch pattern 01, 02, 10 or 11  has been selected, the machine will immediately sew locking stitches and automatically stop when the auto-lock button is pressed.

When sewing any other stitches, the machine will sew locking stitches at the end of the pattern being sewn and automatically stop.

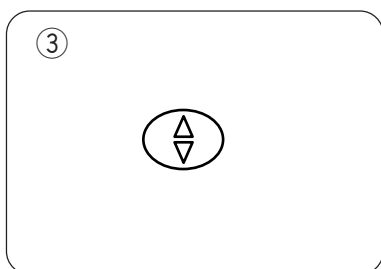

③ Up/Down needle button

Press this button to bring the needle up or down.

The machine will stop with the needle up or down depending on the needle position determined by this button.

④



(1)

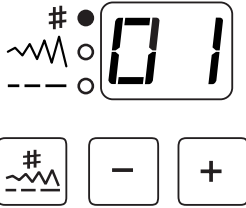

(2)

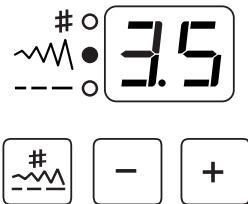

(3)



⑤

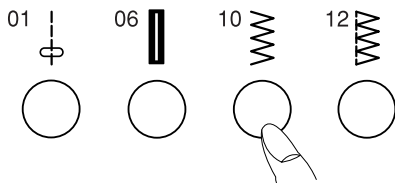

④ Mode key

Each time you press this key the mode will change in the following order:

(1) Pattern selection mode

The green light on the top will be on.

To select the pattern, press the key until the pattern number of the desired stitch is indicated (see the stitch chart below).

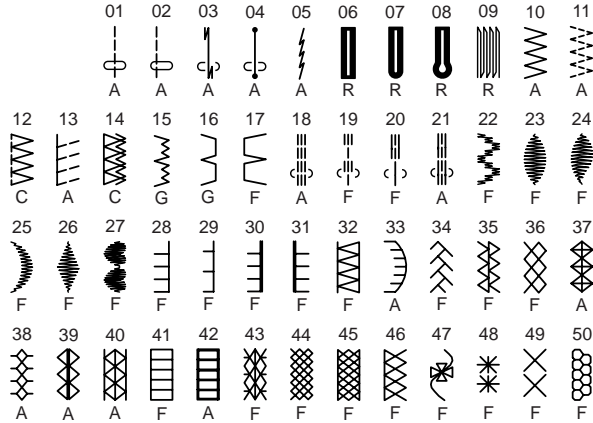

(2) Stitch width adjusting mode

The green light in the middle will light up.

The stitch width of the selected pattern will be indicated.

To alter the stitch width, press the key.

(3) Stitch length adjusting mode

The green light on the bottom will light up.

The stitch length of the selected pattern will be indicated.

To alter the stitch length, press the key.

⑤ Direct pattern selection

The 4 most commonly used stitches can be directly selected by pressing the button under the pattern icon.

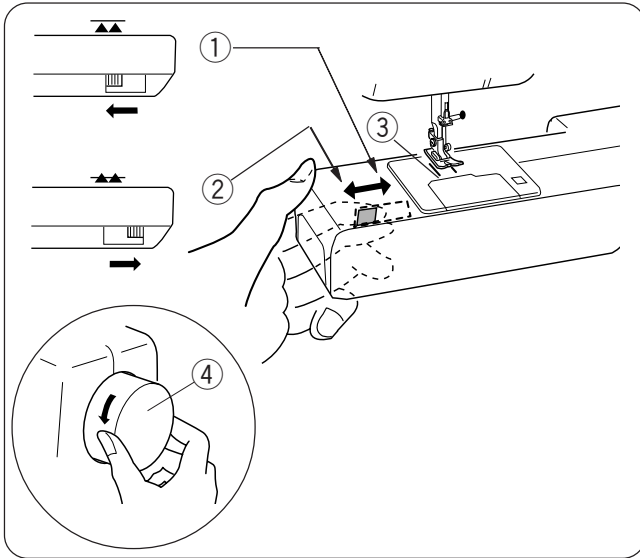

Dropping the Feed Dog

The feed dog can be lowered with the drop-feed lever for sewing on buttons etc.

Shift the drop-feed lever to the right to lower the feed dog.

Shift the lever to the left to raise the feed dog, it will return to the up position when the machine is started.

- ① Down position
- ② Up position
- ③ Feed dog
- ④ Hand wheel

NOTE:

The feed dog should be in the up position for regular sewing. Turn the handwheel toward you to check if the feed dog comes up after setting the lever in the up position.

Changing the Presser Foot

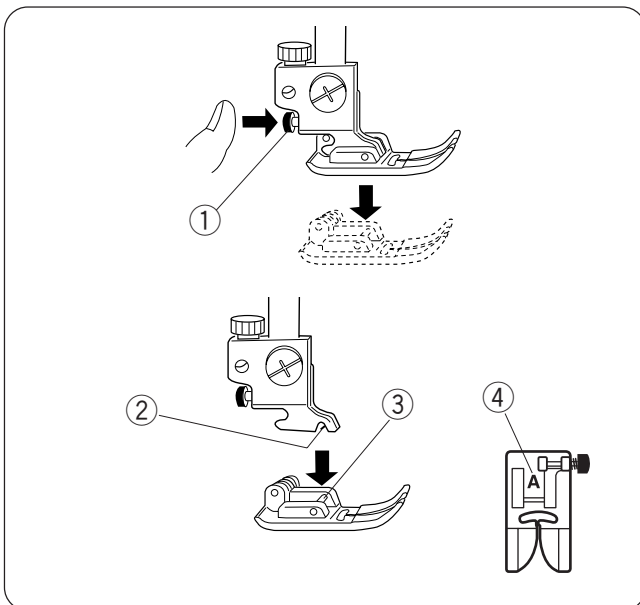

CAUTION:

Turn OFF the power switch before changing the foot. Always use the proper foot for the selected pattern. The wrong foot can cause the needle to break.

To snap off:

Raise the needle and presser foot. Press the red button on the back of the foot holder and the foot will drop.

- ① Red Button

To snap on:

Place the presser foot so the pin on the foot lies just under the groove of the foot holder. Lower the foot holder to lock the foot in place.

- ② Groove
- ③ Pin

Each foot is marked with a letter for identification.

- ④ Identification Letter

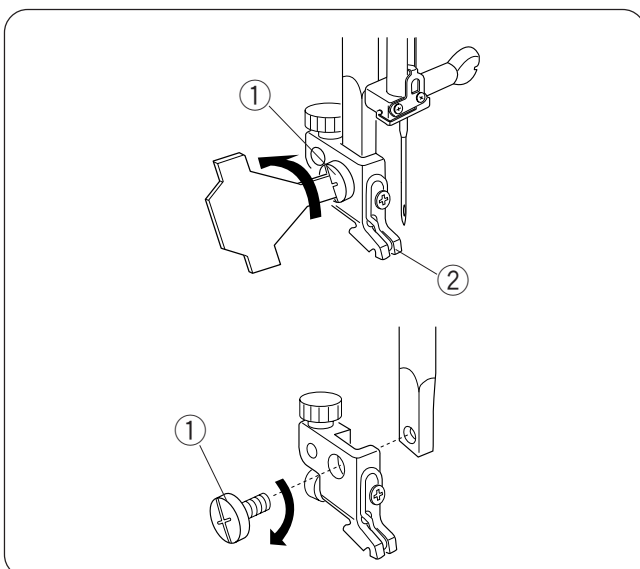

Detaching and Attaching the Foot Holder



WARNING:

Turn OFF the power switch before detaching or attaching the foot holder.

To detach:

Raise the presser bar and turn the setscrew counterclockwise to remove the foot holder.

- ① Setscrew
- ② Foot holder

To attach:

Align the hole in the foot holder with the threaded hole in the presser bar and insert the setscrew through the hole.

Tighten the setscrew by turning it clockwise.

Raising and Lowering the Presser Foot

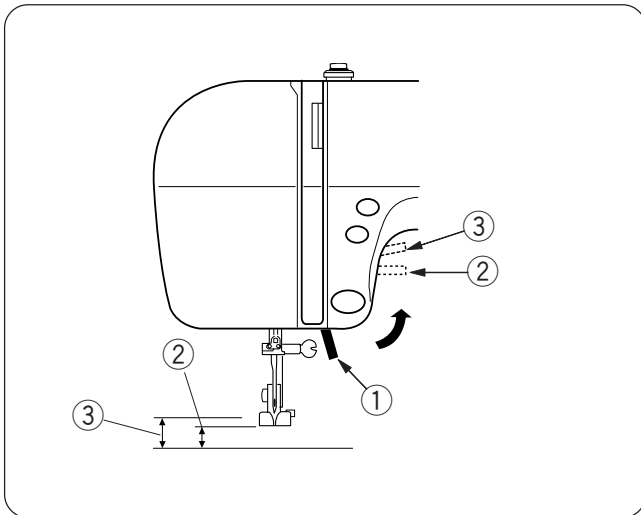

The Presser foot lifter raises and lowers the presser foot.

You can raise the presser foot about 6 mm (1/4") higher than the normal up position by exerting more pressure when lifting the presser foot lifter. This allows for easy removal of the presser foot and helps you to place thick fabric under the foot.

- ① Presser foot lifter
- ② Normal up position
- ③ Extra lift

Balancing Thread Tension

Auto tension

This machine features an **Auto** setting in the tension control, which covers a wide range of sewing conditions. Set the tension regulating dial at "A" for general sewing, unless specifically indicated in this manual.

- ① Tension regulating dial
- ② Setting mark

Balanced tension:

The ideal straight stitch has threads locked between two layers of fabric.

For an ideal zigzag stitch, the bobbin thread does not show on the right side of the fabric, and the needle thread shows slightly on the wrong side of the fabric.

- ③ Needle thread
- ④ Bobbin thread
- ⑤ Right side of the fabric
- ⑥ Wrong side of the fabric

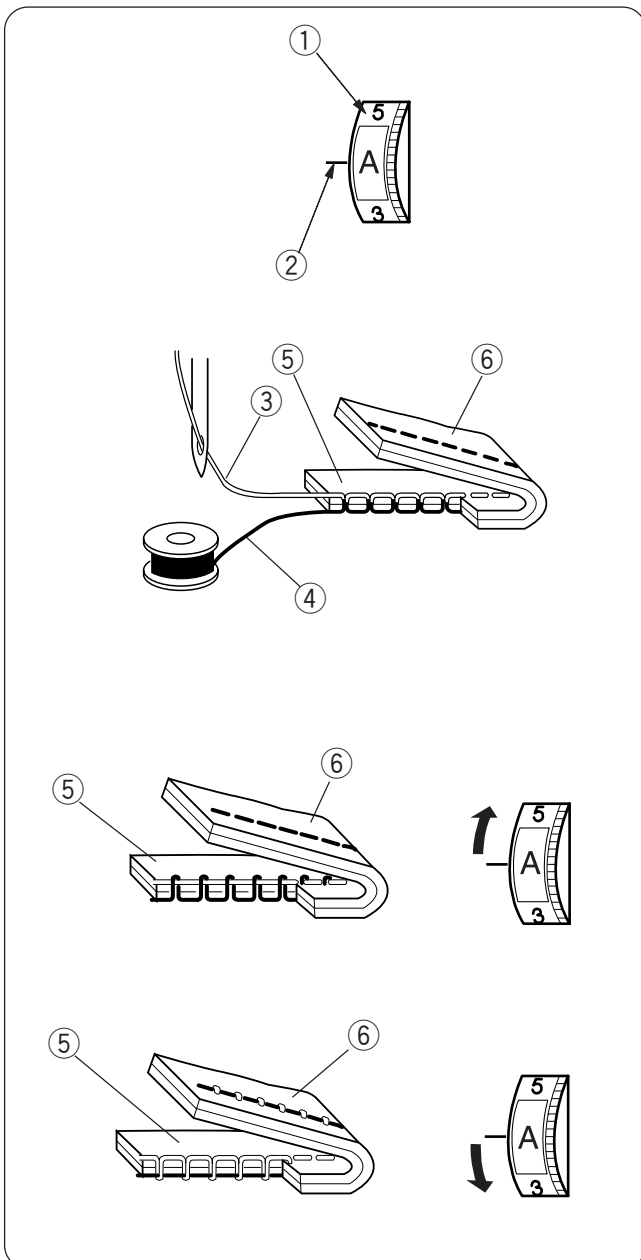

Manual tension adjustment

Manual tension adjustment may be needed depending on the sewing materials, layers of fabric and other sewing conditions.

Needle thread tension is too tight:

-if the bobbin thread appears on the right side of the fabric.

Loosen the needle thread tension by moving the dial to a lower number.

Needle thread tension is too loose:

-if the needle thread appears on the wrong side of the fabric.

Tighten the needle thread tension by moving the dial to a higher number.

Changing Needles

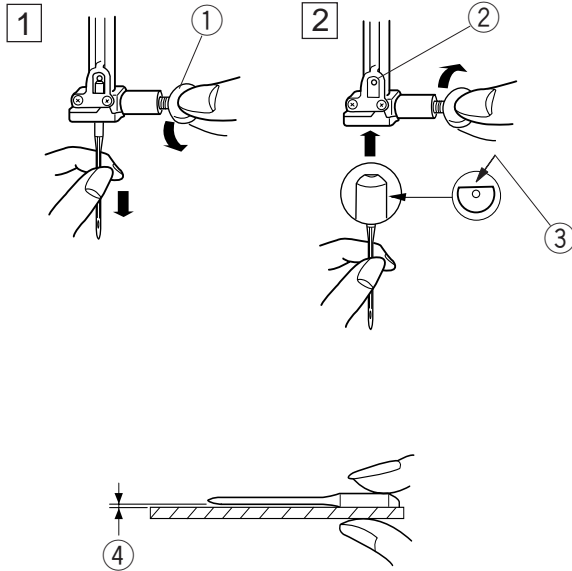
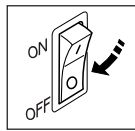

⚠ CAUTION:

Always make sure to turn the power switch off and disconnect the machine from power supply before changing the needle. Raise the needle by pressing the up/down needle button and lower the presser foot. Turn off the power switch.

- 1 Loosen the needle clamp screw by turning it counterclockwise.
Remove the needle from the clamp.
 - ① Needle clamp screw
- 2 Insert a new needle into the needle clamp with the flat side of the needle to the rear.
When inserting the needle into the needle clamp, push it up against the stopper pin and tighten the needle clamp screw firmly.
 - ② Stopper pin
 - ③ Flat side

To check needle straightness, place the flat side of the needle onto something flat (a needle plate, glass etc.) The gap between the needle and the flat surface should be consistent.
Never use a blunt needle.

- ④ Gap

WEIGHT	FABRIC	TYPE of NEEDLE	NEEDLE SIZE
Very Light	Chiffon, Georgette, Fine Lace, Organdy Net, Tulle	Universal Ball Point	9 (65) 9 (65)
Light	Batiste, Voile, Lawn, Pure Silk, Crepe de Chine, Sheer Crepe, Chambray, Handkerchief Linen, Gingham, Challis, Percale, Wool Crepe, Peau de Soie, Taffeta, Satin, Silk Surah, Satin-backed Crepe, Qiana	Blue Tipped Needle Universal	11 (75) 11 (75) 12 (80)
	Single Knits, Jersey, Swimwear, and Tricot	Blue Tipped Needle Ball Point	11 (75) 11 (75)
	Leather Suede	Wedge Point Leather Needle	11 (75)
Medium	Flannel, Velour, Velvet, Muslin, Velveteen, Poplin, Corduroy, Broadcloth, Linen, Chintz, Gabardine, Felt, Terry, Burlap, Quilted Fabrics	Universal	14 (90)
	Double Knits, (synthetic and natural) Stretch Velour, Stretch Terry, Sweater Knits	Ball Point	14 (90)
	Leather, Vinyl, Suede	Wedge Point Leather Needle	14 (90)
Heavy	Denim, Sailcloth, Ticking	Denim Needle	16 (100)
	Double Faced Wool, Heavy Coating, Fake Fur, Drapery Fabrics	Universal	16 (100)
	Leather, Suede	Wedge Point Leather Needle	16 (100) 18 (110)
Very Heavy	Canvas, Duck, Upholstery Fabrics	Universal	16 (100)
Topstitching for Special Finishes		Topstitching Needle	14 (90)

Winding the Bobbin

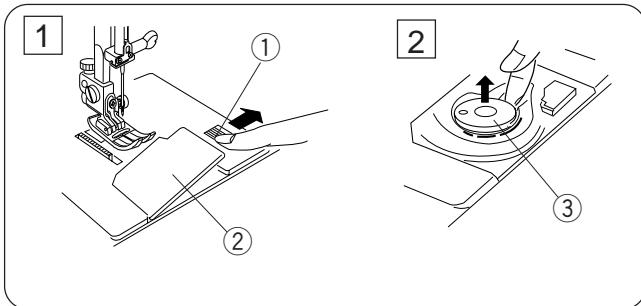

Removing the bobbin

- 1 Slide the hook cover plate release button to the right, and remove the hook cover plate.
 - 1 Hook cover plate release button
 - 2 Hook cover plate
- 2 Lift out the bobbin from the bobbin holder.
 - 3 Bobbin

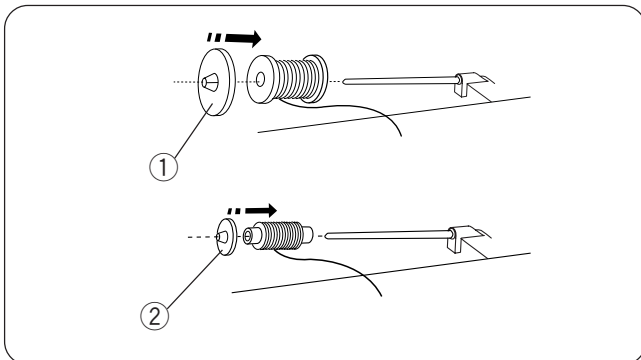

Setting the spool of thread

Lift up the spool pin. Place the spool of thread on the spool pin with the thread coming off the spool as shown.

- 1 Large spool holder

Attach the large spool holder, and press it firmly against the spool of thread.

Use the small spool holder to hold narrow or small spools of thread.

- 2 Small spool holder

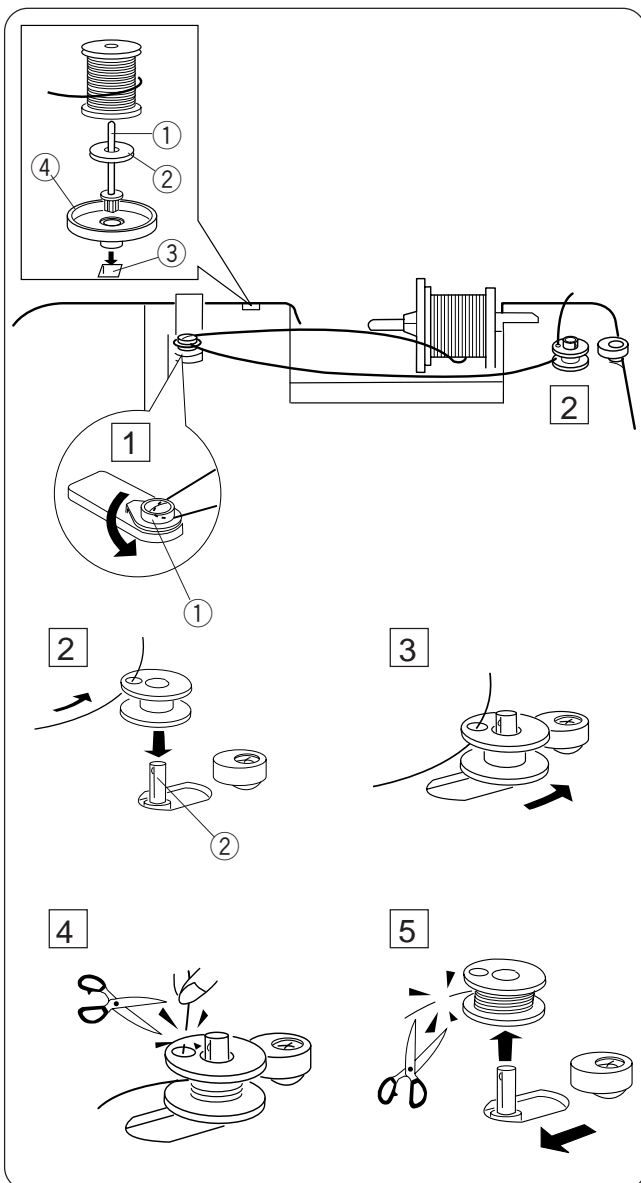

Additional spool pin

Use the additional spool pin when you need to wind the bobbin without unthreading the machine while working on a sewing project.

Insert the additional spool pin into the spool stand and then into the hole in the machine. Place the felt on the spool pin and place a spool of thread on it as shown.

- 1 Additional spool pin
- 2 Felt
- 3 Hole
- 4 Spool stand

Threading for bobbin winding

- 1 Set the speed control lever at **▶▶▶**. Guide the thread around the thread guide.
 - 1 Thread guide
- 2 Pass the thread through the hole in the bobbin from the inside to the outside. Put the bobbin on the bobbin winder spindle.
 - 2 Bobbin winder spindle
- 3 Push the bobbin winder spindle to the right. The indicator will show **SP**.
- 4 Hold the free end of the thread in your hand and depress the foot control. Stop the machine after the bobbin has spun several times, and cut the thread close to the hole in the bobbin.
- 5 Depress the foot control again. When the bobbin is fully wound, it will stop automatically. Release the foot control and return the bobbin winder spindle to its original position by moving it to the left, and cut the thread with a pair of scissors. Remove the bobbin from the bobbin winder spindle.

NOTE:

The machine will not sew until the spindle has been returned to the left.

Inserting the bobbin

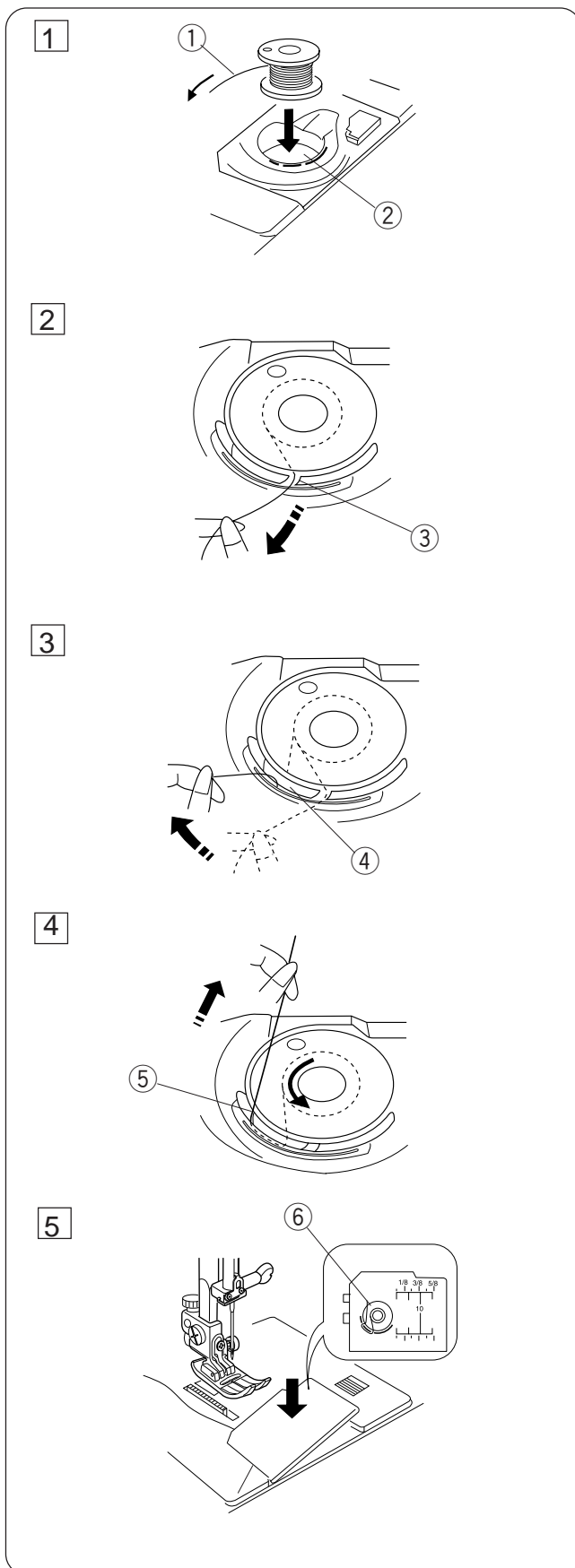

1 Place the bobbin in the bobbin holder with the thread running off counterclockwise.

- ① Thread
- ② Bobbin holder

2 Guide the thread into the notch on the front of the bobbin holder.

- ③ Notch on the front

3 Draw the thread to the left, sliding it between the tension spring blades.

- ④ Spring blades

4 Continue to draw the thread lightly until the thread slips into the notch on the side.

- ⑤ Notch on the side

5 Pull out about 10 cm (4") of thread to the rear. Reattach the hook cover plate.

NOTE:

A threading chart is shown on the hook cover plate for your reference.

- ⑥ Threading chart

Threading the Machine

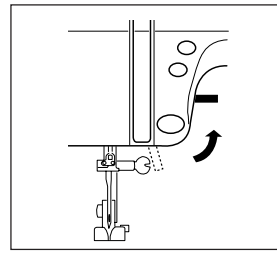
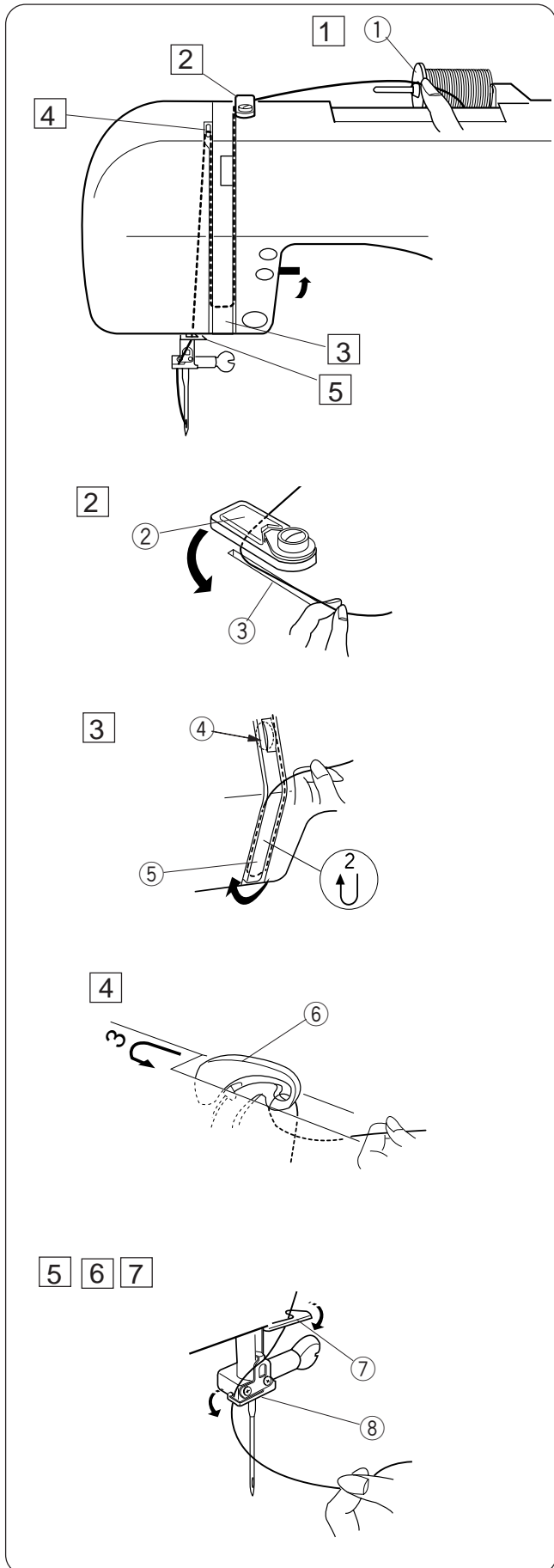

Raise the presser foot.
Press the Up/Down needle button to raise the thread take-up lever to its highest position.

- 1** Draw the thread from the spool. Hold the upper thread at the spool with your finger.

① Hold the thread

- 2** Slip the thread under the thread guide from the right and down along the right channel. Be sure that the thread passes between the tension disks.

② Thread guide

③ Right channel

④ Tension disks

- 3** Then draw the thread around the bottom of the thread guide plate.

⑤ Thread guide plate

- 4** Firmly draw the thread up along the left channel to the take-up lever and down into its eye from the right to the left.

⑥ Thread take-up lever

- 5** Then down through the lower thread guide.

⑦ Lower thread guide

- 6** Slide the thread behind the needle bar thread guide on the left.

⑧ Needle bar thread guide

- 7** Thread the needle from front to back by hand or use the built-in needle threader (see page 13).

Built-in Needle Threader

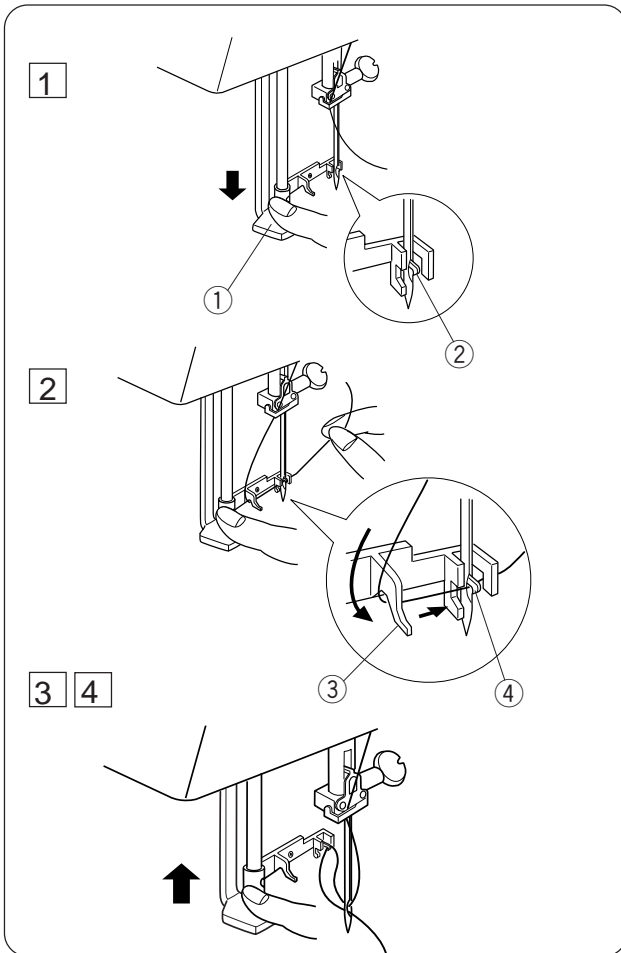

1 Raise the needle to its highest position by turning the hand wheel toward you.
Turn the power switch off.
Lower the presser foot.
Depress the needle threader knob as far as it will go. The hook comes out through the needle eye from behind.

- ① Needle threader knob
- ② Hook

2 Draw the thread down around the threader guide and under the hook.

- ③ Threader guide

3 Release the threader knob slowly while holding the thread end with your hand. A loop of the thread is pulled up through the needle eye.

4 Remove the loop from the threader and pull out the thread end from the needle eye.

NOTES:

The automatic threader works well with the threads #50-90 and needles #11-16, as well as the blue tipped needle.

Drawing Up the Bobbin Thread

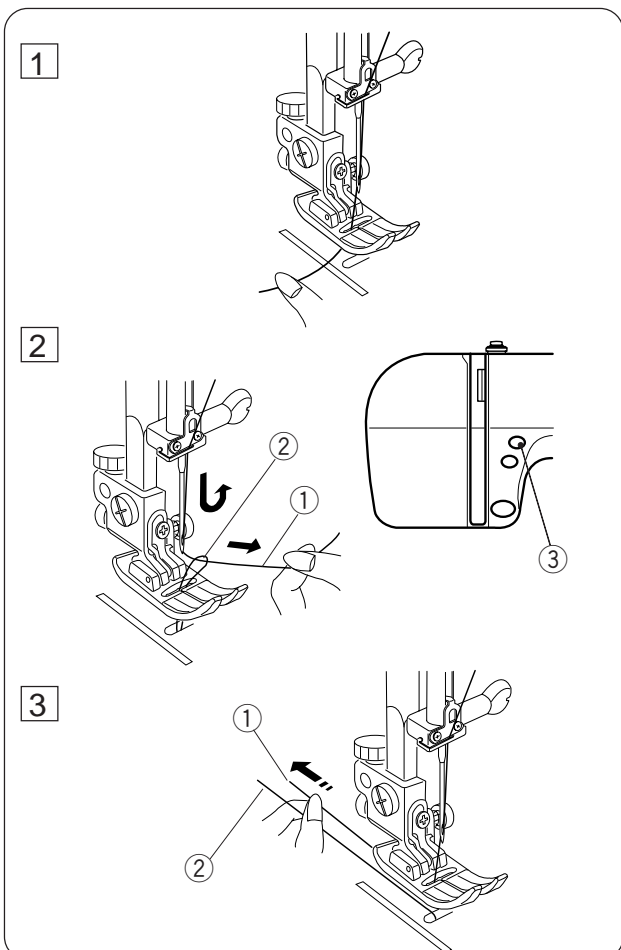

1 Raise the Presser Foot Lifter.
Turn the power switch on.

2 Hold the needle thread with your finger and press the Up/Down needle button twice to pick up the bobbin thread.
Draw up the needle thread to bring up a loop of the bobbin thread.

- ① Needle thread
- ② Bobbin thread
- ③ Up/Down needle button

3 Slide 10 cm (4") of both threads to the back under the presser foot.

BASIC STITCHES

Straight Stitch

Machine Settings

- ① Pattern: #01
- ② Presser foot: Zigzag foot A

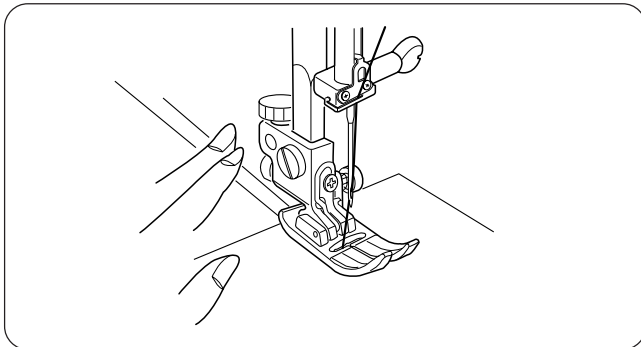
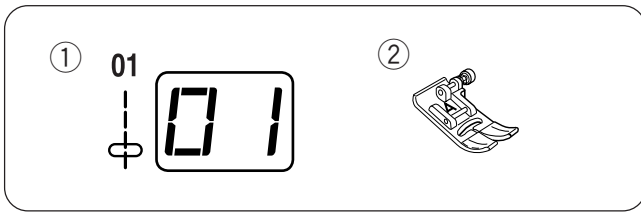

To sew

Raise the presser foot and position the fabric next to a seam guide line on the needle plate. Lower the needle into the fabric where you wish to start.

Pull the needle and bobbin threads to the back. Lower the presser foot.

Depress the foot control to start sewing. Gently guide the fabric along the seam guide line.

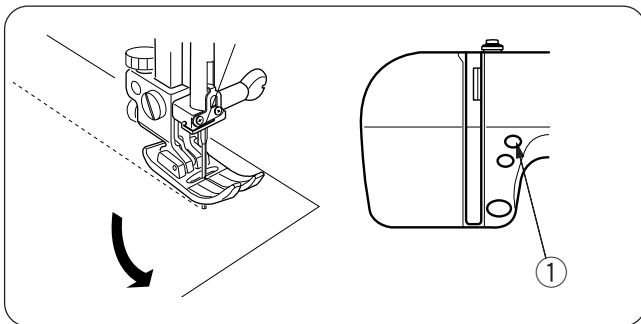

Changing sewing direction:

Stop the machine a few stitches before the end of a seam. Press the up/down needle button a few times until the needle falls on the end of the seam.

- ① Up/Down needle button

Raise the presser foot.

Pivot the fabric around the needle to change the sewing direction as desired.

Lower the presser foot and start sewing in a new direction.

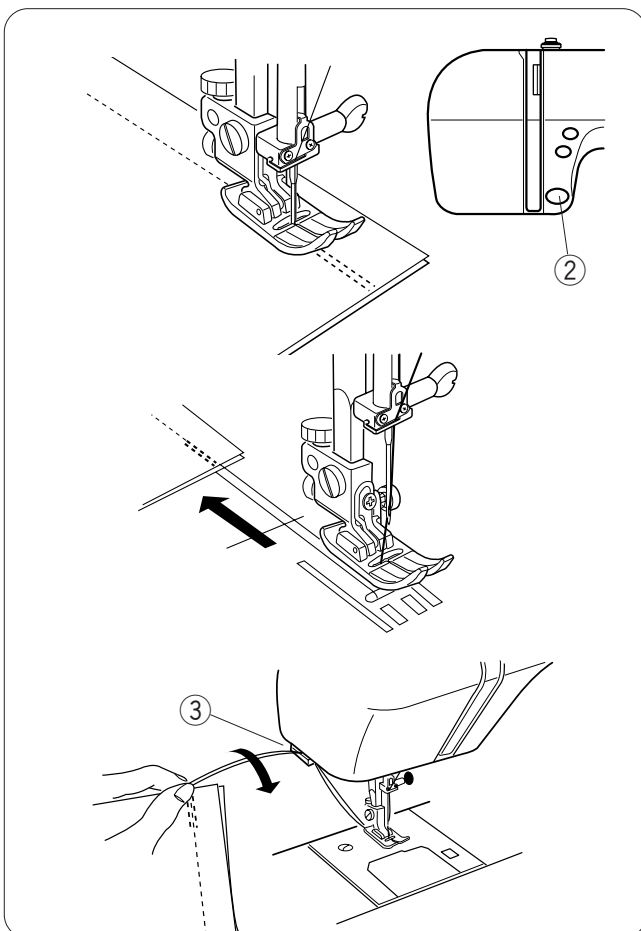

Securing a seam

For fastening the beginning of a seam, press the reverse button and sew several reverse stitches. Release the reverse button to sew forward.

- ② Reverse button

For fastening the ends of a seam, press the reverse button at the end of the seam.

Sew a few stitches in reverse to fasten the seam.

Raise the presser foot and pull the fabric to the back to remove it.

To cut the threads, pull the fabric to draw the threads up to the thread cutter as shown.

The threads are cut a proper length to start the next seam.

- ③ Thread cutter

When pattern #03 (lock-a-matic stitch)  is selected:

The machine will sew reverse stitches at the beginning of a seam automatically, and at the end of the seam by pressing the reverse button once.

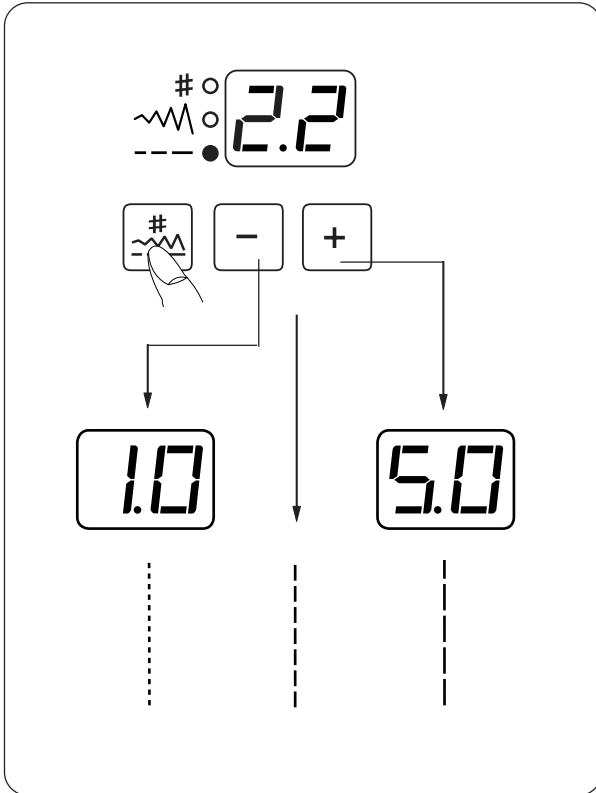

Altering the stitch length

The stitch length can be altered between 0.0 and 5.0.

Press the mode key  to activate stitch length adjustment (the bottom green light lights up). The preset value 2.2 will be indicated.

Press the plus (+) key to increase the stitch length.

Press the minus (-) key to decrease the stitch length.

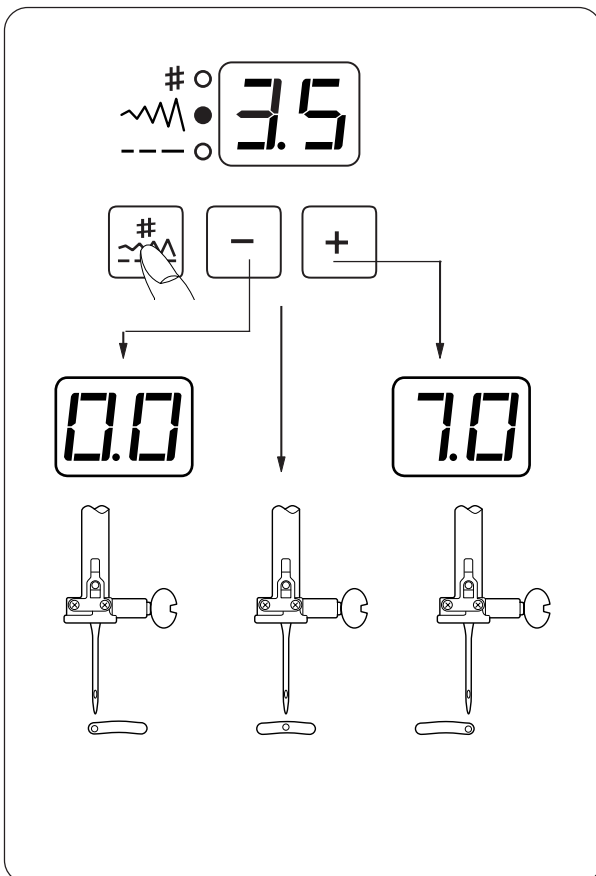

Altering the needle drop position

The needle drop position of the following stitches can be altered:

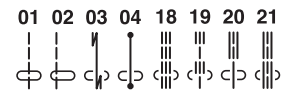

Press the mode key  to activate stitch width adjustment (the middle green light lights up). The preset value "3.5" will be indicated.

Press the plus (+) key to move the needle drop to the right.

Press the minus (-) key to move the needle drop to the left.

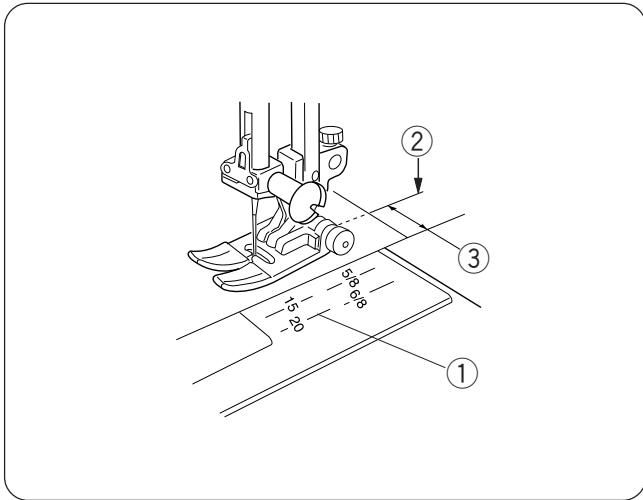

Using the seam guide lines

The seam guides on the needle plate and hook cover help you to measure seam allowances.

NOTE:

The number indicates the distance from the center needle position.

- ① Guide lines
- ② Center needle position
- ③ Edge of the fabric

Number	15	20	4/8	5/8	6/8
Distance (cm)	1.5	2.0	—	—	—
Distance (inch)	—	—	4/8	5/8	6/8

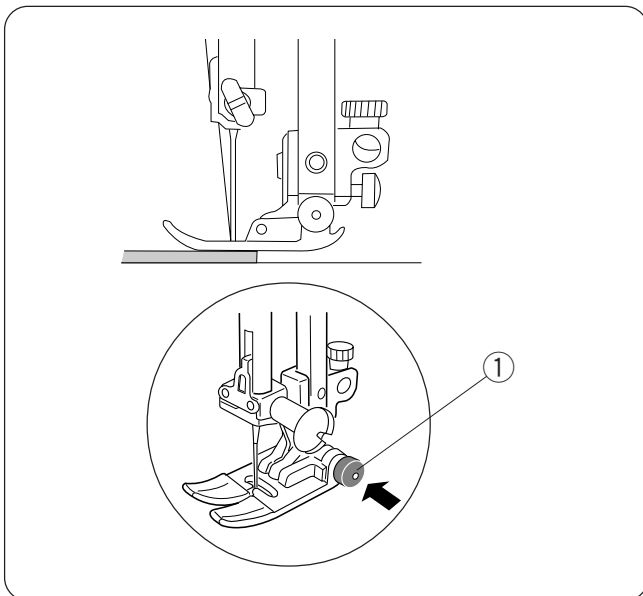

To sew from the edge of thick fabric:

The black button on the zigzag foot locks the foot in the horizontal position.

This is helpful when starting sewing from the extreme edge of thick fabrics or sewing across a hem.

Lower the needle into the fabric at the point where you wish to start sewing.

Lower the foot while pushing in the black button.

The foot will be locked in the horizontal position to avoid slipping.

The foot will be unlocked after sewing a few stitches.

- ① Black button

Variety of Straight Stitches and Recommended Feet

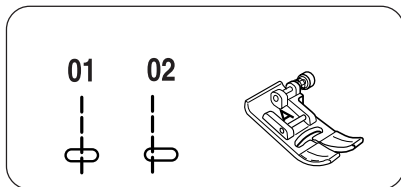

#01, #02 Straight stitch: Zigzag foot A

Pattern #01 is for seaming and for zipper sewing.

Pattern #02 is for seaming edge of fabrics.

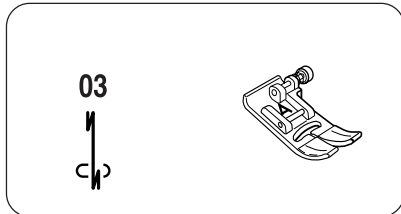

#03 Lock-a-matic stitch: Zigzag foot A

Use this stitch to secure the beginning and the end of a seam with backstitching.

When you reach the end of the seam, press the Reverse Button once. The machine will sew four reverse stitches, four forward stitches, and then stop sewing automatically.

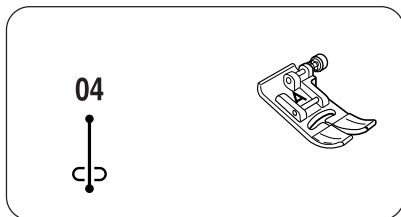

#04 Locking stitch: Zigzag foot A

This unique stitch is used where an invisible locking stitch is needed. Lower the needle close to the front edge of the fabric.

The machine will sew several locking stitches in place and continue sewing forward.

When you press the reverse button at the end of the seam, the machine will sew several locking stitches in place, then stop sewing automatically.

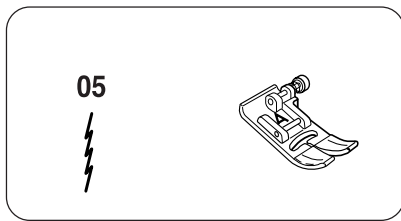

#05 Stretch stitch: Zigzag foot A

This is a narrow stretch stitch designed to eliminate puckering on knit fabrics and bias seams, while allowing the seam to be pressed completely open flat.

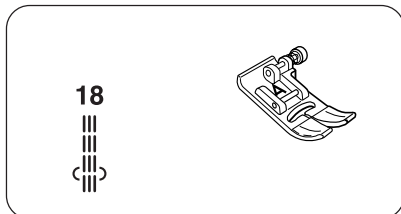

#18 Triple stretch stitch: Zigzag foot A

This strong, durable stitch is recommended for areas where both elasticity and strength are needed to ensure comfort and durability. Use it to reinforce areas such as crotch and armhole seams.

Also use it when constructing items such as backpacks for extra strength.

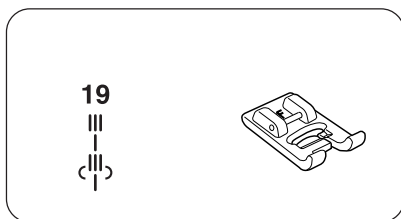

#19 New sculpture stitch: Satin stitch foot F

This stitch is used for topstitches and outline-stitches enhancing the design appearance.

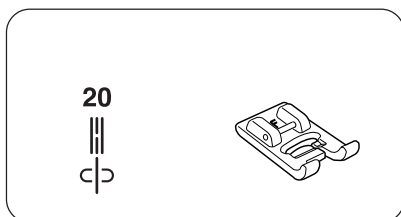

#20 Sculpture stitch: Satin stitch foot F

This stitch is used for topstitches and outline-stitches enhancing the design appearance.

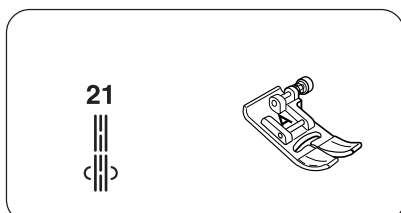

#21 Saddle stitch: Zigzag foot A

This saddle stitch is formed with one stitch forward, two stitches backward, and a fourth stitch forward.

You can achieve an attractive hand-worked look when topstitching suits, blazers, jumpsuits, and denim outfits with the saddle stitch.

Zigzag Stitch

Machine Settings

- ① Pattern: #10
- ② Presser foot: Zigzag foot A

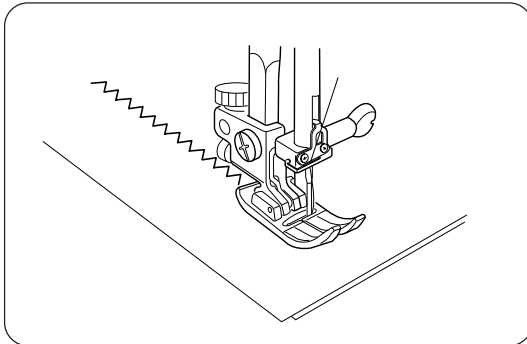
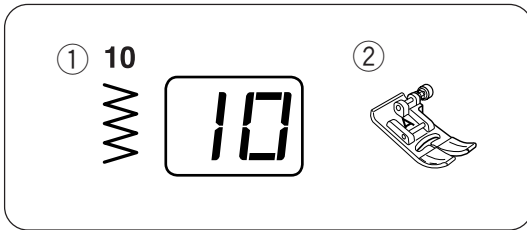

The zigzag stitch is used for various sewing needs including overcasting. It can be used on most woven fabrics.

A dense zigzag stitch can also be used for appliqué.

Altering the stitch width

The stitch width can be altered between 0.0 and 7.0.

Press the mode key  to activate stitch length adjustment (the middle green light lights up). The preset value "5.0" will be indicated.

Press the plus (+) key to increase the stitch width.

Press the minus (-) key to decrease the stitch width.

- ① Stitch width

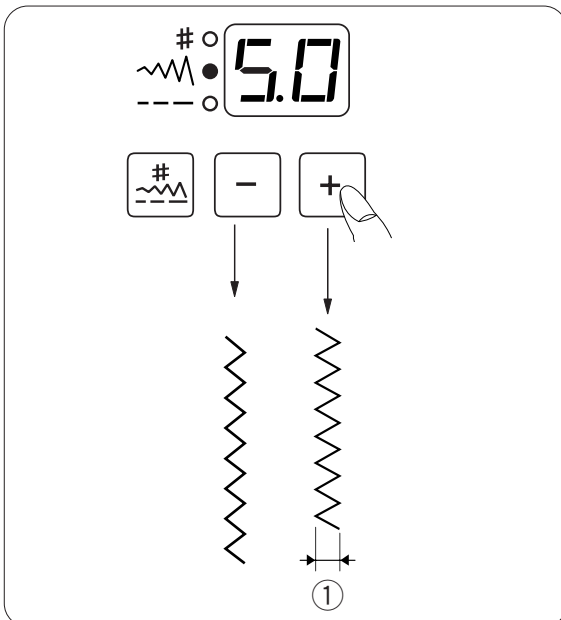

Altering the stitch length

The stitch length can be altered between 0.0 and 5.0.

Press the mode key  to activate stitch length adjustment (the bottom green light lights up). The preset value 2.0 will be indicated.

Press the plus (+) key to increase the stitch length.

Press the minus (-) key to decrease the stitch length.

- ② Stitch length

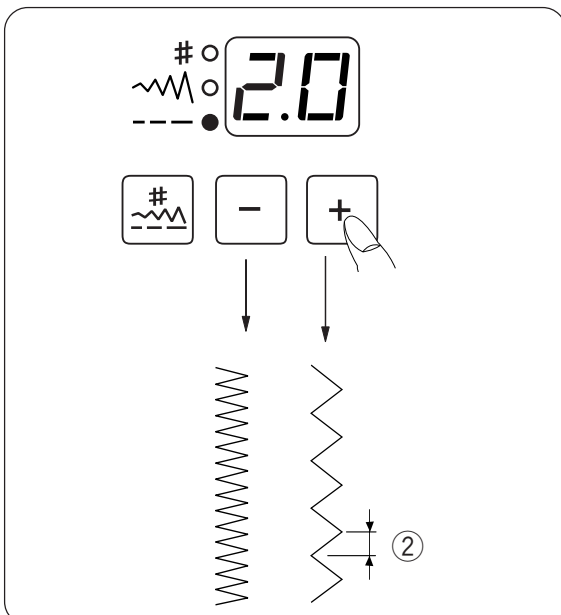

NOTE:

The stitch length and width can be altered while stitching.

Variety of Overcasting Stitches



CAUTION:

When you use the overedge foot C, you must set the zigzag width at 5.0 or wider to prevent the needle from hitting the wires on the foot.

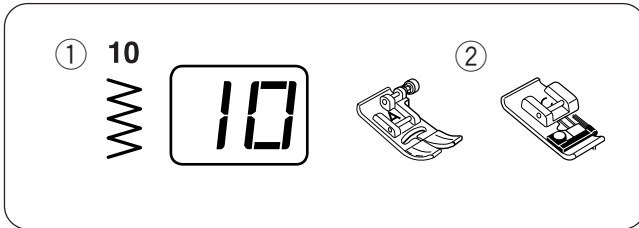

Overcasting with zigzag stitch

Machine Settings

- ① Pattern: #10
- ② Presser foot: Zigzag foot A or Overedge foot C (optional item)

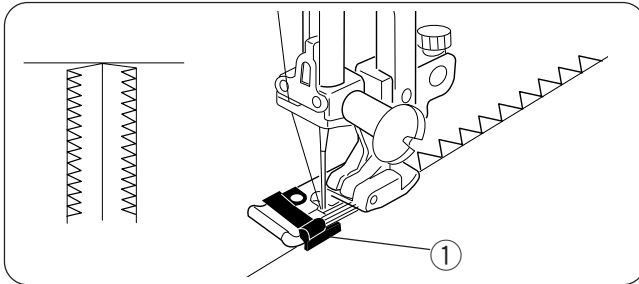

Place the fabric edge next to the guide of the foot and then sew.

- ① Guide

NOTES:

The overedge foot is an optional item. When overcasting with the zigzag foot, carefully guide the fabric so the needle falls off the edge when it swings to the right.

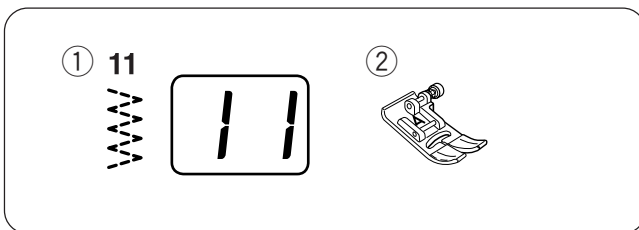

Multiple zigzag stitch (Tricot stitch)

Machine Settings

- ① Pattern: #11
- ② Presser foot: Zigzag foot A

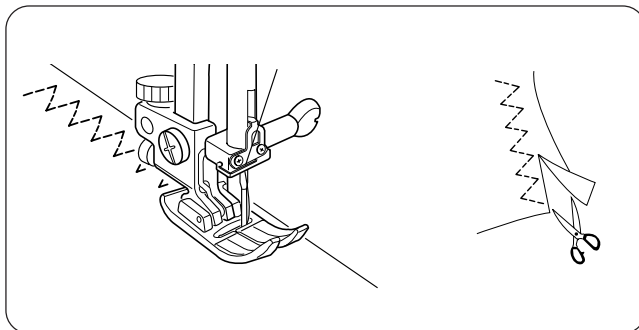

This stitch is used to finish a raw edge of synthetics and other stretch fabrics that tend to pucker. Sew along the fabric edge leaving an adequate seam allowance.

After sewing, trim the seam allowance close to the stitches.

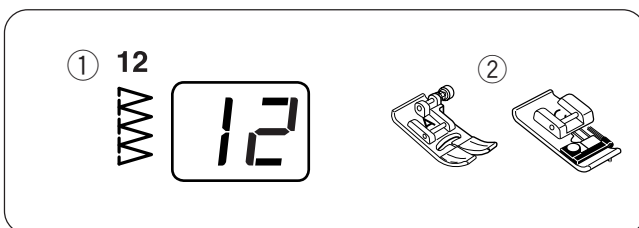

Overcasting stitch

Machine Settings

- ① Pattern: #12
- ② Presser foot: Zigzag foot A or Overedge foot C (optional item)

This stitch can be used to simultaneously seam and overcast edges of fabrics.

Use this stitch when you do not need to open seams flat. Place the fabric edge next to the guide of the foot and then sew.

- ① Guide

NOTES:

The overedge foot is an optional item. When overcasting with the zigzag foot, carefully guide the fabric so the needle falls off the edge when it swings to the right.

Double overedge stitch

Machine Settings

- ① Pattern: #14
- ② Presser foot: Zigzag foot A or Overedge foot C (optional item)

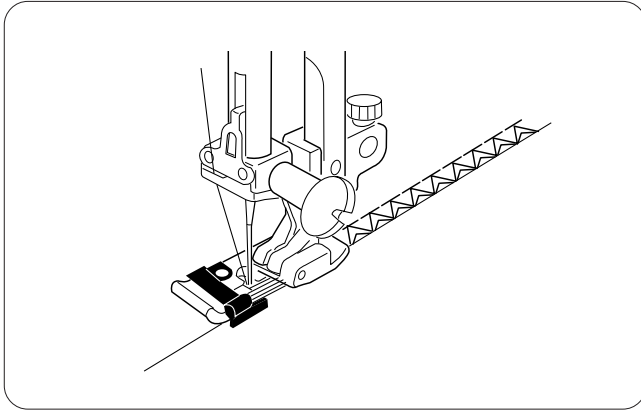
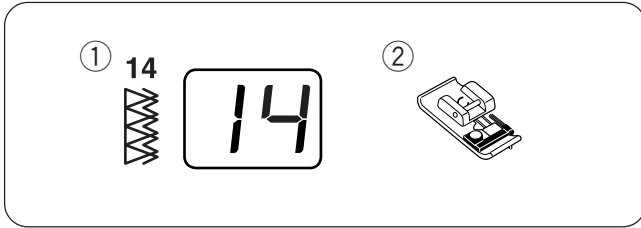

This is an excellent stitch for fabrics that tend to fray extensively such as linens and gabardines. Two rows of zigzag stitches are simultaneously sewn over the edge to insure that fabric will not ravel. Place the fabric edge next to the guide of the foot and then sew.

NOTES:

The overedge foot is an optional item. When overcasting with the zigzag foot, carefully guide the fabric so the needle falls off the edge when it swings to the right.



CAUTION:

When you use the overedge foot C, you must set the zigzag width at 5.0 or wider to prevent the needle from hitting the wires on the foot.

Buttonholes

Variety of buttonholes

#06 Square buttonhole

This square buttonhole is widely used on medium to heavy weight fabrics. The buttonhole size is automatically determined by placing a button in the rear of the foot.

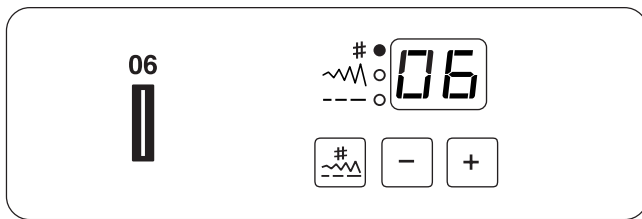

#07 Round-end buttonhole

This buttonhole is used on fine to medium weight fabrics especially for blouses and children's clothes.

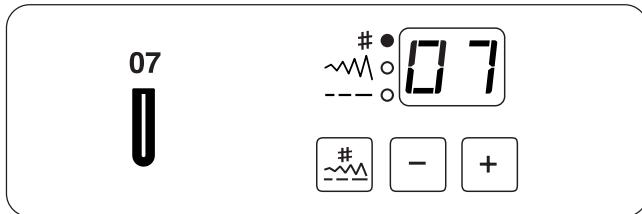

#08 Keyhole buttonhole

The Keyhole Buttonhole is widely used on medium to heavy weight fabrics. It is also suitable for larger and thicker buttons.

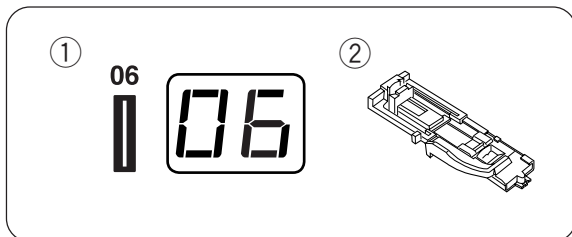
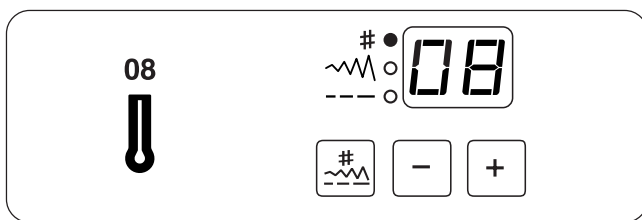

Square buttonhole

Machine Settings

- ① Pattern: #06
- ② Presser foot: Automatic buttonhole foot R

NOTES:

- The size of a buttonhole is automatically set by placing a button in the rear of automatic buttonhole foot R.
- The button holder of the foot takes a button size of 0.5 cm (3/16 ") to 2.5 cm (1") in diameter.
- It is sometimes necessary to change the buttonhole size to match certain heavy or specific fabrics and threads.
- Make a test buttonhole on an extra piece of the fabric to check your settings.
- The preset width of the buttonhole is suitable for ordinary buttons.
- Apply an interfacing to stretch or fine fabrics.

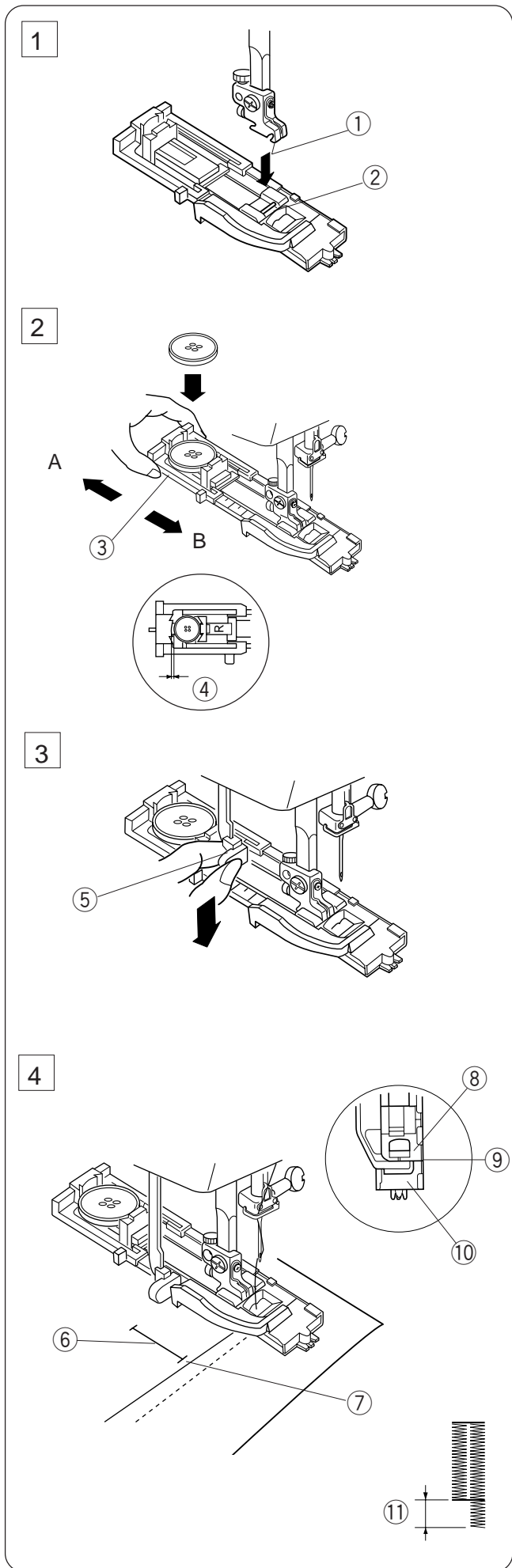

To sew

- 1 Press the up/down needle button to raise the needle.
Attach the automatic buttonhole foot R snapping the pin into the groove of the footholder.

- ① Groove
- ② Pin

- 2 Pull the button holder to the back, and place the button in it. Push it together tightly to the button.

NOTE:

If the button is extremely thick, make a test buttonhole on an extra piece of the fabric. If it is difficult to fit the button through the test buttonhole, you can lengthen the buttonhole by pulling the button holder back a little. The length of the buttonhole will be increased.

- ③ Button Holder
- ④ Extra gap

- 3 Pull the buttonhole lever down as far as it will go.

- ⑤ Buttonhole Lever

- 4 Insert the corner of the fabric under the foot. Press the up/down needle button twice. Remove the fabric to the left to draw the needle thread through the hole of the foot. Place the garment under the foot, and lower the needle at the starting point of the buttonhole mark.

Then lower the automatic buttonhole foot R.

- ⑥ Buttonhole Mark
- ⑦ Starting Point

NOTE:

Make sure there is no gap between the slider and stopper, otherwise the left and right lengths will be different.

- ⑧ Slider
- ⑨ No gap
- ⑩ Stopper
- ⑪ Sewing gap

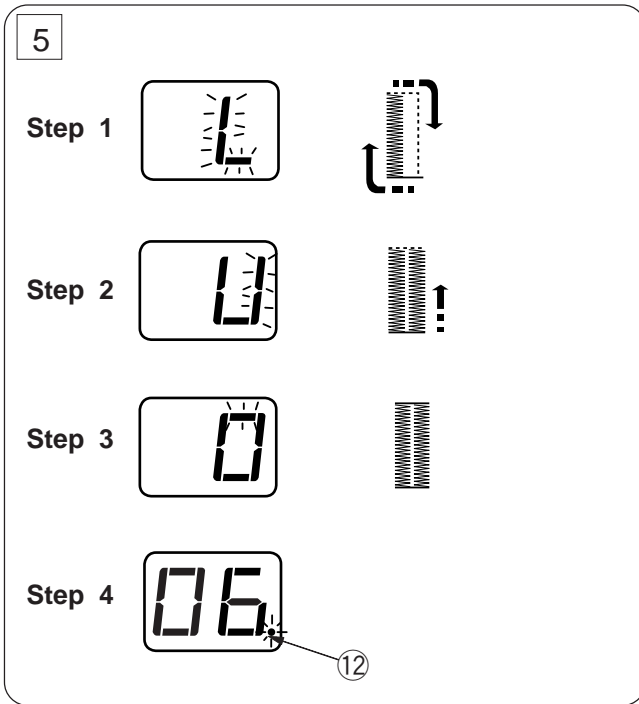

5 Start the machine to sew the buttonhole.
The buttonhole will be automatically sewn.

Step 1: The machine will sew the front bartack and the left row first.

Then it goes back to the starting point with straight stitch.

Step 2: The machine will sew the right row.

Step 3: The machine will sew the back bartack.

Step 4: The machine will stop automatically and a dot will blink.

⑫ Blinking dot

To sew another buttonhole, raise the presser foot. Move the fabric to where the next buttonhole is to be sewn, then lower the foot and start the machine.

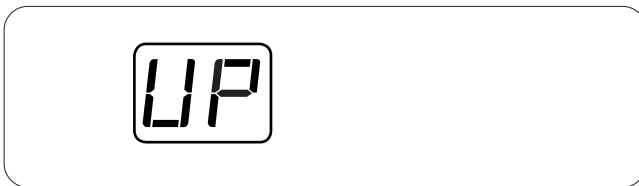

NOTE:

If you select other pattern without raising the presser foot or buttonhole lever after buttonhole sewing, the indicator will show a warning sign.

Raise the presser foot and buttonhole lever, then select the pattern.

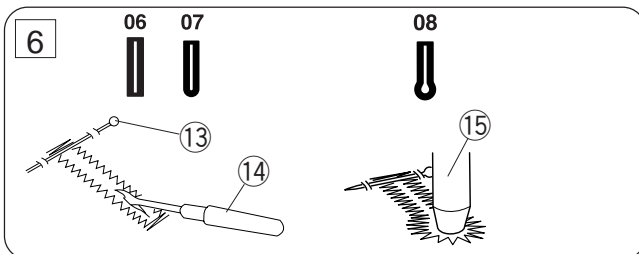

6 Remove the fabric and place a pin just below the bartack at each end to prevent accidentally cutting stitches. Cut the opening with the seam ripper. Use an eyelet punch to open a keyhole buttonhole.

⑬ Pin

⑭ Seam ripper

⑮ Eyelet punch

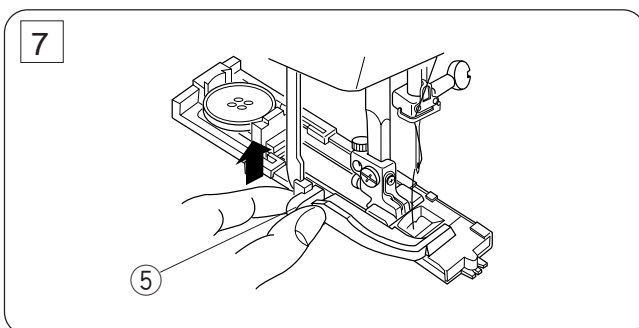

7 When buttonhole sewing is finished, push the buttonhole lever upward as far as it will go.

⑤ Buttonhole lever

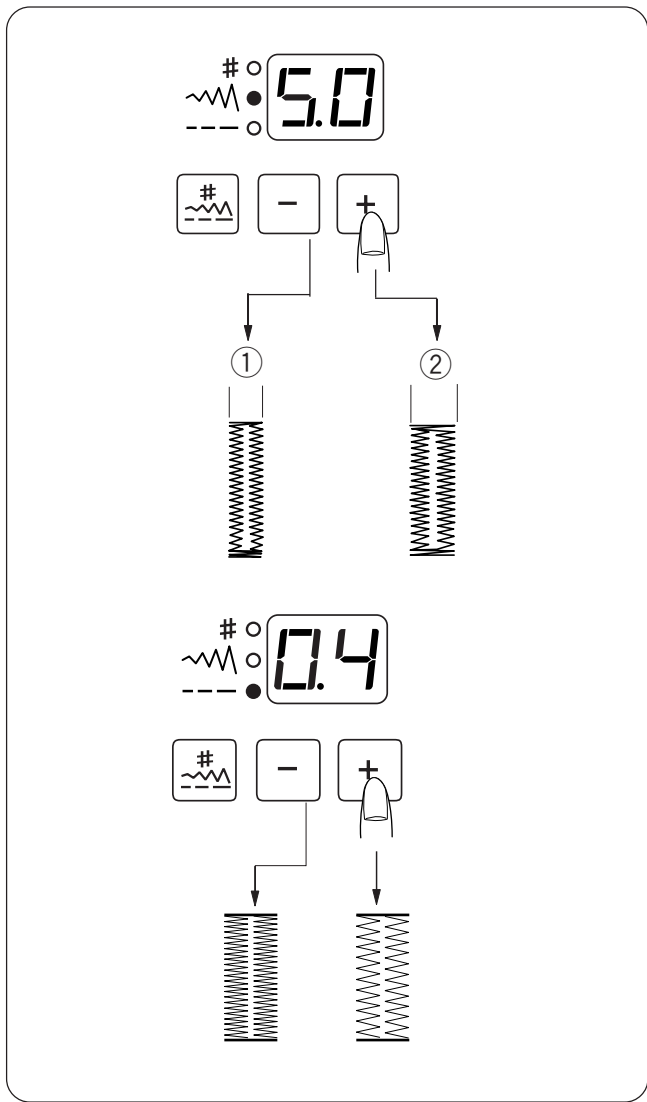

Altering the buttonhole width

Press the mode key to activate the stitch width adjustment.

Press the plus (+) key to increase the buttonhole width.

Press the minus (-) key to decrease the buttonhole width.

- ① Narrower buttonhole
- ② Wider buttonhole

* The width can be altered between 2.5 and 7.0.

Altering the buttonhole stitch density

Press the mode key to activate the stitch length adjustment.

Press the plus (+) key to make the stitch sparser.

Press the minus (-) key to make the stitch denser.

* The stitch density can be altered between 0.2 and 0.8.

NOTE:

The indicator shows the stitch width or density while sewing. When the buttonhole is completed, the indicator will show the pattern number .

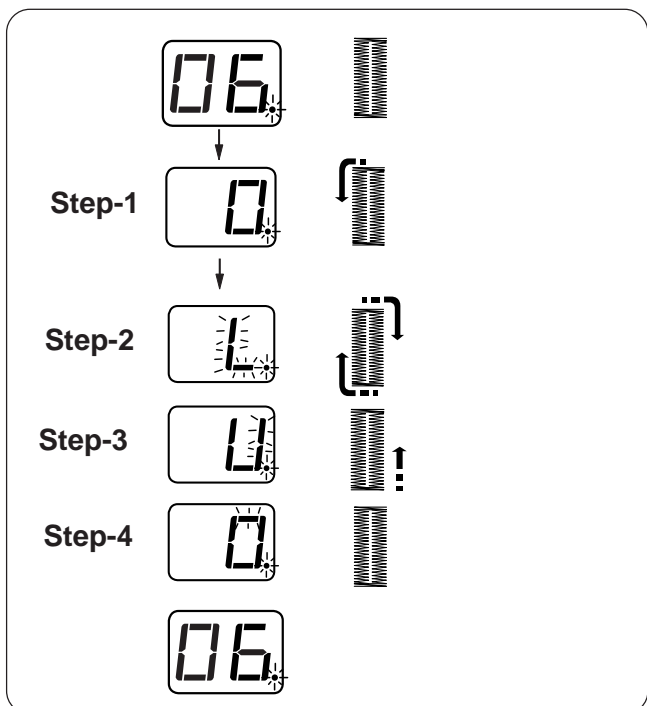

Double layer buttonhole

To make a solid and sturdy buttonhole, sew another layer of buttonhole over the previous stitches.

After the buttonhole is finished, simply start the machine again.

Do not raise the foot or buttonhole lever.

The machine will sew another buttonhole in the following order and stop automatically when it is completed:

Step 1: Straight stitching in reverse to go back to the starting point

Step 2: Front bartack and left row

Step 3: Right row

Step 4: Back bartack and locking stitches at the end
The machine will stop automatically.

NOTE:

A double layer buttonhole can be sewn when the dot is blinking.

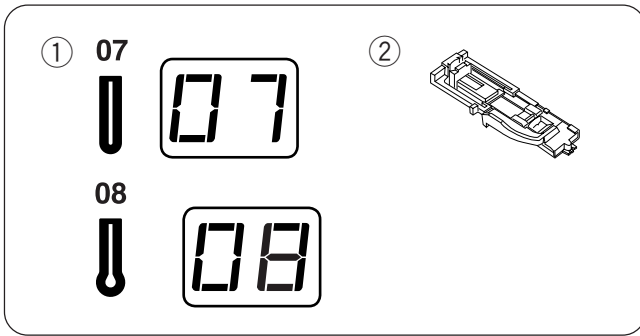

Round end and keyhole buttonholes

Machine Settings

- ① Stitch pattern: #07 or #08
- ② Foot: Automatic buttonhole foot R

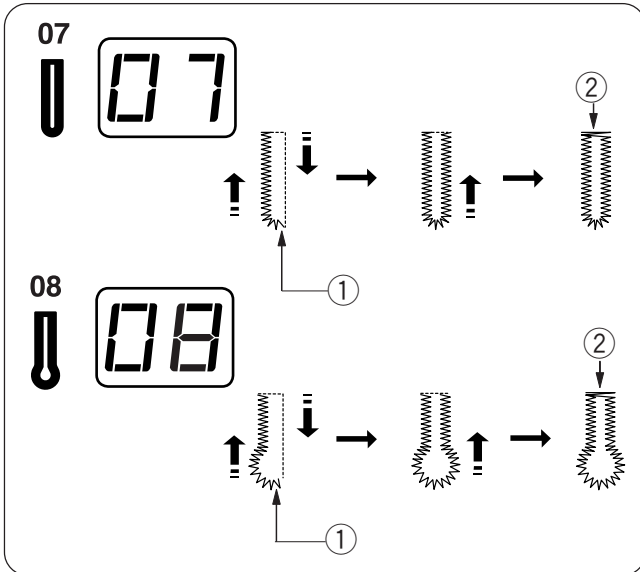

The sewing procedure is the same as the square buttonhole #06.

- ① Starting point
- ② Bartacking

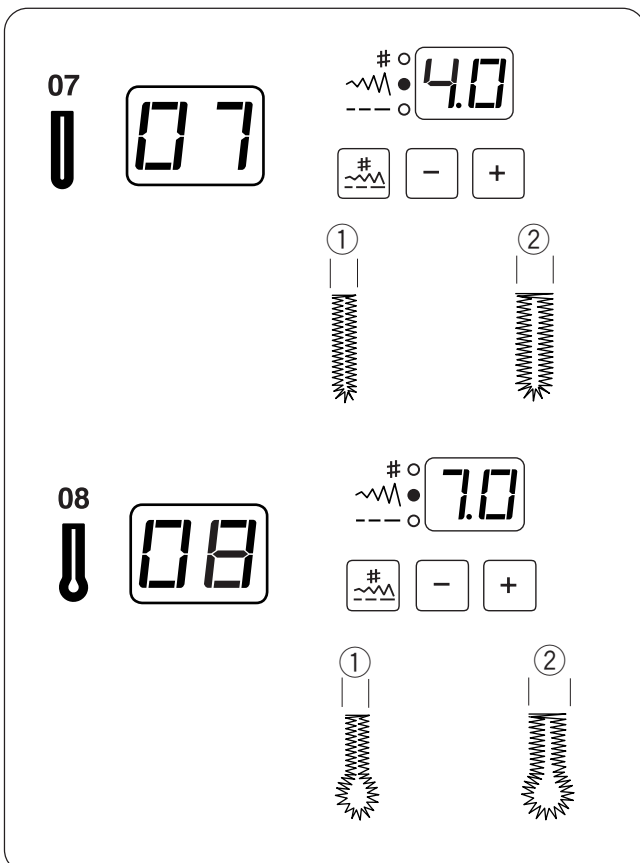

Altering the buttonhole width

Round-end buttonhole

Press the mode key  to activate the stitch width adjustment.

Press the plus (+) key to increase the buttonhole width.

Press the minus (-) key to decrease the buttonhole width.

- ① Narrower buttonhole
- ② Wider buttonhole

* The width can be altered between 2.5 and 5.5.

Keyhole buttonhole

Press the mode key  to activate the stitch width adjustment.

Press the plus (+) key to increase the buttonhole width.

Press the minus (-) key to decrease the buttonhole width.

- ① Narrower buttonhole
- ② Wider buttonhole

* The width can be altered between 5.0 and 7.0.

* See page 24 for altering the stitch density.

Corded buttonhole

Machine Settings

- ① Pattern: #06
- ② Presser foot: Automatic buttonhole foot R

To sew a corded buttonhole, follow the same procedure as for a square buttonhole.

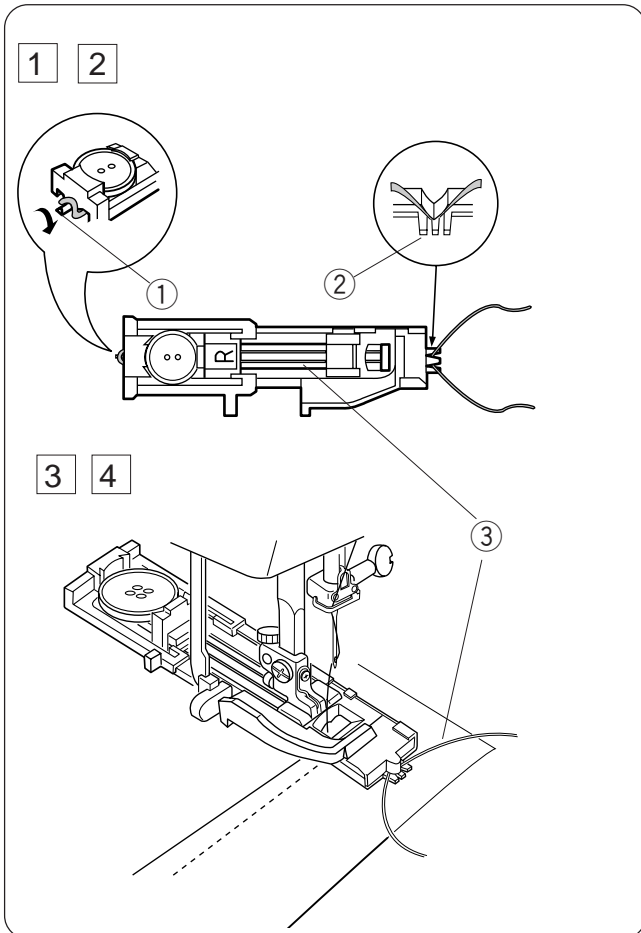
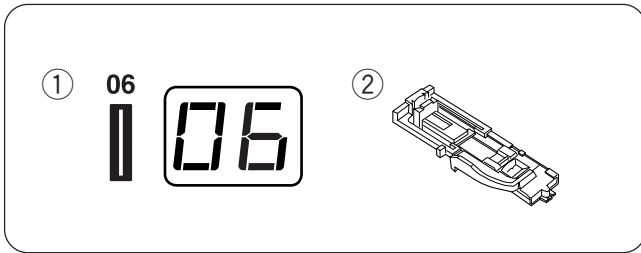

- 1 With the automatic buttonhole foot R raised, hook the filler cord on the spur on the back of the buttonhole foot.

- 2 Bring the ends of cord toward you under the buttonhole foot clearing the front end. Hook the ends of the filler cord into the forks on the front of the buttonhole foot to hold them tight.

- ① Spur
- ② Forks
- ③ Cord

- 3 Lower the needle into the garment where the buttonhole will start and lower the foot.

- 4 Lower the buttonhole lever and buttonhole foot. Start the machine and sew the buttonhole over the filler cord. The machine stops automatically when finished.

NOTES:

Set the stitch width in accordance with the thickness of the filler cord used.

To cut the buttonhole opening, refer to page 23.

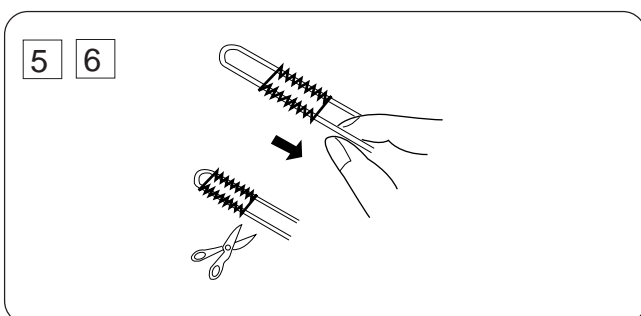

- 5 Remove the fabric from the machine and cut the sewing threads.

- 6 Pull the left end of the filler cord to tighten it. Thread the end of the cord through a darning needle and draw it to the wrong side of the fabric and cut.

Button Sewing

Machine Settings

- ① Pattern: #10
- ② Presser foot: Satin stitch foot F
- ③ Feed dog: Down

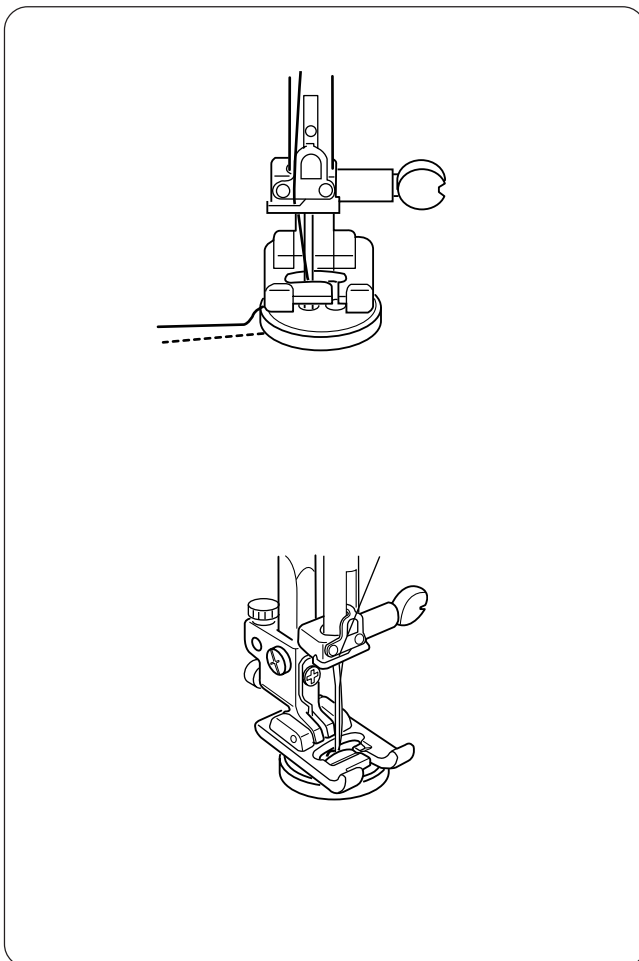
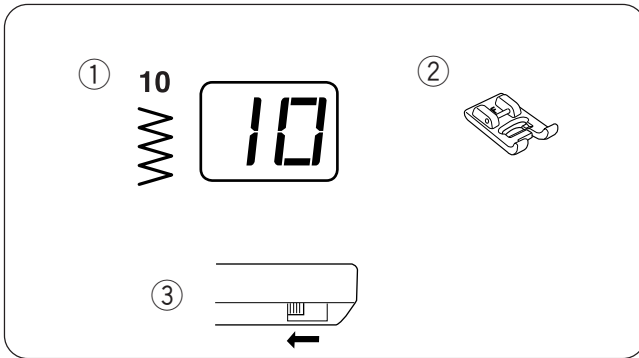

Unthread the needle thread.

Adjust the stitch width so that the needle enters both holes in the button.

Place a button on the fabric and lower the needle by turning the handwheel, so that the needle enters into the left hole in the button.

Align the holes in the button with the slot on the foot and lower it to hold the button in place.

Turn the handwheel to lower the needle into the right hole in the button.

Adjust the stitch width if necessary.

Rethread the machine and sew about 10 stitches at a slow speed (set the speed control slider at ►).

Raise the presser foot and remove the fabric.

Trim both needle and bobbin threads at the beginning.

Cut both threads leaving 20 cm (8") tails.

Pull the bobbin thread to bring the needle thread to the wrong side of the fabric then knot the threads.

After sewing is finished, raise the feed dog.

Darning

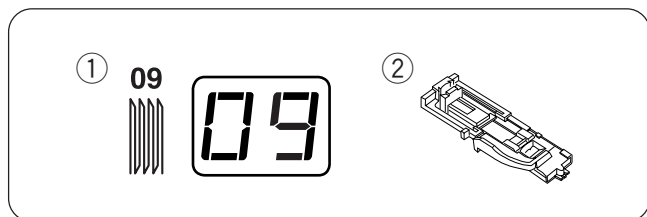

Machine Settings

- ① Pattern: #09
- ② Presser foot: Automatic buttonhole foot R

Pull the button holder to the rear.

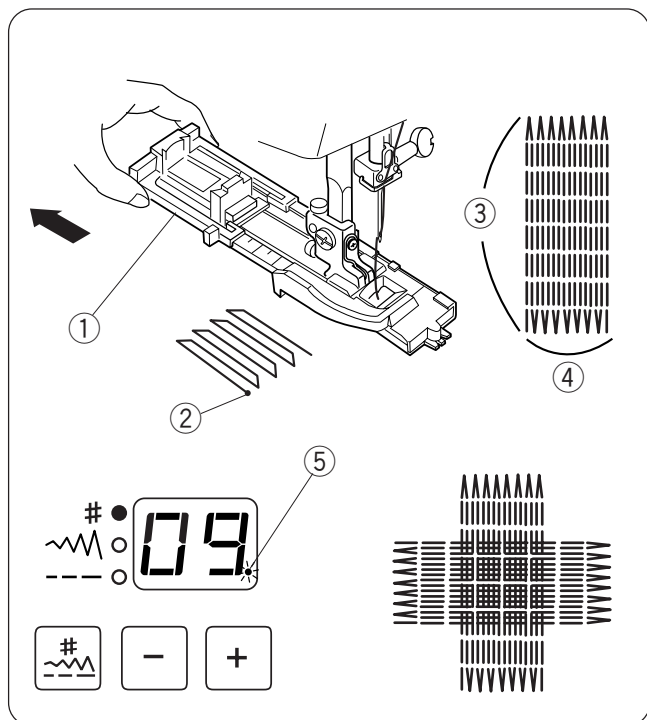

Place the fabric under the foot.

Press the up/down needle button twice. Pull the fabric from the left to draw both threads under the foot and place the fabric back under the foot.

Lower the needle at the starting point then lower the foot.

- ① Button Holder
- ② Starting Point

Depress the foot control and the machine will sew a darning 2 cm (3/4") long and stop automatically.

- ③ Darning length (Maximum: 2 cm)
- ④ Darning width (0.7 cm)

The same sized darning can be sewn when the dot is blinking.

- ⑤ Blinking dot

Repeat sewing in a different direction until the darning covers the rip or hole.

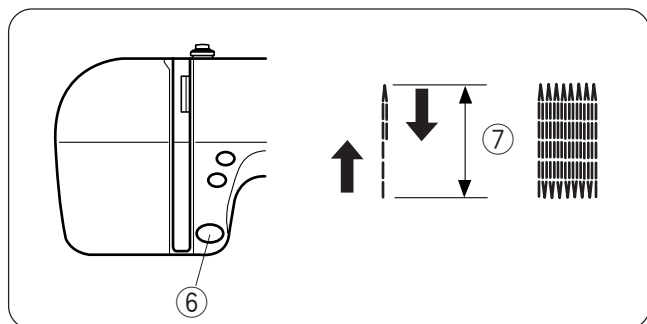

To sew a shorter darning

To sew a darning shorter than 2 cm (3/4"), first stop the machine after sewing the required length, then press the reverse button.

The required length has been determined.

Restart the machine and continue sewing until the machine stops automatically.

- ⑥ Reverse Button
- ⑦ Required Length

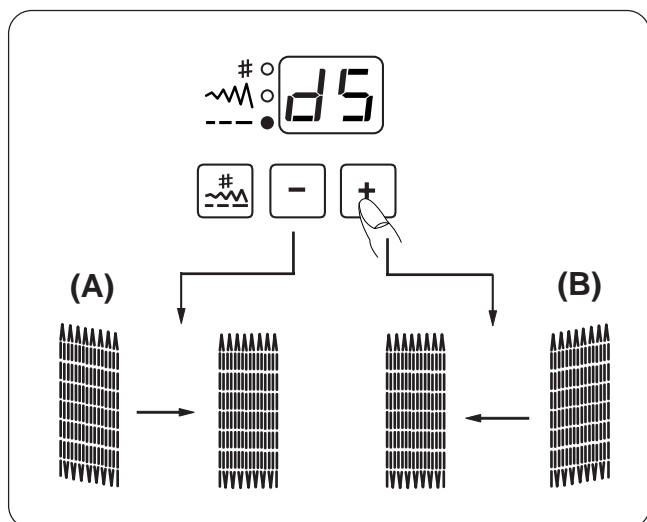

To adjust the evenness of darning

The evenness of darning may vary depending on the sewing conditions, such as type of fabrics, number of layers etc.

(A): If the left corner is lower than the right side, press the minus (-) key to correct it.

(B): If the right corner is lower than the left side, press the plus (+) key to correct it.

NOTE:

The evenness can be adjusted within d1 to d9 (default setting is d5).

Zipper Sewing

Machine Settings

- ① Pattern: #01
- ② Presser foot: Zipper foot E

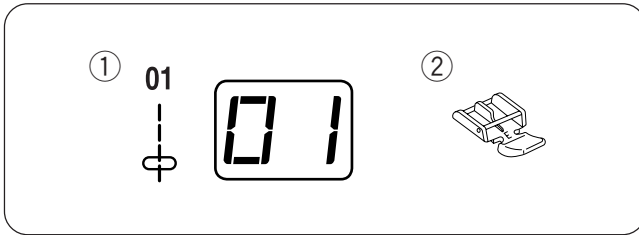

CAUTION:

When sewing with the zipper foot, make sure to use pattern "01 (straight stitch with the center needle position). Otherwise the needle may hit the foot and possibly break.

Attaching the zipper foot

- (A) Attach zipper foot E with the pin on the right-hand side to the groove to sew the left side of the zipper.
- (B) Attach zipper foot E with the pin on the left-hand side to the groove to sew the right side of the zipper.

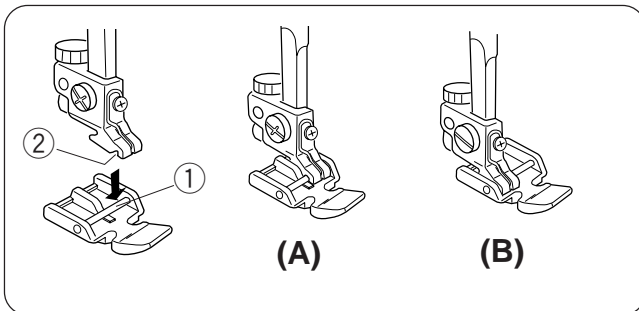

- ① Pin
- ② Groove

Fabric preparation for zipper sewing

- 1 Add 1 cm (3/8") to the zipper size. This is the overall opening size.

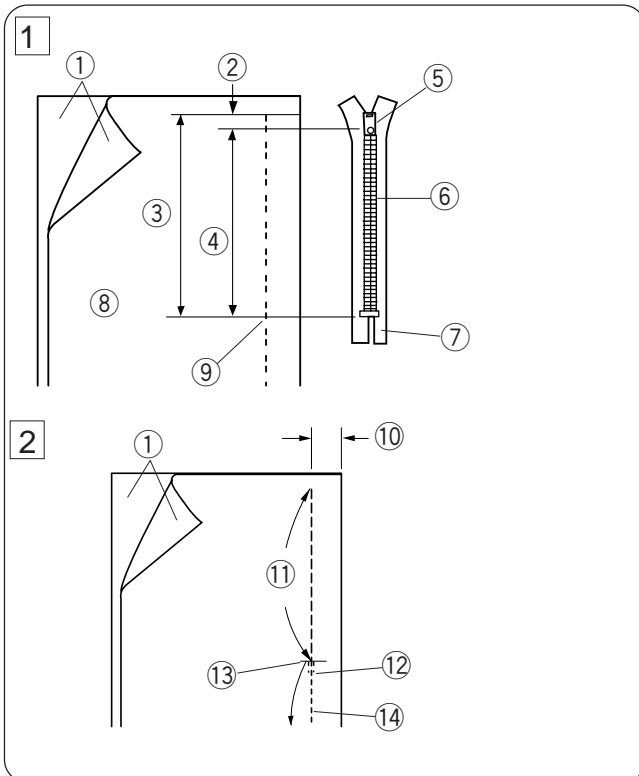

- ① Right side of the fabric
- ② 1 cm (3/8")
- ③ Opening size
- ④ Zipper size
- ⑤ Slider
- ⑥ Zipper teeth
- ⑦ Zipper tape
- ⑧ Wrong side of the fabric
- ⑨ End of the opening

- 2 Place the right sides of the fabric together and sew to the end of the zipper opening. Fasten the seam with reverse stitching. Increase the stitch length manually to 5 mm (3/16") and loosen the tension to "1" to sew the zipper opening with basting stitches.

- ⑩ 2 cm (13/16") seam allowance
- ⑪ Basting stitches
- ⑫ Reverse stitches
- ⑬ End of opening
- ⑭ Seam line

To sew

- 1 Fold back the left seam allowance. Turn under the right seam allowance to form a 0.2 to 0.3 cm (1/8") fold. Place the zipper teeth next to the fold and pin it in place.

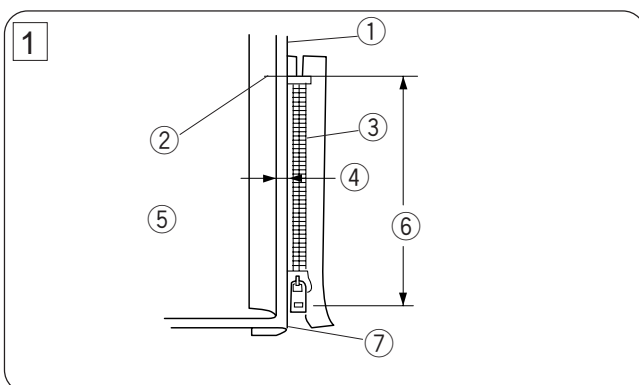

- ① Lower fabric
- ② End of the zipper opening
- ③ Zipper teeth
- ④ 0.2 to 0.3 cm (1/8")
- ⑤ Wrong side of the upper fabric
- ⑥ Opening size
- ⑦ Fold

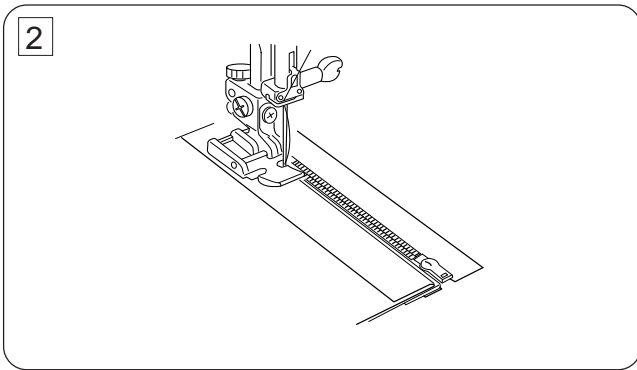

- 2 Set the stitch length back to "2.2" and thread tension to "A". Attach zipper foot E with the pin on the right-hand side. Sew through the fold and zipper tape guiding the zipper teeth along the edge of the foot.

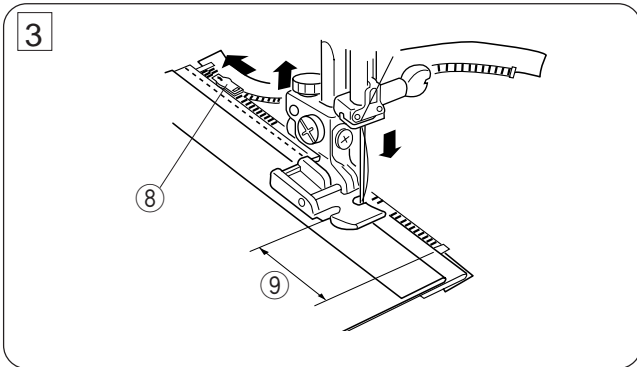

- 3 Stop sewing 5 cm (2") before the foot reaches the slider on the zipper tape. Lower the needle slightly into the fabric. Raise the foot and open the zipper. Lower the foot and stitch the remainder of the seam.

- 8 Slider
- 9 5 cm (2")

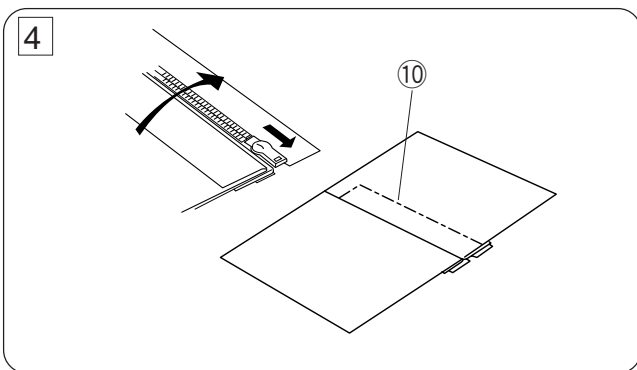

- 4 Close the zipper and spread the fabric open flat with the right side up. Baste the upper fabric and zipper tape together.

- 10 Basting

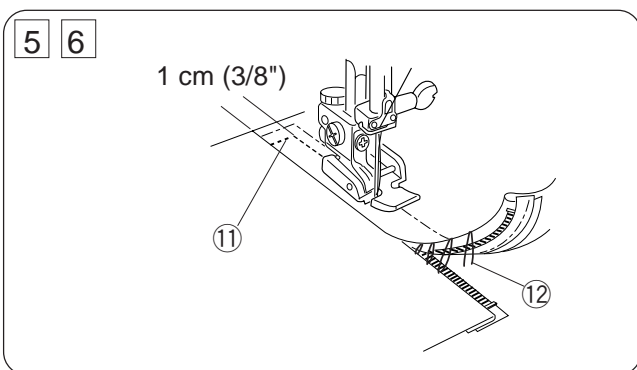

- 5 Reattach zipper foot E with the left pin. Sew 1 cm (3/8") across the end of the opening with reverse stitches. Stitch through the fabric and zipper tape.

- 11 End of the opening

- 6 Stop sewing about 5 cm (2") from the top of the zipper. Lower the needle slightly into the fabric, raise the foot, remove the basting stitches and open the zipper.

- 12 Basting Stitches

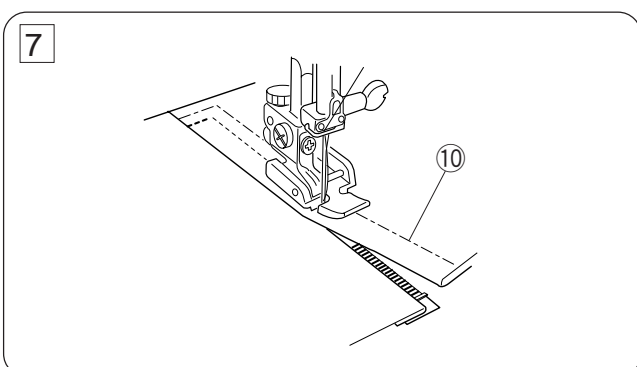

- 7 Move the slider behind the presser foot. Lower the presser foot and stitch the remainder of the seam. After finishing, remove the basting stitches.

- 10 Basting stitches

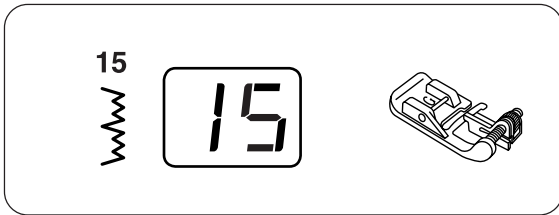

Blind Hem

Machine settings

- ① Stitch pattern: #15 or #16 }¹⁶
- ② Foot: Blind hem foot G (optional item)

NOTE:

The blind hem foot is an optional item.

Starting to sew

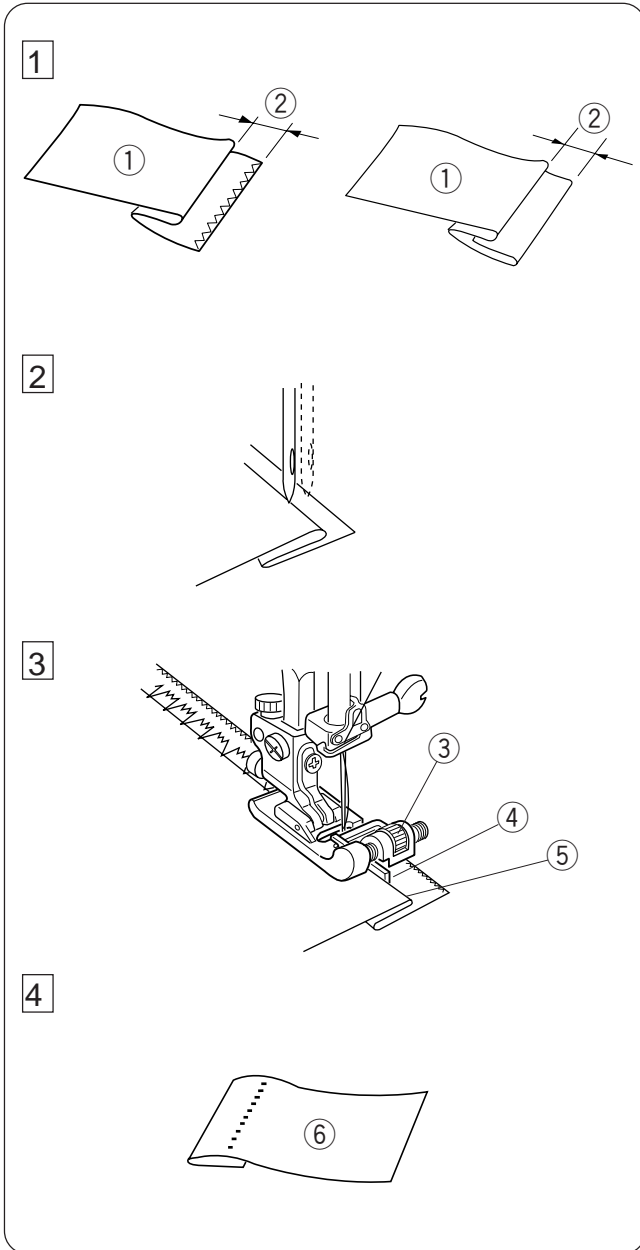

- 1 On heavy weight fabrics that ravel, the raw edge should be overcast first.
Fold the hem leaving a 0.4 – 0.7 cm margin as illustrated.

- ① Wrong side of fabric
- ② 0.4~0.7 cm (1/8"~1/4")

- 2 Place the fabric so the needle just pierces the edge of the fold when the needle swings to the left.
Lower the presser foot.

- 3 There is a sliding guide on the blind hem foot that allows you to precisely control where the needle pierces the edge of the fabric fold.
Turn the screw to align the left side of the guide on the foot with the fold.
Sew, guiding the folded edge along the guide on the foot.

- ③ Guide screw
- ④ Guide
- ⑤ Fold edge

- 4 Open the fabric after sewing.
- ⑥ Right side of fabric

* If the needle pierces too far left, the stitches will show on the right side of the fabric.

NOTE:

When sewing a blind hem with the zigzag foot, carefully guide the fabric so the needle just pierces the edge of the fold.

DECORATIVE STITCHES

Knit Stitch

Machine Settings

- ① Pattern: #13
- ② Presser foot: Zigzag foot A

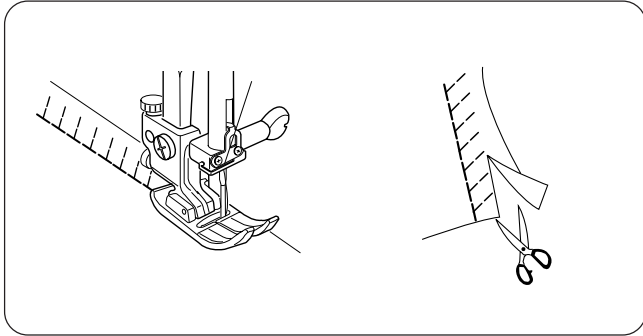
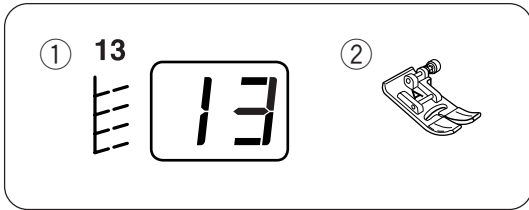

This stitch is recommended for sewing such fabrics as synthetic knits and stretch velour as it provides the greatest amount of elasticity and strength.

Sew along the fabric edge leaving an adequate seam allowance. After sewing, trim off the seam allowance close to the stitches.

Shell Tucking

Machine Settings

- ① Pattern: #17
- ② Presser foot: Satin stitch foot F
- ③ Thread tension: 6-8

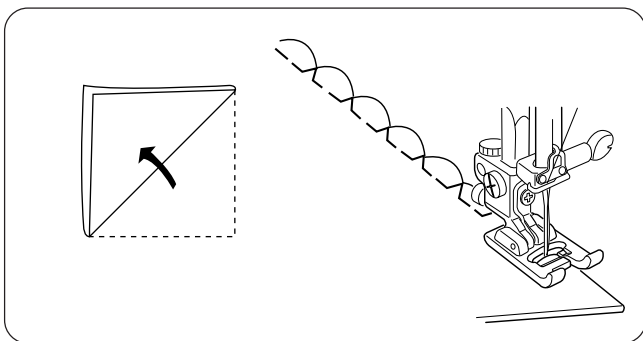
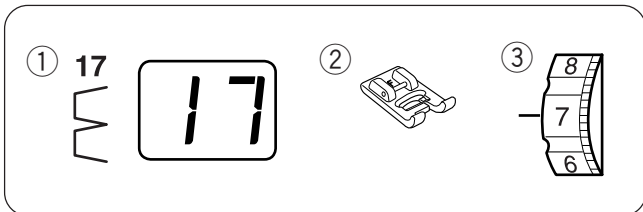

Increase the needle thread tension to "6-8".

Fold and stitch on the bias.

Place the folded edge of the fabric along the slit of the foot so that the right swing of the needle falls off the edge of the fabric to form tucks.

After sewing, open the fabric and iron tucks to one side.

Satin Stitch

Machine Settings

- ① Pattern: #22 to #27
- ② Presser foot: Satin stitch foot F

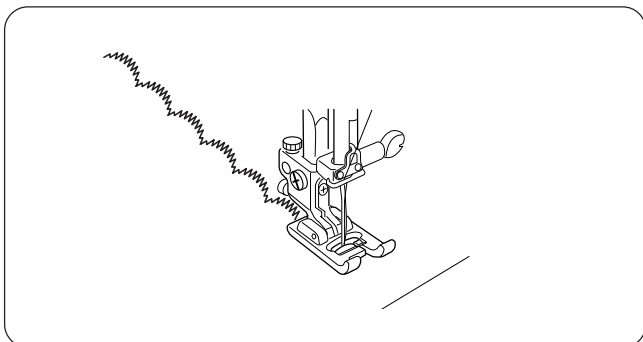
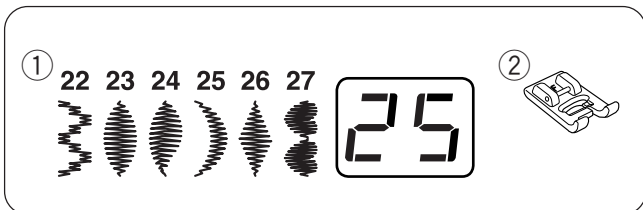

For better sewing results, interfacing should be used on the wrong side of fabric on stretch or elastic fabrics.

Press auto-lock button while sewing the last pattern, and machine will stop automatically after the last pattern is finished.

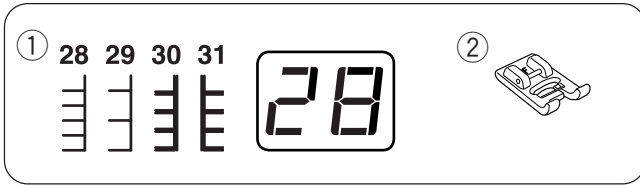

Applique Sewing

Machine Settings

- ① Pattern: #28 to #31
- ② Presser foot: Satin stitch foot F

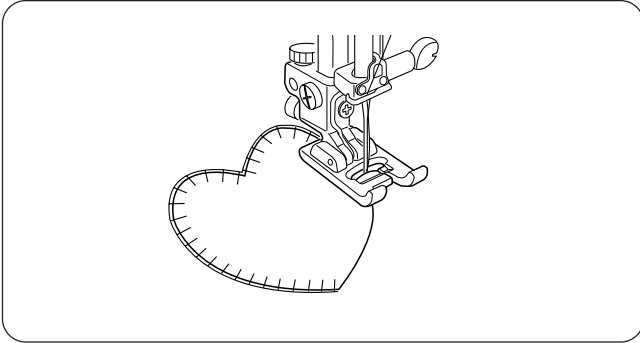

Place the applique on the fabric and baste it in place. Sew, guiding the edge of the applique along the slit on the foot, so that the needle falls off the edge of the applique when it swings to the right.

NOTE:

When changing the sewing direction at a corner or curve, lower the needle into the applique at the left swing and turn the fabric to a new direction.

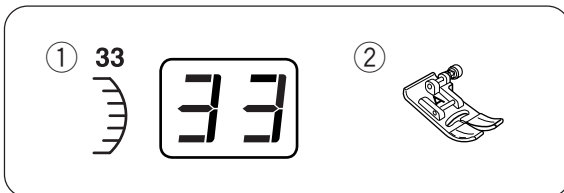

Scallop Stitch

Machine Settings

- ① Pattern: #33
- ② Presser foot: Zigzag foot A

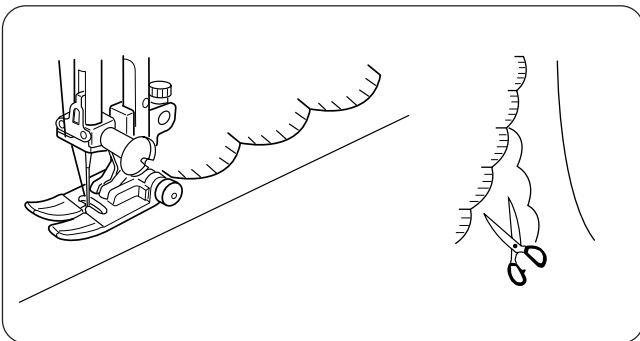

Starting to sew

Sew the stitches approximately 3/8" (1 cm) inside of the edge of fabric.

Trim the outside of the stitches as shown.

* Make sure you don't cut the thread.



Patchwork

Machine Settings

- ① Pattern: #34 or #38
- ② Presser foot: Satin stitch foot F

38

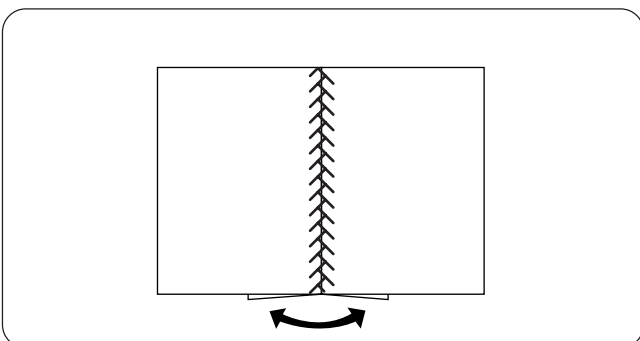

Sew the seam with straight stitch and press seam allowance to open. Sew pattern #34 or #38 on the right side of garment centering over the seam line.

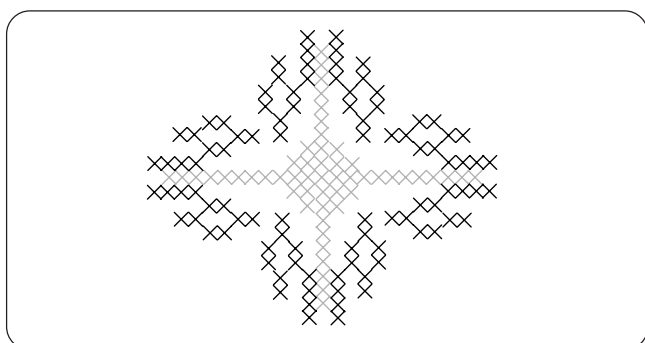
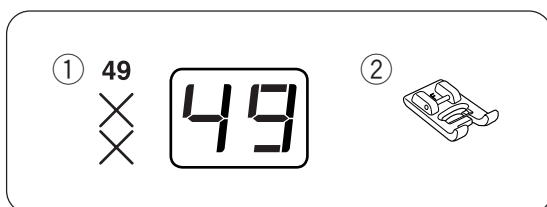
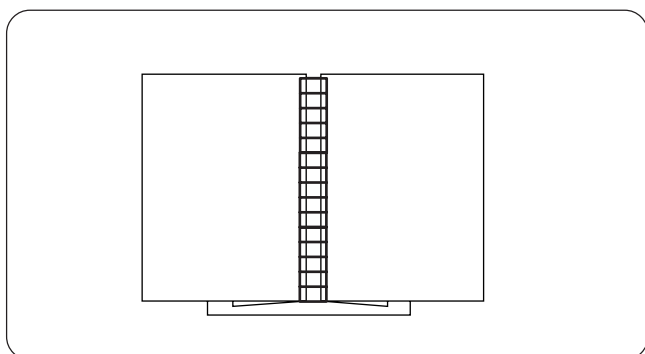
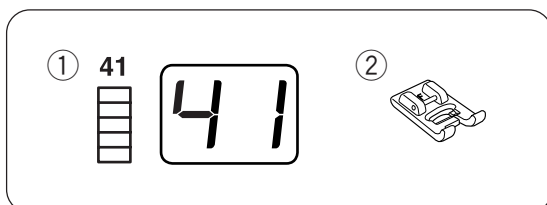
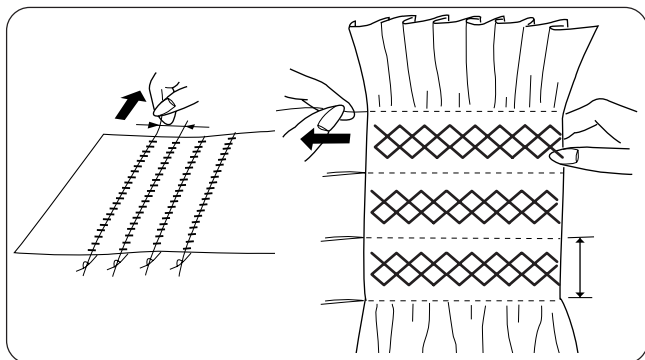

Smocking

Machine Settings

- ① Pattern: #36 or #43 to #45
- ② Presser foot: Satin stitch foot F



Smocking is a delicate, decorative treatment on children's clothes or women's blouses. Choose a soft, lightweight fabric such as batiste, gingham or challis. Cut the fabric three times the projected width. Set the stitch length at 4.0 and sew straight lines 3/8" (1cm) apart across the area to be smocked. A looser needle thread tension will make gathering easier. Knot the threads along one edge. From the other end, pull the bobbin threads to distribute the gathers evenly. Secure the threads at the other end. Sew the smocking stitches between the straight seams. Remove the straight stitches by pulling them out.

Fagoting

Machine Settings

- ① Pattern: #41 or #42
- ② Presser foot: Satin stitch foot F



Use this stitch to join two pieces of fabric to create an open work appearance and add design interest. Fold under each fabric edge 5/8" (1.5 cm) and press. Pin the two edges to paper or tear away backing 1/8" apart. Sew slowly, guiding the fabric so the needle catches the folded edge on each side. After finishing the sewing, take off the paper.

Cross Stitch

Machine Settings

- ① Pattern: #49
- ② Presser foot: Satin stitch foot F

You can make cross stitch designs with this pattern, in half the time it would take if embroidered by hand. To alter the size of cross stitch pattern, activate stitch adjustment mode and press the plus (+) or minus (-) key. * If you press the auto lock button before sewing, the machine will sew one unit of the cross stitch and stop automatically.

Pattern Combination

Machine Settings

- ① Pattern: #27 and #47 (example)
- ② Presser foot: Satin stitch foot F

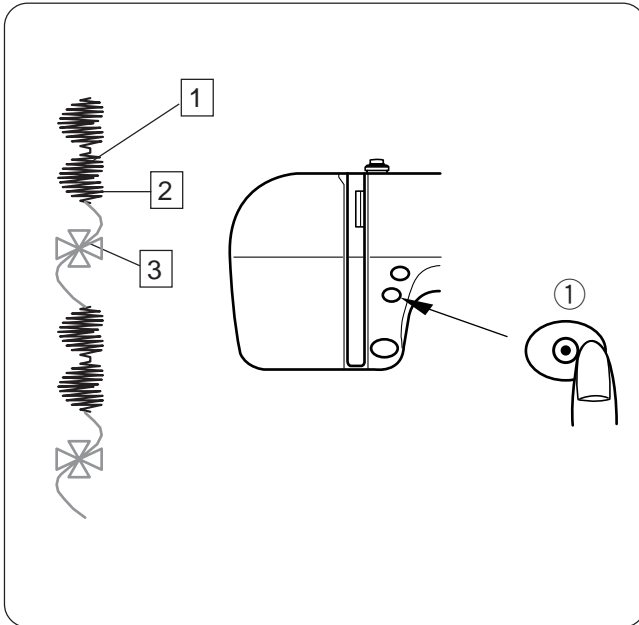
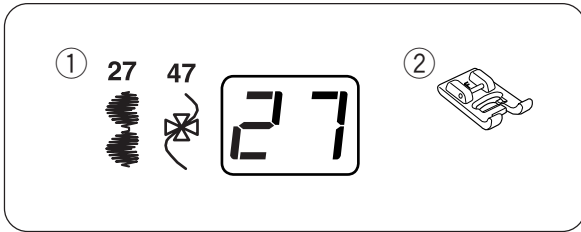

To combine 2 units of pattern #27 and one unit of pattern #47:

- 1 Sew pattern #27 and press the auto-lock button while sewing the second unit. The machine will stop automatically when the second unit is completed.
 - ① Auto-lock button
- 2 Select pattern #47. Press the auto-lock button and start sewing.
- 3 Machine will sew one unit of pattern #47 and stop automatically.
- 4 Repeat steps above.

Correcting Distorted Stretch Patterns

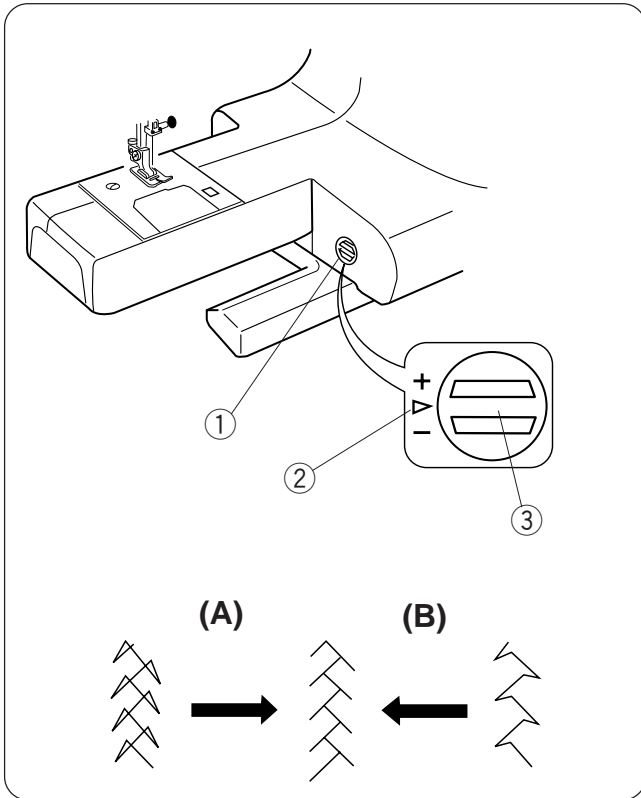

The sewing results of the stretch patterns may vary depending upon the sewing conditions, such as sewing speed, type of the fabric, number of layers etc.

Always test sew on a scrap piece of the fabric that you wish to use.

If stretch stitch patterns are distorted, correct it with the feed balancing dial.

- ① Feed balancing dial
- ② Neutral position
- ③ Setting mark

Example: Pattern #34 

(A): If the pattern is compressed, turn the feed balancing dial in the direction of “+”.

(B): If the pattern is drawn out, turn the feed balancing dial in the direction of “-”.

CARE AND MAINTENANCE

Replacing the Light Bulb



WARNING:

Turn the power off before replacing the light bulb. The bulb could be **HOT**, wait until it has cooled down before touching it.

To remove:

Remove the cap and setscrew.

Unhook the hook from the rear cover and remove the faceplate.

- ① Cap
- ② Setscrew
- ③ Rear cover
- ④ Hook
- ⑤ Face plate

Pull out the light bulb from the lamp socket.

- ⑥ Light bulb
- ⑦ Lamp socket

To replace:

Insert the bulb into the opening of the socket. Attach the face plate inserting the ribs and hook into the rear cover. Secure the face plate with the setscrew, and attach the cap.

NOTE:

Replace the bulb with the same type rated 12V, 5W (part number 000026002).

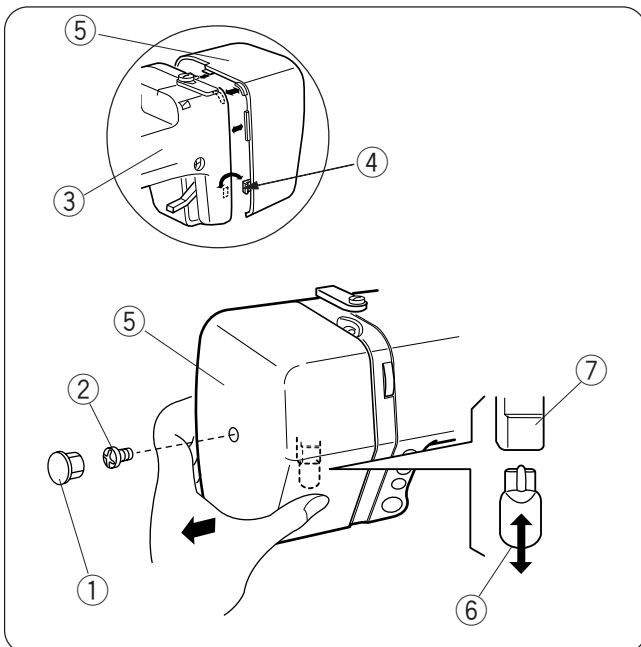

Cleaning the Hook Race

WARNING:

Turn the power switch off and unplug the machine before cleaning.

NOTE:

Do not dismantle the machine in any way other than what is explained in this section.

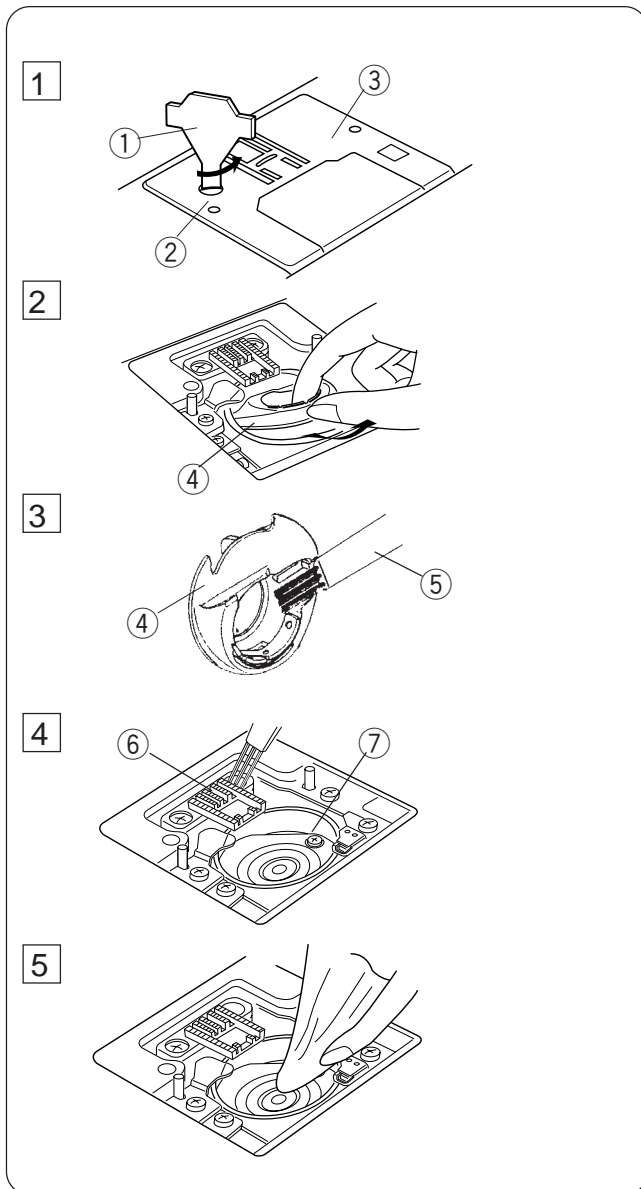

- 1 Remove the setscrew on the needle plate with a screwdriver. Remove the needle plate.
 - ① Screwdriver
 - ② Setscrew
 - ③ Needle plate
- 2 Take out the bobbin. Lift up the bobbin holder and remove it.
 - ④ Bobbin holder
- 3 Clean the bobbin holder with a lint brush.
 - ⑤ Lint brush
- 4 Clean the feed dog and hook race with the lint brush.
 - ⑥ Feed dog
 - ⑦ Hook race
- 5 Clean the hook race with a soft dry cloth. (You may also use a vacuum cleaner.)

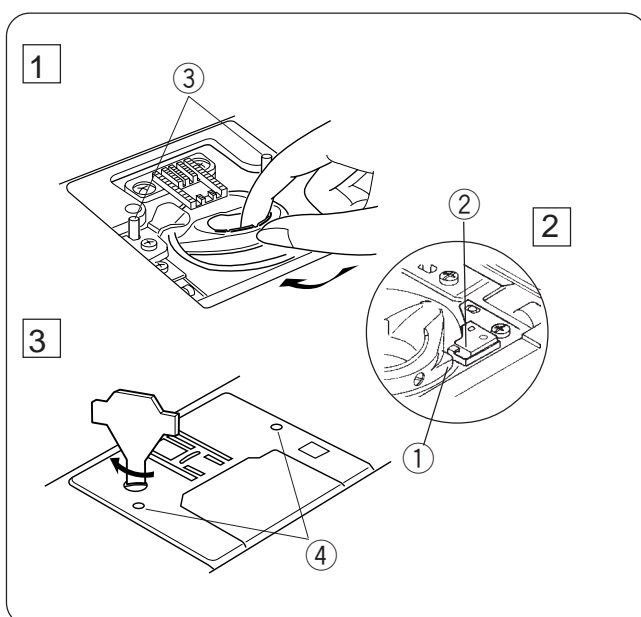

Inserting the bobbin holder





- 1 Insert the bobbin holder.
- 2 The knob of the bobbin holder should fit next to the stopper in the hook race.
 - ① Knob
 - ② Stopper
- 3 Reattach the needle plate, aligning the needle plate guide pins with the guide holes in the needle plate and tighten the setscrew.
 - ③ Guide pins
 - ④ Guide holes

NOTE:

After cleaning the machine, make sure the needle and presser foot are attached.

Problems and Warning Signals

If a buzzer sounds and the indicator shows a warning sign, follow the guidance below.

Warning signal	Problem	Try this
	The power is turned on with the foot control not being connected. The foot control is disconnected while sewing.	Connect the foot control and restart the machine.
	The machine is re-started too soon after it has halted due to the overload.	Wait for at least 15 seconds to restart. If threads are jamming, remove jammed threads.
	Selecting a pattern after buttonhole is completed with the buttonhole lever still lowered.	Raise the buttonhole lever and re-select the pattern.
	The bobbin winder spindle is shifted to the right for bobbin winding.	Return the bobbin winder spindle to the left.
	The machine is malfunctioning due to a problem in the electronic components.	Contact the service center or the store from where the machine was purchased.

Audible signal	The buzzer sounds when:
Pip	Normal operation
Pip-pip-pip	Invalid operation
Pip-pip-peep	Buttonhole sewing completed
Peep	Malfunction

It is not abnormal that a faint humming sound is coming out from the internal motors.

The pattern selection key area may become warm when the machine has been used for hours.

Troubleshooting

Condition	Cause	Reference
The needle thread breaks.	<ol style="list-style-type: none"> 1. The needle thread is not threaded properly. 2. The needle thread tension is too tight. 3. The needle is bent or blunt. 4. The needle is incorrectly inserted. 5. The needle thread and the bobbin thread are not set properly under (drawn to the rear of) the presser foot when sewing is starting. 6. The fabric is not drawn to the rear when sewing is finished. 7. The thread is too heavy or too fine for the needle. 	Page 12 Page 8 Page 9 Page 9 Page 14 Page 14 Page 9
The bobbin thread breaks.	<ol style="list-style-type: none"> 1. The bobbin thread is not threaded properly in the bobbin holder. 2. Lint has collected in the bobbin holder. 3. The bobbin is damaged and doesn't turn smoothly. 4. The thread is wound loosely on the bobbin. 	Page 11 Page 37 Replace the bobbin Re-wind the bobbin.
The needle breaks.	<ol style="list-style-type: none"> 1. Needle is incorrectly inserted. 2. The needle is bent or blunt. 3. The needle clamp screw is too loose. 4. A proper foot is not used. 5. The fabric is not drawn to the rear when sewing is finished. 6. The needle is too fine for the fabric being sewn. 	Page 9 Page 9 Page 9 Use proper foot. Page 14 Page 9
The needle thread loops.	<ol style="list-style-type: none"> 1. The needle thread tension is too loose. 2. The needle size is not suitable for the thread. 	Page 8 Page 9
Skipped stitches	<ol style="list-style-type: none"> 1. The needle is incorrectly inserted. 2. The needle is bent or blunt. 3. The needle and/or thread are not suitable for the fabric being sewn. 4. A blue needle is not being used for sewing stretch, very fine fabrics and synthetics. 5. The needle thread is not threaded properly. 6. A poor quality needle is used. 	Page 9 Page 9 Page 9 Page 9 Page 12 Replace the needle
Seam puckering	<ol style="list-style-type: none"> 1. The needle thread tension is too tight. 2. The needle thread is not threaded properly. 3. The needle is too heavy for the fabric being sewn. 4. The stitch length is too long for the fabric. <p>* Use a stabilizer for very fine fabrics.</p>	Page 8 Page 12 Page 9 Make stitch shorter
The cloth is not fed smoothly.	<ol style="list-style-type: none"> 1. The feed dog is packed with lint. 2. The stitches are too fine. 3. The feed dog was not raised after being lowered. 	Page 37 Make stitch longer Page 7
The machine does not work.	<ol style="list-style-type: none"> 1. The machine is not plugged in. 2. Thread is caught in the hook race. 3. The bobbin winder spindle is still in the winding position. 	Page 4 Page 37 Page 10
Patterns are distorted.	<ol style="list-style-type: none"> 1. The stitch is not balanced. 	Page 36
The buttonhole is not sewn well.	<ol style="list-style-type: none"> 1. The stitch density is not suitable for the fabric being sewn. 2. Interfacing is not being used with stretch fabrics. 	Page 24 Page 21
Noisy operation	<ol style="list-style-type: none"> 1. The feed dog is packed with lint. 2. Lint has collected in the bobbin holder. 	Page 37 Page 37

Due to heat from the internal electronic components, the indicator and function keys will be warm. However, it does not affect the machine's normal operation.

JANOME

843-800-728 (E)
Printed in Taiwan

Free Manuals Download Website

<http://myh66.com>

<http://usermanuals.us>

<http://www.somanuals.com>

<http://www.4manuals.cc>

<http://www.manual-lib.com>

<http://www.404manual.com>

<http://www.luxmanual.com>

<http://aubethermostatmanual.com>

Golf course search by state

<http://golfingnear.com>

Email search by domain

<http://emailbydomain.com>

Auto manuals search

<http://auto.somanuals.com>

TV manuals search

<http://tv.somanuals.com>