



STAINLESS STEEL LP GAS GRILL

MODEL NO.: 720-0511

ITEM NO: 242609

Jenn-Air is a Trademark of the Maytag Corporation and is used under license to Lowe's Companies, Incorporated.

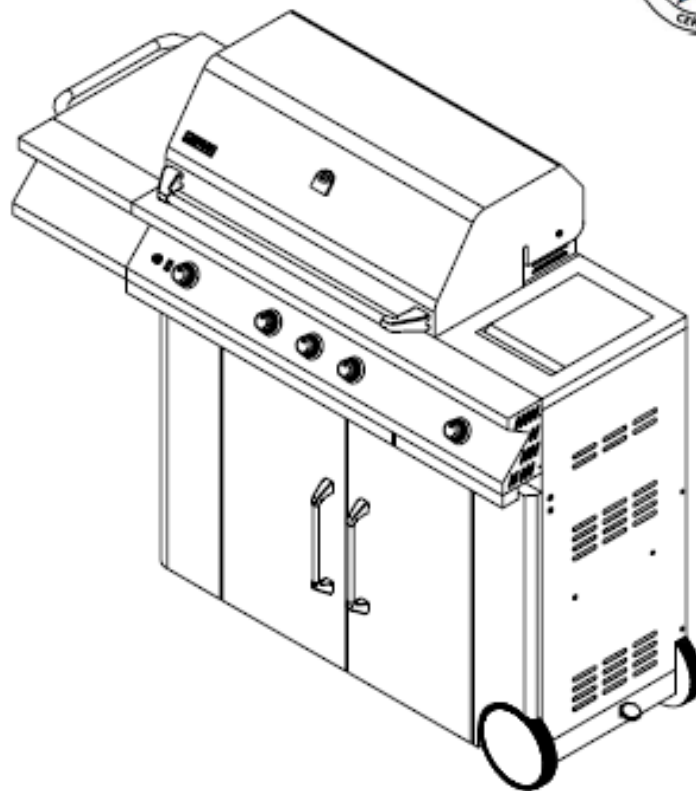

FOR OUTDOOR USE ONLY

G18Y07P-02



**PLEASE CONTACT 1-800-554-5799 FOR ASSISTANCE
DO NOT RETURN TO PLACE OF PURCHASE**

TABLE OF CONTENTS

SECTION ONE		SECTION FIVE	
Safety Instructions.....	1-5	Exploded View.....	24
Placement of the Grill	5	Parts List.....	25-26
SECTION TWO		SECTION SIX	
Side Shelf & Side Burner Assembly.....	6	Grilling Hints.....	27
Side Shelf Handle Assembly & Battery Installation.....	7	Grill Cooking Chart.....	27-29
Braking System Operations & Liquid Propane Cylinder Retention System.....	8	Grill Recipe Suggestions.....	30-31
Slide-Out Tray Locking System & Propane Regulator Hook-Up.....	9	SECTION SEVEN	
SECTION THREE		Limited Warranty.....	
Gas Hook Up.....	10-11	32	
Leak Testing.....	11		
Installer Final Check.....	12		
SECTION FOUR			
Operating Instructions.....	13-14		
Lighting Instructions.....	14		
Lighting Illustrations.....	15		
To Match Light the Grill.....	16-18		
Grill Lights.....	19-20		
Using the Side Burner.....	21		
Care & Maintenance of Side Burner.....	21		
Care & Maintenance of Grill.....	22		
Troubleshooting	23		

 **WARNING**

To reduce the risk of fire, burn hazard or other injury, read this Care and Use Manual carefully and completely before using your grill.

SAFETY INSTRUCTIONS

RECOGNIZED SAFETY SYMBOLS, WORDS AND LABELS

 **WARNING**

WARNING – Hazards or unsafe practices which COULD result in severe personal injury or death.

 **CAUTION**

CAUTION – Hazards or unsafe practices which COULD result in minor personal injury.

 **WARNING**

Do not try lighting this appliance without first reading the “LIGHTING INSTRUCTIONS” section of this manual.

 **WARNING**

Spiders and insects can nest inside the burners of the grill and disrupt gas flow. This very dangerous condition could cause a fire behind the valve panel, thereby damaging the grill and making it unsafe for operation.
Inspect the grill at least twice a year.

 **WARNING**

1. Do not store spare liquid propane cylinders under or near this appliance.
2. Never fill the cylinder beyond 80 percent capacity.
3. If the information above is not followed exactly, a fire resulting in death or serious injury could occur.

 **WARNING**

Never attempt to use damaged or obstructed equipment. See your local liquid propane dealer for repair.

 **WARNING**

Check all gas supply fittings for leaks before each use. Do not use the grill until all connections have been checked and do not leak. Do not smoke while leak testing. Never leak test with an open flame.

 **WARNING**

This grill is not intended to be installed in or on recreational vehicles and/or boats.

 **WARNING**

If you smell gas:

1. Shut off gas to the appliance.
2. Extinguish any open flame.
3. Open lid.
4. If odor continues, keep away from the appliance and immediately call your gas supplier or your fire department.

 **WARNING**

The rotisserie motor is equipped with a plug and should be plugged directly into a properly grounded receptacle in accordance with local codes or, in the absence of local codes, with the National Electrical Code, ANSI/NFPA 70, or the Canadian Electrical Code, CSA C22.1. DO NOT cut or remove the grounding prong from this plug. Keep any electrical supply cord and the fuel supply hose away from any heated surface. Keep the rotisserie motor electric cord away from the heated surfaces of the grill. When not in use remove and store the motor in a dry location.

 **WARNING**

1. Do not store or use gasoline or other flammable vapors and liquids in the vicinity of this or any other appliance.
2. An LP cylinder not connected for use shall not be stored in the vicinity of this or any other appliance.

SAFETY INSTRUCTIONS

WARNING

Do not use the grill if the odor of gas is present. Contact customer service at 1-800-554-5799.

WARNING

When lighting, keep your face and hands as far away from the grill as possible.

WARNING

1. Attach the coupling half (socket) to the gas supply line in accordance with NFPA54/ANSI Z223.1 FUEL gas code.
2. Prior to inserting the plug, test the connection for leaks following the leak test instructions on page 11. After the leak test is completed, rinse the connection with clean water to remove any corrosive residue.
3. Do not use open flame to test for leaks.

WARNING

Storage of an outdoor cooking gas appliance indoor is permissible only if the cylinder is disconnected and removed from the outdoor cooking gas appliance.

WARNING

Do not install this unit into combustible enclosures. There should be a minimum clearance of 24 inches from all sides to combustible materials. Outdoor cooking appliance shall not be used under overhead combustible construction.

WARNING

Keep any electrical supply cord away from any heated surface.

WARNING

Make sure the light switch is on "OFF" position and power plug is disconnected from power outlet prior to cleaning the glass cover.

CAUTION

When using the rotisserie burner, remove the warming rack. High heat from the burner may cause the warming rack to bend.

WARNING

Failure to properly place the burner over the orifice could cause a fire to occur behind and beneath the valve panel, thereby damaging the grill and making it unsafe to operate.

WARNING

Do not leave the grill unattended while cooking.

WARNING

Cylinder must be stored outdoors out of the reach of children and must not be stored in a building, garage or any other enclosed area.

WARNING

A tank of approximately 12 inches in diameter by 18-1/2 inches high is the maximum size LP gas tank to use. **You must use an OPD gas tank, which offers an Overfill Prevention Device.**

This safety feature prevents the tank from being overfilled, which can cause malfunction of the LP gas tank, regulator and/or grill.

WARNING

The light glass cover should not be in contact with water or any other liquid when it's warm. Sudden change of temperature may cause cracks on glass

WARNING

To ensure continued protection against electric shock:

1. Connect to properly grounded outlets only.
2. Do not expose to rain.
3. Keep extension cord connections dry and off the ground.

CAUTION

Before cleaning, make sure the gas supply and control knobs are in the "OFF" position and the burners have cooled.

CAUTION

When using a match to light the grill make sure to use the attached lighting rod.

SAFETY INSTRUCTIONS



WARNING

Do not attempt to light the grill if gas odor is present. Contact customer service at 1-800-554-5799.

When lighting, keep your face and body as far away from the burner as possible.

BEFORE LIGHTING

Inspect the gas supply hose prior to turning on the gas. If there is evidence of cuts, wear, or abrasion, it must be replaced prior to use.

Only the pressure regulator and hose assembly supplied with the unit should be used. Never substitute regulators for those supplied with the grill. Contact customer service for proper replacement.

Screw the regulator (type QCC1) onto the cylinder. Leak check the hose and regulator connections with a soap and water solution before operating the grill (See "Leak Testing" instructions on page 11).

Do not turn "ON" the gas at the LP gas cylinder unless the Quick-Connect gas hose is properly connected to the side burner gas pipe system and all burner valves are in the "OFF" position.



LP GAS CYLINDER WARNING

1. Do not store or use gasoline or other flammable vapors and liquids in the vicinity of this or any other appliance.
2. A liquid propane cylinder not connected for use should not be stored in the vicinity of this or any other appliance.
3. Do not store spare liquid propane gas cylinders under or near this appliance.
4. Never fill the cylinder beyond 80 percent capacity.
5. Liquid propane cylinders must be fitted with an Overfill Protection Device (OPD).
6. If the information above is not followed exactly, a fire causing death or serious injury may occur.

USING THE SIDE BURNER

Inspect the gas supply hose prior to turning on the gas. If there is evidence of cuts, wear or abrasion, it must be replaced prior to use. Do not use the side burner if gas odor is present.

Keep a spray bottle of soapy water near the grill and check the connections before each use.

ROTISSERIE DRIVE MOTOR

To ensure continued protection against electric shock:

Connect to properly grounded outlets only.

Keep extension cord connections dry and off the ground.

Do not expose to rain.

Do not use indoors.



WARNING

If you smell gas:

1. Shut off gas to the grill.
2. Extinguish any open flames.
3. Open the top cover or lid.
4. If the odor continues, keep away from the appliance and immediately call your gas supplier or local fire department.

SAFETY INSTRUCTIONS

WARNING

Do not try lighting this appliance without first reading the "LIGHTING INSTRUCTIONS" section of this manual.

TESTED IN ACCORDANCE WITH ANSI Z21.58 - 2007 LATEST STANDARD and CSA 1.6-2007 STANDARD FOR OUTDOOR COOKING GAS APPLIANCES. THIS GRILL IS FOR OUTDOOR USE ONLY.

Check your local building codes for the proper method of installation. In the absence of local codes, with either the National Fuel Gas Code, ANSI Z223.1/NFPA 54, or CAN/CGA-B149.1, Natural Gas and propane Installation Code. Electrical Code, ANSI/NFPA 70.

CALIFORNIA PROPOSITION 65-WARNING

The burning of gas fuel generates some by-products, which are known by the State of California to cause cancer or reproductive harm. To minimize exposure to these substances, always operate this unit according to the care and use manual, ensuring you provide good ventilation when cooking with gas.

SAFETY PRACTICES TO AVOID INJURY

When properly cared for, your grill will provide safe, reliable service for many years. However, extreme care must be used as the grill produces intense heat that can increase accident potential.

When using this appliance basic safety practices must be followed, including the following:

Do not repair or replace any part of the grill unless specifically recommended in this manual. All other service should be referred to a qualified technician.

The grill is for outdoor use only.

The grill is not intended to be installed in or on recreational vehicles and/or boats.

Children should not be left alone or unattended in an area where the grill is being used. Do not allow children to sit, stand or play on or around the grill at any time.

Do not store items of interest to children around or below the grill or cart. Do not allow children to crawl inside the cart.

Never let clothing, pot holders or other flammable materials come in contact with or too close to any grate, burner or hot surface until it has cooled. The fabric could ignite, causing serious personal injury.

For personal safety, wear proper apparel. Loose fitting garments or sleeves should never be worn while using this appliance. Some synthetic fabrics are highly flammable and should not be worn while cooking.

Only certain types of glass, ceramic, earthenware, or other glazed utensils are suitable for grill use. Other types of materials may shatter with sudden temperature changes. Use only low or medium heat settings in accordance with the manufacturer's guidelines.

Do not heat unopened food containers as a build-up of pressure may cause the containers to burst.

Use a covered hand when opening the grill lid. Never lean over an open grill.

When lighting a burner, always pay close attention to what you are doing. Make certain you are aware of which burner you are lighting so that your body and clothing remain clear of open flames.

SAFETY INSTRUCTIONS

When using the grill, do not touch the grill rack, burner grate or immediate surroundings as these areas become extremely hot and could cause burns. Use only dry potholders. Moist or damp potholders on hot surfaces may cause steam burns. Do not use a towel or bulky cloth in place of potholders. Do not allow potholders to touch hot portions of the grill rack.

Grease is flammable. Let hot grease cool before attempting to handle it. Do not allow grease deposits to collect in the grease tray at the bottom of the grill's firebox. Clean the grease tray often.

Do not use aluminum foil to line the grill racks or grill bottom. This can severely upset combustion air flow or trap excessive heat in the control area.

For proper lighting and performance of the burners, keep the burner ports clean. It is necessary to clean them periodically for optimum performance. The burners will only operate in one position and must be mounted correctly for safe operation.

Clean the grill with caution. To avoid steam burns, do not use a wet sponge or cloth to clean the grill while it is hot. Some cleaners produce noxious fumes or can ignite if applied to a hot surface.



INSECT WARNING

Spiders and other insects can nest inside the burners of this and other grills, which could disrupt gas flow. This dangerous condition could cause a fire behind and beneath the valve panel, damaging the grill and making it unsafe for operation.

Inspect the grill at least twice a year.

Never use a dented or rusty propane cylinder.

Turn off all control knobs and make certain the grill is cool before using any type of aerosol cleaner on or around it. The chemical that produces the spraying action could, in the presence of heat, ignite or cause metal parts to corrode.

Do not use the grill to cook excessively fatty meats or other products that promote flare-ups.

Do not operate the grill under unprotected combustible constructions. Use only in well-ventilated areas. Do not use in buildings, garages, sheds, breezeways or other such enclosed areas.

This unit is intended for outdoor use only.

Keep the areas surrounding the grill free from combustible materials including, fluids, trash, and vapors such as gasoline or charcoal lighter fluid. Do not obstruct the flow of combustion and ventilation air. If the unit is stored indoors, make sure it is cool.

Do not use briquettes of any kind in the grill.

The 720-0511 liquid propane gas grill is designed for optimum performance without the use of briquettes. Do not place briquettes on the flame tamers, as this will block the vent to the grill burners. Adding briquettes can damage ignition components, thus voiding the warranty.

Keep the back of the cart free and clear from debris. Keep electrical supply cords and the rotisserie motor cord away from heated areas of the grill.

Never use the grill in extremely windy conditions. If located in a consistently windy area (oceanfront, mountaintop, etc.), a windbreak will be required. Always adhere to the clearance specifications.

PLACEMENT OF THE GRILL

CLEARANCE

Non-Combustible Construction

A minimum of 24 inches clearance from the back of the grill to non-combustible materials are required for the lid to open fully.



WARNING

Do not install this unit into combustible enclosures. There should be a minimum clearance of 24 inches from all sides to combustible materials.

LOCATION

When determining a suitable location take into account concerns such as exposure to wind, proximity to traffic paths, and keeping gas supply lines as short as possible.

Place the grill in well-ventilated areas. Never place the grill in a building, garage, breezeway, shed or other such enclosed areas. During heavy use, the grill will produce a lot of smoke.

SIDE SHELF ASSEMBLY

Estimated Assembly Time: Approximately 10 minutes
Required Tools: Phillips Screwdriver (not included)

1. Remove side shelf from inside grill cart.
2. The screws used to attach the side shelf are already screwed into the side of the grill cart. Remove the screws from the side panels.
3. Align the holes of the left side shelf with those in the grill cart, insert the screws and tighten. **Note:** The top two screws insert from inside the fire box while the bottom two screws insert from under the left side shelf.

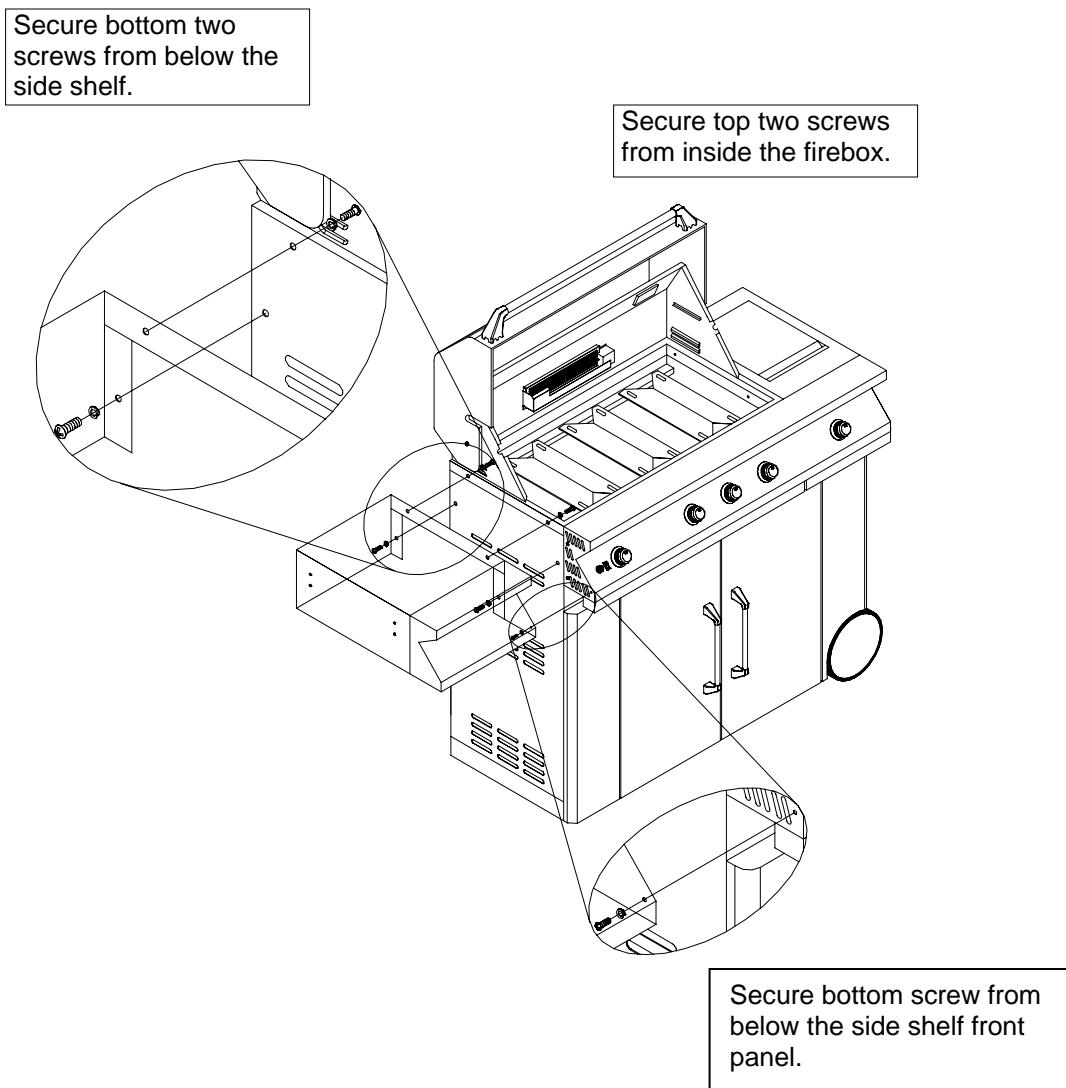

SIDE SHELF HANDLE ASSEMBLY

Estimated Assembly Time: Approximately 5-7 minutes

Required Tools: Phillips Screwdriver (not included)

1. Remove the four side shelf handle screws from the side of the shelf.
2. Align the holes in the side shelf handle with the holes in the side shelf.
3. Insert the screws and tighten.

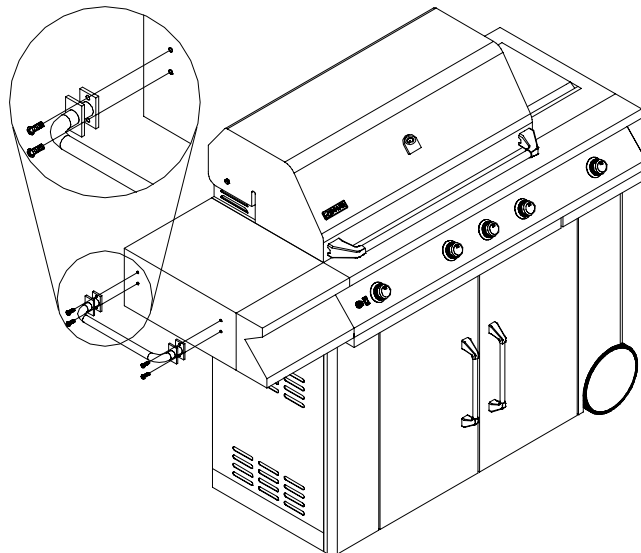

BATTERY INSTALLATION

1. Remove the ignition button housing.
2. Insert the battery into the housing with the positive (+) terminal facing outward.
3. Replace the ignition button housing after the battery has been installed.

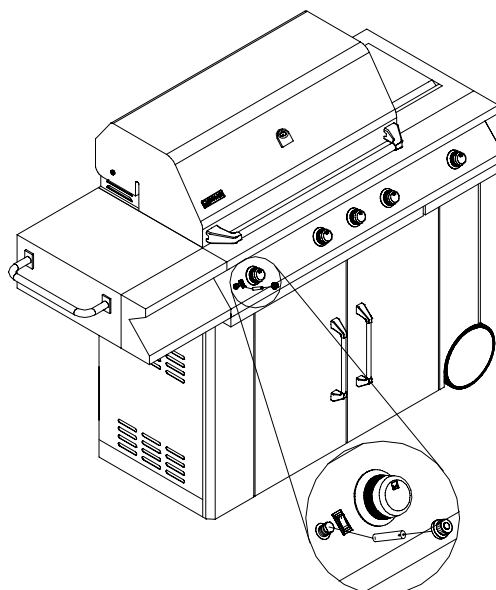

BRAKING SYSTEM OPERATIONS

1. Push to the right to lock.
2. Push to the left to unlock.

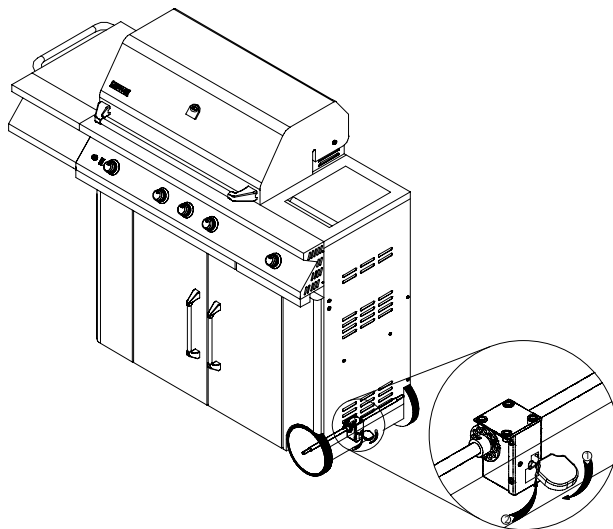

LIQUID PROPANE CYLINDER RETENTION SYSTEM

1. Set the liquid propane gas cylinder into the slide-out tray. Turn the retention screw clockwise to secure the gas cylinder.
2. Make sure tank is leveled with bottom panel for proper vapor withdraw.

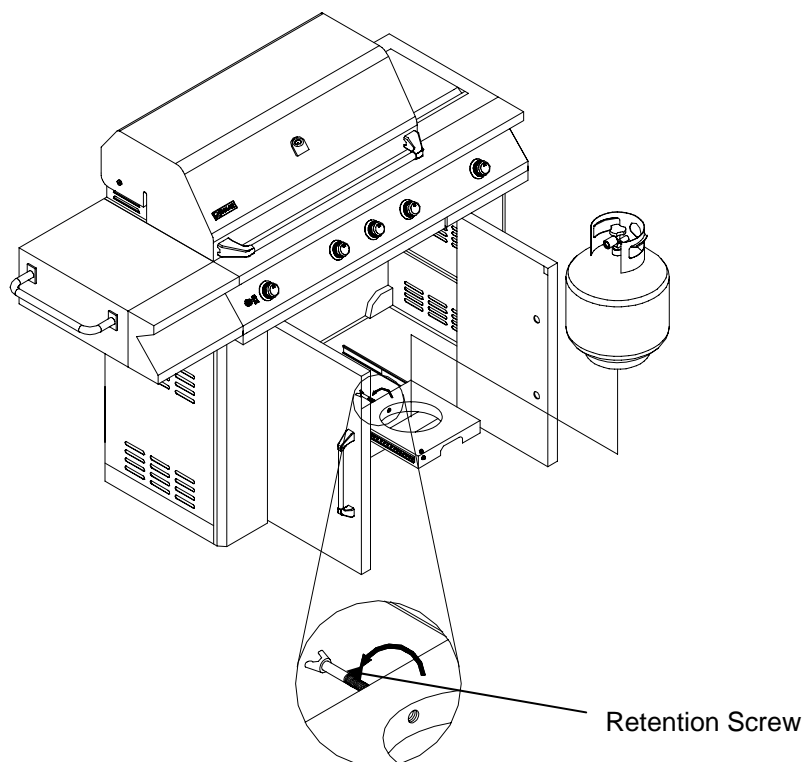

SLIDE-OUT TRAY LOCKING SYSTEM

1. To lock the liquid propane gas cylinder tray, press the button located on the top of the slide-out tray (A).
2. To unlock, press the side button (B) as shown below.

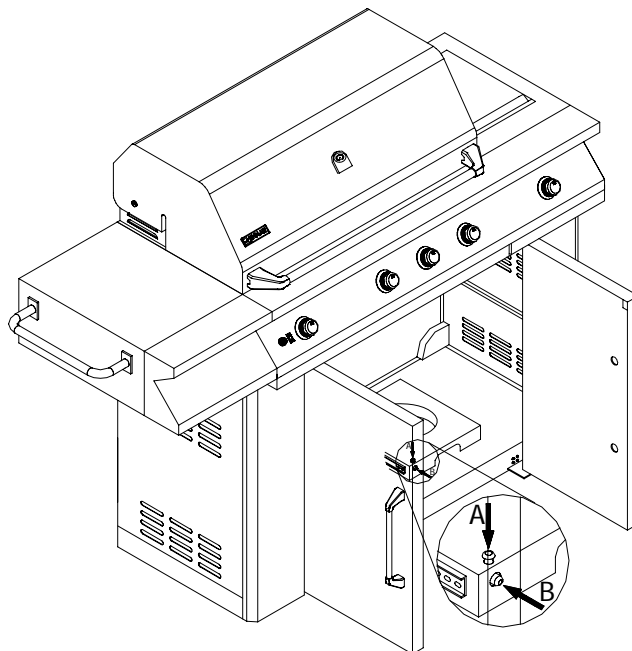

PROPANE REGULATOR HOOK-UP

1. Attach the regulator to the propane cylinder by turning the regulator handle clockwise.
2. Turn off the gas supply at the cylinder when the appliance is not in use.

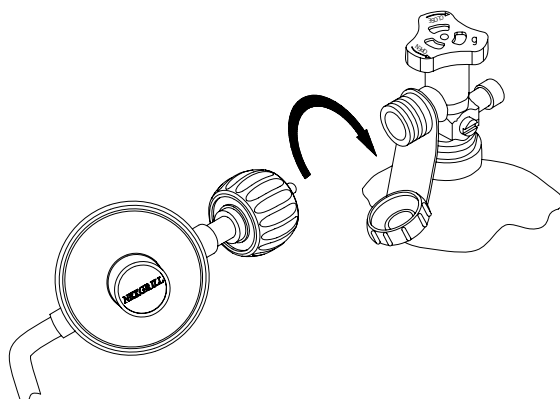

GAS HOOK-UP

Only the pressure regulator and hose assembly supplied with the grill should be used. Any replacement pressure regulator and hose assembly must be specified by the grill manufacturer.

This is a liquid propane configured grill. Do not attempt to use a natural gas supply unless the grill has been pre-configured for natural gas use.

Total gas consumption (per hour) of the 720-0511 liquid propane gas grill with all burners set on "HI":

Main burners	45,000 BTU/Hr.
Rear burner	10,000 BTU/Hr.
Side burner	15,000 BTU/Hr.
Total	70,000 BTU/Hr.

The installation of this appliance must conform with local codes or, in the absence of local codes, with either the National Fuel Gas Code, ANSI Z223.1/NFPA 54, National Gas Propane Installation Code, CSA B149.2.

Installation in Canada must be in accordance with the Standard CSA-B149.2 (installation code for gas burning appliances and equipment) and local codes.

LIQUID PROPANE CYLINDER REQUIREMENTS (20 lb. Cylinder)

A dented or rusty liquid propane gas cylinder may be hazardous and should be checked by your supplier. Never use a cylinder with a damaged valve. The liquid propane cylinder must be constructed and marked in accordance with the specifications for liquid propane cylinders by the United States Department of Transportation (DOT) or the National Standard of Canada, CAN/CSA-B339, Cylinders, Spheres and Tubes for Transportation of Dangerous Goods Commission.

The 20 lb. cylinder must have a shut off valve terminating in a valve outlet specified, as applicable, for connection type QCC1 in the standard for compressed gas cylinder valve outlet and inlet connection ANSI/CGA-V-1.

The cylinder supply system must be arranged for vapor withdrawal. The cylinder must include a collar to protect the cylinder valve.

Storage of an outdoor cooking gas appliance indoors is permissible only if the liquid propane cylinder is disconnected and removed from the appliance.

Manifold pressure: (operating) 10 inches water column (W.C.), (non-operating) 11.2 inches water column (W.C.).

The liquid propane cylinder must be fitted with an Overfill Protection Device (OPD).

Remove the plastic valve cover from the liquid propane cylinder. Make sure the grill's gas hoses do not contact the grease tray or grill firebox when the liquid propane cylinder is pushed into the cart.

CONNECTION

Your grill is equipped with gas supply orifices for use only with liquid propane gas. It is also equipped with a high capacity hose/regulator assembly for connection to a standard 20 lb. liquid propane cylinder (18-1/4 inches high, 12-1/4 inches diameter).

To connect the liquid propane gas supply cylinder:

1. The cylinder valve should be in the "OFF" position. If not, turn the valve clockwise until it stops.
2. Make sure the cylinder valve has the proper type 1 external male thread connections per ANSIZ21.81.
3. Make sure the burner valves are in the "OFF" position.
4. Inspect the valve connections, port and regulator assembly. Look for any damage or debris. Remove debris and inspect the hose for damage.
5. When connecting the regulator assembly to the valve, use your hand to tighten the nut clockwise until it stops. Use of a wrench could damage the quick coupling nut and result in a hazardous situation
6. Open the cylinder valve fully by turning the valve counterclockwise.
7. Before lighting the grill, use a soap and water solution to check all the connections for leaks.
8. If a leak is found, turn the cylinder valve off and do not use the grill until a local liquid propane dealer can make repairs.



WARNING

Never attempt to use damaged or obstructed equipment. See your local liquid propane dealer for repair.

DISCONNECTION

1. Turn off the burner valves and make sure the grill is cool.
2. Turn off the tank valve by turning the control knob clockwise until it stops.

3. Detach the regulator assembly from the tank valve by turning the quick coupling nut counterclockwise.
4. Place the dust cap on the liquid propane cylinder valve outlet when the cylinder is not in use. Only install the type of dust cap that is

provided with the cylinder valve. The use of other caps or plugs may result in propane leakage.

LEAK TESTING

GENERAL

Although gas connections on the grill are leak tested prior to shipment, a complete gas tightness check must be performed at the installation site. Before each use check the whole system for leaks following the procedures listed below.

If the smell of gas is detected at anytime, you should immediately check the entire system for leaks.

BEFORE TESTING

Make sure all packing materials have been removed from the grill, including the burner tie-down straps.



WARNING

Check all gas supply fittings for leaks before each use. Do not use the grill until all connections have been checked and do not leak.

Do not smoke while leak testing.

Never leak test with an open flame.

Make a solution of one part liquid detergent and one part water. You will need a spray bottle, brush, or rag to apply the solution to the fittings. For the initial leak test, make sure the liquid propane cylinder is full.

TO TEST

1. Make sure the control valves are in the "OFF" position, and turn the gas supply "ON".
2. Apply the soap solution to all pipe fittings, from the liquid propane cylinder up to and including the connections to the burners. Soap bubbles will appear where a leak is present.
3. If a leak is present, immediately turn off the gas supply and tighten leaky fittings.
4. Turn the gas back "ON" and recheck.
5. Should the gas continue to leak from any of the fittings, turn off the gas supply and contact customer service at 1-800-554-5799.

6. If it is evident there is excessive abrasion or wear, or the hose is cut, it must be replaced prior to the outdoor cooking gas appliance being put into operation.

Only those parts recommended by the manufacturer should be used on the grill. Substitutions will void the warranty.

GAS FLOW CHECK

Each grill burner is tested and adjusted at the factory prior to shipment. However, variations in the local gas supply may make it necessary to adjust the burners.

Flames should be blue and stable with no yellow tips, excessive noise or lifting.

If any of these conditions exist, first check to see if the burner is blocked by dirt, debris, spider webs, etc. If the burners are clear of foreign objects or debris, please contact customer service at 1-800-554-5799 for further assistance.

Always check for leaks after every liquid propane cylinder change.

It is handy to keep a spray bottle of soapy water near the shut-off valve of the gas supply line. Spray all the fittings. Bubbles indicate leaks.

Disconnected liquid propane cylinders must have threaded valve plugs tightly installed, and must not be stored in a building, garage or any other enclosed area.



WARNING

Storage of an outdoor cooking gas appliance indoor is permissible only if the cylinder is disconnected and removed from the outdoor cooking gas appliance.

The gas must be turned off at the supply cylinder when the unit is not in use.

If the appliance is stored indoors, the cylinder must be disconnected and removed from the appliance. Cylinders must be stored outdoors in a well-ventilated area out of the reach of children.



WARNING

Cylinder must be stored outdoors out of the reach of children and must not be stored in a building, garage or any other enclosed area.

INSTALLER FINAL CHECK



- Specified clearance maintained 24 inches from combustible materials/construction.
- All internal packaging has been removed.
- The hose and regulator are properly connected.
- The unit has been tested and is free of leaks.
- The gas supply shut off valve has been located.
- All burners are factory installed.
- Keep the instruction manual with the grill for future reference.



WARNING

1. Do not store spare liquid propane cylinders under or near this appliance.
2. Never fill the cylinder beyond 80 percent capacity.
3. If the information above is not followed exactly, a fire causing death or serious injury may occur.

OPERATING INSTRUCTIONS

GENERAL USE OF THE GRILL AND ROTISSERIE

Each main burner is rated at 15,000 BTU/Hr. The main grill burners encompass the entire cooking area and are side ported to minimize blockage from falling grease and debris. Above the burners are stainless steel flame tamers. The igniter knobs are located on the lower center portion of the valve panel. Each rotary igniter is labeled on the control panel.

USING THE GRILL

Grilling requires high heat for searing and proper browning. When grilling, take into consideration the meat involved and desired preparation. Large pieces of meat or poultry may need to be cooked at a lower setting after the initial browning. This method cooks the food thoroughly without burning the outside.

Food cooked for a long time or basted with a sugar-based marinade may need a lower heat setting near the end of its cooking time.

To begin:

1. Make sure the grill has been leak tested and is properly placed.
2. Remove any remaining packing materials.
3. Light the grill burners using the instructions on page 14.
4. Turn the control knob(s) to the "HI/IGNITE" setting, and preheat the grill for 15 minutes. The grill lid should be closed during the pre-heat period.
5. Place the food on the grill and cook to the desired preparation. If necessary, adjust the heat setting. The control knob may be positioned at any setting between "HI/IGNITE" and "LO".

USING THE ROTISSERIE BURNER

Your grill is capable of performing back burner rotisserie cooking. Light the rear burner as described in the lighting instructions on page 14. Once lit, the rotisserie burner will reach cooking temperature in about 1 minute.

The rotisserie motor is capable of turning up to a 12 lb. cut of meat or poultry. The motor slides onto the stainless steel motor mount.

The rotisserie motor must be electrically grounded in accordance with local codes or, in the absence of

local codes, with the National Electrical Code, ANSI/NFPA 70-1990.

After its first use, the stainless steel adjacent to the rotisserie burner will most likely turn dark blue. This is a normal property of the non-rusting type stainless steel used on the grill.

WARNING

The rotisserie motor is equipped with a plug and should be plugged directly into a properly grounded receptacle in accordance with local codes or, in the absence of local codes, with the National Electrical Code, ANSI/NFPA 70, or the Canadian Electrical Code, CSA C22.1. DO NOT cut or remove the grounding prong from this plug.

Keep the rotisserie motor cord away from the heated surfaces of the grill. When not in use remove and store the motor in a dry location.

THE ROTISSERIE SKEWER

The skewer for the rotisserie should be assembled into the motor by placing the pointed end into the motor, and then sliding the grooved bushing into the slot at the opposite side of the grill.

The thumbscrew for the grooved bushing should be inside the grill body.

LOADING THE ROTISSERIE SKEWER

1. Screw the bushing onto the skewer rod at the opposite end from the point.
2. Slide and tighten the counterbalance apparatus onto the skewer rod approximately 2 to 4 inches from the bushing.
3. Slide the first meat fork onto the skewer rod, prongs toward the food.
4. Center the product to be cooked on the skewer, and then push the meat forks firmly together.
5. Tighten the wing nuts.
6. It may also be necessary to wrap the food with butcher's string to secure loose portions. Never use nylon or plastic string to wrap the food.
7. Once the food is secure, insert the skewer into the motor.

NOTE

It is normal for the skewer to flex when larger cuts of meat are being cooked.

If the meat scrapes on the cooking grids during any part of the rotation, the cooking grids must be removed. Test this clearance before lighting the grill as the cooking grids become hot when the grill is lit.

Adjust the counterbalance weight to balance the heavier side of the meat and avoid lopsided rotation of the rotisserie motor.

CAUTION

When using the rotisserie burner, remove the warming rack. High heat from the burner may cause the warming rack to bend.

LIGHTING INSTRUCTIONS

BEFORE LIGHTING...

Inspect the gas supply hose prior to turning on the gas. If there is evidence of cuts, wear, or abrasion, it must be replaced prior to use. Refer to "Leak Testing" on page 11.

WARNING

Do not use the grill if the odor of gas is present. Contact customer service at 1-800-554-5799.

Screw the regulator (type QCC1) into the cylinder, and leak check the hose and regulator connections before operating the grill (See the "Leak Testing" instructions on page 11).

Only the pressure regulator and hose assembly supplied with the unit should be used. Never substitute regulators. If a replacement is necessary, contact customer service for proper replacement.

TO LIGHT THE GRILL BURNER

1. Make sure all the knobs are in the "OFF" position, and then turn on the gas supply from the liquid propane cylinder.
2. The electronic ignition is built into the valve. To ignite the main burners, simply press and turn each control knob to the "HI" setting. The ignition system will "click" as the electrode generates a spark. This spark will ignite the burner.
3. If the burner does not light, turn off the gas supply, wait 5 minutes for any excess gas to dissipate and then try again.
4. If the burners still do not light, follow the match lighting instructions on page 16.

FLAME CHARACTERISTICS

Check for proper burner flame characteristics. Each burner is adjusted prior to shipment. However, variations in the local gas supply may make minor adjustments necessary.

Burner flames should be blue and stable with no yellow tips, excessive noise or lifting.

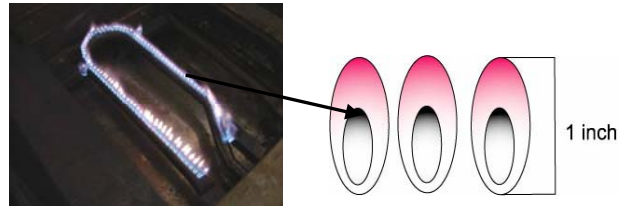

Yellow flames indicate insufficient air. Noisy flames or flames that lift away from the burner indicate too much air (See the "GAS FLOW CHECK" section on page 11).

TO LIGHT THE ROTISSERIE BURNER:

1. Open the lid, and press the knob for about 5 seconds without turning it. This will allow time for gas to flow into the rear burner.
2. The electronic ignition is built into the valve. To ignite the rotisserie burner, simply press and turn the control knob to the "HI" setting. The ignition system will "click" as the electrode generates a spark. This spark will ignite the rotisserie burner.
3. If the burner does not light, turn the control knob to the "OFF" position.
4. If the igniter does not function, follow the instructions on page 18 for match lighting.

TO LIGHT THE SEARING SIDE BURNER:

1. Open the lid, and press searing side burner knob for about 15 seconds without turning it. This will allow time for gas to flow into the side burner.
2. To ignite the searing side burner, simply press and turn the knob to the "HI" setting. There will be a "clicking" sound if the ignition system is working correctly.
3. If the burner does not light, turn the control knob to the "OFF" position.
4. If the igniter does not function, follow the instructions on page 17 for match lighting.

Keep a spray bottle of soapy water near the gas supply valve and check the connections before each use.

LIGHTING ILLUSTRATIONS

MAIN BURNER LIGHTING



1. Open the top cover or lid.



2. Turn the main burner control knobs to the "IGNITE / HI" setting. Push the control knob in until the burner ignites; you should hear a "clicking" sound if the electronic ignition system is working properly. The burner should ignite within 4 seconds (if burner does not ignite follow match lighting instructions on page 16).
3. Once the burner ignites, adjust the temperature level as desired.

ROTISSERIE BURNER & SEARING SIDE BURNER LIGHTING



1. Push and turn rear burner slowly to "INGITE / ON" setting; you should hear a "clicking sound if the electronic ignition system is working properly. The burner should ignite within 4 seconds (if burner does not ignite follow match lighting instructions on page 18).



2. Push and turn searing side burner knob to "IGNITE / HI" setting; you should hear a "clicking sound if the electronic ignition system is working properly. The burner should ignite within 4 seconds (if burner does not ignite follow match lighting instructions on page 17).

TO MATCH LIGHT THE GRILL

If the burner will not light after several attempts using the control knobs, the burner may be lit with a match.

Main Burner

1. If you have already attempted to light the burner with the igniter, allow 5 minutes for any accumulated gas to dissipate.
2. Insert a match into the lighting rod. Ignite the match and insert through the cooking grids to the burner.
3. Press the control knob and rotate left to the "IGNITE/HI" setting, continue to press the knob until the burner ignites. The burner should light immediately.
4. If the burner does not light within 4 seconds turn the knob to the "OFF" position, wait 5 minutes and try again.

WARNING

When lighting, keep your face and hands as far away from the grill as possible.

CAUTION

When using a match to light the grill make sure to use the attached lighting rod.

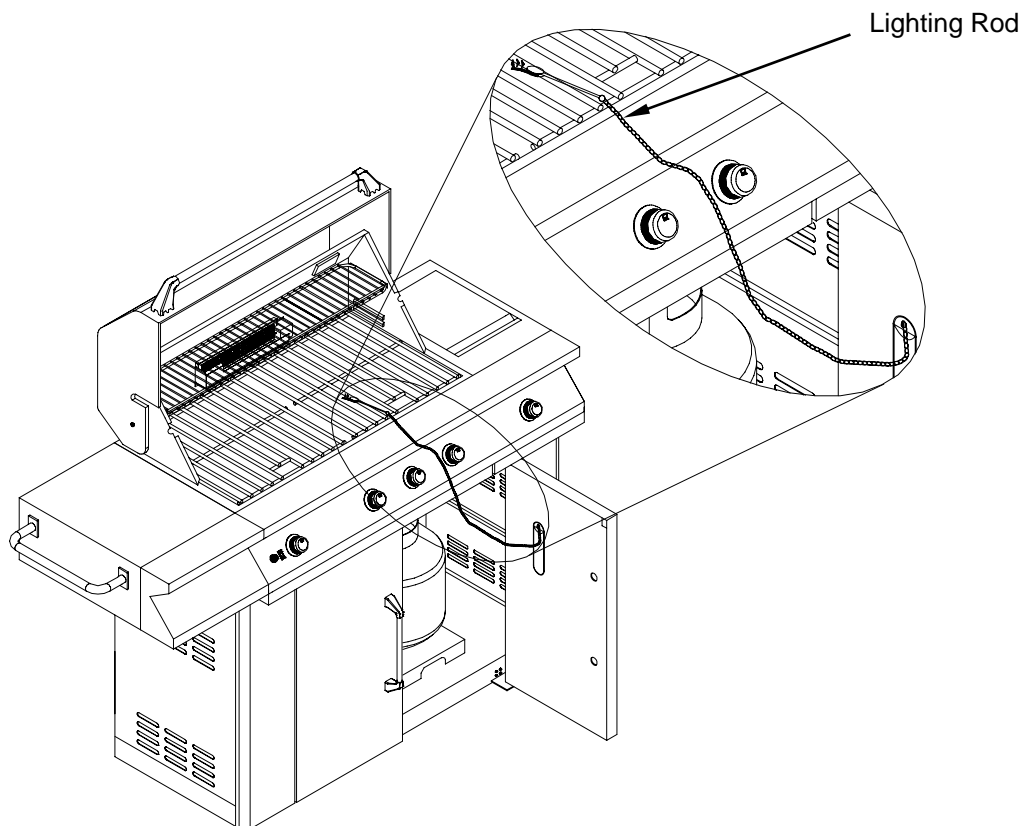

Sear Burner

1. If you have already attempted to light the searing side burner with the igniter, allow 5 minutes for any accumulated gas to dissipate.
2. Insert a match into the lighting rod. Ignite the match and insert through the cooking grid to the burner.
3. Press the control knob and rotate left to the "IGNITE/HI" setting, continue to press the knob until the burner ignites. The burner should light immediately.
4. If the burner does not light within 4 seconds turn the knob to the "OFF" position, wait 5 minutes and try again.

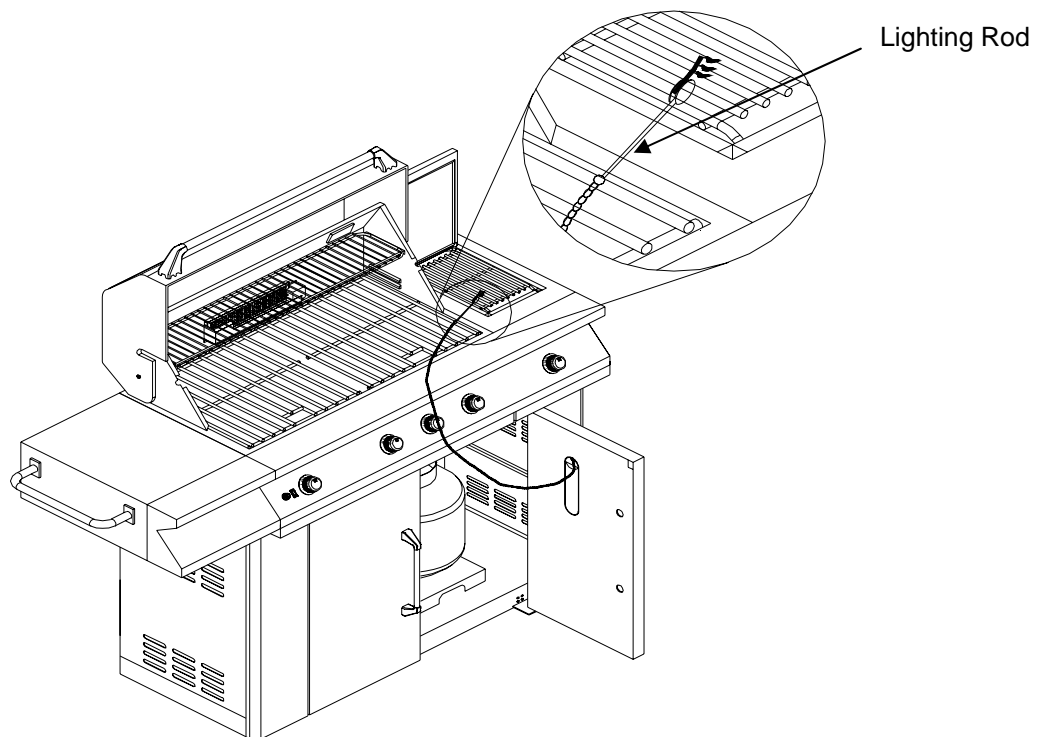

Rotisserie Burner

Note: Remove the warming rack when using a match to light the rotisserie burner.

1. If you have already attempted to light the rotisserie burner with the igniter, allow 5 minutes for any accumulated gas to dissipate.
2. Insert a match into the lighting rod. Ignite the match and place near the rotisserie burner.
3. Press the control knob and rotate left to the "IGNITE/HI" setting, continue to press the knob until the burner ignites. The burner should light immediately.
4. If the burner does not light within 4 seconds turn the knob to the "OFF" position, wait 5 minutes and try again.

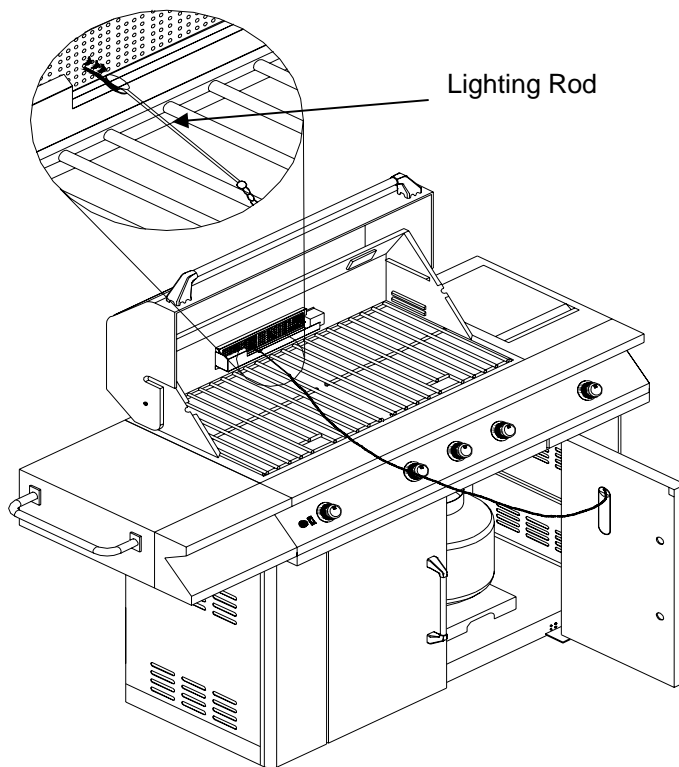

GRILL LIGHTS

Light Operation Instruction

1. Make sure light's power switch on the control panel is in the "OFF" position.
2. Connect power plug to properly grounded outlet.
3. Turn the light's power switch to "ON".



WARNING

Keep any electrical supply cord away from any heated surface.



Bulb Replacement

1. Make sure the light's power switch on the control panel is in the "OFF" position and power plug is disconnected from outlet.
2. Use a screwdriver to loosen the screw securing the light.
3. Take out the light
4. Remove the glass cover from the light compartment.



5. Use a screwdriver to loosen the two screws locking the bulb. Pull out the light bulb and replace with a new bulb.



6. Reverse the instruction from steps 5-1 for installation.



Cleaning Method

Follow steps 1-4 above for glass cover removal. Use a damp towel to clean the surface of glass cover. Make sure the glass cover is completely dry before re-installing.



WARNING

Make sure the light switch is on "OFF" position and power plug is disconnected from power outlet prior to cleaning the glass cover.



WARNING

The light glass cover should not be in contact with water or any other liquid when it's warm. Sudden change of temperature may cause cracks on glass cover.

Bulb Specification

Bulb Type: Halogen

Wattage: 10 watts per bulb

Voltage: 12 volts

Please contact customer service at 1-800-554-5799 for assistance on bulb replacement information.



WARNING

To ensure continued protection against electric shock:

1. Connect to properly grounded outlets only.
2. Do not expose to rain.
3. Keep extension cord connections dry and off the ground.

USING THE SIDE BURNER

Inspect the gas supply hose prior to turning on the gas. If there is evidence of cuts, wear or abrasion, it must be replaced prior to use. Do not use the side burner if gas odor is present.



WARNING

When lighting, always keep your face and body as far away from the burner as possible.

LIGHTING INSTRUCTIONS

1. Open the top cover or lid. Remove any cooking utensils that are near the burner grate.
2. Turn the control knob counterclockwise to the "HI" setting and then push the control knob in. You should hear a "clicking" sound if the electronic ignition system is working properly.
3. If the burner does not light within 4 seconds, turn the control knob to the "OFF" position.

4. If the smell of gas is detected and the igniter is not functioning, immediately turn the control knob to the "OFF" position.
5. Allow 5 minutes for any accumulated gas to dissipate. If the side burner igniter will not function, follow the match lighting instructions below.

MATCH LIGHTING

1. Insert a match into the lighting rod. Ignite the match and place near the side burner ports.
2. Turn the control knob counterclockwise to the "HI" setting. The side burner should light immediately.
3. Rotate the control knob to the desired setting.

CARE & MAINTENANCE OF SIDE BURNER

BURNER CLEANING

Clean the exterior of the burner with a wire brush. Clear any clogged burner ports with a straightened paper clip. Never enlarge the burner ports. Never use a wooden toothpick as it may break off and clog the port.

SIDE BURNER GRATE

The top burner grate is stainless steel. To avoid burns, do not clean the grates while they are hot. While in place, they may be washed with hot, soapy water, rinsed and wiped dry. Never immerse hot grates in water.

STAINLESS STEEL

There are many stainless steel cleaners available. Always use the mildest cleaning procedure first, scrubbing in the direction of the grain. Do not use steel wool as it will scratch the surface.

To touch up noticeable scratches in the stainless steel, sand very lightly with dry 100 grit sand paper in the direction of the grain.

CARE & MAINTENANCE OF THE GRILL

STAINLESS STEEL

Grease specks can gather and bake onto the surfaces of the stainless steel, giving the appearance of rust. For removal, use an abrasive pad with a stainless steel cleaner.

GRILL RACK

The best time to clean the grill is immediately after cooking is completed, and the flames have been turned off.

Wear a barbecue mitt to protect your hand from heat and steam.

Scrub the hot grill by dipping a bristle barbecue brush in tap water. Cleaning will be more difficult if the grill is allowed to cool.

CAUTION

Before cleaning, make sure the gas supply and control knobs are in the "OFF" position and the burners have cooled.

GRILL BURNER CLEANING

1. Turn off the gas supply, and make sure the control knobs are in the "OFF" position.
2. Make certain the grill is cool, and clean the exterior of the burner with a wire brush. Use a metal scraper for stubborn stains.
3. Clear clogged ports with a straightened paper clip. Never use a wooden toothpick. It may break off and clog the port.
4. Check and clean burners/venturi tubes for insects and insect nest. A clogged tube can lead to a fire beneath the grill.
5. If insects or other obstructions are blocking the flow of gas to the burner, call customer service at 1-800-554-5799.

CAUTION

1. Keep outdoor cooking gas appliance area clear and free from combustible materials, gasoline and other flammable vapors and liquids.
2. Do not obstruct the flow of combustible and ventilation air.
3. Keep the ventilation openings of the cylinder enclosure free and clear from debris.

GRILL BURNERS

Extreme care should be taken when moving a burner. It must be correctly centered on the orifice before any attempt is made to relight the grill. Frequency of cleaning will depend on how often you use the grill.

WARNING

Failure to properly place the burner over the orifice could cause a fire to occur behind and beneath the valve panel, thereby damaging the grill and making it unsafe to operate.

GRILL BURNER REMOVAL/INSTALLATION

The grill burners are factory installed.

To remove the main burners for cleaning:

1. Locate the nut at the rear of the burner on the bottom side.
2. Remove the nut and lift the burner out of the fire box.

To reinstall the main burners:

3. Insert the burner over the valve assembly (Item# 20 on page 24).
4. Insert the back of the burner into the hole at the rear of the fire box and reinstall the nut.
5. Make sure orifice spud is inside the burner's venturi as shown below.

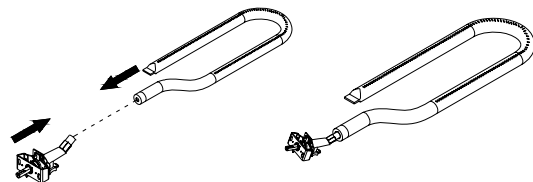

GREASE TRAY CLEANING

The grease tray should be emptied, wiped down and washed after each use with a mild detergent and warm water solution.

A small amount of sand or cat litter may be placed in the bottom of the grease tray to absorb the grease. Check the grease tray frequently. Do not allow excess grease to accumulate and flow out of the grease tray.

FLAME CHARACTERISTICS

Refer to "Flame Characteristics" on page 14.

TROUBLESHOOTING



WARNING

Spiders and insects can nest inside the burners of the grill and disrupt gas flow. This very dangerous condition could cause a fire behind the valve panel, thereby damaging the grill and making it unsafe for operation.

Inspect the grill at least twice a year.

WHEN TO LOOK FOR SPIDERS

You should inspect the burners at least twice a year or immediately after any of the following conditions occur:

1. The smell of gas in conjunction with burner flames appearing yellow.
2. The grill does not reach temperature.
3. The grill heats unevenly.
4. The burners make popping noises.

BEFORE CALLING FOR SERVICE

If the grill does not function properly, use the following checklist before contacting your dealer for service. You may save yourself the cost of a service call.

PROBLEMS

Grill will not light when the control knob is rotated.

WHAT TO DO

- Check to see if the liquid propane cylinder is empty.
- Clean wire(s) and/or electrode with rubbing alcohol and a clean swab. Wipe with a dry cloth.
- Make sure the wire is connected to the electrode assembly.
- Check to see if the other burners operate. If so, check the gas orifice on the malfunctioning burner for an obstruction.
- Replace the battery.

Burner flame is yellow or orange in conjunction with gas odor.

- Call customer service at 1-800-554-5799.

Low heat with the control knob on the "HI" setting.

- Check to see if the fuel hose is bent or kinked.
- Make sure the grill area is clear of dust.
- Check your gas regulator and pressure.
- Make sure the burner and orifice are clean.

EXPLODED VIEW 720---0511

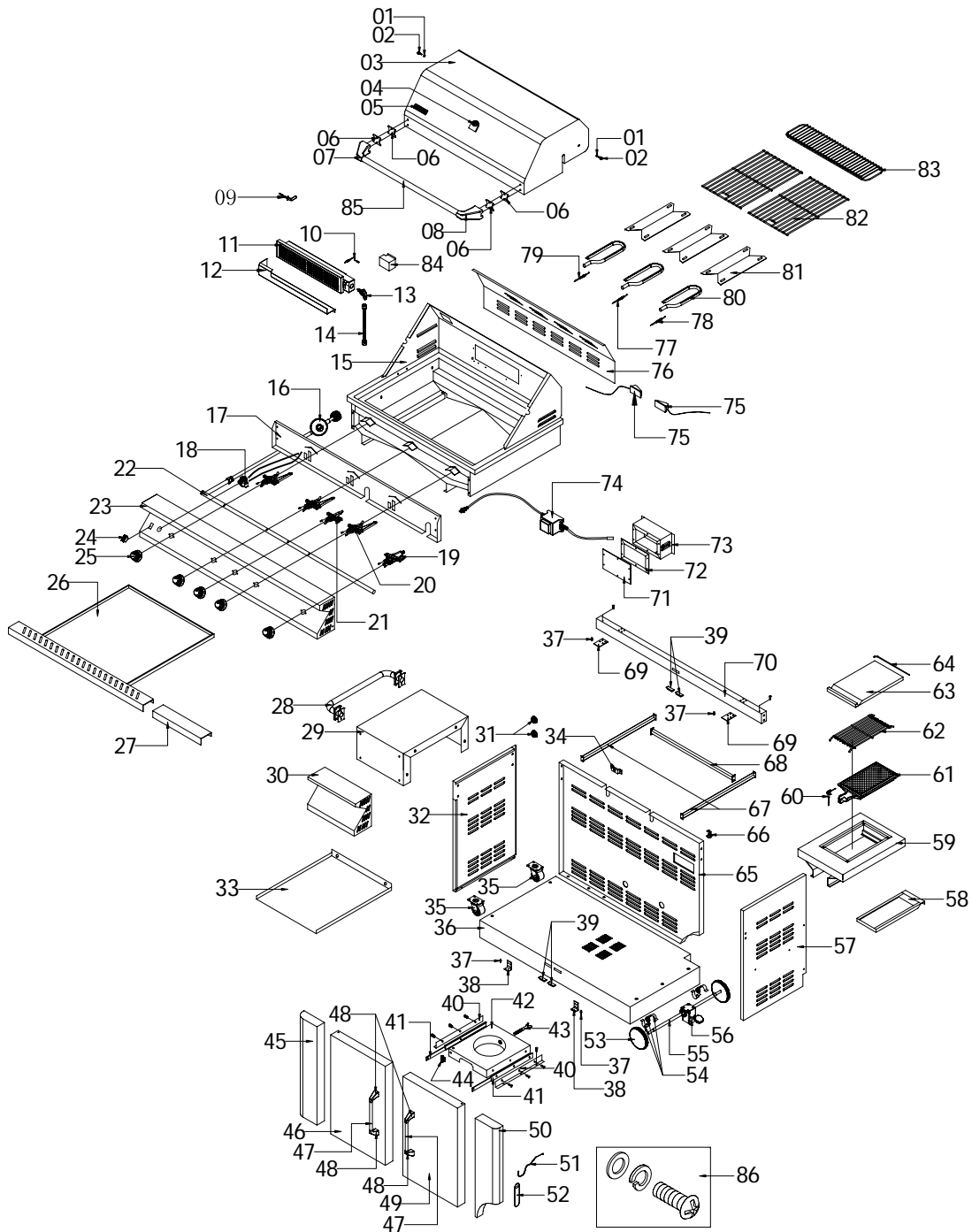

PARTS LIST 720-0511

REF#	DESCRIPTION	QTY	REF#	DESCRIPTION	QTY
01	Main lid screw Cover	2	37	Door Hinge	4
02	Main lid screw	2	38	Door Hinge Bracket, Bottom	2
03	Main Lid	1	39	Door Magnet	4
04	Temperature Gauge	1	40	Tank Tray Slide Bracket	2
05	Logo	1	41	Tank Tray Slide	2
06	Main Lid Handle Heat Insulating Spacer	4	42	Tank Tray	1
07	Main Lid Handle Seat, Left	1	43	Tank Bolt	1
08	Main Lid Handle Seat, Right	1	44	Gas Tank Tray Button	1
09	Rotisserie Burner Igniter wire	1	45	Front Trim Panel, Left	1
10	Thermocouple (Rotisserie Burner)	1	46	Front Door, Left	1
11	Rotisserie Burner	1	47	Door Handle Tube	2
12	Rotisserie Burner Gas Collector	1	48	Door Handle Seat	4
13	Rotisserie Orifice W/Brass Elbow	1	49	Front Door, Right	1
14	Rotisserie Burner Flex Gas Line	1	50	Front Trim Panel, Right	1
15	Main Burner Bowl Assembly	1	51	Lighting Rod	1
16	Regulator, LP	1	52	Lighting Rod, Cover	1
17	Front Baffle	1	53	Wheel	2
18	Electronic Igniter Module	1	54	Axletree Base	2
19	Sear Gas Valve	1	55	Wheel Axle	1
20	Main Gas Valve	3	56	Foot Brake	1
21	Rotisserie Gas Valve	1	57	Side Panel, Right	1
22	Main Manifold	1	58	Side Burner Grease Tray	1
23	Main Control Panel	1	59	Side Burner Bowl Assembly Frame	1
24	Light Switch	1	60	Sear Burner Igniter Wire	1
25	Control Knob	5	61	Sear Burner	1
26	Grease Tray	1	62	Sear Burner Cooking Grid	1
27	Grease Tray Extension Trim Piece	1	63	Side Burner Lid	1
28	Side Shelf Push Bar, Left	1	64	Side Burner Lid Hinge rod	1
29	Side Shelf, Left	1	65	Back Panel	1
30	Side Shelf Front Panel, Left	1	66	Cable Strainer	1
31	Rubber Grummet	2	67	Vertical Bar Barrier	2
32	Side Panel, Left	1	68	Horizontal Bar Barrier	1
33	Tank Heat Shield	1	69	Door Hinge Bracket, Top	2
34	Lamps fix bracket	1	70	Cart Frame , Front	1
35	Swivel Caster	2	71	Transformer Supporting Box Cover	1
36	Bottom Panel, LP	1	72	Transformer Box Waterproof Spacer	1

	DESCRIPTION	QTY	REF#	DESCRIPTION	QTY
73	Transformer Supporting Box	1	80	Main Burner	3
74	Transformer	1	81	Flame Tamer	3
75	Lamps	2	82	Cooking Grid With Hole	2
76	Rear Baffle	1	83	Warming Rack	1
77	Main Burner Igniter Wire (A)	1	84	Thermocouple Bracket (Rotisserie Burner)	1
78	Main Burner Igniter Wire (B)	1	85	Main Lid Handle Tube	1
79	Main Burner Igniter Wire (C)	1	86	Hardware	1

GRILLING HINTS

This Jenn-Air grill has an infrared side burner – commonly referred to as a “searing” burner. This type of burner produces extreme heat that can be used to “sear” the outside of food thus locking the juices inside. This process is used at many upscale restaurants to improve the flavor of the food. To properly use, cook each side of the meat for 1-2 minutes on the searing side burner and then move the meat to the main cooking surface to finish cooking the inside to your choice.

The preparation of meat, whether rare, medium, or well done, is affected to a large degree by the thickness of the cut.

The cooking time is affected by the type of meat, the size and shape of the cut, the temperature of the meat when cooking begins, and the degree of preparation desired.

It is recommended that meat be defrosted overnight in the refrigerator as opposed to a microwave. This generally yields a juicier cut of meat.

Use a spatula instead of tongs or a fork to turn the meat. A spatula will not puncture the meat and let the juices run out.

To get the juiciest meat, add seasoning or salt after cooking is finished and turn the meat only once during cooking. Juices are lost when the meat is turned several times. Turn the meat just after the juices begin to bubble to the surface.

Trim excess fat from the meat before cooking. To prevent steaks or chops from curling during cooking, slit the fat around the edges at 2 inch intervals.

 **WARNING**
Do not leave the grill unattended while cooking.

GRILL COOKING CHART

FOOD	WEIGHT OR THICKNESS	FLAME SIZE	APPROXIMATE TIME	SPECIAL INSTRUCTIONS AND TIPS
VEGETABLES				Slice. Dot with butter or margarine. Wrap in heavy-duty foil. Grill, turning occasionally.
Fresh Beets Carrots Turnips		Medium	12 to 20 minutes	Grill, turning once. Brush occasionally with melted butter or margarine.
Onion	1/2 inch slices	Medium	8 to 20 minutes	Season with Italian dressing, butter, or margarine.
Potatoes Sweet	Whole	Medium	40 to 60 minutes	Wrap individually in heavy-duty foil. Grill, rotating occasionally.
White	6 to 8 ounces	High	45 to 60 minutes	
Frozen Asparagus Peas Green beans Sprouts Broccoli Brussels		Medium	15 to 30 minutes	Dot with butter or margarine. Wrap in heavy-duty foil. Grill, turning occasionally.

French fries		Medium	15 to 30 minutes	Place in aluminum foil pan. Grill, stirring occasionally.
FOOD	WEIGHT OR THICKNESS	FLAME SIZE	APPROXIMATE TIME	SPECIAL INSTRUCTIONS AND TIPS
MEATS BEEF				
Hamburgers	1/2 to 3/4 inch	Medium	10 to 18 minutes	Grill, turning once when juices rise to the surface. Do not leave hamburgers unattended. A flare-up could occur quickly.
Tenderloin, Porterhouse, Rib eye		High	8 to 15 minutes	
Rare	1 inch	High	8 to 14 minutes	Remove excess fat from edges. Slash remaining fat at 2-inch intervals. Grill, turning once.
Medium	1-1/2 inch	High	11 to 18 minutes	
	1 inch	Medium to High	12 to 22 minutes	
Well-done	1-1/2 inch	High	16 to 27 minutes	
	1 inch	Medium	18 to 30 minutes	
Lamb Chops & Steaks Rare	1-1/2 inches	Medium	16 to 35 minutes	Remove excess fat from edges. Slash remaining fat at 2 inch intervals. Grill, turning once.
	1 inch	Medium	18 to 30 minutes	
Medium	1 inch	High	10 to 15 minutes	
	1-1/2 inch	High	14 to 18 minutes	
Well-done	1 inch	Medium to High	13 to 20 minutes	
	1-1/2 inch	High	18 to 25 minutes	
Well-done	1 inch	Medium	17 to 30 minutes	
Pork Chops	1 inch	Medium	20 to 30 minutes	Remove excess fat from edges. Slash remaining fat at 2 inch intervals. Grill, turning once. Cook well done.
Well-done	1-1/2 inches	Medium	30 to 40 minutes	
Ribs Pork		Medium	30 to 40 minutes	Grill, turning occasionally. During last few minutes, brush with barbecue sauce, turning several times.
Ham steaks (precooked)	1/2 inch slices	High	4 to 8 minutes	Remove excess fat from edges. Slash remaining fat at 2 inch intervals. Grill, turning once.
Hot dogs		Medium	5 to 10 minutes	Slit skin. Grill, turning once.

POULTRY Broiler/fryer	2 to 3 pounds	Low	1 to 1-1/2 hours	Place skin side up. Grill. Turn and brush frequently with melted butter, margarine, oil, or marinade.
FOOD	WEIGHT OR THICKNESS	FLAME SIZE	APPROXIMATE TIME	SPECIAL INSTRUCTIONS AND TIPS
Breasts well-done		Medium	30 to 45 minutes	Marinate with Italian dressing
FISH AND SEAFOOD				
Steaks Halibut Salmon Swordfish	3/4 to 1 inch	Medium to High	8 to 15 minutes	Grill, turning once. Brush with melted butter, margarine or oil to keep moist.
Whole Catfish	4 to 8 ounces	Medium to	12 to 20 minutes	Grill turning once. Brush with melted butter, margarine or oil.
Rainbow trout		High		Brush with melted butter and lemon juice.

GRILL RECIPES

BBQ SALMON

2 large salmon steaks
2 tbs. oil
Salt & pepper
2 oz. thin bacon slices
2 tbs. butter
1 tbs. lemon juice
Sprig of parsley
Lemon wedges

*You can substitute catfish, halibut or cod for salmon.

Preheat the BBQ

Brush the steaks with oil and season with salt and pepper. Place on BBQ grill and cook for 10 minutes, turning steaks over halfway through cooking time.

Meanwhile fry the bacon in a pan on the side burner. Drain on paper towels. Melt the butter in a small saucepan taking care not to discolor it. Arrange the fish and bacon on serving plates. Pour the butter over and sprinkle with lemon juice. Garnish with parsley sprigs and lemon wedges. Serve with boiled potatoes in butter and sprinkled with parsley.

BAKED CHILI CORN

6 medium ears corn, husked
3 tbs. butter or margarine, melted
Dash ground cumin
Dash ground coriander

About 1/2 hour before cooking, turn the grill on for butter. Place each ear on a heavy-duty foil. In a bowl, combine remaining ingredients. Mix well. Brush 1-1/2 tsp. butter mixture over each ear. Close foil and fold up ends to seal. Place on grill. Cook, turning packets occasionally 10 to 12 minutes or until cooked through.

TANGY SEAFOOD KABOBS

1 lb. large shrimp, shelled & deveined
3/4 lbs. Sea scallops
2/3 c. chili sauce
1/4 c. cider vinegar
3 tbs. Chopped parsley
1 tbs. Vegetable oil
1 tbs. Worcestershire sauce
1/2 tsp. Prepared horseradish
1 clove garlic, minced
1 20 oz. Can pineapple chunks in juice drained.

In medium bowl, combine shrimp and scallops. In small bowl, combine chili sauce and next six ingredients. Pour over seafood. Toss to coat. Cover, refrigerate 2 hours.

Half-hour before cooking, turn the burner to the grill on high. Drain seafood-reserving marinade. On each of twelve 10 in. skewers, thread 2 shrimp and 2 scallops, alternating with pineapple chunks. Place skewers on grill. Cook 7-10 minutes, basting and turning often.

PORK CHOPS

4 pork chops
Marinade
1 large onion
2 tbs. lemon juice or vinegar
2 tbs. oil
1/2 tsp. freshly ground black pepper
1 tsp. sugar
1/2 tsp. paprika
1 clove garlic
Peel, grate onion, and add rest of the ingredients except the pork chops. Mix well. Pour over chops and marinate one hour in a cool place. Turn the BBQ grill on high. Heat 10 minutes. BBQ the chops brushing with the marinade occasionally. Serve with mixed salad, dressed with vinaigrette flavored with fresh dill.

BARBECUED POTATOES and CHEESE

1 -1/2 cups shredded cheddar cheese
1 can (10-3/4 oz.) condensed cream of mushroom soup
1/3 cup milk
2 tbs. barbecue sauce
1/4 tsp. oregano
1/4 tsp. salt
1/8 tsp. pepper
4 cups thinly sliced potatoes (4 medium-sized potatoes)

Preheat grill. Combine cheese, condensed soup, milk, BBQ sauce, oregano, salt and pepper in a large mixing bowl. Stir in potatoes until well coated. Turn into well-buttered 1-1/2 quart rectangular baking dish. Cover dish with aluminum foil. Bake covered 25 minutes on medium with the lid of your BBQ grill closed. Remove foil and continue baking 15 minutes longer or until potatoes are tender. Let stand 5 minutes before serving.

BARBECUED LONDON BROIL

4 to 6 servings
3/4 c. Italian dressing

1 tsp. Worcestershire sauce
1 tsp. Dry mustard
1/4 tsp. Thyme, crushed
1 medium onion, sliced
1 pound flank steak, scoured
2 tbs. Butter, melted

Combine first 4 ingredients, add onion and marinade flank steak with it. Refrigerate at least 4 hours or overnight. Remove steak and grill on preheated BBQ grill. Grill 5 to 7 minutes on each side basting frequently with the marinade. In the meantime sauté onions from the marinade in butter in a skillet on grill side burner for 3 minutes. To serve, slice steak diagonally into thin slices, sprinkle onions over top. Garnish with vegetable kabobs.

VEGETABLE KABOBS

3 medium-size zucchini
12 cherry tomatoes
12 fresh mushrooms
Grated parmesan cheese

Parboil whole zucchini 5 minutes on grill side burner or until just tender. Drain and cut into 1/2 inch slices. Thread zucchini, tomatoes and mushrooms alternately on each of six skewers. Brush with marinade made of Italian dressing, Worcestershire sauce, mustard and thyme. Grill 5 to 7 minutes turning and basting occasionally. Sprinkle liberally with Parmesan cheese.

FAJITAS

1-1/2 lb. flank steak or boned chicken breasts
2 tbs. oil
1/2 cup lime juice
1/2 tsp. salt
1/2 tsp. celery salt
1/4 tsp. garlic powder
1/2 tsp. pepper
1/4 tsp. oregano
1/4 tsp. cumin
Flour tortillas
Lemon

Pound flank steak to 1/4 inch thickness or flatten chicken breasts. Mix oil, lime juice and seasonings in a zip lock bag. Add meat and shake bag to coat the meat. Refrigerate overnight or at least 6 to 8 hours. Wrap tortillas in foil. Remove meat from marinade. Cook on a pre-heated gas grill for 5 to 8 minutes on each side. While meat is cooking,

heat tortillas on grill. Slice meat across grain in thin slices. Place on hot platter. Squeeze lemon juice over. Wrap meat and any of the following toppings in tortillas: chopped tomatoes, guacamole, sour cream, and taco sauce.

BEEF AND LAMB KABOBS

Serve 4

1/2 lb. boneless sirloin or beef cut into 1 in. cubes
1/2 lb. boneless loin of lamb cut into 1 in. cubes
2/3 c. water, divided
1/4 c. chopped onion
2 tbs. soy sauce
1/4 c. vegetable oil, divided
1 tbs. dark brown sugar
1 tbs. fresh lemon juice
2 cloves garlic, minced
1/4 tsp. ground cumin
1/4 tsp. ground coriander
1/4 tsp. ground turmeric
1/8 tsp. ground red pepper
1/8 tsp. ground ginger
1 red pepper cut into chunks
1 large banana, cut into chunks
8 small mushrooms
1/3 c. smooth peanut butter

In blender, process 1/3 c. water, onion, soy sauce, 2 tsp. oil and the next 8 ingredients until smooth. Pour over meat cubes and marinate about 4 hours, turning occasionally. Drain and reserve marinade. Onto four 12 in. skewers alternately thread meat, pepper, banana and mushrooms. Preheat grill. Brush the kabobs with oil. Grill 7-8 minutes each side.

Bring marinade to boil on the side burner in a saucepan. Add remaining 1/3 c. water and peanut butter. Stir to blend. Heat through. If sauce gets too thick, add 1 tbs. water. Serve sauce with kabobs.

EGGPLANT CAVIAR

1 large eggplant
2 tbs. olive oil
2 tbs. wine vinegar
2 tbs. finely chopped onion
1/2 clove garlic, minced
1 medium tomato, chopped salt and pepper

Roast eggplant on gas grill over medium flame, turning occasionally until thoroughly cooked. This may take 30 minutes. Remove from grill and cool for handling. Strip off the skin and chop eggplant finely. Add all the seasonings. Chill thoroughly and serve on toast.

CHICKEN TANDOORI STYLE

8 large chicken thighs or drumsticks
1 c. plain nonfat yogurt
1/2 c. lemon juice
2 tsp. salt
1/2 tsp. cayenne
1/2 tsp. black pepper
1/2 tsp. crushed garlic
1/2 tsp. grated ginger
1 tbs. corn oil

Combine all the ingredients in a large mixing bowl and marinate the chicken for 8 hours in the refrigerator. Drain the chicken and spread on the spit running the rod on the fleshier side of the bone.

Bake using the rotisserie. Cook on medium high heat for 40 minutes basting occasionally with the remainder of the marinade mixture. Serve with sliced onions and lemon wedges.

SPARE RIBS

Marinade:
1 c. soy sauce
1/2 c. honey
1/2 c. vinegar
1/2 c. dry sherry
2 tsp. chopped garlic
2 tsp. sugar
1 c. water
1 chicken bouillon cube
1 can beer for basting sauce

Marinate ribs for 3 hours. Use marinade for basting by adding beer to it. Place pan under the ribs and baste frequently. To cook ribs select lean, meaty ribs and accordion pleat them with your spit. Slide four-prong meat hook down the length of spit and tighten. At the beginning of the rack and to its center, penetrate the second rib with the pointed end of the spit and push it between the meat. Skip a couple and continue the process until the entire rack is accordion pleated. Fasten the second meat hook into the rack. Turn rotisserie burner on high. Bake using the rotisserie for 50 minutes or until done.

PORK ROAST

Apple cider vinegar basting sauce:
1 c. apple cider vinegar
6 oz. water
1/2 stick butter
Salt, pepper, parsley and garlic seasoning

2 oz. lemon juice
10 lbs. pork roast

Time: 1-1/2 hours to 2 hours
Bring pork to room temperature before placing it on the rotisserie spit rod. Place on the rod and test for balance. Light rotisseries burner. Turn control knob to high. Use the above basting sauce for rotisserie baking

TURKEY

12 lb. turkey
Beer basting sauce:
1 can beer
12 oz. water
1 stick butter
1 tsp. salt
1 tsp. pepper
1/2 tsp. garlic flakes
1 tsp. parsley

Thaw the bird completely. Wash inside out. Securely tie the legs and wings before placing the turkey on the rotisserie spit rod. Light rotisseries burner. Turn to high. Combine all the ingredients for basting sauce in a shallow pan. Place it under the turkey 15 to 20 minutes. Cook for approximately 3 hours. The basting sauce combined with turkey drippings makes delicious gravy.

LIMITED WARRANTY

MODEL #720-0511

STAINLESS STEEL OUTDOOR GAS GRILL

Nexgrill Industries, Inc., warrants to the original consumer-purchaser of each Jenn-Air Outdoor Gas Grill that when subject to normal residential use, it is free from defects in workmanship and materials for the periods specified below. This warranty excludes grills used in rental or commercial applications.

Component	Warranty Period:
Stainless Steel Burners:	Lifetime
Stainless Steel Flame Tamer:	Lifetime
Stainless Steel Cooking Grids:	Lifetime
Valves and Hose Regulator:	1 Year
Igniter and Related Parts:	1 Year
All Stainless Steel Parts:	Lifetime

Our obligation under this warranty is limited to repair or replacement, at our option, of the product during the warranty period. The extent of any liability of Nexgrill Industries, Inc., under this warranty is limited to repair or replacement. This warranty does not cover normal wear of parts, discoloration of the stainless steel parts, or damage resulting from any of the following: negligent use or misuse of the product, improper use of the fuel/gas supply, use contrary to the operating instructions, or alteration by any person other than our factory service center. The warranty period is not extended by such repair or replacement.

Product repair as provided under this warranty is your exclusive remedy. Nexgrill Industries, Inc., shall not be liable for any incidental or consequential damages for breach of any express or implied warranty on its products. Except to the extent prohibited by applicable law, any implied warranty of merchantability or fitness for a particular purpose on this product is limited to the duration of the above warranty. Some states do not allow the exclusion or limitation of incidental or consequential damages, or allow limitations on how long an implied warranty lasts, so the above limitations or exclusions may not apply to you. This warranty gives you specific legal rights, and you may have other rights, which vary from state to state.

WARRANTY CLAIM PROCEDURE

If you require service or parts for your grill, please contact our Warranty Service Center for factory direct assistance. Our hours of operation are 7 AM to 6 PM PST Monday to Friday, 8 AM to 12 PM PST on Saturday. Our telephone number is 1-800-554-5799, fax number 1-800-598-8829. Please direct all correspondence to: Nexgrill Industries, Inc., 280 Machlin Court, City of Industry, California, 91789, ATTN: Warranty Service Center.

*Jenn-Air is a trademark of the Maytag Corporation and is used under license to Lowe's Companies, Inc.

Printed in China

Free Manuals Download Website

<http://myh66.com>

<http://usermanuals.us>

<http://www.somanuals.com>

<http://www.4manuals.cc>

<http://www.manual-lib.com>

<http://www.404manual.com>

<http://www.luxmanual.com>

<http://aubethermostatmanual.com>

Golf course search by state

<http://golfingnear.com>

Email search by domain

<http://emailbydomain.com>

Auto manuals search

<http://auto.somanuals.com>

TV manuals search

<http://tv.somanuals.com>