

# Fortra™



## **Force<sup>4</sup> G15 & G15+ RAID Systems** **15-bay Rackmount and Tower Enclosures**

### **Installation Guide**

May 31, 2002 • Revision A

Patent Pending

# JMR

Force<sup>4</sup>



#### Copyright

Copyright ©2000, 2001 by JMR Electronics, Inc. All Rights Reserved. No part of this publication may be reproduced, transmitted, transcribed, stored in a retrieval system, or translated into any language, in any form or by any means, electronic, mechanical, photocopying, recording or otherwise, without the express written permission of JMR Electronics, Inc.

#### Sales and Ordering Information

JMR Electronics, Inc.  
20400 Plummer Street  
Chatsworth, CA 91311 USA  
Phone: 818-993-4801  
Fax: 818-993-9173  
Office Hours: Monday-Friday 8:00 A.M. to 5:00 P.M., Pacific Standard Time

#### European Corporate Headquarters

JMR Electronics United Kingdom  
Iain Pickthall  
P.O. Box 3058 Wokingham  
Berkshire - RG40 3FU - United Kingdom  
Phone: + 44-118-973-6018  
Fax: + 44-118-973-7191  
E-Mail: Iain@jmr.com

Internet: <http://www.jmr.com>

#### Trademarks

JMR, the JMR logo, and **FORTRA**® are registered trademarks of JMR Electronics, Inc. All other product and brand names are the property of their respective holders.

#### Changes

The material in this document is for information only and is subject to change without notice. JMR Electronics, Inc. reserves the right to make changes to this manual and the equipment described herein without notice. JMR has made all reasonable efforts to ensure that the information in this manual is accurate and complete. However, JMR shall not be liable for any technical or editorial errors or omissions made herein or for incidental, special, or consequential damage of whatsoever nature resulting from the furnishing of this manual, or operation and performance of equipment with this manual.

#### Disclaimer

The original product packaging has been tested and is safe under normal shipping circumstances. Reshipping the product without using the original product packaging will void the warranty. Do not ship the unit with canisters or power supplies installed as this will void the warranty and could cause damage to the unit and drives. The canisters should be packaged separately within the product packaging as provided.

#### FCC Information

The **FORTRA**® equipment generates, uses and can radiate radio frequency energy. If the **FORTRA**® Array is not installed and used properly (that is, in strict compliance with these instructions), it may cause interference to radio and television reception.

The **FORTRA**® equipment and its contents are designed to comply with the limits for a Class A computing device in accordance with the specifications in Part 15 of FCC rules. These rules are designed to provide reasonable protection against radio interference in a commercial installation. However, there is no guarantee that interference will not occur in a particular installation. Operation of this equipment in a residential area is likely to cause interference, in which case the user, at his own expense, will be required to take whatever measures are necessary to correct the interference.

**WARNING:** Changes or modifications, not expressly approved by the manufacturer, could void the user's authority to use the equipment.

**WARNUNG:** Nicht ausdrücklich durch den Hersteller genehmigte Änderungen oder Modifikationen können die Erlaubnis Zur benutzung der Produkte gefährden.

You may find the FCC booklet, How to Identify and Resolve Radio Interference Problems, helpful. This booklet is available from the U.S. Government Printing Office, Washington, DC 20402. Stock #004-000-00345-4.

Printed in the USA  
Part Number PUB-00281  
Revision A, May, 2002 SCS  
Patent Pending

FORCE<sup>4</sup>



## Table of Contents

### 1. Introduction

<b>FORTRA®</b> Product Family Features .....	1-1
<b>FORTRA® Force<sup>4</sup></b> G15 RAID System Components .....	1-2
<b>FORTRA® Force<sup>4</sup></b> G15+ RAID System Components .....	1-2
Rackmount Specifications .....	1-2
Tower Specifications .....	1-3
Fibre Channel Features .....	1-3
Loop Expansion .....	1-3
Loop Bypass and Clock Timing Circuit .....	1-3
SFP CONNECTOR .....	1-3
Dual Loops (A & B) .....	1-3
ID Selection .....	1-4
SES .....	1-4

### 2. Hardware Specification

Environmental Specifications .....	2-1
Electrical Specifications .....	2-1
Agency Compliance .....	2-1
Packaging Specifications .....	2-1
Disclaimer .....	2-2
Thermal Specifications .....	2-2
Rotation Vibration Specifications .....	2-2
Fault Indication Features .....	2-2
Fault Indicators .....	2-2
Audible Alert .....	2-2
SYS-FLT .....	2-3

### 3. Device Installation

SCA Connection and Hot-Swapping .....	3-1
Canister Removal/Insertion .....	3-1
Drive Installation .....	3-2

### 4. Fibre Channel JBOD Setup

Slot Settings .....	4-1
Setting ID .....	4-2
1G Option Setting .....	4-3
ID Conflict .....	4-3



Option Settings .....	4-4
Delayed Start Option Jumper .....	4-4
Remote Start Option Jumper .....	4-4
Front Status LEDs .....	4-4
External I/O Connection .....	4-5
CH-A and CH-B (Top) .....	4-5
CH-A and CH-B (Bottom) .....	4-5
System/SES Fault LED & Audible Alert .....	4-5
Mute .....	4-6
SYS Activity LED .....	4-6
Loop Expansion (daisy chaining) .....	4-6
SES .....	4-6
<b>5. Blower Operation</b>	
Blower Removal/Insertion .....	5-1
Blower Replacement .....	5-2
<b>6. Power Supply Operation</b>	
Power Supply Removal/Insertion .....	6-1
Low Power Mode (Standby Power) .....	6-2
Power Supply Replacement .....	6-2
<b>7. FR15 Cabinet Installation</b>	
Rail Mounting Kit Hardware .....	7-2
Spare Hardware Parts .....	7-2
Rail Installation .....	7-2
<b>8. SES Operation</b>	
<b>9. Installing the Intel PCI RAID Controller</b>	
Installing the PCI Controller .....	9-1
Configuring RAID Sets .....	9-1
<b>10. Product Support</b>	
US Corporate Headquarters .....	10-1
Manual Changes .....	10-1
<b>Appendix A. Drive and Controller Manufacturers</b>	
Drive Manufacturers .....	A-1
RAID Controller Manufacturers .....	A-1
Host Bus Adapter Manufacturers .....	A-2

# 1. Introduction

The **FORTRA® Force<sup>4</sup>** G15 & G15+ RAID Systems are prepackaged 2G Fibre to 2G Fibre RAID solutions designed to be used with the included Intel PCI Dual 2G Fibre Channel host controller to provide a high-end RAID system solution. The following is a summary of the **FORTRA® Force<sup>4</sup>** G15 & G15+ RAID Systems features:

- The **FORTRA® Force<sup>4</sup>** G15 RAID Systems Tower enclosure supports up to fifteen 3.5" LP SCA 40-pin SCA drives. This 2G Fibre Channel enclosure has dual ports (A & B) and has additional connections on each port for loop expansion. The G15 RAID System comes with the Intel PCI Dual 2G Fibre Channel RAID Controller.
- The **FORTRA® Force<sup>4</sup>** G15 & G15+ RAID System Rackmount enclosures are 19" wide, 3U (5-1/4") high rackmount enclosures that supports up to fifteen 3.5" LP SCA 40-pin SCA drives. All other features are the same as the **FORTRA® Force<sup>4</sup>** G15 RAID System Tower.

## FORTRA® Product Family Features

**FORTRA®** and **StorBlade™** are families of high-end RAID Systems enclosures. The following table shows the features of the **FORTRA®** and **StorBlade™** products:

	2-bay	4-bay <sup>1,3</sup>	6-bay <sup>1,3</sup>	8-bay <sup>1</sup>	10-bay <sup>1,2</sup>	12-bay	15-bay <sup>1,3</sup>	StorBlade
Number of Device Bays	2	4	6	8	10	12	15	4
Number of Blowers	1	1	1 or 2	2	2	2	2	2
Number of Power Supplies	1	1	1 or 2	2	2	2	2	1 or 2
Number of I/O Channels (SCSI Only)	1	1	2	2	2		2	2
SCSI SE/LVD Supported	✓	✓	✓	✓	✓		✓	✓
Fibre Channel Supported		✓	✓	✓	✓		✓	✓
Hot-Swap Canisters	✓	✓	✓	✓	✓	✓	✓	✓
Removable Power Supplies	✓	✓	✓	✓	✓	✓	✓	Fibre only
Removable Blowers	✓	✓	✓	✓	✓	✓	✓	Fibre Only
N+1 Power Supplies			✓	✓	✓	✓	✓	Fibre only
N+1 Blowers			✓	✓	✓	✓	✓	✓
MIA Support (FC Only)		✓	✓	✓	✓			
Loop Expansion Support (FC Only)		✓	✓	✓	✓		✓	✓
Daisy Chainable (SCSI Only)	✓	✓	✓	✓	✓			✓
Built-in Termination (SCSI Only)			✓	✓	✓		✓	
Auto Termination (SCSI Only)			✓	✓	✓		✓	
SAF-TE/SES Ready (Optional)			✓	✓	✓		✓	Fibre only
SAF-TE/SES Compatible			✓	✓	✓		✓	Fibre only
SCSI to SCSI RAID Support				✓	✓		✓	✓
Fibre to SCSI RAID Support					✓		✓	
Fibre to Fibre RAID Support					✓		✓	✓
Fibre to ATA RAID Support						✓		
SCSI to ATA RAID Support						✓		
(D)esktop/(T)ower/(R)ackmount	D	D	DTR	T	TR	R	TR	R
* 6/10/15-bay unit features apply to both Tower and Rackmount models								
1 Features are based on a standard configuration with no internal host controller(s) installed								
2 Fibre channel 10/15-bay enclosures have built-in SES								
3 Fibre Channel 2Gb Model available. 2Gb models use SFP transceivers.								



**FORTRA® Force<sup>4</sup>** products use advanced mid-plane technology developed by JMR, which allows power supplies, drives, and all other enclosure components to interface into a single board. This provides superior performance and easy connectivity.

The host interface supports a SFP (Small Formfactor Plug) Fibre Channel transceiver at 2Gb/s.

All **FORTRA® Force<sup>4</sup>** G15 & G15+ RAID Systems Fibre enclosures have built-in SES on the personality card that allows control and monitoring of some enclosure components using SES commands through the host.

## **FORTRA® Force<sup>4</sup> G15 RAID System Components**

The **FORTRA® Force<sup>4</sup>** G15 RAID System contains the following components:

- One - Fortra® 15-bay Rackmount or Tower Enclosure
- One - Intel 2G PCI Fibre RAID Controller
- Fifteen - Seagate 73G HDDs
- Two - 2G Copper Fibre Cables (HSSDC to HSSDC2)

## **FORTRA® Force<sup>4</sup> G15+ RAID System Components**

The **FORTRA® Force<sup>4</sup>** G15+ RAID System contains the following components:

- Two - Fortra® 15-bay Rackmount Enclosures
- One - Intel 2G PCI Fibre RAID Controller
- Thirty - Seagate 36G or 73G HDDs
- Two - 2G Copper Fibre Cables (HSSDC to HSSDC2)

## **Rackmount Specifications**

### **Dimensions/Weight**

Unit Weight	40 lbs. (18.2kg)
Height	5-1/4" (3U) (133mm)
Width	19" (483mm)
Depth	23" (584mm)

### **Power Supply** (Each power supply includes internal cooling fan)

Quantity:	2
Power:	430 Watts each (N+1) Power Factor Correction
Input:	100-260 VAC; 50-60Hz
Output:	+5V @ 35A +12V @ 30A

### **Blower**

Quantity:	4 (2 per cannister)
Size:	97mm (3.82") each
Air Flow:	25.42CFM (0.72m <sup>3</sup> /min) each
Noise:	52dB(A)



## Tower Specifications

### Dimensions/Weight

Unit Weight	43 lbs. (19.5kg)
Height	20-1/2" (521mm)
Width	9-5/8" (235mm)
Depth	24" (610mm)

### Power Supply (Each power supply includes internal cooling fan)

Quantity:	2
Power:	430 Watts each (N+1) Power Factor Correction
Input:	100-260 VAC; 50-60Hz
Output:	+5V @ 35A +12V @ 30A

### Blower

Quantity:	4 (2 per cannister)
Size:	97mm (3.82") each
Air Flow:	25.42CFM (0.72m <sup>3</sup> /min) each
Noise:	52dB(A)

## Fibre Channel Features

### Loop Expansion

**FORTRA® Force<sup>4</sup>** G15 and G15+ 2Gb/s Fibre Channel enclosures include a loop expansion I/O connector on each port. This allows the connection to other Fibre Channel enclosures, switches, servers, hubs, and other Fibre devices.

### Loop Bypass and Clock Timing Circuit

Each port (A & B) includes a loop bypass circuit that monitors each slot for a loop connection. It has two modes of operation: NORMAL and BYPASS. In NORMAL mode, the device is connected to the loop. In BYPASS mode, the device is either absent or non-functional and data bypasses to the next available device until the correct device is located.

The unit also has a built-in clock recovery circuit that adjusts the timing for any input or output that is going through the enclosure.

### SFP CONNECTOR

The **FORTRA® Force<sup>4</sup>** G15 and G15+ 2Gb/s Fibre Channel enclosures use Small Formfactor Plugs (SFP) as the Fibre I/O ports.

### Dual Loops (A & B)

A single loop is required for unit operation however both loops can be used to connect to different hosts, dual host adapters, and other devices, for flexible and even redundant configurations. For specific connection and installation information, refer to [Chapter 4](#).



### **ID Selection**

0-127 device ID addresses are addressable and can be easily set-up via ID rotary switches located on the personality modules. For specific connection and installation information, refer to [Chapter 4](#).

### **SES**

**FORTRA® Force<sup>4</sup>** G15 and G15+ 2Gb/s fibre channel enclosures have a built-in SES processor on the personality card. See [Chapter 8](#) for SES information.

FORCE<sup>4</sup>



## 2. Hardware Specification

This chapter covers specification information for all FORTRA® **Force4** G15 Tower and G15+ Rackmount or Tower enclosures.

### Environmental Specifications

**Operating Temperature:** 5°C to 40°C (41°F to 104°F)

**Storage Temperature:** 0°C to 65°C (32°F to 149°F)

The maximum recommended ambient temperature depends on the recommendation of the manufacturer for the devices being installed.

### Electrical Specifications

**AC Inlet Type:** IEC320/EN60320

**Power Cord:** NEMA5-15P

**Power Supply:** Auto-switching for 110/220V operation

### Agency Compliance

FORTRA® **Force4** G15 and G15+ enclosures have been designed and built to comply with the FCC Class A, UL, CSA/TUV, CE, and C-Tick standards. For more information on FCC Class A compliances, see page 2.

### Packaging Specifications

FORTRA® **Force4** G15 and G15+ packaging has been designed to be reusable and recyclable. Drives may be installed and shipped in the canisters as long as the canisters are not installed in the enclosure. Shipping the unit with canisters and/or power supplies installed in the enclosure may cause damage to the enclosure or to the drives and will void the warranty.

Packaging complies with ISTA (International Safe Transit Association) standards and has been ISTA certified.

Each canister is pre-packaged in an anti-static bag. Do not throw the packaging away if the product is intended for re-shipping. When transporting or shipping a JMR approved shipping container must be used.

**SAFETY TIP:** *Reshipping the enclosure with canisters, drives, or power supplies installed in the enclosure may cause damage to these components and will void the warranty*

**SICHERHEITSHINWEIS:** *Der Versand des Gehäuses mit eingebauten Einschüben, Platten und Netzteilen kann zur Beschädigung dieser Komponenten führen und somit den Garantieanspruch gefährden.*

FORCE4



### **Disclaimer**

The original product packaging has been tested and is safe under normal shipping circumstances. Reshipping the product without using the original product packaging will void the warranty. Do not ship the unit with canisters and/or power supplies installed in the enclosure as this will void the warranty and could cause damage to the unit and drives. The canisters should be packaged separately within the product packaging, as provided.

### **Thermal Specifications**

**FORTRA® Force<sup>4</sup>** G15 and G15+ enclosures have been designed to meet the air-flow/cooling requirements for popular 7,200, 10,000, and 15,000 RPM disk drives. Using high performance blowers, air is pulled in from all open vents and exhausted out the back of the unit.

### **Rotation Vibration Specifications**

**FORTRA® Force<sup>4</sup>** G15 and G15+ enclosures have been designed to meet the rotation vibration/shock requirements for popular 7,200, 10,000, and 15,000 RPM disk drives.

### **Fault Indication Features**

This section reviews the indicators that will notify the user of a power supply or blower that is in a fault state. More information is available in Chapter 5 (blowers) and Chapter 6 (power supply).

**SAFETY TIP:** *Reshipping the enclosure with canisters, drives, or power supplies installed in the enclosure may cause damage to these components and will void the warranty*

**SICHERHEITSHINWEIS:** *Der Versand des Gehäuses mit eingebauten Einschüben, Platten und Netzteilen kann zur Beschädigung dieser Komponenten führen und somit den Garantieanspruch gefährden.*

### **Fault Indicators**

On a blower fault, all the front status LEDs will blink **'Red'**. The blower LED on the back of the unit will light red and an audible alert will sound.

On a power supply fault, all the front status LEDs will also blink **'Red'**. The power supply fault LED will light and an audible alert will sound. The audible alert can be turned off through SES.

### **Audible Alert**

There are three audible enclosure alerts that are controlled through the SES processor:

- Two beeps indicate a temperature issue.
- Three beeps indicate a blower failure;
- Five beeps indicate a power supply failure;



### **SYS-FLT**

The SYS-FLT LED on the back of the unit indicates an error on the SES bus. It also indicates whether an active loop connection is established. If no loop connections are established, the LED will light **Red**.

FORCE4

# 3. Device Installation

This chapter covers Fibre Channel device installation for both the **FORTRA® Force4** G15 and G15+ rackmount and tower enclosures.

## SCA Connection and Hot-Swapping

The unit uses SCA-2, 40-pin connectors which provide a safe means of connection/disconnection when hot-swapping devices. In order to hot-swap devices, the host adapter or RAID controller and host operating software must support the feature. Any SCA drive is capable of plugging directly into the backplane of the unit and should not require any additional cabling or connections.

## Canister Removal/Insertion

1. The photo to the right shows the canister in a locked position.

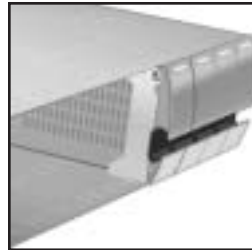

2. Pull the handle out to unlock the canister from the **FORTRA®** unit. Ensure that the thumb is placed below the line. Pressing the thumb against the Status LED lens could break it. Notice that the locking tab slides down as the handle is pulled out.

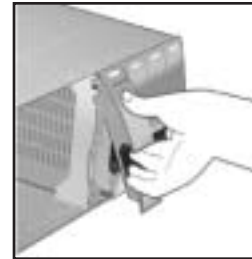

**SAFETY TIP:** After disengaging a device from the enclosure, allow 10 seconds before pulling the canister out of the unit. This allows the device to properly spin/shut down before transport.

**SICHERHEITSHINWEIS:** Nachdem ein Einschub vom Gehäuse wie in "Step 3" gezeigt gelöst wurde, warten Sie bitte ca. 10 Sekunden bevor der Einschub ganz heraus gezogen wird. Dies ermöglicht den Auslauf der Festplatte bis zum vollständigen Stillstand der rotierenden Scheiben für einen sicheren Transport.

3. Pull the canister straight out to remove. Ensure that any installed devices are spun down before full removal to prevent damage to the drive.



Follow the steps in reverse to reinstall.

## Drive Installation

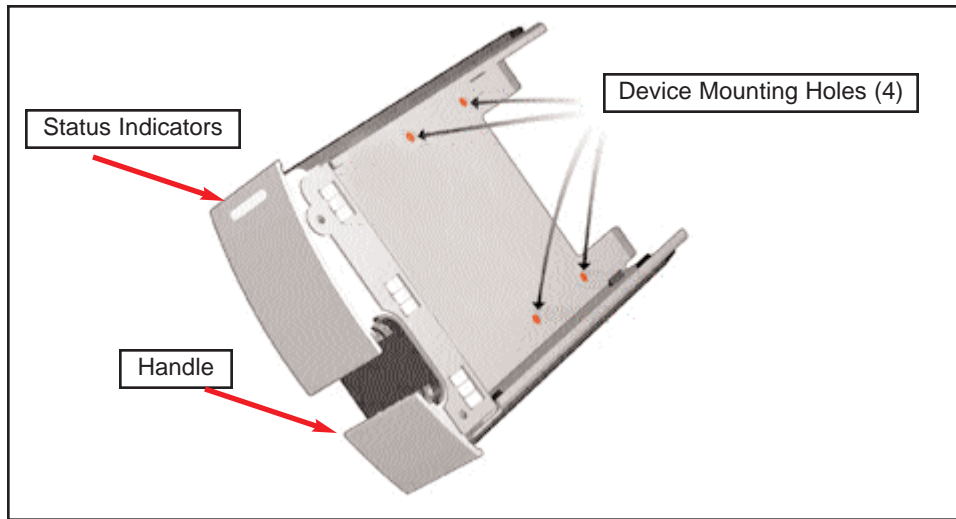

Device mounting screws are included with the unit for device mounting. The JMR part number for the #6-32" mounting screws is HDS-01906.

**WARNING:** Before device installation, alleviate any electro-static discharge by touching a grounded metal assembly. Static can be potentially damaging to enclosure components.

**WARNUNG:** Berühren Sie vor der Festplatteninstallation geerdete Metallgegenstände, um elektro statische Aufladung abzuleiten. Statische Aufladung kann elektronische Gehäusekomponenten schwer beschädigen.

**WARNING:** The #6-32 mounting screws that are provided have been specially designed to fit the canisters. Do not install the device using any other screws than the ones provided.

**WARNUNG:** Die mitgelieferten Befestigungsschrauben #6-32 wurden speziell für die Einschübe angefertigt und zur Befestigung der Festplatte sollten Sie keinesfalls andere als diese verwenden.

1. After removing the canister, place it on a static free surface along with the device to be installed.
2. Place the device in the canister and mount it using the provided screws (use 4 screws to mount the drive).
3. Replace the canister into the unit by following the steps for Removal of a Device Canister but in reverse order.



4. Repeat steps 1 through 3 until all devices are installed, then move onto step 5 to complete unit setup and installation.
5. Configure ID and other options as required. See [Chapter 4](#) for Fibre Channel device setup.
6. Install and configure SES and other optional features. See [Chapter 8](#).
7. For rackmount units, refer to [Chapter 7](#) to install the enclosure into a cabinet.
8. Establish host connection. See [Chapter 4](#) for Fibre Channel host connection.

## 4. Fibre Channel JBOD Setup

This chapter covers Fibre Channel device configuration and option settings. The **FORTRA® Force<sup>4</sup>** G15 and G15+ have built-in SES on the personality card. Refer to [Chapter 8](#) for SES operation. Please take note of the installation warnings below before beginning setup.

**WARNING:** Take care when connecting the unit to an AC power source to ensure that it is plugged-in to a circuit of the appropriate rating (110v or 220v). For safe operation, the circuit should have over-current protection to prevent damage to the unit in the event of circuit overloading.

**WARNUNG:** Vergewissern Sie sich, daß die Netzspannung (220V / 110V) korrekt eingestellt ist, bevor Sie das Gerät mit dem Stromnetz verbinden. Zur Sicherheit sollte das Netz über einen Überspannungsschutz zur Vermeidung von Schäden im Falle einer Überlast verfügen.

**WARNING:** When connecting the unit to an AC outlet or power strip, ensure that the outlet has the proper connection for grounding. The AC power cables included with the unit have three prongs, one of which is used for the ground connection. Do not use a two prong AC cable with the unit since this will not allow for proper unit grounding and could cause problems with normal unit operation.

**WARNUNG:** Bei der Verbindung der Unit mit einer Steckdose oder einer Verteilerdose sollten sie auf eine korrekte Erdung derselben achten. Die mitgelieferten Kaltgeräteanschlußkabel habe 3 Kontakte, von denen einer zur Erdung verwendet wird. Verwenden Sie kein Stromkabel mit 2 Anschlüssen, da dieses keine korrekte Erdung ermöglicht und Probleme während des regulären Betriebs verursachen kann.

### Slot Settings

The pictures to the right show the slot numbering sequence and the default ID settings. Default ID settings are based on both ID rotary switches set to a value of 0.

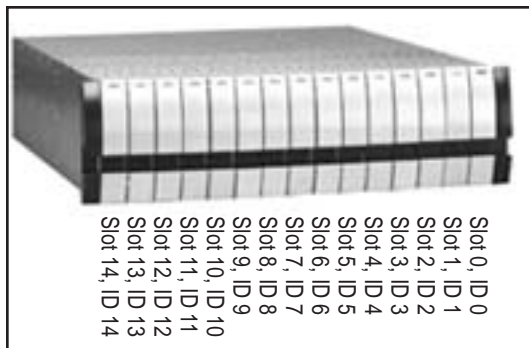

FORCE<sup>4</sup>

## Setting ID

Rotary switch settings only affect Slot 0 and all other slots are sequentially increased by a value of one after that slot.

The ID is set sequentially starting from a base address. The base address, or starting address, is set via a 0-7 position rotary switch located on the back of the unit. There is a second 0-15 position rotary switch which can be changed to modify the base address setting. Both the top and bottom switches must be set identically.

The default value for both switches is 0.

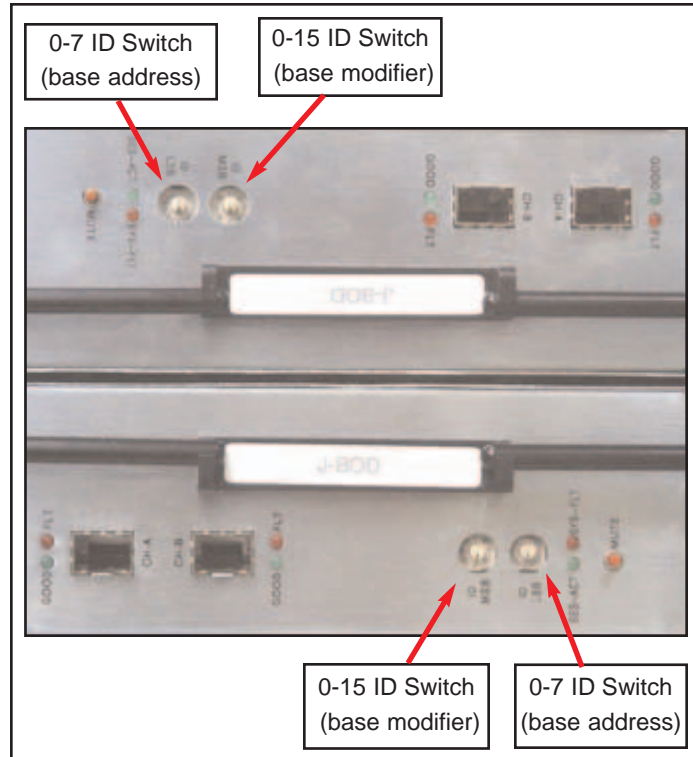

The 0-7 switch is used to set the base address which is multiplied by 16, and the 0-15 switch is used to set the offset modifier to the base address. The formula for setting the ID is:  $x(16)+y$ , where  $x$  is the 0-7 switch and  $y$  is the 0-15 switch.

**Example:** The 0-7 switch is set to 2, the 0-15 switch is set to 6. This sets the base address to 38 ( $2*16=32, +6=38$ ). So Slot 0 ID = 38, Slot 1 ID = 39, Slot 2 ID = 40, Slot 3 ID = 41, etc... up to Slot 14 ID = 52.

The table below provides the Slot 0 Starting (Base) Address Settings.



	0	1	2	3	4	5	6	7
0	0	16	32	48	64	80	96	112
1	1	17	33	49	65	81	97	113
2	2	18	34	50	66	82	98	114
3	3	19	35	51	67	83	99	115
4	4	20	36	52	68	84	100	116
5	5	21	37	53	69	85	101	117
6	6	22	38	54	70	86	102	118
7	7	23	39	55	71	87	103	119
8	8	24	40	56	72	88	104	120
9	9	25	41	57	73	89	105	121
10	10	26	42	58	74	90	106	122
11	11	27	43	59	75	91	107	123
12	12	28	44	60	76	92	108	124
13	13	29	45	61	77	93	109	125
14	14	30	46	62	78	94	110	126
15	15	31	47	63	79	95	111	127

### 1G Option Setting

By setting the rotary switch settings to “7” - “F”, the enclosure will operate in 1G mode. Both the upper set of switches and lower set of switches must be set to the same value. The drive ID’s will revert to the default value of 0-14 and can not be changed. Therefore, if daisy chaining to another enclosure, care must be taken not to use the same drive ID’s on the same loop.

### ID Conflict

When two devices share the same ID, a conflict occurs. This should not happen unless two or more enclosures are daisy chained together. If devices in one enclosure conflict with devices in another enclosure, the devices will re-arbitrate ID and resolve the conflict.

### Option Settings

Two option settings are located on the mid-plane board. To access the jumpers, the cover must be removed and the personality boards removed. The diagram below shows the location of the option settings on the mid-plane board.

FORCE4

**WARNING:** Before opening the cover, disconnect the AC power cord from both AC inlets to prevent injury.

**WARNUNG:** Vor dem Entfernen der Abdeckung sind beide 220V Netzkabel (Kaltgeräteanschlusskabel) zu entfernen, um Verletzungen zu vermeiden.

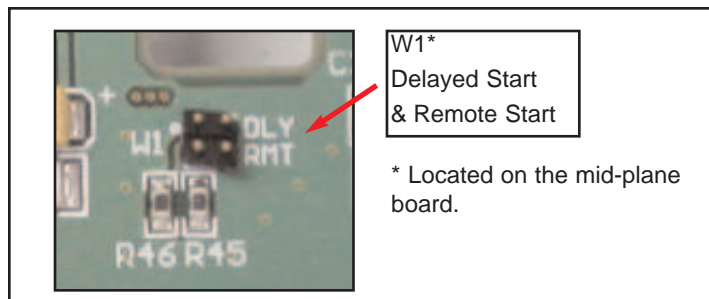

### Delayed Start Option Jumper

Header W1 pins 1 & 2.

Jumper on = enabled.

Jumper off = disabled (default).

### Remote Start Option Jumper

Header W1 pins 3 & 4.

Jumper on = enabled.

Jumper off = disabled (default).

### Front Status LEDs

A status indicator is located on each canister. A 'Blue' light indicates normal drive activity. A 'Red' light indicates a device fault. If all canisters display a 'Red' light that is blinking on and off it indicates that there is a system fault. A system fault is either a power supply or blower failure. Check the back of the unit to determine which fault has occurred. Refer to [Chapter 5](#) for blower fault indicator location and to [Chapter 6](#) for power supply fault indicator location.



## External I/O Connection

The external I/O connections are located on the personality card. There are four SFP transceiver connectors accessible from the rear of the unit.

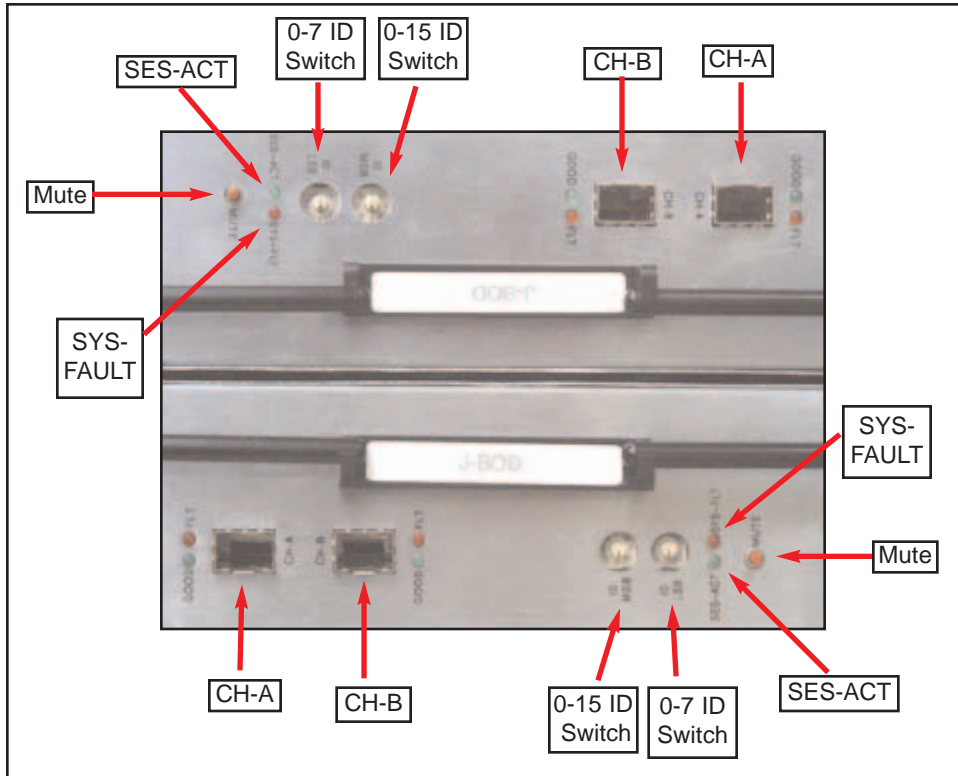

### **CH-A and CH-B (Top)**

Input and output connections for Loop 1. These are SFP (2Gb/s) transceiver connectors used to connect to a host system or to an expansion chassis.

### **CH-A and CH-B (Bottom)**

Input and output connections for Loop 2. These are SFP (2Gb/s) transceiver connectors used to connect to a host system or to an expansion chassis.

### **System/SES Fault LED & Audible Alert**

This red LED will light along with a buzzer if a system fault occurs. A system fault includes over temperature, power fault, or blower fault. The buzzer will sound off with a sequence of beeps to indicate the fault that has occurred.

- 2 beeps = Temperature Fault
- 3 beeps = Blower Fault
- 5 beeps = Power Supply Fault

The light will stay on red if a fault occurs. During normal operation, the red light will blink to notify that internal SES monitoring is working.

**Mute**

This is a push button used to silence the Audible Alarm.

**SYS Activity LED**

This is an LED for SES that will blink whenever there is activity between a host SES unit and the JMR SES processor

**Loop Expansion (daisy chaining)**

To connect two JMR enclosures together on the same bus, the OUT port of the first enclosure is connected to the IN port of the second enclosure.

**SES**

A built-in SES processor provides in-band bus management for the unit. Refer to [Chapter 8](#) for information about the SES processor.

FORCE4

# 5. Blower Operation

This chapter covers all operations of the blowers for **FORTRA® Force4** G15 and G15+ units. Refer to Chapter 1 for blower specifications. The blowers are hot swappable and can be removed or installed while the enclosure continues to function, however, failure to replace a non-working blower within a reasonable period of time may expose drives to extreme heat, which could cause loss of data.

**WARNING:** *Blowers are a system critical component. Non-operating blowers should be replaced as soon as possible to avoid data loss or device failure.*

**WARNUNG:** *Gebläse sind für die Funktion wichtige Komponenten. Nicht funktionierende Gebläse sollten so schnell wie möglich ersetzt werden, um Datenverluste oder Fehlfunktionen zu vermeiden.*

The blowers are located on the back of the unit and each has its own fault LED that will light if the blower is non-operational.

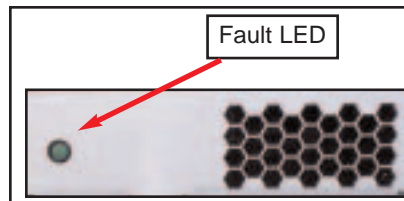

## Blower Removal/Insertion

The blower is designed to be easily installed and removed.

1. Unfasten the blower thumbscrew by turning counterclockwise. A Philips head screwdriver can be used if the thumbscrew is too tight to turn by hand.
2. Remove the blower sled by pulling out on the handle and grasping the side of the blower tray. Wait for the blower to stop completely before removing it from the unit.

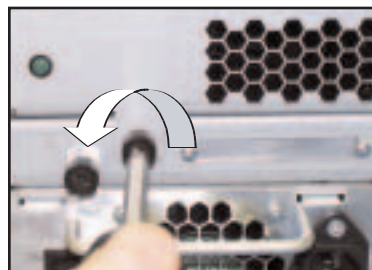

Reverse the steps to reinstall the blower.

**WARNING:** *To prevent injury when removing or installing the blower, do not grab the bottom of the tray which is used for blower access intake. The blower operates at high speeds and continues to spin for a short time after power is disconnected.*

**WARNUNG:** *Um Verletzungen während der Entfernung oder Installation des Gebläses zu vermeiden, berühren Sie nicht dessen Unterseite, da hier der Lufteintritt erfolgt. Das Gebläse arbeitet mit hohen Geschwindigkeiten und läuft nach Abschalten der Versorgungsspannung noch einige Zeit nach.*

**WARNING:** Avoid direct contact with the blower intake access hole while the blower is running. The blower operates at high speeds and can cause injury.

User's removing or installing a blower must be aware of the blower access hole. Contact with the access hole must be avoided while the blower is running to prevent injury.



## Blower Replacement

If the blower has stopped running or the fault LED indicator is lit, the blower may need to be replaced. Before replacing, the connection should be checked to ensure that the connector is firmly seated and that there is nothing blocking the blower blades that could cause interference.

If a blower is believed to be in a nonfunctional state, please contact the place of purchase for repair or replacement.

The JMR part number for a replacement blower is shown below. The assembly includes the tray along with the blower.

<b>Model</b>	<b>JMR Part Number</b>
15-bay	SBA-05207

# 6. Power Supply Operation

This chapter covers all operations of the power supplies. For operation, the AC cord (included) must be connected to the AC Inlet on each supply, and the power supply must be switched ON. The 'OK LED' will light to indicate the power supply is functioning properly. If the power supply experiences a problem and cannot operate within its normal specifications, the Fault LED will light and the power supply will shut itself off.

The power supplies also have their own fan included to maintain proper cooling within each supply and also provide some additional, but minimal airflow through the rest of the enclosure.

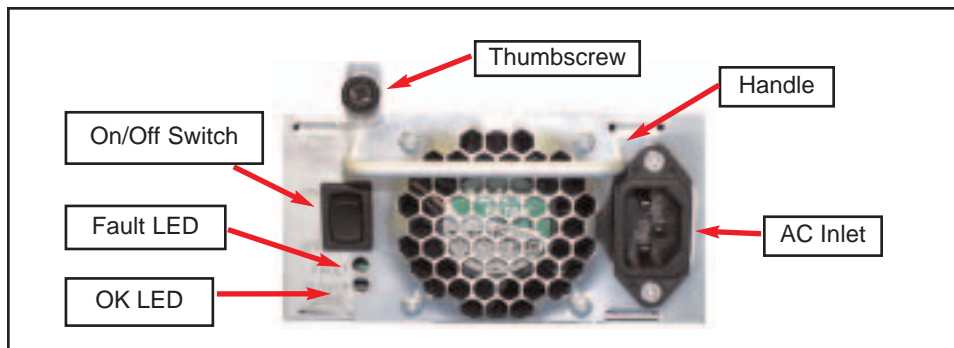

## Power Supply Removal/Insertion

Follow the following steps to either remove a power supply in a 10/15-bay unit.

1. Unfasten the power supply thumbscrew by turning counterclockwise. A Philips head screwdriver may be used if the thumbscrew is too tight to turn by hand.

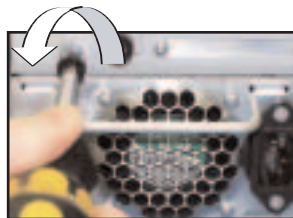

2. Remove by pulling out on the handle.



Reverse the steps to reinstall the power supply.



## Low Power Mode (Standby Power)

When both power supplies are turned off, the unit will switch to low power or standby mode and the power supply fans will continue to run. The unit blowers will remain operational if a single power supply is turned off, not installed, or fails, in order to maintain the proper low temperature within the unit. To stop the power supply fans and turn the unit off completely, it must be disconnected from the AC power source.

## Power Supply Replacement

If the Power Supply Fault LED indicator is lit, the power supply may need to be replaced. Before replacing, the power supply should be turned off, removed from the enclosure, and reinstalled. The AC cable connection should be checked to ensure that the connector is firmly seated and the power supply should be firmly inserted with the thumbscrew tightly securing it. If the Fault LED indicator is still coming on, then the power supply should be replaced.

If the fan in the power supply is not functioning but the power supply still works, the power supply unit should be replaced as soon as possible. Leaving the power supply running without the fan could cause the power supply to overheat and shutdown at any time.

If you believe a power supply is in a nonfunctional state, please contact the place of purchase for repair or replacement.

JMR part number for a replacement power supply is shown below. The assembly includes the power supply installed in the canister.

<b>Model</b>	<b>JMR Part Number</b>
15-bay PSS-00721	

**SAFETY TIP:** Both power supplies should be installed into the unit at all times to maintain proper cooling and airflow within the enclosure. In the event of a power supply failure, the faulty supply should be left in the enclosure until a replacement power supply is available.



## 7. FR15 Cabinet Installation

This chapter covers the installation of the Rackmount enclosure into a standard 19" (483mm) wide and 30" (762mm) to 36" (914mm) deep cabinet that meets the EMA/RETMA standards.

Before beginning rail installation, please take note of the following precautions:

**NOTE:** When installing the unit into a cabinet or closed environment, the operating ambient temperature of the rack environment may be greater than the maximum recommended ambient temperature. Consideration must be taken to meet the maximum recommended ambient temperature ( $T_{mra}$ ) for the best unit operation.

**HINWEIS:** Wenn das Gerät in einen Gehäuseschrank oder eine sonstige geschlossene Umgebung verbaut wird, kann die Umgebungstemperatur über die maximal zulässige Betriebstemperatur ansteigen. Maßnahmen bzgl. der maximalen, empfohlenen Betriebstemperatur ( $T_{mra}$ ) müssen getroffen werden, um eine bestmögliche Funktion des Gerätes zu gewährleisten.

**WARNING:** Ensure that the front and back of the unit are not blocked when installing the unit into a cabinet or closed area. Blocking the front or back of the unit can cause reduced air-flow that will compromise the safe operating environment within the unit.

**WARNUNG:** Vergewissern Sie sich, daß das Gerät an Vorder- und Rückseite nicht abgedeckt ist, wenn das Gerät in einem Gehäuseschrank oder einer geschlossenen Umgebung verbaut wird. Abdeckung der Vorder- und Rückseite kann verminderte Kühlung zur Folge haben und somit sichere Betriebsbedingungen negativ beeinflussen.

**WARNING:** When loading the unit into a cabinet, ensure that a hazardous condition is not achieved due to uneven mechanical loading. To prevent injury, remove the power supplies and drives before loading, and re-install them after the unit has been secured in the cabinet.

**WARNUNG:** Vermeiden Sie während des Einbaus des Gerätes in einen Gehäuseschrank jegliche gefährliche Aktionen, selbst wenn diese nur mechanischer Art sind. Um Verletzungen zu vermeiden, entfernen Sie die Netzteile und Laufwerke vor der Montage und installieren Sie diese erst erneut, wenn das Gerät im Gehäuseschrank gesichert ist. Vergewissern Sie sich, daß das Gerät an Vorder- und Rückseite nicht abgedeckt ist.

### Rail Mounting Kit Hardware

- Ten #10-32 Screws
- Four each #8-32 Screws/Washers/Nuts



### Spare Hardware Parts

Check with a JMR Sales Representative for pricing and availability of spare hardware parts.

Description	JMR Part Number
#10-32 Screw	HDS-01580
#8-32 Screw	HDS-00350
#8-32 Nut	HDN-00040
#8-32 Washer	HDW-00080

### Rail Installation

A completed rail assembly without the unit uninstalled would look like this:

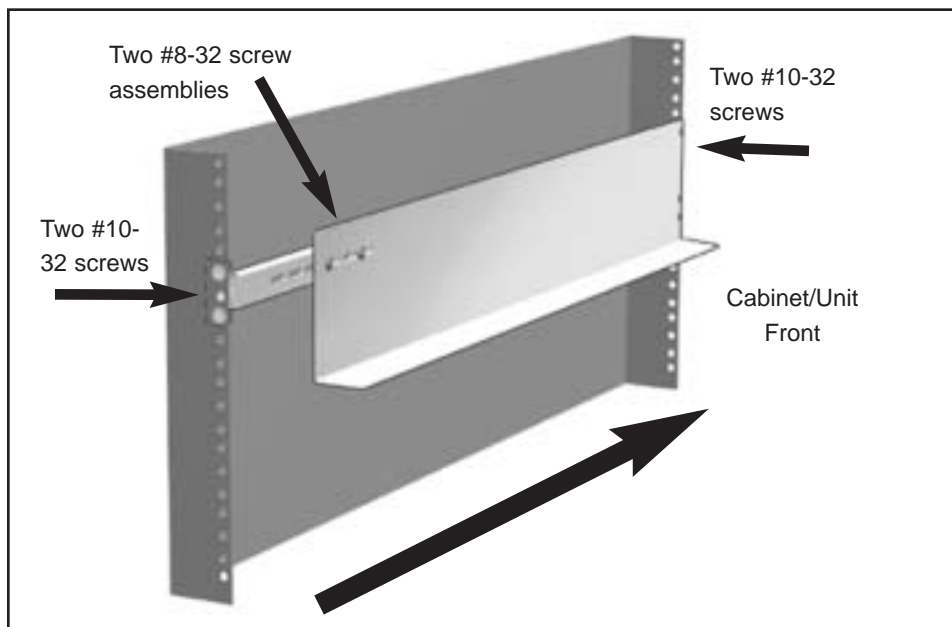

1. Affix the extension brackets to the main rail using the #8-32 screw/washer/nut assemblies. Adjust to the correct length for the cabinet depth being used.

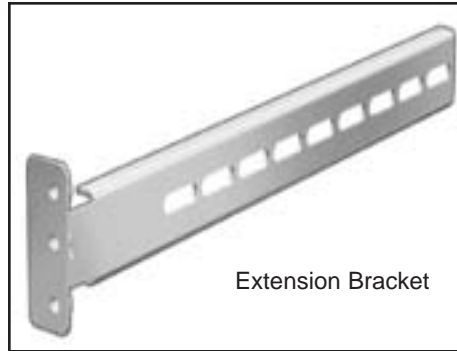
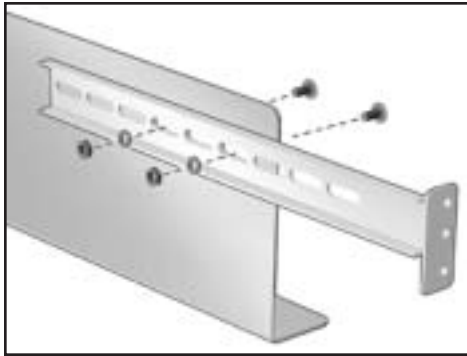

2. Affix the extension bracket to the rear of the unit using two #10-32 screws. There are 3 holes in the extension bracket for mounting. Depending on the hole pattern that is being used in the cabinet, two holes should always be available for securing the extension bracket.

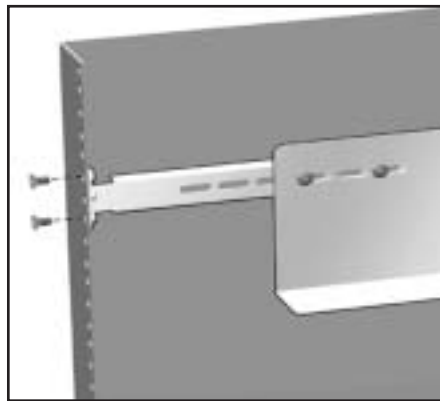

3. The fronts of the rails have three holes. Two of the holes (top and bottom) are used to secure the rail to the cabinet. The middle hole is used to secure the enclosure to the rail and cabinet. Secure the front of each rail to the cabinet vertical rails using two #10-32 screws for each rail.

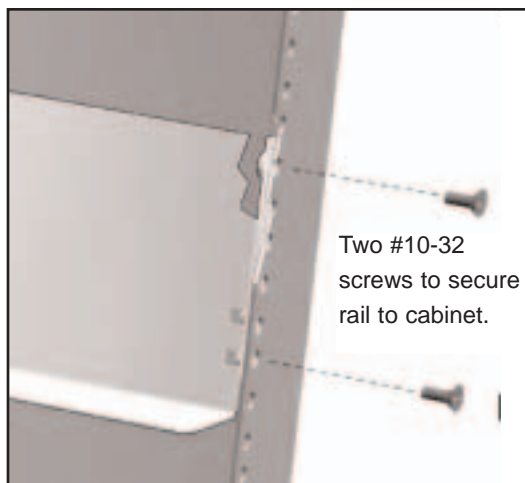

- Slide the unit into the cabinet and secure it to the cabinet with a single #10-32 screw on each side.

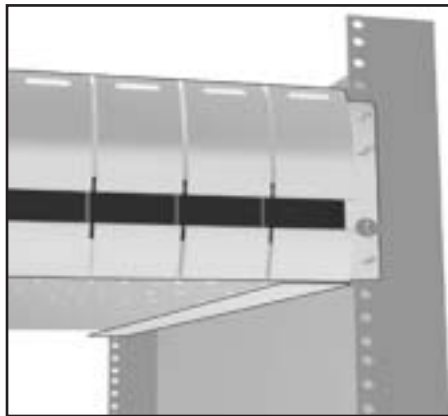
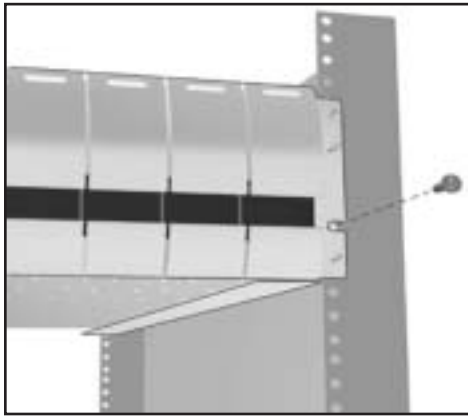

- Snap the end cap over the screw on each side of the unit to finish the installation.

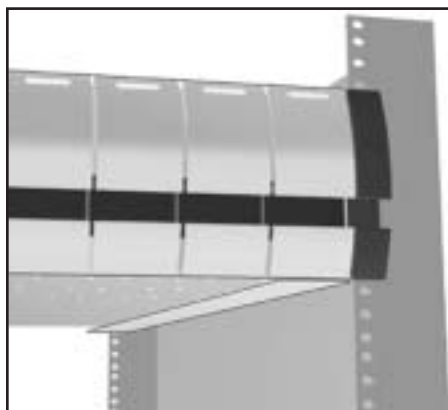
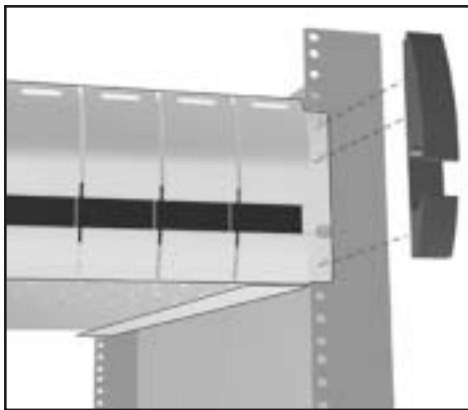

## 8. SES Operation

For bus management, the **FORTRA® Force<sup>4</sup>** G15 and G15+ 2G Fibre channel enclosures have a built-in SES processor designed to meet the SFF-8067 specification.

In order to communicate with the SES processor, at least one device must be present in the enclosure.

Force<sup>4</sup>

# 9. Installing the Intel PCI RAID Controller

This chapter covers the installation of the Intel PCI RAID Controller that is shipped with the **FORTRA® Force<sup>4</sup>** G15 and G15+ RAID Systems. The model number of the PCI RAID Controller is ICP Vortex number GDT8522RZ (ICP Vortex is a wholly owned subsidiary of Intel Corporation)

## Installing the PCI Controller

To install the PCI Controller, perform the following steps:

- 1) Switch off the PCI computer and disconnect all cables. Ensure that the power cord is removed first.
- 2) Following the instructions in the computer manual, open the case of the PCI computer, so that you have easy access to the PCI expansion slots.
- 3) Select a free 64 Bit PCI bus-master slot or 32 Bit PCI bus-master slot and remove the metal bracket, following the instructions in your PCI computer manual. It is essential that the ICP Controller is plugged into a bus-master slot (it will NOT work in a slave or non-busmaster slot).
- 4) Push the ICP Controller firmly into the correct PCI bus-master slot. Make sure that the controller fits tightly into it, and that the external connectors stick out of the computer case. Now, fix the ICP Controller by tightening the screw of its bracket.
- 5) Reconnect the PCI computer systems covers, cables and lastly the power cord.
- 6) Before powering up the PCI computer system, connect the Fibre Channel cable/cables to the G4 sub-system. The cable to be used should have a HSSDC connector at one end and a HSSDC2 connector at the other end.
- 7) The PCI computer system is now ready to be powered up.

## Configuring RAID Sets

To configure the RAID sets, refer to the ICP Vortex User Manual located on the CD shipped with the **FORTRA® Force<sup>4</sup>** G15 and G15+ RAID Systems.

# 10. Product Support

For current information on this product, including updates to the manual and technical support related issues, please contact the sales support section of our web page at [www.jmr.com](http://www.jmr.com), or you can contact our Technical Support division directly at the address below.

## US Corporate Headquarters

JMR Electronics, Inc.

ATTN: Technical Support Division

20400 Plummer St.

Chatsworth, CA 91311

Customer Support: (818) 739-1140

E-mail: [techsupport@jmr.com](mailto:techsupport@jmr.com)

Office Hours: Monday-Friday 8:00 A.M. to 5:00 P.M., Pacific Standard Time

Internet: <http://www.jmr.com>

## Manual Changes

Revision A - Initial Release

FORCE4

# Appendix A. DRIVE AND CONTROLLER MANUFACTURERS

## Drive Manufacturers

Fujitsu

Internet Address: [www.fcpa.com](http://www.fcpa.com)

Hitachi

Internet Address: [www.hitachi.com](http://www.hitachi.com)

IBM (International Business Machines Corporation)

Internet Address: [www.ibm.com](http://www.ibm.com)

Maxtor

Internet Address: [www.maxtor.com](http://www.maxtor.com)

Seagate Technology

Internet Address: [www.seagate.com](http://www.seagate.com)

## RAID Controller Manufacturers

Adaptec, Inc.

Internet Address: [www.adaptec.com](http://www.adaptec.com)

Chaparral Network Storage

Internet Address: [www.chaparralnet.com](http://www.chaparralnet.com)

Digi-Data Corporation

Internet Address: [www.digidata.com](http://www.digidata.com)

Infortrend Corporation

Internet Address: [www.infortrend.com](http://www.infortrend.com)

Intel ICP VORTEX (Intelligent Computer Peripherals)

Internet Address: [www.icp-vortex.com](http://www.icp-vortex.com)

Mylex Corporation

Internet Address: [www.mylex.com](http://www.mylex.com)

Silicon Image, CMD Storage Systems

Internet Address: [www.cmd.com](http://www.cmd.com)

FORCE<sup>4</sup>





## Host Bus Adapter Manufacturers

Adaptec, Inc.

Internet Address: [www.adaptec.com](http://www.adaptec.com)

Antares Microsystems

Internet Address: [www.atares.com](http://www.atares.com)

Emulex Corporation

Internet Address: [www.emulex.com](http://www.emulex.com)

JNI Corporation

Internet Address: [www.jni.com](http://www.jni.com)

QLogic Corp.

Internet Address: [www.qlogic.com](http://www.qlogic.com)

FORCE4

## Free Manuals Download Website

<http://myh66.com>

<http://usermanuals.us>

<http://www.somanuals.com>

<http://www.4manuals.cc>

<http://www.manual-lib.com>

<http://www.404manual.com>

<http://www.luxmanual.com>

<http://aubethermostatmanual.com>

Golf course search by state

<http://golfingnear.com>

Email search by domain

<http://emailbydomain.com>

Auto manuals search

<http://auto.somanuals.com>

TV manuals search

<http://tv.somanuals.com>