



DESIGNED TO MOVE [YOU]

# JRV210

MOBILE AUDIO SYSTEM

## Installation and Operation Manual

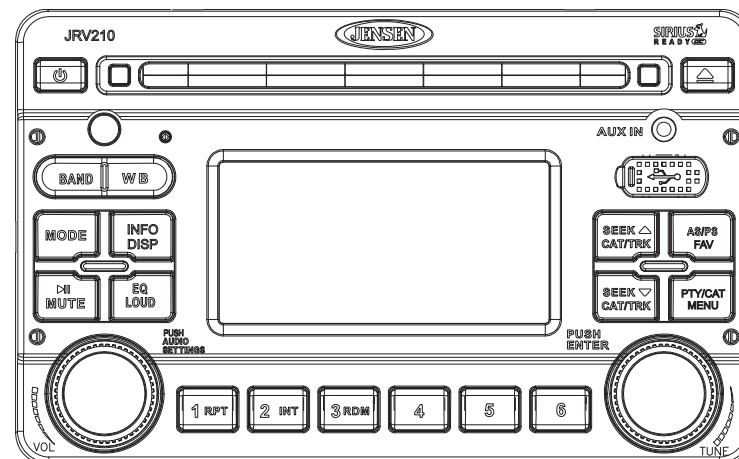

## **SAFETY INFORMATION**

### ***When Driving***

Keep the volume level low enough to be aware of the road and traffic conditions.

### ***Protect from Water***

Do not expose the product to water, as this can cause electrical shorts, fire or other damage.

### ***Protect from High Temperatures***

Exposure to direct sunlight for an extended period of time can produce very high temperatures inside your vehicle. Give the interior a chance to cool down before starting playback.

Do not mount radio within close proximity of engine compartment.

### ***Use the Proper Power Supply***

This product is designed to operate with a 12 volt DC negative ground battery system.

### ***Protect the Disc Mechanism***

Avoid inserting any foreign objects into the disc slot. Misuse may cause malfunction or permanent damage due to the precise mechanism of this unit.

### **CAUTION:**

THIS MOBILE CD PLAYER IS A CLASS I LASER PRODUCT. THIS UNIT USES A VISIBLE/ INVISIBLE LASER BEAM WHICH COULD CAUSE HAZARDOUS RADIATION IF EXPOSED DIRECTLY. BE SURE TO OPERATE THE MOBILE CD PLAYER AS INSTRUCTED.

USE OF CONTROLS OR ADJUSTMENTS OR PERFORMANCE OR PROCEDURES OTHER THAN THOSE SPECIFIED HEREIN MAY RESULT IN HAZARDOUS RADIATION EXPOSURE.

DO NOT OPEN COVERS AND DO NOT REPAIR BY YOURSELF. PLEASE REFER SERVICING TO A QUALIFIED TECHNICIAN.

### **WARNING:**

- TO REDUCE THE RISK OF FIRE OR ELECTRIC SHOCK, DO NOT EXPOSE THIS EQUIPMENT TO WATER.
- TO REDUCE THE RISK OF FIRE OR ELECTRIC SHOCK AND INTERFERENCE, USE ONLY THE RECOMMENDED ACCESSORIES.

## DISC NOTES

Depending on the recording status, conditions of the disc, and the equipment used for recording, some CD-Rs/CD-RWs may not play on this unit. For more reliable playback, please adhere to the following recommendations:

- Use CD-RWs with speed 1x to 4x and write with speed 1x to 2x.
- Use CD-Rs with speed 1x to 8x and write with speed 1x to 2x.
- Do not play a CD-RW which has been written more than 5 times.

### Compatible Disc Types

Table 1: General Disc Information

| Disc Type | Logo | Diameter/<br>Playable Sides | Playback Time |
|-----------|------|-----------------------------|---------------|
| Audio CD  |      | 12 cm single side           | 74 minutes    |

**NOTE: CD-R and CD-RW discs will not play unless the recording session is closed and the CD is finalized.**

### Disc Maintenance

- A dirty or defective disc may cause sound dropouts while playing. Before playing, wipe the disc using a clean cloth, working from the center hole towards the outside edge. Never use benzene, thinners, cleaning fluids, anti-static liquids or any other solvent.

|                                     |                            |   |   |
|-------------------------------------|----------------------------|---|---|
| <p><b>Insert label side up.</b></p> | <p><b>Do not bend.</b></p> | <p><b>Never touch the under side of the disc.</b></p> | <p><b>Wipe clean from the center to the edge.</b></p> |
|-------------------------------------|----------------------------|---|---|

- Be sure to use only round CDs for this unit and do not use any special shape CDs. Use of special shape CDs may cause the unit to malfunction.
- Do not stick paper or tape on the disc. Do not use CDs with labels or stickers attached or that have sticky residue from removed stickers.
- Do not expose discs to direct sunlight or heat sources such as hot air-ducts, or leave them in a vehicle parked in direct sunlight where there can be a considerable rise in temperature inside the vehicle.

**NOTE: A disc may become scratched (although not enough to make it unusable) depending on how you handle it and other conditions in the usage environment. These scratches are not an indication of a problem with the player.**

## INSTALLATION

### Before You Begin

- 1. Disconnect Battery**  
Before you begin, always disconnect the battery negative terminal.
- 2. Remove Transport Screws and discard.**

### Important Notes

- Before final installation, test the wiring connections to make sure the unit is connected properly and the system works.
- Use only the parts included with the unit to ensure proper installation. The use of unauthorized parts can cause malfunctions.
- Consult with your nearest dealer if installation requires the drilling of holes or other modifications to your vehicle.
- Install the unit where it does not interfere with driving and cannot injure passengers if there is a sudden or emergency stop.
- If the installation angle exceeds 30° from horizontal, the unit might not give optimum performance.
- Avoid installing the unit where it will be subject to high temperatures from direct sunlight, hot air, or from a heater, or where it would be subject to excessive dust, dirt or vibration.

### 2-DIN Front Mount

This unit can be installed in a dashboard with an opening of the following dimensions:

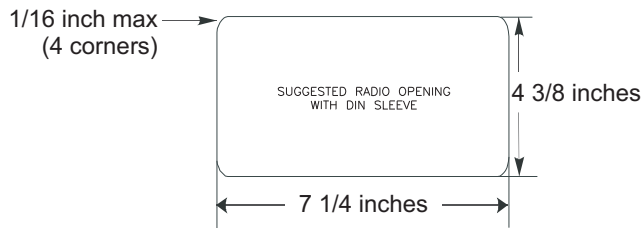

- 1.** Slide the mounting sleeve off of the chassis if it has not already been removed. If it is locked into position, use the removal keys (supplied) to disengage it. Insert the keys through the holes in the front panel as far as they will go, and then slide the sleeve off the back of the unit.

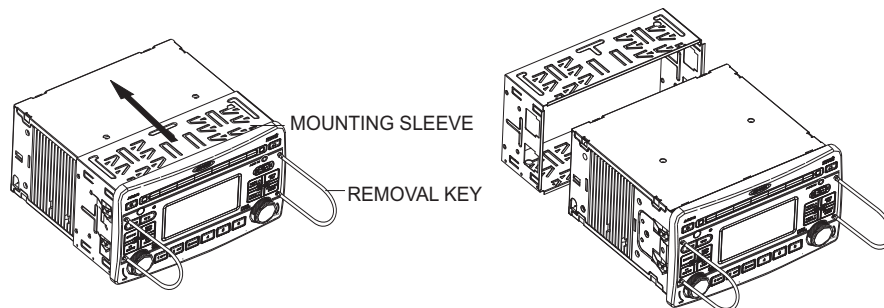

- 2.** Check the dashboard opening size by sliding the mounting sleeve into it. If the opening is not large enough, carefully cut or file as necessary until the sleeve easily slides into the opening. Do not force the sleeve into the opening or cause it to bend or bow. Check that there will be sufficient space behind the dashboard for the radio chassis.
- 3.** Locate the series of bend tabs along the top, bottom and sides of the mounting sleeve. With the sleeve fully inserted into the dashboard opening, bend as many of the tabs outward as necessary to firmly secure the sleeve to the dashboard.

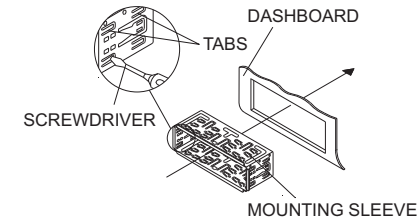

- 4.** Place the radio in front of the dashboard opening so the wiring can be brought through the mounting sleeve.
- 5.** Follow the wiring diagram carefully and make certain all connections are secure and insulated with crimp connectors or electrical tape to ensure proper operation.
- 6.** After completing the wiring connections, reconnect battery and turn the unit on to confirm operation (vehicle ignition switch must be on). If the unit does not operate, recheck all wiring until the problem is corrected. Once proper operation is achieved, turn the ignition switch off and proceed with final mounting of the chassis.
- 7.** Carefully slide the radio into the mounting sleeve making sure it is right-side-up until it is fully seated and the spring clips lock it into place.
- 8.** Test radio operation by referring to the operating instructions for the unit.

### Removing the Unit

To remove the radio after installation:

- 1.** Make sure the ignition is turned off, and then disconnect the cable from the vehicle's battery negative (-) terminal.
- 2.** Insert the removal keys straight into the holes on the front of the unit, as far as they will go.
- 3.** Pull the radio straight out.

# WIRING

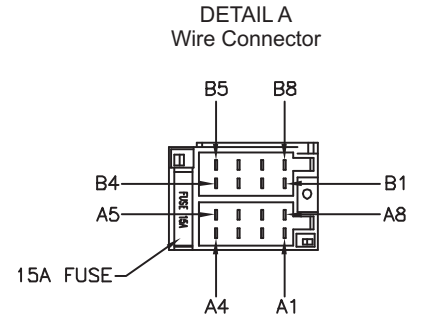
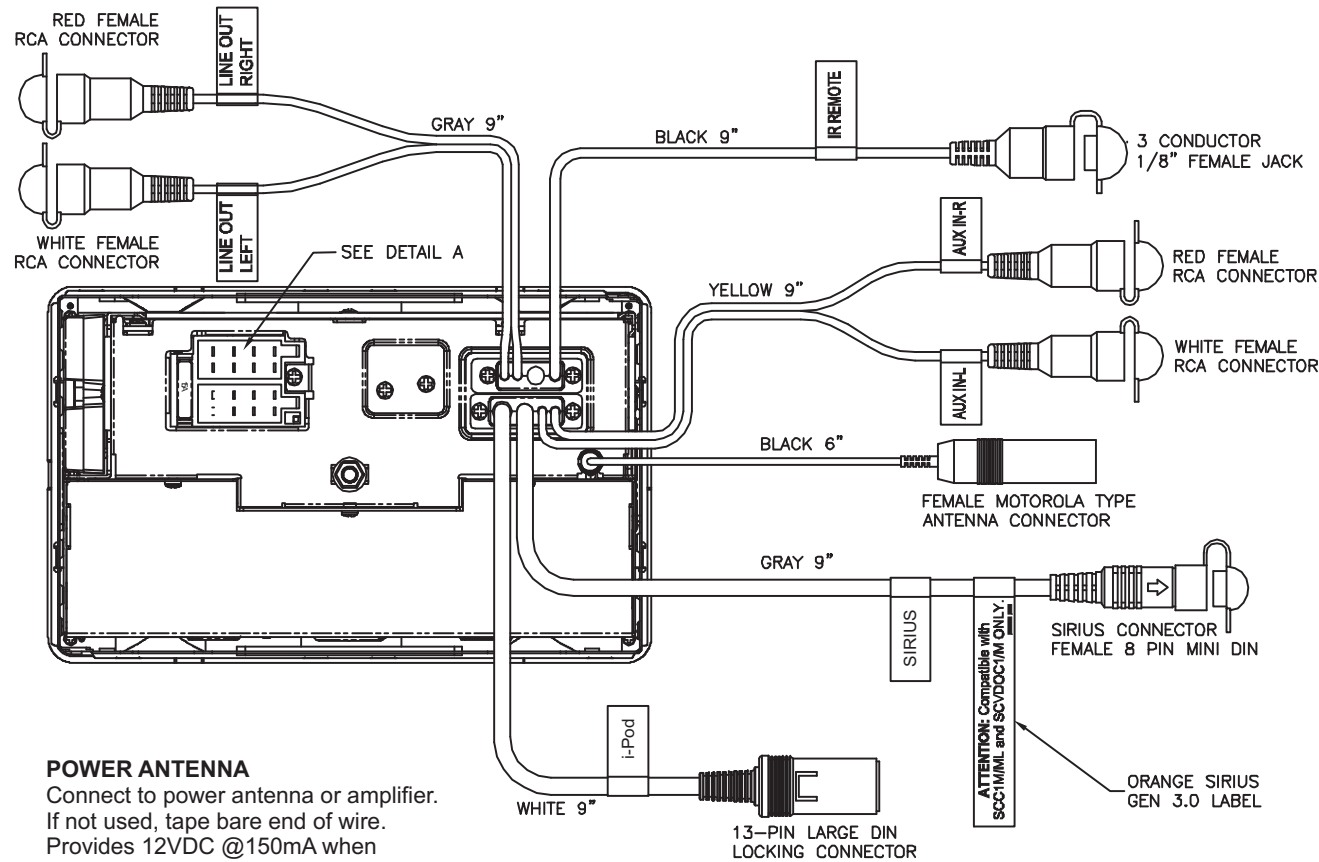

DETAIL A SHOWN FROM PIN VIEW

| PIN NO. | DESCRIPTION                |
|---------|----------------------------|
| A1      | RIGHT REAR SPEAKER (+)     |
| A2      | RIGHT FRONT SPEAKER (+)    |
| A3      | LEFT FRONT SPEAKER (+)     |
| A4      | LEFT REAR SPEAKER (+)      |
| A5      | LEFT REAR SPEAKER (-)      |
| A6      | LEFT FRONT SPEAKER (-)     |
| A7      | RIGHT FRONT SPEAKER (-)    |
| A8      | RIGHT REAR SPEAKER (-)     |
| B1      | NO CONNECTION              |
| B2      | NO CONNECTION              |
| B3      | POWER ANTENNA              |
| B4      | +12 VDC ACCESSORY IGNITION |
| B5      | GROUND                     |
| B6      | BACKLIGHT DIMMER           |
| B7      | +12V BATTERY CONSTANT      |
| B8      | NO CONNECTION              |

**POWER ANTENNA**  
 Connect to power antenna or amplifier. If not used, tape bare end of wire. Provides 12VDC @150mA when radio is active.

**+12 VDC ACCESSORY IGNITION**  
 Connect to existing radio accessory fuse or +12 VDC switched power source.

**GROUND**  
 Connect to ground terminal or clean unpainted metal part of chassis.

**+12V BATTERY CONSTANT**  
 Connect to battery or 12 volt power source that is always live. The radio will not work if this wire is not connected.

## BASIC OPERATION

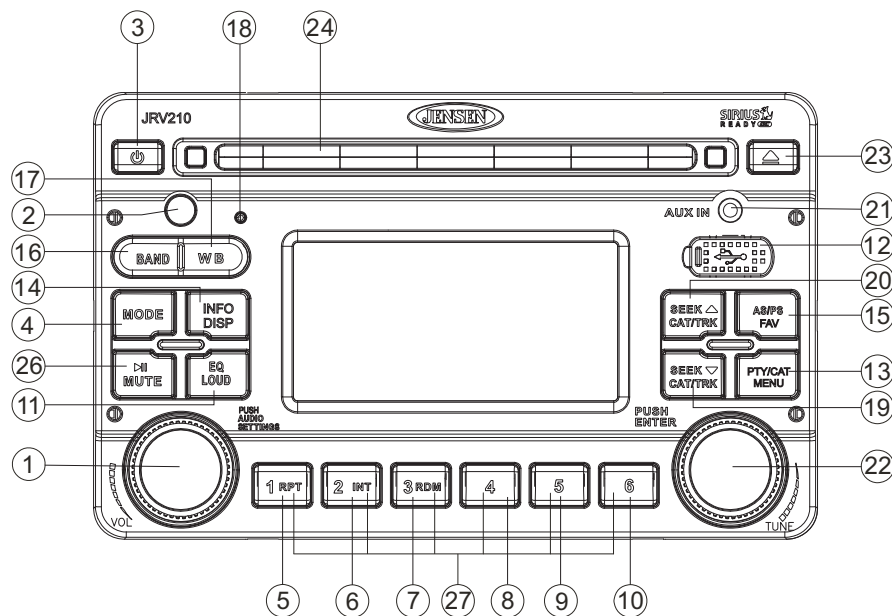

### Power On/Off

Press the power button (3) to turn the unit on/off.

### Volume Control

To increase the volume, rotate the **VOL/AUDIO SETTINGS** control (1) clockwise. The maximum level is "40".

To decrease the volume, rotate the **VOL/AUDIO SETTINGS** control counter-clockwise.

### Mute

Press the **MUTE** button (26) on the control panel to mute the audio output. "MUTE" will appear on the LCD display.



Press **MUTE** again to restore the audio output to the previous level.

### Mode

Press the **MODE** button (4) on the control panel to select a different mode of operation, as indicated on the display panel. Available modes include TUNER, SIRIUS, CD, USB, IPOD and AUXILIARY.

**NOTE: IPOD or SIRIUS mode will be skipped if the module is not installed.**

### Reset

Use a ball point pin or thin metal object to press the **RESET** button (18). The reset button should be activated for the following reasons:

- initial installation of the unit when all wiring is completed
- function buttons do not operate
- error symbol on the display

### Audio Menu

Press the **VOL/AUDIO SETTINGS** control (1) on the control panel to access the Audio Menu. You can navigate through the Audio Menu items by pressing the **VOL/AUDIO SETTINGS** control repeatedly. Once the desired menu item appears on the display, adjust that option by turning the **VOL/AUDIO SETTINGS** control (1) within 5 seconds. The unit will automatically exit the Audio Menu after five seconds of inactivity. The following menu items can be adjusted. Use the volume control to adjust the Bass level range from "-7" to "+7".



#### Treble Level

Use the volume control to adjust the Treble level range from "-7" to "+7".

#### Balance (BAL)

Use the volume control to adjust the Balance between the left and right speakers from "L12" (full left) to "R12" (full right).

#### Fader (FAD)

Use the volume control to adjust the Fader between the rear and front speakers from "R12" (full rear) to "F12" (full front).

## System Menu

1. Press and hold the **PTY/CAT/MENU** button (13) for more than 3 seconds to enter the system menu.
2. Rotate the **TUNE/ENTER** control (22) to highlight the desired item.
3. Press the **TUNE/ENTER** control to select a value for the highlighted item.

The following feature functions can be adjusted:

- Key Beep (Click / Beep / Off): Turn the audible beep On/Off (heard when functions/ buttons are selected).
- LCD Backlight (1-10): Adjust LCD brightness.
- LCD Contrast (1-10): Adjust LCD contrast.
- LCD Color (Invert/Normal)
- Tuning Region (USA / EURO): Set frequency spacing for various regions.
- Power-Off Clock (On / Off)
- Clock Format (12Hour / 24Hour): Select 12 or 24 hour display mode.
- Set Clock (HH : MM):
  - Press the **TUNE/ENTER** control (22) to view the clock set screen.
  - Rotate the **TUNE/ENTER** control to adjust the hour.
  - Press the **TUNE/ENTER** control to move to the minutes field.
  - Rotate the **TUNE/ENTER** control to adjust the minutes.
  - Press the **TUNE/ENTER** control to set the clock and return to the menu.
- Preset-Only Tuning (On / Off)
- Sirius Settings Menu (only appears when SIRIUS tuner is connected and in SIRIUS mode)
  - Clock Autoset (On / Off): Set "On" to allow auto set of clock time.
  - Timezone (Atlantic / Eastern / Central / Mountain / Pacific / Alaska)
  - DST Enabled (Yes / No): Set "Yes" to observe daylight savings time.
  - Clear Skipped <Enter>: Enter to view options (ENTER for "Yes", MENU for "No").
  - Skipped Channels: List of Channels (Skipped / Visible)
  - Set Lock Code: \_\_\_\_ : Enter 4-digit code.
  - Locked Channels: List of channels (Locked / Unlocked)
  - Enable Song Seek (Yes / No): set "Yes" to receive song seek alerts.
  - Remove Favorites: List of Favorite Songs (Enable / Disable / Delete)
  - Remove All Favorites <Enter>: Enter to view options (ENTER for "Yes", MENU for "No")
- iPod Auto-Select (On / Off): Choose "On" to automatically detect and playback iPod when connected or "Off" to use the **MODE** button (4) to select the iPod source.
- Weather Alert Configuration
  - Min Alert Level (All / None / Warnings / Watches)
  - Auto-On Enable (Yes / No): Select "Enabled" to turn on the radio when NOAA alerts are issued. This function only works when the +12V switched is on.
  - Alert Volume (Select Volume Level 0-40)
  - Clear SAME Codes <ENTER>
  - SAME Code: \_\_\_\_\_
  - SAME Code: \_\_\_\_\_
  - SAME Code: \_\_\_\_\_
  - SAME Code: \_\_\_\_\_
  - SAME Code: \_\_\_\_\_
  - SAME Code: \_\_\_\_\_
  - SAME Code: \_\_\_\_\_

- Reset To Defaults <ENTER>: Press the **TUNE/ENTER** control to return the EEPROM to factory default set up values.
- Update Firmware <ENTER>: Press the **TUNE/ENTER** control to apply recent software updates.

## Equalizer

Press the **EQ/LOUD** button (11) to select one of the following equalization sound settings: Flat Rock, Classical, Pop or User.

## Loudness

Press and hold the **EQ/LOUD** button (11) to turn the loudness feature setting on/off. Loudness "ON" is indicated by "LD" at the bottom of the screen.

## Auxiliary Input

To access an auxiliary device:

1. Connect the portable audio player to the 3.5mm stereo AUX IN connector on the front panel (21) or to the RCA phono AUX IN cables on the back of the radio.
2. Press the **MODE** button to select Auxiliary mode.
3. Press **MODE** again to cancel Auxiliary mode and select another available playback mode.

---

**NOTE: The front AUX input overrides the rear Auxiliary Input.**

---

## Info/Scroll

When in Sirius Satellite Radio, USB or iPod mode, press the **INFO DISP** button (14) to switch between artist and title program information.

## Remote Sensor

Point the remote control handset (sold separately) at the remote sensor IR (2) and press the function keys on the handset to control the system.



## TUNER OPERATION

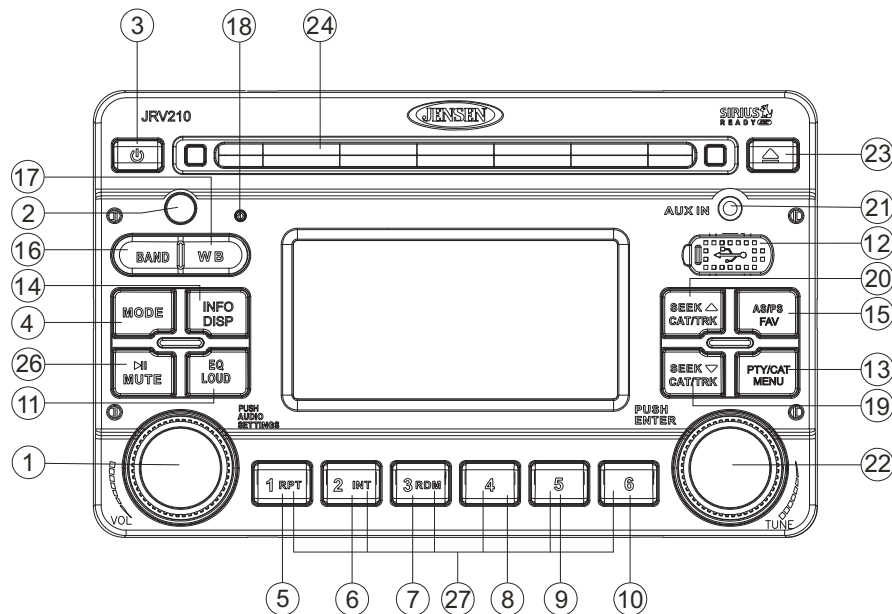

### Select a Band

Press the **BAND** button (16) on the control panel to change between three FM bands and two AM bands.

### Tuning

Rotate the **TUNE/ENTER** control (22) clockwise or counter-clockwise to tune up or down in one step increments. Press the **SEEK V** (19) or **SEEK ^** button (20) to seek the next strong station.

### Preset Stations

Six numbered preset buttons store and recall stations for each band (FM1, FM2, FM3, AM1 and AM2).

#### Store a Station

Tune radio to desired station. *Press and hold* a preset button (27) for three seconds. A beep tone will confirm the stored station and the preset number will appear in the display.

#### Recall a Station

Select a band (if needed). Press a preset button (27) to select the corresponding stored station.

### Automatic Store / Preset Scan (AS/PS/FAV)

#### Automatic Store

Select a band (if needed). *Press and hold* the **AS/PS/FAV** (15) button for more than three seconds to automatically select eighteen strong stations for FM or twelve for AM and store them in all bands. New stations replace any stations already stored in that band. After stations have been stored, the radio will enter Preset Scan and preview each stored station.

#### Preset Scan

Select a band (if needed). Press **AS/PS/FAV** (15) to scan stations stored in all bands. The unit will pause for ten seconds at each preset station. Press **AS/PS/FAV** again to stop scanning when the desired station is reached.

### RBDS Operation

This unit is equipped to display RBDS (Radio Broadcast Data Service) information when broadcast by the radio station.

---

**NOTE: Radio stations broadcasting RBDS may not be available in your listening area.**

---

In FM radio mode, press the **PTY/CAT/MENU** button (13) to list the following Program Type (PTY) options: ANY / News / Information / Sports / Talk / Rock / Classic Rock / Adult Hits / Soft Rock / Top 40 / Country / Oldies / Soft / Nostalgia / Jazz / Classical / Rhythm and Blues / Soft Rhythm & Blues / Foreign Language / Religious Music / Religious Talk / Personality / Public / College / Weather / Emergency Test / ALARM! ALARM!

To search for stations in a PTY category:

1. Press the **PTY/CAT/MENU** button (13) to view the current PTY category.
2. Rotate the **TUNE/ENTER** control (22) to move through the list of available categories and select the program type you wish to search.
3. After selecting the desired PTY, press the **TUNE/ENTER** control (22) to search the band for broadcasts of this type.

---

**NOTE: Performing a PTY search on "ANY" will Seek Tune and stop on any station broadcasting RBDS, regardless of the program type.**

---

### Stereo (ST)

The unit will automatically pick up an FM stereo signal, when available. When in stereo mode, the "ST" icon appears in the display. When no stereo signal is available, the unit will automatically revert to mono operation, and no icon will be displayed.



## Weather Band Operation

### What is the NOAA Weather Radio/Weatheradio Canada?

NOAA (National Oceanic and Atmospheric Administration) is a nationwide system that broadcasts local weather emergency information 24 hours a day via the National Weather Service (NWS) network. The U.S. network has more than 530 stations covering the 50 states as well as the adjacent costal waters, Puerto Rico, the U.S. Virgin Islands and the U.S. Pacific Territories. Each local area has its own transmitting station and there are a total of seven broadcasting frequencies used. A similar system is available in Canada under the Weatheradio Canada service administered by Environment Canada.

### Tuning to Weatherband

In any mode, press the **WB** button (17) to access the weather band (NOAA seven frequency broadcast). The indication "WB" will appear on the display panel, along with the current number and channel indication: "WB-1", "WB-2", "WB-3", "WB-4", "WB-5", "WB-6" or "WB-7". The seven frequencies are shown in the following table:

| Frequency (MHz) | Preset |
|-----------------|--------|
| 162.400         | 2      |
| 162.425         | 4      |
| 162.450         | 5      |
| 162.475         | 3      |
| 162.500         | 6      |
| 162.525         | -      |
| 162.550         | 1      |

The above table also shows which preset button will access the frequency. Note that one frequency cannot be accessed using a preset button. The frequency can only be reached using the tuning controls.

- Press the **SEEK**  $\wedge$  /  $\vee$  buttons (20/19) to choose a channel from CH1 – CH7. You can also press the six preset buttons (27) to select CH1 – CH6 directly.
- Press the **BAND** (16) or **MODE** (4) button to exit weather band mode.

**NOTE: The weather band channel frequency is fixed in preset memory and cannot be changed.**

### How many stations can I expect to receive?

Since the broadcasts are local weather and information, the transmission power is usually very low (much less than standard AM or FM stations) so you will usually receive only one station unless you are on the edge of two or more broadcast signals. The most you will receive will be two or three, and that is rare.

### Is it possible I won't receive any stations?

Depending on where you are located, there is a possibility you will receive only a very weak signal or none at all. Also, similar to AM and FM signals, weatherband signals are subject to surrounding conditions, weather, obstructions of the signal by hills or mountains, etc.

### NOAA Weather Alert

The Weather Alert function adds an additional level of user safety by automatically switching from any of the available function modes to weather band for a minimum of 60 seconds if a NOAA warning tone (1050 Hz) is received/detected. If no additional warning tone is received for 60 seconds, the unit will switch back to the last known function mode.

The JVR210 is equipped with a weather alert level (Min Alert Level) and weather alert power (Auto-On Enable) feature that will cause the radio to turn on automatically when a weather alert is detected, adding an additional level of user safety. When the weather alert level is set to "All", "Warnings" or "Watches" the weather alert function automatically switches from any of the available function modes (Tuner, Sirius, CD, iPod, AUX) to Weather Band when the selected NOAA warning type is received/detected.

See "System Menu" on page 7 to learn how to turn the WB Alert and Alert Power features on.

### SAME Decoding and Filtering

Specific Area Message Encoding (SAME) data is also broadcast prior to alert broadcasts. SAME data contains information about the geographic region affected by the alert, the type of alert, and its effective time. The geographic region included in the SAME data is called the Geographical Area code and has the form PSSCCC where "P" represents a portion of the county, "SS" is a two-digit state, territory, or offshore marine area identifier and "CCC" identifies the county, province, or major metropolitan area within the state. This unit can be configured through the system setting menu with up to seven Geographical Area codes to limit the automatic tuning or power on functions described above.

SAME data also includes the type of alert being broadcast. This unit can be configured through the System Setting Menu to limit the automatic tuning or power on functions based on the type of alert.

SAME is activated by programming a 6 digit code - called a FIPS code - into your radio. The FIPS code or Federal Information Processing System code is a six digit code that identifies the states and counties (or parishes) in the United States. The first digit identifies the county subdivision. The next two digits identify the state or territory, and the last three identify the county. The FIPS code for your area can be found by calling the NWS toll free number or visiting the web site.

The phone number is 1-888-NWS-SAME (1-888-697-7263) Upon calling, an automated system will prompt you to enter your state and county. When you confirm the information, the system will provide your six digit FIPS code.

The web site is: [www.nws.noaa.gov/nwr/indexnw.htm](http://www.nws.noaa.gov/nwr/indexnw.htm). Upon selecting your state from the chart, you will see a listing of all the counties in that state. For each county there is a listing of the SAME# (FIPS code), the location of the transmitter, the WB frequency, the call sign, the transmitter power and miscellaneous remarks.

**NOTE: Because broadcast areas overlap you may want to set more than one S.A.M.E. location. If you live near the border between counties, you may want to receive alerts from more than one tower.**

Your radio is capable of being programmed with up to 7 different FIPS location codes. The default code has been programmed at the factory - 000000 - to respond to all messages within your area.

## CD/MP3/WMA OPERATION

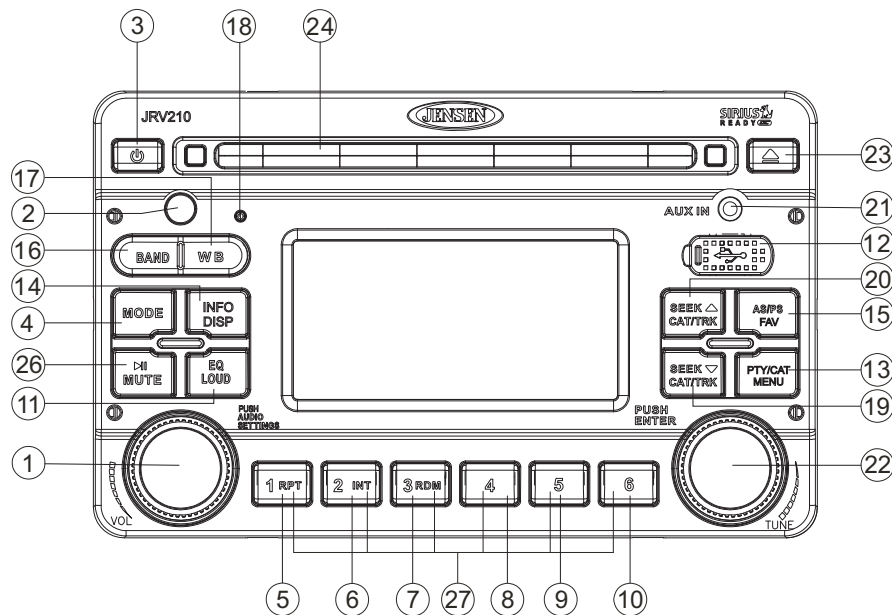

### Inserting and Ejecting a Disc

Insert a disc, label-side up, into the disc slot (24) with the unit turned on. The unit will automatically draw the disc in and play the first track on the disc.

Press the eject ▲ button (23) to stop disc play and eject the disc. The unit does not have to be turned on to eject the disc.

**NOTE:** The car ignition does not have to be on to insert/eject a disc.

### MP3 Specifications

- A directory that does not include an MP3 file is skipped.
- Maximum number of folders: 512 (including skipped directories)
- Maximum number of folder levels: 12
- Maximum number of MP3 files: 999
- Maximum number of characters for MP3 file name and folder name: 32
- Sampling frequency: 16KHz, 22.05KHz, 24KHz, 32KHz, 44.1KHz, 48KHz.
- Bit rates: maximum 384 Kbps.
- Maximum number of Characters of ID3 Tag:
  - ID3 Tag version 1.0: 32
  - ID3 Tag version 2.x: 32

*After loading an MP3 disc, files and folders are accessed in the order in which they were written by the CD writer. Therefore, the playing order may not be the same as the order in which they are expected to played.*

### Controlling Disc Playback

#### Selecting Tracks

Press the **SEEK V** (19) or **SEEK A** button (20) to advance to the next track on the disc. The selected track number will appear on the display. *Press and hold* the **SEEK V** (19) or **SEEK A** button (20) to fast forward or fast reverse through the disc. Playback begins when the button is released.

#### Browse Files/Folders

For an MP3/WMA disc, press the **PTY/CAT/MENU** button (13) to view a list of all files/folders. Rotate the **TUNE/ENTER** control (22) to move through the list. Press the **TUNE/ENTER** control select the highlighted file/folder.

Press the **PTY/CAT/MENU** button to reverse navigate and return to the root level.

#### Play/Pause Disc Playback

Press the **>||** button (26) to suspend disc play. Press the **>||** button again to resume disc Play.

#### Previewing Tracks

Press the **INT** button (6) on the control panel to play the first 10 seconds of each track sequentially. Press **INT** again to stop Intro Scan and resume normal play at the current track.

#### Repeat Play

Press the **RPT** button (5) during disc play to repeat play the current track. Press **RPT** again to stop repeat play.

#### Random Play

Press the **RDM** button (7) on the control panel during disc play to play all tracks in the current folder in random, shuffled order. Press **RDM** again to stop random play.

### INFO DISP Button

During MP3 playback, press the **INFO DISP** button (14) to display available ID3 tag information to emphasize artist or song title.

## USB OPERATION

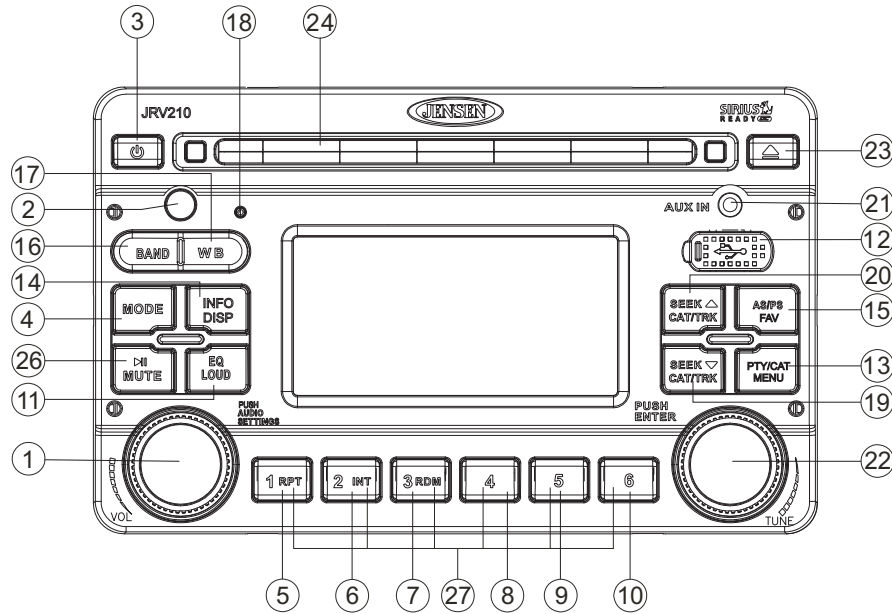

### Inserting and Removing a USB Device

#### Inserting a USB Device

Insert the USB device into the USB jack (12) and the unit will read the files on the USB device automatically.

#### Removing a USB Device

Press the **MODE**, **WB**, or **BAND** button, insert a CD, or connect an iPod to change to another mode and then remove the USB device from the USB connector.

### Accessing USB Mode

Press the **MODE** button (4) to access the USB device from any other mode.

**NOTE:** After loading a USB device, files and folders are accessed in the order in which they were written to the device. Therefore, the playing order may not be the same as the order in which they are expected to played.

### Controlling Song File Playback

#### Selecting Tracks

Press the **SEEK V** (19) or **SEEK Λ** button (20) to advance to the next file. The selected file name will appear on the display. Press and hold the **SEEK V** (19) or **SEEK Λ** button (20) to fast forward or fast reverse through the current file. Playback begins when the button is released.

#### Browse Files/Folders

Press the **PTY/CAT/MENU** button (13) to view a list of all files/folders. Rotate the **TUNE/ENTER** control (22) to move through the list. Press the **TUNE/ENTER** control select the highlighted file/folder.

Press the **PTY/CAT/MENU** button to reverse navigate and return to the root level directory.

#### Play/Pause Disc Playback

Press the **>||** button (26) to suspend playback. Press the **>||** button again to resume playback.

#### Previewing Tracks

Press the **INT** button (6) on the control panel to play the first 10 seconds of each file in the current folder sequentially. Press **INT** again to stop Intro Scan and resume normal playback of the current file.

#### Repeat Play

Press the **RPT** button (5) during disc play to repeat the current file. Press **RPT** again to stop repeat play.

#### Random Play

Press the **RDM** button (7) to play all files in the current folder in random, shuffled order. Press **RDM** again to stop random play.

**NOTE:** USB port will not work with iPod. USB port will not charge all devices.

## SIRIUS RADIO OPERATION

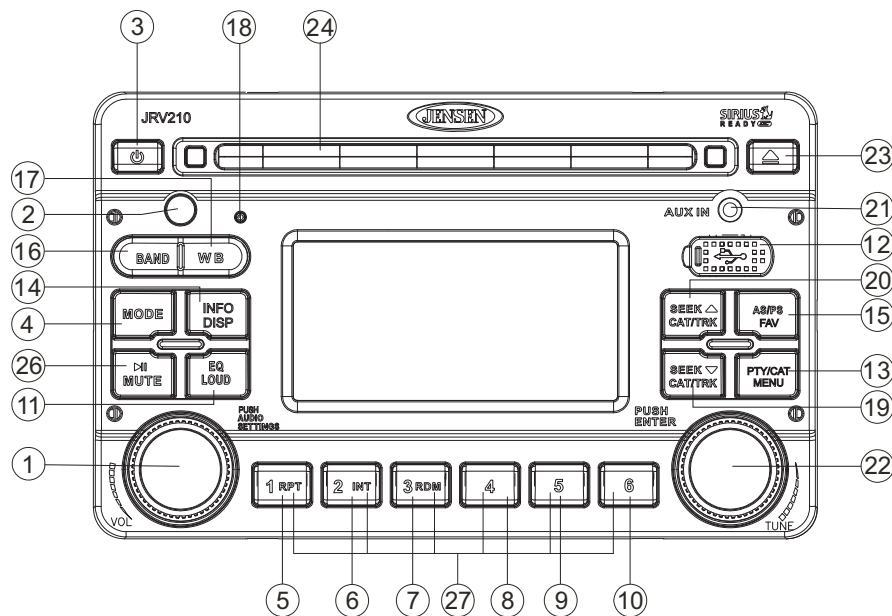

**NOTE:** Access to Sirius® satellite radio requires installation of a separate Sirius tuner and antenna. Listeners can subscribe to Sirius radio on the internet by visiting [www.sirius.com](http://www.sirius.com), or by calling (888) 539-SIRIUS. Customers should have their Sirius ID ready (Sirius ID is located on the Sirius tuner, sold separately). Customers can listen to music samples by tuning to channel 184.

### Switching to SIRIUS Mode

Press the **MODE** button (4) to change the mode to Sirius Satellite Radio mode.

### Activating Sirius Satellite Radio

Before you listen to Sirius Radio, you must subscribe to the service using your radio's identification number. To display the Radio ID, press the **SEEK A** or **SEEK V** button (20, 19) to access channel "000". The screen displays "SID" followed by an 12 figure ID number.

### Selecting a Band

In Sirius mode, press the **BAND** button (16) to access the Sirius user-preset channel groups in the following order: SIR1, SIR2, SIR3.

### Tuning a Channel

Rotate the **TUNE/ENTER** control (22) clockwise or counter-clockwise to tune up or down in one step increments.

The channel information display can be changed to emphasize either Artist or Song Title by pressing the **INFO DISP** button (14).

### Storing Preset Channels

The preset buttons (27) can be used to store 6 channels per band (SIR1, SIR2 and SIR3), allowing convenient access to your favorite channels.

#### Programming Channels

1. Select the channel you want to store in memory.
2. *Press and hold* a preset button (27) until the corresponding preset button number appears on the screen.
3. Repeat steps 1 and 2 to program additional channels.

#### Recalling a Preset Channel

Press one of the six preset buttons (27) within a selected band to tune a preset channel directly.

### Preset Scan

Press the **AS/PS/FAV** button (15) to preview each stored preset channel in SIR1, SIR2 and SIR3 for 10 seconds. Press the **AS/PS/FAV** button again to stop scanning and play the current channel.

## Favorites (Song/Artist Seek)

This feature lets you store and search for up to 15 Artist/Song combinations on Sirius Satellite Radio.

1. While the current song is playing, press and hold the **AS/PS/FAV** button (14).
2. Press the **TUNE/ENTER** control (22) to select the Artist to be stored or press the **AS/PS/FAV** button to select the Song to be stored.

Next time the stored artist or song is played on Sirius Satellite Radio, you will be notified with an alert and can then choose to tune to the channel playing the Song or Artist using the **TUNE/ENTER** control. The list of stored Artists/Songs can be managed through the System Menu under the "Sirius Satellite Radio" menu. See "System Menu" on page 7.

## SIRIUS Tuning Modes

### Category Mode

1. Press the **PTY/CAT/MENU** button (13) to access category mode.
2. Press the **SEEK/CAT/TRK  $\wedge$  / V** buttons (20/19) to view available categories. Each category title and associated channels will be displayed in increments. While in the category mode, the individual channels within a category may be accessed by rotating the **TUNE/ENTER** control (22).
3. Once a highlighted channel has been selected, press the **TUNE/ENTER** control to tune to that channel.
4. While viewing a category list, press the **INFO DISP** button (14) to change display information between Channel Name, Artist, or Song Title.



### Direct Tune Mode

1. *Press and hold* the **TUNE/ENTER** control (22) to switch to Direct Tune/Skip Channel mode. After accessing Direct mode, "ENTER CHANNEL NUMBER \_ \_ \_" appears on the display.
2. Turn the **TUNE/ENTER** control (22) to select a number for the hundreds digit position.
3. Press the **TUNE/ENTER** control to confirm entry of the hundreds digit. The tens digit will flash on/off.
4. Turn the **TUNE/ENTER** control to select a number for the tens digit position.
5. Press the **TUNE/ENTER** control again to confirm entry of the tens digit. The ones digit will flash on/off.
6. Turn the **TUNE/ENTER** control to select a number for the ones digit position.
7. Press the **TUNE/ENTER** control to tune to the selected channel.

## Channel Lock

Access Channel Lock through the System Menu under the "Sirius Satellite Radio" menu. See "System Menu" on page 7.

1. Select "Set Lock Code."
2. No channels can be locked with the default 0000 code. To set the lock code:
  - a. Rotate the **TUNE/ENTER** control (22) to enter the first digit of the default code.
  - b. Press the **TUNE/ENTER** control to move to the next digit.
  - c. Repeat above steps to enter all 4 digits of the default code.
  - d. Rotate the **TUNE/ENTER** control to enter the first digit of the new code.
  - e. Press the **TUNE/ENTER** control to move to the next digit.
  - f. Repeat above steps to enter all 4 digits.
  - g. Repeat above steps to confirm the new code.

8. After setting a new four digit code, you can lock channels using the "Locked Channels" option on the System Menu.
9. Upon entering the Locked Channels list, you will be prompted to enter your four digit code.
  - a. Rotate the **TUNE/ENTER** control (22) to enter the first digit.
  - b. Press the **TUNE/ENTER** control to move to the next digit.
  - c. Repeat above steps to enter all 4 digits.
4. After entering the code, you can navigate the list using the **TUNE/ENTER** control to highlight the channels.
5. Press the **TUNE/ENTER** control to Lock (indicated by a  icon) or Unlock () the selected channel.

## iPod OPERATION

This unit is equipped with an iPod ready function that will allow you to control your iPod (if compatible) using the control panel control buttons. The following iPod versions are supported:

- iPod Nano (1G, 2G, 3G, 4G and 5G)
- iPod 5G
- iPod Classic
- iPhone, iPhone 3G, iPhone 3GS
- iPod Touch
- iPod Touch 2G

**NOTE: iPod and iPod Cable sold separately.**

### Accessing iPod Mode

If AUTO IPOD "ON" is selected in the system menu, your iPod will play automatically when connected to the unit. "iPod" will appear in the upper left corner of the display.

If AUTO IPOD "OFF" is selected in the system menu, your iPod will not play automatically when connected. In this case, press the **MODE** button (4) to change to IPOD mode.

If you press the **BAND**, **WB** or **MODE** button during iPod playback, the iPod will resume playback when you return to IPOD mode.

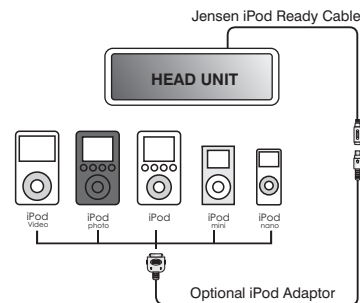

### Turning the iPod On/Off

The iPod power turns on automatically when an iPod is connected to 30-pin iPod cable, as long as the vehicle ignition is turned on. You can turn the iPod off by disconnecting it from the cable or by turning the ignition off. When the ignition is turned off, the iPod will pause and then enter sleep mode after 2 minutes. While the iPod is connected, the power cannot be turned on or off from the iPod itself.

**NOTE: The iPod will continuously recharge when connected to the unit, as long as the vehicle ignition is turned on.**

### Selecting a Playlist

1. When an iPod is playing, press the **PTY/CAT/MENU** button (13) to display the playlists on the LCD.
2. Turn the **TUNE/ENTER** control (22) to change the playlist between Artist / Album /Genre / Song / Audiobook / Podcast.
3. Press the **TUNE/ENTER** control to confirm the selected playlist.
4. While searching a playlist, press the **PTY/CAT/MENU** button (13) to navigate back through the list.

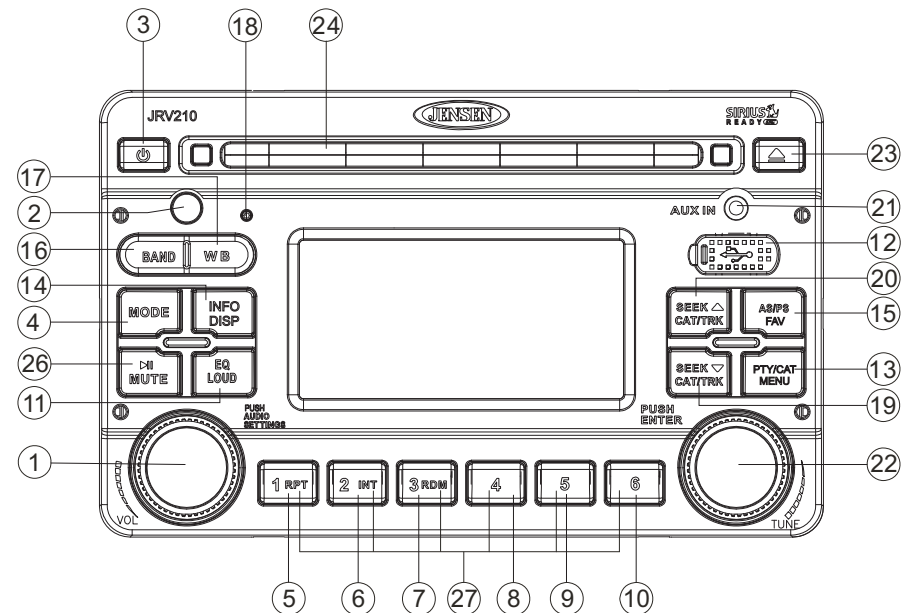

### Controlling Playback

#### Play/Pause

Press the **>||** button (26) to suspend playback. Press the **>||** button again to resume playback.

#### Selecting Tracks

During playback, press the **SEEK V / ^** button (19, 20) to play the previous or next track in the current category. Press the **SEEK ^** button (20) once to play the song from the start position or press **SEEK V** twice to play the previous track.

Press and hold the **SEEK V / ^** button (19, 20) to fast reverse/forward the song. iPod playback will continue when the button is released.

The track information display can be changed to emphasize either artist or song title by pressing the **INFO/DISP** button (14).

#### Repeat Play

Press the **RPT** button (5) to repeat play the current song. Press **RPT** again to stop repeat play.

#### Previewing Tracks

Press the **INT** button (6) on the control panel to play the first 10 seconds of each file in the current folder sequentially. Press **INT** again to stop Intro Scan and resume normal playback of the current file.

**Random Play**

During playback, press the **RDM** button (7) to play all songs in the current category in random order. Random play will begin once the current song has finished playing. Press **RDM** again to stop random playback.



## REMVRCC CARD REMOTE CONTROL (SOLD SEPARATELY)

- **POWER:** Powers on/off.
- **MODE:** Cycles through all available play modes (Radio, CDP, SAT, iPod, Aux).
- **VOL  $\wedge$  / V:** Adjusts volume level.
- **AUDIO MENU:** Accesses Audio and System Menu.
- **ENTER:** Enter key.
- **TUNE  $\wedge$  / TUNE  $\vee$ :** Changes frequency/channel by one step in AM/FM/SAT modes.
- **P-TUNE  $\wedge$  / V:** Navigate/tune to preset stations.
- **MUTE:** Mutes audio in all modes.
- **WB:** Directly accesses weatherband.
- **BAND:** Sequences bands/preset-banks (FM1, FM2, FM3, AM1, AM2) in Radio mode. Sequences preset banks (SR1, SR2, SR3) in satellite mode.
- **AS/PS MENU:** Scans all stored presets in SAT or radio mode (any button press during PS will stop the scan).
- **INFO SCROLL:** Sets clock. Scrolls information.
- **|<< TRK/TRK >>|/SEEK:** Select next/previous track, file or station. *Press and hold* to seek next/previous station. Navigate list in iPod mode.
- **CAT-/+:** Changes category in SAT/iPod mode.
- **EQ LOUD:** Turns on/selects preset Equalizer functions.

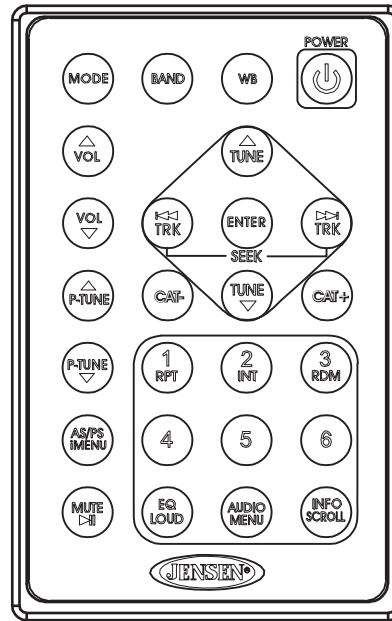

## CARE AND MAINTENANCE

- Keep the product dry. If it does get wet, wipe it dry immediately. Liquids might contain minerals that can corrode the electronic circuits.
- Keep the product away from dust and dirt, which can cause premature wear of parts.
- Handle the product gently and carefully. Dropping it can damage circuit boards and cases, and can cause the product to work improperly.
- Wipe the product with a dampened cloth occasionally to keep it looking new. Do not use harsh chemicals, cleaning solvents, or strong detergents to clean the product.
- Use and store the product only in normal temperature environments. High temperature can shorten the life of electronic devices, damage batteries, and distort or melt plastic parts.

### Ignition

The most common source of noise in reception is the ignition system. This is often a result of the radio being placed relatively close to the ignition system (engine). This type of noise can be easily detected because it will vary in intensity of pitch with the speed of the engine.

Usually, the ignition noise can be suppressed considerably by using a radio suppression type high voltage ignition wire and suppressor resistor in the ignition system. (Most vehicles employ this wire and resistor, but it may be necessary to check them for correct operation.) Another method of suppression is the use of additional noise suppressors. These can be obtained from most CB/A radio or electronic supply shops.

### Interference

Radio reception in a moving environment (automobile) is very different from reception in a stationary (home) environment. AM reception will deteriorate when passing through a tunnel or when passing under high voltage lines. Noise can be picked up from passing automobiles. Although AM is subject to environmental noise, it can be received at great distances. This is because broadcasting signals follow the curvature of the earth and are reflected back by the upper atmosphere.

## TROUBLESHOOTING

| Symptom   | Cause   | Solution   |
|---|---|--|
| No power  | The vehicle's ignition is not on  | If the power supply is properly connected to the vehicle accessory terminal, switch the ignition key to "ACC". |
|   | The fuse is blown   | Replace the fuse.  |
| Disc cannot be loaded or ejected  | Presence of CD disc inside the player   | Remove the disc in the player and insert the new one.  |
|   | Inserting the disc in reverse direction   | Insert the compact disc with the label facing upward.  |
|   | Compact disc is extremely dirty or disc is defective  | Clean the disc or try to play a new one.   |
|   | Temperature inside the vehicle is too high  | Wait until the ambient temperature returns to normal.  |
|   | Condensation  | Leave the player off for an hour or so, then try again.  |
| No sound  | Volume is too low   | Adjust volume to audible level.  |
|   | Fader is set incorrectly  | Press <b>AUDIO</b> button to access menu and adjust Fader settings.  |
|   | Wiring is not properly connected.   | Check wiring connections.  |
| The operation keys do not work  | The built-in microcomputer is not operating properly due to noise   | Press the <b>RESET</b> button.   |
| Sound skips   | The installation angle is more than 30 degrees.   | Adjust the installation angle to less than 30 degrees.   |
|   | The disc is dirty or defective.   | Clean the disc and try to play again or use new disc.  |
| Cannot tune to radio station, auto-seek does not work                     | The antenna cable is not connected.   | Insert the antenna cable firmly.   |
|   | The signals are too weak.   | Select a station manually.   |
| Radio automatically switches to WB (Weather Band)                         | This is a normal function. A Weather Band warning is being received.  | If you do not want this to occur, set the WB Alert setting to "OFF" in the System menu.                        |
| Radio automatically turns on (ignition on) and tunes to WB (Weather Band) | This is a normal function when the Alert Pwr feature is set to "AUTO" in the system menu. A Weather Band warning is being received. | If you do not want this to occur, set the Alert Pwr setting to "OFF" in the System menu.                       |



## SPECIFICATIONS

### CD

Signal to Noise Ratio . . . . .  $\geq 60$ dB  
 Channel Separation . . . . . : More than 50 dB  
 Frequency Response . . . . . : 20Hz - 20kHz  
 CD Format Compatibility . . . . . CD-DA, CD-R, CD-RW

### FM Radio

Frequency Range (USA) . . . . . 87.5 to 107.9 MHz  
 Frequency Range (Europe) . . . . . 87.5 to 108 MHz  
 Sensitivity (S/N=30dB) . . . . .  $4\mu$ V  
 Image Rejection . . . . . >45 dB  
 Stereo Separation . . . . . >25 dB

### AM/MW

Frequency Range (USA) . . . . . 530-1710KHz  
 Frequency Range (Europe) . . . . . 522-1620KHz  
 Sensitivity (S/N=20dB) . . . . . 36 dB

### General

Operating Voltage . . . . . DC 12 Volts  
 Grounding System . . . . . Negative Ground  
 Speaker Impedance . . . . . 4-8 ohms per channel  
 Tone Controls:  
     Bass (at 100 Hz) . . . . . :  $\pm 10$  dB  
     Treble (at 10 kHz) . . . . . :  $\pm 10$  dB  
 Power Output . . . . . 50W x 4  
 Current Drain . . . . . 15 Ampere (max.)  
 Dimensions . . . . . 80 (W) x 183 (D) x 100 (H)  
 Digital Media File Format Compatibility . . . . . MP3, WMA



ASA Electronics Corporation

[www.asaelectronics.com](http://www.asaelectronics.com)

[www.jensenrvidirect.com](http://www.jensenrvidirect.com)

© 2010 ASA Electronics Corporation

v.022610

## Free Manuals Download Website

<http://myh66.com>

<http://usermanuals.us>

<http://www.somanuals.com>

<http://www.4manuals.cc>

<http://www.manual-lib.com>

<http://www.404manual.com>

<http://www.luxmanual.com>

<http://aubethermostatmanual.com>

Golf course search by state

<http://golfingnear.com>

Email search by domain

<http://emailbydomain.com>

Auto manuals search

<http://auto.somanuals.com>

TV manuals search

<http://tv.somanuals.com>