

JET

EQUIPMENT & TOOLS

OPERATOR'S MANUAL

JDP-20VS-1/3 Drill Press



(JDP-20VS-3 shown)

JET EQUIPMENT & TOOLS, INC.
A WMH - Walter Meier Holding Company

P.O. BOX 1349
Auburn, WA 98071-1349

253-351-6000
Fax 253-939-8001

No. M-354201 1/98

Important Information

**1-YEAR
LIMITED WARRANTY**

**JET offers a one-year limited
warranty on this product**

REPLACEMENT PARTS

Replacement parts for this tool are available directly from JET Equipment & Tools. To place an order, call 1-800-274-6848. Please have the following information ready:

1. Visa, MasterCard, or Discover Card number
2. Expiration date
3. Part number listed within this manual
4. Shipping address other than a Post Office box.

REPLACEMENT PART WARRANTY

JET Equipment & Tools makes every effort to assure that parts meet high quality and durability standards and warrants to the original retail consumer/purchaser of our parts that each such part(s) to be free from defects in materials and workmanship for a period of thirty (30) days from the date of purchase.

PROOF OF PURCHASE

Please retain your dated sales receipt as proof of purchase to validate the warranty period.

LIMITED TOOL AND EQUIPMENT WARRANTY

JET makes every effort to assure that its products meet high quality and durability standards and warrants to the original retail consumer/purchaser of our products that each product be free from defects in materials and workmanship as follows: 1 YEAR LIMITED WARRANTY ON THIS JET PRODUCT. Warranty does not apply to defects due directly or indirectly to misuse, abuse, negligence or accidents, repairs or alterations outside our facilities or to a lack of maintenance. JET LIMITS ALL IMPLIED WARRANTIES TO THE PERIOD SPECIFIED ABOVE FROM THE DATE THE PRODUCT WAS PURCHASED AT RETAIL. EXCEPT AS STATED HEREIN, ANY IMPLIED WARRANTIES OR MERCHANTABILITY AND FITNESS ARE EXCLUDED. SOME STATES DO NOT ALLOW LIMITATIONS ON HOW LONG THE IMPLIED WARRANTY LASTS, SO THE ABOVE LIMITATION MAY NOT APPLY TO YOU. JET SHALL IN NO EVENT BE LIABLE FOR DEATH, INJURIES TO PERSONS OR PROPERTY OR FOR INCIDENTAL, CONTINGENT, SPECIAL OR CONSEQUENTIAL DAMAGES ARISING FROM THE USE OF OUR PRODUCTS. SOME STATES DO NOT ALLOW THE EXCLUSION OR LIMITATION OF INCIDENTAL OR CONSEQUENTIAL DAMAGES, SO THE ABOVE LIMITATION OR EXCLUSION MAY NOT APPLY TO YOU. To take advantage of this warranty, the product or part must be returned for examination, postage prepaid, to an authorized service station designated by our Auburn office. Proof of purchase date and an explanation of the complaint must accompany the merchandise. If our inspection discloses a defect, JET will either repair or replace the product or refund the purchase price, if we cannot readily and quickly provide a repair or replacement, if you are willing to accept such refund. JET will return repaired product or replacement at JET's expense, but if it is determined there is no defect, or that the defect resulted from causes not within the scope of JET's warranty, then the user must bear the cost of storing and returning the product. This warranty gives you specific legal rights, and you have other rights, which vary, from state to state.

JET Equipment & Tools • P.O. Box 1349, Auburn, WA 98071-1349 • (253) 351-6000

 **WARNING**

For your own safety, read the operator's manual before operating the drill press.

Wear eye protection.

Do not wear gloves, neckties, long sleeves, jewelry, or loose clothing that may become caught in moving parts. Long hair must be contained.

Clamp the workpiece or brace it against the column to prevent rotation.

Use the recommended speed for drill accessories and workpiece materials.

This drill press is designed and intended for use by properly trained and experienced personnel only. If you are not familiar with the proper and safe operation of a drill press, do not use until proper training and knowledge has been obtained.

- **KEEP GUARDS IN PLACE** and in working order.
- **KEEP ALL BODY PARTS AWAY FROM MOVING PARTS.** Avoid placing any part of your body near belts, cutters, gears, etc.
- **REMOVE ADJUSTING KEYS AND WRENCHES.** Form a habit of checking to see that keys and adjusting wrenches are removed from the machine before turning it on.
- **KEEP THE WORK AREA CLEAN.** Cluttered areas and work benches invite accidents.
- **DON'T USE IN A DANGEROUS ENVIRONMENT.** Don't use power tools in damp or wet locations, or expose them to rain. Keep work area well lighted.
- **KEEP CHILDREN AWAY.** All visitors should be kept a safe distance from the work area.
- **MAKE THE WORKSHOP KIDPROOF** with padlocks, master swatches, or by removing starter keys.
- **DON'T FORCE THE MACHINE.** It will do the job better and safer at the rate for which it was designed.
- **USE THE RIGHT MACHINE.** Don't force a machine or attachment to do a job for which it was not designed.
- **USE THE PROPER EXTENSION CORD.** Make sure your extension cord is in good condition. When using an extension cord, be sure to use one heavy enough to carry the current your machine will draw. An undersized cord will cause a drop in the line voltage resulting in power loss and overheating. If in doubt, use the next heavier gauge. Remember, the smaller the gauge number, the heavier the cord.
- **WEAR PROPER APPAREL.** Do not wear loose clothing, gloves, neckties, rings, bracelets, or other jewelry which may get caught in moving parts. Non-slip footwear is recommended. Wear protective hair covering to contain long hair.
- **ALWAYS USE SAFETY GLASSES.** Also use face or dust masks if the cutting operation is dusty. Everyday eyeglasses only have impact resistant lenses; they are not safety glasses.
- **DON'T OVERREACH.** Keep proper footing and balance at all times.
- **MAINTAIN TOOLS WITH CARE.** Keep tools sharp and clean for the best and safest performance. Follow instructions for lubricating and changing accessories.

- **ALWAYS DISCONNECT THE MACHINE FROM THE POWER SOURCE BEFORE SERVICING.**
- **REDUCE THE RISK OF UNINTENTIONAL STARTING.** Make sure the switch is in the off position before plugging in.
- **NEVER STAND ON A MACHINE.** Serious injury could occur if the machine tipped or if the drill bit is unintentionally contacted.
- **CHECK DAMAGED PARTS.** Before further use of the machine, a guard or other part that is damaged should be carefully checked to determine that it will operate properly and perform its intended function - check for alignment of moving parts, binding of moving parts, breakage of parts, mounting, and any other conditions that may affect its operation. A guard or other part that is damaged should be properly repaired or replaced.
- **NEVER LEAVE THE MACHINE RUNNING UNATTENDED. TURN POWER OFF.** Don't leave the machine until it comes to a complete stop.

Further reading on these and other safety information can be found in the publication *Safety Requirements for the Construction, Care, and Use of Drilling, Milling, and Boring Machines* (ANSI B11.8 1983) published by The American National Standards Institute. Order this publication from:

The American National Standards Institute
1430 Broadway
New York, New York 10018

ANSI B11.8-1983, Section 5.1 states that "it shall be the responsibility of the employer to provide, and ensure the use of, a guard, guarding device, awareness barrier, awareness device, or shield..." To assist employees and machine users in designing point of operation safeguarding for a specific machine application, the Occupational Safety and Health Administration offers a booklet titled *Concepts and Techniques of Machine Safeguarding* (O.S.H.A. publication #3067). Order this publication from:

The Publications Office – O.S.H.A.
U.S. Department of Labor
200 Constitution Ave, NW
Washington DC 20210

Electrical Instructions

Caution: This tool must be grounded while in use to protect the operator from electric shock.

Note: The JDP-20VS-1 is rated at 115/230V and comes pre-wired at 230V. The JDP-20VS-3 is rated at 230V and cannot be changed.

In the event of a malfunction or breakdown, grounding provides a path of least resistance for electric current to reduce the risk of electric shock. This tool is equipped with an electric cord having an equipment-grounding conductor and a grounding plug. The plug must be plugged into a matching outlet that is properly installed and grounded in accordance with all local codes and ordinances.

Do not modify the plug provided. If it will not fit the outlet, have the proper outlet installed by a qualified electrician.

Improper connection of the equipment-grounding conductor can result in a risk of electric shock. The conductor, with insulation having an outer surface that is green with or without yellow stripes, is the equipment-grounding conductor. If repair or replacement of the electric cord or plug is necessary, do not connect the equipment-grounding conductor to a live terminal.

Check with a qualified electrician or service personnel if the grounding instructions are not completely understood, or if in doubt as to whether the tool is properly grounded. Use only three wire extension cords that have three-prong grounding plugs and three-pole receptacles that accept the tool's plug.

Repair or replace a damaged or worn cord immediately.

Important Information

The JDP-20VS-1 comes pre-wired from the factory at 230V. It is strongly recommended that this drill press be operated at 230V. If, however, you decide to change the operating voltage to 115V, please be advised that the drill press may be hard to start when set at a higher R.P.M. When operating the drill press, lower the R.P.M. to the lowest setting before turning the machine off. This will make starting the machine easier.

115 Volt Operation

Note: The JDP-20VS-1 is rated at 115/230V and comes pre-wired at 230V. The JDP-20VS-3 is rated at 230V only and cannot be changed.

If 115V, single-phase operation is desired; the following instructions must be followed:

1. Disconnect the machine from the power source.
2. This drill press is supplied with four motor leads that are connected for 230V operation, as shown in Figure D. Reconnect these four motor leads for 115V operation, as shown in Figure C.
3. If the drill press is to be fitted with a plug instead of hard-wired, it should only be connected to an outlet having the same configuration as illustrated by the grounded outlet box in Figure E. No adapter is available or should be used with a 230V plug.

Important: In all cases (115 or 230 volts), make certain the receptacle in question is properly grounded. If you are not sure, have a licensed electrician check the receptacle.

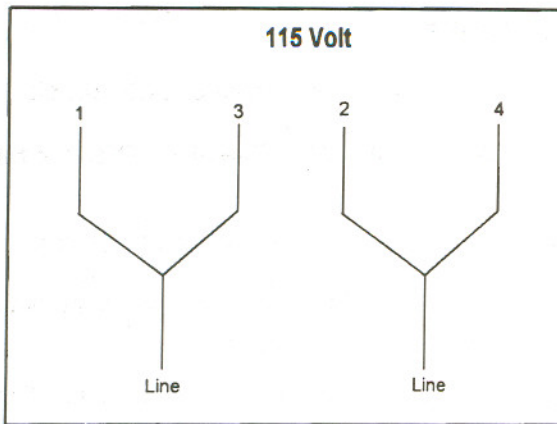

Fig. C

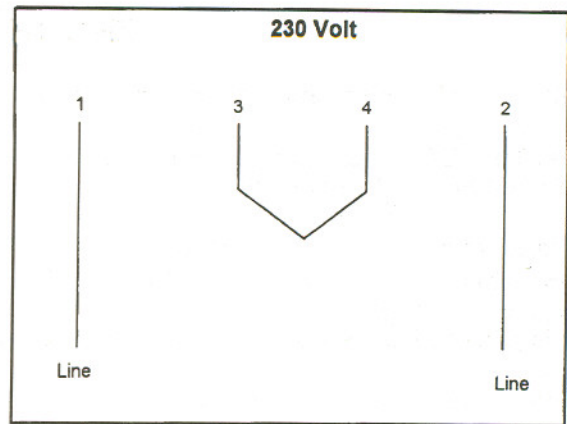

Fig. D

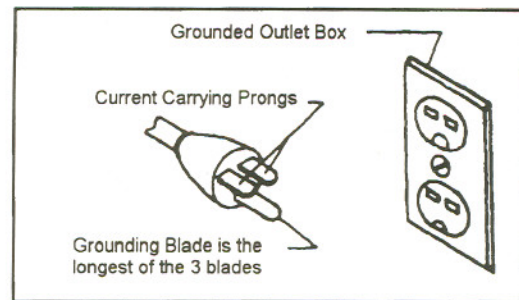

Fig. E

As received from the factory, the JDP-20VS-1 drill press is ready to run at 230 volt operation (the JDP-20VS-3 is 230V and **cannot** be changed). This drill press, when the wiring is changed to 115 volt, is intended for use on a circuit that has an outlet and a plug that looks the one illustrated in Figure A. A temporary adapter, which looks like the adapter as illustrated in Figure B, may be used to connect this plug to a two-pole receptacle, as shown in Figure B if a properly grounded outlet is not available. The temporary adapter should only be used until a properly grounded outlet can be installed by a qualified electrician. **This adapter is not applicable in Canada.** The green colored rigid ear, lug, or tab, extending from the adapter, must be connected to a permanent ground such as a properly grounded outlet box, as shown in Figure B.

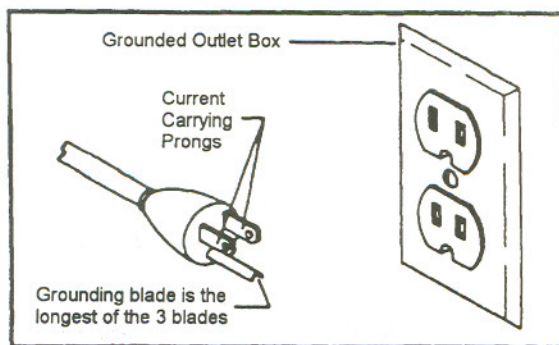

Fig. A

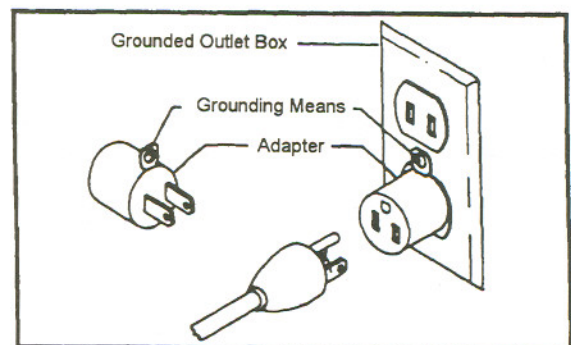

Fig. B

Specifications:	JDP-20VS-1	JDP-20VS-3
Stock Number	354201.....	354203
Drilling Capacity		
Cast Iron (in.).....	1-1/2	1-1/2
Steel (in.).....	1-1/4	1-1/4
Tapping Capacity (in.).....	NA.....	3/4
Column Capacity (in.)	4.....	4
Spindle to Column (maximum – in.)	10.....	10
Spindle Travel (in.).....	6-1/2	6-1/2
Spindle Distance to Table (in.)	28-1/2.....	28-1/2
Table Size (in.).....	22 x 19-1/2.....	22 x 19-1/2
Number of T-Slots.....	2.....	2
T-Slot Size (in.).....	5/8.....	5/8
T-Slot Centers (in.)	8-7/8	8-7/8
Spindle Taper	MT-3	MT-3
Spindle Speeds.....	Variable	Variable
Spindle RPM (approx.)	300-2,000	150-2,000
Motor.....	1-1/2 HP, 1 Ph.....	2 HP, 3 Ph,
.....	115/230V	2-Speed
.....	prewired 230V	230V only
Overall Height (in.).....	69.....	69
Base Size (in.)	26 x 19.....	26 x 19
Table Size (in.).....	20.....	20
Net Weight (approx. – lbs.).....	720.....	740
Shipping Weight (approx. – lbs.)	754.....	774

The specifications in this manual are given as general information and are not binding. JET Equipment and Tools reserves the right to effect, at any time and without prior notice, changes or alterations to parts, fittings, and accessory equipment deemed necessary for any reason whatsoever.

Unpacking and Clean-Up

1. Finish removing the shipping crate.
2. Remove the skid from under the press.
3. Remove the protective coating from all rust protected surfaces with a soft cloth moistened with kerosene or a mild solvent. Do not use acetone, gasoline, or paint thinner. These will damage painted surfaces.
4. To prevent rust, apply a thin coat of paste wax to the table.

Installation

The drill press must be located in a dry, well lighted area with adequate room on all sides of the machine. The floor must be level and the drill press must rest solidly on the floor. The most accurate and vibration free operation will require the drill press to be bolted to the floor. While this is not absolutely necessary, it is highly recommended. Place shims near the three bolt holes to level the drill press, if necessary. Equal pressure should be applied to all three nuts when tightening to prevent distorting the base.

Raising the Head

The drill press head is lowered on the column for crating and transportation. Before operating the drill press, the head will need to be raised to the operational level. To raise the head:

1. Loosen the table lock (A, Fig. 1).
2. Cut a 2" x 4" approximately 16" in length.
3. Raise the table (B, Fig. 1) and place the 2" x 4" between the table and the head (C, Fig. 1) as close the column (D, Fig. 1) as possible. Caution: Do not place the 2" x 4" under the lock collar (E, Fig. 1).
4. Using the table lift crank (F, Fig. 1), raise the head until the head bore and the column are flush. Use a ladder to observe the column through the top of the belt cover.

⚠ WARNING
Do not raise the head any farther or it may fall off the column!
Failure to comply may cause damage to property and/or bodily injury!

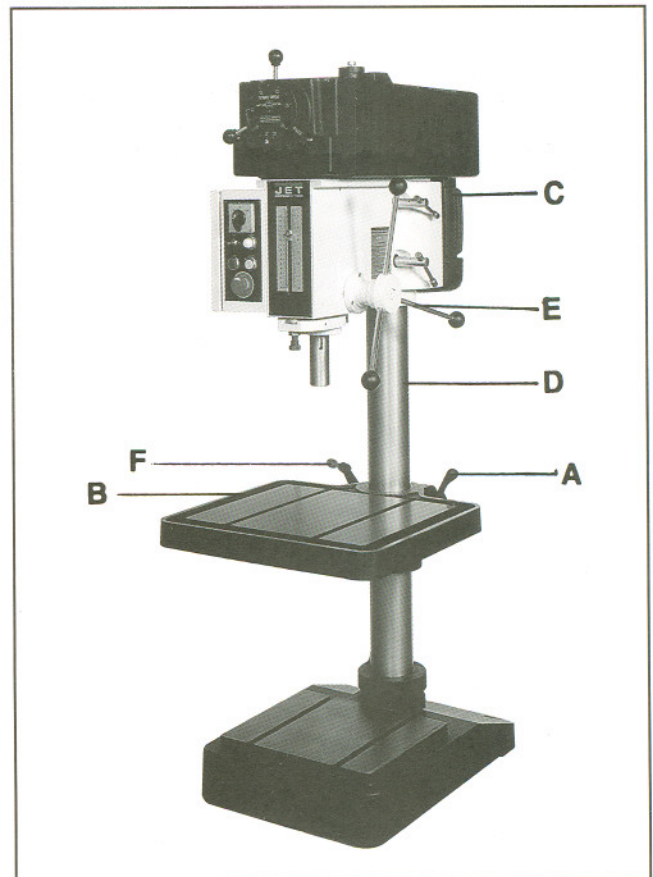

Fig. 1

5. Tighten the two head locking bolts (A, Fig. 2). This will hold the head in place until the lock collar can be moved into position. The 2" x 4" can now be safely removed.
6. After the head is set at the desired height, loosen two set screws (B, Fig. 2) on the lock collar.
7. Slide the lock collar up the column until it is flush with the head.
8. Firmly tighten two set screw (B, Fig. 2).

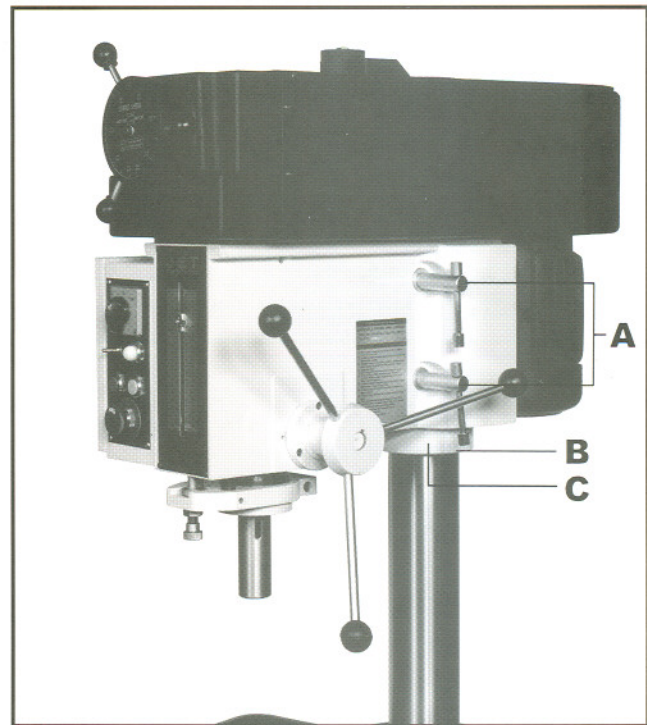

Fig. 2

Raising the Rack

Some drilling operations will require the table to be moved closer to the spindle than the rack will allow as set by the factory. To raise the rack:

1. Tighten the table lock handle (A, Fig. 3).
2. Loosen two set screws (A, Fig. 4) on the column bearing collar (B, Fig. 4). Caution: Do not loosen two set screws (C, Fig. 4) with lock nuts.
3. Raise the rack (B, Fig. 3) to the desired level by turning the table raising handle (C, Fig. 3).
4. Tighten the two set screws (A, Fig. 4) to keep the rack in position. Now the table can be raised to the desired position.

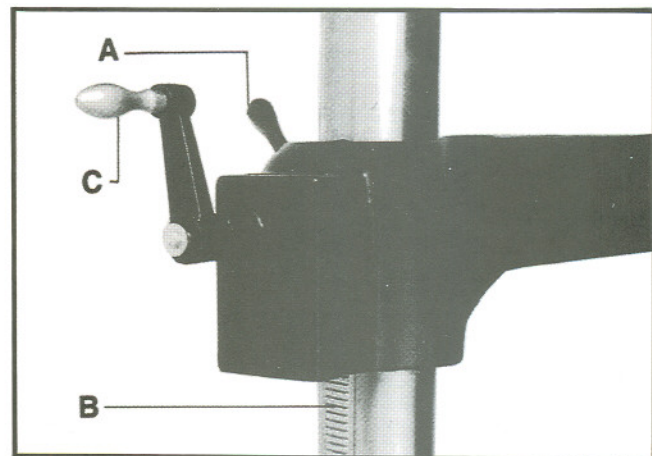

Fig. 3

Control Panel – JDP-20VS-3

High-Low Switch (A, Fig. 5) – the center position is neutral. Turn to the right to select the low motor speed. Turn to the left to select the high motor speed.

Drill Tap Switch (B, Fig. 5) – the center position is the off position. Push the switch to the left for the drill function. Push the switch the right for the tap function.

Power Indicating Lamp (C, Fig. 5) – indicates power to the main panel when lit. This lamp will only light up in the drill or tap mode.

Motor Start Button (D, Fig. 5) – activates the motor in the drill or tap mode.

Tap Return Button (E, Fig. 5) – reverses the spindle rotation and the tap withdraws. Works only in the tap mode.

Emergency Stop Button (F, Fig. 5) – disconnects the power to the motor. Reset the button by turning 90°.

Control Panel – JDP-20VS-1

On-Off Switch – turns power to the machine on and off.

Changing Spindle Speeds

Caution

Do not turn the hand wheel speed control unless the motor is running! The speed control linkage may be damaged if the motor is not running!

To change spindle speeds, turn the hand wheel (A, Fig. 6) until the pointer shows the desired speed. Speeds are approximate.

Adjusting the Depth Stop for Drilling

Adjust the zero reading on the scale by:

1. Lower the quill to the bottom of its stroke by turning the handle (A, Fig. 7) counter-clockwise until it stops and hold in that position.
2. Turn the knurled knob (B, Fig. 7) until the pointer reads zero.
3. To set the depth stop, turn the knurled knob (B, Fig. 7) to the desired setting. The quill will now only advance to this setting.

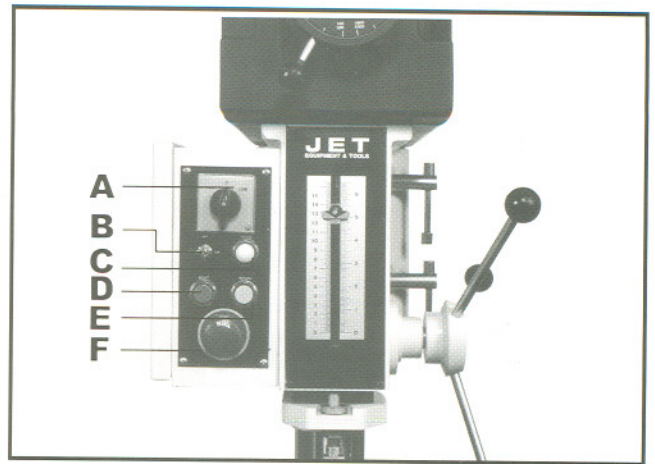

Fig. 5

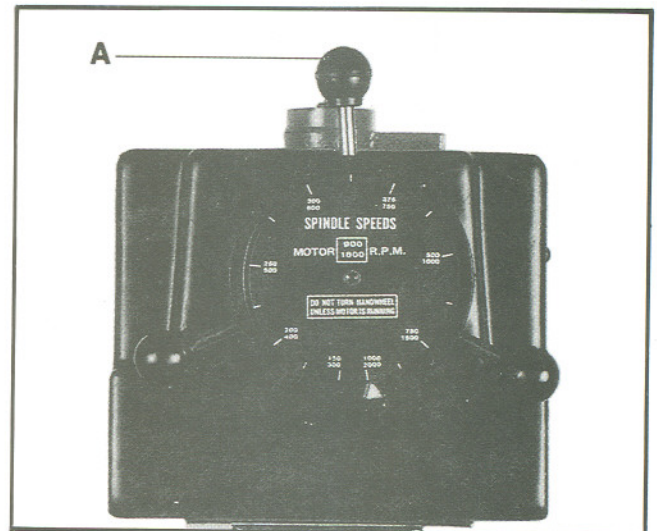

Fig. 6

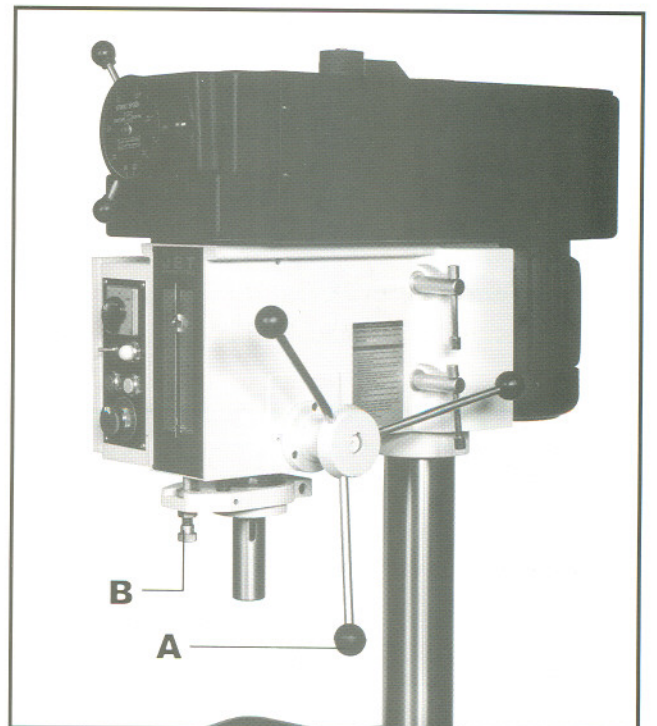

Fig. 7

Adjusting the Depth Stop for Tapping

(JDP-20VS-3 only)

To adjust the depth stop for tapping, follow the instructions for adjusting the depth stop for drilling. The major differences in the tap mode are two micro-switches. One micro-switch automatically reverses (counter-clockwise) the spindle direction at a predetermined depth. The other micro-switch forwards (clockwise) the direction of the spindle once it is fully retracted.

Spindle Preparation

Thoroughly clean the inside of the spindle with a soft dry cloth. Also clean any taper or arbor to be used in the spindle. If these are not kept clean, the taper or arbor will not "seat" properly in the spindle and may drop out unexpectedly.

Installing Drill Chuck Arbors or Taper Drill Bits

1. Disconnect the machine from the power source.
2. Make sure the spindle bore and the arbor or drill bit is clean.
3. Place a protective piece of scrap wood on the table.
4. Raise the table to approximately 8" to 10" below the spindle.
5. Insert the Morse Taper 3 taper bit or chuck arbor into the spindle. If the taper bit or chuck arbor has a tang, turn the bit or arbor until the tang engages the slot inside the spindle.
6. Lower the spindle with the handle assembly and seat the taper bit or chuck arbor with pressure on the handle assembly.

Removing Taper Drills or Chuck Arbors

1. Disconnect the machine from the power source.
2. Place a protective piece of scrap wood on the table.
3. Raise the table to approximately 8" to 10" below the spindle.
4. Lower the spindle to expose the slots in the spindle wall.
5. Insert the drift key into one of the spindle slots and tap gently until the drill bit or chuck arbor loosens and falls out

Drill Speed Chart

Use the following drill speed charts to determine the approximate drill speed for the size bit and type of material to be drilled. Speeds are listed in revolutions per minute.

Drill Diameter (in.)	1/16	3/32	1/8	5/32	3/16	7/32	1/4	9/32
Soft Wood	3000	3000	3000	3000	3000	3000	3000	2180
Hard Wood	3000	3000	3000	3000	3000	3000	3000	2180
Plastic/Rubber	3000	3000	3000	3000	3000	3000	3000	2180
Cast Iron	3000	2180	2180	2180	1450	1450	1280	1090
Soft Metals	3000	3000	3000	3000	3000	3000	3000	3000
Mild Steel	3000	3000	3000	2180	1450	1280	1280	1280
Hard Steel	2180	1820	1280	1090	650	650	590	540

Drill Diameter (in.)	5/16	11/32	3/8	13/32	7/16	15/32	1/2	9/16	5/8
Soft Wood	2180	2180	2180	2180	2180	2180	2180	1820	1820
Hard Wood	2180	2180	2180	2180	2180	2180	1820	1820	1820
Plastic/Rubber	2180	1450	1280	1280	1090	1090	1090	650	650
Cast Iron	650	650	650	650	650	650	590	540	410
Soft Metals	3000	3000	3000	3000	2180	2180	2180	2180	2180
Mild Steel	1280	1090	1090	650	650	650	590	590	590
Hard Steel	410	410	410	360	250	250	250	250	250

Lubrication

Location	Type	Frequency
Spindle splines in the spindle pulley drive	#2 lithium based tube grease	Weekly
Quill and column	Machine tool oil	Daily
Lift rack	20W non-detergent oil	Weekly (clean rack with kerosene before lubricating)
Table lift	Gear grease	Twice yearly (clean and repack)

Variable Drive Lubrication

Location	Type	Frequency
Speed control fork	Molybdenum based grease	Weekly
Counter shaft spindle (upper end)	20W non-detergent	Daily
Hand wheel cam	#2 lithium based grease	Twice yearly

JDP-20VS-1/3 Head Assembly

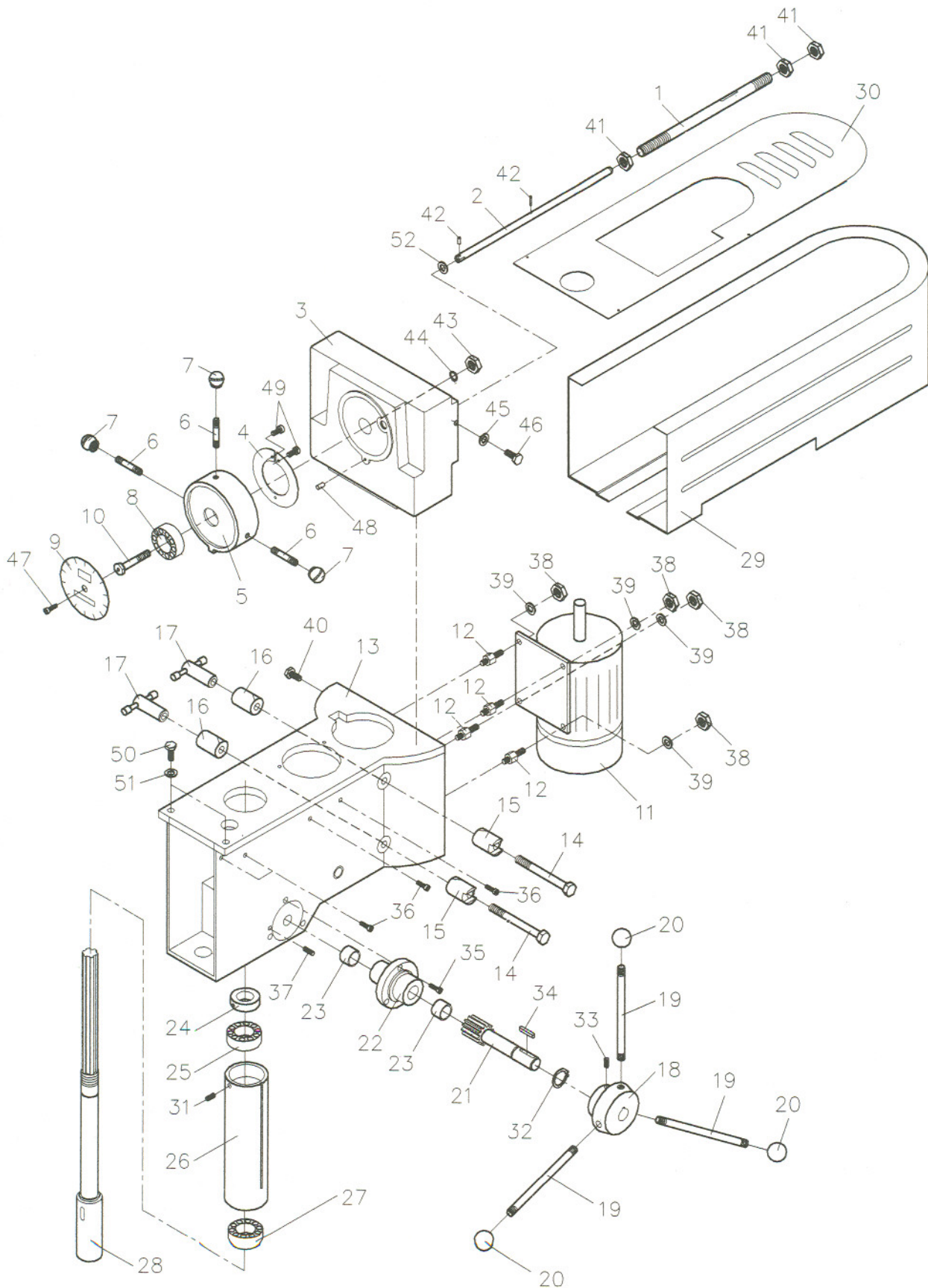

JDP-20VS-1/3 Head Assembly

Index No.	Part No.	Description	Size	Qty.
1	70-1507	Push Rod Tube		1
2	70-1509	Push Rod		1
3	70-1508	Spindle Cover		1
4	70-1516	Cam Spring		1
5	70-1512	Hub		1
6	70-1515	Handle		3
7	70-1515-1	Ball		3
8	A-632	Ball Bearing		1
9	71-1610	Speed Dial		1
10	70-1513	Bolt		1
11	70-1901	Motor (JDP-20VS-1 only)	1-1/2 HP, 1Ph	1
	70-1903	Motor (JDP-20VS-3 only)	2HP, 3Ph	1
12	71-1009	Motor Mount Bolt		4
13	71-1001B	Head		1
14	70-1026B	Lock Screw		2
15	70-1019B	Head Lock		2
16	70-1020B	Head Lock		2
17	70-1022	Lock Handle		2
18	70-1407B	Hub		1
19	70-1408	Handle		3
20	70-1408-1	Ball		3
21	70-1401B	Pinion		1
22	71-1402B	Pinion Support		1
23	71-1402-1	Bushing		2
24	71-1004B	Nut		1
25	BB-6206Z	Ball Bearing		1
26	71-1003B	Quill		1
27	BB-5206	Ball Bearing		1
28	71-1002B	Spindle		1
29	70-1014	Belt Cover		1
30	70-1014-1	Top Plate		1
31	TS-0267031	Set Screw	1/4 x 5/16	1
32	JDP20VS-32	Snap Ring	R25	1
33	TS-0270021	Set Screw	5/16 x 5/16	1
34	JDP20VS-34	Key	6 x 6 x 30	1
35	JDP20VS-35	Pan Head Screw	1/4 x 3/4	3
36	JDP20VS-36	Pan Head Screw	1/4 x 1/2	4
37	TS-0270101	Set Screw	5/16 x 1-1/4	2
38	TS-0561031	Hex Nut	3/8	4
39	TS-0680041	Washer	3/8	4
40	TS-0051011	Hex Cap Bolt	5/16 x 1/2	2
41	TS-0561072	Hex Nut	5/8-18UNF	3
42	JDP20VS-42	Pin	3 x 18	2
43	TS-0561052	Hex Nut	1/2-20UNF	1
44	TS-0720111	Spring Washer	1/2	1
45	TS-0680041	Washer	3/8	1
46	TS-0051051	Hex Cap Bolt	5/16 x 1	2
47	JDP20VS-47	Hex Socket Cap Screw	1/4 x 1/4	1
48	JDP20VS-48	Pin	5 x 20	1

JDP-20VS-1/3 Head Assembly (continued)

49	JDP20VS-49	Screw	3/16 x 3/8	3
50	TS-0061041	Hex Cap Bolt	7/16 x 1-1/4	3
51	TS-0680051	Spring Washer	7/16	2
52	JDP20VS-52	Washer		1

JDP-20VS-1/3 Variable Speed Assembly

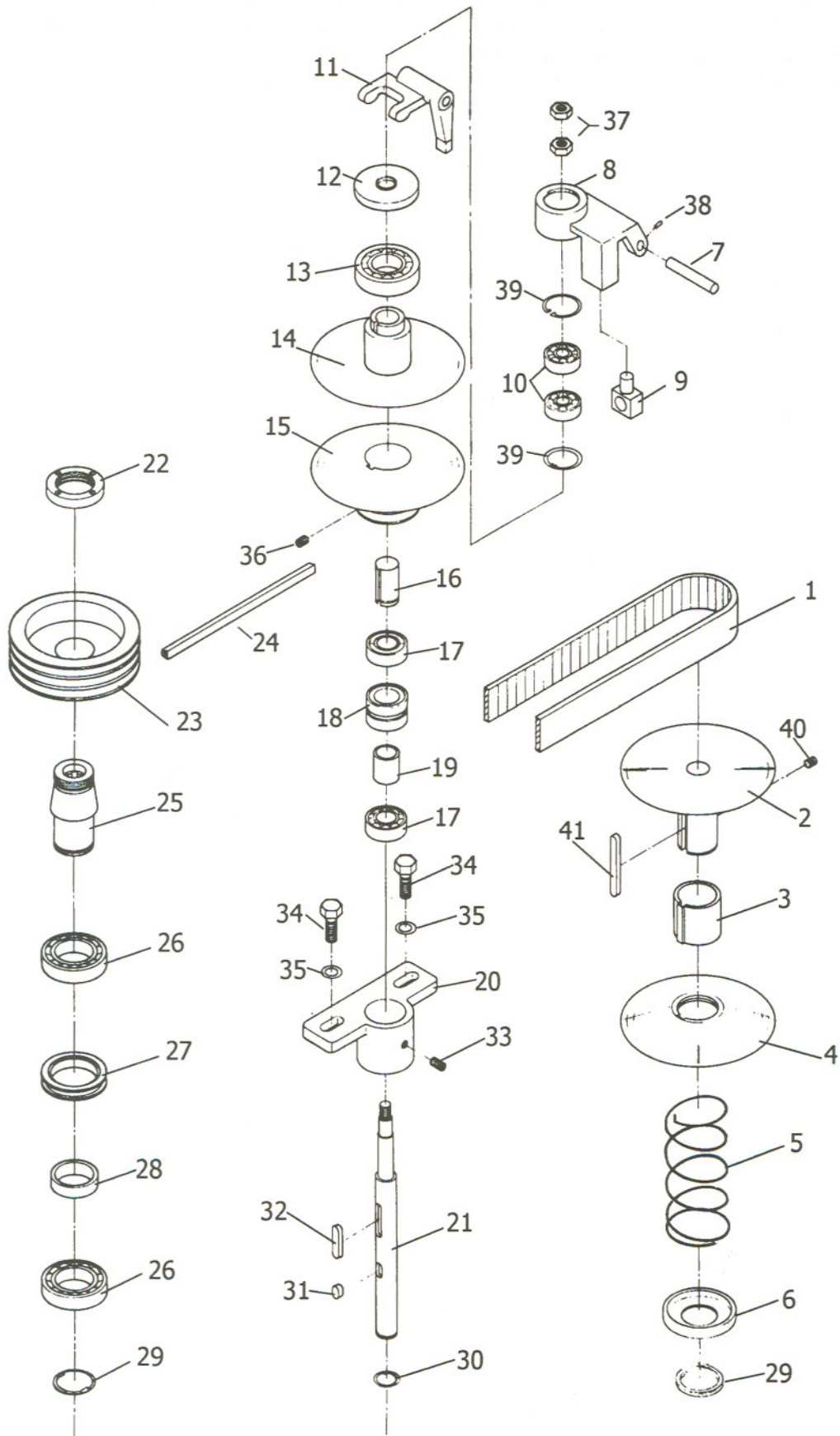

JDP-20VS-1/3 Variable Speed Assembly

1	70-1206	V-Belt	VB-1926V427	1
2	70-1211	Upper Motor Pulley		1
3	70-1023	Motor Pulley Sleeve		1
4	70-1210	Lower Motor Pulley		1
5	70-1024	Pulley Spring		1
6	70-1212	Spring Housing		1
7	70-1505	Hinge Pin		1
8	70-1502	Spindle Control Support		1
9	70-1504	Support Swivel		1
10	BB-6302Z	Ball Bearing		2
11	70-1501	Speed Control Fork		1
12	70-1506	Bearing Cup		1
13	BB-6207Z	Ball Bearing		1
14	70-1012	Upper Variable Speed Pulley		1
15	70-1011	Lower Variable Speed Pulley		1
16	70-1010	Spindle Pulley Sleeve		1
17	BB-6205Z	Ball Bearing		2
18	70-1016	Control Shaft Spindle		1
19	70-1017	Sleeve		1
20	70-1018	Bearing Housing		1
21	70-1015	Control Shaft Spindle		1
22	70-1009	Nut		1
23	70-1007	Spindle Pulley		1
24	VB-A25	V-Belt		3
25	70-1008	Spindle Driver		1
26	BB-6009Z	Ball Bearing		2
27	70-1006	Bearing Spacer Sleeve		1
28	70-1021	Bearing Inner Sleeve		1
29	JDP20VS-29	Clip	S45	2
30	JDP20VS-30	Clip	S24	1
31	JDP20VS-31	Key	4.75 x 10 x 10	1
32	JDP20VS-32A	Key	4.75 x 10 x 38	1
33	TS-0267031	Set Screw	1/4 x 5/16	1
34	TS-0061041	Hex Cap Bolt	7/16 x 1-1/4	2
35	TS-0680051	Washer	7/16	2
36	TS-0267031	Set Screw	1/4 x 5/16	1
37	TS-0561042	Hex Nut	7/16-20UNF	2
38	JDP20VS-38	Pin	3 x 18	1
39	JDP20VS-39	Clip	R42	2
40	TS-0270021	Set Screw	5/16 x 5/16	1
41	JDP20VS-41	Key	5.3 x 10 x 48	1

JDP-20VS-1/3 Column, Table, and Base Assembly

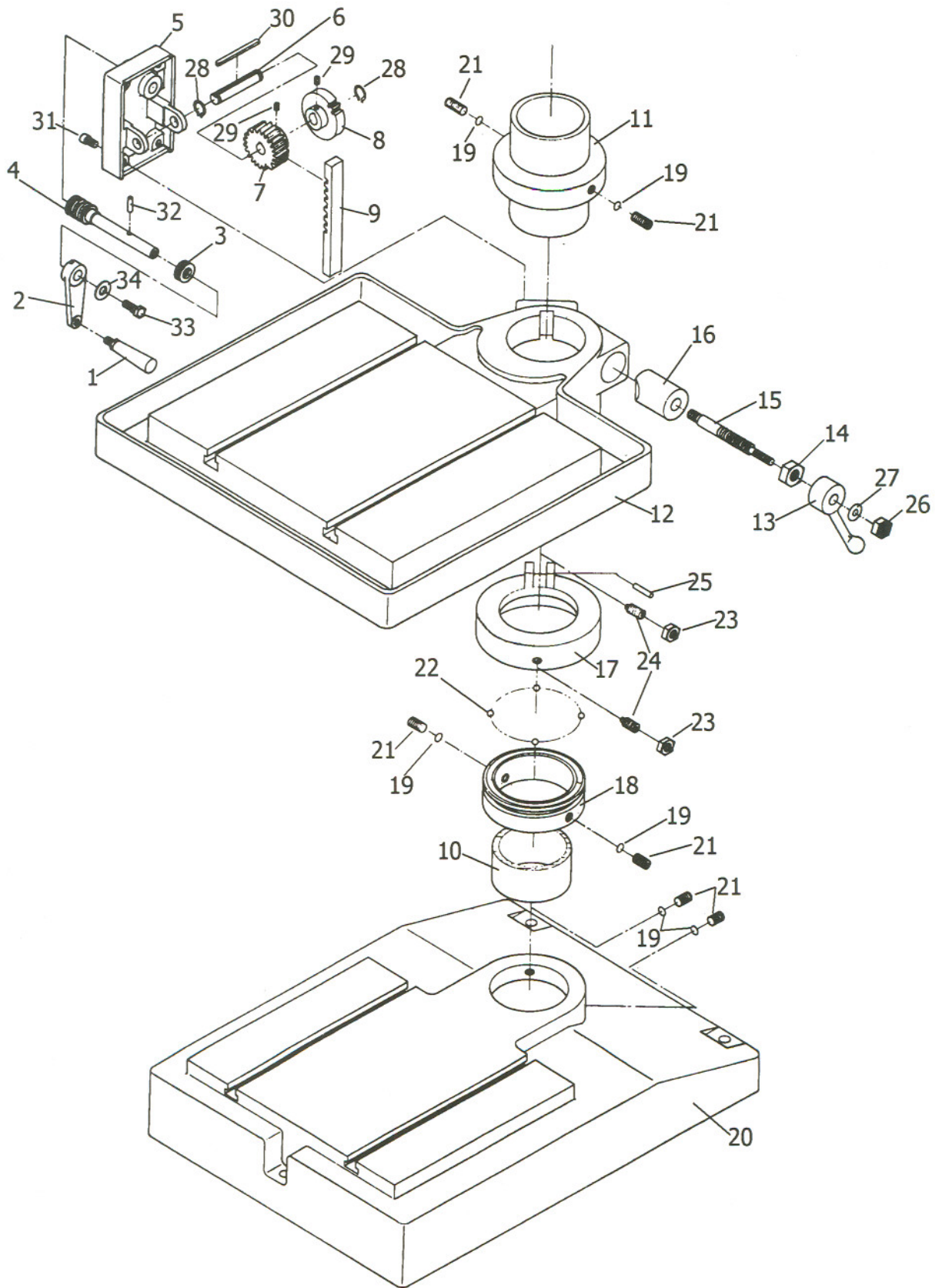

JDP-20VS-1/3 Column, Table, and Base Assembly

1	70-3008	Handle		1
2	70-1306	Lift Crank		1
3	BB-51102	Thrust Bearing		1
4	70-1302	Worm Shaft		1
5	71-1301	Gear Box		1
6	70-1305	Worm Gear Shaft		1
7	71-1302	Gear		1
8	70-1303	Worm Gear		1
9	71-3003	Gear Rack		1
10	71-3005	Column		1
11	70-1008	Collar		1
12	71-2001	Table		1
13	71-2005	Lock Handle		1
14	71-2004	Table Lock Nut		1
15	71-2003	Table Lock Screw		1
16	71-2002	Table Lock		1
17	70-2005	Bearing Ring		1
18	70-2004	Collar		1
19	70-2006	Bushing		6
20	71-3001	Base		1
21	TS-0272021	Set Screw	7/16 x 7/16	6
22	SB-3/8	Steel Ball		39
23	TS-0561021	Hex Nut	5/16	2
24	TS-0270091	Set Screw	5/16 x 1	2
25	JDP20VS-25	Pin	4 x 40	1
26	TS-0561031	Hex Nut	3/8	1
27	TS-0680041	Washer	3/8	1
28	JDP20VS-28	Clip	R15	2
29	TS-0267021	Set Screw	1/4 x 1/4	2
30	JDP20VS-30A	Key	5 x 5 x 40	1
31	TS-0208081	Hex Socket Cap Screw	5/16 x 1-1/2	4
32	JDP20VS-32B	Pin	6 x 30	1
33	TS-0208021	Hex Socket Cap Screw	5/16 x 1/2	1
34	TS-0680031	Washer	5/16	1

JDP-20VS-1/3 Depth Stop and Control Box Assembly

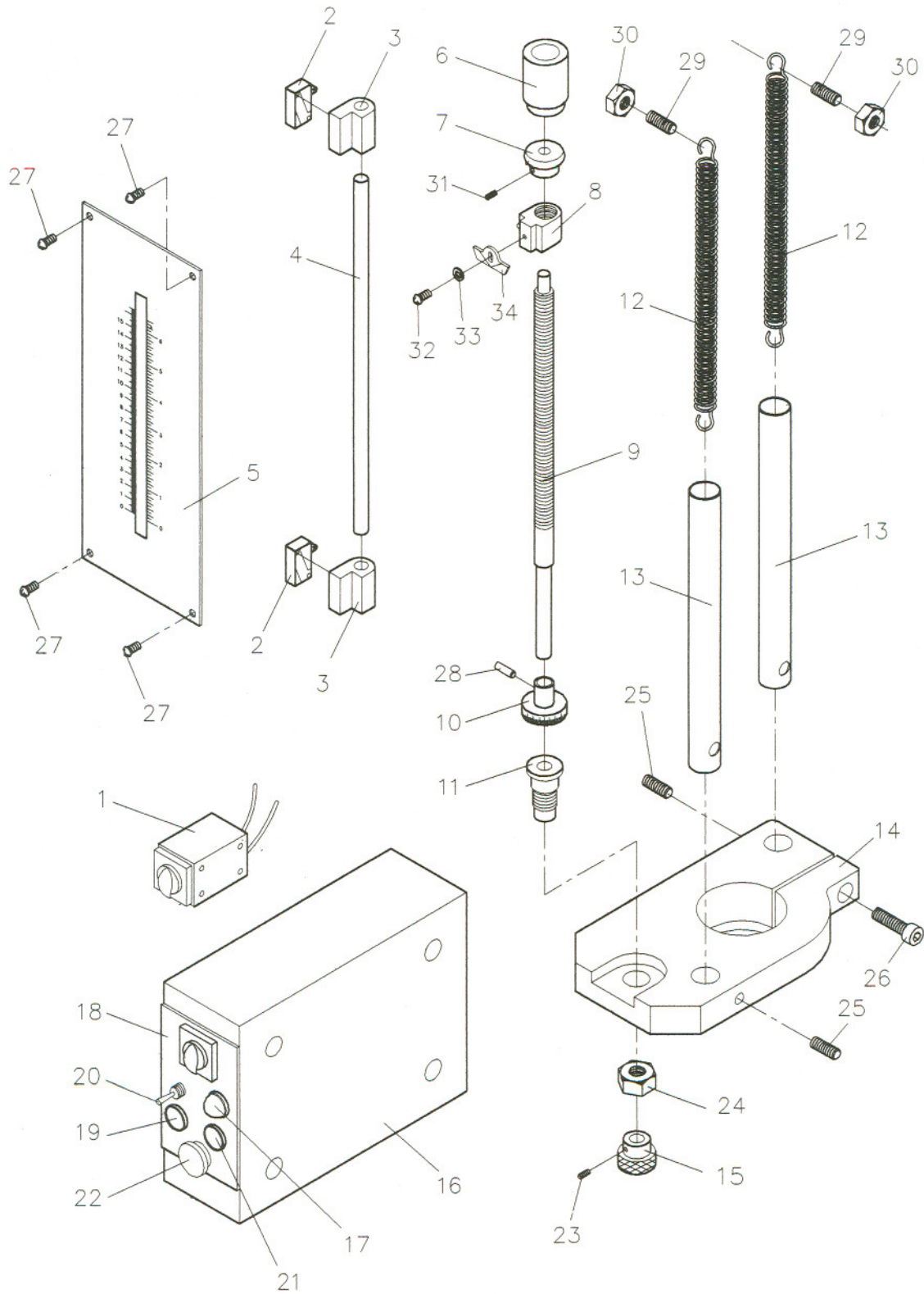

JDP-20VS Depth Stop and Control Box Assembly

1	71-1601	On-Off Switch (JDP-120VS-1 only)	1
2	70-17630	Limit Block	2
3	71-1704	Limit Support	2
4	71-1703	Limit Guide	1
5	70-1611B	Scale	1
6	70-1612B	Stroke Stop Bracket	1
7	71-1706	Tapping Control Nut	1
8	50-1610	Depth Indicator	1
9	70-1606B	Screw	1
10	50-1606	Micro-Dial	1
11	50-1615	Screw Support	1
12	70-1404B	Spring	2
13	70-1410B	Spring Protector	2
14	71-1609B	Bracket	1
15	50-1607	Knob	1
16	71-1701	Control Box (JDP-20VS-3 only)	1
	JDP-20VS-3CB	Control Box Complete (JDP-20VS-3 only)	1
17	E-001	Power Indicator Light (JDP-20VS-3 only)	1
18	E-101	High-Low Switch (JDP-20VS-3 only)	1
19	E-102	Start Button (JDP-20VS-3 only)	1
20	E-103	Drill-Tap Switch	1
21	E-104	Return Switch	1
22	E-106	Emergency Stop Switch	1
23	JDP20VS-23	Pin	3 x 20
24	TS-0561072	Hex Nut	5/8-18UNF
25	TS-0270101	Set Screw	5/16 x 1-1/4
26	TS-0208071	Hex Socket Cap Screw	5/16 x 1-1/4
27	JDP20VS-27	Screw	3/16 x 1/2
28	JDP20VS-28A	Pin	3 x 12
29	TS-0270111	Set Screw	5/16 x 1-1/2
30	TS-0561021	Hex Nut	5/16
31	TS-0267021	Set Screw	1/4"x1/4"
32	JDP-20VS-32	Round Head Screw	M3x0.5
33	TS-0680011	Washer	1/4"
34	JDP-20VS-34	Limite Plate	1

Electrical Panel Components (JDP-20VS-3)

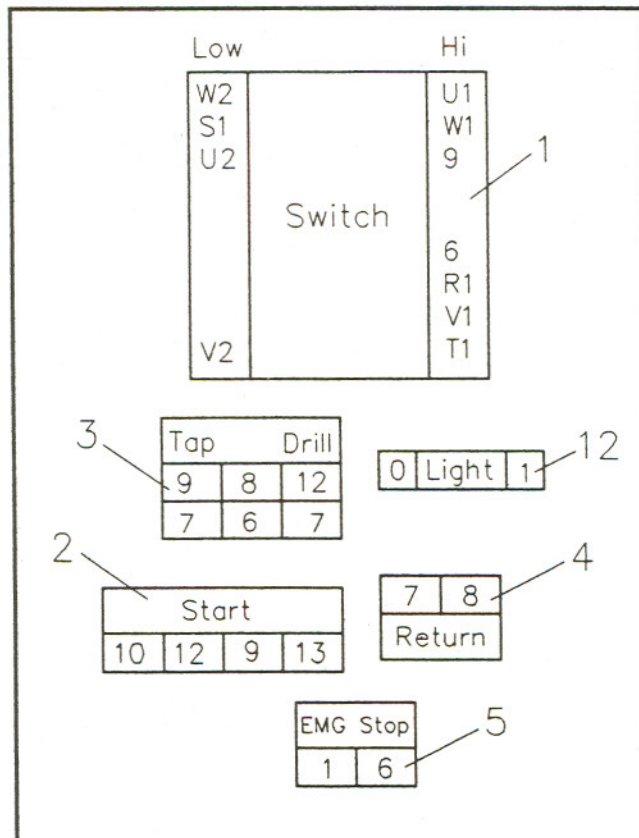
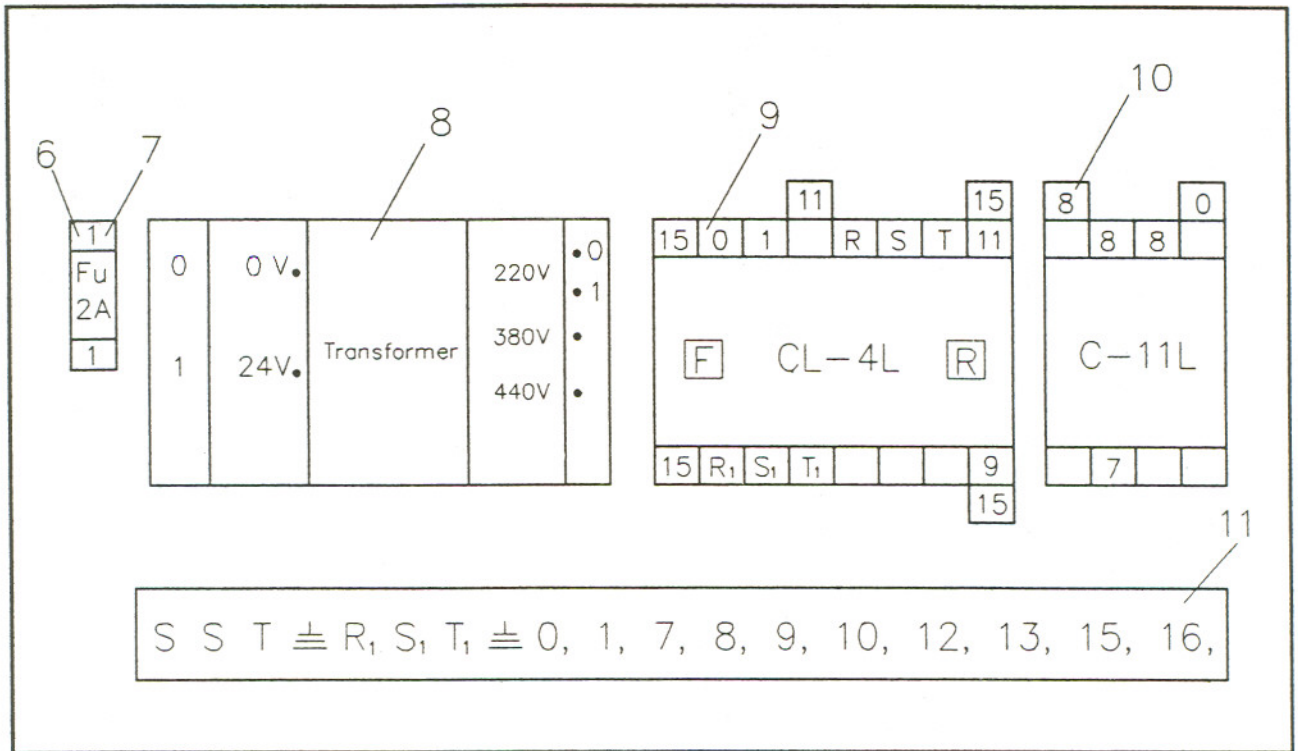

Electrical Panel Components (JDP-20VS-3 only)

1	E-101	High-Low Switch	1
2	E-102	Start Button	1
3	E-103	Drill-Tap Switch	1
4	E-104	Return Switch	1
5	E-106	Emergency Stop Switch	1
6	E-013	Fuse(2AMP)	1
7	E-014	Fuse Seat	1
8	E-111	Transformer	1
9	E-016	Magnetic Starter (CL-4L)	1
10	E-015	Magnetic Starter (C-11L)	1
11	E-110	Terminal Relay	1
12	E-001	Light(24v)	1

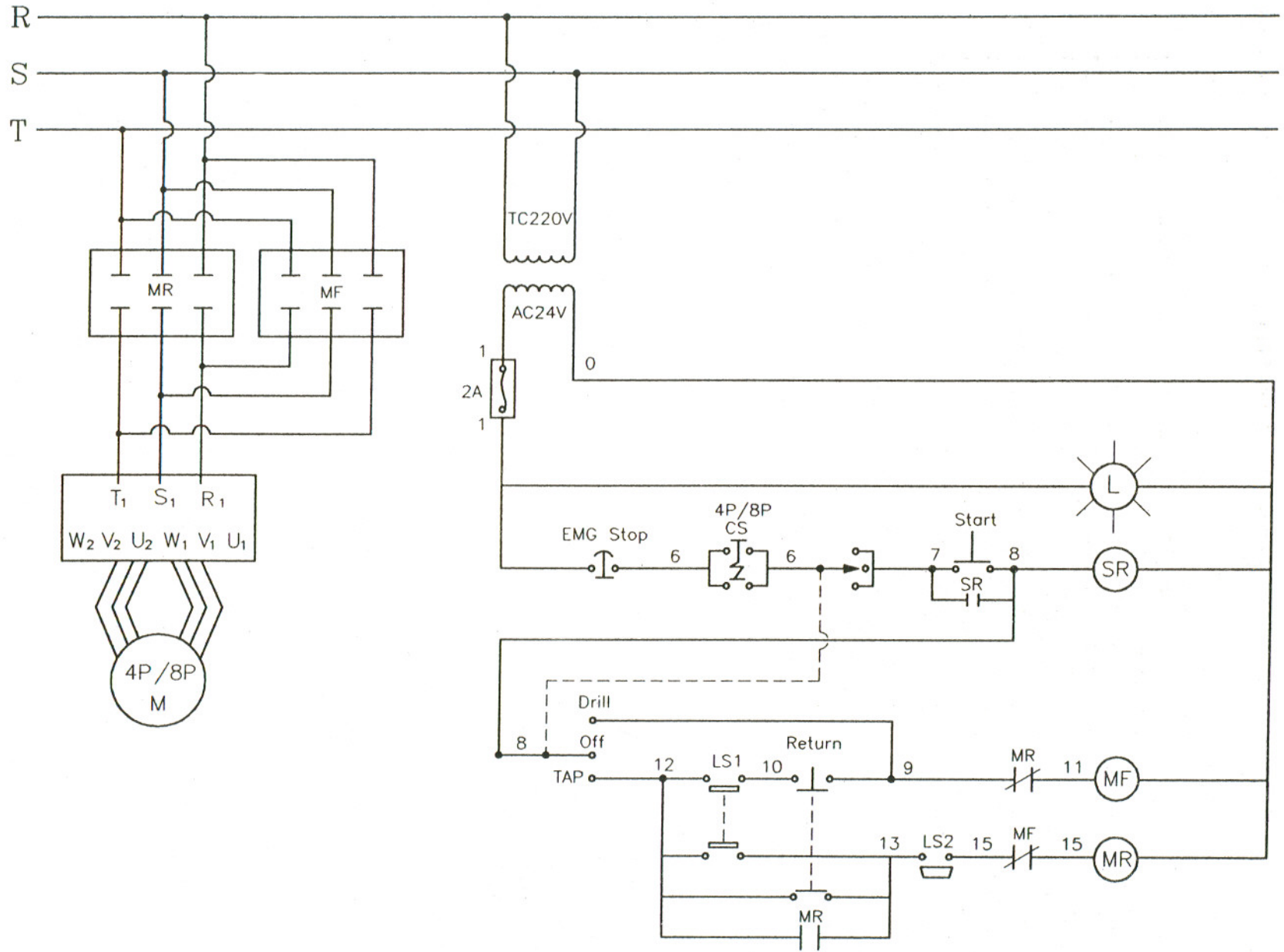

Free Manuals Download Website

<http://myh66.com>

<http://usermanuals.us>

<http://www.somanuals.com>

<http://www.4manuals.cc>

<http://www.manual-lib.com>

<http://www.404manual.com>

<http://www.luxmanual.com>

<http://aubethermostatmanual.com>

Golf course search by state

<http://golfingnear.com>

Email search by domain

<http://emailbydomain.com>

Auto manuals search

<http://auto.somanuals.com>

TV manuals search

<http://tv.somanuals.com>