

OPERATOR'S MANUAL

DEBRIS BLOWER

BL1130

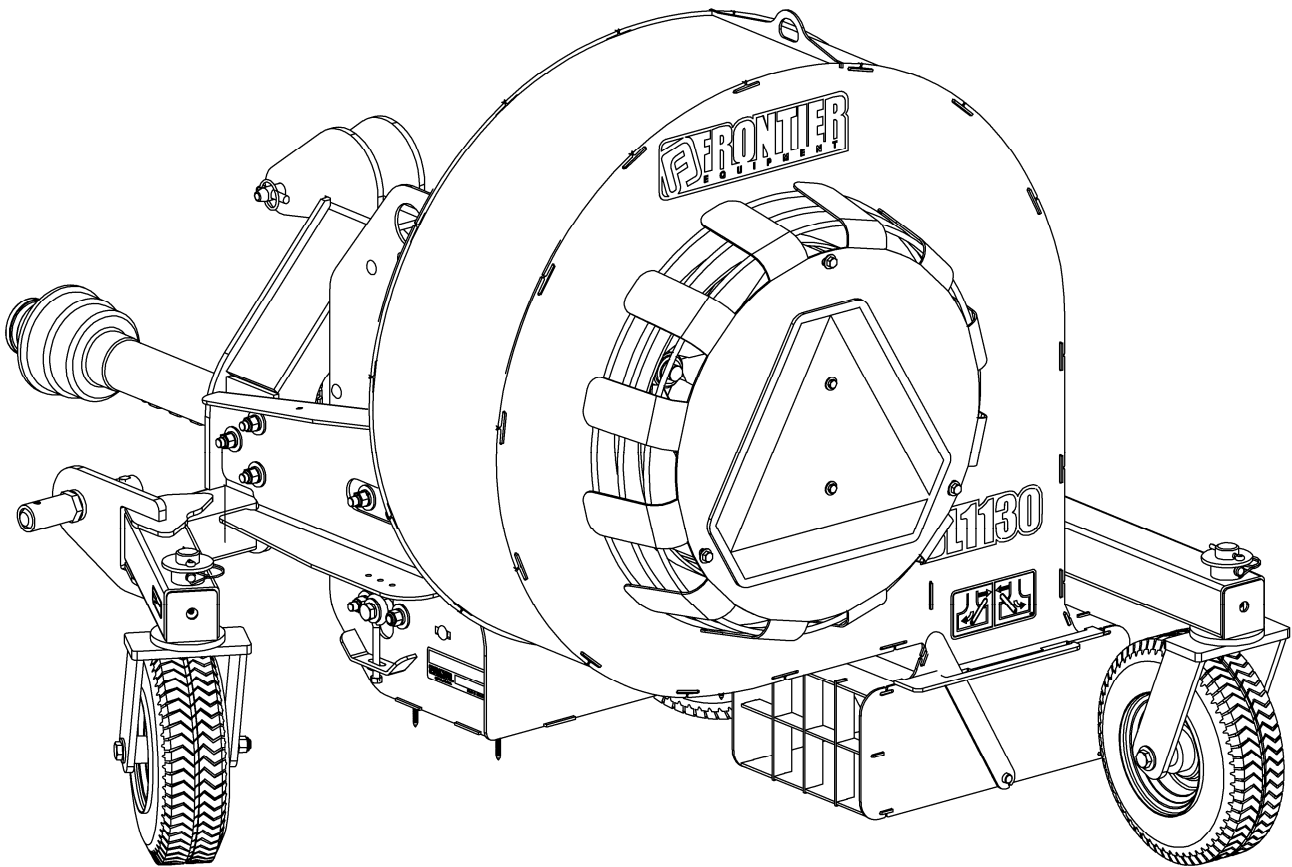

FRONTIER
EQUIPMENT™

OM 0400-A
01/11

TABLE OF CONTENT

SPECIFICATIONS.....	3
INTRODUCTION – TO THE PURCHASER.....	4
SECURITY	5-9
Before Operation	5
Notice	6
Debris Blower	6
Before Operation.....	6
Debris blower Operation	7
The Tractor	8
General Information	8
Operating the Tractor.....	8
During Operation.....	8
Maintenance	9
Transportation	9
Storage	9
DECALS	10
ASSEMBLY.....	11-18
Tractor Preparation	11
Debris Blower Assembly.....	11
Debris Blower removing front wooden crate	11
Debris Blower Installation on a Three Point Hitch.....	12
Installation of the Debris Blower with a Quick Hitch Cat. 1.....	13
Installation of the Debris Blower with a Quick Hitch Cat. 2.....	13
Driveline Preparation.....	14
How To Determine Driveline Angles.....	14
Angles at Each End Of Driveline	15
Determining Driveline Length.....	15-16
Driveline Installation.....	17
Removing Debris Blower from Tractor.....	18

TABLE OF CONTENT

OPERATION	19-21
General Preparation	19
Roadway Transport	19
OPERATION	20
Debris Blower Commands	20
Debris Blower Utilisation.....	20
Nozzle air ejection Orientation	20
Adjustments	21
Reduction Chain Tension Adjustment	21
MAINTENANCE.....	22-28
Maintenance	22
Shear Bolt.....	22
Lubrication.....	23
Periodic Checks	23
Belt Replacement.....	24
Impeller Removing and Reinstallation.....	25
Driveline Troubleshooting.....	26-28
PARTS	29-35
Introduction	29
Manual Holder.....	29
Debris Blower – Housing	30
Debris Blower – Drum.....	31
Debris Blower – Belt Drive.....	32-33
Debris Blower – Hitch and Wheels.....	34
Driveline 5RD4700159	35
TORQUE SPECIFICATION TABLE	36

SPECIFICATION

Features and Specifications	BL1130
Power source	30HP tractor – PTO 540 rpm 25 HP PTO
Category Compatibility 3 point	Standard cat.1 & cat.2
Quick Hitch Compatibility	ASABE Compatible Cat. 1 & 2
Air flow	6061 cfm
Impeller dimension	29 3/4" x 10" – 12 blades
Impeller speed	1453 rpm to 540 rpm
Air velocity	141 m/h – 227 km/h
Outlet area	70.4 cu.in – 454.2 cu.cm
Drive	Belt 4-5VX560 "power band"
Driveline	40 series
Directional control	Manual Panel – left or right
Ground clearance	3 1/8"
Height adjustment	Determined by tractor
Caster wheel	3 wheels – 12" dia. X 3" pneumatic
Impeller housing	Rear & front panel: 10ga Housing edge : 12ga
Dimension	46 1/2" length x 48 1/2" height x 49 1/4" width
Weight	655 lbs

INTRODUCTION

TO THE PURCHASER

All products are designed to give safe, dependable service if they are operated and maintained according to instructions.

Read and understand this manual before operation.

This manual has been prepared to assist the owner and operators in the safe operation and suitable maintenance of the implements. The information was applicable to products at the time of manufacture and does not include modifications made afterwards.

Read and understand this operator's manual before attempting to put an implement into service. Familiarize yourself with the operating instructions and all the safety recommendations contained in this manual and those labeled on the implements and on the tractor. Follow the safety recommendations and make sure that those with whom you work follow them.

Illustrations

The illustrations may not necessarily reproduce the full detail and the exact shape of the parts or depict the actual models, but are intended for reference only.

Direction Reference

Right Hand and Left Hand are determined by those seen by the conductor standing behind the equipment.

The Dealer is responsible for warranty registration of the unit you have purchased. To assist your dealer in handling your needs, please record hereafter the model number and serial number of your implement and tractor. It is also advisable to supply them to your insurance company. It will be helpful in the event that an implement or tractor is lost or stolen.

TRACTOR

DEBRIS BLOWER

MODEL :

SERIAL NUMBER :

DATE OF PURCHASE :



SECURITY



SAFETY FIRST

This symbol, the industry's "Safety Alert Symbol", is used throughout this manual and on labels on the machine itself to warn of the possibility of personal injury. Read these instructions carefully. It is essential that you read the instructions and safety regulations before you attempt to assemble or use this unit.



DANGER : Indicates an imminently hazardous situation which, if not avoided, will result in death or serious injury.



WARNING : Indicates a potentially hazardous situation which, if not avoided, could result in death or serious injury.



CAUTION : Indicates a potentially hazardous situation which, if not avoided, may result in minor or moderate injury.

IMPORTANT : Indicates that equipment or property damage could result if instructions are not followed.

NOTE : Gives helpful information.

All products are designed to give safe, dependable service if they are operated and maintained according to instructions. **Read and understand this manual before operation.** It is the owner's responsibility to be certain anyone operating this product reads this manual, and all other applicable manuals, to become familiar with this equipment and all safety precautions. Failure to do so could result in serious personal injury or equipment damage. If you have any questions, consult your dealer.

BEFORE OPERATION

Children and Bystanders

Tragic accidents can occur if the operator is not alert to the presence of children. Children are generally attracted to machines and the work being done. Never assume children will remain where you last saw them.

1. Keep children out of the operating area and under the watchful eye of another responsible adult.
2. Be alert and turn machine off if children enter the work area.
3. Before and when backing, look behind and look for small children.
4. Never carry children while operating the machine. They may fall off and be seriously injured or interfere with safe operation of the machine.
5. Never allow children to play on the machine or attachment even when turned off.
6. Never allow children to operate the machine even under adult supervision.
7. Use extra care when approaching blind corners, shrubs, trees, or other obstructions that might hide children from sight.

SECURITY - continued

NOTICE

A safe operator is the best insurance against accidents. All operators, no matter how experienced they may be, should read this Operator's Manual and all other related manuals before attempting to operate an implement. Please read the following section and pay particular attention to all safety recommendations contained in this manual and those labeled on the implements and on the tractor.

DEBRIS BLOWER

Before Operation

1. Read and understand this operator's manual and tractor operator's manual. Know how to operate all controls and how to stop the unit and disengage the controls quickly.
2. Never wear loose, torn, or bulky clothing around the tractor and implement. It may catch on moving parts or controls, leading to the risk of accident.
3. Disengage clutch and shift into neutral before starting the engine.
4. Do not operate equipment in wintertime without wearing adequate winter garments.
5. Never attempt to make any adjustments while engine is running. Read this manual carefully to acquaint yourself with the equipment as well as the tractor operator's manual. Working with unfamiliar equipment can lead to accidents. Be thoroughly familiar with the controls and proper use of the equipment. Know how to stop the unit and disengage the controls quickly.
6. Keep all shields in place and properly tighten all mounting hardware.
7. Periodically, inspect all moving parts for wear and replace with authorized service parts if an excessive amount of wear is present.
8. Replace all missing, illegible, or damaged safety and warning decals. See list of decals in the operator's manual.
9. Do not modify or alter this equipment or any of its components, or any equipment function without first consulting your dealer.
10. Keep safety decals clean of dirt and grime.
11. Make sure the tractor is counterweighted as recommended by your dealer. Weights provide the necessary balance to prevent tip-over or loss of traction or steering

SECURITY - continued

Debris blower Operation

1. Before leaving the tractor/debris blower unattended, take all possible precautions. Park the tractor/debris blower on level ground, set the parking brake, disengage debris blower drive, lower the debris blower to the ground, place all levers including auxiliary control levers in neutral, shut off the engine and remove the ignition key.
2. Prior to operation, clear work area of all objects that can be picked up and thrown. Mark all curbs, pipes, etc. that cannot be moved.
3. Be sure the debris blower drive is in OFF position before starting engine.
4. Exercise extreme caution when operating on or crossing a gravel drive, walks, or roads. Stay alert for hidden hazards or traffic.
5. Do not carry passengers.
6. Keep clear of all rotating parts. Do not put hands or feet under, or into debris blower with engine running. Be especially observant of the debris blower areas of discharge, intake or all other mechanical motions.
7. Park the tractor/debris blower on level ground, set the parking brake, disengage the debris blower drive, lower the debris blower to the ground, place all control levers in neutral, shut off the engine, remove the ignition key and allow the rotating parts to stop **BEFORE** making any repairs, adjustments or inspections.
8. If the debris blower starts to vibrate abnormally, disengage the pulley, stop the engine immediately and check for cause. Excessive vibration is generally a sign of trouble.
9. Do not run the engine indoors except when starting engine and transporting attachment in or out of building. Carbon monoxide gas is colorless, odorless and deadly.
10. Do not attempt to operate on steep slopes. If operating on slopes is necessary, exercise extreme caution when changing direction.
11. Never operate debris blower without guards, and other safety protective devices in place. All tractor and debris blower shields and covers must be correctly installed at all times. When necessary to remove these, they must be reinstalled immediately.
12. Never operate debris blower near glass enclosures, automobiles, window wells, embankments, etc., without proper adjustment of the angling deflector.
13. Never operate machine at high transport speeds on a slippery surface.
14. Use extra caution when backing up.
15. Disengage power to debris blower when transporting or when not in use.
16. Never operate the debris blower without good visibility and lighting.
17. Prolonged exposure to loud noise can cause impairment or loss of hearing. Wear a suitable hearing protective device such as earmuffs or earplugs to protect against objectionable or uncomfortable noises.
18. Never allow anyone near the work area.
19. Never allow anyone to operate the debris blower until they have read the manual completely and are thoroughly familiar with basic tractor and debris blower operation.
20. Always make sure all debris blower components are properly installed and securely fastened **BEFORE** operation.
21. Keep away from discharge. This debris blower has the capacity to throw debris at far distances.
22. Never direct discharge towards people or animals. Thrown debris can cause serious injury.

SECURITY - continued

THE TRACTOR

General Information

1. Read the operator's manual carefully before using tractor. Lack of operating knowledge can lead to accidents.
2. Do not allow anyone but the operator to ride on the tractor. There is no safe place for extra riders

Operating the Tractor

1. Never run the tractor engine in a closed building without adequate ventilation, as the exhaust fumes are very dangerous.
2. Never allow an open flame near the fuel tank or battery.
3. Make sure the shield is installed when using a PTO-driven equipment and always replace the shield if damaged.
4. Always bring the tractor to a complete stop, shut off the engine, lower the implement to the ground and remove the ignition key before leaving the tractor.
5. Never park the tractor on a steep slope.
6. Do not attempt to operate on steep slopes.
7. Use of tire chains for better traction and stability is recommended.
8. Always drive the tractor at speeds compatible with safety, especially when operating over rough ground, crossing ditches, or when turning.
9. Handle fuel with care, as it is highly flammable.
10. Use approved fuel container.
11. Never add fuel to a running engine or a hot engine.
12. Fill fuel tank outdoors with extreme care. Never fill fuel tank indoors. Replace fuel cap securely and wipe up spilled fuel.
13. Never allow anyone to operate the debris blower until they are thoroughly familiar with basic tractor and debris blower operation.
14. A minimum 20% of tractor and equipment weight must be on the tractor front wheels when attachments are in transport position. Without this weight, tractor could tip over, causing personal injury or death. The weight may be attained with a loader, front wheel weights, ballast in tires or front tractor weights. Weigh the tractor and equipment. Do not estimate.
15. Always make sure all debris blower components are properly installed and securely fastened BEFORE operation.

During Operation

1. Do not allow anyone to ride on the tractor/debris blower at any time. There is no safe place for passengers on this equipment. The operator MUST sit in the tractor seat.
2. Eye and hearing protection is recommended when operating the debris blower.
3. Operate only during daylight hours, or when the area is well lit with bright artificial light.
4. Disengage the PTO (turn to "OFF"), place the transmission in neutral, set the parking brake, shut off the engine and remove the key, and make sure rotating components have stopped BEFORE leaving the operator's seat.
5. Inspect the debris blower after striking any foreign object to assure that all debris blower parts are safe and secure and not damaged.

SECURITY - continued

MAINTENANCE

1. Park the tractor/ debris blower on level ground, set the parking brake, disengage the PTO, shut off the engine, remove the key, and lower the implement to the ground BEFORE making any debris blower adjustments.
2. To avoid injury, do not adjust or service the debris blower with the tractor engine running. Making sure rotating components have completely stopped before leaving the operator's seat
3. Always wear eye protection when cleaning or servicing the debris blower.
4. Do not work under any part of the tractor or debris blower, unless it is securely supported by safety stands.
5. Make sure all shields and guards are securely in place following all service, cleaning, or repair work.
6. Do not modify or alter this equipment or any of its components or operating functions. If you have questions concerning modifications, consult with your dealer.

TRANSPORTATION

1. If the tractor/ debris blower is to be driven on public roads, it must be equipped with an SMV (Slow Moving Vehicle) sign. Check local traffic codes that may apply to unit usage on public roads and highways in your area.
2. Be alert for all other traffic when driving the tractor/ debris blower on public roads or highways.
3. Reference the Roadway Transport section on page 19.

STORAGE

1. Before storing the debris blower, certain precautions should be taken to protect it from deterioration.
2. Clean the debris blower thoroughly.
3. Make all the necessary repairs.
4. Replace all Safety Signs that are damaged, lost, or otherwise become illegible. If a part to be replaced has a sign on it, obtain a new safety sign from your dealer and install it in the same place as on the removed part.
5. Repaint all parts from which paint has worn or peeled.
6. Lubricate the debris blower as instructed under "**Lubrication**" section.
7. When the debris blower is dry, oil all moving parts. Apply oil liberally to all surfaces to protect against rust.
8. Attach driveline shield safety chain around driveline by passing it over the upper hitch
9. Store in a dry place.

DECALS

Replace immediately if damaged

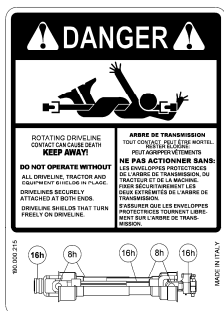

5RD2500813

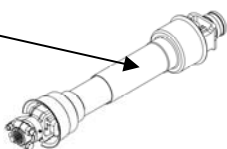

CAUTION

To Avoid Serious Injury:

- Read operator's manual before operating, servicing or repairing equipment. Follow all safety rules and instructions. (manuals are available from your selling dealer.)
- Never allow riders.
- Keep bystanders away from equipment during operation.
- Operate from tractor seat only.
- Keep all shields in place and in good condition.
- Lower equipment to ground, stop engine, remove key and set brake before dismounting tractor.
- Never allow children or untrained persons to operate equipment.

5RD2500785

ATTENTION

Pour Éviter Des Blessures Sérieuses:

- Lire le Manuel de l'Opérateur avant de manoeuvrer, d'effectuer l'entretien ou de réparer l'équipement. Suivre toutes les consignes de sécurité. Les manuels sont disponibles chez votre concessionnaire.
- Ne jamais laisser des passagers monter sur l'équipement.
- Garder les spectateurs loin de l'équipement pendant les opérations.
- Toujours manoeuvrer l'équipement à partir du siège du tracteur.
- Maintenir les gardes en place en tout temps et en bonne condition.
- Abaisser l'équipement au sol, couper le contact, retirer la clé et appliquer le frein avant de quitter le tracteur.
- Ne jamais laisser un enfant ou une personne non formée manoeuvrer l'équipement.

5RD2500786

DANGER

Rotating Driveline Contact Can Cause Death. Keep People And Clothing Away. Do not operate without:

- All driveline, tractor and equipment shields in place.
- Driveline securely attached at both ends.
- Driveline shield turning freely on driveline.

Transmission Rotative A Cardan. Tout Contact Peut Causer La Mort. Tenir Les Vêtements Et Personnes À L'écart

No pas opérer sans:

- Que tous les protecteurs du tracteur, de l'équipement et de l'arbre à cardan soient en place.
- L'arbre à cardan fixé solidement à chaque bout.
- Que les protecteurs tournent librement sur l'arbre à cardan.

5RD2500792

CAUTION

Operate only with 540 rpm PTO

ATTENTION

Toujours opérer avec une P.D.F. de 540 tr/min

5RD2500793

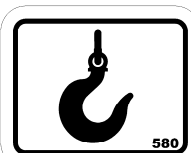

5RD2500624



5RD664391

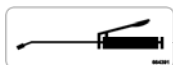

5RD664391



5RD664391



5RD2500616



5RD2500820

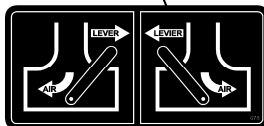

5RD2500830



DANGER

Do not stand near the blower when in operation due to high velocity discharge of debris.

Ne pas se tenir à proximité de la souffluse à débris lorsque celle-ci fonctionne. Il y a possibilité de projection d'objets à haute vitesse.

5RD2500827



DANGER

To avoid serious injury: keep hands out of this blower outlet while running.

Pour éviter des blessures graves: garder les mains éloignées de cette sortie lorsque le moteur est en marche.

5RD2500828

ASSEMBLY

TRACTOR PREPARATION

See Dealer for Tractor Preparation information.

DEBRIS BLOWER ASSEMBLY

Use the present manual and lay out all parts for assembly. Separate bolts and nuts into various sizes. After assembly, torque all the bolts according to the **Torque Specification Table** at the end of the manual.

Debris Blower removing front wooden crate (Fig. 1)

1. Remove the six 3/8"NC x 3/4" carriage bolt and six 3/8"NC serrated flange nut to remove the belt protector (item 1).
2. Keep the hardware for further use. Remove the four screws (item 4) and 1/4" flat washers (item 5) that maintain the Debris Blower to the crate.
3. Reinstall the belt protector (item 1) with the six 3/8"NC x 3/4" carriage bolt and six 3/8"NC serrated flange nut removed previously.
4. Remove the three round wire lock pins (item 6) from the wheel support pins and attach them in the holes provided on the side of the Debris Blower (item A).
5. You may use the two lifting holes (item 7) to move the Debris Blower more easily.

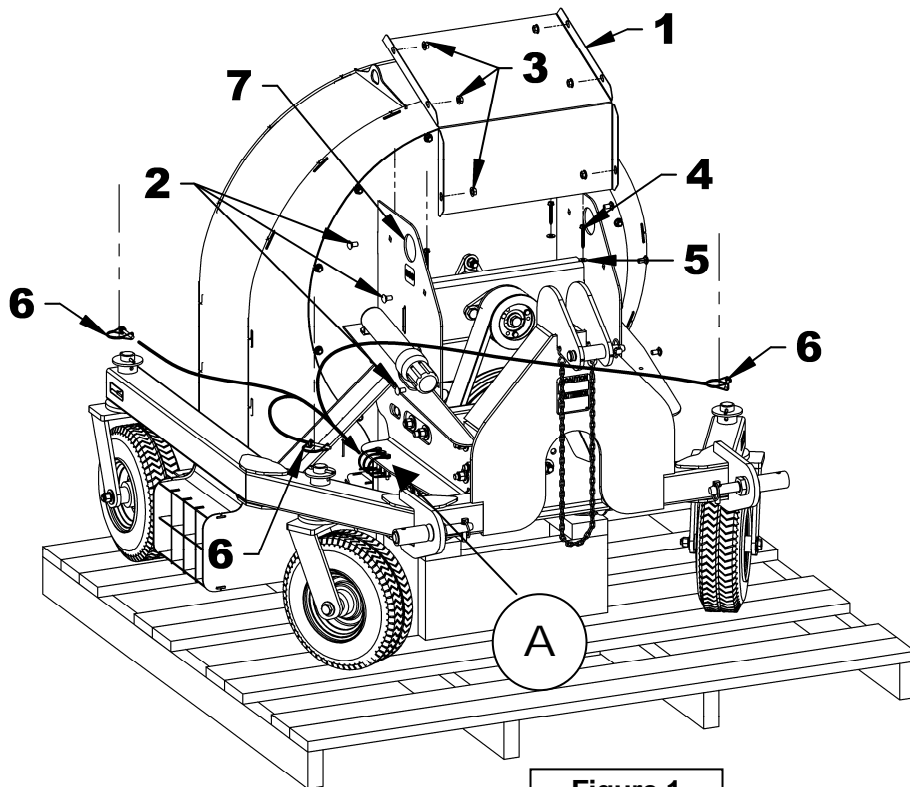

Figure 1

ASSEMBLY

Debris Blower Installation on a Three Point Hitch (Figures 2-3)

NOTE: To install on a Cat. 1 three point hitch, the hitch pins (item 3) must be oriented toward the inside. On a Cat. 2, they must be oriented toward the outside.

NOTE: To install on a quick hitch, remove the 1 1/4" OD bushing from the 3/4" upper pin. If you install the debris blower on a Cat.2 tractor, you must remove the two 1 1/2"OD bushings attached to the hitch pins with spring pins (items 1-2-3).

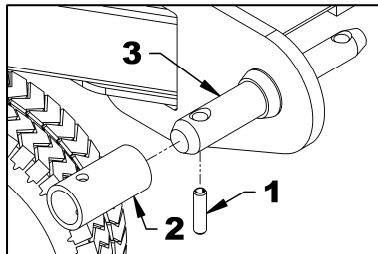

1. Attach the upper and lower arms to the tractor:

CATEGORY 1 (Figure 2)

- A- Attach the tractor lower arms (item 1) to debris blower pins (item 2) from the inside and secure with linchpins (item 3).
- B- Secure the tractor upper arm (item 4) between the upper hitch plates (item 6) with a pin (item 5) and a linchpin (item 3).

CATEGORY 2 (Figure 3)

- A- Attach the tractor lower arms (item 1) to debris blower pins (item 2) from the outside and secure with linchpins (item 3).
- B- Secure the tractor upper arm (item 4) between the upper hitch plates (item 6) with a pin (item 5) and a 1"OD x 2" lg bushing (5RD4600056) (item 7 – not included) and a linchpin (item 3).

2. Lower the debris blower to the ground to adjust the level, parallel to the ground, with the tractor upper arm.
3. Adjust the tractor anti-sway arms (item 8) to prevent back and forth movement of the debris blower. Make sure there is no contact with the tractor tires.

⚠ ATTENTION

Before connecting debris blower driveline to tractor drive shaft, make sure driveline is not too long in raised, lowered and middle position. If the driveline is too long it must be shortened, to avoid damaged to tractor. See procedure on pages 14 to 16.

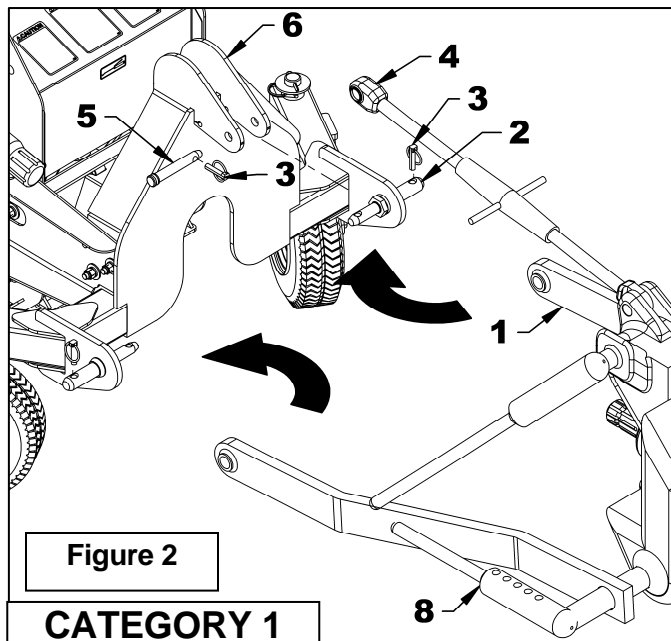

Figure 2

CATEGORY 1

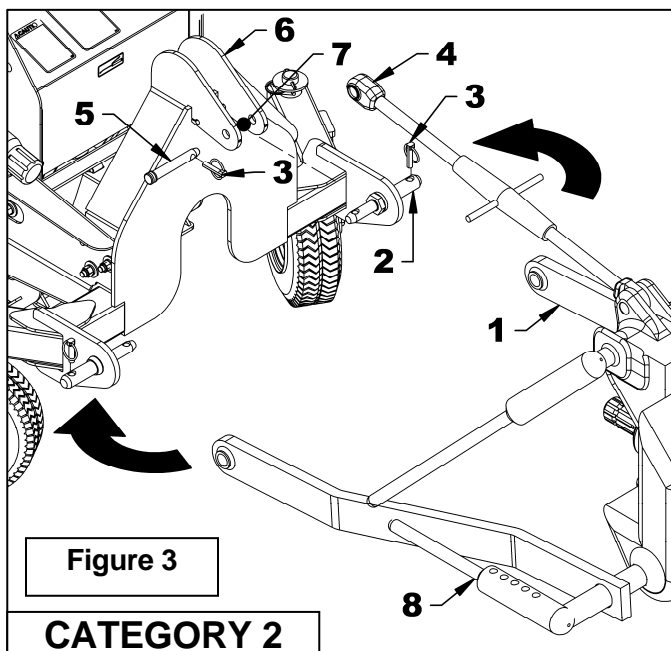

Figure 3

CATEGORY 2

ASSEMBLY

Installation of the Debris Blower with a Quick Hitch Cat. 1

Figure 4: Place the Debris Blower (item 1) on flat hard ground. Unlock the lower locks of the quick hitch (item 2) by lifting the two hitch levers. Back up the tractor slowly aligning the three quick hitch hooks (item 4) with the three bushings (item 3) of the debris blower and lock the quick hitch lower locks.

IMPORTANT: To install on a Cat. 1 three point hitch with a Quick Hitch, the pins with 1 1/2"OD bushings must be oriented toward the inside. On a Cat. 2 quick hitch, they must be oriented toward the outside.

Installation of the Debris Blower with a Quick Hitch Cat. 2

- Figure 5a:** Remove the linchpins (item 1), lockwashers (item 3), nuts (item 2) and pins (item 4). Use a round wood stalk to block the cat.1 and 2 pin during the loosening and the tightening of the nut.
- Figure 5b:** Install the pins (item 1) in the position illustrated and reinstall the lockwashers (item 3), nuts (item 2), and linchpins (item 4).
- Figure 5c:** Place the debris blower (item 1) on flat hard ground. Unlock the lower locks of the quick hitch (item 2) by lifting the two hitch levers. Back up the tractor slowly aligning the three quick hitch hooks (item 4) with the three bushings (item 3) of the debris blower and lock the quick hitch lower locks.

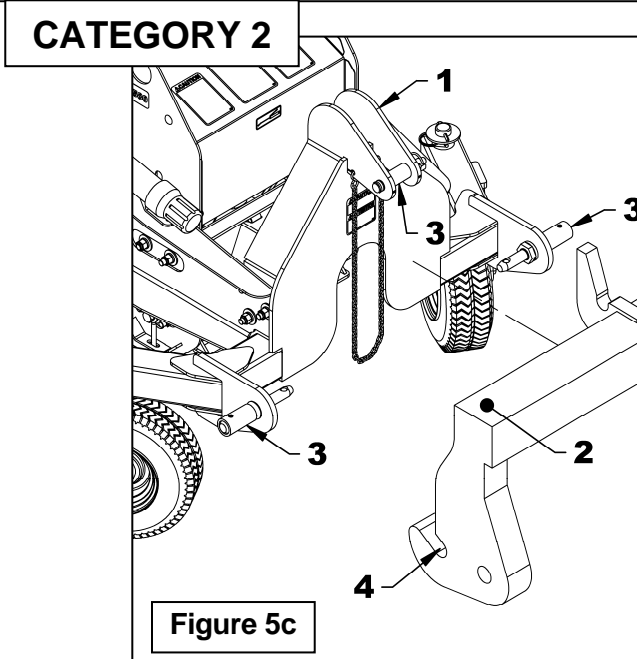
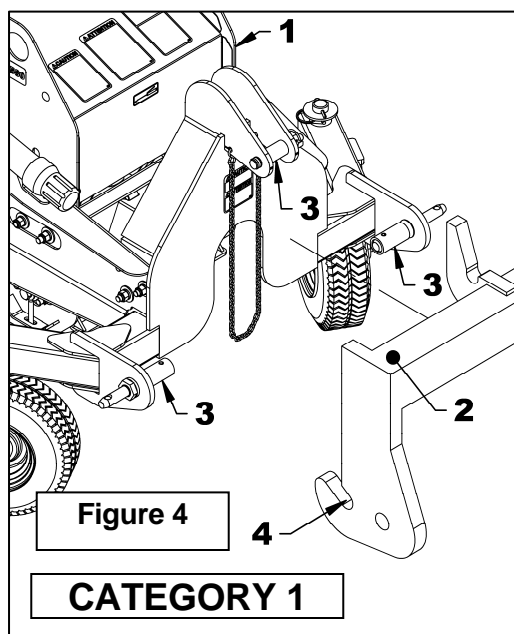
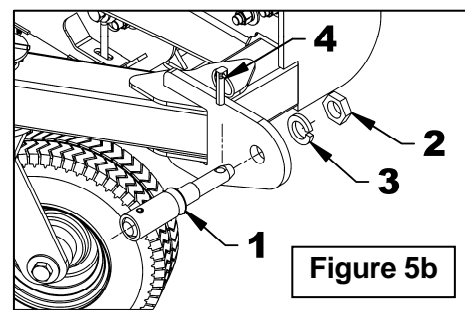
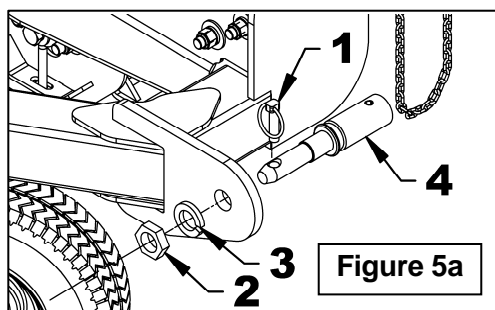

ASSEMBLY

Driveline Preparation

IMPORTANT:

A proper initial installation will give you years of satisfactory service on your equipment. Please read carefully following instructions that have been specially included to help you and ensure you are satisfied with your purchase.

Danger: Tractors Too Big

It is dangerous to use a tractor that is too big and powerful. The tractor will always be able to overload the blower, even if the machine is already at maximum capacity. Furthermore, tractors being very high, the driveline angles will be excessive which means the universal joints will be very vulnerable and the life of the driveline will be dramatically reduced.

HOW TO DETERMINE DRIVELINE ANGLES

IMPORTANT: To obtain the proper universal joint angles, it is recommended to adjust the three point hitch at the furthest point from the tractor recommended by the manufacturer

The universal joint angle is directly related with the life of driveline. In order to reduce the angle, it is necessary to increase the distance between the debris blower and the tractor.

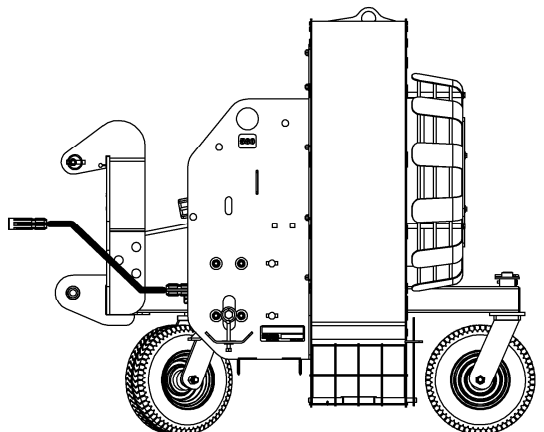

Angles of Driveline Joints Too Large
Avoid

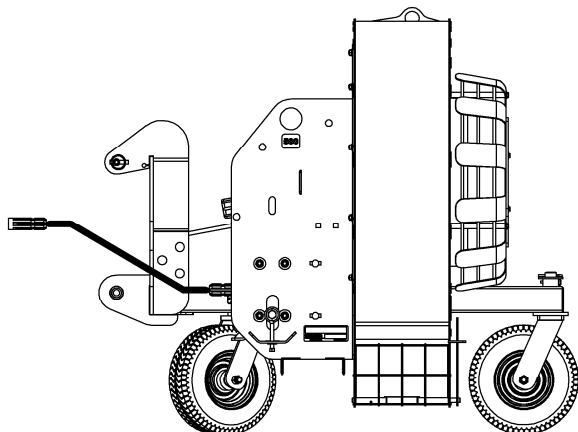

Reasonable Angles of Driveline Joints
Acceptable

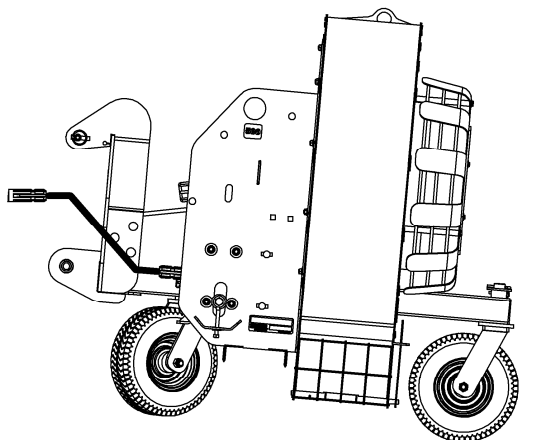

Unequal Angles at Driveline Joints
Avoid

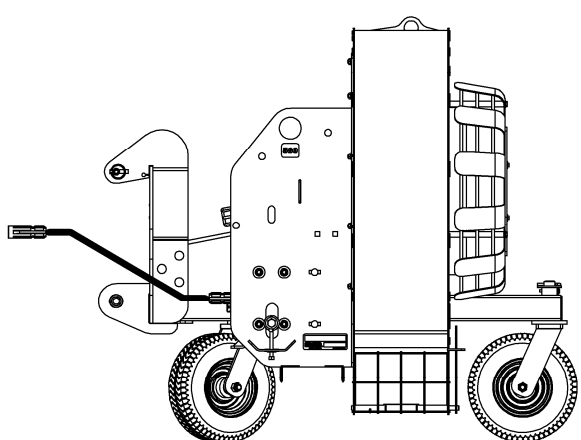

Equal Angles at Driveline Joints
Recommended

ASSEMBLY

ANGLES AT EACH END OF DRIVELINE

To avoid damages to the driveline or the debris blower, it is recommended to always keep tractor driveline and debris blower input shaft parallel.

DETERMINING DRIVELINE LENGTH

IMPORTANT: Before using the equipment, make sure the driveline is not too long. At working position, the two half drivelines must intersect each other sufficiently to insure maximum efficiency but there must not be any interference.

1. To determine the "L" length for your tractor model first find the "X" factor by measuring the horizontal distance between the end of the tractor's drive shaft and the end of the debris blower's driven shaft when the debris blower is in transport position as shown on **Figure A**.

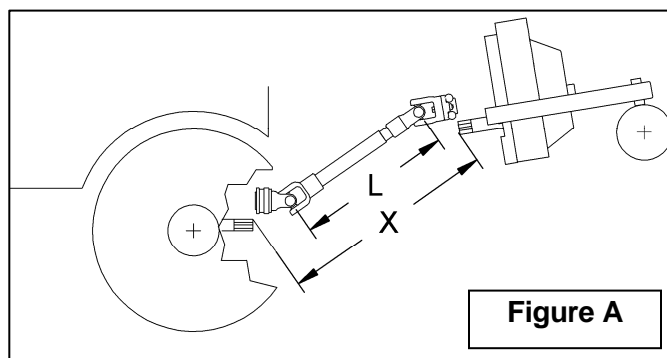

2. Choose in the table below the "Y" factor according to the tractor category and deduct that number from "X" to determine "L" which is the center-to-center length between the universal joints.

L = X - Y	
3 PTS HITCH CATEGORY	Y
Cat. 1	4 1/2"
Cat. 2	5 1/2"

ASSEMBLY

NOTE: Before cutting, make sure the two shafts intersect by at least 7 3/4" when in working position that is when the debris blower rests on the ground.

3. Hold the two half-shaft side by side and locate the "L" length between the two center-to-center half-shaft universal joints. Mark off the zone to be cut on both halves opposite each half-shaft guard as shown on **Figure B**.
4. Cut off inner and outer guard tubes as well as the inner and outer telescopic sections.

5. Cut the guard a second time leaving the same distance between the end of the guard and the end of the shaft as existed before. To obtain the proper distance "A" shown on Figure C, cut the guard according to the following table:

DISTANCE A	
Male PTO	Female PTO
1 3/4"	1 1/4"

6. File down tubes and remove chips.
7. Apply grease to inside of outer telescopic section.

IMPORTANT: Work with fully guarded shafts only!

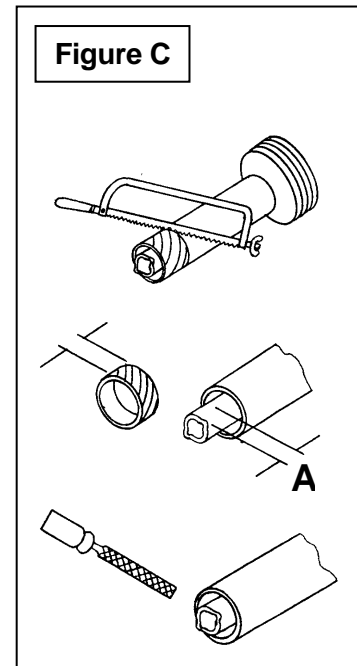
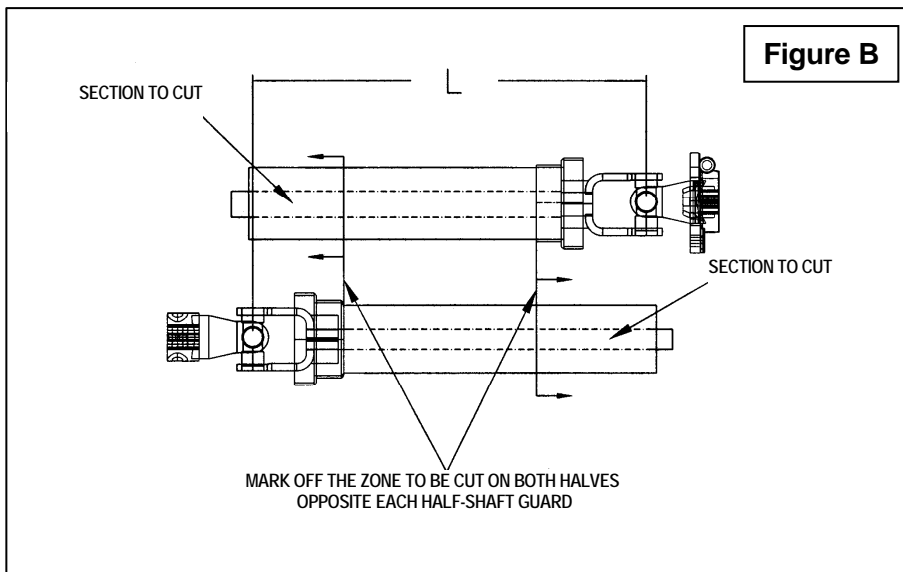

ASSEMBLY

Driveline Installation

(Figure 6)

1. Separate the debris blower from the three point or quick hitch.
2. Grease driveline sliding surfaces and yoke (item 1).
3. Remove the bolts (items 2) from the driveline yoke (item 1) and connector to the debris blower shaft. Make sure the driveline is well secured to the shaft by reinstalling the bolts and nuts (item 2-3) in the order shown. Tighten the bolts according to the **Torque Specification Table** at the end of the manual.
4. Attach safety chain (item 4) around the upper link to prevent the guard from spinning.

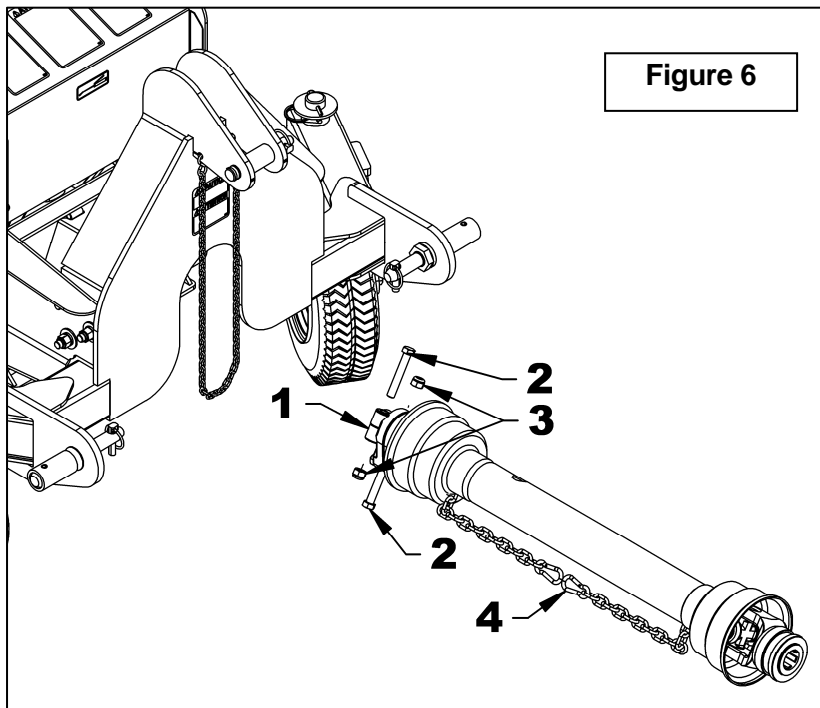

ASSEMBLY

Removing Debris Blower from Tractor (Figure 7)

1. Set parking brake and turn engine off.
2. Direct the wheel supports (item 2) along the housing support tube (as illustrated) and lock in position with three round wire lock pins (item 1), that are attached to the debris blower housing (item A).
3. **3 point Hitch only:** Detach upper arm by removing linchpin and pin.
4. Disconnect driveline (item 3) from tractor and attach the driveline safety chain (item 4) to the housing support with the chain spring hook.
5. **3 point Hitch only:** Carefully detach lower arms from hitch pins by removing linchpins and loosen anti-sway turnbuckles.
6. **Quick Hitch only:** Lift the two levers to release lower hooks.
7. Lower the tractor 3 point system and slowly back tractor away from the Debris Blower.

IMPORTANT: To avoid damages to the debris blower, retorque all bolts after the first 10 hours of operation.

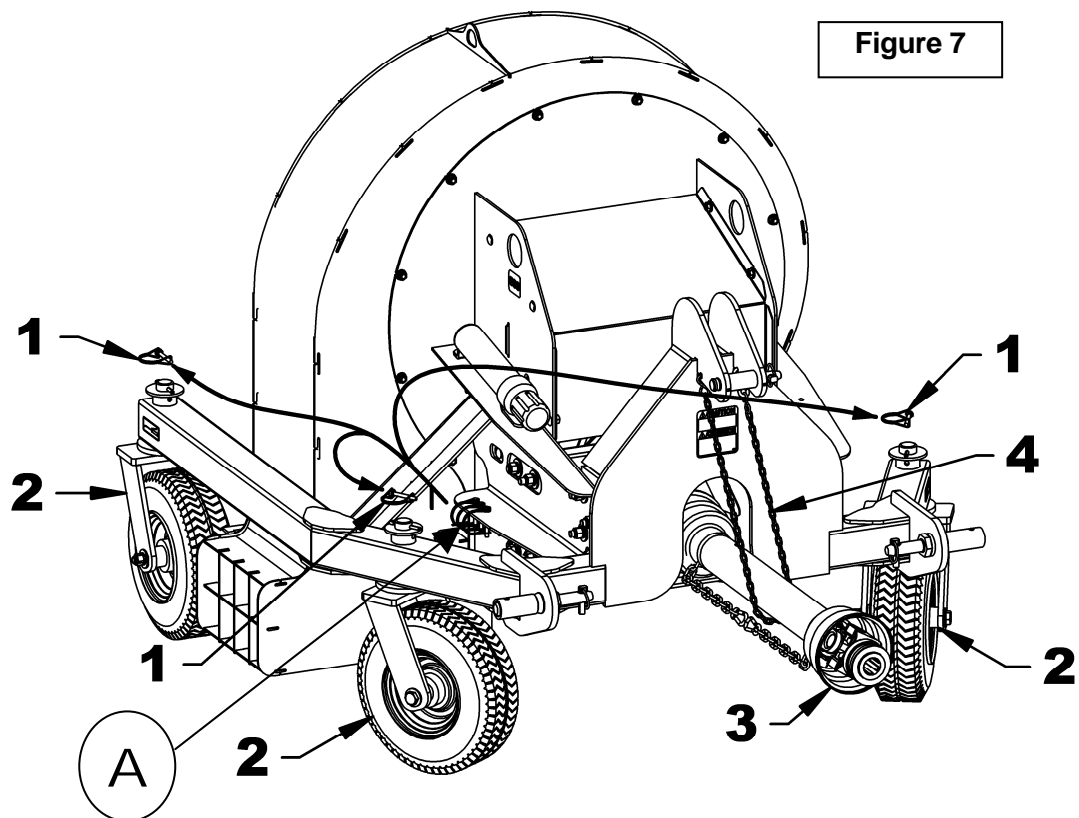

Figure 7

OPERATION

GENERAL PREPARATION

1. Read the operator's manual carefully before using the tractor and debris blower. Be thoroughly familiar with the controls and proper use of the equipment. Know how to stop the unit and disengage the controls quickly.
2. Make sure the impeller operates freely.
3. Check the shear bolt on the PTO, for proper tightness.
4. Wear adequate winter outer garments while operating equipment.

ATTENTION

To avoid personal injury, be sure the tractor engine is off, the drive shaft disengaged, and all movement has stopped before making any adjustments.

Roadway Transport (Figures 8a-8b-8c)

1. Position the tractor and the debris blower on a level surface.
2. Adjust the 3 point height to maximum.
3. **Figure 8a:** Go to the front of the debris blower at approximate distance of 15 feet from it, in the middle and at the same level than the tractor.
4. **Figure 8b:** Look toward the tractor and check if the rear tractor lights are all visible, specially the lower ones. (item 1). If some are hidden, lower the 3 point until the lights become visible.
5. **Figure 8c:** When the height is set, take note of the adjustment on the lever graduation (item 1) for futures utilization with the same tractor. Then adjust the lock (item 2) to the position found previously to make sure to not exceed the prescribed height for security.
6. If you use another equipment and modify the lock position, make sure to reset the lock to the good position to make the tractor lower rear lights always visible.

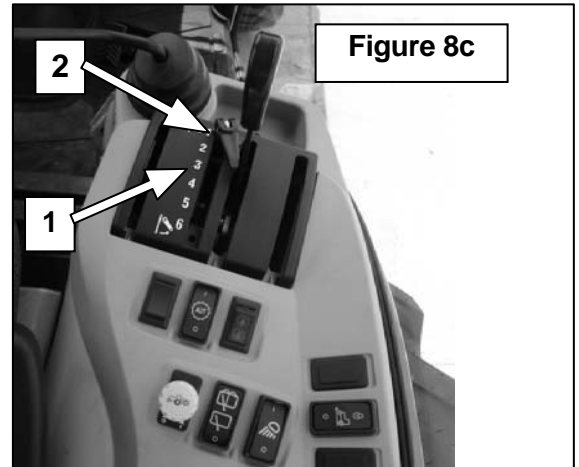
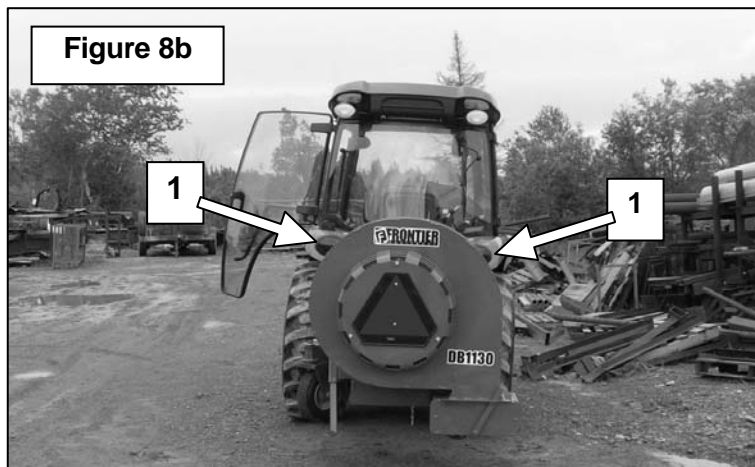
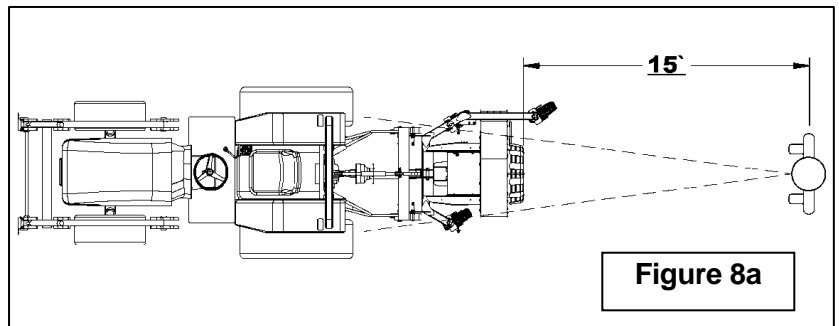

OPERATION

OPERATING CONTROLS

Debris Blower Commands

1. Use the PTO button to start and stop the impeller. Start the engine and put the throttle lever at low engine speed. Engage the PTO lever and maintain engaged. Make sure the debris blower is turning in the right direction. If not, switch the quick couplers. To stop the rotation, disengage the PTO button.
2. Raise and lower the debris blower using the hydraulic lift lever located on the tractor. Pulling the lever backward raises the debris blower, pushing the lever forward lowers the debris blower.
3. Control brush speed with the RPM that controls the debris ejection power.

Debris Blower Utilisation

1. A debris blower purpose s to displace rather light debris to a variable distance according to the impeller speed. For heavy debris, it is recommended using some other equipment type such as a rotary broom. For an optimum performance, lower the debris blower as the 3 wheels touch the ground. Make sure the loader control lever is in floating position to allow the equipment to follow the ground variation and so more debris to be blown.
2. For light debris, use a higher vehicle ground speed. For heavier debris, use a reduced vehicle ground speed. For small area, lower the tractor motor speed to eject debris on a short distance. For wider area, use higher speed.

Nozzle air ejection Orientation

Equipment air ejection can be done to the right or the left. To change direction, move the orientation arms on the debris blower. See decal on equipment to check arm positions for right orientation.

 **WARNING:** To avoid serious injuries: never move the orientation arm when the debris blower is running.

OPERATION

ADJUSTMENTS

Belt Tension Adjustment (Figure 9)

1. Remove the belt protector (item 5) by removing the six 3/8"NC x 3/4" carriage bolts and six serrated flange nuts (items 6-7).
2. Loosen the eight 1/2"NC nylon insert locknut (item 1).
3. Tighten eyebolt nuts (item 2). With a belt tension gauge check for a 35lbs tension and a 3/16" displacement in the center in all belt axis (item 3).
4. Realign the driving pulley assembly (item 4) by pressing the support against the bolted guides. Tighten loosely the eight 1/2"NC nylon insert locknuts (item 2) loosen previously. With a long ruler that may cover the distance between pulleys, check the pulleys alignment. If alignment is good, tighten the eight 1/2"NC nylon insert locknuts (item 2). If not, follow next step.
5. If the belts are not well aligned, loosen the guide nuts and the eyebolt nuts. Align the two pulleys, slightly tighten the eight 1/2"NC nylon insert locknuts (item 2). Press the guides against the driving pulley assembly (item 4) and tighten guide nuts. Redo step 2. Check the pulleys alignment and if the driving pulley assembly is well pressed on guides. If so, tighten firmly the eight 1/2"NC nylon insert locknuts. If not, repeat procedure.
6. Reinstall the belt protector (item 5) with the six 3/8"NC x 3/4" carriage bolts and six serrated flange nuts (items 6-7).

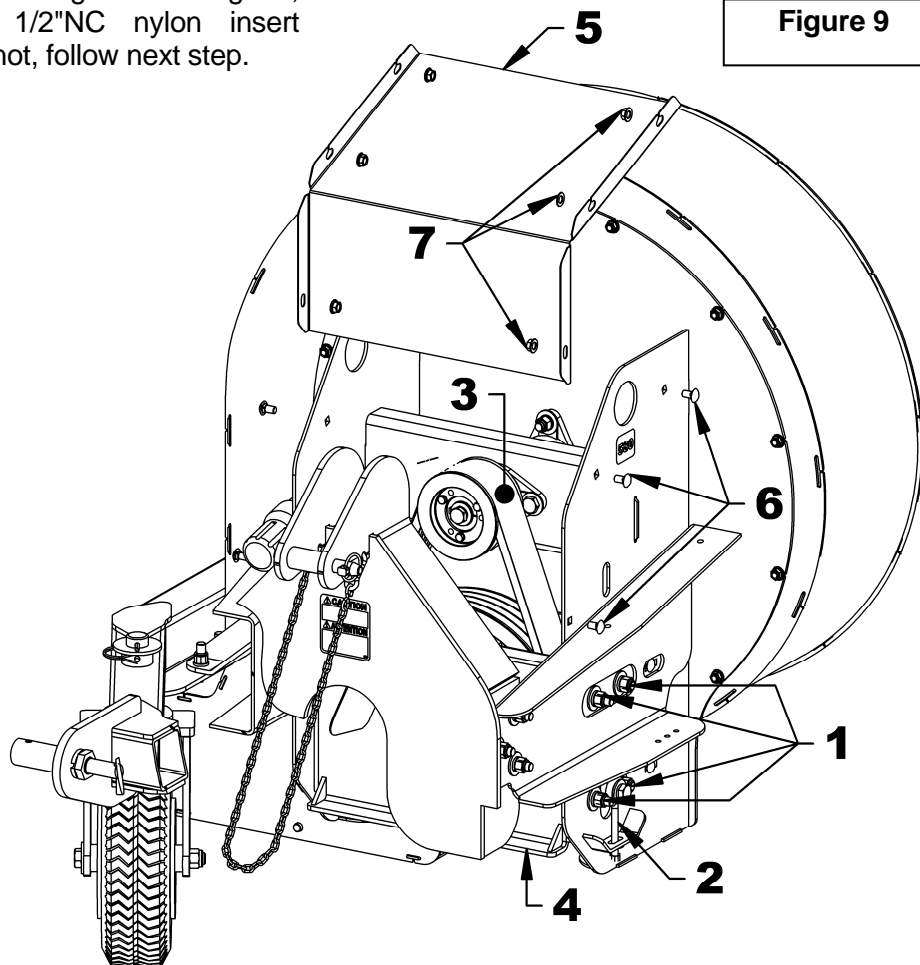

Figure 9

MAINTENANCE

MAINTENANCE

Shearbolt

Check the shearbolt indicated on the figure below at frequent intervals for proper tightness to be sure the debris blower is in safe working condition. If the shearbolt needs replacement, use the following part only

Driveline

Shearbolt M8 x 1.25 x 50mm gr. 6.6 with nut. Part # 5RD4700060.

 **WARNING**

Provide adequate blocking before working under the debris blower when in the raised position.

Driveline

IMPORTANT: When the debris blower is not used for more than two weeks, perform driveline maintenance and always store it in a dry place, away from bad weather conditions.

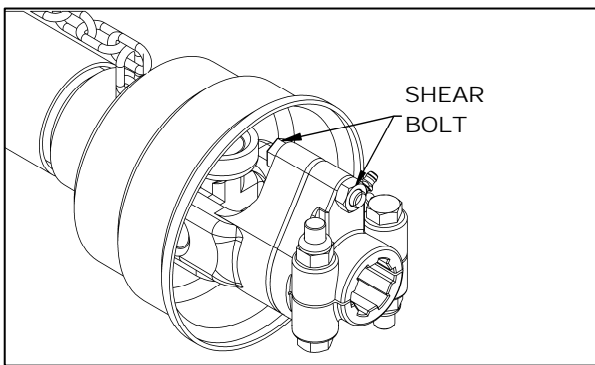

MAINTENANCE

LUBRICATION

Use oil or a grease gun and lubricate as follows:

DESCRIPTION	INTERVAL	LUBRICATION REQUIRED
Driveline	8 hours	Grease each universal joint. Separate the sliding parts and cover each one of them with grease
	16 hours	Oil the push pins
Bearing	24 hours of operation	Grease each bearing of the impeller shaft, the driving shaft, the wheel support pins and the wheels.

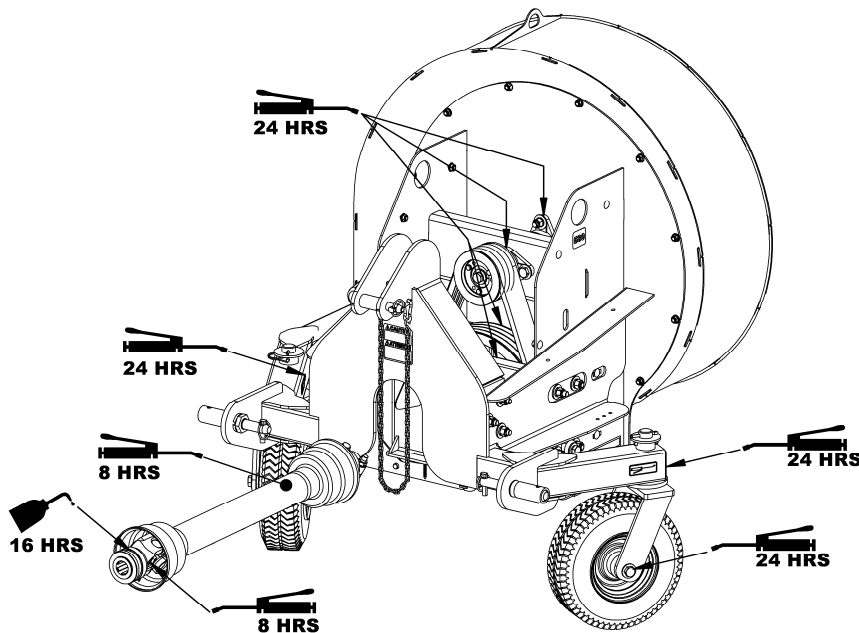

PERIODIC CHECKS

DESCRIPTION	TIME INTERVAL	REQUIRED CHECKS
Belt	Each lubrication	Check for damages
Housing, hitches, impeller wheel supports	100 hours of use	Repair if needed
Hardware	24 hours of use	Check and tighten if needed
Tires	Each utilization	Check pressure

MAINTENANCE

Belt Replacement (figures 10a-10b-10c)

1. **Figure 10a:** Remove the belt guard (item 1) and the six 3/8"NC x 3/4" carriage bolts (item 2) and six 3/8"NC serrated flange nuts (item 3).
2. **Figure 10a:** Remove the 1/2"NC x 2 1/2" bolt hex (item 4) and the 1/2" lockwasher (item 5), the 1/2" flat washer (item 6), the spacer (item 7) and the 1/2" nylon insert locknut (item 8).
3. **Figure 10a:** Remove the 3/8" x 5" eyebolt (item 9), the flat washer (item 10) and the nylon insert locknut (item 11).
4. **Figure 10a:** Perform the 2 and 3 steps for the second eyebolt.
5. **Figure 10a:** Remove the eight 1/2"NC nylon insert locknuts (item 12), the eight 1/2" lockwashers (item 13), the eight 1/2" (9/16" int.) flat washers (item 14) and the eight 1/2"NC x 1 3/4" carriage bolts (item 15).
6. **Figure 10b:** With a hoist, raise the drive pulley assembly (item 2) with a two hook chain (item 1) to well balance the weight. (This assembly weights approximately 75 pounds).
7. Put the drive pulley assembly to the ground and move forward the debris blower.
8. **Figure 10c:** Remove the two set screws of the bearing (item 1).
9. **Figure 10c:** Clean up the shaft behind the bearing to remove the rear support plate more easily (item 2).
10. **Figure 10c:** Place the new belt (item 3) over the drive pulley (item 4).
11. **Figure 10c:** Reinstall the rear support plate (item 2) and the two set screws on the bearing (item 1) without tightening.
12. **Figure 10c:** Align the four notches with the ones on the drive pulley assembly (item 4).
13. Place the drive pulley assembly to the ground and back up the debris blower over it.
14. Raise the drive pulley assembly with the hoist and reinstall the eight 1/2"NC x 1 3/4" carriage bolts with the flat washers, lockwashers and nylon insert locknuts. Do not tighten.
15. Reinstall the two 3/8" x 5" eyebolts with the 1/2"NC x 2 1/2" hex bolts, the 1/2" lockwashers, the 1/2" flat washers, the spacers and the 1/2" nylon insert locknuts.
16. Go to «BELT TENSION ADJUSTMENT » section.

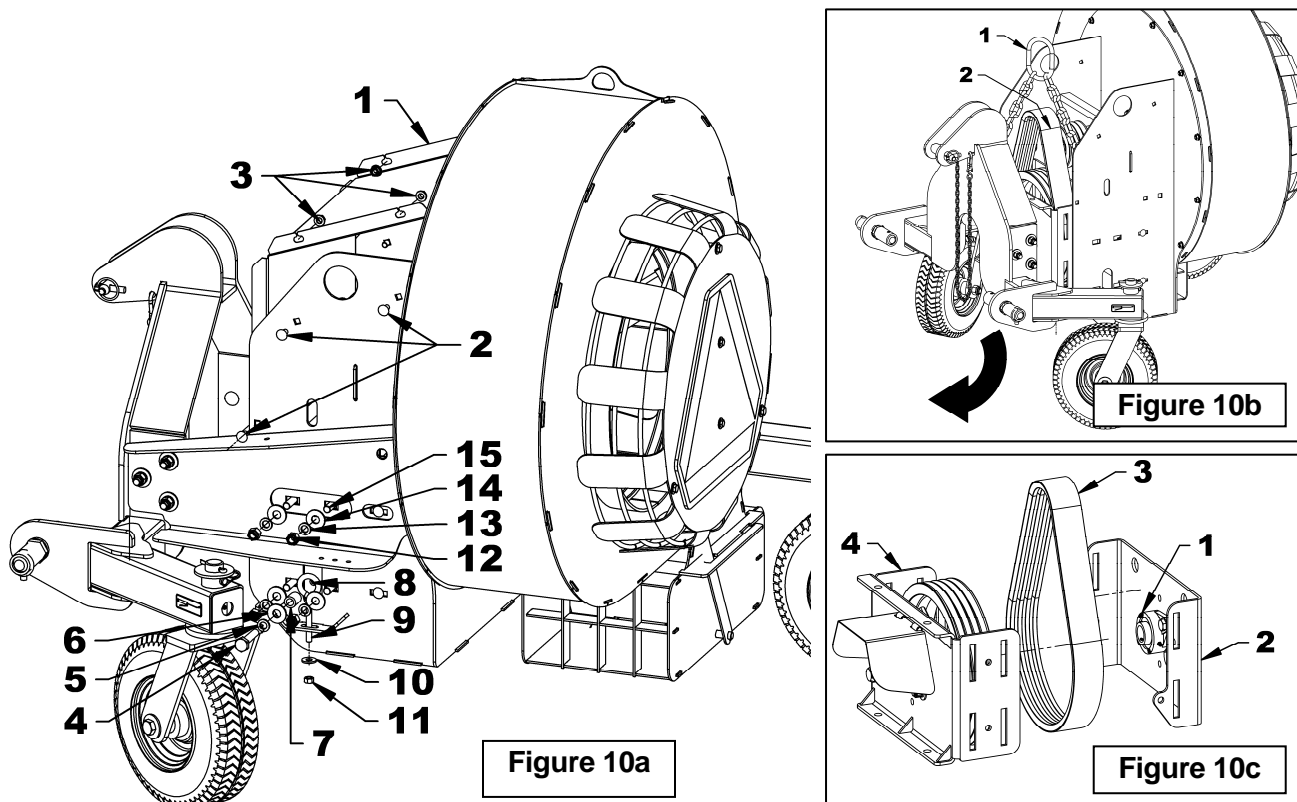

MAINTENANCE

Impeller Removing and Reinstallation (figures 11a-11b)

TO REMOVE THE IMPELLER:

1. **Figure 11a:** If the debris blower is in storage, remove the round wire lockpin (item 1). Then remove the 1/4" cotter pin (item 2), the flat washer (item 3) and the wheel assembly (item 4). Place the arm on a small wood block as a temporary support.
2. **Figure 11a:** Attach the housing (item 7) to a hoist with the hook provided on the housing (item 5). Remove the twelve 3/8" NC serrated flange nuts (item 6) and move the housing to the front to take it out from the impeller.
3. **Figure 11b:** Remove the 1/2"NC x 1" hex bolt, the lockwasher and the flat washer (items 2, 3 and 4) in front of the impeller (item 1).
4. **Figure 11b:** Then remove the 1/2"NC x 3 1/2" hex bolt (item 5) and the 1/2"NC nylon insert locknut (item 6).
5. **Figure 11b:** The impeller is provided with an ejection device, so just screw a 3/4"NC x +/- 2 1/2" hex bolt (item 7) that pushes against the shaft end and ejects the impeller (item 1).

TO REINSTALL THE IMPELLER:

1. **Figure 11b:** Remove the 3/4" x +/- 2 1/2" hex bolt (item 7).
2. **Figure 11b:** Apply grease on the shaft to facilitate the reinstallation. Make sure to align the hole in the impeller with the hole on the shaft, where the 1/2"NC x 3 1/2" hex bolt was installed (item 5). A light punch on the impeller should be enough to insert it on the shaft.
3. **Figure 11b:** Attach with the 1/2"NC x 1" hex bolt, the lockwasher and the flat washer (items 2, 3 and 4) in front of the impeller.
4. **Figure 11b:** Then attach the impeller with the 1/2"NC x 3 1/2" hex bolt (item 5) and the 1/2"NC nylon insert locknut (item 6).
5. **Figure 11a:** Reinstall the front housing and the wheels (follow the preceding procedure in reverse).

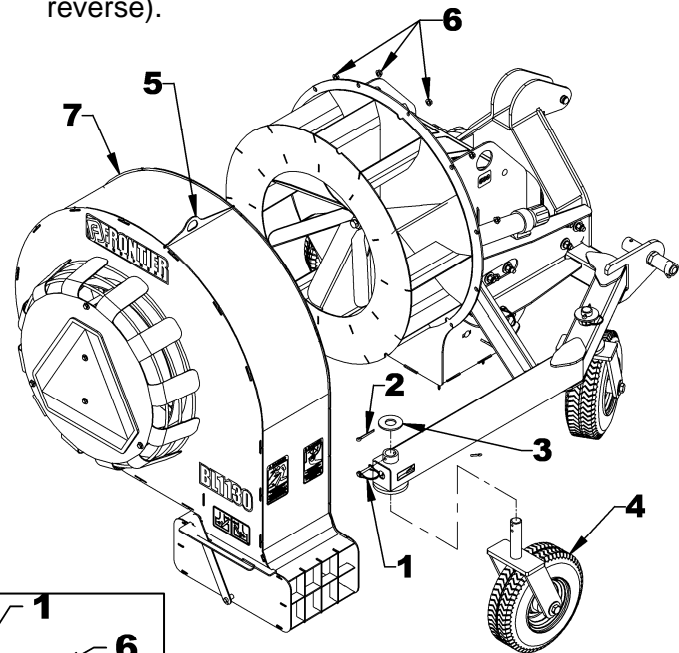

Figure 11a

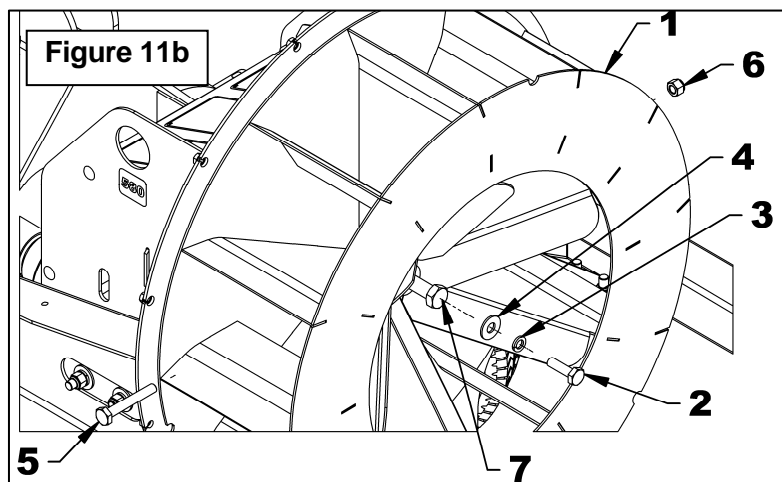
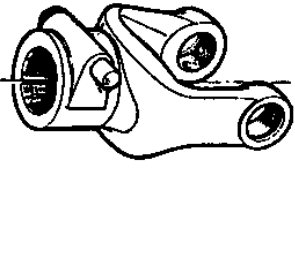



Figure 11b

MAINTENANCE

DRIVELINE TROUBLESHOOTING

	AVOIDABLE DAMAGES	POSSIBLE CAUSES	CORRECTIVE ACTIONS
<p><u>QUICK-DISCONNECT YOKE</u></p> 	<ul style="list-style-type: none"> Quick-disconnect pin tight or completely seized. Quick-disconnect pin damaged (broken or bent) Quick-disconnect pin damaged in the locking portion. 	<ul style="list-style-type: none"> Quick-disconnect pin dirty (insufficient maintenance). Quick-disconnect pin defective (forced engagement, incorrect handling) Excessive shaft length. Axial loads too high. 	<ul style="list-style-type: none"> Clean, oil and follow service instructions. Replace quick-disconnect pin. Shorten shaft length (cut both telescopic tubes as well as shield and remove burrs). Replace quick-disconnect pin. Clean and grease telescopic tubes, and replace both tubes, if necessary. Replace quick-disconnect pin.



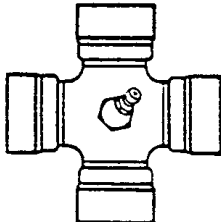
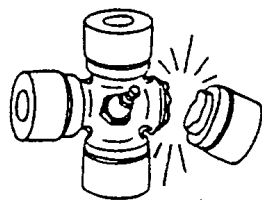
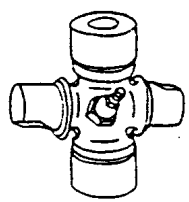

Note: Quick-disconnect pins must be cleaned and greased every 16 hours.

	AVOIDABLE DAMAGES	POSSIBLE CAUSES	CORRECTIVE ACTIONS
<p><u>YOKE</u></p> 	<ul style="list-style-type: none"> Yoke ears deformation 	<ul style="list-style-type: none"> Excessive shaft length. Axial loads too high. Excessive working angle and torque. 	<ul style="list-style-type: none"> Shorten shaft length (cut both telescopic tubes as well as shields and remove burrs). Replace defective yokes. Clean and grease telescopic tubes, and replace both tubes, if necessary. Replace defective yokes. Verify compatibility between shaft and working conditions (torque vs. angle). Disengage tractor driveline during cornering or when lifting or lowering the implement. Change to a larger driveline size. Replace defective yokes.
	<ul style="list-style-type: none"> Yoke ears distorted. 	<ul style="list-style-type: none"> Overload caused by high starting and peak torques. 	<ul style="list-style-type: none"> Engage driveline more carefully. Use appropriate safety devices. Replace defective yokes.
	<ul style="list-style-type: none"> Yoke ears worn or pounded. 	<ul style="list-style-type: none"> Excessive working angle. 	<ul style="list-style-type: none"> Avoid excessive working angle. Disengage tractor driveline during cornering. Replace defective yokes.

MAINTENANCE

	AVOIDABLE DAMAGES	POSSIBLE CAUSES	CORRECTIVE ACTIONS
<p><u>CROSS KIT</u></p> 	<ul style="list-style-type: none"> ◆ Cross arms broken. 	<ul style="list-style-type: none"> ◆ Extreme torque peak or shock load. ◆ Axial loads too high. 	<ul style="list-style-type: none"> ◆ Use appropriate safety device. ◆ Change to a larger driveline size. ◆ Shorten driveline shaft. ◆ Replace defective cross bearings.
	<ul style="list-style-type: none"> ◆ Bearing caps turning in their cross journal. ◆ Overheated bearing caps. 	<ul style="list-style-type: none"> ◆ Excessive continuous torque and/or excessive working angle. ◆ Inadequate greasing. 	<ul style="list-style-type: none"> ◆ Verify compatibility between shaft and working conditions. ◆ Carefully follow greasing instructions. ◆ Replace defective cross bearings.
	<ul style="list-style-type: none"> ◆ Accelerated wear of cross kit. 	<ul style="list-style-type: none"> ◆ Excessive continuous torque and/or excessive working angle. ◆ Inadequate greasing. 	<ul style="list-style-type: none"> ◆ Verify compatibility between shaft and working conditions. ◆ Carefully follow greasing instructions. ◆ Replace defective cross bearings.

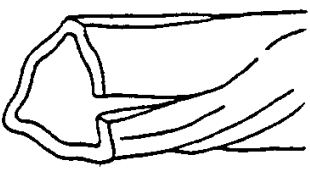
Note: Cross bearings must be greased every 8 working hours.

	AVOIDABLE DAMAGES	POSSIBLE CAUSES	CORRECTIVE ACTIONS
<p><u>TELESCOPIC TUBES</u></p>  	<ul style="list-style-type: none"> ◆ Telescopic tubes failure or twisting. 	<ul style="list-style-type: none"> ◆ Extreme torque peak or shock load. ◆ Short tube engagement. 	<ul style="list-style-type: none"> ◆ Use appropriate safety device. ◆ Change to a larger driveline size. ◆ Replace the driveline drive shaft with one having adequate length. ◆ Replace defective tubes.
	<p>Accelerated wear of telescopic tubes.</p> 	<ul style="list-style-type: none"> ◆ Extreme load when sliding. ◆ Short tube engagement. ◆ Inadequate greasing. ◆ Dirt 	<ul style="list-style-type: none"> ◆ Change to a driveline with rilsan coated inner tube. ◆ Replace the driveline with one having adequate length. ◆ Carefully follow greasing instructions. ◆ Replace defective tubes.

Note: Telescopic tubes must be cleaned and greased every 8 working hours.

MAINTENANCE

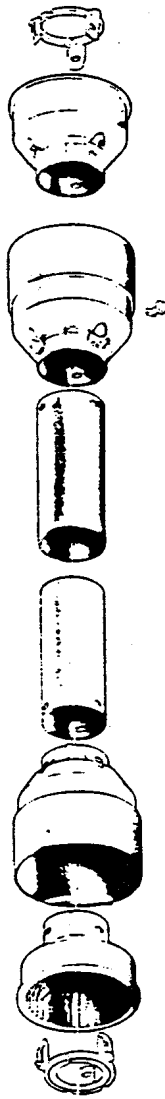
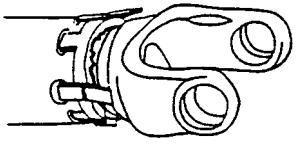
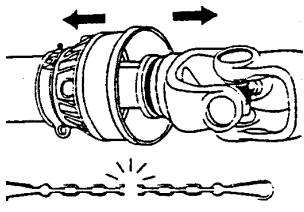
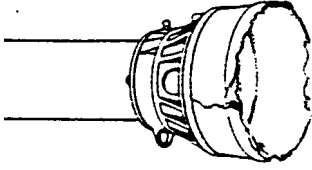
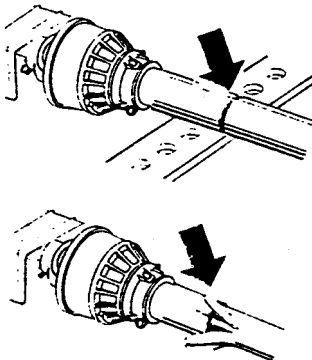
SHIELD 	AVOIDABLE DAMAGES	POSSIBLE CAUSES	CORRECTIVE ACTIONS
	<ul style="list-style-type: none"> ◆ Excessive wear of shield bearings. 	<ul style="list-style-type: none"> ◆ Insufficient lubrication. ◆ Incorrect chain mounting. ◆ Shield interfering with implement. 	<ul style="list-style-type: none"> ◆ Follow lubrication instructions. ◆ Mount chain to allow maximum angularity. ◆ Avoid contact of the shields with fixed parts of the machine or tractor. ◆ Replace shield bearings.
	<ul style="list-style-type: none"> ◆ Chain moving or failure. 	<ul style="list-style-type: none"> ◆ Shield interfering with implement. ◆ Incorrect chain mounting. 	<ul style="list-style-type: none"> ◆ Avoid contact of the shields with fixed parts of the machine or tractor. ◆ Mount chain to allow maximum angularity. ◆ Replace defective parts.
	<ul style="list-style-type: none"> ◆ Shield cone damaged. 	<ul style="list-style-type: none"> ◆ Shield cone in contact with components on the tractor and/or implement. ◆ Excessive angularity. 	<ul style="list-style-type: none"> ◆ Eliminate interference between Shield cones and any part on the tractor and/or implement. ◆ Avoid excessive angle during cornering or when lifting or lowering the implement. ◆ Replace damaged Shield cones.
<ul style="list-style-type: none"> ◆ Shield tubes damaged (deformed and split at one side). 	<ul style="list-style-type: none"> ◆ Shields in contact with components on the tractor and/or implement. ◆ Shield tubes overlap too short or no overlap at all with extended driveline. 	<ul style="list-style-type: none"> ◆ Eliminate interference between Shield cones and any part on the tractor and/or implement. ◆ Replace damaged tubes. ◆ Adjust Shield tubes length with longer tubes. 	

Note: Shield bearings must be greased every 8 working hours.

PARTS

INTRODUCTION

All parts are illustrated in "exploded views" which show the individual parts in their normal relationship to each other. Reference numbers are used in the illustrations. These numbers correspond to those in the "Reference Number" (REF) column, and are followed by the description and quantity required.

Right Hand and Left Hand are determined by those seen by the conductor standing behind the equipment.

The manufacturer reserves the rights to change, modify, or eliminate from time to time, for technical or other reasons, certain or all data, specifications, or the product or products themselves, without any liability or obligation.

The parts listed here are available through your local dealer.

MANUAL HOLDER

REF.	DESCRIPTION	QTY	PART #
1	Manual holder	1	5RD4200030
2	Bolt hex. 5/16" NC x 1" lg gr. 5, PTD	2	5RD0100019
3	Nylon insert locknut 5/16" NC, PTD	2	5RD1000005

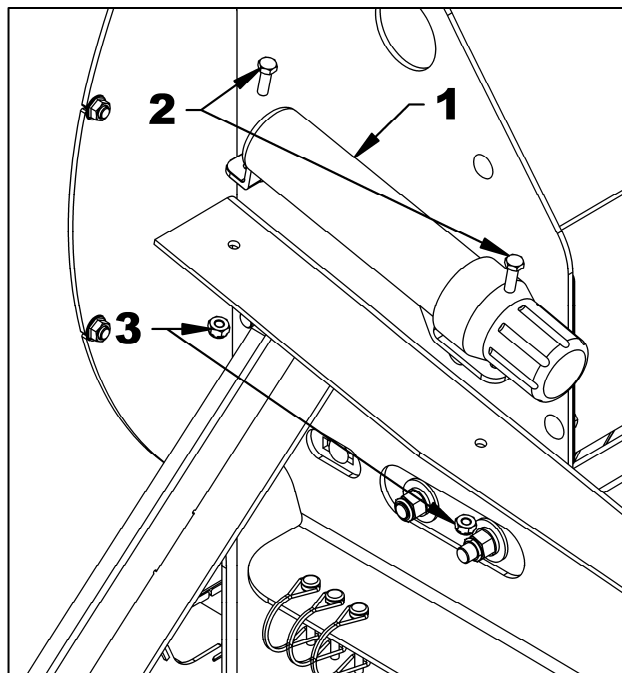

PARTS

DEBRIS BLOWER – HOUSING

REF.	DESCRIPTION	QTY	PART #
1	Housing	1	5RD669547
2	Belt shield	1	5RD669556
3	Lateral bracket	1	5RD669573
4	Carriage bolt $\varnothing 3/8$ "NC x $3/4$ " Gr.5 PTD	6	5RD0300007
5	Carriage bolt $\varnothing 1/2$ "NC x $1\ 3/4$ " Gr.5 PTD	10	5RD0300025
6	Serrated flange nut $\varnothing 3/8$ "NC PTD	6	5RD0900035
7	Nylon insert locknut $1/2$ "NC, PTD	10	5RD1000011
8	Lockwasher $1/2$ ", PTD	10	5RD1200006
9	Flat washer $\varnothing 9/16$ " int., PTD	6	5RD1400006

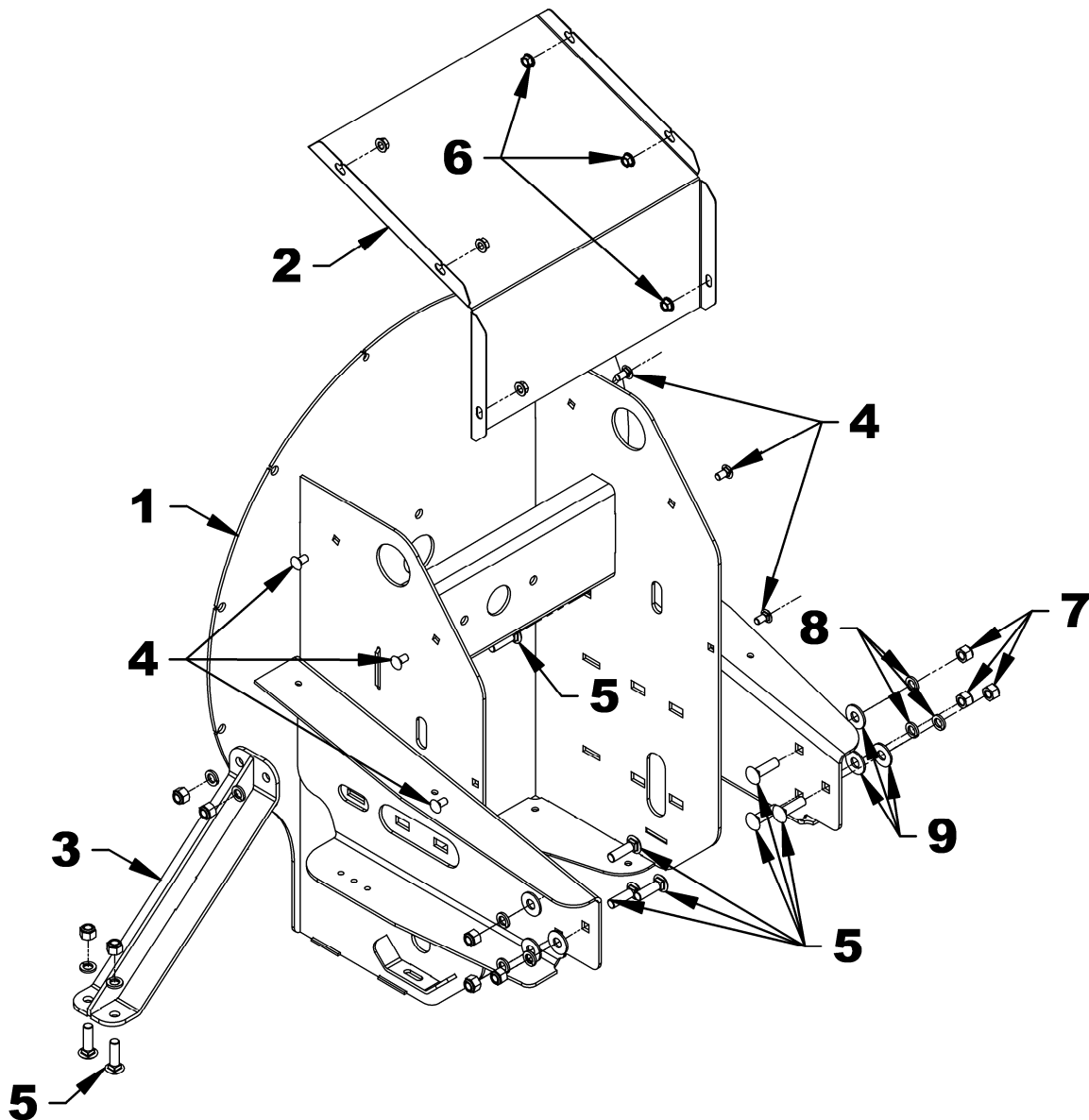

PARTS

DEBRIS BLOWER – DRUM

REF.	DESCRIPTION	QTY	PART #
1	Impeller housing	1	5RD669548
2	Intake cover	1	5RD669550
3	Orientation deflector	1	5RD669553
4	Angling arm	1	5RD669554
5	SMV reflective sign	1	5RD4200029
6	Bolt serrated flange $\varnothing 3/8$ "NC x $3/4$ " Gr.5 PTD	3	5RD0200066
7	Bolt hex. $\varnothing 1/4$ "NC x 1" Gr.5 PTD	2	5RD0100004
8	Flat washer $\varnothing 5/16$ " int., PTD	4	5RD1400002
9	Nylon insert locknut $1/4$ "NC, PTD	2	5RD1000003
10	Serrated flange nut $\varnothing 3/8$ "NC PTD	12	5RD0900035
11	Cotter pin $3/16$ " x $1 1/4$ "	1	5RD1500012

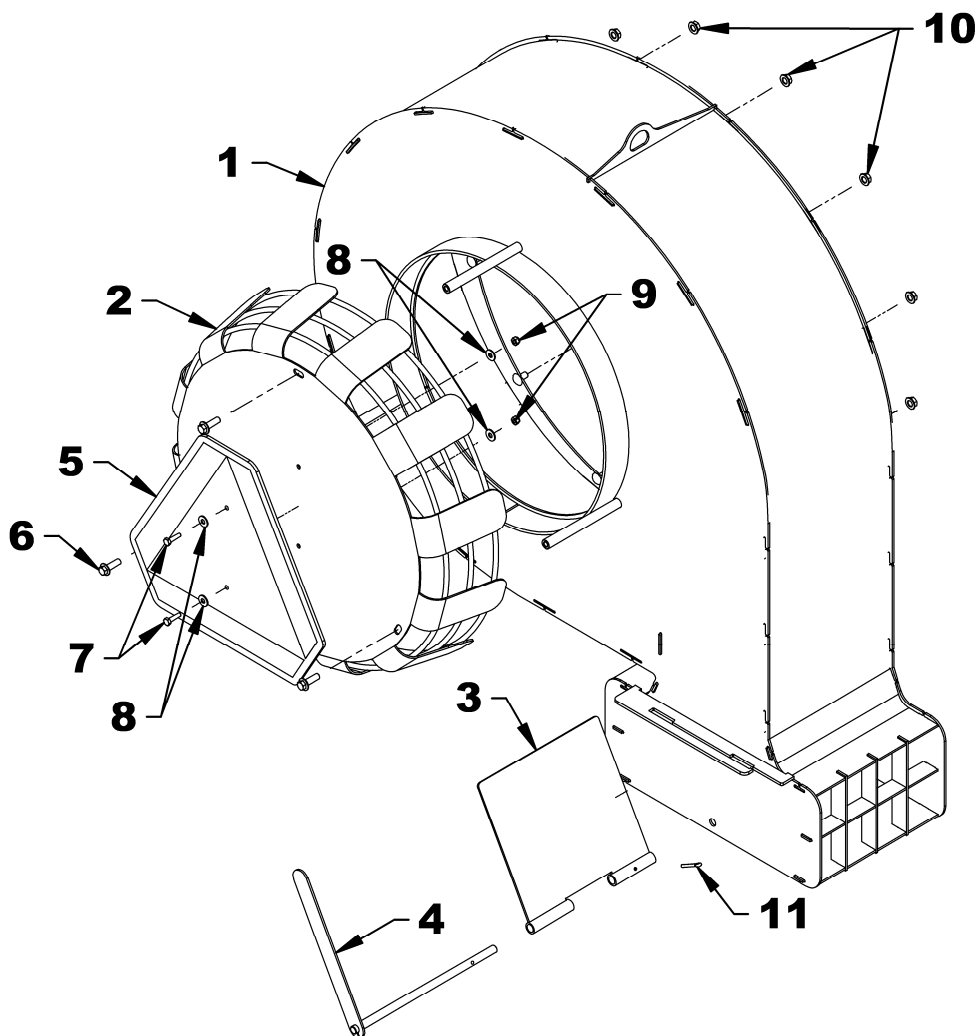

PARTS

DEBRIS BLOWER – BELT DRIVE

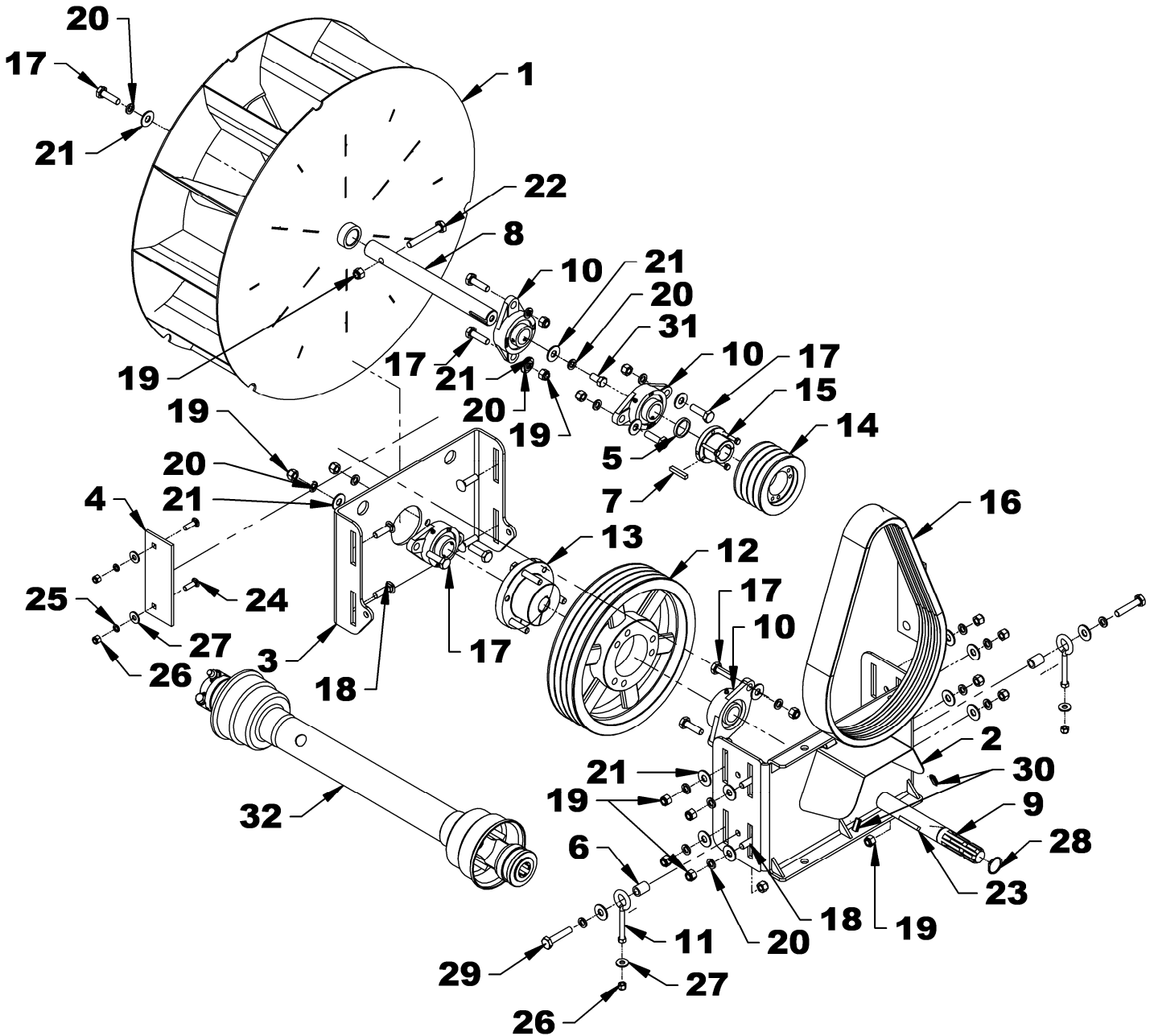

PARTS

DEBRIS BLOWER – BELT DRIVE

REF.	DESCRIPTION	QTY	PART #
1	CCW impeller	1	5RD669549
2	Rear bearing support	1	5RD669551
3	Front bearing support	1	5RD669552
4	Tension guide	2	5RD669576
5	Spacer ring - Upper shaft	1	5RD669571
6	Bushing - Tensioner	2	5RD669572
7	Key 5/16" x 5/16" x 1 3/4"	1	5RD661166
8	Driven shaft 1 3/8"	1	5RD669559
9	Drive shaft 1 3/8" 6 splines	1	5RD669558
10	Bearing 1 3/8" with setscrew	4	5RD4300019
11	Eye bolt 3/8" NC x 5" (Hex. nut 3/8" NC included)	2	5RD661426
12	Pulley 14" diam., "4V", TYPE "5V"	1	5RD4800020
13	Hub Type E-1 3/8" dia.	1	5RD4800021
	<i>Including: Hex bolt 1/2"NC x 2 3/4" Gr.5 "full thread"</i>	3	-
	<i>Lockwasher ø 1/2" PTD</i>	3	-
	<i>Set screw 3/8"NC x 3/8"</i>	1	-
14	Pulley 5.2" diam., "4V", TYPE "5V"	1	5RD4800022
15	Hub Type SD-1 3/8" dia.	1	5RD4800023
	<i>Including: Hex bolt 1/4"NC x 2" Gr.5 "full thread"</i>	3	-
	<i>Lock washer ø 1/4" PTD</i>	3	-
	<i>Set screw 1/4"NC x 1/4"</i>	1	-
16	Belt "Power Band" 4-R5VX560	1	5RD4800024
17	Bolt hex. 1/2"NC x 1 3/4" Gr.5 PTD	9	5RD0100071
18	Carriage bolt ø1/2"NC x 1 3/4" Gr.5 PTD	8	5RD0300025
19	Nylon insert locknut 1/2"NC, PTD	19	5RD1000011
20	Lockwasher 1/2", PTD	20	5RD1200006
21	Flat washer ø9/16" int., PTD	20	5RD1400006
22	Bolt hex. 1/2"NC x 3 1/2" Gr.5 PTD	1	5RD0100079
23	Key 5/16" x 5/16" x 2 1/8"	1	5RD669582
24	Carriage bolt ø3/8"NC x 1 1/4" Gr.5 PTD	4	5RD0300009
25	Lockwasher 3/8", PTD	4	5RD1200004
26	Nylon insert locknut 3/8"NC, PTD	6	5RD1000006
27	Flat washer ø7/16" int., PTD	6	5RD1400004
28	Retaining ring	1	5RD4300068
29	Bolt hex. 1/2"NC x 2 1/2" Gr.5 PTD	2	5RD0100076
30	Protective rubber	2	5RD669348
31	Bolt hex. 1/2"NC x 1" Gr.5 PTD	1	5RD0100068
32	Driveline	1	5RD4700159

PARTS

DEBRIS BLOWER – HITCH AND WHEELS

REF.	DESCRIPTION	QTY	PART #
1	Hitch and wheels support	1	5RD669557
2	Wheels support	3	5RD669555
3	Chain 35" lg. with springhook	1	5RD669210
4	Spacer 1.015" ID x 1" lg.	6	5RD661119
5	Wheel bushing	3	5RD669560
6	Wheel and rim	3	5RD660658
7	Hitch pin cat. 1 & 2, PTD	2	5RD654204
8	Pin 3/4" x 5 7/16", PTD	1	5RD4600051
9	Bushing 1 1/4 " ext. x 2-13/32" lg x .770" int. PTD	1	5RD669211
10	Bushing 1.135" int. x 1 1/2" ext. x 2 15/16" lg	2	5RD668379
11	Linchpin 7/16", PTD	3	5RD1900003
12	Round wire lock pin 1/4" x 1 3/4"	3	5RD1900006
13	Spring pin 3/8" x 1 1/2", black	2	5RD1600022
14	Cotter pin 1/4" x 2"	3	5RD1500022
15	Flat washer ø1 1/4" int., PTD	3	5RD1400014
16	Bolt hex. Ø5/8"NC x 7" Gr.5 PTD	3	5RD0100109
17	Nylon insert locknut 5/8"NC, PTD	3	5RD1000012
18	Flat washer ø11/16" int., PTD	3	5RD1400008
19	Grease fitting 1/4NF	3	5RD654106

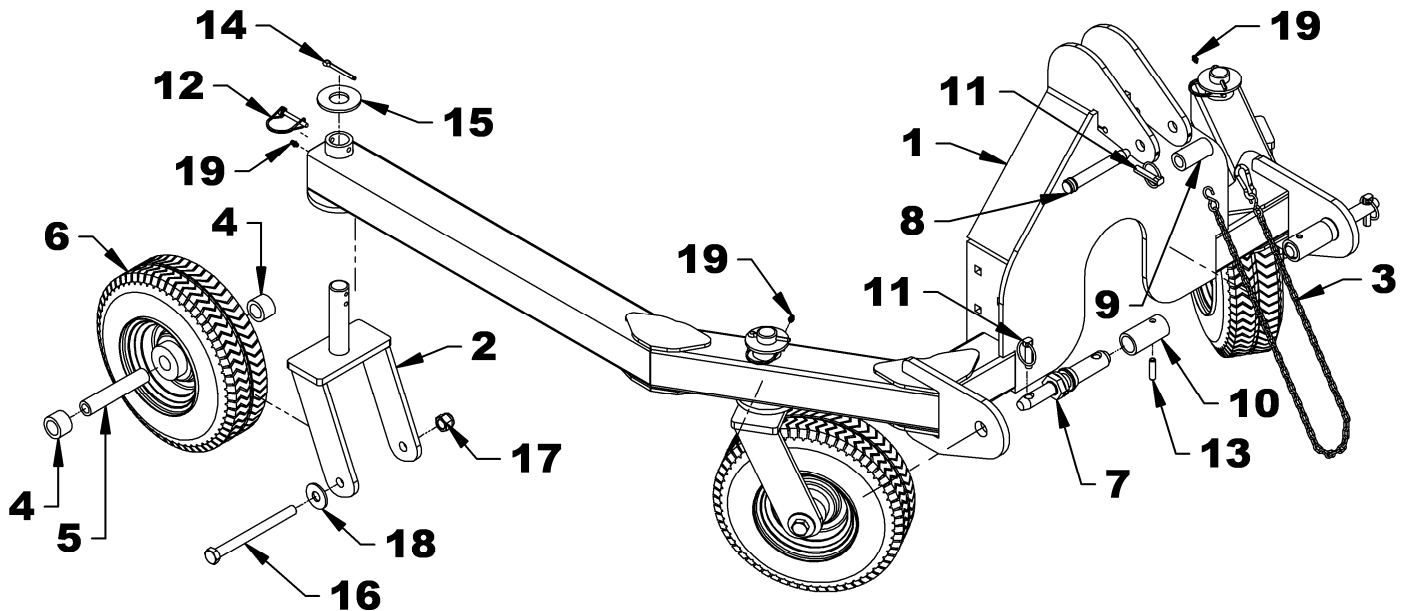

PARTS

DRIVELINE 5RD4700159

REF.	DESCRIPTION	QTY	PART #
1	Yoke ass'y	1	5RD660764
2	Journal cross	2	5RD660765
3	Yoke for female tube	1	5RD663189
4	Female tube	1	5RD4700160
5	Male tube	1	5RD4700161
6	Yoke for male tube	1	5RD663193
7	Yoke ass'y	1	5RD4700058
8	Shear bolt M12 x 1.25 x 70 with nut	2	5RD662199
9	Grease fitting	1	5RD663129
10	Ball Ø1/4"	23	5RD663163
11	Shear bolt 8mm x 1.25 x 50 gr.5.8 and nut	1	5RD4700060
12	Protector and chain	1	5RD4700164
13	Pin for outer tube	1	5RD4700061
14	Pin for inner tube	1	5RD4700062

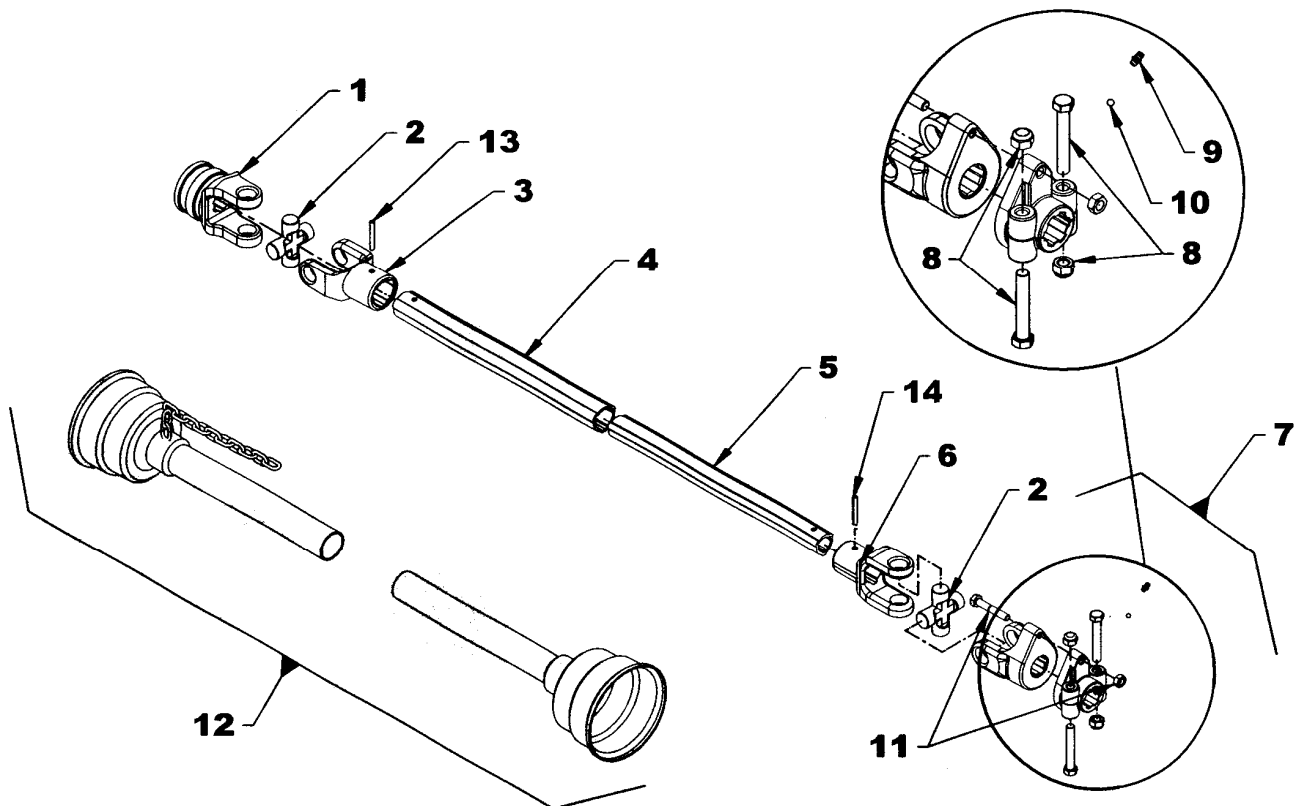







TORQUE SPECIFICATION TABLE





GENERAL SPECIFICATION TABLE

Use the following torques when special torques are not given

NOTE: These values apply to fasteners as received from supplier, dry, or when lubricated with normal engine oil. They do not apply if special graphited or moly sidulphide greases or other extreme pressure lubricants are used. This applies to both UNF and UNC threads.

SEE Grade No.		2				5				8			
BOLT HEAD IDENTIFICATION MARKS AS PER GRADE NOTE: MANUFACTURING MARKS WILL VARY.						  				  			
BOLT SIZES		Torque				Torque				Torque			
Inches	Millimeters	Pounds-Foot		Newtons-Meter		Pounds-Foot		Newtons-Meter		Pounds-Foot		Newtons-Meter	
		MIN.	MAX.	MIN.	MAX.	MIN.	MAX.	MIN.	MAX.	MIN.	MAX.	MIN.	MAX.
1/4	6.35	5	6	6.8	8.13	9	11.0	12.2	14.9	12	15	16.3	30.3
5/16	7.94	10	12	13.6	16.3	17	20.5	23.1	27.8	24	29	32.5	39.3
3/8	9.53	20	23	27.1	31.2	35	42.0	47.5	57.0	45	54	61.0	73.2
7/16	11.11	25	30	40.7	47.4	54	64.0	73.2	86.8	70	84	94.9	113.9
1/2	12.70	45	52	61.0	70.5	80	96.0	108.5	130.2	110	132	149.2	179.0
9/16	14.29	65	75	88.1	101.6	110	132.0	149.2	179.0	160	192	217.0	260.4
5/8	15.88	95	105	128.7	142.3	150	180	203.4	244.1	220	264	298.3	358.0
3/4	19.05	150	185	203.3	250.7	270	324	366.1	439.3	380	456	515.3	618.3
7/8	22.23	160	200	216.8	271.0	400	480	542.4	650.9	600	720	813.6	976.3
1	25.40	250	300	338.8	406.5	580	696	786.5	943.8	900	1080	1220.4	1464.5
1 1/8	25.58	-	-	-	-	800	880	1084.8	1193.3	1280	1440	1735.7	1952.6
1 1/4	31.75	-	-	-	-	1120	1240	1518.7	1681.4	1820	2000	2467.9	2712.0
1 3/8	34.93	-	-	-	-	1460	1680	1979.8	2278.1	2380	2720	3227.3	3688.3
1 1/2	38.10	-	-	-	-	1940	2200	2630.6	2983.2	3160	3560	4285.0	4827.4

METRIC BOLT TORQUE SPECIFICATIONS

Size of screw	Grade No.	Pitch mm	Coarse thread				Pitch mm	Fine Thread			
			Pounds-Foot		Newtons-Meter			Pounds-Foot		Newtons-Meter	
			MIN.	MAX.	MIN.	MAX.		MIN.	MAX.	MIN.	MAX.
M6	4T 	1.0	3.6	5.8	4.9	7.9	-	-	-	-	
	7T 		5.8	9.4	7.9	12.7	-	-	-	-	
	8T  		7.2	10	9.8	13.6	-	-	-	-	
M8	4T	1.25	7.2	14	9.8	19.0	12	17	16.3	23.0	
	7T		17	22	23	29.8	19	27	25.7	36.6	
	8T		20	26	27.1	35.2	22	31	29.8	42	
M10	4T	1.5	20	25	27.1	33.9	20	29	27.1	39.3	
	7T		34	40	46.1	54.2	35	47	47.4	63.7	
	8T		38	46	51.5	62.3	40	52	54.2	70.5	
M12	4T	1.75	28	34	37.9	46.1	31	41	42	55.6	
	7T		51	59	69.1	79.9	56	68	75.9	92.1	
	8T		57	66	77.2	89.4	62	75	84	101.6	
M14	4T	2.0	49	56	66.4	75.9	52	64	70.5	86.7	
	7T		81	93	109.8	126	90	106	122	143.6	
	8T		96	109	130.1	147.7	107	124	145	168	
M16	4T	2.0	67	77	90.8	104.3	69	83	93.5	112.5	
	7T		116	130	157.2	176.2	120	138	162.6	187	
	8T		129	145	174.8	196.5	140	158	189.7	214.1	
M18	4T	2.0	88	100	119.2	136	100	117	136	158.5	
	7T		150	168	203.3	227.6	177	199	239.8	269.6	
	8T		175	194	237.1	262.9	202	231	273.7	313	
M20	4T	2.5	108	130	146.3	176.2	132	150	178.9	203.3	
	7T		186	205	252	277.8	206	242	279.1	327.9	
	8T		213	249	288.6	337.4	246	289	333.3	391.6	

**PART NO.
5RDBL1130A**



All Rights Reserved

Free Manuals Download Website

<http://myh66.com>

<http://usermanuals.us>

<http://www.somanuals.com>

<http://www.4manuals.cc>

<http://www.manual-lib.com>

<http://www.404manual.com>

<http://www.luxmanual.com>

<http://aubethermostatmanual.com>

Golf course search by state

<http://golfingnear.com>

Email search by domain

<http://emailbydomain.com>

Auto manuals search

<http://auto.somanuals.com>

TV manuals search

<http://tv.somanuals.com>