

95-147 KW (128-198 NET HP)



**JOHN DEERE**

**K**

**LOADERS**

444K | 524K | 544K | 624K



**UTILITY LOADERS**



# Think. Again.

Innovative Quad-Cool™ system. Highly reliable solid-state electrical system and sealed-switch module. Smooth-as-silk SmartShift™ transmission. The J-Series Loaders introduced a lot of innovative thinking — and began a tradition that continues in the new K-Series. Although they don't appear all that different from their standard-setting predecessors, these next-generation loaders are loaded throughout with even more customer-inspired

enhancements. Spacious, quieter cabs with unsurpassed visibility. Expanded sealed-switch modules. Secured key-less start. And easier-to-read LCD monitors with advanced onboard diagnostics. You have more choices, too, including the 2.1-m<sup>3</sup> (2.75 cu. yd.) 524K, NeverGrease™ pins, and automatic diff-lock axles, to list just a few. Exceptional productivity, long-term durability, unparalleled versatility — you get it all in the John Deere K-Series.



## K-SERIES SPECIFICATIONS

	444K	524K	544K	624K
<b>Rated Net Power</b>	95 kW (128 hp)	110 kW (146 hp)	125 kW (167 hp)	147 kW (198 hp)
<b>Bucket Capacity</b>	1.9 m <sup>3</sup> (2.5 cu. yd.)	2.1 m <sup>3</sup> (2.75 cu. yd.)	2.3 m <sup>3</sup> (3.0 cu. yd.)	2.7 m <sup>3</sup> (3.5 cu. yd.)
<b>Z-bar:</b>				
<b>Tipping Load</b> 40-degree full turn	8072 kg (17,796 lb.)	8935 kg (19,698 lb.)	9434 kg (20,799 lb.)	12 031 kg (26,542 lb.)
<b>Breakout Force</b>	8023 kg (17,688 lb.)	9193 kg (20,267 lb.)	10 188 kg (22,461 lb.)	12 920 kg (28,484 lb.)
<b>Operating Weight</b>	11 055 kg (24,372 lb.)	12 282 kg (27,077 lb.)	12 820 kg (28,263 lb.)	15 185 kg (33,477 lb.)
<b>Powerlifel™:</b>				
<b>Tipping Load</b> 40-degree full turn	6226 kg (13,726 lb.)	N/A	7554 kg (16,654 lb.)	9257 kg (20,408 lb.)
<b>Breakout Force</b>	6056 kg (13,352 lb.)	N/A	8604 kg (18,968 lb.)	10 759 kg (23,719 lb.)
<b>Operating Weight</b>	12 074 kg (26,619 lb.)	N/A	13 840 kg (30,511 lb.)	16 454 kg (36,275 lb.)
<b>Tool Carrier:</b>				
<b>Tipping Load</b> 40-degree full turn	N/A	N/A	N/A	10 739 kg (23,675 lb.)
<b>Breakout Force</b>	N/A	N/A	N/A	10 978 kg (24,202 lb.)
<b>Operating Weight</b>	N/A	N/A	N/A	15 499 kg (34,169 lb.)

PowerTech™ EPA Tier 3/EU Stage IIIA diesels pack impressive torque reserves that top out at a whopping 55 percent in the 624K. For power without compromise in all conditions.

K-Series Loaders ride on a wide stance that provides additional lateral stability for handling heavy loads and working on rough terrain. Overall balance is exceptional.

Same-side ground-level service access makes the daily routine quick and easy. Enhanced onboard diagnostics and extended service intervals further maximize uptime.

Z-bar or parallel lift? If you can't decide which configuration is best for you, the 444K, 544K, and 624K Powerlifel's patented design delivers the best of both.

Available premium heated air-ride armchair seat adjusts multiple ways for extra comfort and cushioning.

Spacious cab with a cooler compartment and beverage holder provides plenty of room to stow your stuff. Convenient 12-volt port powers cell phones and other electronic devices.

Brake and throttle pedals have been repositioned and the front console redesigned to make way for more legroom and comfort.

Adjustable automotive-style louvers provide effective airflow to keep the glass clear and pressurized cab comfortable.



1

1. Multilanguage color LCD monitor provides pushbutton access to a wealth of machine info and control:
  - A. **Vital and general operating information**, including transmission mode, gear, engine rpms, and ground speed.
  - B. **Enhanced onboard diagnostics** with speed, pressure, and temperature readings and real-time switch status.
  - C. **Customized machine settings** such as Quick Shift, Auto-to-1st, and ride control. Lets you match operating characteristics to specific jobs and conditions.
  - D. **Optional embedded payload scale** weighs each bucket load, helping fill trucks to the max.



2

2. Joystick steering (available on 544K/624K) is ideal for V-pattern truck loading. Offering fatigue-beating comfort, it adapts to ground speed, delivering smooth control for load-and-carry applications, as well.
3. Key-less start security system requires a numeric pass code (when enabled). Helps prevent unauthorized machine operation.
4. Optional rearview camera and radar object-detection system provides "eyes-in-the-back-of-the-head" visibility, displaying the activity out back on the LCD screen. Emits an audible alert, too, for extra awareness in tight quarters and high-traffic areas.

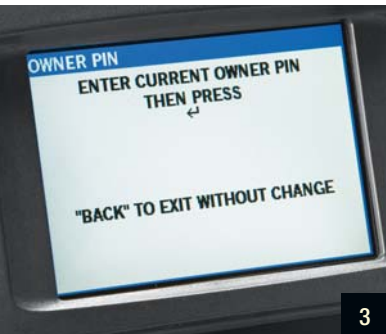

3



4





# Hard work made easier.

What operator wouldn't be more productive in the high-back air-ride seat of a K-Series Loader? Upfront, an enhanced multifunction monitor displays operating, diagnostic, and maintenance info on a color LCD screen with easy-on-the-eyes clarity. Ten-percent more tinted glass and a low-profile console allow a commanding view

of the work ahead. The quieter cab boasts more legroom and improved ergonomics, too, including fatigue-beating features like seat-mounted loader controls. And an expanded sealed-switch module with key-less start and easy pushbutton operation of even more functions. For more productivity without extra effort.

# More power and control mean more productivity.



If you've got maximum productivity in mind, the K-Series Loaders should be at the top of your list. But it's not just their big torque reserves that make them such impressive performers. Single-lever joystick or two-lever fingertip controls provide smooth, near-effortless control. Excavator-style hydraulics sense

the load and deliver the flow needed for smooth combined functions and fast work cycles. You won't find a smoother-shifting loader, either. The PowerShift™ torque-converter transmission employs SmartShift technology to continuously evaluate speed and load conditions, and adjusts clutch-pack engagement to suit.



SmartShift ensures that gear changes are smooth as silk, regardless of whether the bucket is empty or fully loaded.

Engine/hydraulic match maintains good boom and bucket power into and out of the pile. For big loads, even in wet or packed materials.

Optional spin control boosts productivity by improving traction in troublesome material or underfoot conditions. Reduces tire wear, fuel costs, and operator fatigue, too.

Responsive steering and full 80-degree articulation increase maneuverability in tight quarters, for faster cycle times and fewer three-point turns.

Hydraulic system provides only the power required, so there's no wasted horsepower or fuel.

Boom-height kick-out and return-to-carry functions help speed production in repetitive loading applications. On Powerllec-equipped loaders, the touchpad has two presets for added convenience when frequent attachment changeover is required.



1. Choose from single-lever joystick or two-lever fingertip pilot-operated hydraulic controls. Joystick FNR selector provides convenient direction and full-range gear changes. Both include innovative Quick-Shift feature for pushbutton gear changes, one gear at a time.

2. Backlit touchpad in the expanded sealed-switch module controls key-less start and 24 other machine functions. Enables the operator to adjust boom-height kick-out and return-to-carry, and activate return-to-dig from the seat.

3. Programmable clutch cutoff increases productivity in all kinds of terrain. Simply select the slope of your dumpsite — level, small, or steep. Depressing the brake pedal disconnects the transmission while maintaining engine speed for fast boom cycles.



Powerllel's unique design separates the bell crank from the cross tube, attaching instead to the loader frame via a Y-shape link. This "free-floating" bell-crank design allows load forces to work with, not against, the boom. For powerful breakout in tough digging.

Coupler fastens the attachment close to the machine to optimize stability with heavy loads.

Unique Y-link, low-mounted boom cylinders, and Hi-Vis coupler provide clear visibility to the work tool and throughout the lift arc.

Tire and axle options let you equip your Powerllel loader for material-handling work on a wide variety of terrain.



2



3

1. If it's a traditional tool carrier you want, the 624K delivers parallel lift, plus numerous other K-Series advantages.
2. Hi-Vis coupler lets you change attachments from the cab quickly and easily. Conforms to ISO23727, allowing it to pick up a broad range of John Deere and other attachments so you can do more with one machine.
3. Powerllel loaders deliver outstanding breakout throughout the entire bucket and angle range. To conquer tough tasks such as loading logs.







# Parallel lift that's simply unparalleled.

Powerllel loaders deliver both powerful digging forces and parallel lift. Their innovative design allows load forces to work with, not against, the boom. For big breakout force, even in difficult digging. Impressive torque throughout the entire dump and rollback range enables Powerllel loaders to excel at

a wide variety of material-handling tasks. But don't just look for these John Deere advantages in the numbers on a spec sheet. The best way to fully appreciate them is on your jobsite. Whatever the task, whatever the load, you'll discover parallel lift that's without parallel.



# Discover your options.

K-Series Loaders come equipped with plenty of production-boosting features to help you handle almost anything you throw their way. But if yours isn't just any application, we've got you covered

with a wide variety of factory- or dealer-installed options. So you can equip your loader with exactly what you need to maximize your efforts and expand your opportunities.



Corrosion package shields electrical components and connections to help prevent corrosive materials from short-circuiting productivity.

Full-tire front and rear fenders and flaps help keep the machine free of mud and debris.

Powered cab pre-cleaner is a smart addition in high airborne-debris environments.

Heated mirrors prevent fog and ice from obstructing the view and affecting productivity.

JDLink™ lets you know where your loader is and how it's performing. This wireless communication system delivers location, performance, and maintenance data to your computer.

Embedded payload scale enables you to fill each truck to its limit for maximum productivity. It's available on all Z-bar and high-lift loaders.

General-purpose or excavating buckets are available in pin-on or coupler configurations from 1.9–2.7 m<sup>3</sup> (2.0–3.5 cu. yd). Or opt for the 1.5- or 2.29-m (60 or 90 in.) wide forks with 1.22- or 1.52-m (48 or 60 in.) tines.

Need to take productivity to another level? High-lift option (not available on 524K) extends lift height nearly 381 mm (15 in.).

Axle choices include front and rear locking differentials or front locking differential with conventional rear.

Rear-axle disconnect disengages power when not needed. Reduces fuel consumption and tire wear, and helps smooth the ride during roading or transport.

**1.** With ride control, the lift cylinders act as shock absorbers, cushioning bumps to allow these loaders to navigate rough ground more quickly without losing their loads. Auto-actuation travel speed is adjustable between 3.2 and 24.1 km/h (2 and 15 mph).

**2.** Worksite Pro™ couplers increase versatility and make attachment switchover push-button easy. Hi-Vis coupler conforms to ISO23727, allowing it to pick up a broad range of John Deere and other attachments.

**3.** Automatic differential lock engages as soon as a tire begins to slip. It's ideal for inexperienced operators or applications requiring high traction, such as stockpiling silage, plowing snow, and handling pipe.

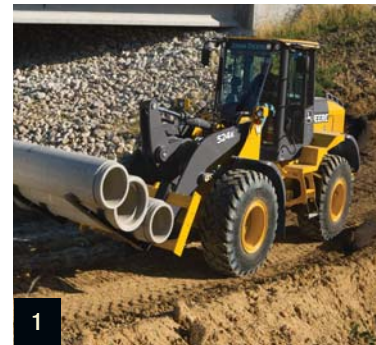

Four steel plates support the loader tower, extending pin life and protecting the boom-cylinder hoses.

Sealed-switch module keeps out dust, moisture, and debris, and virtually never wears out. Proven marine-grade touchpad eliminates rocker switches and nearly 100 wires, and unsealed connections provide even longer life.

Standard features such as bypass-start protection, automatic park brake, convenient handholds, and slip-resistant steps help keep the operator out of harm's way.

Wet-sleeve engine liners provide uniform engine cooling for less oil breakdown and longer durability than cast-in-block designs.

500-, 2,000-, and 4,000-hour engine, transmission, and hydraulic oil and filter service intervals mean more uptime.

Wide-mouth fuel tank allows quick and convenient ground-level fill-ups. Generous capacity lets you work longer.

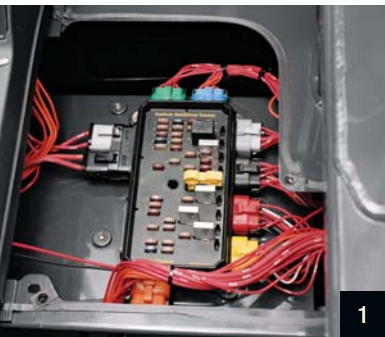

1. Electrical-distribution center employs highly reliable circuit-board technology and solid-state switches that eliminate numerous wiring harnesses, fuses, relays, and connectors. Sealed gold-pin electrical connectors resist corrosion for superior long-term integrity.



2. 524K, 544K, and 624K planetary final drives are mounted inboard. Hydraulic wet-disc brakes on all models self-adjust.



3. Quad-Cool places the radiator, air-conditioner condenser, intercooler, and hydraulic, transmission, and optional axle coolers in a unique boxed configuration that's isolated from engine heat. For increased efficiency and durability.



4. Optional programmable fan automatically reverses at predetermined intervals, ejecting debris from the radiator and cooler cores. Or choose your own cleaning cycles through the monitor.





# Nothing Runs Like a Deere.

It's all about uptime. So we gave the K-Series plenty of resources to help them succeed. All four loaders come equipped with traditional John Deere durability features. Such as heavy-duty wet-sleeve diesels, Quad-Cool, and solid-

state electrical systems. Reinforced articulation joints with double-tapered roller bearings. Plus, booms and mainframes so tough they're warranted for three years or 10,000 hours. When you know how they're built, you'll run a Deere.

Greasing is less messy, with centralized lube banks providing easy access to difficult-to-reach zerks. Conveniently located periodic lube and maintenance chart ensures that nothing gets overlooked.

Inboard planetary final drives and self-adjusting wet-disc brakes on 524K–624K are virtually maintenance-free.

Hydraulically driven fan runs only as needed for efficient cooling. Helps conserve precious fuel, too.

All daily service points including fuel are grouped on the left side for quick and convenient ground-level access.

Three-millimeter side-shield perforations block most airborne debris. Unlike stacked coolers, Quad-Cool cores resist plugging and are easily accessible from either side for quick and easy cleanout.

Auto-idle applies the brakes and automatically reduces engine speed to help conserve fuel after an operator-determined period of inactivity. Auto shutdown turns off the engine after extended inactivity.



# Stretches your dollars, not your service techs.

Controlling daily owning and operating costs shouldn't be a reach — and it's not on a K-Series Loader. Ground-level same-side service points make quick work of the daily routine. Unique Quad-Cool system provides wide-open access to both sides of the coolers for easy cleanout. Extended service intervals let you work longer between changes. And because no

maintenance beats low maintenance, available NeverGrease loader pins, standard self-adjusting serpentine engine belts, and wet-disc brakes seldom, if ever, require attention. That's just for starters. The list of K-Series features that help minimize maintenance goes on and on. And so will the owning and operating cost savings you'll enjoy.

1. Vertical spin-on filters allow quick, no-spill changes. 500-, 2,000- and 4,000-hour engine, transmission, and hydraulic oil service intervals help reduce operating costs.
4. Color-coded fluid-sample and diagnostic test ports help speed preventative maintenance and troubleshooting. Noninvasive design helps keep out contaminants.



2. NeverGrease joints eliminate numerous zerks and the daily attention they require. Available on the 544K and 624K, this exclusive option delivers consistent, extended pin life.
5. Conveniently located, easy-to-read sight gauges and see-through reservoirs let you check transmission, hydraulic, coolant, and windshield washer fluid levels at a glance.

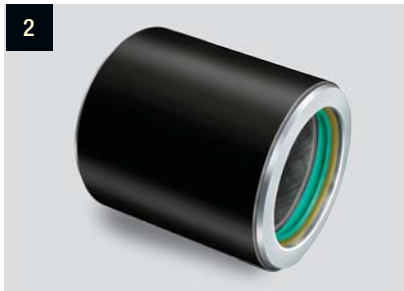

3. If something goes wrong, the easy-to-navigate LCD monitor displays diagnostic messages, and even offers possible solutions to help get you back up and running quickly.
6. Lockable compartment swings open, offering convenient ground-level access to batteries and electrical-disconnect switch.

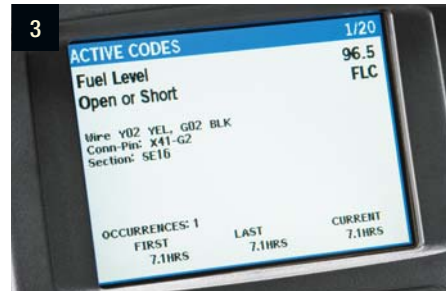

# Specifications

444K

DEERE

## Engine 444K Z-BAR / HIGH-LIFT / POWERLLEL™

Manufacturer and Model	John Deere PowerTech™ E 4045H
Non-Road Emissions Standard	EPA Tier 3/EU Stage IIIA
Cylinders	4
Valves Per Cylinder	2
Displacement	4.5 L (276 cu. in.)
Net Peak Power @ 2,100 rpm	95 kW (128 hp)
Net Peak Torque @ 1,400 rpm	515 Nm (380 lb.-ft.)
Net Torque Rise	32%
Fuel System (electronically controlled)	high-pressure common rail
Lubrication	full-flow spin-on filter and integral cooler
Aspiration	turbocharged, charge air cooled
Air Cleaner	under-hood, dual-element dry type, restriction indicator in cab monitor for service
Fan Drive	hydraulically driven, proportionally controlled, fan aft of coolers
Electrical System	24 volt with 80-amp alternator (100-amp alternator optional)
Batteries (2 – 12 volt)	950 CCA (each)

## Transmission

Type	countershaft-type PowerShift™	
Torque Converter	single stage, single phase	
Shift Control	electronically modulated, adaptive, load and speed dependent	
Operator Interface	steering-column or joystick-mounted F-N-R and gear-select lever; kick-down button on hydraulic lever	
Shift Modes	manual/auto (1st-D or 2nd-D); quick-shift button with 2 selectable modes: kick-down or kick-up/down; and 3 adjustable clutch-cutoff settings	
Travel Speeds (with 17.5 R 25 tires)	<i>Forward Maximum</i>	<i>Reverse Maximum</i>
Gear 1	7.3 km/h (4.5 mph)	7.6 km/h (4.7 mph)
Gear 2	12.1 km/h (7.5 mph)	13.0 km/h (8.1 mph)
Gear 3	23.1 km/h (14.4 mph)	25.3 km/h (15.7 mph)
Gear 4	36.0 km/h (22.4 mph)	N/A

## Axles/Brakes

Final Drives	heavy-duty midboard-mounted planetary
Differentials	hydraulic locking front with conventional rear — standard; dual locking front and rear — optional
Rear Axle Oscillation, Stop to Stop (with 17.5 R 25 tires)	24 deg.
Brakes (conform to ISO 3450)	
Service Brakes	hydraulically actuated, midboard final-drive carrier mounted, oil cooled, self-adjusting retractors, multi disc
Parking Brake	automatic spring applied, hydraulically released, driveline mounted, oil cooled, multi disc

## Tires

Choice of (with 3-piece rims)*	Tread Width	Width Over Tires	Change In Vertical Height
17.5 R 25, 1 Star L-3	1900 mm (74.8 in.)	2415 mm (95.1 in.)	standard
17.5 R 25, 1 Star L-2	1900 mm (74.8 in.)	2425 mm (95.5 in.)	- 5 mm (- 0.2 in.)
17.5-25, 12 PR L-3	1900 mm (74.8 in.)	2406 mm (94.7 in.)	+ 5 mm (+ 0.2 in.)
17.5-25, L-2 <sup>†</sup>	1900 mm (74.8 in.)	2406 mm (94.7 in.)	+ 5 mm (+ 0.2 in.)
17.5-25, L-2	1900 mm (74.8 in.)	2406 mm (94.7 in.)	+ 5 mm (+ 0.2 in.)
20.5-25, 12 PR L-2 <sup>§</sup>	1950 mm (76.8 in.)	2539 mm (100.0 in.)	+ 66 mm (+ 2.6 in.)
20.5-25, 1 Star L-2 <sup>§</sup>	1950 mm (76.8 in.)	2533 mm (99.7 in.)	+ 58 mm (+ 2.3 in.)
550/65 R 25, 1 Star L-2 <sup>§</sup>	1950 mm (76.8 in.)	2553 mm (100.5 in.)	+ 28 mm (+ 1.1 in.)

\*Based on Z-bar machine configuration; may change based on vehicle configuration, weight, or tire-pressure adjustments.

<sup>†</sup>Equipped with one-piece rims.

<sup>§</sup>CaCl<sub>2</sub> not recommended.



## Refill Capacities (U.S.)

## 444K Z-BAR / HIGH-LIFT / POWERLLEL

Fuel Tank (with ground-level fueling)	242 L (64 gal.)
Cooling System	19 L (20 qt.)
Engine Oil with Vertical Spin-On Filter	17.5 L (18.5 qt.)
Transmission Fluid with Vertical Filter	18.5 L (19.5 qt.)
Axle Oil (front and rear)	22 L (23 qt.)
Hydraulic Reservoir and Filters	91 L (24 gal.)
Park Brake Oil (wet disc)	0.3 L (10 oz.)

## Hydraulic System/Steering

Pump (loader and steering)	variable-displacement, axial-piston pump; closed-center, pressure-compensating system	
Maximum Rated Flow @ 6895 kPa (1,000 psi) and 2,350 rpm	140 L/m (37 gpm)	
System Relief Pressure (loader and steering)	24 821 kPa (3,600 psi)	
Loader Controls	2-function valve, joystick control or fingertip controls, hydraulic-function enable/disable, optional 3rd- and 4th-function valve with auxiliary lever	
Steering (conforms to ISO 5010)	Typepower, fully hydraulic	
Articulation Angle	80-deg. arc (40 deg. each direction)	
Hydraulic Cycle Times	<b>Z-Bar</b>	<b>High-Lift</b>
Raise	5.9 sec.	5.9 sec.
Dump	1.0 sec.	1.0 sec.
Lower (float down)	2.4 sec.	2.4 sec.
Total	9.3 sec.	9.3 sec.
Turning Radius (measured to centerline of outside tire)	4.74 m (15 ft. 7 in.)	

## Powerllel

5.9 sec.
1.1 sec.
1.9 sec.
8.9 sec.

## Dimensions with Standard Configuration

	<b>Z-Bar</b> 1.9-m <sup>3</sup> (2.5 cu. yd.) pin-on bucket	<b>High-Lift</b> 1.9-m <sup>3</sup> (2.5 cu. yd.) pin-on bucket	<b>Powerllel</b> 1.9-m <sup>3</sup> (2.5 cu. yd.) hook-on bucket with coupler
<b>A</b> Height to Top of Cab and Canopy	3.17 m (10 ft. 5 in.)	3.17 m (10 ft. 5 in.)	3.17 m (10 ft. 5 in.)
<b>B</b> Ground Clearance	393 mm (15.5 in.)	393 mm (15.5 in.)	393 mm (15.5 in.)
<b>C</b> Length from Centerline to Front Axle	1.37 m (4 ft. 6 in.)	1.37 m (4 ft. 6 in.)	1.37 m (4 ft. 6 in.)
<b>D</b> Wheelbase	2.76 m (9 ft. 1 in.)	2.76 m (9 ft. 1 in.)	2.76 m (9 ft. 1 in.)
<b>E</b> Dump Clearance	▲ (see page 19)	▲ (see page 19)	▲ (see page 20)
<b>F</b> Height to Hinge Pin, Fully Raised	3.60 m (11 ft. 10 in.)	4.00 m (13 ft. 1 in.)	3.67 m (12 ft. 0 in.)
<b>G</b> Dump Reach	▲▲ (see page 19)	▲▲ (see page 19)	▲▲ (see page 20)
<b>H</b> Maximum Digging Depth	105 mm (4.1 in.)	105 mm (4.1 in.)	119 mm (4.7 in.)
<b>I</b> Overall Length	▲▲▲ (see page 19)	▲▲▲ (see page 19)	▲▲▲ (see page 20)
<b>J</b> Maximum Rollback at Ground Level	41 deg.	41 deg.	42 deg.
<b>K</b> Maximum Rollback, Boom Fully Raised	55 deg.	55 deg.	51 deg.
<b>L</b> Maximum Bucket Angle, Fully Raised	50 deg.	50 deg.	50 deg.

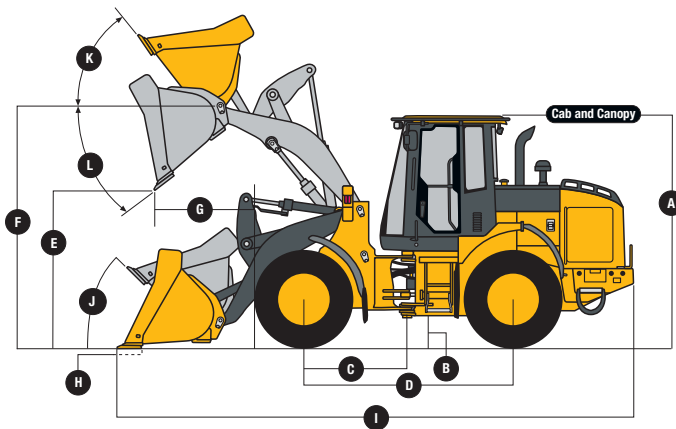

444K Z-BAR AND HIGH-LIFT LOADERS

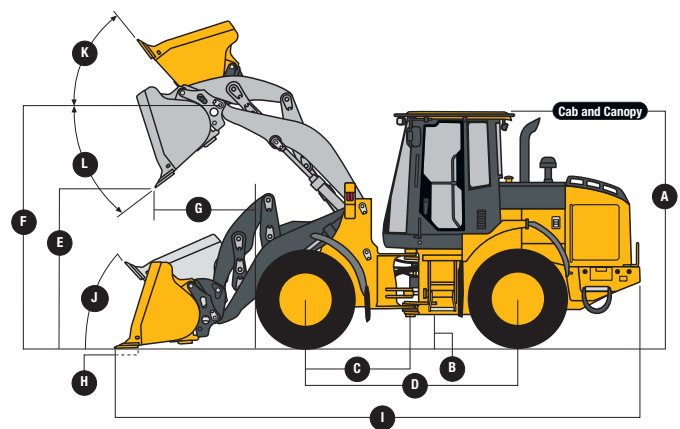

444K POWERLLEL LOADER

**Dimensions with Quick-Coupler and Hook-On Bucket**

**444K Z-BAR / HIGH-LIFT / POWERLLEL**

	Z-Bar	High-Lift	Powerllel
A Dump Clearance	▲ (see page 19)	▲ (see page 20)	▲ (see page 20)
B Dump Reach	▲▲ (see page 19)	▲▲ (see page 20)	▲▲ (see page 20)
C Maximum Digging Depth	139 mm (5.5 in.)	148 mm (5.8 in.)	119 mm (4.7 in.)
D Height to Hinge Pin, Fully Raised	3.60 m (11 ft. 10 in.)	3.98 m (13 ft. 1 in.)	3.67 m (12 ft. 0 in.)
E Overall Length	▲▲▲ (see page 19)	▲▲▲ (see page 20)	▲▲▲ (see page 20)
F Maximum Rollback, Boom Fully Raised	55 deg.	49 deg.	51 deg.
G Maximum Bucket Angle, Fully Raised	42 deg.	45 deg.	50 deg.
H Maximum Rollback at Ground Level	42 deg.	39 deg.	42 deg.

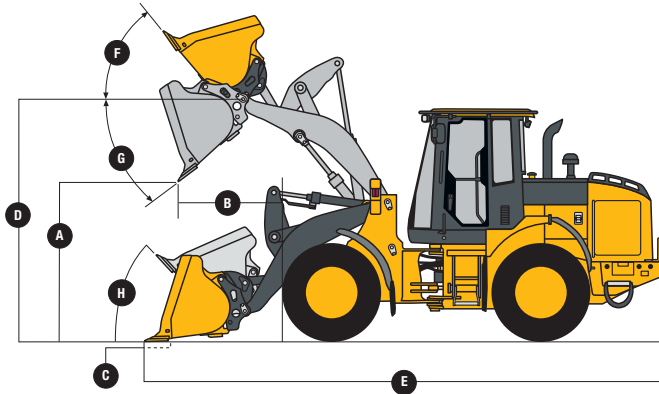

**444K Z-BAR AND HIGH-LIFT LOADERS WITH QUICK-COUPLER AND HOOK-ON BUCKET**

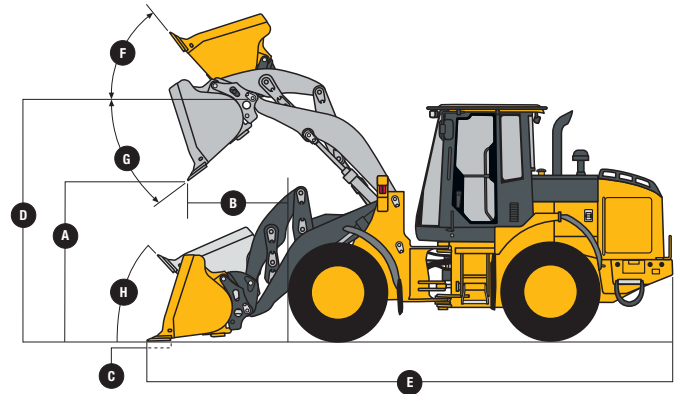

**444K POWERLLEL LOADER WITH QUICK-COUPLER AND HOOK-ON BUCKET**

**Dimensions with Quick-Coupler and Hook-On Construction Fork**

	Z-Bar	High-Lift	Powerllel
A Reach, Fully Raised	0.86 m (34 in.)	0.86 m (34 in.)	0.86 m (34 in.)
B Fork Height, Fully Raised	3.44 m (11 ft. 3 in.)	3.79 m (12 ft. 5 in.)	3.51 m (11 ft. 6 in.)
C Maximum Reach, Fork Level	1.57 m (5 ft. 2 in.)	1.84 m (6 ft. 0 in.)	1.63 m (5 ft. 4 in.)
D Maximum Reach, Fork Height	1.69 m (5 ft. 6 in.)	1.70 m (5 ft. 7 in.)	1.73 m (5 ft. 8 in.)
E Reach, Ground Level	0.97 m (3 ft. 2 in.)	1.31 m (4 ft. 4 in.)	0.96 m (3 ft. 2 in.)
F Depth Below Ground	35.6 mm (1.4 in.)	35.6 mm (1.4 in.)	2 mm (0.1 in.)
G Tine Length	▲ (see page 20)	▲ (see page 20)	▲ (see page 20)
H Overall Length	▲▲ (see page 20)	▲▲ (see page 20)	▲▲ (see page 20)

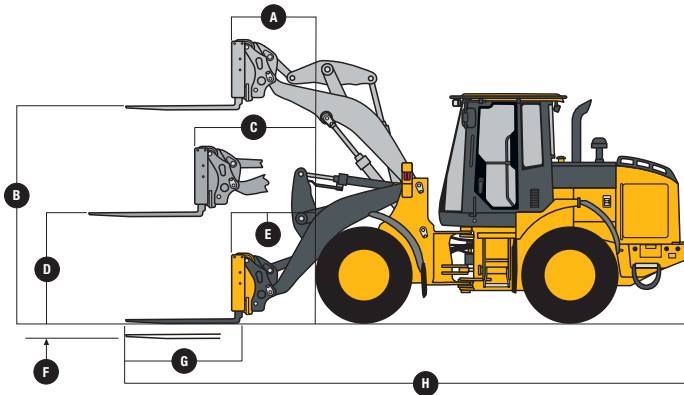

**444K Z-BAR AND HIGH-LIFT LOADERS WITH QUICK-COUPLER AND HOOK-ON CONSTRUCTION FORK**

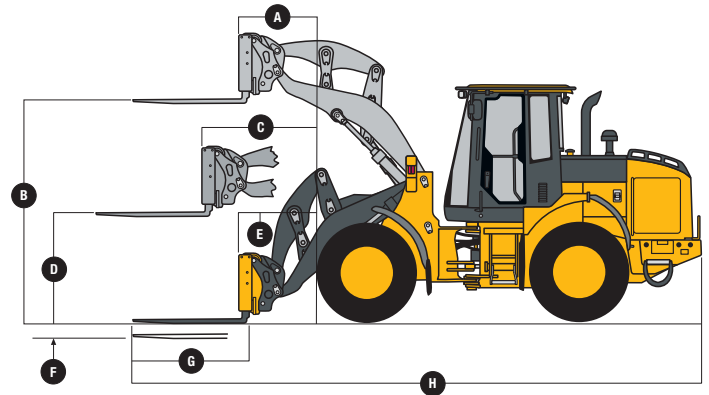

**444K POWERLLEL LOADER WITH QUICK-COUPLER AND HOOK-ON CONSTRUCTION FORK**

#### 444K Z-Bar with Pin-On-Type Bucket

Bucket Type/Size	<i>General-Purpose with Bolt-On Edge</i>	
Capacity, Heaped . . . . .	1.9 m <sup>3</sup> (2.5 cu. yd.)	
Capacity, Struck . . . . .	1.6 m <sup>3</sup> (2.1 cu. yd.)	
Bucket Weight . . . . .	870 kg (1,919 lb.)	
Bucket Width . . . . .	2.54 m (8 ft. 4 in.)	
Breakout Force . . . . .	8023 kg (17,688 lb.)	
Tipping Load, Straight . . . . .	9275 kg (20,447 lb.)	
Tipping Load, 40-Deg. Full Turn . . . . .	8072 kg (17,796 lb.)	
Reach, 45-Deg. Dump, 2.13-m (7 ft.)		
Clearance . . . . .	1.44 m (4 ft. 9 in.)	
▲▲ Reach, 45-Deg. Dump, Full Height . . . . .	1.04 m (3 ft. 5 in.)	
▲ Dump Clearance, 45 Deg., Full Height . . . . .	2.67 m (8 ft. 9 in.)	
▲▲▲ Overall Length, Bucket on Ground . . . . .	6.86 m (22 ft. 6 in.)	
Loader Clearance Circle, Bucket Carry		
Position . . . . .	11.07 m (36 ft. 4 in.)	
Operating Weight . . . . .	11 055 kg (24,372 lb.)	

*Loader operating information is based on machine with identified linkage and standard equipment, ROPS cab, rear cast bumper/counterweight, transmission side-frame guards, bottom guards, standard tires, full fuel tank, and 79-kg (175 lb.) operator. This information is affected by changes in tires, ballast, and different attachments, and assumes no tire deflection per the standard ISO 14397-1 section 5.*

#### 444K High-Lift with Pin-On-Type Bucket

Bucket Type/Size	<i>General-Purpose with Bolt-On Edge</i>	
Capacity, Heaped . . . . .	1.9 m <sup>3</sup> (2.5 cu. yd.)	
Capacity, Struck . . . . .	1.6 m <sup>3</sup> (2.1 cu. yd.)	
Bucket Weight . . . . .	870 kg (1,919 lb.)	
Bucket Width . . . . .	2.54 m (8 ft. 4 in.)	
Breakout Force . . . . .	7412 kg (16,341 lb.)	
Tipping Load, Straight . . . . .	7889 kg (17,392 lb.)	
Tipping Load, 40-Deg. Full Turn . . . . .	6845 kg (15,091 lb.)	
Reach, 45-Deg. Dump, 2.13-m (7 ft.)		
Clearance . . . . .	1.78 m (5 ft. 10 in.)	
▲▲ Reach, 45-Deg. Dump, Full Height . . . . .	1.04 m (3 ft. 5 in.)	
▲ Dump Clearance, 45 Deg., Full Height . . . . .	3.03 m (9 ft. 11 in.)	
▲▲▲ Overall Length, Bucket on Ground . . . . .	7.38 m (24 ft. 3 in.)	
Loader Clearance Circle, Bucket Carry		
Position . . . . .	11.39 m (37 ft. 5 in.)	
Operating Weight . . . . .	11 168 kg (24,621 lb.)	

*Loader operating information is based on machine with identified linkage and standard equipment, ROPS cab, rear cast bumper/counterweight, transmission side-frame guards, bottom guards, standard tires, full fuel tank, and 79-kg (175 lb.) operator. This information is affected by changes in tires, ballast, and different attachments, and assumes no tire deflection per the standard ISO 14397-1 section 5.*

#### 444K Z-Bar with Quick-Coupler and Hook-On-Type Bucket

Bucket Type/Size	<i>General-Purpose with Bolt-On Edge</i>	
Capacity, Heaped . . . . .	1.9 m <sup>3</sup> (2.5 cu. yd.)	1.5 m <sup>3</sup> (2.0 cu. yd.)
Capacity, Struck . . . . .	1.6 m <sup>3</sup> (2.1 cu. yd.)	1.2 m <sup>3</sup> (1.6 cu. yd.)
Bucket Weight with Coupler . . . . .	1250 kg (2,756 lb.)	1177 kg (2,594 lb.)
Bucket Width . . . . .	2.54 m (8 ft. 4 in.)	2.54 m (8 ft. 4 in.)
Breakout Force . . . . .	6725 kg (14,826 lb.)	7151 kg (15,765 lb.)
Tipping Load, Straight . . . . .	8360 kg (18,431 lb.)	8523 kg (18,790 lb.)
Tipping Load, 40-Deg. Full Turn . . . . .	7229 kg (15,936 lb.)	7381 kg (16,272 lb.)
Reach, 45-Deg. Dump, 2.13-m (7 ft.)		
Clearance . . . . .	1.47 m (4 ft. 10 in.)	1.44 m (4 ft. 9 in.)
▲▲ Reach, 45-Deg. Dump, Full Height . . . . .	1.15 m (3 ft. 9 in.)	1.07 m (3 ft. 6 in.)
▲ Dump Clearance, 45 Deg., Full Height . . . . .	2.54 m (8 ft. 4 in.)	2.62 m (8 ft. 7 in.)
▲▲▲ Overall Length, Bucket on Ground . . . . .	7.05 m (23 ft. 1 in.)	6.93 m (22 ft. 9 in.)
Loader Clearance Circle, Bucket Carry		
Position . . . . .	11.19 m (34 ft. 9 in.)	11.13 m (36 ft. 6 in.)
Operating Weight . . . . .	11 434 kg (25,208 lb.)	11 361 kg (25,047 lb.)

*Loader operating information is based on machine with identified linkage and standard equipment, ROPS cab, rear cast bumper/counterweight, transmission side-frame guards, bottom guards, standard tires, full fuel tank, and 79-kg (175 lb.) operator. This information is affected by changes in tires, ballast, and different attachments, and assumes no tire deflection per the standard ISO 14397-1 section 5.*

#### 444K High-Lift with Quick-Coupler and Hook-On-Type Bucket

Bucket Type/Size	General-Purpose with Bolt-On Edge	
Capacity, Heaped	1.9 m <sup>3</sup> (2.5 cu. yd.)	1.5 m <sup>3</sup> (2.0 cu. yd.)
Capacity, Struck	1.6 m <sup>3</sup> (2.1 cu. yd.)	1.2 m <sup>3</sup> (1.6 cu. yd.)
Bucket Weight with Coupler	1250 kg (2,756 lb.)	1177 kg (2,594 lb.)
Bucket Width	2.54 m (8 ft. 4 in.)	2.54 m (8 ft. 4 in.)
Breakout Force	6200 kg (13,669 lb.)	6577 kg (14,500 lb.)
Tipping Load, Straight	7092 kg (15,635 lb.)	7249 kg (15,980 lb.)
Tipping Load, 40-Deg. Full Turn	6105 kg (13,459 lb.)	6251 kg (13,782 lb.)
Reach, 45-Deg. Dump, 2.13-m (7 ft.)		
Clearance	1.78 m (5 ft. 10 in.)	1.75 m (5 ft. 9 in.)
▲▲ Reach, 45-Deg. Dump, Full Height	1.15 m (3 ft. 9 in.)	1.07 m (3 ft. 6 in.)
▲ Dump Clearance, 45 Deg., Full Height	2.90 m (9 ft. 6 in.)	2.98 m (9 ft. 9 in.)
▲▲▲ Overall Length, Bucket on Ground	7.38 m (24 ft. 3 in.)	7.26 m (23 ft. 10 in.)
Loader Clearance Circle, Bucket Carry		
Position	11.47 m (37 ft. 7 in.)	11.39 m (37 ft. 4 in.)
Operating Weight	11 548 kg (25,459 lb.)	11 475 kg (25,298 lb.)

Loader operating information is based on machine with identified linkage and standard equipment, ROPS cab, rear cast bumper/counterweight, transmission side-frame guards, bottom guards, standard tires, full fuel tank, and 79-kg (175 lb.) operator. This information is affected by changes in tires, ballast, and different attachments, and assumes no tire deflection per the standard ISO 14397-1 section 5.

#### 444K Powerllel with Quick-Coupler and Hook-On-Type Bucket

Bucket Type/Size	General-Purpose with Bolt-On Edge	
Capacity, Heaped	1.9 m <sup>3</sup> (2.5 cu. yd.)	1.5 m <sup>3</sup> (2.0 cu. yd.)
Capacity, Struck	1.6 m <sup>3</sup> (2.1 cu. yd.)	1.2 m <sup>3</sup> (1.6 cu. yd.)
Bucket Weight with Coupler	1262 kg (2,782 lb.)	1189 kg (2,621 lb.)
Bucket Width	2.54 m (8 ft. 4 in.)	2.54 m (8 ft. 4 in.)
Breakout Force	6056 kg (13,352 lb.)	6700 kg (14,770 lb.)
Tipping Load, Straight	7230 kg (15,940 lb.)	7416 kg (16,349 lb.)
Tipping Load, 40-Deg. Full Turn	6226 kg (13,726 lb.)	6398 kg (14,105 lb.)
Reach, 45-Deg. Dump, 2.13-m (7 ft.)		
Clearance	1.51 m (4 ft. 11 in.)	1.48 m (4 ft. 10 in.)
▲▲ Reach, 45-Deg. Dump, Full Height	1.14 m (3 ft. 9 in.)	1.06 m (3 ft. 6 in.)
▲ Dump Clearance, 45 Deg., Full Height	2.58 m (8 ft. 5 in.)	2.65 m (8 ft. 8 in.)
▲▲▲ Overall Length, Bucket on Ground	7.15 m (23 ft. 5 in.)	7.03 m (23 ft. 1 in.)
Loader Clearance Circle, Bucket Carry		
Position	11.23 m (36 ft. 10 in.)	11.15 m (36 ft. 7 in.)
Operating Weight	12 074 kg (26,619 lb.)	12 000 kg (26,455 lb.)

Loader operating information is based on machine with identified linkage and standard equipment, ROPS cab, rear cast bumper/counterweight, transmission side-frame guards, bottom guards, standard tires, full fuel tank, and 79-kg (175 lb.) operator. This information is affected by changes in tires, ballast, and different attachments, and assumes no tire deflection per the standard ISO 14397-1 section 5.

#### Specifications with Quick-Coupler and Hook-On Construction Fork

	Z-Bar		High-Lift		Powerllel	
▲ Tine Length	1.22 m (48 in.)	1.52 m (60 in.)	1.22 m (48 in.)	1.52 m (60 in.)	1.22 m (48 in.)	1.52 m (60 in.)
▲▲ Overall Length	7.45 m (24 ft. 5 in.)	7.77 m (25 ft. 6 in.)	7.79 m (25 ft. 7 in.)	8.09 m (26 ft. 6 in.)	7.52 m (24 ft. 8 in.)	7.82 m (25 ft. 8 in.)
Tipping Load, Straight (fork level, load centered and positioned at 50% tine length)	6210 kg (13,691 lb.)	5851 kg (12,899 lb.)	5575 kg (12,291 lb.)	5271 kg (11,621 lb.)	5814 kg (12,818 lb.)	5417 kg (11,943 lb.)
Tipping Load, 40-Deg. Full Turn (fork level, load centered and positioned at 50% tine length)	5394 kg (11,892 lb.)	5077 kg (11,193 lb.)	4829 kg (10,646 lb.)	4560 kg (10,053 lb.)	5038 kg (11,106 lb.)	4678 kg (10,314 lb.)
Operating Weight	11 163 kg (24,610 lb.)	11 206 kg (24,705 lb.)	11 277 kg (24,862 lb.)	11 320 kg (24,956 lb.)	11 803 kg (26,021 lb.)	11 950 kg (26,345 lb.)

Loader operating information is based on machine with identified linkage and standard equipment, ROPS cab, rear cast bumper/counterweight, transmission side-frame guards, bottom guards, standard tires, full fuel tank, and 79-kg (175 lb.) operator. This information is affected by changes in tires, ballast, and different attachments, and assumes no tire deflection per the standard ISO 14397-1 section 5.

#### Adjustments to Operating Weights and Tipping Loads with Buckets

Adjustments to operating weights and tipping loads are based on Z-bar machine and pin-on 1.9-m<sup>3</sup> (2.5 cu. yd.) general-purpose bucket with bolt-on cutting edge, ROPS cab, rear cast bumper/counterweight, transmission side-frame guards, bottom guards, standard tires, full fuel tank, and 79-kg (175 lb.) operator\*

Add (+) or deduct (-) lb. (kg) as indicated for loaders with 3-piece rims and	Operating Weight	Tipping Load, Straight	Tipping Load, 40-Deg. Full Turn, SAE
17.5 R 25, 1 Star L-3	0 kg (0 lb.)	0 kg (0 lb.)	0 kg (0 lb.)
17.5 R 25, 1 Star L-2	- 89 kg (- 196 lb.)	- 59 kg (- 130 lb.)	- 53 kg (- 117 lb.)
17.5-25, 12 PR L-3	- 193 kg (- 424 lb.)	- 101 kg (- 223 lb.)	- 116 kg (- 256 lb.)
17.5-25, L-2 <sup>†</sup>	- 164 kg (- 362 lb.)	- 75 kg (- 165 lb.)	- 175 kg (- 386 lb.)
17.5-25, L-2	- 165 kg (- 364 lb.)	- 76 kg (- 168 lb.)	- 51 kg (- 112 lb.)
20.5-25, 12 PR L-2 <sup>‡</sup>	+ 58 kg (+ 128 lb.)	+ 54 kg (+ 119 lb.)	+ 52 kg (+ 115 lb.)
20.5-25, 1 Star L-2 <sup>‡</sup>	+ 206 kg (+ 454 lb.)	+ 154 kg (+ 340 lb.)	+ 142 kg (+ 313 lb.)
550/65 R 25, 1 Star L-2 <sup>‡</sup>	+ 242 kg (+ 534 lb.)	+ 213 kg (+ 470 lb.)	+ 162 kg (+ 357 lb.)
Rear cast bumper/counterweight (removed)	- 104 kg (- 229 lb.)	- 241 kg (- 531 lb.)	- 202 kg (- 445 lb.)

\*May change based on vehicle configuration, weight, or tire-pressure adjustments.

<sup>†</sup>Equipped with one-piece rims.

<sup>‡</sup>CaCl<sub>2</sub> not recommended.

Bucket Selection Guides\*

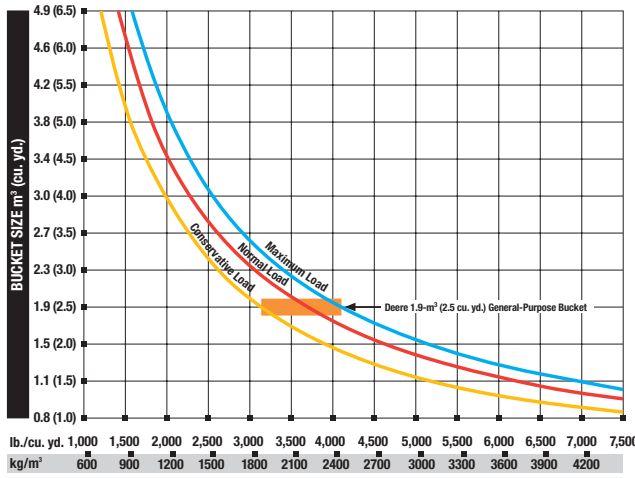

444K Z-BAR LOADER WITH PIN-ON BUCKET

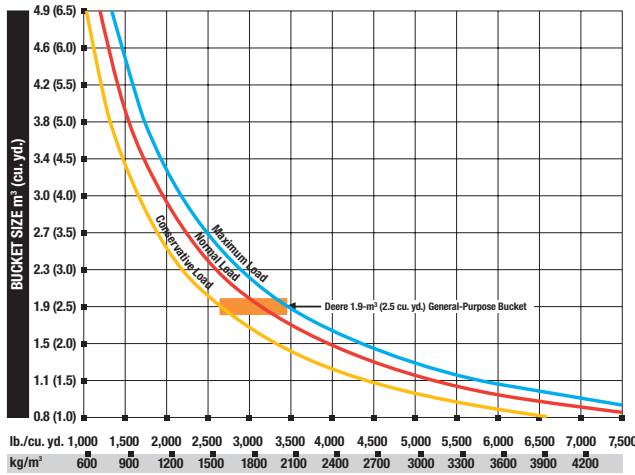

444K HIGH-LIFT LOADER WITH PIN-ON BUCKET

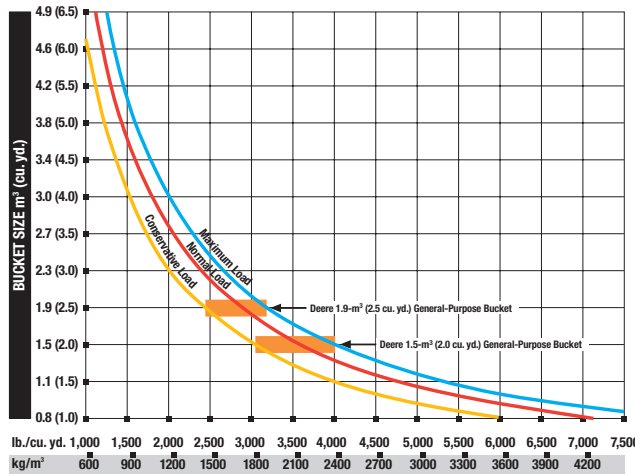

444K POWERLEL LOADER WITH QUICK-COUPLER AND HOOK-ON BUCKET

LOOSE MATERIALS		kg/m³	lb./cu. yd.
Chips, pulpwood		288	486
Cinders (coal, ashes, clinkers)		673	1,134
Clay and gravel, dry		1602	2,700
Clay, compact, solid		1746	2,943
Clay, dry in lump loose		1009	1,701
Clay, excavated in water		1282	2,160
Coal, anthracite, broken, loose		865	1,458
Coal, bituminous, moderately wet		801	1,350
Earth, common loam, dry		1218	2,052
Earth, mud, packed		1843	3,105
Granite, broken		1538	2,592
Gypsum		2275	3,834
Limestone, coarse, sized		1570	2,646
Limestone, mixed sizes		1682	2,835
Limestone, pulverized or crushed		1362	2,295
Sand, damp		2083	3,510
Sand, dry		1762	2,970
Sand, voids, full of water		2083	3,510
Sandstone, quarried		1314	2,214
Shale, broken crushed		1362	2,295
Slag, furnace granulated		1955	3,294
Stone or gravel, 37.5 to 87.5-mm (1.5 to 3.5") size		1442	2,430
Stone or gravel, 18.75-mm (3/4") size		1602	2,700

\* This guide, representing bucket sizes not necessarily manufactured by Deere, will help you in selecting proper bucket size for material density, loader configuration, and operating conditions. Optimum bucket size is determined after adding or subtracting all tipping load changes due to optional equipment. The "conservative load" line on this guide is recommended when operating in conditions such as soft ground and uneven surfaces. The "maximum load" condition on this guide is sometimes utilized when operating on firm ground and level surfaces.

LOOSE MATERIALS		kg/m³	lb./cu. yd.
Chips, pulpwood		288	486
Cinders (coal, ashes, clinkers)		673	1,134
Clay and gravel, dry		1602	2,700
Clay, compact, solid		1746	2,943
Clay, dry in lump loose		1009	1,701
Clay, excavated in water		1282	2,160
Coal, anthracite, broken, loose		865	1,458
Coal, bituminous, moderately wet		801	1,350
Earth, common loam, dry		1218	2,052
Earth, mud, packed		1843	3,105
Granite, broken		1538	2,592
Gypsum		2275	3,834
Limestone, coarse, sized		1570	2,646
Limestone, mixed sizes		1682	2,835
Limestone, pulverized or crushed		1362	2,295
Sand, damp		2083	3,510
Sand, dry		1762	2,970
Sand, voids, full of water		2083	3,510
Sandstone, quarried		1314	2,214
Shale, broken crushed		1362	2,295
Slag, furnace granulated		1955	3,294
Stone or gravel, 37.5 to 87.5-mm (1.5 to 3.5") size		1442	2,430
Stone or gravel, 18.75-mm (3/4") size		1602	2,700

\* This guide, representing bucket sizes not necessarily manufactured by Deere, will help you in selecting proper bucket size for material density, loader configuration, and operating conditions. Optimum bucket size is determined after adding or subtracting all tipping load changes due to optional equipment. The "conservative load" line on this guide is recommended when operating in conditions such as soft ground and uneven surfaces. The "maximum load" condition on this guide is sometimes utilized when operating on firm ground and level surfaces.

LOOSE MATERIALS		kg/m³	lb./cu. yd.
Chips, pulpwood		288	486
Cinders (coal, ashes, clinkers)		673	1,134
Clay and gravel, dry		1602	2,700
Clay, compact, solid		1746	2,943
Clay, dry in lump loose		1009	1,701
Clay, excavated in water		1282	2,160
Coal, anthracite, broken, loose		865	1,458
Coal, bituminous, moderately wet		801	1,350
Earth, common loam, dry		1218	2,052
Earth, mud, packed		1843	3,105
Granite, broken		1538	2,592
Gypsum		2275	3,834
Limestone, coarse, sized		1570	2,646
Limestone, mixed sizes		1682	2,835
Limestone, pulverized or crushed		1362	2,295
Sand, damp		2083	3,510
Sand, dry		1762	2,970
Sand, voids, full of water		2083	3,510
Sandstone, quarried		1314	2,214
Shale, broken crushed		1362	2,295
Slag, furnace granulated		1955	3,294
Stone or gravel, 37.5 to 87.5-mm (1.5 to 3.5") size		1442	2,430
Stone or gravel, 18.75-mm (3/4") size		1602	2,700

\* This guide, representing bucket sizes not necessarily manufactured by Deere, will help you in selecting proper bucket size for material density, loader configuration, and operating conditions. Optimum bucket size is determined after adding or subtracting all tipping load changes due to optional equipment. The "conservative load" line on this guide is recommended when operating in conditions such as soft ground and uneven surfaces. The "maximum load" condition on this guide is sometimes utilized when operating on firm ground and level surfaces.

# Specifications <sup>524K</sup>

## Engine

### 524K Z-BAR / HIGH-LIFT

Manufacturer and Model	John Deere PowerTech™ E 6068H
Non-Road Emissions Standard	EPA Tier 3/EU Stage IIIA
Cylinders	6
Valves Per Cylinder	2
Displacement	6.8 L (414 cu. in.)
Net Peak Power @ 2,000 rpm	110 kW (146 hp)
Net Peak Torque @ 1,600 rpm	607 Nm (448 lb.-ft.)
Net Torque Rise	47%
Fuel System (electronically controlled)	high-pressure common rail
Lubrication	full-flow spin-on filter and integral cooler
Aspiration	turbocharged, charge air cooled
Air Cleaner	under-hood, dual-element dry type, restriction indicator in cab monitor for service
Fan Drive	hydraulically driven, proportionally controlled, fan aft of coolers
Electrical System	24 volt with 80-amp alternator (100-amp alternator optional)
Batteries (2 – 12 volt)	950 CCA (each)

## Transmission

Type	countershaft-type PowerShift™	
Torque Converter	single stage, single phase	
Shift Control	electronically modulated, adaptive, load and speed dependent	
Operator Interface	steering-column or joystick-mounted F-N-R and gear-select lever; quick-shift button on hydraulic lever	
Shift Modes	manual/auto (1st-D or 2nd-D); quick-shift button with 2 selectable modes: kick-down or kick-up/down; and 3 adjustable clutch-cutoff settings	
Travel Speeds (with 20.5-25 tires)	<i>Forward Maximum</i>	<i>Reverse Maximum</i>
Gear 1	7.3 km/h (4.5 mph)	7.2 km/h (4.5 mph)
Gear 2	12.0 km/h (7.5 mph)	12.6 km/h (7.8 mph)
Gear 3	23.0 km/h (14.3 mph)	24.1 km/h (15.0 mph)
Gear 4	36.0 km/h (22.4 mph)	N/A

## Axles/Brakes

Final Drives	heavy-duty inboard-mounted planetary
Differentials	hydraulic locking front with conventional rear — standard; dual locking front and rear — optional
Rear Axle Oscillation, Stop to Stop (with 20.5-25 tires)	24 deg.
Brakes (conform to ISO 3450)	
Service Brakes	hydraulically actuated, inboard sun-shaft mounted, oil cooled, self adjusting, single disc
Parking Brake	automatic spring applied, hydraulically released, driveline mounted, oil cooled, multi disc

## Tires

Choice of (with 3-piece rims)*	Tread Width	Width Over Tires	Change In Vertical Height
20.5 R 25, 1 Star L-3	1950 mm (76.8 in.)	2545 mm (100.2 in.)	standard
20.5 R 25, 1 Star L-2	1950 mm (76.8 in.)	2541 mm (100.0 in.)	- 5 mm (- 0.2 in.)
20.5-25, 16 PR L-2	1950 mm (76.8 in.)	2545 mm (100.2 in.)	+ 3 mm (+ 0.1 in.)
20.5-25, 12 PR L-2	1950 mm (76.8 in.)	2545 mm (100.2 in.)	+ 3 mm (+ 0.1 in.)
20.5-25, 16 PR L-3	1950 mm (76.8 in.)	2545 mm (100.2 in.)	+ 9 mm (+ 0.4 in.)
600/65 R 25, 1 Star L-3T <sup>§</sup>	1950 mm (76.8 in.)	2633 mm (103.7 in.)	- 22 mm (- 0.9 in.)
23.1-26 Logger <sup>†</sup>	2136 mm (84.1 in.)	2743 mm (108.0 in.)	+ 80 mm (+ 3.1 in.)

\*Based on Z-bar machine configuration; may change based on vehicle configuration, weight, or tire-pressure adjustments.

<sup>§</sup>CaCl<sub>2</sub> not recommended.

<sup>†</sup>Equipped with one-piece rims.

## Refill Capacities (U.S.)

## 524K Z-BAR / HIGH-LIFT

Fuel Tank (with ground-level fueling)	325 L (86 gal.)
Cooling System	23 L (24 qt.)
Engine Oil with Vertical Spin-On Filter	19 L (20 qt.)
Transmission Fluid with Vertical Filter	18.5 L (19.5 qt.)
Axle Oil (front and rear)	17 L (18 qt.)
Hydraulic Reservoir and Filters	91 L (24 gal.)
Park Brake Oil (wet disc)	0.3 L (10 oz.)

## Hydraulic System/Steering

Pump (loader and steering)	variable-displacement, axial-piston pump; closed-center, pressure-compensating system
Maximum Rated Flow @ 6895 kPa (1,000 psi) and 2,350 rpm	165 L/m (44 gpm)
System Relief Pressure (loader and steering)	24 994 kPa (3,625 psi)
Loader Controls	2-function valve, joystick control or fingertip controls, hydraulic-function enable/disable, optional 3rd- and 4th-function valve with auxiliary lever
Steering (conforms to ISO 5010)	
Typepower, fully hydraulic	
Articulation Angle	80-deg. arc (40 deg. each direction)
Hydraulic Cycle Times	<b>Z-Bar</b>
Raise	6.1 sec.
Dump	1.4 sec.
Lower (float down)	3.0 sec.
Total	10.5 sec.
Turning Radius (measured to centerline of outside tire)	5.00 m (16 ft. 5 in.)

### High-Lift

Raise	6.1 sec.
Dump	1.4 sec.
Lower (float down)	3.0 sec.
Total	10.5 sec.

## Dimensions with Standard Configuration

	<b>Z-Bar</b> 2.1-m <sup>3</sup> (2.75 cu. yd.) pin-on bucket	<b>High-Lift</b> 2.3-m <sup>3</sup> (3.0 cu. yd.) pin-on bucket
<b>A</b> Height to Top of Cab and Canopy	3.25 m (10 ft. 8 in.)	3.25 m (10 ft. 8 in.)
<b>B</b> Ground Clearance	0.40 m (15.7 in.)	0.40 m (15.7 in.)
<b>C</b> Length from Centerline to Front Axle	1.45 m (4 ft. 9 in.)	1.45 m (4 ft. 9 in.)
<b>D</b> Wheelbase	2.93 m (9 ft. 7 in.)	2.93 m (9 ft. 7 in.)
<b>E</b> Dump Clearance	▲ (see page 25)	▲ (see page 25)
<b>F</b> Height to Hinge Pin, Fully Raised	3.77 m (12 ft. 5 in.)	4.12 m (13 ft. 6 in.)
<b>G</b> Dump Reach	▲▲ (see page 25)	▲▲ (see page 25)
<b>H</b> Maximum Digging Depth	97 mm (3.80 in.)	222 mm (8.7 in.)
<b>I</b> Overall Length	▲▲▲ (see page 25)	▲▲▲ (see page 25)
<b>J</b> Maximum Rollback at Ground Level	41 deg.	41 deg.
<b>K</b> Maximum Rollback, Boom Fully Raised	55 deg.	50 deg.
<b>L</b> Maximum Bucket Angle, Fully Raised	51 deg.	47 deg.

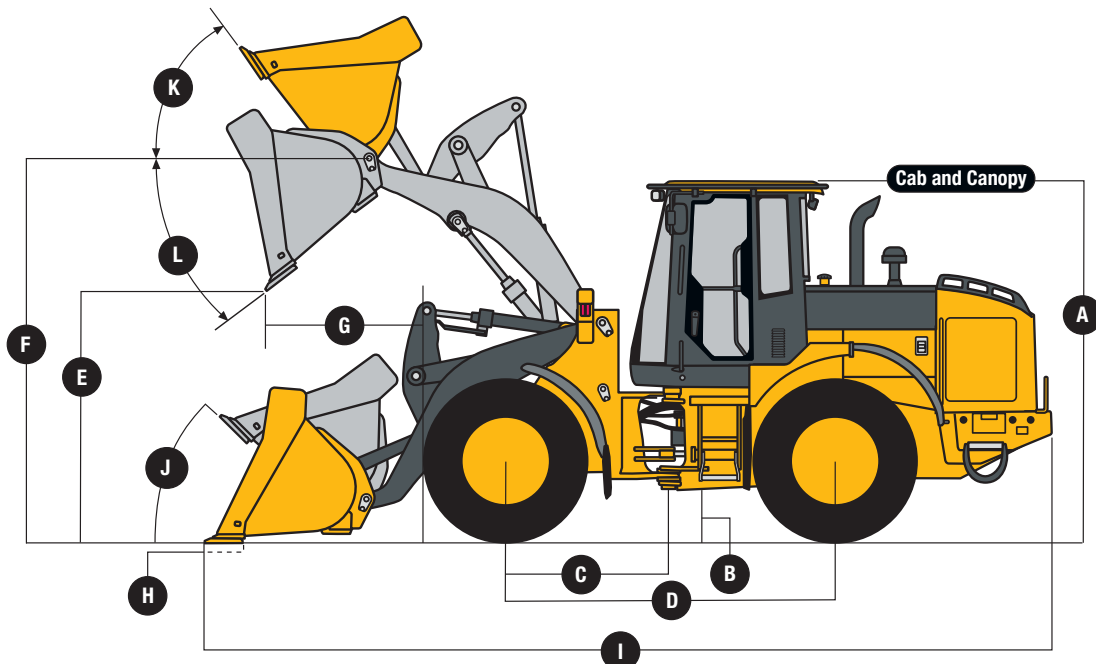

524K Z-BAR AND HIGH-LIFT LOADERS

**Dimensions with Quick-Coupler and Hook-On Bucket**

**524K Z-BAR / HIGH-LIFT**

	Z-Bar	High-Lift
<b>A</b> Dump Clearance	▲ (see page 25)	▲ (see page 26)
<b>B</b> Dump Reach	▲▲ (see page 25)	▲▲ (see page 26)
<b>C</b> Maximum Digging Depth	146 mm (5.7 in.)	226 mm (10.3 in.)
<b>D</b> Height to Hinge Pin, Fully Raised	3.77 m (12 ft. 5 in.)	4.12 m (13 ft. 6 in.)
<b>E</b> Overall Length	▲▲▲ (see page 25)	▲▲▲ (see page 26)
<b>F</b> Maximum Rollback, Boom Fully Raised	54 deg.	48 deg.
<b>G</b> Maximum Bucket Angle, Fully Raised	48 deg.	48 deg.
<b>H</b> Maximum Rollback at Ground Level	40 deg.	45 deg.

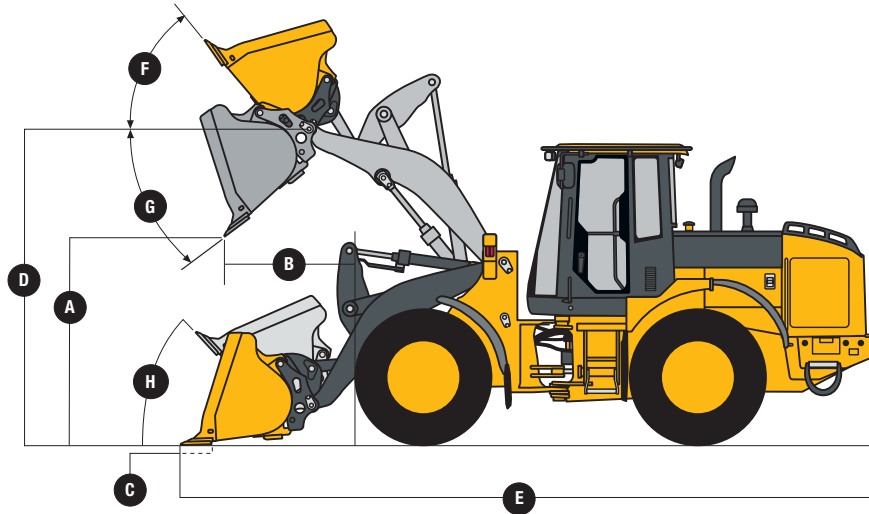

**524K Z-BAR AND HIGH-LIFT LOADERS WITH QUICK-COUPLER AND HOOK-ON BUCKET**

**Dimensions with Quick-Coupler and Hook-On Construction Fork**

	Z-Bar	High-Lift
<b>A</b> Reach, Fully Raised	0.80 m (31.3 in.)	0.81 m (31.9 in.)
<b>B</b> Fork Height, Fully Raised	3.55 m (11 ft. 8 in.)	3.90 m (12 ft. 9 in.)
<b>C</b> Maximum Reach, Fork Level	1.54 m (5 ft. 1 in.)	1.80 m (5 ft. 11 in.)
<b>D</b> Maximum Reach, Fork Height	1.72 m (5 ft. 8 in.)	1.72 m (5 ft. 8 in.)
<b>E</b> Reach, Ground Level	0.94 m (3 ft. 1 in.)	1.27 m (4 ft. 2 in.)
<b>F</b> Depth Below Ground	16 mm (0.6 in.)	95 mm (3.7 in.)
<b>G</b> Tine Length	▲ (see page 26)	▲ (see page 26)
<b>H</b> Overall Length	▲▲ (see page 26)	▲▲ (see page 26)

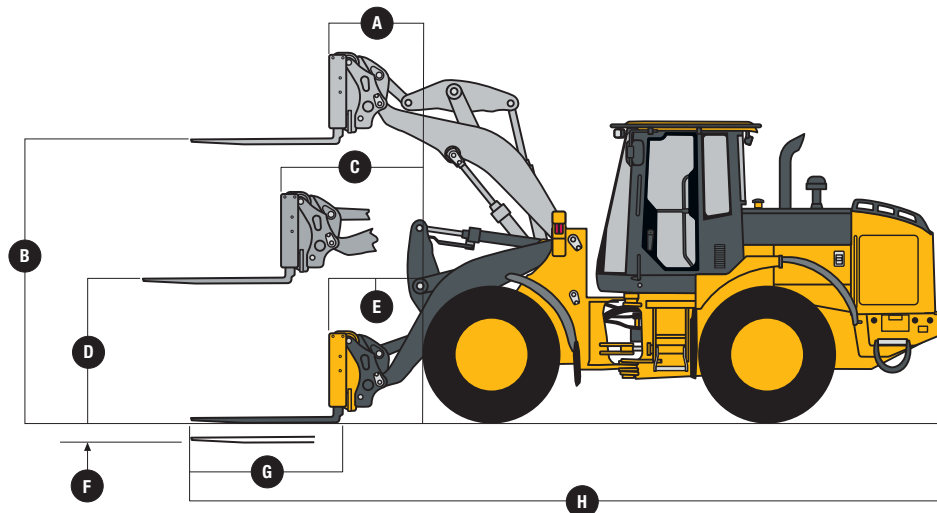

**524K Z-BAR AND HIGH-LIFT LOADERS WITH QUICK-COUPLER AND HOOK-ON CONSTRUCTION FORK**



## 524K Z-Bar with Pin-On-Type Bucket

Bucket Type/Size	General-Purpose with Bolt-On Edge	
Capacity, Heaped	2.1 m <sup>3</sup> (2.75 cu. yd.)	
Capacity, Struck	1.7 m <sup>3</sup> (2.27 cu. yd.)	
Bucket Weight	991 kg (2,185 lb.)	
Bucket Width	2.54 m (8 ft. 4 in.)	
Breakout Force	9193 kg (20,267 lb.)	
Tipping Load, Straight	10 288 kg (22,682 lb.)	
Tipping Load, 40-Deg. Full Turn	8935 kg (19,698 lb.)	
Reach, 45-Deg. Dump, 2.13-m (7 ft.)		
Clearance	1.44 m (4 ft. 9 in.)	
▲▲ Reach, 45-Deg. Dump, Full Height	0.98 m (3 ft. 2 in.)	
▲ Dump Clearance, 45 Deg., Full Height	2.77 m (9 ft. 1 in.)	
▲▲▲ Overall Length, Bucket on Ground	7.34 m (24 ft. 1 in.)	
Loader Clearance Circle, Bucket Carry		
Position	11.60 m (38 ft. 1 in.)	
Operating Weight	12 282 kg (27,077 lb.)	

Loader operating information is based on machine with identified linkage and standard equipment, ROPS cab, rear cast bumper/counterweight, transmission side-frame guards, bottom guards, standard tires, full fuel tank, and 79-kg (175 lb.) operator. This information is affected by changes in tires, ballast, and different attachments, and assumes no tire deflection per the standard ISO 14397-1 section 5.

## 524K High-Lift with Pin-On-Type Bucket

Bucket Type/Size	General-Purpose with Bolt-On Edge	
Capacity, Heaped	2.1 m <sup>3</sup> (2.75 cu. yd.)	
Capacity, Struck	1.7 m <sup>3</sup> (2.27 cu. yd.)	
Bucket Weight	991 kg (2,185 lb.)	
Bucket Width	2.54 m (8 ft. 4 in.)	
Breakout Force	8504 kg (22,394 lb.)	
Tipping Load, Straight	8750 kg (19,290 lb.)	
Tipping Load, 40-Deg. Full Turn	7572 kg (16,693 lb.)	
Reach, 45-Deg. Dump, 2.13-m (7 ft.)		
Clearance	1.73 m (5 ft. 8 in.)	
▲▲ Reach, 45-Deg. Dump, Full Height	0.99 m (3 ft. 3 in.)	
▲ Dump Clearance, 45 Deg., Full Height	3.12 m (10 ft. 3 in.)	
▲▲▲ Overall Length, Bucket on Ground	7.67 m (25 ft. 2 in.)	
Loader Clearance Circle, Bucket Carry		
Position	11.90 m (39 ft. 1 in.)	
Operating Weight	12 474 kg (27,500 lb.)	

Loader operating information is based on machine with identified linkage and standard equipment, ROPS cab, rear cast bumper/counterweight, transmission side-frame guards, bottom guards, standard tires, full fuel tank, and 79-kg (175 lb.) operator. This information is affected by changes in tires, ballast, and different attachments, and assumes no tire deflection per the standard ISO 14397-1 section 5.

## 524K Z-Bar with Quick-Coupler and Hook-On-Type Bucket

Bucket Type/Size	General-Purpose with Bolt-On Edge	
Capacity, Heaped	2.1 m <sup>3</sup> (2.75 cu. yd.)	1.9 m <sup>3</sup> (2.5 cu. yd.)
Capacity, Struck	1.7 m <sup>3</sup> (2.27 cu. yd.)	1.6 m <sup>3</sup> (2.1 cu. yd.)
Bucket Weight with Coupler	1369 kg (3,018 lb.)	1294 kg (2,853 lb.)
Bucket Width	2.54 m (8 ft. 4 in.)	2.54 m (8 ft. 4 in.)
Breakout Force	7567 kg (16,682 lb.)	8182 kg (18,038 lb.)
Tipping Load, Straight	9074 kg (20,005 lb.)	9221 kg (20,328 lb.)
Tipping Load, 40-Deg. Full Turn	7831 kg (17,264 lb.)	7968 kg (17,567 lb.)
Reach, 45-Deg. Dump, 2.13-m (7 ft.)		
Clearance	1.47 m (4 ft. 10 in.)	1.44 m (4 ft. 9 in.)
▲▲ Reach, 45-Deg. Dump, Full Height	1.10 m (3 ft. 7 in.)	1.03 m (3 ft. 5 in.)
▲ Dump Clearance, 45 Deg., Full Height	2.61 m (8 ft. 7 in.)	2.67 m (8 ft. 9 in.)
▲▲▲ Overall Length, Bucket on Ground	7.57 m (24 ft. 10 in.)	7.48 m (24 ft. 6 in.)
Loader Clearance Circle, Bucket Carry		
Position	11.77 m (38 ft. 7 in.)	11.72 m (38 ft. 6 in.)
Operating Weight	12 660 kg (27,911 lb.)	12 585 kg (27,745 lb.)

Loader operating information is based on machine with identified linkage and standard equipment, ROPS cab, rear cast bumper/counterweight, transmission side-frame guards, bottom guards, standard tires, full fuel tank, and 79-kg (175 lb.) operator. This information is affected by changes in tires, ballast, and different attachments, and assumes no tire deflection per the standard ISO 14397-1 section 5.

## 524K High-Lift with Quick-Coupler and Hook-On-Type Bucket

Bucket Type/Size	General-Purpose with Bolt-On Edge	
Capacity, Heaped	2.1 m <sup>3</sup> (2.75 cu. yd.)	1.9 m <sup>3</sup> (2.5 cu. yd.)
Capacity, Struck	1.7 m <sup>3</sup> (2.27 cu. yd.)	1.6 m <sup>3</sup> (2.1 cu. yd.)
Bucket Weight with Coupler	1377 kg (3,037 lb.)	1302 kg (2,871 lb.)
Bucket Width	2.54 m (8 ft. 4 in.)	2.54 m (8 ft. 4 in.)
Breakout Force	6984 kg (15,397 lb.)	7552 kg (16,649 lb.)
Tipping Load, Straight	7720 kg (17,020 lb.)	7859 kg (17,326 lb.)
Tipping Load, 40-Deg. Full Turn	6629 kg (14,614 lb.)	6760 kg (14,903 lb.)
Reach, 45-Deg. Dump, 2.13-m (7 ft.)		
Clearance	1.77 m (5 ft. 10 in.)	1.74 m (5 ft. 8 in.)
▲▲ Reach, 45-Deg. Dump, Full Height	1.11 m (3 ft. 8 in.)	1.05 m (3 ft. 5 in.)
▲ Dump Clearance, 45 Deg., Full Height	2.96 m (9 ft. 8 in.)	3.02 m (9 ft. 11 in.)
▲▲▲ Overall Length, Bucket on Ground	7.90 m (25 ft. 11 in.)	7.80 m (25 ft. 7 in.)
Loader Clearance Circle, Bucket Carry		
Position	12.08 m (39 ft. 8 in.)	12.01 m (39 ft. 5 in.)
Operating Weight	12 861 kg (28,354 lb.)	12 786 kg (28,188 lb.)

Loader operating information is based on machine with identified linkage and standard equipment, ROPS cab, rear cast bumper/counterweight, transmission side-frame guards, bottom guards, standard tires, full fuel tank, and 79-kg (175 lb.) operator. This information is affected by changes in tires, ballast, and different attachments, and assumes no tire deflection per the standard ISO 14397-1 section 5.

## Specifications with Quick-Coupler and Hook-On Construction Fork

	Z-Bar		High-Lift	
▲ Tine Length	1.22 m (48 in.)	1.52 m (60 in.)	1.22 m (48 in.)	1.52 m (60 in.)
▲▲ Overall Length	7.88 m (25 ft. 10 in.)	8.18 m (26 ft. 10 in.)	8.21 m (26 ft. 11 in.)	8.51 m (27 ft. 11 in.)
Tipping Load, Straight (fork level, load centered and positioned at 50% tine length)	7121 kg (15,698 lb.)	6718 kg (14,811 lb.)	6386 kg (14,078 lb.)	6044 kg (13,325 lb.)
Tipping Load, 40-Deg. Full Turn (fork level, load centered and positioned at 50% tine length)	6180 kg (13,625 lb.)	5825 kg (12,842 lb.)	5524 kg (12,179 lb.)	5223 kg (11,515 lb.)
Operating Weight	12 314 kg (27,148 lb.)	12 357 kg (27,243 lb.)	12 515 kg (27,591 lb.)	12 558 kg (27,686 lb.)

Loader operating information is based on machine with identified linkage and standard equipment, ROPS cab, rear cast bumper/counterweight, transmission side-frame guards, bottom guards, standard tires, full fuel tank, and 79-kg (175 lb.) operator. This information is affected by changes in tires, ballast, and different attachments, and assumes no tire deflection per the standard ISO 14397-1 section 5.

## Adjustments to Operating Weights and Tipping Loads with Buckets

Adjustments to operating weights and tipping loads are based on Z-bar machine and pin-on 2.1-m<sup>3</sup> (2.75 cu. yd.) general-purpose bucket with bolt-on cutting edge, ROPS cab, rear cast bumper/counterweight, transmission side-frame guards, bottom guards, standard tires, full fuel tank, and 79-kg (175 lb.) operator\*

Add (+) or deduct (-) lb. (kg) as indicated for	Operating Weight	Tipping Load, Straight	Tipping Load, 40-Deg. Full Turn, SAE
loaders with 3-piece rims and			
20.5 R 25, 1 Star L-3	0 kg (0 lb.)	0 kg (0 lb.)	0 kg (0 lb.)
20.5 R 25, 1 Star L-2	- 148 kg (- 326 lb.)	- 108 kg (- 238 lb.)	- 95 kg (- 210 lb.)
20.5-25, 16 PR L-2	- 324 kg (- 714 lb.)	- 236 kg (- 521 lb.)	- 209 kg (- 460 lb.)
20.5-25, 12 PR L-2	- 297 kg (- 655 lb.)	- 217 kg (- 478 lb.)	- 191 kg (- 421 lb.)
20.5-25, 16 PR L-3	- 228 kg (- 502 lb.)	- 166 kg (- 367 lb.)	- 147 kg (- 324 lb.)
600/65 R 25, 1 Star L-3T <sup>§</sup>	+ 28 kg (+ 62 lb.)	+ 20 kg (+ 45 lb.)	+ 18 kg (+ 40 lb.)
23.1-26 Logger <sup>†</sup>	- 27 kg (- 59 lb.)	- 20 kg (- 43 lb.)	- 17 kg (- 38 lb.)
CaCl <sub>2</sub> in 20.5-25, L-3 rear tires	+ 824 kg (+ 1,817 lb.)	+ 1203 kg (+ 2,651 lb.)	+ 1061 kg (+ 2,338 lb.)
Rear cast bumper/counterweight (removed)	- 104 kg (- 229 lb.)	- 253 kg (- 558 lb.)	- 211 kg (- 465 lb.)

\*May change based on vehicle configuration, weight, or tire-pressure adjustments.

<sup>§</sup>CaCl<sub>2</sub> not recommended.

<sup>†</sup>Equipped with one-piece rims.

## Bucket Selection Guides\*

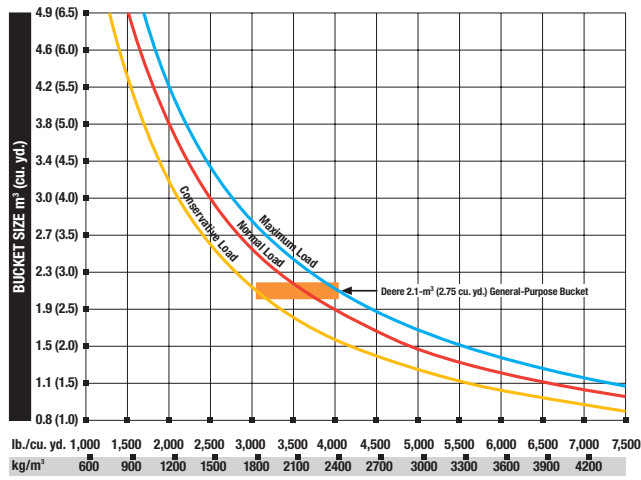

524K Z-BAR LOADER WITH PIN-ON BUCKET

LOOSE MATERIALS	kg/m <sup>3</sup>	lb./cu. yd.
Chips, pulpwood	288	486
Cinders (coal, ashes, clinkers)	673	1,134
Clay and gravel, dry	1602	2,700
Clay, compact, solid	1746	2,943
Clay, dry in lump loose	1009	1,701
Clay, excavated in water	1282	2,160
Coal, anthracite, broken, loose	865	1,458
Coal, bituminous, moderately wet	801	1,350
Earth, common loam, dry	1218	2,052
Earth, mud, packed	1843	3,105
Granite, broken	1538	2,592
Gypsum	2275	3,834
Limestone, coarse, sized	1570	2,646
Limestone, mixed sizes	1682	2,835
Limestone, pulverized or crushed	1362	2,295
Sand, damp	2083	3,510
Sand, dry	1782	2,970
Sand, voids, full of water	2083	3,510
Sandstone, quarried	1314	2,214
Shale, broken crushed	1362	2,295
Slag, furnace granulated	1955	3,294
Stone or gravel, 37.5 to 87.5-mm (1.5 to 3.5") size	1442	2,430
Stone or gravel, 18.75-mm (3/4") size	1602	2,700

\* This guide, representing bucket sizes not necessarily manufactured by Deere, will help you in selecting proper bucket size for material density, loader configuration, and operating conditions. Optimum bucket size is determined after adding or subtracting all tipping load changes due to optional equipment. The "conservative load" line on this guide is recommended when operating in conditions such as soft ground and uneven surfaces. The "maximum load" condition on this guide is sometimes utilized when operating on firm ground and level surfaces.

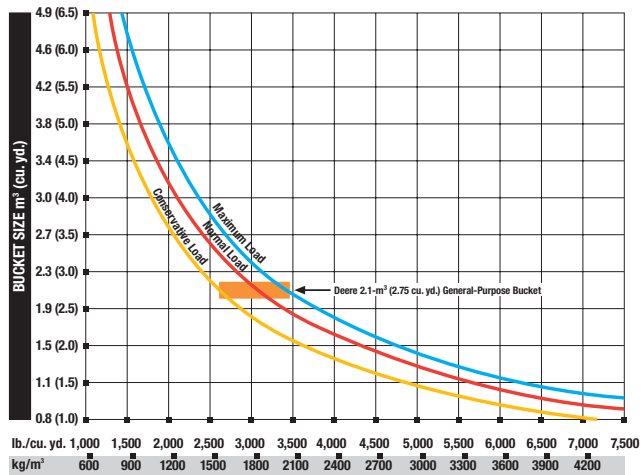

524K HIGH-LIFT LOADER WITH PIN-ON BUCKET

LOOSE MATERIALS	kg/m <sup>3</sup>	lb./cu. yd.
Chips, pulpwood	288	486
Cinders (coal, ashes, clinkers)	673	1,134
Clay and gravel, dry	1602	2,700
Clay, compact, solid	1746	2,943
Clay, dry in lump loose	1009	1,701
Clay, excavated in water	1282	2,160
Coal, anthracite, broken, loose	865	1,458
Coal, bituminous, moderately wet	801	1,350
Earth, common loam, dry	1218	2,052
Earth, mud, packed	1843	3,105
Granite, broken	1538	2,592
Gypsum	2275	3,834
Limestone, coarse, sized	1570	2,646
Limestone, mixed sizes	1682	2,835
Limestone, pulverized or crushed	1362	2,295
Sand, damp	2083	3,510
Sand, dry	1782	2,970
Sand, voids, full of water	2083	3,510
Sandstone, quarried	1314	2,214
Shale, broken crushed	1362	2,295
Slag, furnace granulated	1955	3,294
Stone or gravel, 37.5 to 87.5-mm (1.5 to 3.5") size	1442	2,430
Stone or gravel, 18.75-mm (3/4") size	1602	2,700

\* This guide, representing bucket sizes not necessarily manufactured by Deere, will help you in selecting proper bucket size for material density, loader configuration, and operating conditions. Optimum bucket size is determined after adding or subtracting all tipping load changes due to optional equipment. The "conservative load" line on this guide is recommended when operating in conditions such as soft ground and uneven surfaces. The "maximum load" condition on this guide is sometimes utilized when operating on firm ground and level surfaces.

# Specifications



Engine	544K Z-BAR / HIGH-LIFT / POWERLLEL™
Manufacturer and Model	John Deere PowerTech™ E 6068H
Non-Road Emissions Standard	EPA Tier 3/EU Stage IIIA
Cylinders	6
Valves Per Cylinder	2
Displacement	6.8 L (414 cu. in.)
Net Peak Power @ 1,900 rpm	125 kW (167 hp)
Net Peak Torque @ 1,600 rpm	673 Nm (496 lb.-ft.)
Net Torque Rise	38%
Fuel System (electronically controlled)	high-pressure common rail
Lubrication	full-flow spin-on filter and integral cooler
Aspiration	turbocharged, charge air cooled
Air Cleaner	under-hood, dual-element dry type, restriction indicator in cab monitor for service
Fan Drive	hydraulically driven, proportionally controlled, fan aft of coolers
Electrical System	24 volt with 80-amp alternator (100-amp alternator optional)
Batteries (2 – 12 volt)	950 CCA (each)

Transmission		
Type	countershaft-type PowerShift™	
Torque Converter	single stage, single phase	
Shift Control	electronically modulated, adaptive, load and speed dependent	
Operator Interface	steering-column or joystick-mounted F-N-R and gear-select lever; quick-shift button on hydraulic lever	
Shift Modes	manual/auto (1st-D or 2nd-D); quick-shift button with 2 selectable modes: kick-down or kick-up/down; and 3 adjustable clutch-cutoff settings	
Travel Speeds (with 20.5 R 25 tires)	<i>Forward Maximum</i>	<i>Reverse Maximum</i>
Gear 1	7.2 km/h (4.5 mph)	7.2 km/h (4.5 mph)
Gear 2	11.9 km/h (7.4 mph)	12.6 km/h (7.8 mph)
Gear 3	22.8 km/h (14.2 mph)	24.1 km/h (15.0 mph)
Gear 4	35.7 km/h (22.2 mph)	N/A

Axles/Brakes	
Final Drives	heavy-duty inboard-mounted planetary
Differentials	hydraulic locking front with conventional rear — standard; dual locking front and rear — optional
Rear Axle Oscillation, Stop to Stop (with 20.5 R 25 tires)	24 deg.
Brakes (conform to ISO 3450)	
Service Brakes	hydraulically actuated, inboard sun-shaft mounted, oil cooled, self adjusting, single disc
Parking Brake	automatic spring applied, hydraulically released, driveline mounted, oil cooled, multi disc

Tires	Tread Width	Width Over Tires	Change In Vertical Height
Choice of (with 3-piece rims)*			standard
20.5 R 25, 1 Star L-3	1950 mm (76.8 in.)	2546 mm (100.2 in.)	– 5 mm (– 0.2 in.)
20.5 R 25, 1 Star L-2	1950 mm (76.8 in.)	2541 mm (100.0 in.)	+ 3 mm (+ 0.1 in.)
20.5-25, 16 PR L-2	1950 mm (76.8 in.)	2544 mm (100.2 in.)	+ 3 mm (+ 0.1 in.)
20.5-25, 12 PR L-2	1950 mm (76.8 in.)	2544 mm (100.2 in.)	+ 9 mm (+ 0.4 in.)
20.5-25, 16 PR L-3	1950 mm (76.8 in.)	2544 mm (100.2 in.)	– 22 mm (– 0.9 in.)
600/65 R 25, 1 Star L-3T <sup>§</sup>	1950 mm (76.8 in.)	2633 mm (103.7 in.)	+ 80 mm (+ 3.1 in.)
23.1-26 Logger <sup>†</sup>	2136 mm (84.1 in.)	2743 mm (108.0 in.)	

\*Based on Z-bar machine configuration; may change based on vehicle configuration, weight, or tire-pressure adjustments.

<sup>§</sup>CaCl<sub>2</sub> not recommended.

<sup>†</sup>Equipped with one-piece rims.

## Refill Capacities (U.S.)

## 544K Z-BAR / HIGH-LIFT / POWERLLEL

Fuel Tank (with ground-level fueling)	325 L (86 gal.)
Cooling System	23 L (24 qt.)
Engine Oil with Vertical Spin-On Filter	19 L (20 qt.)
Transmission Fluid with Vertical Filter	18.5 L (19.5 qt.)
Axle Oil (front and rear)	17 L (18 qt.)
Hydraulic Reservoir and Filters	91 L (24 gal.)
Park Brake Oil (wet disc)	0.3 L (10 oz.)

## Hydraulic System/Steering

Pump (loader and steering)	variable-displacement, axial-piston pump; closed-center, pressure-compensating system		
Maximum Rated Flow @ 6895 kPa (1,000 psi) and 2,350 rpm	189 L/m (50 gpm)		
System Relief Pressure (loader and steering)	25 166 kPa (3,650 psi)		
Loader Controls	2-function valve, joystick control or fingertip controls, hydraulic-function enable/disable, optional 3rd- and 4th-function valve with auxiliary lever		
Steering (conforms to ISO 5010)	Typepower, fully hydraulic		
Articulation Angle	80-deg. arc (40 deg. each direction)		
Hydraulic Cycle Times	<b>Z-Bar</b>	<b>High-Lift</b>	<b>Powerllel</b>
Raise	5.8 sec.	5.8 sec.	5.8 sec.
Dump	1.2 sec.	1.2 sec.	1.2 sec.
Lower (float down)	3.2 sec.	3.2 sec.	2.5 sec.
Total	10.2 sec.	10.2 sec.	9.5 sec.
Turning Radius (measured to centerline of outside tire)	5.00 m (16 ft. 5 in.)		

## Dimensions with Standard Configuration

	<b>Z-Bar</b> 2.3-m <sup>3</sup> (3.0 cu. yd.) pin-on bucket	<b>High-Lift</b> 2.3-m <sup>3</sup> (3.0 cu. yd.) pin-on bucket	<b>Powerllel</b> 2.3-m <sup>3</sup> (3.0 cu. yd.) hook-on bucket with coupler
<b>A</b> Height to Top of Cab and Canopy	3.24 m (10 ft. 8 in.)	3.24 m (10 ft. 8 in.)	3.24 m (10 ft. 8 in.)
<b>B</b> Ground Clearance	0.40 m (15.7 in.)	0.40 m (15.7 in.)	0.40 m (15.7 in.)
<b>C</b> Length from Centerline to Front Axle	1.45 m (4 ft. 9 in.)	1.45 m (4 ft. 9 in.)	1.45 m (4 ft. 9 in.)
<b>D</b> Wheelbase	2.93 m (9 ft. 7 in.)	2.93 m (9 ft. 7 in.)	2.93 m (9 ft. 7 in.)
<b>E</b> Dump Clearance	▲ (see page 31)	▲ (see page 31)	▲ (see page 32)
<b>F</b> Height to Hinge Pin, Fully Raised	3.82 m (12 ft. 6 in.)	4.17 m (13 ft. 8 in.)	3.85 m (12 ft. 8 in.)
<b>G</b> Dump Reach	▲▲ (see page 31)	▲▲ (see page 31)	▲▲ (see page 32)
<b>H</b> Maximum Digging Depth	95 mm (3.72 in.)	221 mm (8.7 in.)	127 mm (5.0 in.)
<b>I</b> Overall Length	▲▲▲ (see page 31)	▲▲▲ (see page 31)	▲▲▲ (see page 32)
<b>J</b> Maximum Rollback at Ground Level	42 deg.	41 deg.	42 deg.
<b>K</b> Maximum Rollback, Boom Fully Raised	55 deg.	50 deg.	51 deg.
<b>L</b> Maximum Bucket Angle, Fully Raised	49 deg.	46 deg.	50 deg.

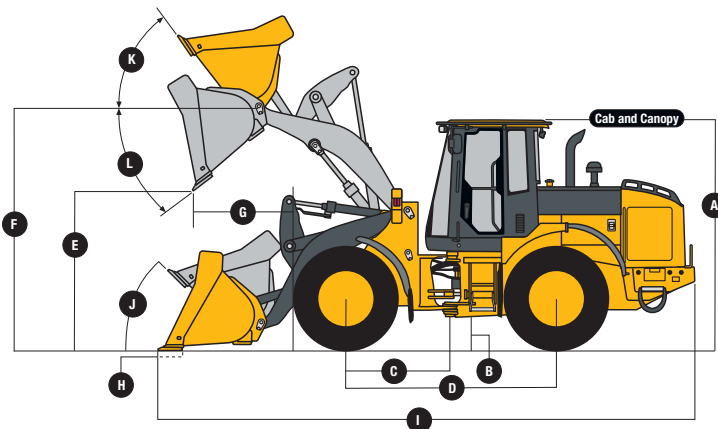

544K Z-BAR AND HIGH-LIFT LOADERS

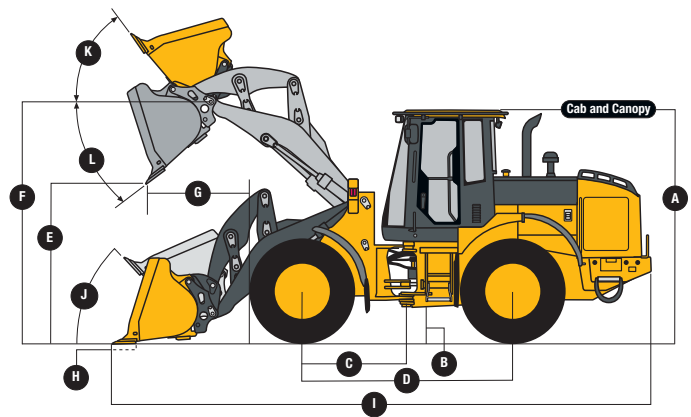

544K POWERLLEL LOADER

**Dimensions with Quick-Coupler and Hook-On Bucket**

**544K Z-BAR / HIGH-LIFT / POWERLLEL**

	Z-Bar	High-Lift	Powerllel
<b>A</b> Dump Clearance	▲ (see page 31)	▲ (see page 32)	▲ (see page 32)
<b>B</b> Dump Reach	▲▲ (see page 31)	▲▲ (see page 32)	▲▲ (see page 32)
<b>C</b> Maximum Digging Depth	138 mm (5.4 in.)	227 mm (8.9 in.)	127 mm (5.0 in.)
<b>D</b> Height to Hinge Pin, Fully Raised	3.81 m (12 ft. 6 in.)	4.13 m (13 ft. 7 in.)	3.85 m (12 ft. 8 in.)
<b>E</b> Overall Length	▲▲▲ (see page 31)	▲▲▲ (see page 32)	▲▲▲ (see page 32)
<b>F</b> Maximum Rollback, Boom Fully Raised	54 deg.	48 deg.	51 deg.
<b>G</b> Maximum Bucket Angle, Fully Raised	51 deg.	47 deg.	50 deg.
<b>H</b> Maximum Rollback at Ground Level	41 deg.	41 deg.	42 deg.

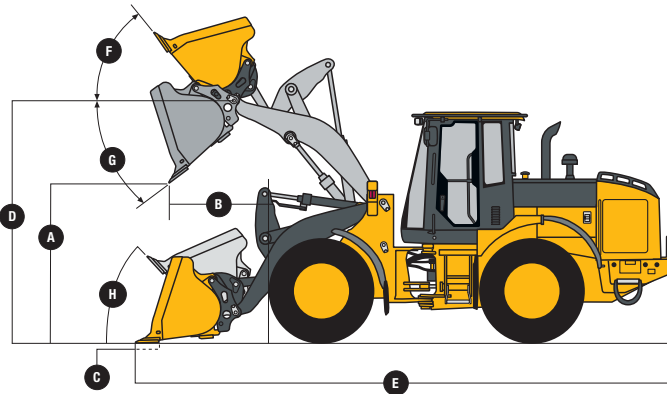

**544K Z-BAR AND HIGH-LIFT LOADERS WITH QUICK-COUPLER AND HOOK-ON BUCKET**

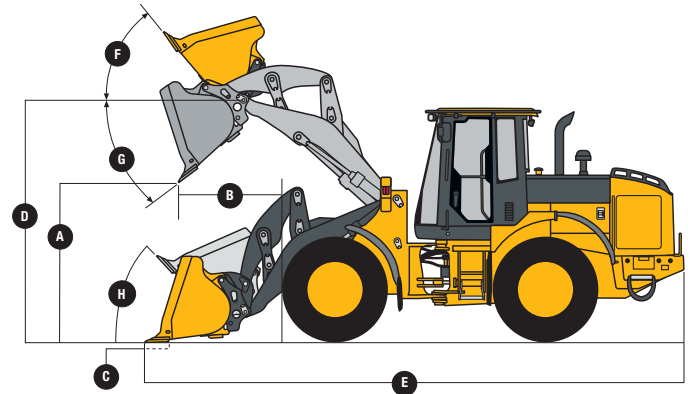

**544K POWERLLEL LOADER WITH QUICK-COUPLER AND HOOK-ON BUCKET**

**Dimensions with Quick-Coupler and Hook-On Construction Fork**

	Z-Bar	High-Lift	Powerllel
<b>A</b> Reach, Fully Raised	0.75 m (29.5 in.)	0.75 m (29.5 in.)	0.79 m (31 in.)
<b>B</b> Fork Height, Fully Raised	3.59 m (11 ft. 9 in.)	3.94 m (12 ft. 11 in.)	3.64 m (11 ft. 11 in.)
<b>C</b> Maximum Reach, Fork Level	1.54 m (5 ft. 1 in.)	1.80 m (5 ft. 11 in.)	1.61 m (5 ft. 4 in.)
<b>D</b> Maximum Reach, Fork Height	1.72 m (5 ft. 8 in.)	1.72 m (5 ft. 8 in.)	1.75 m (5 ft. 9 in.)
<b>E</b> Reach, Ground Level	0.95 m (3 ft. 2 in.)	1.28 m (4 ft. 3 in.)	0.99 m (3 ft. 3 in.)
<b>F</b> Depth Below Ground	13 mm (0.5 in.)	96 mm (3.8 in.)	1 mm (0.04 in.)
<b>G</b> Tine Length	▲ (see page 32)	▲ (see page 32)	▲ (see page 32)
<b>H</b> Overall Length	▲▲ (see page 32)	▲▲ (see page 32)	▲▲ (see page 32)

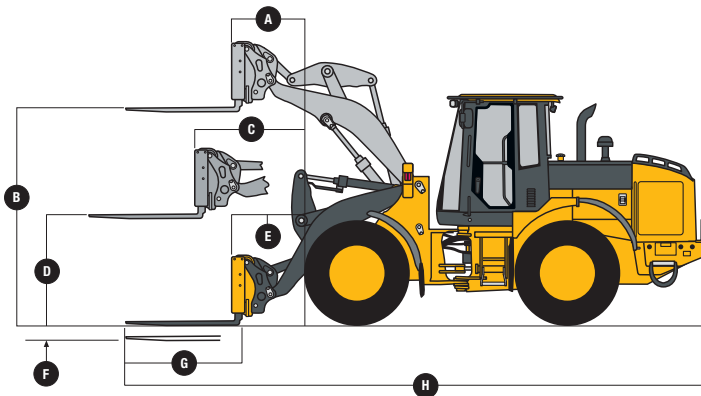

**544K Z-BAR AND HIGH-LIFT LOADERS WITH QUICK-COUPLER AND HOOK-ON CONSTRUCTION FORK**

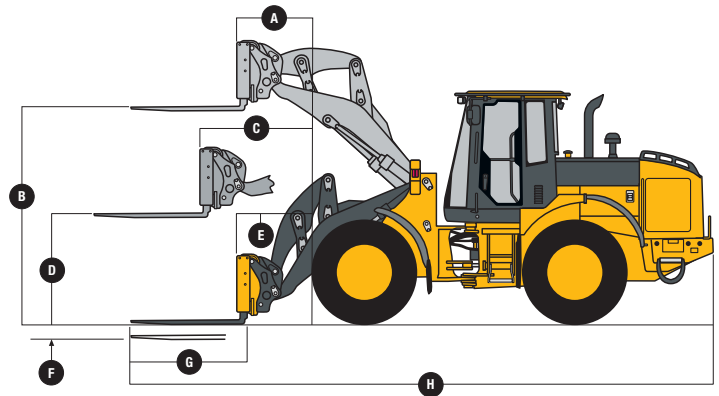

**544K POWERLLEL LOADER WITH QUICK-COUPLER AND HOOK-ON CONSTRUCTION FORK**

### 544K Z-Bar with Pin-On-Type Bucket

Bucket Type/Size	General-Purpose with Bolt-On Edge	
	Narrow	Wide
Capacity, Heaped	2.3 m <sup>3</sup> (3.0 cu. yd.)	2.3 m <sup>3</sup> (3.0 cu. yd.)
Capacity, Struck	2.0 m <sup>3</sup> (2.6 cu. yd.)	2.0 m <sup>3</sup> (2.6 cu. yd.)
Bucket Weight	1046 kg (2,305 lb.)	1028 kg (2,267 lb.)
Bucket Width	2.54 m (8 ft. 4 in.)	2.69 m (8 ft. 10 in.)
Breakout Force	10 188 kg (22,461 lb.)	11 000 kg (24,251 lb.)
Tipping Load, Straight	10 896 kg (24,021 lb.)	10 977 kg (24,201 lb.)
Tipping Load, 40-Deg. Full Turn	9434 kg (20,799 lb.)	9508 kg (20,961 lb.)
Reach, 45-Deg. Dump, 2.13-m (7 ft.)		
Clearance	1.46 m (4 ft. 10 in.)	1.44 m (4 ft. 9 in.)
▲▲ Reach, 45-Deg. Dump, Full Height	0.99 m (3 ft. 3 in.)	0.93 m (3 ft. 1 in.)
▲ Dump Clearance, 45 Deg., Full Height	2.76 m (9 ft. 1 in.)	2.82 m (9 ft. 3 in.)
▲▲▲ Overall Length, Bucket on Ground	7.43 m (24 ft. 4 in.)	7.34 m (24 ft. 1 in.)
Loader Clearance Circle, Bucket Carry		
Position	11.65 m (38 ft. 3 in.)	11.72 m (38 ft. 5 in.)
Operating Weight	12 820 kg (28,263 lb.)	12 802 kg (28,224 lb.)

Loader operating information is based on machine with identified linkage and standard equipment, ROPS cab, rear cast bumper/counterweight, transmission side-frame guards, bottom guards, standard tires, full fuel tank, and 79-kg (175 lb.) operator. This information is affected by changes in tires, ballast, and different attachments, and assumes no tire deflection per the standard ISO 14397-1 section 5.

### 544K High-Lift with Pin-On-Type Bucket

Bucket Type/Size	General-Purpose with Bolt-On Edge	
	Narrow	Wide
Capacity, Heaped	2.3 m <sup>3</sup> (3.0 cu. yd.)	2.3 m <sup>3</sup> (3.0 cu. yd.)
Capacity, Struck	2.0 m <sup>3</sup> (2.6 cu. yd.)	2.0 m <sup>3</sup> (2.6 cu. yd.)
Bucket Weight	1046 kg (2,305 lb.)	1029 kg (2,267 lb.)
Bucket Width	2.54 m (8 ft. 4 in.)	2.69 m (8 ft. 10 in.)
Breakout Force	9424 kg (20,776 lb.)	10 158 kg (22,395 lb.)
Tipping Load, Straight	9290 kg (20,480 lb.)	9345 kg (20,602 lb.)
Tipping Load, 40-Deg. Full Turn	8018 kg (17,678 lb.)	8069 kg (17,789 lb.)
Reach, 45-Deg. Dump, 2.13-m (7 ft.)		
Clearance	1.76 m (5 ft. 9 in.)	1.73 m (5 ft. 8 in.)
▲▲ Reach, 45-Deg. Dump, Full Height	0.99 m (3 ft. 3 in.)	0.93 m (3 ft. 1 in.)
▲ Dump Clearance, 45 Deg., Full Height	3.11 m (10 ft. 3 in.)	3.17 m (10 ft. 5 in.)
▲▲▲ Overall Length, Bucket on Ground	7.75 m (25 ft. 5 in.)	7.67 m (25 ft. 2 in.)
Loader Clearance Circle, Bucket Carry		
Position	11.96 m (39 ft. 3 in.)	12.03 m (39 ft. 6 in.)
Operating Weight	12 911 kg (28,464 lb.)	12 894 kg (28,426 lb.)

Loader operating information is based on machine with identified linkage and standard equipment, ROPS cab, rear cast bumper/counterweight, transmission side-frame guards, bottom guards, standard tires, full fuel tank, and 79-kg (175 lb.) operator. This information is affected by changes in tires, ballast, and different attachments, and assumes no tire deflection per the standard ISO 14397-1 section 5.

### 544K Z-Bar with Quick-Coupler and Hook-On-Type Bucket

Bucket Type/Size	General-Purpose with Bolt-On Edge	
	Narrow	Wide
Capacity, Heaped	2.3 m <sup>3</sup> (3.0 cu. yd.)	1.9 m <sup>3</sup> (2.5 cu. yd.)
Capacity, Struck	2.0 m <sup>3</sup> (2.6 cu. yd.)	1.6 m <sup>3</sup> (2.1 cu. yd.)
Bucket Weight with Coupler	1397 kg (3,080 lb.)	1294 kg (2,853 lb.)
Bucket Width	2.69 m (8 ft. 10 in.)	2.54 m (8 ft. 4 in.)
Breakout Force	9062 kg (19,978 lb.)	9809 kg (21,625 lb.)
Tipping Load, Straight	9720 kg (21,429 lb.)	12 385 kg (21,850 lb.)
Tipping Load, 40-Deg. Full Turn	8369 kg (18,451 lb.)	11 023 kg (18,847 lb.)
Reach, 45-Deg. Dump, 2.13-m (7 ft.)		
Clearance	1.46 m (4 ft. 10 in.)	1.44 m (4 ft. 9 in.)
▲▲ Reach, 45-Deg. Dump, Full Height	1.05 m (3 ft. 5 in.)	0.99 m (3 ft. 3 in.)
▲ Dump Clearance, 45 Deg., Full Height	2.66 m (8 ft. 9 in.)	2.72 m (8 ft. 11 in.)
▲▲▲ Overall Length, Bucket on Ground	7.57 m (24 ft. 10 in.)	7.48 m (24 ft. 6 in.)
Loader Clearance Circle, Bucket Carry		
Position	11.88 m (39 ft. 0 in.)	11.67 m (38 ft. 4 in.)
Operating Weight	13 171 kg (29,037 lb.)	13 068 kg (28,810 lb.)

Loader operating information is based on machine with identified linkage and standard equipment, ROPS cab, rear cast bumper/counterweight, transmission side-frame guards, bottom guards, standard tires, full fuel tank, and 79-kg (175 lb.) operator. This information is affected by changes in tires, ballast, and different attachments, and assumes no tire deflection per the standard ISO 14397-1 section 5.

### 544K High-Lift with Quick-Coupler and Hook-On-Type Bucket

Bucket Type/Size	General-Purpose with Bolt-On Edge	
Capacity, Heaped	2.3 m <sup>3</sup> (3.0 cu. yd.)	1.9 m <sup>3</sup> (2.5 cu. yd.)
Capacity, Struck	2.0 m <sup>3</sup> (2.6 cu. yd.)	1.6 m <sup>3</sup> (2.1 cu. yd.)
Bucket Weight with Coupler	1406 kg (3,099 lb.)	1303 kg (2,872 lb.)
Bucket Width	2.69 m (8 ft. 10 in.)	2.54 m (8 ft. 4 in.)
Breakout Force	8367 kg (18,446 lb.)	9055 kg (19,963 lb.)
Tipping Load, Straight	8295 kg (18,286 lb.)	8482 kg (18,699 lb.)
Tipping Load, 40-Deg. Full Turn	7110 kg (15,676 lb.)	7287 kg (16,065 lb.)
Reach, 45-Deg. Dump, 2.13-m (7 ft.)		
Clearance	1.77 m (5 ft. 10 in.)	1.77 m (5 ft. 10 in.)
▲▲ Reach, 45-Deg. Dump, Full Height	1.05 m (3 ft. 5 in.)	0.99 m (3 ft. 3 in.)
▲ Dump Clearance, 45 Deg., Full Height	3.01 m (9 ft. 10 in.)	3.07 m (10 ft. 1 in.)
▲▲▲ Overall Length, Bucket on Ground	7.90 m (25 ft. 11 in.)	7.80 m (25 ft. 7 in.)
Loader Clearance Circle, Bucket Carry		
Position	12.19 m (40 ft. 0 in.)	12.00 m (39 ft. 5 in.)
Operating Weight	13 271 kg (29,258 lb.)	13 168 kg (29,030 lb.)

Loader operating information is based on machine with identified linkage and standard equipment, ROPS cab, rear cast bumper/counterweight, transmission side-frame guards, bottom guards, standard tires, full fuel tank, and 79-kg (175 lb.) operator. This information is affected by changes in tires, ballast, and different attachments, and assumes no tire deflection per the standard ISO 14397-1 section 5.

### 544K Powerllel with Quick-Coupler and Hook-On-Type Bucket

Bucket Type/Size	General-Purpose with Bolt-On Edge	
Capacity, Heaped	2.3 m <sup>3</sup> (3.0 cu. yd.)	1.9 m <sup>3</sup> (2.5 cu. yd.)
Capacity, Struck	2.0 m <sup>3</sup> (2.6 cu. yd.)	1.6 m <sup>3</sup> (2.1 cu. yd.)
Bucket Weight with Coupler	1384 kg (3,051 lb.)	1281 kg (2,824 lb.)
Bucket Width	2.69 m (8 ft. 10 in.)	2.54 m (8 ft. 4 in.)
Breakout Force	8604 kg (18,968 lb.)	8929 kg (19,684 lb.)
Tipping Load, Straight	8791 kg (19,382 lb.)	9002 kg (19,847 lb.)
Tipping Load, 40-Deg. Full Turn	7554 kg (16,654 lb.)	7751 kg (17,089 lb.)
Reach, 45-Deg. Dump, 2.13-m (7 ft.)		
Clearance	1.51 m (5 ft. 0 in.)	1.48 m (4 ft. 10 in.)
▲▲ Reach, 45-Deg. Dump, Full Height	1.09 m (3 ft. 7 in.)	1.02 m (3 ft. 4 in.)
▲ Dump Clearance, 45 Deg., Full Height	2.68 m (8 ft. 9 in.)	2.70 m (8 ft. 10 in.)
▲▲▲ Overall Length, Bucket on Ground	7.69 m (25 ft. 3 in.)	7.63 m (25 ft. 0 in.)
Loader Clearance Circle, Bucket Carry		
Position	12.10 m (39 ft. 8 in.)	11.93 m (39 ft. 2 in.)
Operating Weight	13 840 kg (30,511 lb.)	13 737 kg (30,285 lb.)

Loader operating information is based on machine with identified linkage and standard equipment, ROPS cab, rear cast bumper/counterweight, transmission side-frame guards, bottom guards, standard tires, full fuel tank, and 79-kg (175 lb.) operator. This information is affected by changes in tires, ballast, and different attachments, and assumes no tire deflection per the standard ISO 14397-1 section 5.

### Specifications with Quick-Coupler and Hook-On Construction Fork

	Z-Bar		High-Lift		Powerllel	
▲ Tine Length	1.22 m (48 in.)	1.52 m (60 in.)	1.22 m (48 in.)	1.52 m (60 in.)	1.22 m (48 in.)	1.52 m (60 in.)
▲▲ Overall Length	7.89 m (25 ft. 11 in.)	8.19 m (26 ft. 10 in.)	8.22 m (27 ft. 0 in.)	8.52 m (27 ft. 11 in.)	7.99 m (26 ft. 3 in.)	8.29 m (27 ft. 2 in.)
Tipping Load, Straight (fork level, load centered and positioned at 50% tine length)	7630 kg (16,821 lb.)	6932 kg (15,282 lb.)	6867 kg (15,139 lb.)	6504 kg (14,340 lb.)	7218 kg (15,913 lb.)	6757 kg (14,897 lb.)
Tipping Load, 40-Deg. Full Turn (fork level, load centered and positioned at 50% tine length)	6608 kg (14,568 lb.)	5998 kg (13,223 lb.)	5931 kg (13,076 lb.)	5612 kg (12,372 lb.)	6244 kg (13,766 lb.)	5829 kg (12,851 lb.)
Operating Weight	12 797 kg (28,213 lb.)	12 840 kg (28,307 lb.)	12 897 kg (28,433 lb.)	12 940 kg (28,528 lb.)	13 466 kg (29,687 lb.)	13 585 kg (29,949 lb.)

Loader operating information is based on machine with identified linkage and standard equipment, ROPS cab, rear cast bumper/counterweight, transmission side-frame guards, bottom guards, standard tires, full fuel tank, and 79-kg (175 lb.) operator. This information is affected by changes in tires, ballast, and different attachments, and assumes no tire deflection per the standard ISO 14397-1 section 5.

### Adjustments to Operating Weights and Tipping Loads with Buckets

Adjustments to operating weights and tipping loads are based on Z-bar machine and pin-on 2.3-m<sup>3</sup> (3.0 cu. yd.) narrow general-purpose bucket with bolt-on cutting edge, ROPS cab, rear cast bumper/counterweight, transmission side-frame guards, bottom guards, standard tires, full fuel tank, and 79-kg (175 lb.) operator\*

Add (+) or deduct (-) lb. (kg) as indicated for loaders with 3-piece rims and	Operating Weight	Tipping Load, Straight	Tipping Load, 40-Deg. Full Turn, SAE
20.5 R 25, 1 Star L-3	0 kg (0 lb.)	0 kg (0 lb.)	0 kg (0 lb.)
20.5 R 25, 1 Star L-2	- 148 kg (- 326 lb.)	- 104 kg (- 229 lb.)	- 91 kg (- 201 lb.)
20.5-25, 16 PR L-2	- 324 kg (- 714 lb.)	- 227 kg (- 500 lb.)	- 200 kg (- 441 lb.)
20.5-25, 12 PR L-2	- 297 kg (- 655 lb.)	- 208 kg (- 458 lb.)	- 183 kg (- 404 lb.)
20.5-25, 16 PR L-3	- 228 kg (- 503 lb.)	- 160 kg (- 352 lb.)	- 140 kg (- 309 lb.)
600/65 R 25, 1 Star L-3T <sup>§</sup>	+ 28 kg (+ 63 lb.)	+ 20 kg (+ 43 lb.)	+ 17 kg (+ 37 lb.)
23.1-26 Logger <sup>†</sup>	- 10 kg (- 22 lb.)	- 7 kg (- 15 lb.)	- 7 kg (- 15 lb.)
CaCl <sub>2</sub> in 20.5-25, L-3 rear tires	+ 824 kg (+ 1,817 lb.)	+ 1154 kg (+ 2,543 lb.)	+ 1018 kg (+ 2,243 lb.)
Rear cast bumper/counterweight (removed)	- 104 kg (- 229 lb.)	- 252 kg (- 556 lb.)	- 210 kg (- 463 lb.)

\*May change based on vehicle configuration, weight, or tire-pressure adjustments.

<sup>§</sup>CaCl<sub>2</sub> not recommended.

<sup>†</sup>Equipped with one-piece rims.



Bucket Selection Guides\*

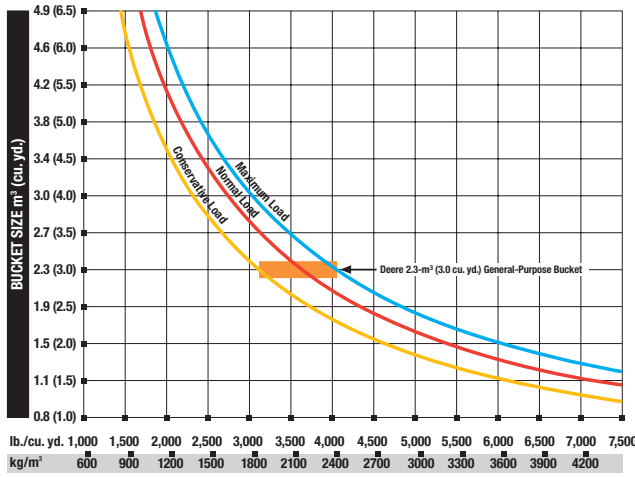

544K Z-BAR LOADER WITH PIN-ON BUCKET

LOOSE MATERIALS	kg/m³	lb./cu. yd.
Chips, pulpwood	288	486
Cinders (coal, ashes, clinkers)	673	1,134
Clay and gravel, dry	1602	2,700
Clay, compact, solid	1746	2,943
Clay, dry in lump loose	1009	1,701
Clay, excavated in water	1282	2,160
Coal, anthracite, broken, loose	865	1,458
Coal, bituminous, moderately wet	801	1,350
Earth, common loam, dry	1218	2,052
Earth, mud, packed	1843	3,105
Granite, broken	1538	2,592
Gypsum	2275	3,834
Limestone, coarse, sized	1570	2,646
Limestone, mixed sizes	1682	2,835
Limestone, pulverized or crushed	1362	2,295
Sand, damp	2083	3,510
Sand, dry	1762	2,970
Sand, voids, full of water	2083	3,510
Sandstone, quarried	1314	2,214
Shale, broken crushed	1362	2,295
Slag, furnace granulated	1955	3,294
Stone or gravel, 37.5 to 87.5-mm (1.5 to 3.5") size	1442	2,430
Stone or gravel, 18.75-mm (3/4") size	1602	2,700

\* This guide, representing bucket sizes not necessarily manufactured by Deere, will help you in selecting proper bucket size for material density, loader configuration, and operating conditions. Optimum bucket size is determined after adding or subtracting all tipping load changes due to optional equipment. The "conservative load" line on this guide is recommended when operating in conditions such as soft ground and unlevel surfaces. The "maximum load" condition on this guide is sometimes utilized when operating on firm ground and level surfaces.

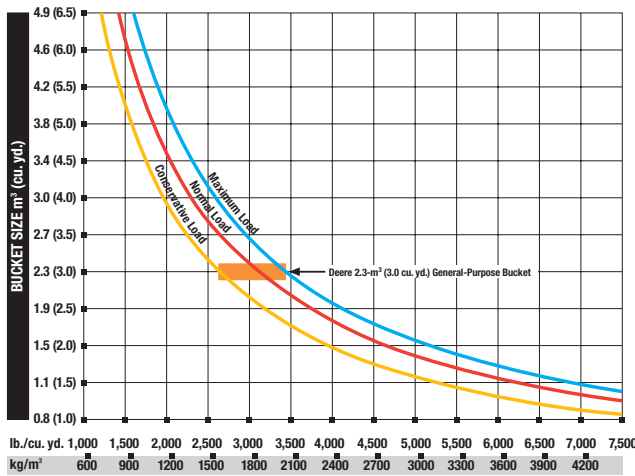

544K HIGH-LIFT LOADER WITH PIN-ON BUCKET

LOOSE MATERIALS	kg/m³	lb./cu. yd.
Chips, pulpwood	288	486
Cinders (coal, ashes, clinkers)	673	1,134
Clay and gravel, dry	1602	2,700
Clay, compact, solid	1746	2,943
Clay, dry in lump loose	1009	1,701
Clay, excavated in water	1282	2,160
Coal, anthracite, broken, loose	865	1,458
Coal, bituminous, moderately wet	801	1,350
Earth, common loam, dry	1218	2,052
Earth, mud, packed	1843	3,105
Granite, broken	1538	2,592
Gypsum	2275	3,834
Limestone, coarse, sized	1570	2,646
Limestone, mixed sizes	1682	2,835
Limestone, pulverized or crushed	1362	2,295
Sand, damp	2083	3,510
Sand, dry	1762	2,970
Sand, voids, full of water	2083	3,510
Sandstone, quarried	1314	2,214
Shale, broken crushed	1362	2,295
Slag, furnace granulated	1955	3,294
Stone or gravel, 37.5 to 87.5-mm (1.5 to 3.5") size	1442	2,430
Stone or gravel, 18.75-mm (3/4") size	1602	2,700

\* This guide, representing bucket sizes not necessarily manufactured by Deere, will help you in selecting proper bucket size for material density, loader configuration, and operating conditions. Optimum bucket size is determined after adding or subtracting all tipping load changes due to optional equipment. The "conservative load" line on this guide is recommended when operating in conditions such as soft ground and unlevel surfaces. The "maximum load" condition on this guide is sometimes utilized when operating on firm ground and level surfaces.

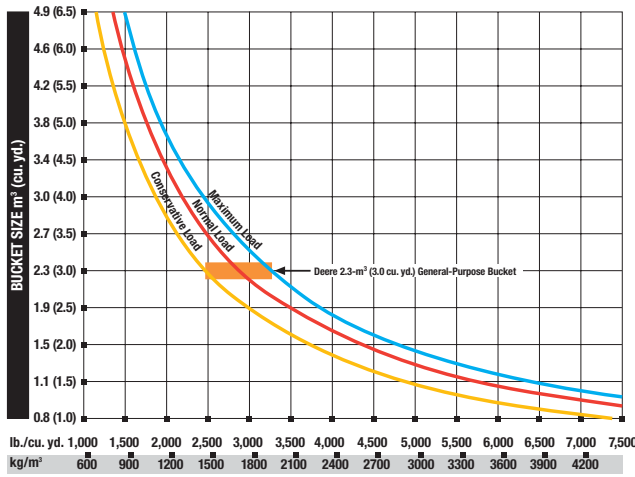

544K POWERLEL LOADER WITH QUICK-COUPLER AND HOOK-ON BUCKET

LOOSE MATERIALS	kg/m³	lb./cu. yd.
Chips, pulpwood	288	486
Cinders (coal, ashes, clinkers)	673	1,134
Clay and gravel, dry	1602	2,700
Clay, compact, solid	1746	2,943
Clay, dry in lump loose	1009	1,701
Clay, excavated in water	1282	2,160
Coal, anthracite, broken, loose	865	1,458
Coal, bituminous, moderately wet	801	1,350
Earth, common loam, dry	1218	2,052
Earth, mud, packed	1843	3,105
Granite, broken	1538	2,592
Gypsum	2275	3,834
Limestone, coarse, sized	1570	2,646
Limestone, mixed sizes	1682	2,835
Limestone, pulverized or crushed	1362	2,295
Sand, damp	2083	3,510
Sand, dry	1762	2,970
Sand, voids, full of water	2083	3,510
Sandstone, quarried	1314	2,214
Shale, broken crushed	1362	2,295
Slag, furnace granulated	1955	3,294
Stone or gravel, 37.5 to 87.5-mm (1.5 to 3.5") size	1442	2,430
Stone or gravel, 18.75-mm (3/4") size	1602	2,700

\* This guide, representing bucket sizes not necessarily manufactured by Deere, will help you in selecting proper bucket size for material density, loader configuration, and operating conditions. Optimum bucket size is determined after adding or subtracting all tipping load changes due to optional equipment. The "conservative load" line on this guide is recommended when operating in conditions such as soft ground and unlevel surfaces. The "maximum load" condition on this guide is sometimes utilized when operating on firm ground and level surfaces.

# Specifications

624K

Engine	624K Z-BAR / HIGH-LIFT / POWERLLEL™ / TOOL CARRIER	
Manufacturer and Model	John Deere PowerTech™ Plus 6068H	John Deere PowerTech 6068H
Non-Road Emissions Standard	EPA Tier 3/EU Stage IIIA	EPA Tier 2/EU Stage II
Cylinders	6	6
Valves Per Cylinder	4	4
Displacement	6.8 L (414 cu. in.)	6.8 L (414 cu. in.)
Net Peak Power @ 1,800 rpm	147 kW (198 hp)	147 kW (198 hp)
Net Peak Torque @ 1,600 rpm	836 Nm (617 lb.-ft.)	836 Nm (617 lb.-ft.)
Net Torque Rise	55%	55%
Fuel System (electronically controlled)	high-pressure common rail	high-pressure common rail
Lubrication	full-flow spin-on filter and integral cooler	full-flow spin-on filter and integral cooler
Aspiration	turbocharged, charge air cooled	turbocharged, charge air cooled
Air Cleaner	under-hood, dual-element dry type, restriction indicator in cab monitor for service	under-hood, dual-element dry type, restriction indicator in cab monitor for service
Fan Drive	hydraulically driven, proportionally controlled, fan aft of coolers	hydraulically driven, proportionally controlled, fan aft of coolers
Electrical System	24 volt with 80-amp alternator (100-amp alternator optional)	24 volt with 80-amp alternator (100-amp alternator optional)
Batteries (2 – 12 volt)	950 CCA (each)	950 CCA (each)

Transmission		
Type	countershaft-type PowerShift™	
Torque Converter	single stage, single phase	
Shift Control	electronically modulated, adaptive, load and speed dependent	
Operator Interface	steering-column or joystick-mounted F-N-R and gear-select lever; quick-shift button on hydraulic lever	
Shift Modes	manual/auto (1st-D or 2nd-D); quick-shift button with 2 selectable modes: kick-down or kick-up/down; and 3 adjustable clutch-cutoff settings	
Travel Speeds (with 20.5-25 tires)	<i>Forward Maximum</i>	<i>Reverse Maximum</i>
Gear 1	7.6 km/h (4.7 mph)	7.6 km/h (4.7 mph)
Gear 2	12.5 km/h (7.8 mph)	13.0 km/h (8.1 mph)
Gear 3	25.0 km/h (15.5 mph)	25.7 km/h (16.0 mph)
Gear 4	39.5 km/h (24.5 mph)	N/A

Axles/Brakes	
Final Drives	heavy-duty inboard-mounted planetary
Differentials	hydraulic locking front with conventional rear — standard; dual locking front and rear — optional
Rear Axle Oscillation, Stop to Stop (with 20.5-25 tires)	24 deg. (12 deg. per side)
Brakes (conform to ISO 3450)	
Service Brakes	hydraulically actuated, inboard sun-shaft mounted, oil cooled, self adjusting, single disc
Parking Brake	automatic spring applied, hydraulically released, driveline mounted, oil cooled, multi disc

Tires	Tread Width	Width Over Tires	Change In Vertical Height
Choice of (with 3-piece rims)*			standard
20.5 R 25, 1 Star L-3	2050 mm (80.7 in.)	2657 mm (104.6 in.)	– 3 mm (– 0.1 in.)
20.5 R 25, 1 Star L-2	2050 mm (80.7 in.)	2641 mm (104.0 in.)	+ 6 mm (+ 0.2 in.)
20.5-25, 16 PR L-2	2050 mm (80.7 in.)	2645 mm (104.1 in.)	+ 13 mm (+ 0.5 in.)
20.5-25, 16 PR L-3	2050 mm (80.7 in.)	2740 mm (107.9 in.)	– 24 mm (– 0.9 in.)
600/65 R 25, 1 Star L-3T <sup>§</sup>	2050 mm (80.7 in.)	2983 mm (117.4 in.)	+ 90 mm (+ 3.5 in.)
28L-26 Logger <sup>†</sup>	2272 mm (89.4 in.)		

\*Based on Z-bar machine configuration; may change based on vehicle configuration, weight, or tire-pressure adjustments.

<sup>§</sup>CaCl<sub>2</sub> not recommended.

<sup>†</sup>Equipped with one-piece rims.

## Refill Capacities (U.S.)

## 624K Z-BAR / HIGH-LIFT / POWERLLEL / TOOL CARRIER

Fuel Tank (with ground-level fueling) . . . . .	352 L (93 gal.)
Cooling System . . . . .	27 L (29 qt.)
Engine Oil with Vertical Spin-On Filter . . . . .	19 L (20 qt.)
Transmission Fluid with Vertical Filter . . . . .	21 L (22 qt.)
Axle Oil	
Front . . . . .	22 L (23 qt.)
Rear . . . . .	17 L (18 qt.)
Hydraulic Reservoir and Filters . . . . .	110 L (29 gal.)
Park Brake Oil (wet disc) . . . . .	0.3 L (10 oz.)

## Hydraulic System/Steering

Pump (loader and steering) . . . . .	variable-displacement, axial-piston pump; closed-center, pressure-compensating system			
Maximum Rated Flow @ 6895 kPa (1,000 psi) and 2,350 rpm . . . . .	223 L/m (59 gpm)			
System Relief Pressure (loader and steering) . . . . .	24 821 kPa (3,675 psi)			
Loader Controls . . . . .	2-function valve, joystick control or fingertip controls, hydraulic-function enable/disable, optional 3rd- and 4th-function valve with auxiliary lever			
Steering (conforms to ISO 5010)				
Typepower, fully hydraulic				
Articulation Angle . . . . .	80-deg. arc (40 deg. each direction)			
Hydraulic Cycle Times . . . . .	<b>Z-Bar</b>	<b>High-Lift</b>	<b>Powerllel</b>	<b>Tool Carrier</b>
Raise . . . . .	5.9 sec.	5.9 sec.	5.9 sec.	5.6 sec.
Dump . . . . .	1.3 sec.	1.3 sec.	1.4 sec.	3.0 sec.
Lower (float down) . . . . .	2.7 sec.	2.7 sec.	2.8 sec.	2.7 sec.
Total . . . . .	9.9 sec.	9.9 sec.	10.1 sec.	11.3 sec.
Turning Radius (measured to centerline of outside tire) . . . . .	5.27 m (17 ft. 4 in.)			

## Dimensions with Standard Configuration

	<b>Z-Bar</b> 2.7-m <sup>3</sup> (3.5 cu. yd.) pin-on bucket	<b>High-Lift</b> 2.7-m <sup>3</sup> (3.5 cu. yd.) pin-on bucket	<b>Powerllel</b> 2.7-m <sup>3</sup> (3.5 cu. yd.) hook-on bucket with coupler
<b>A</b> Height to Top of Cab and Canopy . . . . .	3.32 m (10 ft. 11 in.)	3.32 m (10 ft. 11 in.)	3.32 m (10 ft. 11 in.)
<b>B</b> Ground Clearance . . . . .	384 mm (15.1 in.)	384 mm (15.1 in.)	384 mm (15.1 in.)
<b>C</b> Length from Centerline to Front Axle . . . . .	1.52 m (5 ft. 0 in.)	1.52 m (5 ft. 0 in.)	1.52 m (5 ft. 0 in.)
<b>D</b> Wheelbase . . . . .	3.09 m (10 ft. 1 in.)	3.09 m (10 ft. 1 in.)	3.09 m (10 ft. 1 in.)
<b>E</b> Dump Clearance . . . . .	▲ (see page 37)	▲ (see page 37)	▲ (see page 38)
<b>F</b> Height to Hinge Pin, Fully Raised . . . . .	3.95 m (13 ft. 0 in.)	4.30 m (14 ft. 2 in.)	3.99 m (13 ft. 1 in.)
<b>G</b> Dump Reach . . . . .	▲▲ (see page 37)	▲▲ (see page 37)	▲▲ (see page 38)
<b>H</b> Maximum Digging Depth . . . . .	95 mm (3.8 in.)	196 mm (7.7 in.)	119 mm (4.7 in.)
<b>I</b> Overall Length . . . . .	▲▲▲ (see page 37)	▲▲▲ (see page 37)	▲▲▲ (see page 38)
<b>J</b> Maximum Rollback at Ground Level . . . . .	37 deg.	36 deg.	42 deg.
<b>K</b> Maximum Rollback, Boom Fully Raised . . . . .	50 deg.	49 deg.	52 deg.
<b>L</b> Maximum Bucket Angle, Fully Raised . . . . .	45 deg.	46 deg.	46 deg.

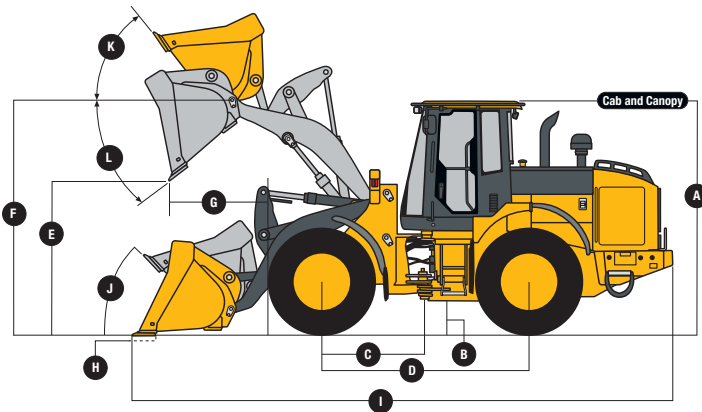

624K Z-BAR AND HIGH-LIFT LOADERS

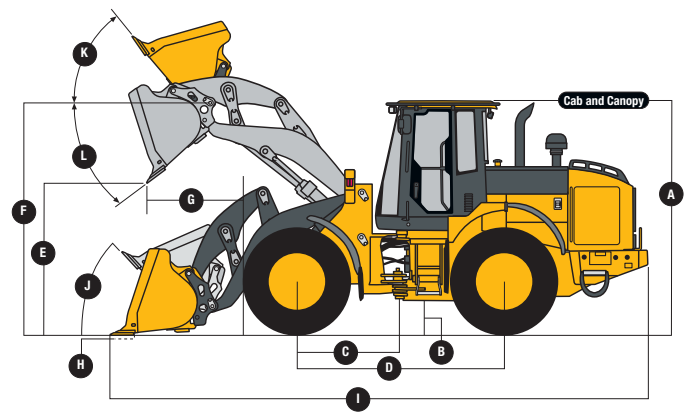

624K POWERLLEL LOADER

**Dimensions with Quick-Coupler and Hook-On Bucket**

**624K Z-BAR / HIGH-LIFT / POWERLLEL**

	Z-Bar	High-Lift	Powerllel
<b>A</b> Dump Clearance	▲ (see page 37)	▲ (see page 38)	▲ (see page 38)
<b>B</b> Dump Reach	▲▲ (see page 37)	▲▲ (see page 38)	▲▲ (see page 38)
<b>C</b> Maximum Digging Depth	165 mm (6.5 in.)	262 mm (10.3 in.)	119 mm (4.7 in.)
<b>D</b> Height to Hinge Pin, Fully Raised	3.96 m (13 ft. 0 in.)	4.32 m (14 ft. 2 in.)	3.99 m (13 ft. 1 in.)
<b>E</b> Overall Length	▲▲▲ (see page 37)	▲▲▲ (see page 38)	▲▲▲ (see page 38)
<b>F</b> Maximum Rollback, Boom Fully Raised	55 deg.	48 deg.	52 deg.
<b>G</b> Maximum Bucket Angle, Fully Raised	45 deg.	42 deg.	46 deg.
<b>H</b> Maximum Rollback at Ground Level	39 deg.	39 deg.	42 deg.

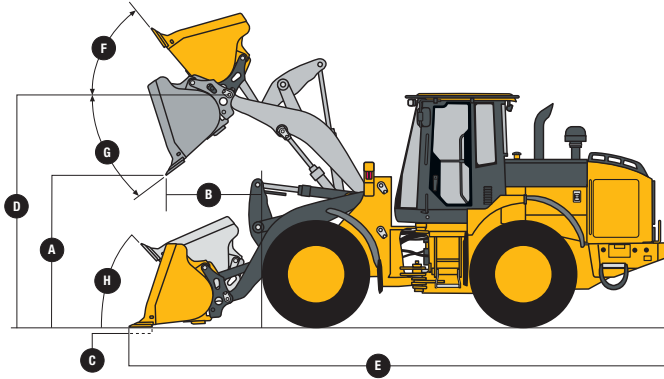

**624K Z-BAR AND HIGH-LIFT LOADERS WITH QUICK-COUPLER AND HOOK-ON BUCKET**

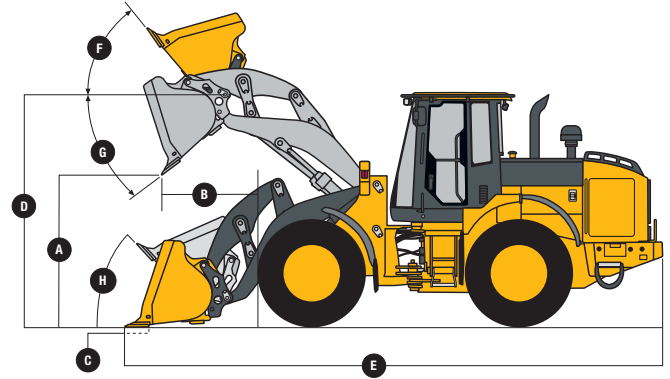

**624K POWERLLEL LOADER WITH QUICK-COUPLER AND HOOK-ON BUCKET**

**Dimensions with Quick-Coupler and Hook-On Construction Fork**

	Z-Bar	High-Lift	Powerllel
<b>A</b> Reach, Fully Raised	0.75 m (29 in.)	0.84 m (33 in.)	0.92 m (36 in.)
<b>B</b> Fork Height, Fully Raised	3.73 m (12 ft. 3 in.)	4.09 m (13 ft. 5 in.)	3.76 m (12 ft. 4 in.)
<b>C</b> Maximum Reach, Fork Level	1.58 m (5 ft. 2 in.)	1.92 m (6 ft. 4 in.)	1.77 m (5 ft. 10 in.)
<b>D</b> Maximum Reach, Fork Height	1.77 m (5 ft. 10 in.)	1.77 m (5 ft. 10 in.)	1.84 m (6 ft. 1 in.)
<b>E</b> Reach, Ground Level	0.96 m (3 ft. 2 in.)	1.40 m (4 ft. 7 in.)	1.11 m (3 ft. 8 in.)
<b>F</b> Depth Below Ground	23 mm (0.9 in.)	123 mm (4.8 in.)	19 mm (0.8 in.)
<b>G</b> Tine Length	▲ (see page 38)	▲ (see page 38)	▲ (see page 38)
<b>H</b> Overall Length	▲▲ (see page 38)	▲▲ (see page 38)	▲▲ (see page 38)

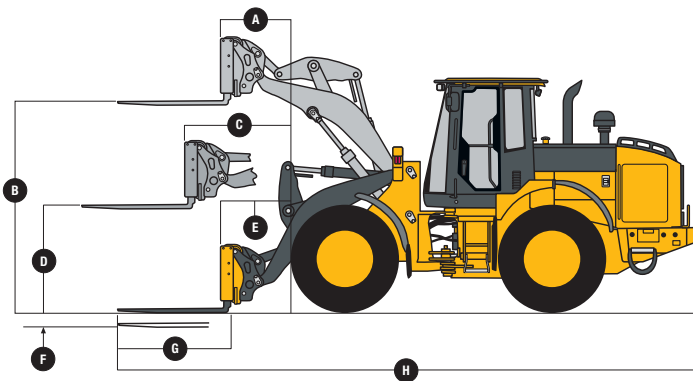

**624K Z-BAR AND HIGH-LIFT LOADERS WITH QUICK-COUPLER AND HOOK-ON CONSTRUCTION FORK**

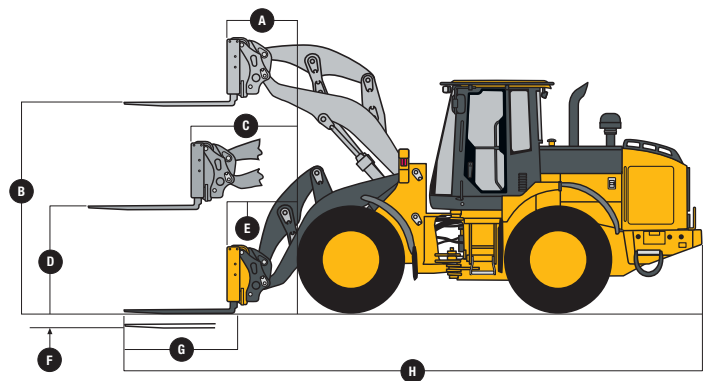

**624K POWERLLEL LOADER WITH QUICK-COUPLER AND HOOK-ON CONSTRUCTION FORK**

## 624K Z-Bar with Pin-On-Type Bucket

	<i>General-Purpose with Bolt-On Edge</i>
Bucket Type/Size	
Capacity, Heaped	2.7 m <sup>3</sup> (3.5 cu. yd.)
Capacity, Struck	2.3 m <sup>3</sup> (3.0 cu. yd.)
Bucket Weight	1148 kg (2,532 lb.)
Bucket Width	2.69 m (8 ft. 10 in.)
Breakout Force	12 920 kg (28,484 lb.)
Tipping Load, Straight	13 922 kg (30,693 lb.)
Tipping Load, 40-Deg. Full Turn	12 031 kg (26,524 lb.)
Reach, 45-Deg. Dump, 2.13-m (7 ft.)	
Clearance	1.57 m (5 ft. 2 in.)
▲▲ Reach, 45-Deg. Dump, Full Height	1.02 m (3 ft. 4 in.)
▲ Dump Clearance, 45 Deg., Full Height	2.86 m (9 ft. 5 in.)
▲▲▲ Overall Length, Bucket on Ground	7.76 m (25 ft. 5 in.)
Loader Clearance Circle, Bucket Carry	
Position	12.24 m (40 ft. 2 in.)
Operating Weight	15 185 kg (33,477 lb.)

Loader operating information is based on machine with identified linkage and standard equipment, ROPS cab, rear cast bumper/counterweight, transmission side-frame guards, bottom guards, standard tires, full fuel tank, and 79-kg (175 lb.) operator. This information is affected by changes in tires, ballast, and different attachments, and assumes no tire deflection per the standard ISO 14397-1 section 5.

## 624K High-Lift with Pin-On-Type Bucket

	<i>General-Purpose with Bolt-On Edge</i>
Bucket Type/Size	
Capacity, Heaped	2.7 m <sup>3</sup> (3.5 cu. yd.)
Capacity, Struck	2.3 m <sup>3</sup> (3.0 cu. yd.)
Bucket Weight	1149 kg (2,532 lb.)
Bucket Width	2.69 m (8 ft. 10 in.)
Breakout Force	11 741 kg (25,884 lb.)
Tipping Load, Straight	11 559 kg (25,483 lb.)
Tipping Load, 40-Deg. Full Turn	9956 kg (21,949 lb.)
Reach, 45-Deg. Dump, 2.13-m (7 ft.)	
Clearance	1.93 m (6 ft. 4 in.)
▲▲ Reach, 45-Deg. Dump, Full Height	1.11 m (3 ft. 8 in.)
▲ Dump Clearance, 45 Deg., Full Height	3.23 m (10 ft. 7 in.)
▲▲▲ Overall Length, Bucket on Ground	8.17 m (26 ft. 9 in.)
Loader Clearance Circle, Bucket Carry	
Position	12.61 m (41 ft. 4 in.)
Operating Weight	15 319 kg (33,773 lb.)

Loader operating information is based on machine with identified linkage and standard equipment, ROPS cab, rear cast bumper/counterweight, transmission side-frame guards, bottom guards, standard tires, full fuel tank, and 79-kg (175 lb.) operator. This information is affected by changes in tires, ballast, and different attachments, and assumes no tire deflection per the standard ISO 14397-1 section 5.

## 624K Z-Bar with Quick-Coupler and Hook-On-Type Bucket

	<i>General-Purpose with Bolt-On Edge</i>
Bucket Type/Size	
Capacity, Heaped	2.7 m <sup>3</sup> (3.5 cu. yd.)
Capacity, Struck	2.3 m <sup>3</sup> (3.0 cu. yd.)
Bucket Weight with Coupler	1532 kg (3,378 lb.)
Bucket Width	2.69 m (8 ft. 10 in.)
Breakout Force	11 090 kg (24,449 lb.)
Tipping Load, Straight	12 506 kg (27,571 lb.)
Tipping Load, 40-Deg. Full Turn	10 757 kg (23,715 lb.)
Reach, 45-Deg. Dump, 2.13-m (7 ft.)	
Clearance	1.56 m (5 ft. 2 in.)
▲▲ Reach, 45-Deg. Dump, Full Height	1.11 m (3 ft. 8 in.)
▲ Dump Clearance, 45 Deg., Full Height	2.69 m (8 ft. 10 in.)
▲▲▲ Overall Length, Bucket on Ground	7.98 m (26 ft. 2 in.)
Loader Clearance Circle, Bucket Carry	
Position	12.38 m (40 ft. 7 in.)
Operating Weight	15 554 kg (34,291 lb.)

Loader operating information is based on machine with identified linkage and standard equipment, ROPS cab, rear cast bumper/counterweight, transmission side-frame guards, bottom guards, standard tires, full fuel tank, and 79-kg (175 lb.) operator. This information is affected by changes in tires, ballast, and different attachments, and assumes no tire deflection per the standard ISO 14397-1 section 5.

## 624K High-Lift with Quick-Coupler and Hook-On-Type Bucket

	General-Purpose with Bolt-On Edge
Bucket Type/Size	
Capacity, Heaped	2.7 m <sup>3</sup> (3.5 cu. yd.)
Capacity, Struck	2.3 m <sup>3</sup> (3.0 cu. yd.)
Bucket Weight with Coupler	1532 kg (3,378 lb.)
Bucket Width	2.69 m (8 ft. 10 in.)
Breakout Force	10 075 kg (22,212 lb.)
Tipping Load, Straight	10 421 kg (22,974 lb.)
Tipping Load, 40-Deg. Full Turn	8924 kg (19,674 lb.)
Reach, 45-Deg. Dump, 2.13-m (7 ft.) Clearance	1.94 m (6 ft. 4 in.)
▲▲ Reach, 45-Deg. Dump, Full Height	1.20 m (3 ft. 11 in.)
▲ Dump Clearance, 45 Deg., Full Height	3.06 m (10 ft. 1 in.)
▲▲▲ Overall Length, Bucket on Ground	8.39 m (27 ft. 6 in.)
Loader Clearance Circle, Bucket Carry Position	12.77 m (41 ft. 11 in.)
Operating Weight	15 697 kg (34,606 lb.)

Loader operating information is based on machine with identified linkage and standard equipment, ROPS cab, rear cast bumper/counterweight, transmission side-frame guards, bottom guards, standard tires, full fuel tank, and 79-kg (175 lb.) operator. This information is affected by changes in tires, ballast, and different attachments, and assumes no tire deflection per the standard ISO 14397-1 section 5.

## 624K Powerllel with Quick-Coupler and Hook-On-Type Bucket

	General-Purpose with Bolt-On Edge	Powerllel
Bucket Type/Size		
Capacity, Heaped	2.7 m <sup>3</sup> (3.5 cu. yd.)	2.3 m <sup>3</sup> (3.0 cu. yd.)
Capacity, Struck	2.3 m <sup>3</sup> (3.0 cu. yd.)	1.9 m <sup>3</sup> (2.5 cu. yd.)
Bucket Weight with Coupler	1562 kg (3,444 lb.)	1492 kg (3,289 lb.)
Bucket Width	2.69 m (8 ft. 10 in.)	2.69 m (8 ft. 10 in.)
Breakout Force	10 759 kg (23,719 lb.)	11 734 kg (25,870 lb.)
Tipping Load, Straight	10 802 kg (23,814 lb.)	11 015 kg (24,283 lb.)
Tipping Load, 40-Deg. Full Turn	9257 kg (20,408 lb.)	9452 kg (20,837 lb.)
Reach, 45-Deg. Dump, 2.13-m (7 ft.) Clearance	1.75 m (5 ft. 9 in.)	1.71 m (5 ft. 7 in.)
▲▲ Reach, 45-Deg. Dump, Full Height	1.28 m (4 ft. 2 in.)	1.20 m (3 ft. 11 in.)
▲ Dump Clearance, 45 Deg., Full Height	2.70 m (8 ft. 10 in.)	2.78 m (9 ft. 2 in.)
▲▲▲ Overall Length, Bucket on Ground	8.13 m (26 ft. 8 in.)	8.01 m (26 ft. 3 in.)
Loader Clearance Circle, Bucket Carry Position	12.60 m (41 ft. 4 in.)	12.30 m (40 ft. 4 in.)
Operating Weight	16 454 kg (36,275 lb.)	16 384 kg (36,121 lb.)

Loader operating information is based on machine with identified linkage and standard equipment, ROPS cab, rear cast bumper/counterweight, transmission side-frame guards, bottom guards, standard tires, full fuel tank, and 79-kg (175 lb.) operator. This information is affected by changes in tires, ballast, and different attachments, and assumes no tire deflection per the standard ISO 14397-1 section 5.

## Specifications with Quick-Coupler and Hook-On Construction Fork

	Z-Bar	High-Lift	Powerllel
▲ Tine Length	1.22 m (48 in.)	1.52 m (60 in.)	1.22 m (48 in.)
▲▲ Overall Length	8.18 m (26 ft. 10 in.)	8.48 m (27 ft. 10 in.)	8.30 m (27 ft. 3 in.)
Tipping Load, Straight (fork level, load centered and positioned at 50% tine length)	9740 kg (21,473 lb.)	9213 kg (20,311 lb.)	8593 kg (18,945 lb.)
Tipping Load, 40-Deg. Full Turn (fork level, load centered and positioned at 50% tine length)	8417 kg (18,556 lb.)	7955 kg (17,538 lb.)	7404 kg (16,323 lb.)
Operating Weight	15 228 kg (33,572 lb.)	15 271 kg (33,667 lb.)	15 371 kg (33,887 lb.)

Loader operating information is based on machine with identified linkage and standard equipment, ROPS cab, rear cast bumper/counterweight, transmission side-frame guards, bottom guards, standard tires, full fuel tank, and 79-kg (175 lb.) operator. This information is affected by changes in tires, ballast, and different attachments, and assumes no tire deflection per the standard ISO 14397-1 section 5.

## Adjustments to Operating Weights and Tipping Loads with Buckets

Adjustments to operating weights and tipping loads are based on Z-bar machine and pin-on 2.3-m<sup>3</sup> (3.0 cu. yd.) narrow general-purpose bucket with bolt-on cutting edge, ROPS cab, rear cast bumper/counterweight, transmission side-frame guards, bottom guards, standard tires, full fuel tank, and 79-kg (175 lb.) operator\*

Add (+) or deduct (-) lb. (kg) as indicated for loaders with 3-piece rims and	Operating Weight	Tipping Load, Straight	Tipping Load, 40-Deg. Full Turn, SAE
20.5 R 25, 1 Star L-3	0 kg (0 lb.)	0 kg (0 lb.)	0 kg (0 lb.)
20.5 R 25, 1 Star L-2	- 158 kg (- 349 lb.)	- 119 kg (- 263 lb.)	- 104 kg (- 230 lb.)
20.5-25, 16 PR L-2	- 324 kg (- 714 lb.)	- 244 kg (- 538 lb.)	- 214 kg (- 472 lb.)
20.5-25, 16 PR L-3	- 228 kg (- 503 lb.)	- 172 kg (- 379 lb.)	- 151 kg (- 332 lb.)
600/65 R 25, 1 Star L-3T <sup>§</sup>	+ 28 kg (+ 62 lb.)	+ 21 kg (+ 45 lb.)	+ 19 kg (+ 41 lb.)
28L-26 Logger <sup>†</sup>	+ 391 kg (+ 862 lb.)	+ 294 kg (+ 648 lb.)	+ 259 kg (+ 571 lb.)
CaCl <sub>2</sub> in 20.5-25, L-3 rear tires	+ 1166 kg (+ 2,571 lb.)	+ 1751 kg (+ 3,799 lb.)	+ 1543 kg (+ 3,355 lb.)
Rear cast bumper/counterweight (removed)	- 140 kg (- 309 lb.)	- 350 kg (- 772 lb.)	- 292 kg (- 644 lb.)

\*May change based on vehicle configuration, weight, or tire-pressure adjustments.

<sup>§</sup>CaCl<sub>2</sub> not recommended.

<sup>†</sup>Equipped with one-piece rims.

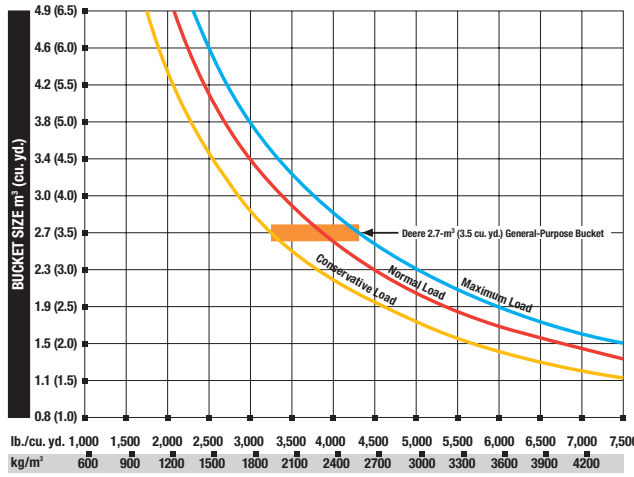

624K Z-BAR LOADER WITH PIN-ON BUCKET

LOOSE MATERIALS	kg/m <sup>3</sup>	lb./cu. yd.
Chips, pulpwood	288	486
Cinders (coal, ashes, clinkers)	673	1,134
Clay and gravel, dry	1602	2,700
Clay, compact, solid	1746	2,943
Clay, dry in lump loose	1009	1,701
Clay, excavated in water	1282	2,160
Coal, anthracite, broken, loose	865	1,458
Coal, bituminous, moderately wet	801	1,350
Earth, common loam, dry	1218	2,052
Earth, mud, packed	1843	3,105
Granite, broken	1538	2,592
Gypsum	2275	3,834
Limestone, coarse, sized	1570	2,646
Limestone, mixed sizes	1682	2,835
Limestone, pulverized or crushed	1362	2,295
Sand, damp	2083	3,510
Sand, dry	1762	2,970
Sand, voids, full of water	2083	3,510
Sandstone, quarried	1314	2,214
Shale, broken crushed	1362	2,295
Slag, furnace granulated	1955	3,294
Stone or gravel, 37.5 to 87.5-mm (1.5 to 3.5") size	1442	2,430
Stone or gravel, 18.75-mm (3/4") size	1602	2,700

\* This guide, representing bucket sizes not necessarily manufactured by Deere, will help you in selecting proper bucket size for material density, loader configuration, and operating conditions. Optimum bucket size is determined after adding or subtracting all tipping load changes due to optional equipment. The "conservative load" line on this guide is recommended when operating in conditions such as soft ground and unlevel surfaces. The "maximum load" condition on this guide is sometimes utilized when operating on firm ground and level surfaces.

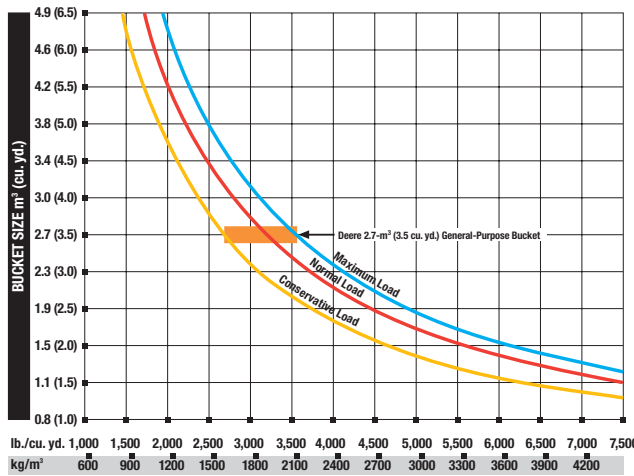

624K HIGH-LIFT LOADER WITH PIN-ON BUCKET

LOOSE MATERIALS	kg/m <sup>3</sup>	lb./cu. yd.
Chips, pulpwood	288	486
Cinders (coal, ashes, clinkers)	673	1,134
Clay and gravel, dry	1602	2,700
Clay, compact, solid	1746	2,943
Clay, dry in lump loose	1009	1,701
Clay, excavated in water	1282	2,160
Coal, anthracite, broken, loose	865	1,458
Coal, bituminous, moderately wet	801	1,350
Earth, common loam, dry	1218	2,052
Earth, mud, packed	1843	3,105
Granite, broken	1538	2,592
Gypsum	2275	3,834
Limestone, coarse, sized	1570	2,646
Limestone, mixed sizes	1682	2,835
Limestone, pulverized or crushed	1362	2,295
Sand, damp	2083	3,510
Sand, dry	1762	2,970
Sand, voids, full of water	2083	3,510
Sandstone, quarried	1314	2,214
Shale, broken crushed	1362	2,295
Slag, furnace granulated	1955	3,294
Stone or gravel, 37.5 to 87.5-mm (1.5 to 3.5") size	1442	2,430
Stone or gravel, 18.75-mm (3/4") size	1602	2,700

\* This guide, representing bucket sizes not necessarily manufactured by Deere, will help you in selecting proper bucket size for material density, loader configuration, and operating conditions. Optimum bucket size is determined after adding or subtracting all tipping load changes due to optional equipment. The "conservative load" line on this guide is recommended when operating in conditions such as soft ground and unlevel surfaces. The "maximum load" condition on this guide is sometimes utilized when operating on firm ground and level surfaces.

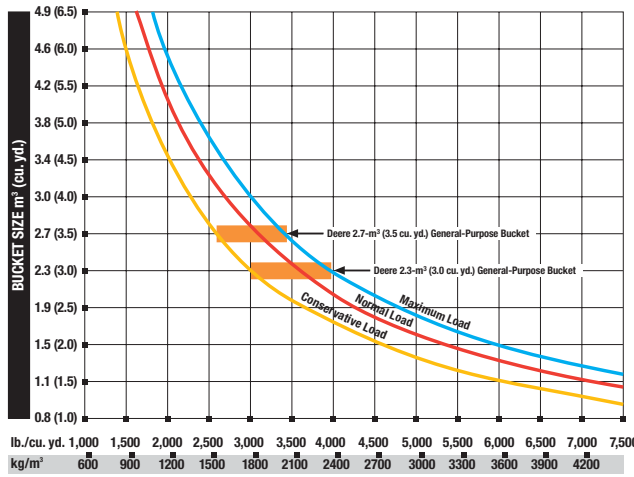

624K POWERLLEL LOADER WITH QUICK-COUPLER AND HOOK-ON BUCKET

LOOSE MATERIALS	kg/m <sup>3</sup>	lb./cu. yd.
Chips, pulpwood	288	486
Cinders (coal, ashes, clinkers)	673	1,134
Clay and gravel, dry	1602	2,700
Clay, compact, solid	1746	2,943
Clay, dry in lump loose	1009	1,701
Clay, excavated in water	1282	2,160
Coal, anthracite, broken, loose	865	1,458
Coal, bituminous, moderately wet	801	1,350
Earth, common loam, dry	1218	2,052
Earth, mud, packed	1843	3,105
Granite, broken	1538	2,592
Gypsum	2275	3,834
Limestone, coarse, sized	1570	2,646
Limestone, mixed sizes	1682	2,835
Limestone, pulverized or crushed	1362	2,295
Sand, damp	2083	3,510
Sand, dry	1762	2,970
Sand, voids, full of water	2083	3,510
Sandstone, quarried	1314	2,214
Shale, broken crushed	1362	2,295
Slag, furnace granulated	1955	3,294
Stone or gravel, 37.5 to 87.5-mm (1.5 to 3.5") size	1442	2,430
Stone or gravel, 18.75-mm (3/4") size	1602	2,700

\* This guide, representing bucket sizes not necessarily manufactured by Deere, will help you in selecting proper bucket size for material density, loader configuration, and operating conditions. Optimum bucket size is determined after adding or subtracting all tipping load changes due to optional equipment. The "conservative load" line on this guide is recommended when operating in conditions such as soft ground and unlevel surfaces. The "maximum load" condition on this guide is sometimes utilized when operating on firm ground and level surfaces.

**Dimensions with Standard Configuration 624K TOOL CARRIER**

2.7-m<sup>3</sup> (3.5 cu. yd.) pin-on bucket

- A Height to Top of Cab and Canopy . . . . . 3.32 m (10 ft. 11 in.)
- B Ground Clearance . . . . . 384 mm (15.1 in.)
- C Length from Centerline to Front Axle . . . . . 1.52 m (5 ft. 0 in.)
- D Wheelbase . . . . . 3.09 m (10 ft. 1 in.)
- E Dump Clearance . . . . . ▲ (see page 41)
- F Height to Hinge Pin, Fully Raised . . . . . 3.99 m (13 ft. 1 in.)
- G Dump Reach . . . . . ▲▲ (see page 41)
- H Maximum Digging Depth . . . . . 102 mm (4 in.)
- I Overall Length . . . . . ▲▲▲ (see page 41)
- J Maximum Rollback at Ground Level . . . . . 48.9 deg.
- K Maximum Rollback, Boom Fully Raised . . . . . 63.8 deg.
- L Maximum Bucket Angle, Fully Raised . . . . . 43.0 deg.

**Dimensions with Quick-Coupler and Hook-On Construction Fork**

- A Reach, Fully Raised . . . . . 0.89 m (35 in.)
- B Fork Height, Fully Raised . . . . . 3.91 m (12 ft. 10 in.)
- C Maximum Reach, Fork Level . . . . . 1.65 m (5 ft. 5 in.)
- D Maximum Reach, Fork Height . . . . . 1.99 m (6 ft. 7 in.)
- E Reach, Ground Level . . . . . 0.88 m (35 in.)
- F Depth Below Ground . . . . . 0 mm (0 in.)
- G Tine Length . . . . . ▲ (see page 41)
- H Overall Length . . . . . ▲▲ (see page 41)

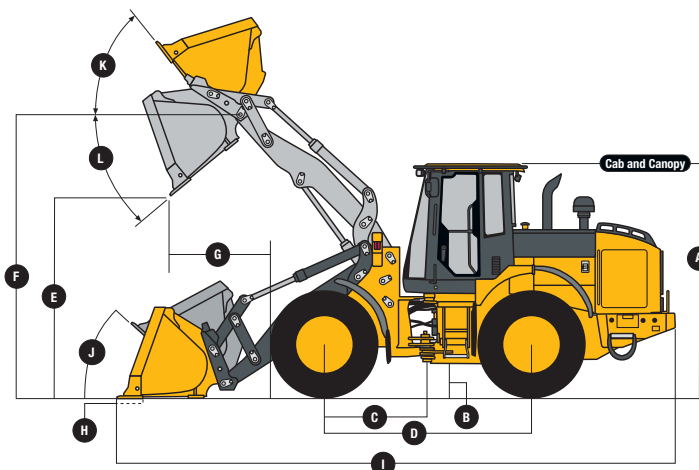

**624K TOOL-CARRIER LOADER WITH QUICK-COUPLER AND HOOK-ON BUCKET**

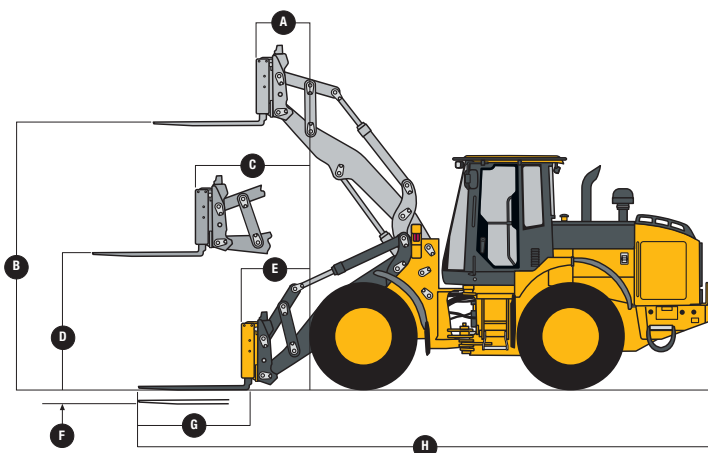

**624K TOOL-CARRIER LOADER WITH QUICK-COUPLER AND HOOK-ON CONSTRUCTION FORK**

**624K Tool Carrier with Pin-On-Type Bucket**

General-Purpose  
with Bolt-On Edge

- Bucket Type/Size
- Capacity, Heaped . . . . . 2.7 m<sup>3</sup> (3.5 cu. yd.)
- Capacity, Struck . . . . . 2.3 m<sup>3</sup> (3.0 cu. yd.)
- Bucket Weight . . . . . 1077 kg (2,375 lb.)
- Bucket Width . . . . . 2.69 m (8 ft. 10 in.)
- Breakout Force . . . . . 10 978 kg (24,202 lb.)
- Tipping Load, Straight . . . . . 12 431 kg (27,406 lb.)
- Tipping Load, 40-Deg. Full Turn . . . . . 10 739 kg (23,675 lb.)
- Reach, 45-Deg. Dump, 2.13-m (7 ft.)
- Clearance . . . . . 1.85 m (6 ft. 1 in.)
- ▲▲ Reach, 43-Deg. Dump, Full Height . . . . . 1.45 m (4 ft. 9 in.)
- ▲ Dump Clearance, 45 Deg., Full Height . . . . . 2.81 m (9 ft. 3 in.)
- ▲▲▲ Overall Length, Bucket on Ground . . . . . 7.95 m (26 ft. 1 in.)
- Loader Clearance Circle, Bucket Carry
- Position . . . . . 12.26 m (40 ft. 3 in.)
- Operating Weight . . . . . 15 499 kg (34,169 lb.)

Loader operating information is based on machine with identified linkage and standard equipment, ROPS cab, rear cast bumper/counterweight, transmission side-frame guards, bottom guards, standard tires, full fuel tank, and 79-kg (175 lb.) operator. This information is affected by changes in tires, ballast, and different attachments, and assumes no tire deflection per the standard ISO 14397-1 section 5.



**Specifications with Quick-Coupler and Hook-On Construction Fork**

**624K TOOL CARRIER**

▲ Tine Length . . . . .	1.22 m (48 in.)	1.52 m (60 in.)
Fork Frame . . . . .	1.52 m (60 in.)	2.29 m (90 in.)
▲▲ Overall Length . . . . .	8.02 m (26 ft. 4 in.)	8.33 m (27 ft. 4 in.)
Tipping Load, Straight (fork level, load centered and positioned at 50% tine length) . . . . .	9555 kg (21,065 lb.)	8946 kg (19,723 lb.)
Tipping Load, 40-Deg. Full Turn (fork level, load centered and positioned at 50% tine length). . . . .	8303 kg (18,305 lb.)	7755 kg (17,096 lb.)
Operating Weight. . . . .	14 955 kg (32,971 lb.)	15 094 kg (33,277 lb.)

Loader operating information is based on machine with identified linkage and standard equipment, ROPS cab, rear cast bumper/counterweight, transmission side-frame guards, bottom guards, standard tires, full fuel tank, and 79-kg (175 lb.) operator. This information is affected by changes in tires, ballast, and different attachments, and assumes no tire deflection per the standard ISO 14397-1 section 5.

**Adjustments to Operating Weights and Tipping Loads with Buckets**

Adjustments to operating weights and tipping loads are based on tool-carrier machine and pin-on 2.7-m<sup>3</sup> (3.5 cu. yd.) general-purpose bucket with bolt-on cutting edge, ROPS cab, rear cast bumper/counterweight, transmission side-frame guards, bottom guards, standard tires, full fuel tank, and 79-kg (175 lb.) operator\*

Add (+) or deduct (-) lb. (kg) as indicated for loaders with 3-piece rims and	Operating Weight	Tipping Load, Straight	Tipping Load, 40-Deg. Full Turn, SAE
20.5 R 25, 1 Star L-3 . . . . .	0 kg (0 lb.)	0 kg (0 lb.)	0 kg (0 lb.)
20.5 R 25, 1 Star L-2 . . . . .	- 148 kg (- 326 lb.)	- 103 kg (- 227 lb.)	- 91 kg (- 200 lb.)
20.5-25, 16 PR L-2 . . . . .	- 324 kg (- 714 lb.)	- 225 kg (- 496 lb.)	- 198 kg (- 437 lb.)
20.5-25, 16 PR L-3 . . . . .	- 228 kg (- 503 lb.)	- 158 kg (- 349 lb.)	- 139 kg (- 308 lb.)
600/65 R 25, 1 Star L-3T <sup>§</sup> . . . . .	+ 42 kg (+ 93 lb.)	+ 39 kg (+ 86 lb.)	+ 35 kg (+ 76 lb.)
28L-26 Logger <sup>†</sup> . . . . .	+ 406 kg (+ 895 lb.)	+ 292 kg (+ 643 lb.)	+ 257 kg (+ 567 lb.)
CaCl <sub>2</sub> in 20.5-25, L-3 rear tires . . . . .	+ 1166 kg (+ 2,571 lb.)	+ 1627 kg (+ 3,586 lb.)	+ 1433 kg (+ 3,159 lb.)

\*May change based on vehicle configuration, weight, or tire-pressure adjustments.

<sup>§</sup>CaCl<sub>2</sub> not recommended.

<sup>†</sup>Equipped with one-piece rims.

**Bucket Selection Guide\***

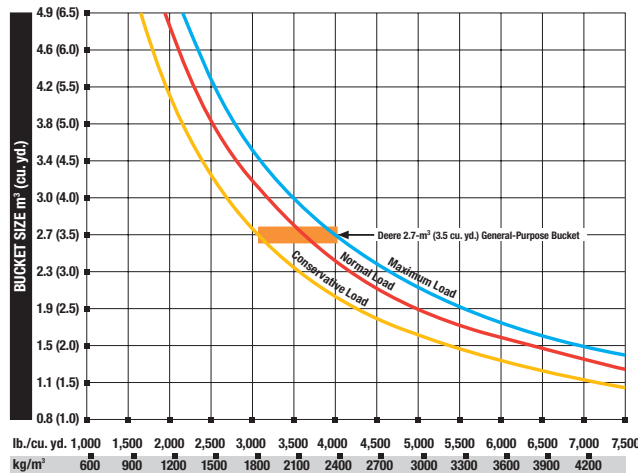

**624K TOOL-CARRIER LOADER WITH PIN-ON BUCKET**

LOOSE MATERIALS	kg/m <sup>3</sup>	lb./cu. yd.
Chips, pulpwood	288	486
Cinders (coal, ashes, clinkers)	673	1,134
Clay and gravel, dry	1602	2,700
Clay, compact, solid	1746	2,943
Clay, dry in lump loose	1009	1,701
Clay, excavated in water	1282	2,160
Coal, anthracite, broken, loose	865	1,458
Coal, bituminous, moderately wet	801	1,350
Earth, common loam, dry	1218	2,052
Earth, mud, packed	1843	3,105
Granite, broken	1538	2,592
Gypsum	2275	3,834
Limestone, coarse, sized	1570	2,646
Limestone, mixed sizes	1682	2,835
Limestone, pulverized or crushed	1362	2,295
Sand, damp	2083	3,510
Sand, dry	1762	2,970
Sand, voids, full of water	2083	3,510
Sandstone, quarried	1314	2,214
Shale, broken crushed	1362	2,295
Slag, furnace granulated	1955	3,294
Stone or gravel, 37.5 to 87.5-mm (1.5 to 3.5") size	1442	2,430
Stone or gravel, 18.75-mm (3/4") size	1602	2,700

\* This guide, representing bucket sizes not necessarily manufactured by Deere, will help you in selecting proper bucket size for material density, loader configuration, and operating conditions. Optimum bucket size is determined after adding or subtracting all tipping load changes due to optional equipment. The "conservative load" line on this guide is recommended when operating in conditions such as soft ground and unlevel surfaces. The "maximum load" condition on this guide is sometimes utilized when operating on firm ground and level surfaces.

# 444K / 524K / 544K / 624K LOADERS

**Key:** ● Standard equipment ▲ Optional equipment

## 444 524 544 624 Engine

- ● ● ● Wet-sleeve cylinder liners
- ● ● ● Automatic glow plugs for cold start
- ● ● ● Programmable auto-idle and auto-shutdown
- ● ● ● Selected idle adjustment from 900–1,250 rpm
- ● ● ● Starter protection
- ● ● ● Automatic derating for exceeded system temperatures
- ● ● ● Serpentine drive belt for automatic tensioner
- ● ● ● Under-hood prescreened air intake
- ● ● ● Dual-stage fuel filter and water separator
- ● ● ● 500-hour vertical spin-on oil filter
- ▲ ▲ ▲ ▲ Chrome exhaust stack
- ▲ ▲ ▲ ▲ Automatic ether starting aid (recommended for cold starts below –12 deg. C [10 deg. F])
- ▲ ▲ ▲ ▲ Engine-block heater (recommended for cold starts below –23 deg. C [–10 deg. F])
- ▲ ▲ ▲ ▲ Centrifugal engine air pre-cleaner

### Powertrain

- ● ● ● Programmable maximum high gear
- ● ● ● Clutch calibration engaged on monitor
- ● ● ● 2,000-hour vertical spin-on transmission filter
- ● ● ● Transmission fill tube and sight gauge
- ▲ ▲ ▲ ▲ Rear-axle disconnect
- ▲ ▲ ▲ ▲ Automatic differential lock
- ▲ ▲ ▲ ▲ Wheel-spin control

### Quad-Cool™ Cooling System

- ● ● ● Heavy-duty, trash-resistant radiator and high-ambient cooling package
- ● ● ● 2-side access to all coolers
- ● ● ● Isolated from engine compartment
- ● ● ● Engine radiator
- ● ● ● Integral engine oil cooler
- ● ● ● Hydraulic oil cooler (oil to air)
- ● ● ● Transmission oil cooler (oil to air)
- ● ● ● Charge air cooler (air to air)
- ● ● ● Coolant recovery tank
- ● ● ● Antifreeze, –37 deg. C (–34 deg. F)
- ● ● ● Cool-on-demand swing-out fan
- ● ● ● Enclosed fan safety guard
- ▲ ▲ ▲ ▲ Automatic reversing fan drive
- ▲ ▲ ▲ ▲ Axle coolers
- ▲ ▲ ▲ ▲ Harsh environmental coolers

### Hydraulics

- ● ● ● 2 function — joystick with F-N-R
- ● ● ● Automatic return to dig
- ● ● ● In-cab adjustable automatic return to dig (PowerLift™ only)
- ● ● ● In-cab adjustable automatic boom-height kickout/return to carry
- ● ● ● Reservoir with sight gauge and fill strainer
- ● ● ● Hydraulic diagnostic ports
- ● ● ● 4,000-hour in-tank filter
- ▲ ▲ ▲ ▲ 2 function — joystick with steering column F-N-R
- ▲ ▲ ▲ ▲ 2 function — 2-lever fingertip controls and steering column F-N-R
- ▲ ▲ ▲ ▲ 3 function — joystick with F-N-R and 3rd-function auxiliary lever
- ▲ ▲ ▲ ▲ 3 function — joystick with steering column F-N-R and 3rd-function auxiliary lever
- ▲ ▲ ▲ ▲ 3 function — 3-lever fingertip controls and steering column F-N-R
- ▲ ▲ ▲ ▲ 4 function — 4-lever fingertip controls and steering column F-N-R
- ▲ ▲ ▲ ▲ Ride control, automatic with monitor-adjustable speed settings

## 444 524 544 624 Hydraulics (continued)

- ▲ ▲ ▲ ▲ Hydraulic control system for quick-coupler locking pins

### Steering Systems

- ● ● ● Conventional steering wheel with spinner knob
- ▲ ▲ ▲ ▲ Joystick steering (including conventional steering column) with gearshift, F-N-R, and horn
- ▲ ▲ ▲ ▲ Secondary steering

### Electrical

- ● ● ● Solid-state electrical power-distribution system
- ● ● ● Lockable master electrical-disconnect switch
- ● ● ● Battery-terminal safety covers
- ● ● ● By-pass start safety cover at starter
- ● ● ● Pre-wired for beacon/strobe light
- ● ● ● Lights: Halogen driving lights with guards (2) / Front (4) and rear (2) work lights / Turn signals and flashers / LED stop- and taillights
- ● ● ● Horn, electric
- ● ● ● Reverse warning alarm
- ● ● ● Multi-function/multi-language LCD color monitor includes: Digital instruments — Analog display (hydraulic oil temperature, engine coolant temperature, transmission oil temperature, and engine oil pressure) / Digital display (engine rpm, transmission gear/direction indicator, hour meter, fuel level, speedometer, odometer, and outside temperature)
- ● ● ● Integrated cycle counter with 5 categories
- ● ● ● Indicator lights: Standard and selected options / Amber caution and red stop
- ● ● ● Operator-warning messages
- ● ● ● Built-in diagnostics: Diagnostic-code details / Sensor values / Calibrations / Individual circuit tester
- ● ● ● Menu display: Codes / Machine settings / Diagnostics / Monitor settings / Clock
- ▲ ▲ ▲ ▲ Heavy-duty LED turn signal and marker lights
- ▲ ▲ ▲ ▲ Electrical corrosion-prevention package
- ▲ ▲ ▲ ▲ AM/FM/WB radio
- ▲ ▲ ▲ ▲ AM/FM/WB radio with CD player
- ▲ ▲ ▲ ▲ 24- to 12-volt, 10-amp converter

### Operator's Station

- ● ● ● Canopy with ROPS/FOPS, isolation mounted
- ● ● ● Key-less start with multiple security modes
- ● ● ● Sealed-switch module with function indicators
- ● ● ● Seat with backrest extension, deep foam, vinyl cover, and adjustable air suspension
- ● ● ● Hydraulic controls integrated to seat
- ● ● ● Seat belt, 76 mm (3 in.), with retractor
- ● ● ● Cup holders (2)
- ● ● ● Lunch-box/cooler holder
- ● ● ● Dome and reading light
- ● ● ● Rubber floor mat
- ● ● ● Tilt steering column
- ● ● ● Operator's manual storage compartment
- ● ● ● Outside (2) and inside (1) rearview mirrors
- ● ● ● Left-side operator-station access
- ● ● ● Slip-resistant steps and ergonomic handholds
- ▲ ▲ ▲ ▲ Quiet cab with heater
- ▲ ▲ ▲ ▲ Quiet cab with air conditioning/heater
- ▲ ▲ ▲ ▲ Premium seat with high-wide back and headrest extension, heated, leather/fabric cover, and adjustable air suspension
- ▲ ▲ ▲ ▲ Seat with backrest extension, deep foam, fabric cover, and adjustable air suspension

See your John Deere dealer for further information.

## 444 524 544 624 Operator's Station (continued)

- ▲ ▲ ▲ ▲ Powered cab air pre-cleaner
- ▲ ▲ ▲ ▲ Large heated outside mirrors
- ▲ ▲ ▲ ▲ Beacon bracket
- ▲ ▲ ▲ ▲ Rear camera and radar object-detection system
- ▲ ▲ ▲ ▲ Embedded payload scale
- ▲ ▲ ▲ ▲ Fire extinguisher
- ▲ ▲ ▲ ▲ ROPS canopy rear window

### Loader Linkage

- ● ● ● Z-bar loader linkage
- ▲ ▲ ▲ ▲ PowerLift linkage for visibility and parallel-lift
- ▲ ▲ ▲ ▲ High-lift Z-bar loader linkage
- ▲ ▲ ▲ ▲ Tool-carrier linkage for parallel-lift

### Buckets and Attachments

- ▲ ▲ ▲ ▲ Full line of Deere pin-on buckets
- ▲ ▲ ▲ ▲ Worksite Pro™ hydraulic coupler which accepts JRB-pattern attachments
- ▲ ▲ ▲ ▲ Hi-vis hydraulic coupler which accepts Euro-pattern attachments (Volvo)
- ▲ ▲ ▲ ▲ Full line of Deere hook-on buckets and forks
- ▲ ▲ ▲ ▲ Bolt-on fork frame guard

### Overall Vehicle

- ▲ ▲ ▲ ● JDLink™ Ultimate wireless communication system (available only in U.S. and Canada)\*
- ● ● ● NeverGrease™ rear-axle oscillation
- ● ● ● NeverGrease steering-cylinder joints
- ● ● ● Front and rear tie-downs
- ● ● ● Fenders, front
- ● ● ● Rear hitch with locking pin
- ● ● ● Articulation locking bar
- ● ● ● Loader boom service locking bar
- ● ● ● 40-degree steering articulation to each side with rubber-cushion stops on frame
- ● ● ● Vandal protection with lockable engine enclosures, right counterweight storage, battery box, and filler access for radiator/fuel/hydraulic/transmission
- ● ● ● Service steps and handholds
- ● ● ● Storage compartment
- ● ● ● Fuel-tank fill strainer
- ● ● ● Heavy-duty fuel-tank guard
- ● ● ● Ground-level fueling
- ● ● ● 17.5R25 L3 radial tires on 3-piece rims
- ▲ ● ● ● 20.5R25 L3 radial tires on 3-piece rims
- ▲ ▲ ▲ ▲ Waste handler (Z-bar and High-Lift)
- ▲ ▲ ▲ ▲ NeverGrease linkage (Z-bar and High-Lift)
- ▲ ▲ ▲ ▲ Level 1 sound package
- ▲ ▲ ▲ ▲ Level 2 sound package
- ▲ ▲ ▲ ▲ Environmental drains and sample ports
- ▲ ▲ ▲ ▲ Quick fluid service (engine, transmission, hydraulic oils, and engine coolant)
- ▲ ▲ ▲ ▲ Fenders, full-coverage, front
- ▲ ▲ ▲ ▲ Fenders, full-coverage, front and rear
- ▲ ▲ ▲ ▲ Close-mounted steps
- ▲ ▲ ▲ ▲ Rear cast bumper/counterweight with rear hitch and locking pin
- ▲ ▲ ▲ ▲ Less wheels and tires with 8-deg. axle stops
- ▲ ▲ ▲ ▲ Rims less tires
- ▲ ▲ ▲ ▲ Transmission side-frame guards
- ▲ ▲ ▲ ▲ Bottom guards, front frame and transmission
- ▲ ▲ ▲ ▲ Lift eyes
- ▲ ▲ ▲ ▲ License-plate bracket and light
- ▲ ▲ ▲ ▲ Special guarding for waste and forestry applications

\*Standard on 624K cabs / optional on 624K canopies.



JOHN DEERE

Net engine power is with standard equipment including air cleaner, exhaust system, alternator, and cooling fan at test conditions per ISO9249. No derating is required up to 3050-m (10,000 ft.) altitude for the 444K, 524K, 544K, and 624K.

Specifications and design subject to change without notice. Specifications are in accordance with ISO standards. Except where otherwise noted, these specifications are based on units with applicable linkage and standard equipment, ROPS cab, rear cast bumper/counterweight, transmission side-frame guards, bottom guards, standard tires, full fuel tank, and 79-kg (175 lb.) operator.



## Free Manuals Download Website

<http://myh66.com>

<http://usermanuals.us>

<http://www.somanuals.com>

<http://www.4manuals.cc>

<http://www.manual-lib.com>

<http://www.404manual.com>

<http://www.luxmanual.com>

<http://aubethermostatmanual.com>

Golf course search by state

<http://golfingnear.com>

Email search by domain

<http://emailbydomain.com>

Auto manuals search

<http://auto.somanuals.com>

TV manuals search

<http://tv.somanuals.com>