

# SKIDDERS

GRAPPLE 548G-III 648G-III 748G-III CABLE 540G-III 640G-III

FULL TREE SYSTEM ▶

HARVESTING

TRANSPORTING

LOADING ▼





# THE PERFECT SKIDDER FOR YOUR IMPERFECT WORKING CONDITIONS.

## FULL TREE SYSTEM

HARVESTING

TRANSPORTING

LOADING



Full Tree System—No one offers the extensive product line, dealer network and tough, purpose-built machines like John Deere.

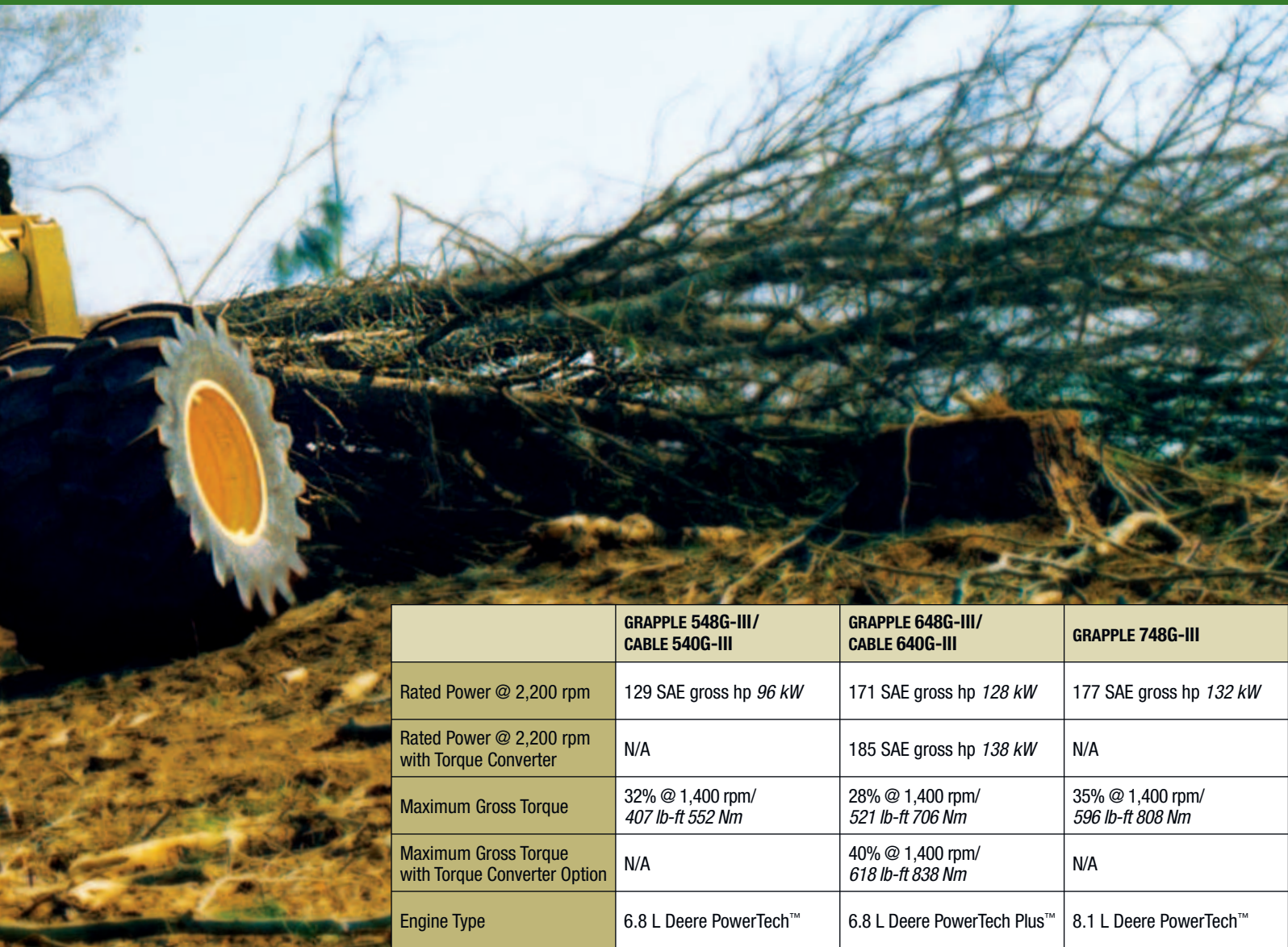

	<b>GRAPPLE 548G-III/ CABLE 540G-III</b>	<b>GRAPPLE 648G-III/ CABLE 640G-III</b>	<b>GRAPPLE 748G-III</b>
Rated Power @ 2,200 rpm	129 SAE gross hp <i>96 kW</i>	171 SAE gross hp <i>128 kW</i>	177 SAE gross hp <i>132 kW</i>
Rated Power @ 2,200 rpm with Torque Converter	N/A	185 SAE gross hp <i>138 kW</i>	N/A
Maximum Gross Torque	32% @ 1,400 rpm/ <i>407 lb-ft 552 Nm</i>	28% @ 1,400 rpm/ <i>521 lb-ft 706 Nm</i>	35% @ 1,400 rpm/ <i>596 lb-ft 808 Nm</i>
Maximum Gross Torque with Torque Converter Option	N/A	40% @ 1,400 rpm/ <i>618 lb-ft 838 Nm</i>	N/A
Engine Type	6.8 L Deere PowerTech™	6.8 L Deere PowerTech Plus™	8.1 L Deere PowerTech™

## No matter what kind of terrain you work, there's a John Deere G-III Series Skidder that can be perfectly matched to your exact needs.

You know what you need out of your skidder. We can give it to you with the widest range of models and options in the industry. Choose the size, power, and options that best suit your job needs.

With a selection of engines, transmissions, axles, grapples, winches and cab comforts, you can build the perfect skidder.



Standard decking blade has a replaceable, weld-on cutting edge of high-carbon material for longer life.

A heavy-duty blade (optional on the 648G-III, standard on the 748G-III) is wider at 9-ft 8-in (2,95 m) with a heavier weld-on cutting edge for more tire protection and improved weight distribution.

## GRAPPLE SKIDDERS IMPRESS THE GUYS BACK AT THE LANDING.

You can count on John Deere Grapples to pick up a load the first try.

The innovative G-III Series Grapples are designed with two hydraulic cylinders, one for each tong, so they adjust to each load with a secure grip. Closed-center, load-sensing hydraulics maintain constant pressure on the tongs from start to finish. Box construction with three internal ribs on each tong makes them stronger without adding weight.

The single-function arch simply lowers and raises the grapple head. It's most productive working where it can pick up tightly bunched piles in a single pass. Dual-arch geometry uses four cylinders to reach out as well as lift. It pulls the load over the rear for the best weight distribution and heavy load control over longer hauls.

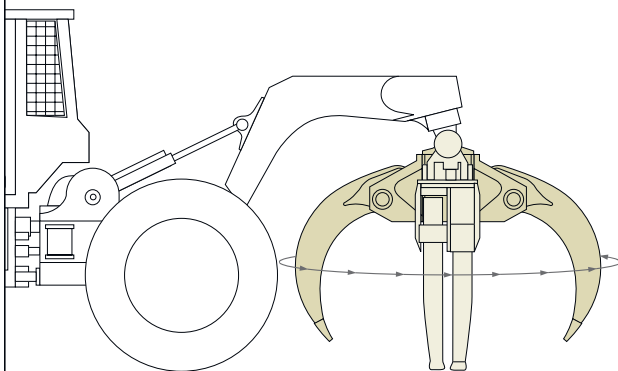

Choose from four single-function grapples or three dual-function grapple versions.

A high torque motor drives the grapple through 360-degree continuous rotation.

John Deere winches provide the power and confidence you need to skid big loads.



## CABLE SKIDDERS MAKE THE MOST OF EVERY LOAD.

G-III Series Cable Skidders have the power to skid big loads.

John Deere winches give you the power and reliability you need. They are easy to operate with a single lever, and feature powerful line pull, sealed wet-disc clutches, and spring-applied, hydraulically activated brakes for extreme durability.

The rear assembly is built forest-tough to withstand the heavy buffering they endure. The adjustable fairlead, heavy butt pan, see-through ramguard screen, and strong fenders protect the tires, rear frame, winch, and more importantly—the operator.



The fenders are shaped to guide butts into the best position for load control during skidding.

# LET'S KICK THE TIRES.

SKIDDERS

GRAPPLE 548G-III 648G-III 748G-III CABLE 540G-III 640G-III

The standard 4000 winch on cable skidders boosts a bare drum line pull up to 47,697 lbf (212 kN), while the optional 6000, only available on the 640G-III, pulls a massive 50,517 lbf (225 kN). They are both easily operated with a single lever and feature sealed, wet-disc clutches and spring-applied, hydraulically activated brakes for extreme durability.

6.8 L and 8.1 L Deere engines feature high torque rise, heavy-duty engine blocks, proven durability and fuel efficiency.

Industry-leading Deere diesel engines feature Powershift transmissions, with seven forward and six reverse gears, which are controlled with a bump shifter for ease of operation.



Industry-leading cab design utilizes isolation mounts for reduced noise, vibration, and driver fatigue. Operator comforts include a seat that swivels up to 30 degrees, ergonomically located controls, a tilt/telescopic steering wheel, and climate control for all-season comfort.

Grapples are designed with two hydraulic cylinders that adjust to each load. Closed-center, load-sensing hydraulics maintain constant pressure on the tongs. Three internal ribs on each tong make them stronger without adding weight, and tong tips are constructed of wear-resistant cast steel for a reliable grip.

Inboard planetary axles feature wet disc brakes sealed and immersed in cooling oil bath. They are self-equalizing and self-adjusting to decrease wear with on-the-fly diff locks.

## THE 600 SERIES SKIDDERS RUN CLEAN WITHOUT COMPROMISE.

The muscle behind the 600 Series Skidders is the powerful PowerTech Plus™ 6.8 L engine that runs clean without sacrificing power.

All John Deere skidder engines meet EPA and CARB emission non-road regulations, while maintaining the legendary John Deere power.

Exhaust gas recirculation (EGR) cools and mixes measured amounts of exhaust gas with incoming fresh air to lower peak combustion temperatures and reduce emissions. And the engine's four-valve design, with high-pressure common rail fuel injection, provides greater low-speed torque and better transient response.

The 600 Series Skidders feature an enhanced cooling system with a new, more efficient sucker fan design, which draws air in the front, through the cooling package and out the sides. The hydraulically driven cooling fan is temperature controlled, so it runs only as needed, minimizing horsepower use and drag. The fan is fully reversible to automatically blow debris off the grill screen, optimizing air flow.

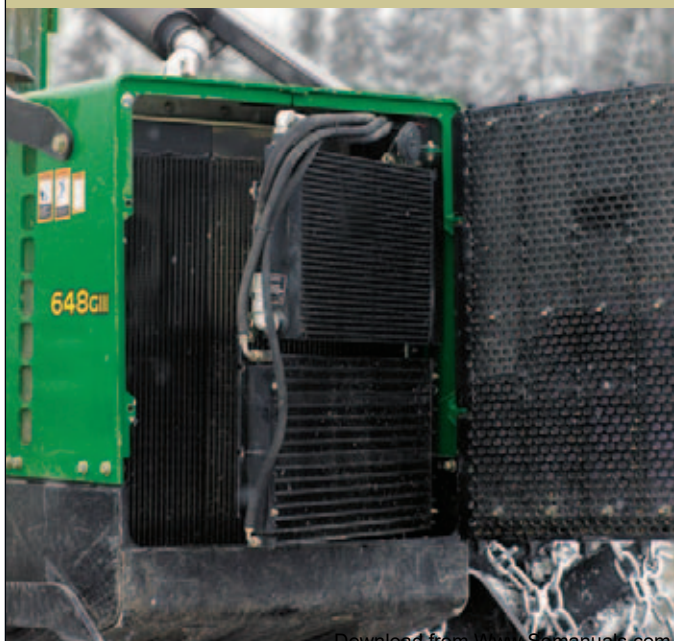

The hydraulic reversible fan maximizes debris management, and productivity, by automatically blowing off the screen.

The new sucker fan design on the cooling package pulls air in through the front and out the sides.

The hinged door optimizes serviceability with easy access to the cooling package.





### Southern Thinning Special

Designed specifically to make first thinnings more profitable, the optional 648G-III Single Arch Grapple Skidder can pull larger loads each turn to increase the amount of wood to the landing every shift. It has a large 123-in (312 cm) grapple and an extended 145-in (368 cm) wheelbase for better balance and stability to handle larger loads. The wider stance improves traction when reversing uphill or backing up to a gate delimeter.

- New bulkhead fittings in the cab improve the electrical system's reliability and simplifies serviceability.
- The dual-arch 648G-III features a new 125-inch grapple, with 12.5 square feet of carrying capacity, a 6.8% increase over the previous model. And added wear plating to the tongs improves its durability.
- The fuel tank on the single- and dual-arch 648G-III Skidders has been increased by 10 gallons, increasing the machine's productivity by minimizing fuel-ups.
- Torque converter transmission, with six forward and three reverse gears, available in the 648G-III Grapple Skidder and 640G-III Cable Skidder.

# MORE POWER. MORE COMFORT. MORE DONE.

The G-III Series Skidder engines deliver high torque-on-demand power and best-in-class cabs that will keep your operator happy and your landing busy.



All John Deere engines use an advanced, electronically controlled fuel injection system that produces more torque for quick turnaround and faster cycles. The common rail fuel injection system controls the big power bulge programmed into the torque curve. Power automatically adjusts as the load increases, optimizing performance and productivity.

The quiet, isolation-mounted cabin on the G-III Series Skidders will keep the operator working effortlessly without sacrificing control or production efficiency. The seat is fully adjustable for individual height and weight, and it swivels so the operator doesn't have to. The steering wheel with spinner knob is adjustable as well. And the soft-touch levers are positioned to give easy control with the least amount of effort.

- The standard cab is isolation-mounted for quiet operation, with tinted front windshield, sun visor, and heavy screens to secure the sides and back.
- The optional cab is fully enclosed with polycarbonate windows on all openings and screens on the door windows only. This well-sealed cab keeps dust out and helps the air conditioning, venting, and heating systems operate at peak efficiency.
- Optional AM/FM stereo, located in the contoured headliner with remote speakers, has a CD or cassette option.
- An electronic hand throttle option with three pre-set speeds lets the operator free up his throttle pedal foot.
- The little things that mean a lot—a dome light, storage under the armrest with cell phone hookup, a beverage holder, door bins, and easy-to-read gauges, indicators and switches.

- Controls for heating, venting, air conditioning, and windshield wipers are handy without obstructing visibility.
- A quick glance tells you engine temperature, transmission oil temperature, and fuel level. The select button to the left calls up digital readouts for hour meter, gear selection, battery voltage, engine rpm, and hydraulic oil temperature, along with fault codes for the engine and transmission. The warning indicators across the bottom are accompanied by audible alarm beeps, either critical for immediate shut-down or cautionary to warn of less critical malfunction.
- For really soft going, steep slopes or severe ground, the smooth, steady traction of the torque converter powershift can make all the difference.



*Some features differ from model to model.*

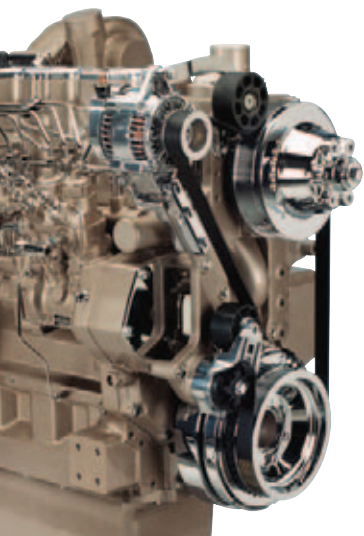

Fast maneuvering with 90-degree stop-to-stop articulation and differential locks front and rear.

John Deere turbocharged engines have the steep torque rise for easier load starting, better low-speed driveability and superior lugging power.

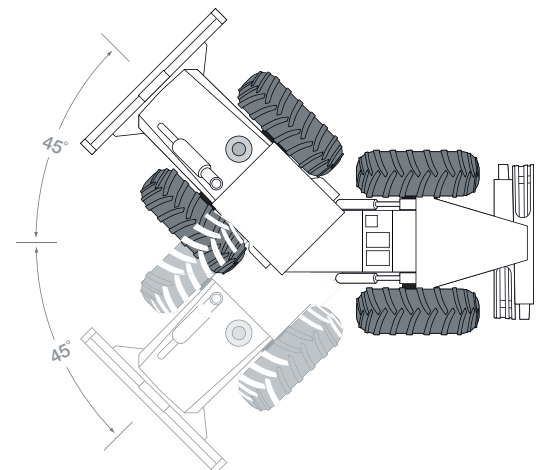

The hydraulic wet-disc brakes are completely sealed and immersed in an oil cooling bath. They are self-equalizing and self-adjusting for wear, extending their service intervals.



## AS RELIABLE AS THE WORKDAY IS LONG.

Building reliability into the transmissions and axles sets the G-III Series Skidders apart from the competition load after load.

Not only are John Deere transmissions built to work efficiently, but the internal oil flow for the bearing to the front housing gives a more consistent flow, eliminating external lines to avoid damage and extending the transmission's life cycle. The engines have heavy-duty blocks, high-capacity oil and water pumps, and hardened, replaceable wet cylinder liners that make them as durable as they are productive.

With a choice of tires and axles, you can build a skidder to your working conditions. The powerful, dependable driveline gives you the rim pull to skid heavy loads shift after shift. It all adds up to a skidder you can count on no matter what the terrain.



Direct drive or torque converter powershift—choose the one that's right for your job. The standard direct drive powershift transmission puts the most power to the axles on mostly firm ground and for short-to-medium skidding distances.



The 100-inch (254 cm) SWEDA axles, for flotation tires or duals, has a massive housing, large axle and flange, plus its own dipstick for fast oil check.

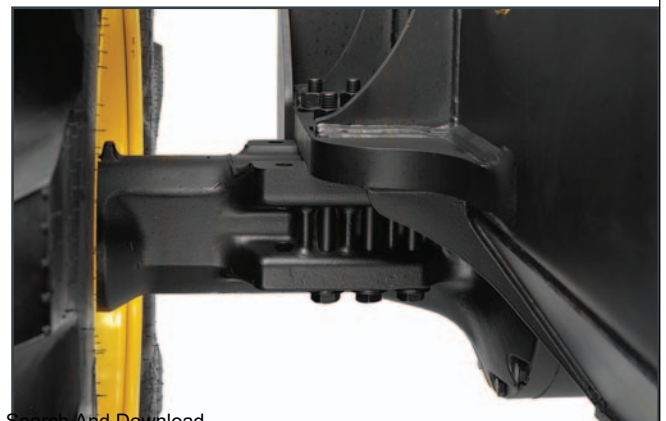



## STRETCH YOUR DAILY OPERATING COSTS FURTHER.

When it comes to servicing, it's good to know your skidder will make it as quick and painless as possible.

There's nothing to compare with the simple service access these skidders offer. The cab can be released and hydraulically tilted in a few minutes, providing unrestricted access to all critical components. Daily servicing points are easy to get at as well, making routine maintenance less of a chore.



- Quick-release fuel filters and separators, spin-on oil filters, and oil drain shut-off for spill-free oil changes make daily maintenance a snap.
- The panel door behind the cab can be lowered for easy access to HVAC's filters, evaporators, blower motor, and optional precleaner.
- Extended Coverage Warranty lets you custom fit coverage to your specific needs, giving you a fixed cost for machine repairs over a given period of time. Whether you work in a severe-service operation or just want to spread the risk of doing business, Extended Coverage Warranty is a great way to protect your cash flow.



Rest assured that your purpose-built John Deere Forestry equipment is supported by the most extensive dealer network in the industry and unsurpassed parts availability. That's our promise.

## ENGINE

	548G-III	648G-III	748G-III
Type	John Deere 6068T, 6-cylinder, meets EPA and CARB emission non-road regulations, with altitude compensating spark-arresting turbocharger	John Deere 6068H, 6-cylinder, meets EPA and CARB emission non-road regulations, with altitude compensating spark-arresting turbocharger	John Deere 6081H, 6-cylinder, meets EPA and CARB emission non-road regulations, with altitude compensating spark-arresting turbocharger
Rated Power @ 2,200 rpm	129 SAE gross hp <i>96 kW</i>	171 SAE gross hp <i>128 kW</i>	177 SAE gross hp <i>132 kW</i>
With Torque-Converter Option		185 SAE gross hp <i>138 kW</i>	
Displacement	414 cu-in <i>6,8 L</i>	414 cu-in <i>6,8 L</i>	494 cu-in <i>8,1 L</i>
Maximum Gross Torque	32% @ 1,400 rpm / <i>407 lb-ft 552 Nm</i>	28% @ 1,400 rpm / <i>521 lb-ft 706 Nm</i>	35% @ 1,400 rpm / <i>596 lb-ft 808 Nm</i>
With Torque-Converter Option		40% @ 1,400 rpm / <i>618 lb-ft 838 Nm</i>	
Air Cleaner	Dual stage with safety element and dust unloader valve	Dual stage with safety element and dust unloader valve	Dual stage with safety element and dust unloader valve
Cooling System	Heavy-duty radiator with in-line core coolant recovery reservoir	Heavy-duty radiator with in-line core coolant recovery reservoir	Heavy-duty radiator with in-line core coolant recovery reservoir
Cooling Fan	Blower	Sucker	Blower
Lubrication	Pressure system with oil cooler	Pressure system with oil cooler	Pressure system with oil cooler
Oil Filter	Vertically mounted spin-on	Vertically mounted spin-on	Vertically mounted spin-on
Electrical System	12 volt with 120-amp alternator	12 volt with 120-amp alternator	12 volt with 120-amp alternator
Battery (two 12 volt)	Reserve capacity: 360 min, 1,850 CCA	Reserve capacity: 360 min, 1,850 CCA	Reserve capacity: 360 min, 1,850 CCA

## TRANSMISSION

Type	Direct-drive power shift*	Direct-drive power shift*	Direct-drive power shift*
Oil Filtration	10 micron pressure side with bypass	10 micron pressure side with bypass	10 micron pressure side with bypass

\*Power shift with torque converter optional on 648G-III only

## AXLES

Final Drives	Heavy-duty planetary, mounted inboard	Heavy-duty planetary, mounted inboard	Heavy-duty planetary, mounted inboard
Differentials	Hydraulic locking, operated on the go	Hydraulic locking, operated on the go	Hydraulic locking, operated on the go
Front Axle Oscillation	30 degrees, stop to stop	30 degrees, stop to stop	30 degrees, stop to stop

## BRAKES

Service Brakes	Long-life, inboard-mounted wet disc oil cooled, self-adjusting and self-equalizing front and rear axles
Parking Brake	Automatically spring-applied, hydraulically released, sealed and lubricated, wet multi-disc, integrally mounted in transmission

## STEERING

Frame Articulation	90 degrees total, stop to stop	90 degrees total, stop to stop	90 degrees total, stop to stop
Steering Wheel With Orbitrol™ Valve			

## POWER TRAIN PERFORMANCE

	548G-III		648G-III DIRECT DRIVE		748G-III	
	with 28L-26 tires		with 30.5-32 tires		with 30.5-32 tires	
No Tire Slip	Maximum Speed	Maximum Drawbar	Maximum Speed	Maximum Drawbar	Maximum Speed	Maximum Drawbar
	@ 2,200 rpm	@ peak torque	@ 2,200 rpm	@ peak torque	@ 2,200 rpm	@ peak torque
<b>Forward</b>						
Gear 1	1.4 mph 2,3 km/hr	31,143 lb 139 kN	1.7 mph 2,7 km/hr	36,139 lb 161 kN	1.7 mph 2,7 km/hr	37,812 lb 168 kN
Gear 2	1.9 mph 3,0 km/hr	23,465 lb 104 kN	2.2 mph 3,5 km/hr	27,229 lb 121 kN	2.2 mph 3,5 km/hr	28,490 lb 127 kN
Gear 3	2.5 mph 4,0 km/hr	17,628 lb 78 kN	2.9 mph 4,7 km/hr	20,479 lb 91 kN	2.9 mph 4,7 km/hr	21,739 lb 97 kN
Gear 4	3.3 mph 5,3 km/hr	13,280 lb 59 kN	3.9 mph 6,3 km/hr	15,428 lb 69 kN	3.9 mph 6,3 km/hr	16,377 lb 73 kN
Gear 5	4.4 mph 7,1 km/hr	9,950 lb 44 kN	5.2 mph 8,4 km/hr	11,559 lb 51 kN	5.8 mph 9,3 km/hr	11,979 lb 53 kN
Gear 6	5.9 mph 9,5 km/hr	7,482 lb 33 kN	6.9 mph 11,1 km/hr	8,692 lb 39 kN	7.7 mph 12,4 km/hr	9,008 lb 40 kN
Gear 7	8.7 mph 14,0 km/hr	5,053 lb 22 kN	10.2 mph 16,4 km/hr	5,864 lb 26 kN	11.4 mph 18,3 km/hr	6,084 lb 27 kN
Gear 8	11.6 mph 18,7 km/hr	3,792 lb 17 kN	13.6 mph 21,9 km/hr	4,400 lb 19 kN	15.2 mph 24,5 km/hr	4,565 lb 20 kN
<b>Reverse</b>						
Gear 1	1.4 mph 2,3 km/hr	31,143 lb 139 kN	1.7 mph 2,7 km/hr	36,139 lb 161 kN	1.7 mph 2,7 km/hr	37,812 lb 168 kN
Gear 2	1.9 mph 3,0 km/hr	23,465 lb 104 kN	2.2 mph 3,5 km/hr	27,229 lb 121 kN	2.2 mph 3,5 km/hr	28,490 lb 127 kN
Gear 3	2.5 mph 4,0 km/hr	17,628 lb 78 kN	2.9 mph 4,7 km/hr	20,479 lb 91 kN	2.9 mph 4,7 km/hr	21,374 lb 95 kN
Gear 4	3.3 mph 5,3 km/hr	13,280 lb 59 kN	3.9 mph 6,3 km/hr	15,428 lb 69 kN	3.9 mph 6,3 km/hr	16,124 lb 72 kN
Gear 5	4.4 mph 7,1 km/hr	9,950 lb 44 kN	5.2 mph 8,4 km/hr	11,559 lb 51 kN	5.2 mph 8,4 km/hr	12,081 lb 54 kN
Gear 6	5.9 mph 9,5 km/hr	7,482 lb 33 kN	6.9 mph 11,1 km/hr	8,692 lb 36 kN	6.9 mph 11,1 km/hr	9,084 lb 40 kN
Gear 7	8.7 mph 14,0 km/hr	5,053 lb 22 kN	10.2 mph 16,4 km/hr	5,864 lb 26 kN	10.2 mph 16,4 km/hr	6,136 lb 27 kN

™Orbitrol is a registered trademark of Eaton Corp.



**HYDRAULIC SYSTEM****548G-III****648G-III DIRECT DRIVE****748G-III**

Pump.....	Variable-displacement axial piston .....		Variable-displacement axial piston.....		Variable-displacement axial piston	
Maximum Rated Flow .....	27 gpm 102 L/min @ 2,200 rpm .....		42 gpm 159 L/min @ 2,200 rpm .....		42 gpm 159 L/min @ 2,200 rpm	
Pressure .....	3,000 psi 20 684 kPa.....		3,000 psi 20 684 kPa.....		3,000 psi 20 684 kPa	
Oil Filtration .....	One 10 micron return oil with bypass .....		One 10 micron return oil with bypass.....		One 10 micron return oil with bypass	

**WINCH (OPTIONAL)**

Type .....	Sealed, wet multi-disc clutch and brake .....		Sealed, wet multi-disc clutch and brake.....		Sealed, wet multi-disc clutch and brake	
	pressurized lubrication single lever control		pressurized lubrication single lever control		pressurized lubrication single lever control	
Cable Capacity	4000 (8-in drum)	4000 (10-in drum)	4000 (8-in drum)	4000 (10-in drum)	4000 (8-in drum)	
0.625-in 15,8 mm cable .....	254-ft 77,4 m.....	199-ft 60,6 m.....	254-ft 77,4 m.....	199-ft 60,6 m.....	254-ft 77,4 m	
0.75-in 19,1 mm cable .....	179-ft 54,6 m.....	141-ft 43 m.....	179-ft 54,6 m.....	141-ft 43 m.....	179-ft 54,6 m	
0.875-in 22,2 mm cable .....	129-ft 39,3 m.....	101-ft 30,8 m.....	129-ft 39,3 m.....	101-ft 30,8 m.....	129-ft 39,3 m	
1-in 25,4 mm cable .....	100-ft 30,5 m.....	78-ft 23,8 m.....	100-ft 30,5 m.....	78-ft 23,8 m.....	100-ft 30,5 m	
0.625-in 15,8 mm cable	Bare Drum	Full Drum	Bare Drum	Full Drum	Bare Drum	Full Drum
4000 (8-in drum high speed) .....	30,068 lb 134 kN.....	18,150 lb 81 kN.....	37,296 lb 166 kN.....	22,377 lb 100 kN.....	43,313 lb 193 kN.....	25,988 lb 116 kN
4000 (8-in drum standard speed).....	35,029 lb 156 kN.....	21,145 lb 94 kN.....	43,449 lb 193 kN.....	26,069 lb 116 kN.....	50,458 lb 224 kN.....	30,275 lb 135 kN
4000 (10-in drum high speed) .....	28,435 lb 127 kN.....	21,145 lb 94 kN.....	35,270 lb 157 kN.....	26,069 lb 116 kN.....		
Line Speed @ 2,200 rpm,						
0.625-in 15,8 mm cable	Bare Drum	Full Drum	Bare Drum	Full Drum	Bare Drum	Full Drum
4000 (8-in drum high speed) .....	142 fpm .....	236 fpm .....	142 fpm.....	236 fpm.....	142 fpm .....	236 fpm
	43,2 m/min	72,0 m/min	43,2 m/min	72,0 m/min	43,2 m/min	72,0 m/min
4000 (8-in drum standard speed)	122 fpm	203 fpm	122 fpm	203 fpm	122 fpm	203 fpm
	37,1 m/min	61,8 m/min	37,1 m/min	61,8 m/min	37,1 m/min	61,8 m/min
4000 (10-in drum high speed) .....	150 fpm .....	203 fpm .....	150 fpm.....	203 fpm.....	150 fpm .....	203 fpm
	45,7 m/min	61,8 m/min	45,7 m/min	61,8 m/min	45,7 m/min	61,8 m/min

**GROUND PRESSURE DATA [BASED ON 3-INCH GROUND PENETRATION]**

Tires	Single Function	Single Function Short Frame	Dual Function	Dual Function
23.1-26 .....	8.4 psi 57,9 kPa			
28L-26 .....	7.0 psi 48,3 kPa.....	6.0 psi 41,4 kPa		
24.5-32 .....	7.4 psi 51,0 kPa.....	8.6 psi 60,3 kPa.....	8.9 psi 61,4 kPa .....	9.5 psi 65,5 kPa
30.5-32 .....	6.2 psi 42,7 kPa.....	7.2 psi 49,9 kPa.....	7.4 psi 51,0 kPa .....	7.9 psi 54,5 kPa
67/34-25 or 26 .....	6.3 psi 43,4 kPa.....	7.3 psi 50,3 kPa.....	7.5 psi 51,7 kPa .....	8.0 psi 55,2 kPa
66/43-25 or 26 .....	5.6 psi 38,6 kPa.....	6.4 psi 44,1 kPa.....	6.5 psi 44,8 kPa .....	7.0 psi 48,3 kPa
68/50-32 .....			5.0 psi 34,5 kPa .....	5.3 psi 36,5 kPa
73/44-32 .....				6.0 psi 41,4 kPa
30.5/24.5 Duals .....				5.6 psi 38,6 kPa

**CAPACITIES [U.S.]**

	Single Function	Single Function Short Frame	Dual Function	Dual Function
Fuel Tank.....	50 gal 189 L.....	73 gal 276,3 L.....	83 gal 313 L.....	83 gal 313 L
Cooling System.....	26 qt 24,6 L.....	36 qt 34 L.....	36 qt 34 L.....	30 qt 28,4 L
Engine Lubrication, Including Filter .....	20 qt 18,9 L.....	20 qt 18,9 L.....	20 qt 18,9 L.....	25 qt 23,7 L
Transmission .....	7.75 gal 29,3 L.....	7.75 gal 29,3 L.....	7.75 gal 29,3 L.....	7.75 gal 29,3 L
Differentials				
Front.....	4.5 gal 17 L.....	4.5 gal 17 L.....	7.5 gal 28,4 L.....	7.5 gal 28,4 L
Rear.....	4.5 gal 17 L.....	7.5 gal 28,4 L.....	7.5 gal 28,4 L.....	7.5 gal 28,4 L
Winch .....	9.3 gal 35,2 L.....	9.3 gal 35,2 L.....	9.3 gal 35,2 L.....	9.3 gal 35,2 L
Hydraulic Reservoir.....	8 gal 30,3 L.....	14.3 gal 54 L.....	14.3 gal 54 L.....	11 gal 41,6 L

**OPERATING WEIGHTS**

	Single Function	Single Function Short Frame	Dual Function	Dual Function
Standard Equipment .....	23,690 lb.....	30,655 lb.....	31,975 lb.....	34,310 lb
	10 768 kg	13 934 kg	14 534 kg	15 595 kg
	(23.1x26 tires)	(30.5x32 tires)	(30.5x32 tires)	(30.5x32 tires)

## JOHN DEERE G-III SERIES GRAPPLE SKIDDERS

DIMENSIONS	548G-III	648G-III DIRECT DRIVE	648G-III TORQUE CONVERTER	748G-III
Tire Size.....	28L-26, 14 PR LS2.....	28L-26, 14 PR LS2.....	30.5-32, 16 PR LS2.....	30.5-32, 16 PR LS2.....
A Overall Height*.....	9-ft 10.5-in 3,01 m.....	9-ft 11-in 3,03 m.....	10-ft 3.1-in 3,13 m.....	10-ft 3.1-in 3,13 m.....
B Maximum Blade Lift Above Ground.....	3-ft 11.6-in 1,21 m.....	4-ft 3.5-in 1,31 m.....	4-ft 11-in 1,50 m.....	4-ft 11-in 1,50 m.....
C Maximum Blade Dig Below Ground.....	11.3-in 288 mm.....	14.5-in 367 mm.....	14.2-in 360 mm.....	14.2-in 360 mm.....
C-1 Dozer Blade Width.....	7-ft 2-in 2 184 mm.....	7-ft 2-in 2 184 mm.....	9-ft 8-in 2 964 mm.....	9-ft 8-in 2 964 mm.....
Optional.....		9-ft 8-in 2 964 mm.....	9-ft 8-in 2 964 mm.....	
D Front Axle To Front Of Machine.....	4-ft 11.3-in 1 507 mm.....	5-ft 6.3-in 1 685 mm.....	5-ft 10-in 1 777 mm.....	5-ft 10-in 1 777 mm.....
E Front Axle To Blade Cutting Edge Arc.....	6-ft 11.2-in 2 112 mm.....	7-ft 6.2-in 2 292 mm.....	8-ft 1.4-in 2 474 mm.....	8-ft 1.4-in 2 474 mm.....
F Front Axle To Articulation Joint.....	5-ft 2-in 1 575 mm.....	5-ft 8-in 1 727 mm.....	5-ft 10-in 1 778 mm.....	5-ft 8-in 1 727 mm.....
G Wheelbase.....	9-ft 7-in 2 920 mm.....	11-ft 3-in 3 430 mm†.....	11-ft 5-in 3 481 mm†.....	12-ft 1-in 3 680 mm.....

\*Add 6.3-in 160 mm when equipped with water tank  
 †For Long Frame Single Arch and for Dual-function machines add 10-in 254 mm

## GRAPPLE

	Single Function	Single Function	Dual Function	Dual Function
H Height Of Grapple From Ground Level.....	34-in 864 mm	31-in 908 mm	4-ft 6-in 1 376 mm	4-ft 4.4-in 1 331 mm
I Reach Of Grapple At Ground Level.....	6-ft 5.6-in 1 970 mm	7-ft 4.3-in 2 243 mm	5-ft 1-in 1 536 mm	5-ft 1-in 1 547 mm
J Reach Of Grapple At Full Reach.....	7-ft 1-in 2 158 mm	7-ft 11.8-in 2 433 mm	9-ft 8.9-in 2 968 mm	9-ft 8.9-in 2 968 mm
K Maximum Height Of Boom.....	9-ft 10-in 2 991 mm	10-ft 6-in 3 195 mm	12-ft 1-in 3 680 mm	12-ft 4.9-in 3 781 mm
L Below Ground Reach Of Grapple At Full Reach.....	34-in 872 mm	37-in 942 mm	42.2-in 1 072 mm	44-in 1 117 mm
M Overall Length.....	20-ft 9-in 6 330 mm	23-ft 8.6-in† 7 230 mm	25-ft 7.6-in 7 814 mm	25-ft 5.6-in 7 763 mm

†For Long Frame Single Arch machine, add 10-in 254 mm

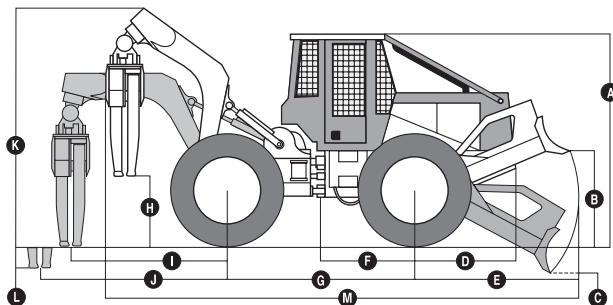

548G-III / 648G-III / 748G-III WITH SINGLE-FUNCTION GRAPPLE

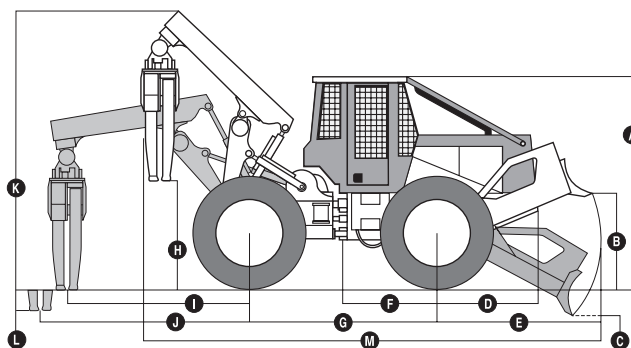

648G-III / 748G-III WITH DUAL-FUNCTION GRAPPLE

# JOHN DEERE G-III SERIES GRAPPLE SKIDDERS

## 548G-III DIMENSIONS WITH TIRES

Tire Size	23.1-26	28L-26	24.5-32	23.1-26 (narrow gauge)	28L-26 (narrow gauge)	24.5-32 (narrow gauge)
N Ground Clearance	19.6-in 498 mm	20.2-in 514 mm	23.5-in 598 mm	19.6-in 498 mm	20.2-in 514 mm	23.5-in 598 mm
O Wheel Tread	7-ft 3-in 2,21 m	7-ft 6-in 2,29 m	8-ft 2-in 2,49 m	6-ft 8.9-in 2,06 m	7-ft 2-in 2,18 m	7-ft 5-in 2,26 m
P Overall Width	9-ft 2-in 2,79 m	9-ft 10-in 3,0 m	10-ft 2.5-in 3,11 m	8-ft 8-in 2,64 m	9-ft 6-in 2,90 m	9-ft 5.5-in 2,88 m
Turning Radius Over Tires	17-ft 11-in 5,474 m	18-ft 1-in 5,512 m		17-ft 6-in 5,398 m	17-ft 6-in 5,460 m	

## 648G-III DIMENSIONS WITH TIRES

Tire Size	28L-26	24.5-32	30.5-32	28L-26 (narrow gauge)	24.5-32 (narrow gauge)
N Ground Clearance	20.2-in 514 mm	23.5-in 598 mm	24.2-in 615 mm	20.2-in 514 mm	23.5-in 598 mm
O Wheel Tread	7-ft 10.5-in 2,40 m	8-ft 2-in 2,49 m	8-ft 1-in 2,46 m	7-ft 6.5-in 2,29 m	7-ft 5-in 2,26 m
P Overall Width	10-ft 2.5-in 3,11 m	10-ft 2.5-in 3,11 m	10-ft 7.5-in 3,23 m	9-ft 10.5-in 3,01 m	9-ft 5.5-in 2,88 m
Turning Radius Over Tires	DD: 18-ft 9-in 5,7 m / TC: 19-ft 0-in 5,8 m				

## 748G-III DIMENSIONS WITH TIRES

Tire Size	24.5-32	30.5-32
N Ground Clearance	22.9-in 582 mm	23.6-in 599 mm
O Wheel Tread	8-ft 2-in 2,49 m	8-ft 1-in 2,46 m
P Overall Width	10-ft 2.5-in 3,11 m	10-ft 7.5-in 3,23 m
Turning Radius Over Tires	19-ft 10-in 6,04 m	

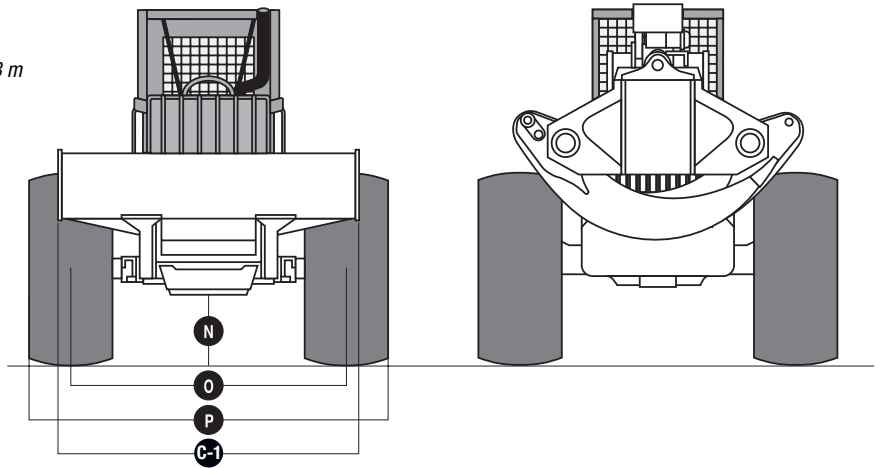

## DIMENSIONS WITH GRAPPLE

548G-III

648G-III

748G-III

### STANDARD GRAPPLE HEAD

Q Tong Opening At Tips	7-ft 1-in 2 160 mm	9-ft 7-in 2 921 mm	10-ft 5-in 3 175 mm
R Enclosure Area, Tongs Tip To Tip	8 sq-ft 0,75 m <sup>2</sup>	10.4 sq-ft 0,97 m <sup>2</sup>	12.5 sq-ft 1,16 m <sup>2</sup>
S Minimum Diameter Of Stem	5-in 24 mm	5.5-in 140 mm	5.2-in 132 mm

### HIGH-CAPACITY GRAPPLE HEAD

Q Tong Opening At Tips	10-ft 5-in 3 175 mm	10-ft 7-in 3 226 mm
R Enclosure Area, Tongs Tip To Tip	12.5 sq-ft 1,16 m <sup>2</sup>	14.9 sq-ft 1,38 m <sup>2</sup>
S Minimum Diameter Of Stem	5.2-in 132 mm	6.0-in 152 mm

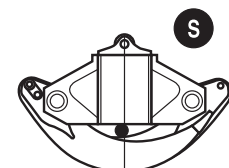
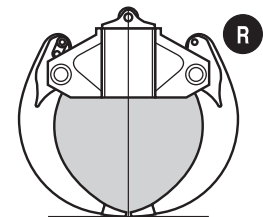
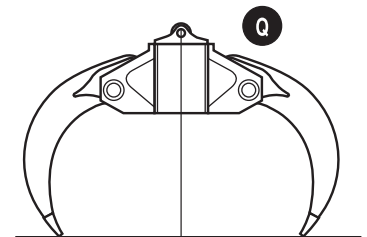

# TECHNICAL DATA 540G-III 640G-III CABLE SKIDDERS

## ENGINE

	540G-III	640G-III
Type .....	John Deere 6068T, 6 cylinder, meets EPA and CARB emission non-road regulations, with altitude compensating spark-arresting turbocharger	John Deere 6068H, 6-cylinder, meets EPA and CARB emission non-road regulations, with altitude compensating spark-arresting turbocharger
Rated Power @ 2,200 rpm .....	129 SAE gross hp <i>96 kW</i>	171 SAE gross hp <i>128 kW</i>
With Torque-Converter Option .....		185 SAE gross hp <i>138 kW</i>
Displacement .....	414 cu-in <i>6,8 L</i>	414 cu-in <i>6,8 L</i>
Maximum Gross Torque .....	32% @ 1,400 rpm / <i>407 lb-ft 552 Nm</i>	28% @ 1,400 rpm / <i>521 lb-ft 706 Nm</i>
With Torque-Converter Option .....		40% @ 1,400 rpm / <i>618 lb-ft 838 Nm</i>
Air Cleaner.....	Dual stage with safety element and dust unloader valve	Dual stage with safety element and dust unloader valve
Cooling System.....	Heavy-duty radiator with in-line core coolant recovery reservoir	Heavy-duty radiator with in-line core coolant recovery reservoir
Cooling Fan.....	Blower	Sucker
Lubrication .....	Pressure system with oil cooler.....	Pressure system with oil cooler
Oil Filter .....	Vertically mounted spin-on.....	Vertically mounted spin-on
Electrical System .....	12 volt with 90-amp alternator.....	12 volt with 90-amp alternator
Battery (two 12 volt) .....	Reserve capacity: 360 min, 1,850 CCA	Reserve capacity: 360 min, 1,850 CCA

## TRANSMISSION

Type .....	Direct-drive power shift*	Direct-drive power shift*
Oil Filtration .....	10 micron pressure side with bypass.....	10 micron pressure side with bypass

\*Power shift with torque converter optional on 640G-III only

## AXLES

Final Drives.....	Heavy-duty planetary, mounted inboard.....	Heavy-duty planetary, mounted inboard
Differentials .....	Hydraulic locking, operated on the go .....	Hydraulic locking, operated on the go
Front Axle Oscillation .....	30 degrees, stop to stop .....	30 degrees, stop to stop

## BRAKES

Service Brakes .....	Long-life, inboard-mounted wet disc oil cooled, self-adjusting and self-equalizing front and rear axles
Parking Brake .....	Automatically spring-applied, hydraulically released, sealed and lubricated, wet multi-disc, integrally mounted in transmission

## STEERING

Frame Articulation.....	90 degrees total, stop to stop.....	90 degrees total, stop to stop
Steering Wheel With Orbitrol™ Valve		

## POWER TRAIN PERFORMANCE

	540G-III with 28L-26 tires		640G-III DIRECT DRIVE with 30.5-32 tires	
No Tire Slip .....	Maximum Speed .....	Maximum Drawbar .....	Maximum Speed .....	Maximum Drawbar .....
	@ 2,200 rpm	@ peak torque	@ 2,200 rpm	@ peak torque
Forward				
Gear 1 .....	1.4 mph <i>2,3 km/hr</i> .....	31,143 lb <i>139 kN</i> .....	1.7 mph <i>2,7 km/hr</i> .....	36,139 lb <i>161 kN</i>
Gear 2 .....	1.9 mph <i>3,0 km/hr</i> .....	23,465 lb <i>104 kN</i> .....	2.2 mph <i>3,5 km/hr</i> .....	27,229 lb <i>121 kN</i>
Gear 3 .....	2.5 mph <i>4,0 km/hr</i> .....	17,628 lb <i>78 kN</i> .....	2.9 mph <i>4,7 km/hr</i> .....	20,479 lb <i>91 kN</i>
Gear 4 .....	3.3 mph <i>5,3 km/hr</i> .....	13,280 lb <i>59 kN</i> .....	3.9 mph <i>6,3 km/hr</i> .....	15,428 lb <i>69 kN</i>
Gear 5 .....	4.4 mph <i>7,1 km/hr</i> .....	9,950 lb <i>44 kN</i> .....	5.2 mph <i>8,4 km/hr</i> .....	11,559 lb <i>51 kN</i>
Gear 6 .....	5.9 mph <i>9,5 km/hr</i> .....	7,482 lb <i>33 kN</i> .....	6.9 mph <i>11,1 km/hr</i> .....	8,692 lb <i>39 kN</i>
Gear 7 .....	8.7 mph <i>14,0 km/hr</i> .....	5,053 lb <i>22 kN</i> .....	10.2 mph <i>16,4 km/hr</i> .....	5,864 lb <i>26 kN</i>
Gear 8 .....	11.6 mph <i>18,7 km/hr</i> .....	3,792 lb <i>17 kN</i> .....	13.6 mph <i>21,9 km/hr</i> .....	4,400 lb <i>19 kN</i>
Reverse				
Gear 1 .....	1.4 mph <i>2,3 km/hr</i> .....	31,143 lb <i>139 kN</i> .....	1.7 mph <i>2,7 km/hr</i> .....	36,139 lb <i>161 kN</i>
Gear 2 .....	1.9 mph <i>3,0 km/hr</i> .....	23,465 lb <i>104 kN</i> .....	2.2 mph <i>3,5 km/hr</i> .....	27,229 lb <i>121 kN</i>
Gear 3 .....	2.5 mph <i>4,0 km/hr</i> .....	17,628 lb <i>78 kN</i> .....	2.9 mph <i>4,7 km/hr</i> .....	20,479 lb <i>91 kN</i>
Gear 4 .....	3.3 mph <i>5,3 km/hr</i> .....	13,280 lb <i>59 kN</i> .....	3.9 mph <i>6,3 km/hr</i> .....	15,428 lb <i>69 kN</i>
Gear 5 .....	4.4 mph <i>7,1 km/hr</i> .....	9,950 lb <i>44 kN</i> .....	5.2 mph <i>8,4 km/hr</i> .....	11,559 lb <i>51 kN</i>
Gear 6 .....	5.9 mph <i>9,5 km/hr</i> .....	7,482 lb <i>33 kN</i> .....	6.9 mph <i>11,1 km/hr</i> .....	8,692 lb <i>39 kN</i>
Gear 7 .....	8.7 mph <i>14,0 km/hr</i> .....	5,053 lb <i>22 kN</i> .....	10.2 mph <i>16,4 km/hr</i> .....	5,864 lb <i>26 kN</i>

## HYDRAULIC SYSTEM

Pump.....	Variable-displacement axial piston .....	Variable-displacement axial piston
Maximum Rated Flow .....	27 gpm 102 L/min @ 2,200 rpm .....	27 gpm 102 L/min @ 2,200 rpm
Pressure .....	3,000 psi 20 684 kPa .....	3,000 psi 20 684 kPa
Oil Filtration .....	One 10 micron return oil with bypass .....	One 10 micron return oil with bypass

## 540G-III

## 640G-III DIRECT DRIVE

## WINCH

Type .....	Sealed, wet multi-disc clutch and brake .....		Sealed, wet multi-disc clutch and brake		
	pressurized lubrication single lever control		pressurized lubrication single lever control		
Cable Capacity	4000 (8-in drum)	4000 (10-in drum)	4000 (8-in drum)	4000 (10-in drum)	6000 (11-in drum)
0.625-in 15,8 mm cable .....	254-ft 77,4 m.....	199-ft 60,6 m.....	254-ft 77,4 m.....	199-ft 60,6 m.....	373-ft 114 m
0.75-in 19,1 mm cable .....	179-ft 54,6 m.....	141-ft 43 m.....	179-ft 54,6 m.....	141-ft 43 m.....	263-ft 80,2 m
0.875-in 22,2 mm cable .....	129-ft 39,3 m.....	101-ft 30,8 m.....	129-ft 39,3 m.....	101-ft 30,8 m.....	189-ft 58 m
1-in 25,4 mm cable .....	100-ft 30,5 m.....	78-ft 23,8 m.....	100-ft 30,5 m.....	78-ft 23,8 m.....	147-ft 45 m

### Linepull @ Peak Engine,

0.625-in 15,8 mm cable	Bare Drum	Full Drum	Bare Drum	Full Drum
4000 (8-in drum high speed) .....	30,068 lb 134 kN.....	18,150 lb 81 kN.....	37,296 lb 166 kN.....	22,377 lb 100 kN
4000 (8-in drum standard speed).....	35,029 lb 156 kN.....	21,145 lb 94 kN.....	43,449 lb 193 kN.....	26,069 lb 116 kN
4000 (10-in drum high speed) .....	28,435 lb 127 kN.....	21,145 lb 99 kN.....	35,270 lb 157 kN.....	26,069 lb 116 kN
6000 (11-in drum high speed) .....			37,839 lb 168 kN.....	23,615 lb 105 kN

### Line Speed @ 2,200 rpm,

0.625-in 15,8 mm cable	Bare Drum	Full Drum	Bare Drum	Full Drum
4000 (8-in drum high speed) .....	142 fpm .....	236 fpm .....	142 fpm .....	236 fpm
	43,2 m/min	72,0 m/min	43,2 m/min	72,0 m/min
4000 (8-in drum standard speed).....	122 fpm .....	203 fpm .....	122 fpm .....	203 fpm
	37,1 m/min	61,8 m/min	37,1 m/min	61,8 m/min
4000 (10-in drum high speed) .....	150 fpm .....	203 fpm .....	150 fpm .....	203 fpm
	45,7 m/min	61,8 m/min	45,7 m/min	61,8 m/min
6000 (11-in drum high speed) .....			128 fpm .....	205 fpm
			39,0 m/min	62,5 m/min

## GROUND PRESSURE DATA

### Tires

23.1-26 .....	8.3 psi 57,1 kPa	
28L-26 .....	6.8 psi 46,9 kPa	8.4 psi 57,9 kPa
24.5-32 .....	7.3 psi 50,3 kPa	9.0 psi 62,0 kPa
30.5-32 .....	6.1 psi 42,0 kPa	7.5 psi 51,7 kPa
67/34-25 or 26 .....	6.3 psi 43,4 kPa	7.6 psi 52,4 kPa
66/43-25 or 26 .....	5.5 psi 37,9 kPa	6.6 psi 45,5 kPa
68/50-32 .....		5.1 psi 35,1 kPa

## CAPACITIES [U.S.]

Fuel Tank.....	42.0 gal 159,0 L.....	42.0 gal 159,0 L
Cooling System.....	30 qt 24,6 L.....	36 qt 34,4 L
Engine Lubrication, Including Filter .....	20 qt 18,9 L.....	20 qt 18,9 L
Transmission .....	7.8 gal 29,3 L.....	7.8 gal 29,3 L
Differentials		
Front.....	4.5 gal 17 L.....	4.5 gal 17 L
Rear.....	4.5 gal 17 L.....	7.5 gal 28,4 L
Winch.....	9.3 gal 35,2 L.....	9.3 gal 35,2 L
Hydraulic Reservoir.....	8 gal 30,3 L.....	14.3 gal 54 L

## OPERATING WEIGHTS

Standard Equipment .....	22,780 lb 10 355 kg .....	30,025 lb 13 648 kg
	(23.1 x 26 tires)	(30.5 x 32 tires)

## JOHN DEERE G-III SERIES CABLE SKIDDERS

DIMENSIONS	540G-III	640G-III DD
Tire Size.....	28L-26.....	28L-26.....
A Overall Height*.....	9-ft 10.5-in..... 3,01 m	9-ft 11-in..... 3,03 m
B Maximum Blade Lift Above Ground.....	3-ft 11.6-in..... 1,21 m	4-ft 3.5-in..... 1,31 m
C Maximum Blade Dig Below Ground.....	11.3-in..... 288 mm	14.5-in..... 367 mm
C-1 Dozer Blade Width.....	7-ft 2-in..... 2184 mm	7-ft 2-in..... 2184 mm
Optional.....		9-ft 8-in..... 2964 mm
D Front Axle To Front Of Machine.....	4-ft 11.3-in..... 1 507 mm	5-ft 6.3-in..... 1 685 mm
E Front Axle To Blade Cutting Edge Arc.....	6-ft 11.2-in..... 2 112 mm	7-ft 6.2-in†..... 2 292 mm
F Front Axle To Articulation Joint.....	5-ft 2-in..... 1 575 mm	5-ft 8-in†..... 1 727 mm
G Wheelbase.....	9-ft 7-in..... 2 920 mm	11-ft 3-in†..... 3 430 mm
H Overall Length.....	20-ft 9.0-in..... 6 330 mm	23-ft 8.6-in†..... 7 230 mm

\*Add 6.3 in 160 mm when equipped with water tank  
 †Add 2.0 in 50,8 mm for machines equipped with a torque converter  
 ‡Add 7.2 in 182,9 mm for machines equipped with a torque converter

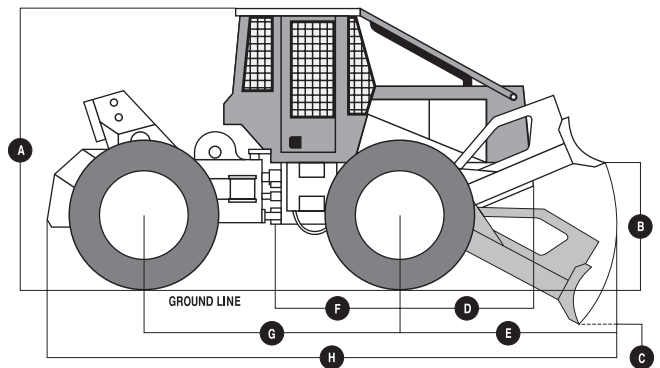
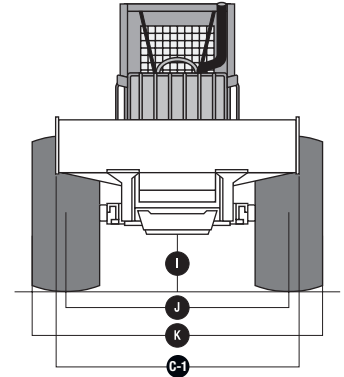

### 540G-III DIMENSIONS WITH TIRES

Tire Size	23.1-26	28L-26	24.5-32	23.1-26 (narrow gauge)	28L-26 (narrow gauge)	24.5-32 (narrow gauge)
I Ground Clearance.....	19.6-in..... 498 mm	20.2-in..... 514 mm	23.5-in..... 598 mm	19.6-in..... 498 mm	20.2-in..... 514 mm	23.5-in..... 598 mm
J Wheel Tread.....	7-ft 3-in..... 2,21 m	7-ft 6-in..... 2,29 m	7-ft 9.5-in..... 2,38 m	6-ft 9-in..... 2,06 m	7-ft 2-in..... 2,18 m	7-ft 0.5-in..... 2,15 m
K Overall Width.....	9-ft 2-in..... 2,79 m	9-ft 10-in..... 3,00 m	9-ft 10-in..... 3,00 m	8-ft 8-in..... 2,64 m	9-ft 6-in..... 2,90 m	9-ft 1-in..... 2,77 m

### 640G-III DIMENSIONS WITH TIRES

Tire Size	23.1-26	28L-26	24.5-32	30.5-32	23.1-26 (narrow gauge)	28L-26 (narrow gauge)	24.5-32 (narrow gauge)
I Ground Clearance.....	19.6-in..... 498 mm	20.2-in..... 514 mm	23.5-in..... 598 mm	24.2-in..... 615 mm	19.6-in..... 498 mm	20.2-in..... 514 mm	23.5-in..... 598 mm
J Wheel Tread.....	7-ft 3-in..... 2,21 m	7-ft 6-in..... 2,28 m	7-ft 9.5-in..... 2,38 m	7-ft 8.5-in..... 2,35 m	6-ft 9-in..... 2,06 m	7-ft 2-in..... 2,18 m	7-ft 0.5-in..... 2,15 m
K Overall Width.....	9-ft 2-in..... 2,79 m	9-ft 10-in..... 3,00 m	9-ft 10-in..... 3,00 m	10-ft 3-in..... 3,12 m	8-ft 8-in..... 2,64 m	9-ft 6-in..... 2,90 m	9-ft 1-in..... 2,77 m

## OPERATOR'S STATION

### GRAPPLE AND CABLE SKIDDERS

Accessory power ports (2),  
12-volt/15-amp fuse  
Beverage holder  
Cab hydraulic tilt for service  
Canopy with tinted polycarbonate front windows and screens on all other openings / Heater, 40,000 Btu/hr *11.8 kW*  
Cell-phone storage compartment and power port in right-hand armrest  
Deluxe interior trim package  
Dome light  
Door storage bins  
Fire extinguisher, 5 lb  
Floor mat  
Foot throttle  
Front wiper with washer  
Full Function Monitor Instrumentation:  
Illuminated Gauges: Fuel level, Engine Coolant Temperature, Transmission Oil Temperature;  
Audible Warning Alarm for: Transmission Oil Temperature High, Engine Coolant High, Engine Oil Pressure Low, Hydraulic Oil Temperature High;  
Indicator lights for: Check Service Code, Engine Air Filter Restriction, Transmission Oil Filter Restriction, Hydraulic Oil Filter Restriction, Engine Oil Pressure, Differential Lock, Engine Alternator Volts, Fasten Seat Belt/Park Brake; and Selectable digital readout for: Hourmeter, Gear Selection, Battery Voltage, Engine PRM, Hydraulic Oil Temperature, Transmission and Engine fault codes  
Full heating and ventilation ducting  
Lockable doors with start switch key  
Meets noise regulation: SAE J1166 (OSHA and BC)  
Mirror, interior rearview  
Operator manual with storage compartment  
Operator protection with integral ROPS, FOPS, and OPS structure  
Seat belt, 2-in *51 mm* retractable  
Sunscreen (front and rear)  
Sunvisor (front)  
Swivel seat with 15-, 22.5-, and 30-degree positions  
Tilt-telescopic steering wheel with spinner knob  
Vinyl cushion/mechanical suspension seat with: Fore/aft adjustment / Height, weight adjustment / Adjustable backrest angle / Armrests, two position

## GRAPPLE SKIDDER OPTIONAL FEATURES

### ENGINE

Electric ether starting aid (548 and 748 only)

### ELECTRICAL

Work lights (halogen, 2 front, 2 rear)

Work lights (halogen, 4 front, 4 rear)

### TRANSMISSION

Power shift with torque converter with six forward and three reverse speeds (648 only)

Transmission disconnect, for cold weather starting (648 and 748 only)

### OPERATOR'S STATION

Cab, fully enclosed, with polycarbonate windows on all openings with screens on the door windows only; also includes: Air conditioner, R134a refrigerant / Heater, 40,000 Btu/hr *11.8 kW* / Pressurizer

Fire extinguisher, 10 lb

Hand throttle

Rear wiper with washer

Seat belt, 3-in *76 mm*, anti-cinch retractable

Vinyl cushion/air suspension seat with:  
Fore/aft adjustment / Height, weight adjustment / Adjustable backrest angle / Armrests, two position

Fabric cushion/air suspension seat with:  
Fore/aft adjustment / Height, weight adjustment / Adjustable backrest angle / Armrests, two position

Fabric cushion/mechanical suspension seat with:  
Fore/aft adjustment / Height, weight adjustment / Adjustable backrest angle / Armrests, two position

AM/FM stereo sound system

AM/FM cassette stereo sound system

Cab fresh-air precleaner

Window glazing kit (canopy to cab field conversion)\*

### AXLES

1400 HD SWEDA (648 and 748 only)

### TIRES

23.1-26, 14 ply rating, narrow gauge (548 only)

28L-26, 14 ply rating (548 and 648 only)

24.5-32, 12 ply rating, narrow gauge (548 and 648 only)

24.5-32, 16 ply rating (548 and 648 only)

30.5-32, 16 ply rating

30.5-32 and 24.5-32, 16 ply rating -  
Duals (648 and 748 only)

### HYDRAULIC SYSTEM

Single-lever "pilot" grapple control  
(optional on single- and dual-function grapples)

### GRAPPLE

Dual function with 115-in tong opening (648 only)

Dual function with 125-in tong opening (648 and 748 only)

Dual function with 127-in tong opening (748 only)

### WINCH

Model 4000 (8-in drum high speed) (548 and 648 only)

Model 4000 (8-in drum standard speed) (548 and 648 only)

Model 4000 (10-in drum high speed) (548 and 648 only)

## CABLE SKIDDER OPTIONAL FEATURES

### ENGINE

Electric ether starting aid (540 only)

### ELECTRICAL

Alternator, 120 amp

Work lights (halogen, 2 front, 2 rear)

Work lights (halogen, 4 front, 4 rear)

### TRANSMISSION

Power shift with torque converter with six forward and three reverse speeds (640 only)

Transmission disconnect,  
for cold weather starting (640 DD only)

### OPERATOR'S STATION

Cab, fully enclosed, with polycarbonate windows on all openings with screens on the door windows only; also includes: Air conditioner, R134a refrigerant / Heater, 40,000 Btu/hr *11.8 kW* / Pressurizer

Fire extinguisher, 10 lb

Hand throttle

Rear wiper with washer

Seat belt, 3-in *76 mm*, anti-cinch retractable

Vinyl cushion/air suspension seat with:  
Fore/aft adjustment / Height, weight adjustment / Adjustable backrest angle / Armrests, two position

Fabric cushion/air suspension seat with:  
Fore/aft adjustment / Height, weight adjustment / Adjustable backrest angle / Armrests, two position

Fabric cushion/mechanical suspension seat with:  
Fore/aft adjustment / Height, weight adjustment / Adjustable backrest angle / Armrests, two position

AM/FM stereo sound system

AM/FM cassette stereo sound system

Premium AM/FM/CD stereo sound system (field installed)\*

Cab fresh-air precleaner

Window glazing kit (canopy to cab field conversion)\*

### TIRES

23.1-26, 14 ply rating, narrow gauge

28L-26, 12 ply rating

28L-26, 12 ply rating, narrow gauge

28L-26, 14 ply rating

24.5-32, 16 ply rating

30.5-32, 16 ply rating (640 only)

### WINCH

Model 4000 (8-in drum high speed)

Model 4000 (10-in drum high speed)

Model 6000 (11-in drum) (640 only)

Engine power is with standard equipment including air cleaner, exhaust system, alternator, and cooling fan, at standard conditions per SAE J1349 and DIN 70 020, using No. 2-D fuel at 35 API gravity. No derating is required up to 10,000 ft. (3050 m) altitude. Gross power is without cooling fan.

Specifications and design subject to change without notice. Wherever applicable, specifications are in accordance with SAE standards. Except where otherwise noted, these specifications are based on units with full fuel tanks, 175-lb. (79 kg) operators, and standard equipment: 548-III and 648-III units with 28L-26, 14 PR LS2 tires; and 748G-III unit with 30.5-32, 16 PR LS2 tires.

Photos may show features or options not available in all markets.

# SKIDDERS

GRAPPLE 548G-III 648G-III 748G-III CABLE 540G-III 640G-III



## NOTHING RUNS LIKE A DEERE.

Maybe those words are the reason why almost every other professional logger is a John Deere customer.

They're just five simple words. Yet they have profound impact on your company. Because at their heart they mean equipment that is built forest tough, with greater productivity, more uptime, and lower daily operating costs. They mean a dealer network over 380 locations strong, with immediate access to parts and experts that understand your industry. They mean a dedicated lender

in John Deere Credit, committed to helping loggers succeed with competitive financing to enhance cash flow. And they mean a global forestry equipment leader that invests more in research and development than any other manufacturer.

But most of all, these words represent the confidence that comes with over 168 years of experience.

**Your world is logging. So is ours. John Deere Forestry. Leading the way, worldwide.**

FULL TREE SYSTEM

ADVANCED HARVESTING SYSTEM



PRODUCTIVITY | UPTIME | LOW DAILY OPERATING COSTS

[www.JohnDeere.com](http://www.JohnDeere.com)



**JOHN DEERE**  
Nothing Runs Like A Deere



## Free Manuals Download Website

<http://myh66.com>

<http://usermanuals.us>

<http://www.somanuals.com>

<http://www.4manuals.cc>

<http://www.manual-lib.com>

<http://www.404manual.com>

<http://www.luxmanual.com>

<http://aubethermostatmanual.com>

Golf course search by state

<http://golfingnear.com>

Email search by domain

<http://emailbydomain.com>

Auto manuals search

<http://auto.somanuals.com>

TV manuals search

<http://tv.somanuals.com>