

**O P E R A T O R ' S M A N U A L**

# **GROOMING MOWERS**

**GM1048E**

**GM1060E**

**GM1072E**

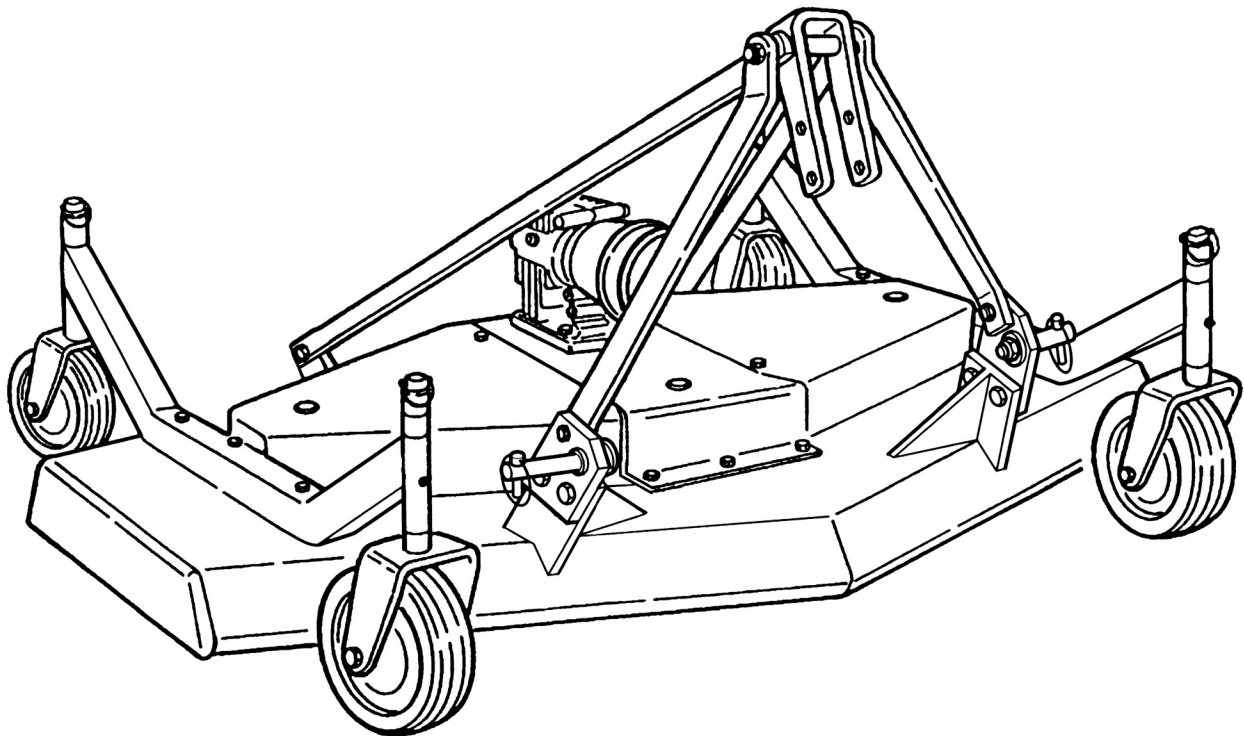

**FRONTIER**  
EQUIPMENT

Manual 5BP960379B  
Date 11/11/2010

# SAFETY

Take note! This safety alert symbol found throughout this manual is used to call your attention to instructions involving your personal safety and the safety of others. Failure to follow these instructions can result in injury or death.



*This symbol means:  
ATTENTION!  
BECOME ALERT!  
YOUR SAFETY IS INVOLVED!*

## Signal Words

Note the use of the signal words DANGER, WARNING and CAUTION with the safety messages. The appropriate signal words for each have been selected using the following guidelines:



**DANGER:** Indicates an imminently hazardous situation that, if not avoided, will result in death or serious injury.



**WARNING:** Indicates a potentially hazardous situation that, if not avoided, could result in death or serious injury, and includes hazards that are exposed when guards are removed. It may also be used to alert against unsafe practices.



**CAUTION:** Indicates a potentially hazardous situation that, if not avoided, may result in minor or moderate injury.

# INDEX

<b>1 - GENERAL INFORMATION</b>	4
1.01 - General	4
1.02 - Warranty Information	4
1.03 - Model and Serial Number ID	5
1.04 - Assembly Instructions	5
1.05 - Quick Hitch Adapter Assembly and Operation	7
<b>2 - SAFETY PRECAUTIONS</b>	10
2.01 - Preparation	10
2.02 - Starting and Stopping	11
2.03 - Messages and Signs	11
<b>3 - OPERATION</b>	14
3.01 - Operational Safety	14
3.02 - Set Up	16
3.03 - Cutting Height Adjustment	17
3.04 - Pre-Operational Check	18
3.05 - Attaching to the Tractor	18
3.06 - Start Up	19
3.07 - Working Speed	20
3.08 - Operating Techniques	21
3.09 - Uneven Terrain	22
3.10 - Removing Mower from the Tractor	23
3.11 - Transport	23
<b>4 - MAINTENANCE</b>	24
4.01 - Maintenance Safety	24
4.02 - Service	25
4.03 - Blade Maintenance	26
4.04 - Belt Tension	28
4.05 - Belt Replacement	29
4.06 - Driveline	30
<b>5 - REPAIR PROCEDURES</b>	33
5.01 - Gearbox	33
5.02 - Blade Spindle	33
5.03 - Suggested Spare Parts	33
5.04 - Storage	34
<b>6 - TROUBLESHOOTING</b>	35
<b>7 - PRE-DELIVERY CHECKLIST</b>	36
<b>PARTS MANUAL</b>	37

# 1 - GENERAL INFORMATION

Thank you and congratulations for having chosen our implement. Your new grooming mower is a technologically advanced machine constructed of high quality, sturdy components that will fulfill your working expectations. Read this manual carefully. It will instruct you on how to operate and service your mower safely and correctly. Failure to do so could result in personal injury and/or in equipment damage.

## 1.01 - General

The implement described in this manual is to be used with tractors with PTO at 540 rpm and clockwise rotation.



**CAUTION:** Always ensure that the coupling of the implement with the tractor is done at the same PTO speed and direction of rotation. Do not operate this implement at a PTO speed or direction of rotation other than that shown on the implement. Serious damage can occur to the machine and/or the operator.



**CAUTION:** Unless otherwise specified, all hardware is metric. Use only metric tools on metric hardware. Other tools that do not fit properly can slip and cause injury.



**CAUTION:** Right hand and left hand sides of the implement are determined by facing in the direction the implement will travel when going forward (see fig. 5).

## 1.02 - Warranty Information

Warranty coverage is provided by John Deere according to the terms of the Agricultural/Commercial & Consumer Equipment Warranty Statement. Carefully read the warranty statement on the back of your original purchase order for details on coverage and limitations of this warranty.

Your Authorized Company Dealer has genuine parts in stock. Only these approved replacement parts should be used.

### 1.03 - Model and Serial Number ID

Attached to the frame is an ID plate showing the model and the serial number. Record your implement model and serial number in the space provided below. Your dealer needs this information to give you prompt, efficient service when you order parts.



### 1.04 - Assembly Instructions



**CAUTION:** Stand clear of bands when cutting as they could be under sufficient tension to cause them to fly loose. Take care in removing bands and wire. They often have extremely sharp edges and cut very easily.

Note: All hardware needed for assembly will be found in the hardware bag or on the machine. Assembly will be easier if all parts are loosely assembled before tightening the hardware.

Each unit is shipped in a crate as a kit that consists of the following:	
Description	Q.ty
Main frame assembly	1
Top hitch arms	2
Wheel arms w/yokes	2
Wheels	4
Driveline	1
<b>Hardware bag contains the following:</b>	
Parts used to assemble wheels:	
Bolt HH M14-2.00x140 C8.8 Z P (#5BP0006615)	4
Nut PT M14-2.00 C6 Z TK (#5BP0030358)	4
Wheel spacer (#5BP0008528)	4
Parts used to assemble wheel arm:	
Bolt HH M10-1.50x90 C8.8 Z P (#5BP0026185)	6
Washer flat Ø11 W (#5BP0051776)	6
Washer flat Ø10 W (#5BP0002034)	6
Washer lock Ø10 Z (#5BP0001280)	6
Nut HH M10-1.50 C6 TK Z (#5BP0001279)	6

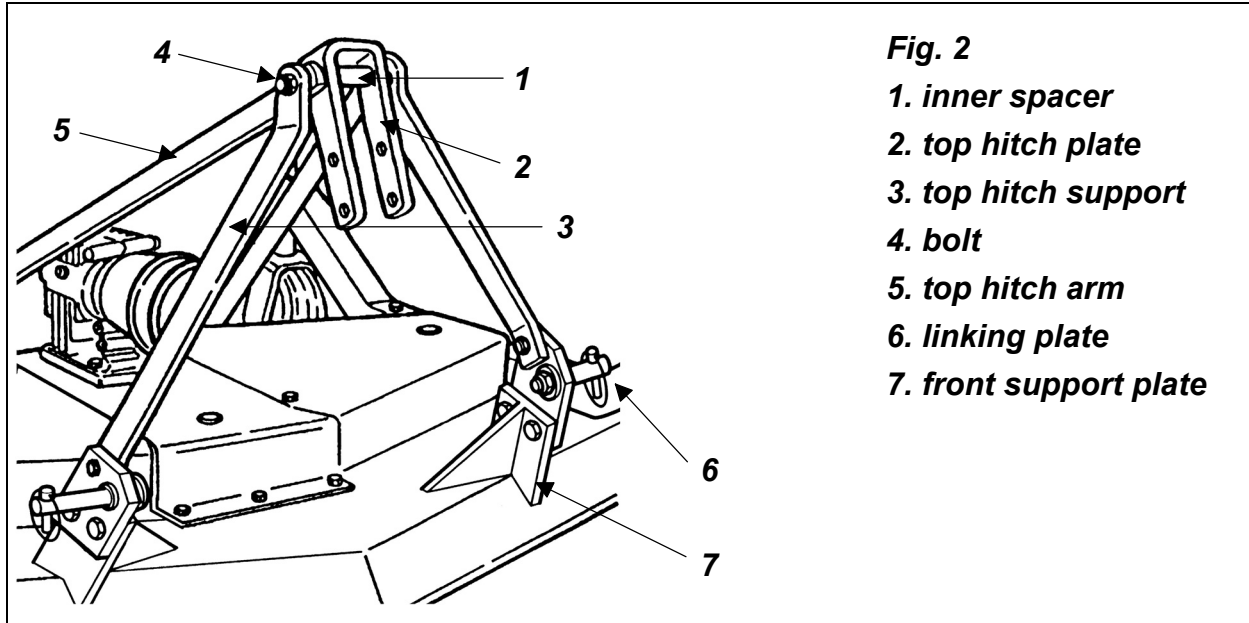
**Fig. 2**

- 1. inner spacer**
- 2. top hitch plate**
- 3. top hitch support**
- 4. bolt**
- 5. top hitch arm**
- 6. linking plate**
- 7. front support plate**

To assemble the mower proceed as follows:

1. Unbolt the wheel arms and discard the mounting bracket.
2. Separate the wheel arms and remove the hardware bag secured between them.
3. **IMPORTANT: Remove the belt shields to inspect around the belt area and under the gearbox central plate to be sure the area is clear of packing material such as blocks of wood, paper, etc.**
4. Bolt the wheel arm assemblies to the mower deck with the flat washer and locknuts. There is no difference between left/right or front/rear. Be sure both assemblies are securely mounted.
5. Assemble each wheel to the yokes with one M14x140 bolt and one inner bushing. Tighten down snugly. The wheel should turn freely but have no side to side movement.
6. Replace the belt shields.
7. Bolt up the top hitch arms (see #5, fig. 2 & 3) to the **outside** of the rear support plates on the rear of the mower (see #8, fig. 3).
8. Bolt up the top hitch supports (see #3, fig. 2 & 3) to the **inside** of the linking plates (see #6, fig. 2) that are already bolted to the **outside** of the front support plates (see #7, fig. 2).
9. Bolt up the top hitch plate (see #2, fig. 2 & 3) with the M16x140 bolt. It should be bolted as follows: bolt, top hitch support, top hitch arm, top hitch plate, spacer, top hitch plate, top hitch arm, top hitch support, locknut. **Tighten the locknut down securely, the top hitch plate should be able to swivel 360°.**
10. Grease, wheel arms, and spindles. Check the gearbox for oil. It should be approximately  $\frac{1}{2}$  filled.
11. Install driveline and ensure it has at least 2" from bottoming out in its shortest working position and has the minimum 6" overlap in its longest working position. Refer to **Section 4.06<sup>1</sup>** of this manual, if it is determined that the driveline is too long

<sup>1</sup> See Section 4.06 - Driveline, for instructions on how to determine correct driveline length and

and needs to be shortened. Contact your local dealer if it is determined that the driveline is too short for your tractor.

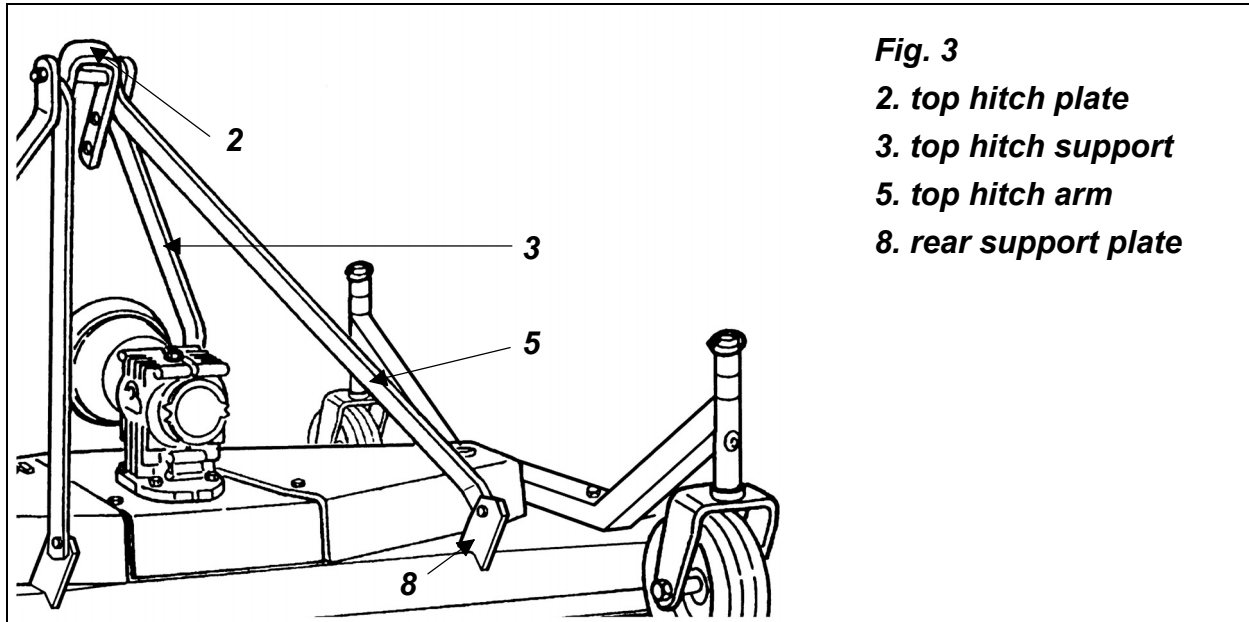

**Fig. 3**

- 2. top hitch plate**
- 3. top hitch support**
- 5. top hitch arm**
- 8. rear support plate**

## 1.05 - Quick Hitch Adapter Assembly and Operation

### Using an iMatch/Quick Hitch system:

The GM1 series mowers can be used with an iMatch/Quick Hitch system, allowing for quick and easy hookup, by installing an optional adapter. This optional adapter has floating yokes that will allow the mower to follow the contour of the ground.



**WARNING:** When using an iMatch/Quick Hitch on a PTO driven implement always ensure there is the proper driveline overlap prior to use. If there is not the minimum 6" overlap do not use and contact your nearest dealer to purchase a longer driveline.

### iMatch/Quick Hitch Adapter assembly (see fig. 4):

1. Remove hitch pins from grooming mower's linking plates.
2. Remove M16x140 bolt on top of the three point hitch of the grooming mower.
3. Remove M20x45 bolts that hold the top hitch supports to the linking plates of the mower.
4. Attach the floating yokes of quick hitch adapter assembly to the linking plates of the mower. Note: Two ½" long bushings for the floating yokes are provided in the hardware bag of the quick hitch adapter kit. Ensure these spacers are installed onto the M16x60 bolt.

procedures for shortening the driveline.

5. Attach the floating top link to the top hitch arms using the M16x90 bolt and stover nut.
6. Attach the A-frame support to the floating top link using the M16x110 bolt with stover nut.
7. Install the M20x110 bolt with the 1-1/8" spacer into the A-frame support.
8. Insert the M20x140 bolt into the floating yokes. The order should be as follows: bolt, first half of floating yoke, 1-3/8" bushing, A-frame support, M20 jam nut, second half of floating yoke, M20 stover nut. The two M20 jam nuts need to be jammed against each side of the linking plates of the grooming mower. This will allow some motion in the bushing.
9. Loosen the M16x40 bolts that secure the top hitch arms to the rear support plates of the mower. Only loosen slightly. The arms must be able to move slightly up and down.
10. Tighten all hardware, ensuring all bolts and nuts have enough play to allow quick hitch adapter to move up and down.

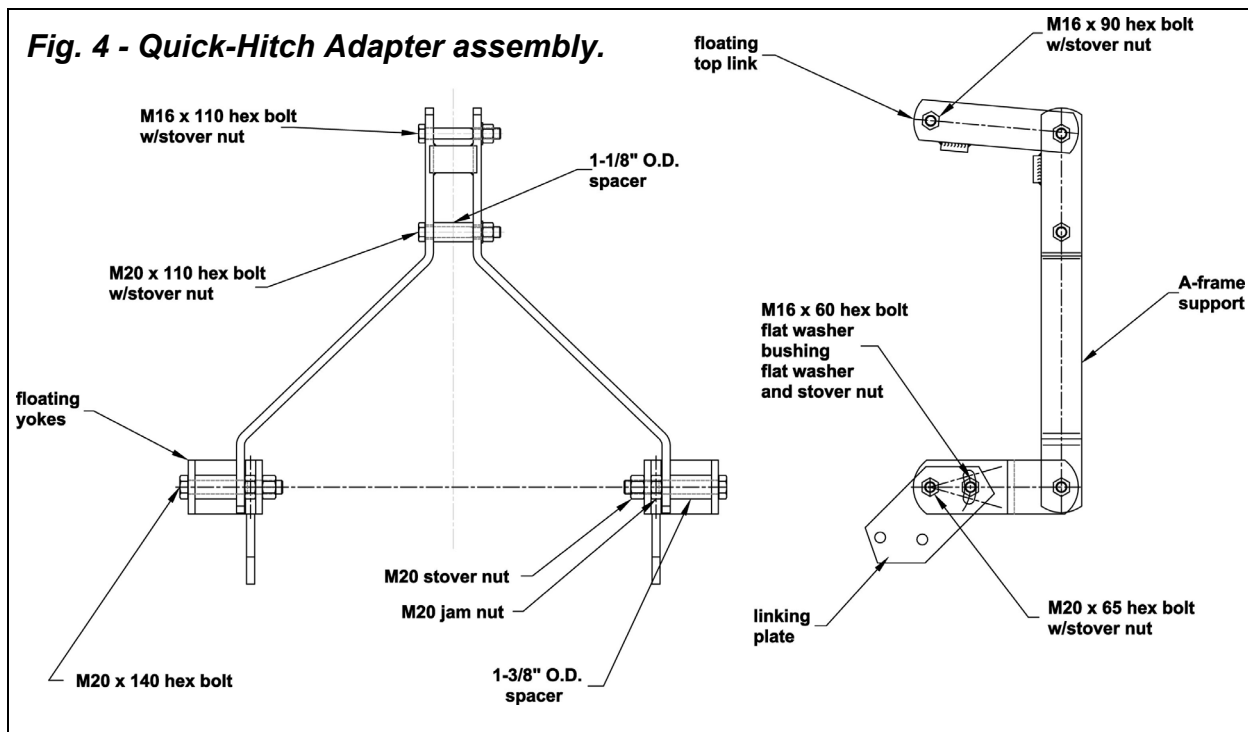

#### iMatch/Quick Hitch adapter operation:

After completing assembly of the adapter, the tractor lift arms should be raised and locked in a position so the floating yokes are horizontal. Ensure that the M16x60 bolt is approximately in the center of the slot on the floating yoke. Positioning the bolt in this location allows the mower to have maximum float both up and down.





**CAUTION:** Improper setup of the quick hitch adapter can result in equipment damage. A replacement driveline must generally be installed to prevent injury or equipment damage when using the quick hitch adapter.



**CAUTION:** If the three point hitch of the tractor is set in the lowest position, the driveline may bottom out against the quick hitch resulting in a bent driveline. If the mower is lifted after the driveline has been bent, it may also damage the gearbox, mounting plates and other hardware.

## 2 - SAFETY PRECAUTIONS

Safety is the primary concern in the design and manufacture of our products. Unfortunately our efforts to provide safe equipment can be wiped out by a single careless act of an operator.

In addition to the design and configuration of equipment, hazard control and accident prevention are dependent upon the awareness, concern, prudence and proper training of personnel involved in the operation, transport, maintenance and storage of equipment. It is the operator's responsibility to read and understand all safety and operating instructions in the manual and to follow these.

Allow only properly trained personnel to operate the mower. Working with unfamiliar equipment can lead to careless injuries. Read this manual, and the manual for your tractor, before assembly or operation, to acquaint yourself with the machines. It is the mower owner's responsibility, if this machine is used by any person other than yourself, is loaned or rented, to make certain that the operator, prior to operating, reads and understands the operator's manuals and is instructed in safe and proper use.

### 2.01 - Preparation



1. Before operating equipment read and understand the operator's manual and the safety signs (**see fig. 5**).
2. Thoroughly inspect the implement before initial operation to assure that all packaging materials, i.e. wires, bands, and tape have been removed.
3. Personal protection equipment including hard hat, safety glasses, safety shoes, and gloves are recommended during assembly, installation, operation, adjustment, maintaining and/or repairing the implement.
4. Operate the mower only with a tractor equipped with an approved Roll-Over-Protective-System (ROPS). Always wear your seat belt. Serious injury or even death could result from falling off the tractor.
5. Clear area to be cut of stones, branches or other debris that might be thrown, causing injury or damage.
6. Operate only in daylight or good artificial light.
7. Ensure mower is properly mounted, adjusted and in good operating condition.
8. Ensure that all safety shielding and safety signs are properly installed and in good condition.

## 2.02 - Starting and Stopping



1. Be sure that no one is near the machine prior to engaging or while the machine is working.
2. Be sure the tractor is in "Neutral" before starting engine.
3. Mower operating power is supplied from tractor PTO. Refer to your tractor manual for PTO engagement and disengagement instructions. Always operate PTO at 540 rpm. Know how to stop the tractor and mower quickly in case of an emergency.
4. When engaging PTO, the engine rpm should always be low. Once engaged and ready to start cutting, raise PTO speed to 540 rpm and maintain throughout cutting operation.
5. Check the tractor master shield over the PTO stub shaft. Make sure it is in good condition and fastened securely to the tractor. Purchase a new shield if old shield is damaged or missing.
6. After striking an obstacle, disengage the PTO, shut the tractor down and thoroughly inspect for damage before restarting.
7. Never engage the PTO until the mower is in the down position and resting on the ground. Never raise the mower until all blades have come to a complete stop.
8. To park the vehicle safely, stop vehicle on a level surface (not on a slope), disengage PTO, engage the parking brake, stop the engine, remove the key, and wait for engine and all moving parts to stop before leaving the operator's seat.
9. Stay clear of rotating drivelines. Entanglement in rotating driveline can cause serious injury or death. Wear close fitting clothing. Stop the engine and be sure PTO driveline is stopped before getting near it.

## 2.03 - Messages and Signs



1. Read and adhere to all safety and operating decals on this machine (**see fig. 5**).
2. Before dismounting tractor: Allow moving parts to stop, stop engine, set brake and remove the key of unattended equipment.
3. Keep away from rotating blades and driveline.
4. Keep guards and shields in place and in good condition.
5. Do not mow with bystanders in area.
6. Allow no riders on tractor or mower.
7. Allow moving parts to stop before repair.
8. Securely support mower before working underneath.

Additional warning and operating decals are available at no extra charge. Please specify model and serial number when ordering.

Fig. 5 - Safety decals - implement; replace immediately if damaged.

**CAUTION**

**To avoid serious injury:**

- Read Operator's Manual before operating, servicing or repairing equipment. Follow all safety rules and instructions. (Manuals are available from your selling dealer).
- Know location and function of controls.
- Keep all shields in place and in good condition.
- Stay clear of power driven parts.
- Never allow riders.
- Never allow children or untrained persons to operate equipment.
- Keep bystanders at a safe distance away from mower during operation.
- Before moving, clear area of objects that may be thrown by blades.
- Use extra caution on uneven terrain. Decrease speed when turning.
- Tractor must be equipped with a Roll-Over-Protection-System (ROPS) and seatbelt.
- Keep foldable ROPS systems in the "locked up" position at all times.
- Keep seatbelt securely fastened.

**Before dismounting or servicing**

- Shut off engine and remove key.
- Lock parking brake.
- Wait for all movement to stop
- Lower or block up mower.

950-111B

**WARNING**

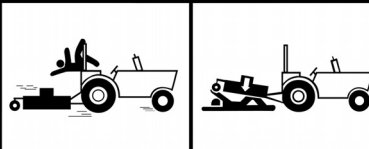

**Falling off can result in being run over.**

- Tractor must be equipped with ROPS (or ROPS CAB) and seat belt. Keep foldable ROPS system in "locked up" position at all times.
- Buckle up! Keep seat belt securely fastened.
- Allow no riders.

**Raised equipment can drop and crush.**

- Before working underneath, follow all instructions and safety rules in operator's manual and securely block all corners of equipment with jack stands.
- Securely blocking prevents equipment dropping from hydraulic leakdown, hydraulic system failures or mechanical component failures.

**Falling off or failing to block securely can result in serious injury or death.**

950-406B

**WARNING**



**Crushing and Pinching Hazard**

- Be extremely careful handling various parts of the hitching mechanism. They are heavy and hands, fingers, feet, and other body parts could be crushed or pinched between tractor and implement.
- Operate tractor controls from tractor seat only.
- Do not stand between tractor and implement when tractor is in gear.
- Make sure parking brake is engaged before going between tractor and implement.
- Stand clear of machine while in operation or when it is being raised or lowered.

**Failure to follow these instructions could result in serious injury or death.**

950-407B

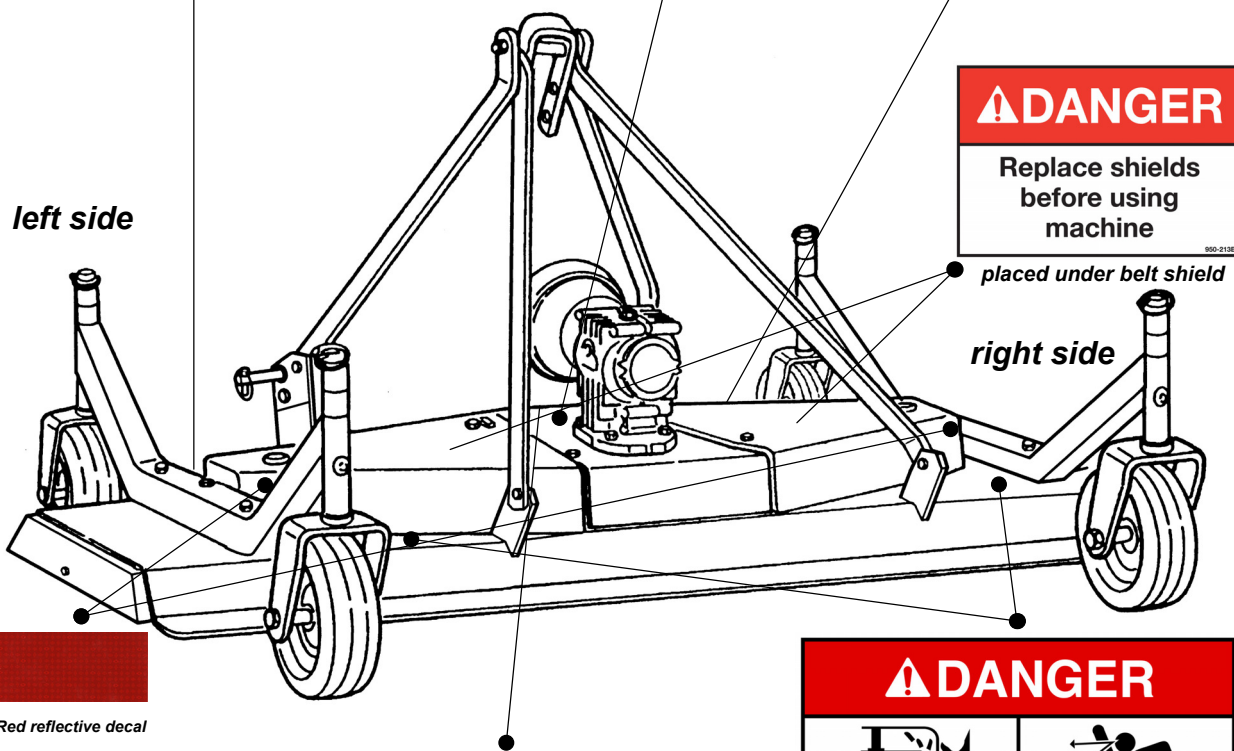

Red reflective decal

**DANGER**



**Avoid injury from PTO**

- Entanglement can cause serious injury or death.
- Keep driveline shields in place & in good condition.
- Keep hands, feet and clothing away.
- Operate only with 540 RPM.

950-109B

**DANGER**



**Rotating blades and thrown objects**

- Do not put hands or feet under or into mower when engine is running.
- Before mowing, clear area of objects that may be thrown by blades.
- Do not operate in vicinity of other persons.
- Keep guards in place and in good condition.

**Blade contact or thrown objects can cause serious injury or death.**

950-818B

**Safety decals - driveline; replace immediately if damaged.**

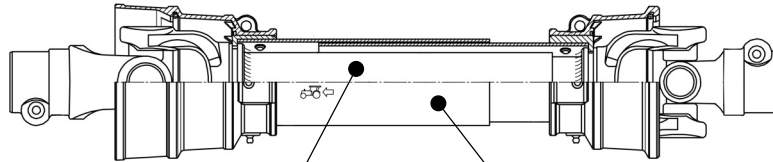

*placed on outer tube*



*placed on outer shield*

## 3 - OPERATION

You have purchased a three spindle mower designed especially for the mowing of grassy areas where a highly professional cut is required without wasting time.

This mower is perfect for the maintenance of parks, private lawns, industrial parks, airports, hospital grounds, schools, highways, golf courses, sport complexes, etc. The GM1 series, for tractors up to 30 HP, come in working widths of 4', 5' and 6' respectively. The mower can be either tractor front or rear mounted. On your mower, the tractor PTO transmits its power through a driveline to a speed multiplier gearbox. A pulley is attached to the pinion gear shaft of the gearbox which, via high resistance belts, transmits power to pulleys coupled to the three individual spindle shafts. Blades are secured to these shafts which turn at a high blade tip speed to cut the grass.

Our grooming mowers comes equipped with 4 swivel wheels. Aside from regulating the cutting height, the wheels are set in such a way as to allow the mower to follow the contour of the terrain and give a precise level cut even in undulating conditions.

### 3.01 - Operational Safety



**CAUTION:** Our mowers are designed considering safety as the most important aspect and are the safest available in today's market. Unfortunately, human carelessness can override the safety features built into our machines. Injury prevention and work safety, aside from the features on our mowers, are very much due to the responsible use of the equipment. It must always be operated prudently following with great care, the safety instructions laid out in this manual.



1. The use of this equipment is subject to certain hazards which cannot be prevented by mechanical means or product design. All operators of this equipment must read and understand this entire manual, paying particular attention to safety and operating instructions, prior to using.
2. Do not operate the tractor and mower when you are tired, sick or when using medication.
3. Keep all helpers and bystanders at least several feet from a rotary mower. Only properly trained people should operate this machine.
4. The majority of accidents involve entanglements on the driveline, injury of bystanders by objects thrown by the rotating blades, and operators being knocked off the tractor by low hanging limbs and then being run over by the mower. Accidents are most likely to occur with machines that are loaned or rented to someone who has not read the operator's manual and is not familiar with a rotary mower.

5. Always stop the tractor, set brake, shut off the tractor engine, remove the ignition key, lower implement to the ground and allow mower blades to come to a complete stop before dismounting tractor. Never leave equipment unattended with the tractor running.
6. Never place hands or feet under mower with tractor engine running or before you are sure all motion has stopped. Stay clear of all moving parts.
7. Do not allow riders on the mower or tractor at any time. There is no safe place for riders.
8. Do not operate unless all personnel, livestock and pets are several feet away to prevent injury by thrown objects.
9. Before backing up, disengage the mower and look behind carefully.
10. Install and secure all guards and shields before starting or operating.
11. Keep hands, feet, hair and clothing away from moving parts.
12. This rotary mower is designed for use only on tractors with 540 rpm power take off.
13. Never operate tractor and mower under trees with low hanging limbs. Operators can be knocked off the tractor and then run over by the rotating blades.
14. The rotating parts of this machine have been designed and tested for rugged use. However, they could fail upon impact with heavy, solid objects such as steel guard rails and concrete abutments. Such impact could cause the broken objects to be thrown outward at very high velocities. To reduce the possibility of property damage, serious injury, or even death, never allow the cutting blades to contact such obstacles.
15. Frequently check mower blades. They should be sharp, free of nicks and cracks and securely fastened.
16. Stop mower immediately upon striking an obstruction. Turn engine off, remove key, inspect and repair any damage before resuming operation.
17. Stay alert for holes, rocks and roots in the terrain and other hidden hazards. Keep away from drop-offs.
18. Use extreme care and maintain minimum ground speed when transporting on hillside, over rough ground and when operating close to ditches or fences. Be careful when turning sharp corners.
19. Reduce speed on slopes and sharp turns to minimize tipping or loss of control. Be careful when changing directions on slopes. Do not start or stop suddenly on slopes. Avoid operation on steep slopes.
20. When using a unit, a minimum 20% of tractor and equipment weight must be on tractor front wheels. Without this weight, tractor could tip over, causing personal injury or death. The weight may be attained with a front end loader, front wheel weights, ballast in tires or front tractor weights. When attaining a minimum 20% of tractor and equipment weight on the front wheels, you must not exceed the ROPS weight certification. Weigh the tractor and equipment. Do not guess or estimate!
21. Inspect the entire machine periodically<sup>2</sup>. Look for loose fasteners, worn or broken parts, and leaky or loose fittings.
22. Use only the driveline supplied with the mower. Do not use it if it is missing any shield or safety protection.

---

<sup>2</sup> See Chapter 4 - Maintenance.

23. Pass diagonally through sharp dips and avoid sharp drops to prevent "hanging up" tractor and mower.
24. Avoid sudden starts and stops while traveling up or downhill.
25. Always cut down slopes; never across the face. Avoid operation on steep slopes. Slow down on sharp turns and slopes to prevent tipping and/or loss of control.

### 3.02 - Set Up

**Notice to dealer:** Pre-delivery setup and service including lubrication is the responsibility of the authorized dealer. It is up to him to assure that the machine is in perfect condition and ready to be used. It is his responsibility to ensure that the customer is aware of all safety aspects and operational procedures for the mower. He must also fill out the Pre-Delivery Checklist<sup>3</sup> prior to delivering the mower.

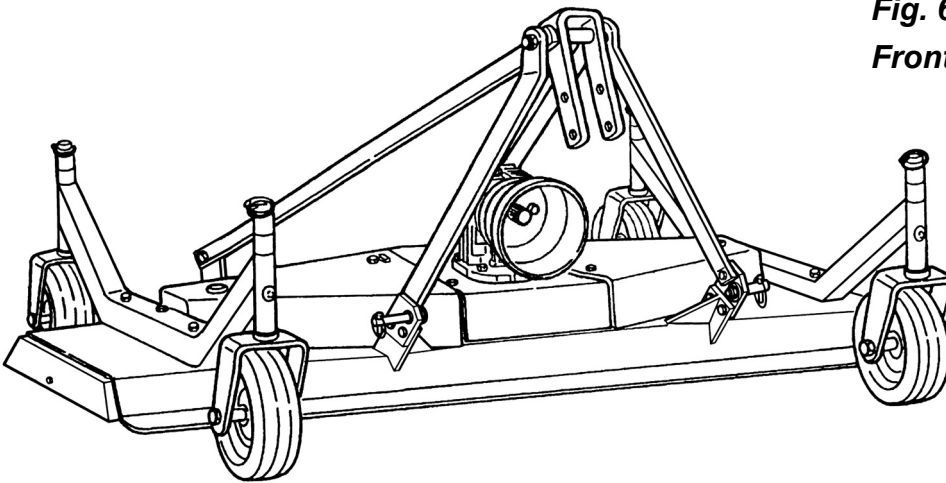

**Fig. 6**  
**Front mount mower.**

**Fig. 7**  
**Rear mount mower.**

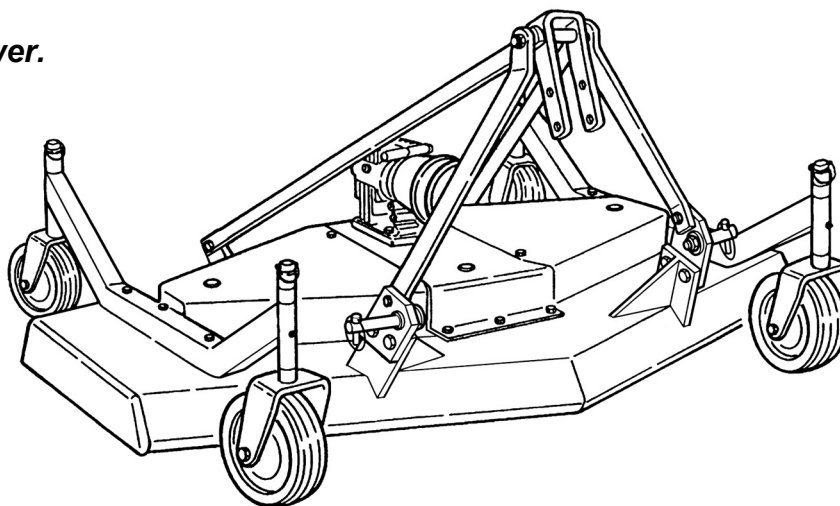

<sup>3</sup> See Chapter 7 - Pre-Delivery Checklist.



As mentioned above, all our grooming mowers may be either tractor front or rear mounted. Changing our mowers from front mount to rear, or vice versa, can be easily done at our authorized dealerships. This is accomplished by simply turning the three point hitch and the gearbox 180 degrees (see fig. 6 & 7).

### 3.03 - Cutting Height Adjustment



**WARNING:** Keep hands and feet away from moving blades.

Be sure tractor engine is off, parking brake is locked, and key is removed before making any adjustments.

Never rely on the tractor lift system. Install blocks or stands under the mower deck to prevent it from falling.

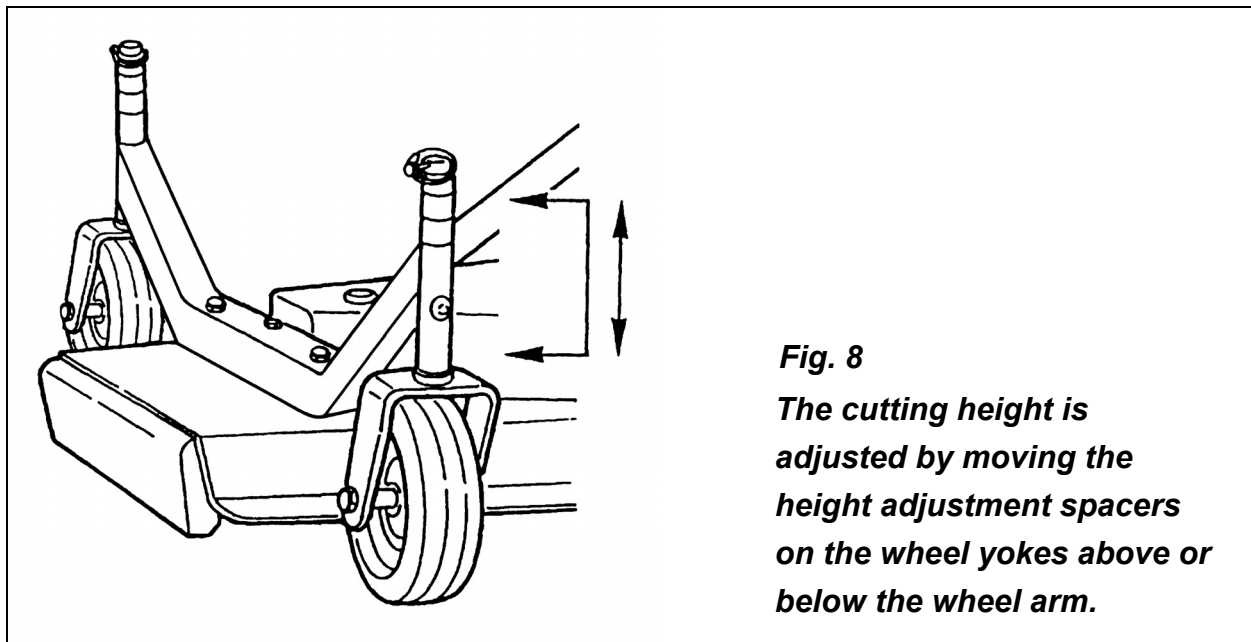

**Fig. 8**

*The cutting height is adjusted by moving the height adjustment spacers on the wheel yokes above or below the wheel arm.*

The cutting height is the distance from the blades to the ground. The cutting height is adjusted by **moving the spacers on the wheel yokes**. Placing spacers between the wheel arm and the wheel yoke raises the cutting height by the size of the spacer. Removing the spacers, lowers it by the same height (see fig. 8).

Be sure all wheel arms are adjusted equally. This is the only way to ensure a completely uniform cut.

**IMPORTANT:** Very low cutting heights should be avoided. Damaging shock loads occur when the blades strike the ground repeatedly. This can cause damage to the mower.

Cutting lower than 2" under most circumstances should be avoided.

**The cutting height is adjustable from 1" to 4".**

A front anti-scalp roller is also available upon request. This accessory is particularly helpful when cutting over uneven terrain.

### 3.04 - Pre-Operational Check

**IMPORTANT:** Check each of the following, carefully, prior to engaging the equipment:

1. The spindle bearings have been greased.
2. The belts for proper tension.
3. The oil in the gearbox.
4. The driveline cross and bearings have been greased.
5. No wrappings or foreign objects are around the blades, belts or driveline.
6. The blades are properly installed and the blade bolts properly torqued<sup>4</sup>.
7. All hardware is tight.
8. The tractor, to ensure correct direction of PTO and rpm speed.
9. All safety shields and guards are in place and tightly attached.
10. No people or animals are in the work area.
11. When working, make sure the tractor hitch is in the "float" position, in order to allow the mower to follow the contour of the ground.



**DANGER:** Stay clear of rotating driveline. Entanglement in rotating driveline can cause serious injury. Disengage PTO, engage parking brake or place transmission in "Park", shut off the tractor and remove the key before working around hitch, attaching or detaching driveline, making adjustments, servicing or cleaning the machine.

### 3.05 - Attaching to the Tractor

Unit may be used on tractors ranging from 18 to 30 HP equipped with a standard PTO and category 1 three point hitch<sup>5</sup>. **Never use this mower with tractors over 30 HP.**



**CAUTION:** Check the tractor PTO rpm to ensure it is set at 540 and turns clockwise.

---

<sup>4</sup> See Table 1, page 32.

<sup>5</sup> See Table 2, page 32.



**CAUTION:** Always ensure that the tractor tire pressure is correct according to the tractor operator's manual.



**DANGER:** Failure to ensure a secure coupling of the implement to the tractor can cause injury and damage to the implement or tractor.

**To attach the mower to the tractor do the following:**

1. Back the tractor up to the mower in order to slip the tractor hitch arms over the hitch pins welded to the mower hitch arms. **Turn off the tractor engine.** Secure them in place with the lynch pins.
2. Adjust the tractor sway blocks or chains to remove all side movement.
3. Attach the top link. Adjust tractor top link to allow the mower to follow the ground contour and yet remain as level as possible when raised to transport position.
4. Install the shielded driveline to the tractor by first lining up the splines and depressing the snap pin. Push the yoke onto the PTO shaft as far as it will go. Release the pin and pull back slowly until the pin clicks in place. Repeat this operation on the implement end.
5. Attach the driveline chains to the tractor and to the mower to keep the driveline protection from turning. The chains should not be too tight.

### 3.06 - Start Up



**DANGER:** The mower must always be lowered to the ground before starting tractor engine or engaging PTO lever.

Lower mower to the ground with the tractor rock shaft control lever. With the engine idling, slowly engage the PTO drive. Move the throttle lever until the PTO speed indicated on the mower is obtained.

The mower is set for a PTO speed of 540 rpm.

Shift the transmission to a slow speed gear and start forward, increase the ground speed by shifting upward until the desired speed is obtained. Do not mow in reverse unless absolutely necessary and only after careful observation of the area behind the mower.



**CAUTION:** Do not operate this mower at a PTO speed or direction of rotation other than that shown on the mower. Serious damage can occur to the machine and/or the operator.

Before starting to mow, never forget that the **operator is responsible** for the following:

1. Safe and correct driving of the tractor and mower.
2. To learn precise safe operating procedures for both the tractor and the mower.
3. To ensure all maintenance and lubrication has been performed on the mower.
4. To have read and understood all safety aspects for the mower in the operator's manual.
5. To have read and understood all safety decals on the mower.
6. Checking the condition of the blades. Worn or damaged blades should be changed before starting<sup>6</sup>.
7. Checking to ensure that the cutting edge is the leading edge of the blade<sup>7</sup>.
8. Checking that there is no wire, weed, grass or other material wrapped around blades.
9. Checking to see if front weights need to be added to the tractor in order to maintain balance.
10. Checking the tractor tires for the proper pressure in accordance with the tractor operator's manual.
- 11. Checking that the PTO shield, belt shields and all other shielding are on the machine and securely in place.**
12. Making sure the proper attire is worn. Avoiding loose fitting clothing which can become entangled. Wearing sturdy, tough-soled work shoes and protective equipment for eyes, hands, ears and head. Never operate tractor or implements in bare feet, sandals or sneakers.
13. Checking area for stones, branches and other debris that might be thrown.
14. Ensuring proper lighting is available, sunlight or good artificial lighting.

### 3.07 - Working Speed

The mowing speed depends on ground conditions, tractor HP, mowing height, and grass thickness. Only a test run will enable you to gauge the optimal working speed for your conditions.

Under most conditions a 3 to 8 mph ground speed is best. As a rule of thumb, and if the conditions permit, grass dispersion is increased by higher ground speeds.

In order to obtain the best cut possible, always keep the tractor rpm up to the speed indicated on the mower. When increasing or decreasing mowing ground speed, always use gear selection, not engine speed. This will maintain the constant maximum blade speed necessary for a clean cut.

The mulching kit is an option available for the GM1 mowers. This kit, containing 3 multilevel cutting edge blades and add-on containment baffling which bolts to the underside of the mower deck, mulches and pulverizes grass and leaves.

Another benefit of the mulching kit is safety. In fact, the kit greatly reduces the possibility of thrown objects. This is particularly important when mowing around schools, public parks and golf courses. If you are using a **mulching kit**, you need to reduce your ground speed to under 2 mph (**see fig. 9**).

---

<sup>6</sup> See Section 4.03 - Blade Maintenance.

<sup>7</sup> See Section 4.03 - Blade Maintenance.

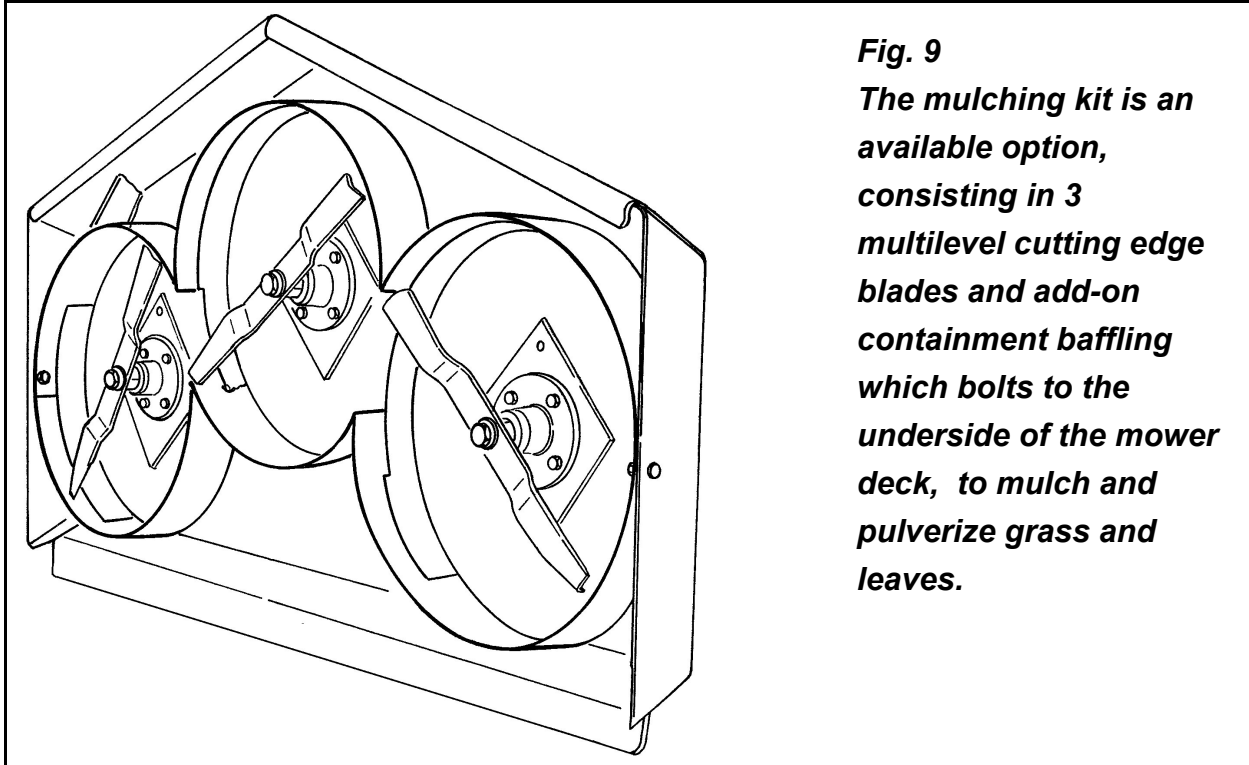

**Fig. 9**  
**The mulching kit is an available option, consisting in 3 multilevel cutting edge blades and add-on containment baffling which bolts to the underside of the mower deck, to mulch and pulverize grass and leaves.**

### 3.08 - Operating Techniques

All of the following factors are important in selecting the proper forward speed:

1. Height of grass.
2. Type of grass.
3. Density of grass.
4. Type of terrain.
5. Grass condition, wet or dry.

This mower has been designed to cut grass with heights from 4" to 8". It is recommended to avoid cutting grass taller than 10". For the best results, try cutting the grass at least once per week during growing season. Tall, dense grass should be cut at low speed, while thin medium grass can be cut at a faster ground speed. For cleaner cuts and efficient mowing, the blades must be kept sharp<sup>8</sup>.

Always operate PTO at 540 rpm. This is necessary to maintain proper blade speed and obtain a clean cut.

Under certain conditions, tractor tires may roll some grass down and prevent it from being cut at the same height as the surrounding area. If this occurs reduce the tractor ground speed but maintain a 540 rpm engine speed. The lower ground speed will permit the grass to at least partially rebound. Under some conditions grass will not rebound enough to be cut evenly, resulting in an uneven appearance. In general, lower cutting

<sup>8</sup> See Sharpening Blades in section 4.03 - Blade Maintenance.

height gives a more even cut with less tendency to leave tire tracks. If cut is still not satisfactory, cut the area twice.

Mow extremely tall grass twice. On the first pass use a high cutting height. On the second pass position the mower at the desired height and, when practical, mow at a right angle in travel to the first pass.

Plan your pattern to travel straight forward whenever possible.

It is better to cut grass more often, than too short. Short grass deteriorates rapidly in hot weather and invites weed growth during growing season.

If at any time the mower should jam resulting in belt slippage of 2 or more seconds, raise the mower and continue for 2-3 minutes. This will allow the pulleys to cool and prolong belt life.



**DANGER:** The mower blades can throw objects hundreds of feet which could result in personal or property damage.

**Pick up all rocks and other debris before mowing.**

**Enter new areas carefully. Cut grass higher at first, allowing mower to clear hidden objects.**



**CAUTION:** For emergency reasons learn how to stop the tractor and mower quickly. On the finishing mowers always disengage the PTO, lock parking brake, stop engine and allow the mower blades to come to a complete stop before dismounting the tractor.

### 3.09 - Uneven Terrain



**DANGER:** Be careful of rollover when operating tractor and mower over uneven ground.

The following precautions should always be observed when working on uneven terrain:

1. In extremely uneven terrain rear wheel weights, front tractor weights, and/or tire ballast should be used to improve stability.
2. Observe the type of terrain and develop a safe working pattern.
3. Whenever traction or stability is doubtful, first test drive over the terrain with the PTO disengaged.
4. Operate the implement up and down steep slopes, not across slopes, to prevent the tractor from tipping. Avoid sudden stops and starts, and slow down before changing directions on a slope.
5. Pass diagonally through sharp dips and avoid sharp drops to prevent hanging up the tractor and implement.

6. Slow down on sharp turns and slopes to prevent tipping or loss of control.
7. Avoid tipping the mower while cutting.
8. Watch for holes, roots or other hidden objects. Do not use near the edge of a gully, ditch or stream bank.

**An anti-scalping roller is recommended for uneven ground contours. The roller rides the nose of the mower over a mound to help keep the nose from bulldozing or the blades from scalping the ground.**

### 3.10 - Removing Mower from the Tractor



**CAUTION: Disengage tractor PTO. Set parking brake. Stop engine and remove key from ignition. Disconnect mower driveline from tractor PTO shaft. Collapse driveline and store in appropriate place. Disconnect three point linkage and carefully drive tractor away from mower.**

### 3.11 - Transport

Before raising the mower for transport, the tractor top link must be adjusted so when lifted, the rear of the machine is higher than the front (the mower's nose is tilted downward). To do this, shorten the tractor top link until the top hitch plate is locked forward and no longer able to pivot. This will keep the mower locked in position and minimize the shaking and bouncing during transport which can damage the hitch or frame.



**CAUTION: Make sure PTO is disengaged and blades have stopped turning before raising mower to full transport position. Do not tow tractor and mower behind other vehicles. Use a properly equipped trailer with heavy tie-downs for towing operations.**

Before transporting:

1. Always select a safe ground speed that is appropriate for the terrain.
2. Beware of traffic on public roads. Install a SMV (Slow Moving Vehicle) sign when traveling on roads or streets. Comply with all federal, state and local laws.
3. Reduce ground speed when turning and take care that the implement does not strike obstacles such as trees, fences or buildings.
4. Always disengage PTO before raising the implement to transport position.
5. When raising the mower be sure the PTO driveline does not hit either the mower or the tractor.
6. During transport the mower should not be lifted over 14" to 16" from the ground.

## 4 - MAINTENANCE



**DANGER:** Stop engine, lock parking brake and remove key before performing any service or maintenance.

Never rely on the tractor lift system. Install blocks or stands under the mower deck to prevent it from falling.

Always use personal protection devices, such as glasses or gloves when performing maintenance.

Keep fingers out of slots to prevent injury.

### 4.01 - Maintenance Safety



1. Good maintenance is your responsibility.
2. Keep service area clean and dry. Be sure electrical outlets and tools are properly grounded. Use adequate light for the job at hand.
3. Make sure there is plenty of ventilation. Never operate the engine of the towing vehicle in a closed building. The exhaust fumes may cause asphyxiation.
4. Make no repair or adjustments with the tractor engine running. Before working on the machine, disengage the PTO, shut off the engine, set the brakes, and remove the ignition key.
5. Be certain all moving parts on attachment have come to a complete stop before attempting to perform maintenance.
6. Never work under equipment unless it is blocked securely.
7. Always use personal protection devices such as eye, hand and hearing protectors, when performing any service or maintenance.
8. Frequently check mower blades. They should be sharp, free of nicks and cracks and securely fastened.
9. Periodically tighten all bolts, nuts and screws and check that all cotter pins are properly installed to ensure unit is in a safe condition.
10. When completing a maintenance or service function, make sure all safety shields and devices are installed before placing unit in service.
11. Do not attempt to mount a tire unless you have the proper equipment and experience to do the job.
12. Inflating or servicing tires can be dangerous. Whenever possible, trained personnel should be called to service and/or mount tires.
13. After servicing, be sure all tools, parts and service equipment are removed.



14. Never replace hex bolts with less than grade five bolts unless otherwise specified, i.e. shear bolts<sup>9</sup>.
15. Where replacement parts are necessary for periodic maintenance and servicing, genuine replacement parts must be used to restore your equipment to original specifications. The company will not claim responsibility for use of unapproved parts and/or accessories and other damages as a result of their use.
16. Unauthorized modifications to the machine may impair the function and/or safety of the machine and reduce its life. If equipment has been altered in any way from original design, the manufacturer does not accept any liability for injury or warranty.

## 4.02 - Service

The accompanying illustrations show lubrication points. The chart gives the frequency of lubrication in hours, based on normal operating conditions. Severe or unusual conditions may require more frequent lubrication.

Use a good quality SAE multipurpose type grease for all locations shown. Be sure to clean fittings thoroughly before using grease gun.

Use 90 wt. gear oil in gearbox.

### Hourly:

1. Check the condition of mower blades for nicks or dull edges. Sharpen if necessary.
2. Replace bent or damaged blades<sup>10</sup>.
3. Also check blades for damage after hitting an obstruction.
4. Clean foreign material from mower deck and belt area.

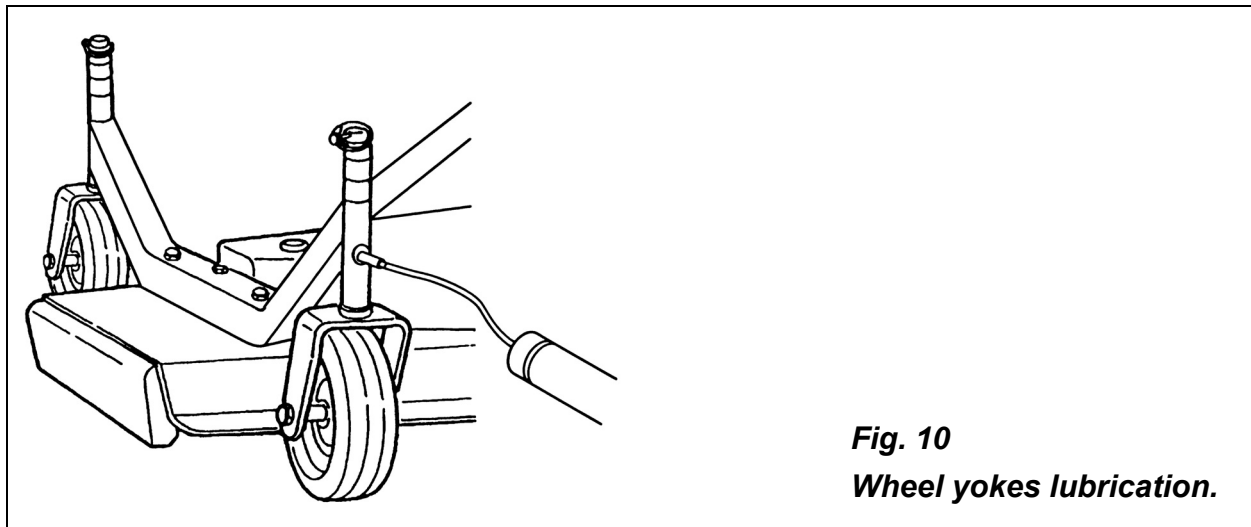

**Fig. 10**  
**Wheel yokes lubrication.**

### Every 8 hours:

1. **Lubricate the driveline and the wheel yokes:** Apply two or three shots of grease to the driveline cross and bearings and the telescoping shafts; apply the same

<sup>9</sup> Refer to Table 1 - Torque Specifications, page 32.

<sup>10</sup> See Section 4.03 - Blade Maintenance.

amount to the wheel arm grease fittings (**see fig. 10**). See the driveline manufacturer operator's manual for further information on the driveline.

2. **Gearbox oil level:** Check gearbox oil level, it should be between  $\frac{1}{2}$  and  $\frac{2}{3}$  full. If needed add either SAE 90 wt. or SAE 140 wt. gear oil.

**Every 25 hours: Check hardware tightness;** mower vibrations can loosen bolts. Check tightness of the hardware periodically, using Table 1 as a guide<sup>11</sup>.

**Every 50 hours:**

1. Lubricate the three spindles with two or three shots of multipurpose grease (**see fig. 11**). The top grease fittings are easily accessible from the top of the deck by simply removing the plastic dust guards.
2. Check belt tension<sup>12</sup>.

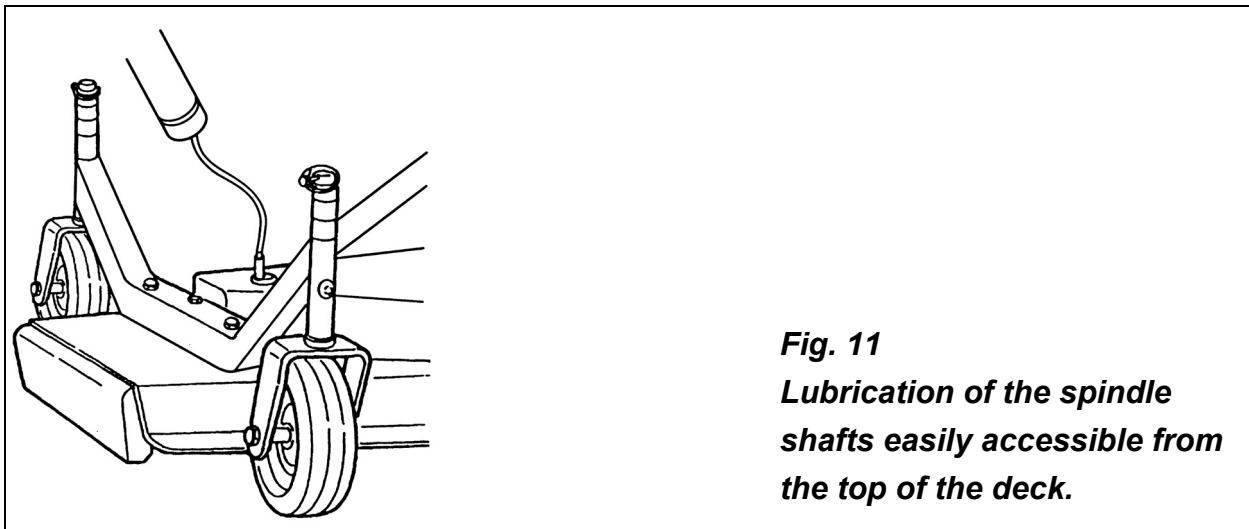

**Fig. 11**  
**Lubrication of the spindle shafts easily accessible from the top of the deck.**

## 4.03 - Blade Maintenance



**WARNING:** To avoid possible injury always wear proper eye and hand protection when servicing mower blade.

In order for the mower to work properly, and to always obtain a precision cut with lower HP requirements thus keeping cost down, proper blade maintenance is important. Blades must be kept sharp, at their original length and corners maintained. A blade must be replaced if, due to wear or damage, its original shape has been distorted.

<sup>11</sup> See Table 1 - Torque Specifications, page 32.

<sup>12</sup> See Section 4.04 - Belt Tension.

### Installing or removing blades

If the mower blades need to be installed, do the following:

1. The blade turns in a **counter clockwise** direction when viewed from the bottom of the deck. The cutting edge must be towards the direction of rotation. The lift wing of the blades is closest to the deck and the cutting edge away from it (**see fig. 12**).
2. Install the cup washer (**see fig. 12**) over the blade bolt and secure the blade in place as described above.
3. With a wrench, block the spindle and tighten the bolt to 103 lb. ft. (**see fig. 13**).
4. To remove the blades reverse the procedure.

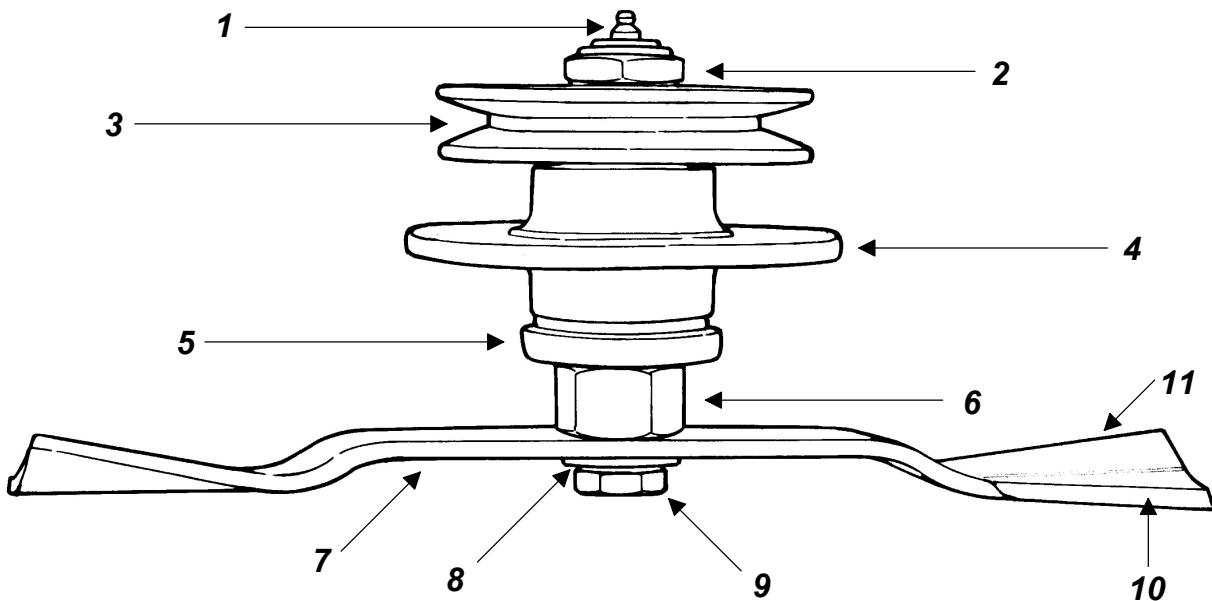

**Fig. 12 - Spindle assembly.**

1. grease fitting
2. hexagonal nut
3. pulley
4. rotor support
5. cover
6. shaft

7. blade
8. cup washer
9. blade bolt
10. cutting edge close to ground
11. lift wing

Ground



**WARNING:** Do not substitute blades or any bolt for the blade retaining bolt. Company blades and blade retaining bolts are specially made for this application. Using non original parts can effect the quality of cut and may also cause damage to the mower.



**DANGER:** Proper torque must be used when tightening the blade retaining bolt. If these safety precautions are not followed, the blade could come off during operation and be thrown hundreds of feet from the mower.

### Sharpening Blades

Blade sharpening is extremely important in order to get the best cutting results. Sharp blades permit a high quality cut and also reduce HP thus lowering cost.

To sharpen blades, first remove them following the above instructions.

Place the blade in a vise and sharpen them by using a hand file or grinder. **Do not sharpen the blades to a sharp cutting edge.** The cutting edge should be between  $\frac{1}{64}$ " to  $\frac{1}{32}$ " to prevent excessive pitting and dulling of the blades. Sharpen both ends of the blade equally for balance and always maintain corners. Always keep all three blades sharpened equally in order to maintain balance.

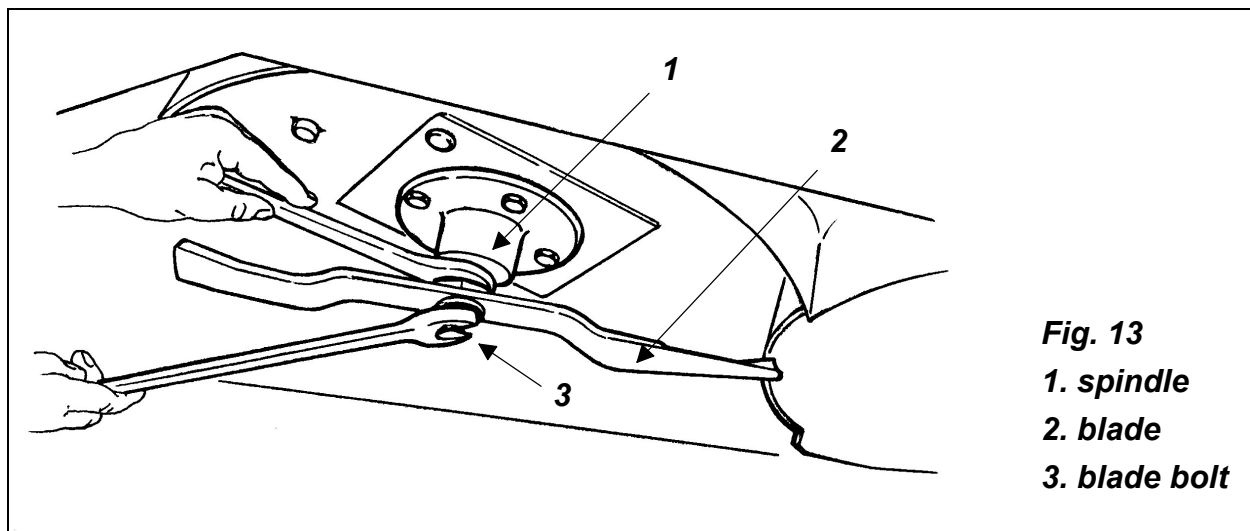

**Fig. 13**  
 1. spindle  
 2. blade  
 3. blade bolt



**CAUTION:** Unbalanced or warped blades can cause damage to the mower and/or personal injury. Replace damaged blades before operating the mower. Sharpen both ends of the mower blades equally or until the blade is balanced.

## 4.04 - Belt Tension

### Belt tension control

Check the belt tension by applying a force of 12-15 lb. pushing against the belt halfway between the pulleys. The belt deflection should be between  $\frac{5}{16}$ " -  $\frac{3}{8}$ ".

### Belt tension adjustment

The mower has an automatic belt tensioner. The tension is created by a spring connecting a tensioner pulley to a fixed hitch plate with 3 positions (see fig. 14). Upon delivery, the spring is located in the first position. When the belt stretches after use, adjust the tension by relocating the spring in the other two holes. If the belt has stretched to the point that the belt is not tight enough even in the last hole, then it is necessary to replace the belt.

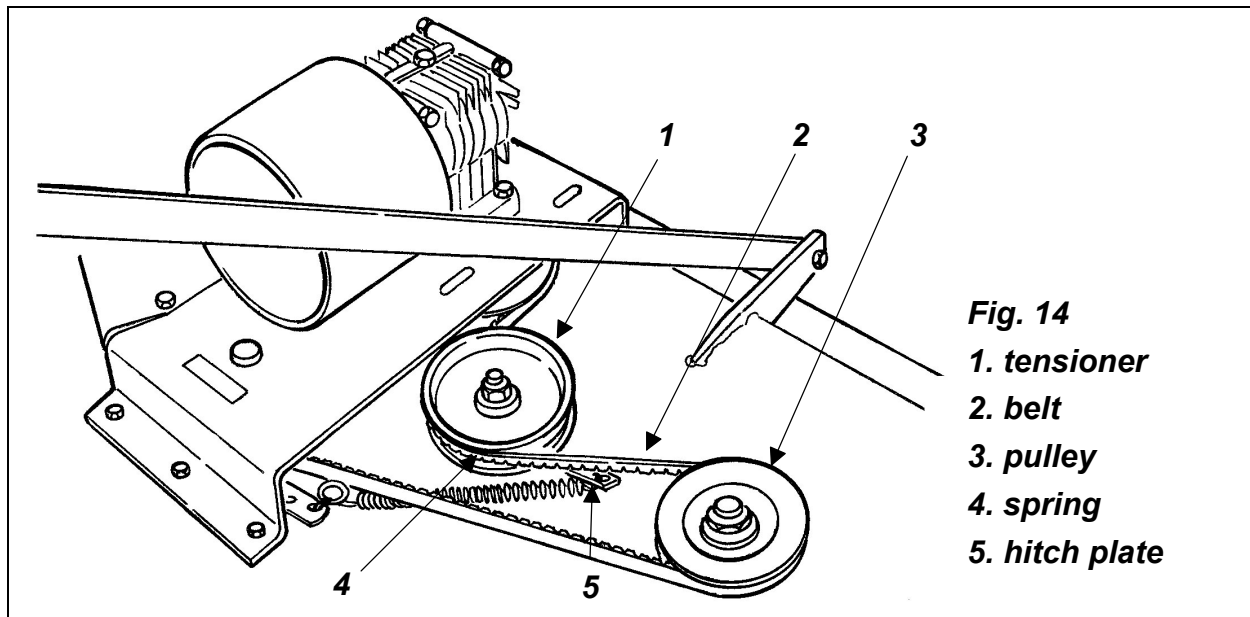
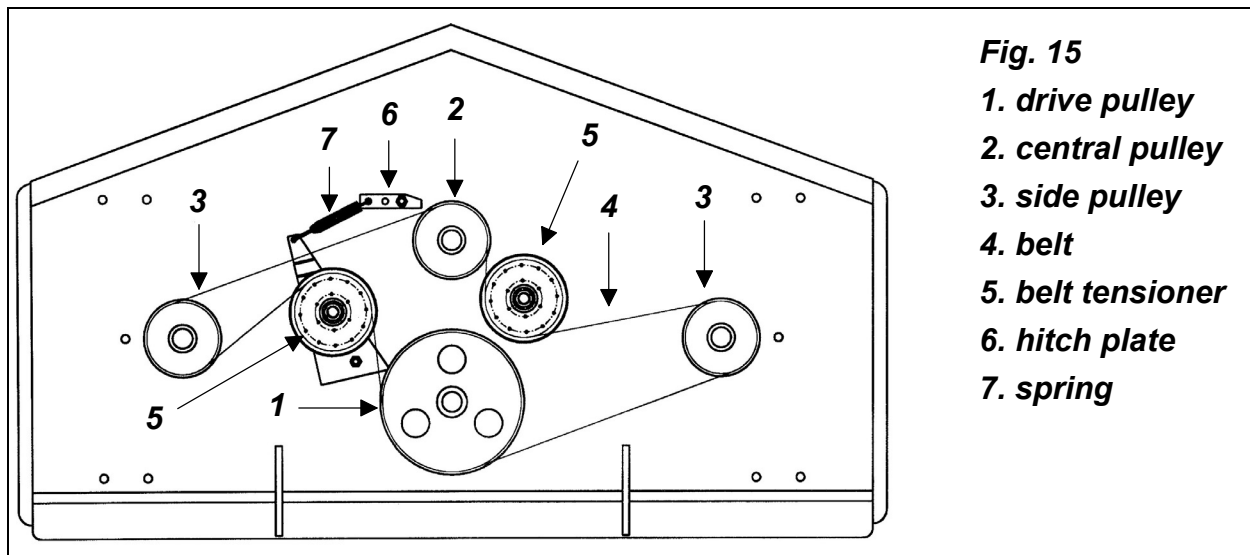

**Fig. 14**

- 1. tensioner
- 2. belt
- 3. pulley
- 4. spring
- 5. hitch plate

### 4.05 - Belt Replacement

If the belt has been stretched or damaged to the point where the proper tension cannot be obtained it must be changed.



**Fig. 15**

- 1. drive pulley
- 2. central pulley
- 3. side pulley
- 4. belt
- 5. belt tensioner
- 6. hitch plate
- 7. spring

To replace the belt do the following:

1. Remove belt shields. Clean foreign material from the mower deck and belt area.
2. Release spring tensioner to loosen belt.
3. Loosen rear nuts holding central plate (do not remove them).
4. Remove front nuts holding central plate (**see fig. 14**).
5. Lift the front of the central plate and remove old belt.
6. Replace new belt starting from the right spindle pulley (**see fig. 15**).
7. Lower central plate. Replace front nuts. Tighten front and rear nuts holding down central plate.
8. Replace spring tensioner.
9. Check belt for proper tension.
10. Reinstall the belt shields.

## 4.06 - Driveline



**DANGER:** Only use the original driveline supplied with this mower and always with the safety shielding. Carefully read and file away the driveline operator's manual supplied by the manufacturer. The following does not substitute the information found in the driveline manual.

**IMPORTANT:** Always check driveline length during initial setup and when connecting to a different tractor.

In the collapsed position the driveline should be approximately 2" from bottoming out to prevent possible damage to the tractor or implement. When the driveline is in the maximum extended position, the ideal minimum overlap of the two halves should be approximately 6" (**see fig. 16**).

**Fig. 16**

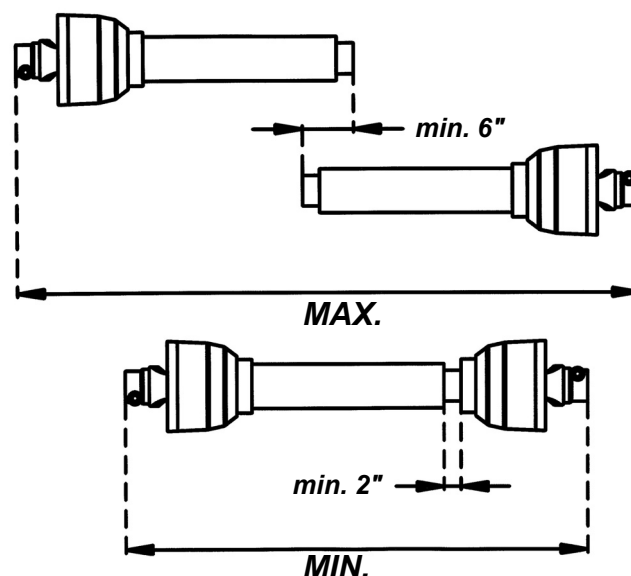

If determined that the driveline is too long, follow these procedures to adjust the length:







1. Separate the two driveline halves. Connect one half to the tractor PTO and the other half to the mower.
2. Raise and lower the mower with the 3 point hitch to find the position where the driveline is shortest. Hold the half shafts side by side and mark the desired length on the outer female tube guard leaving a 1½" gap between the end of the guard tube and bell guard.
3. Cut off both guard tubes the same amount as marked in step 2.
4. Shorten both drive tubes the same amount as guard tubes.
5. De-burr and clean filings from drive tubes and apply grease to outside of inner telescoping tube.
6. Reassemble the driveline halves and connect to tractor and mower. Raise and lower mower again to be sure driveline does not bottom out in its shortest position and has a minimum overlap of 6" in the longest position.
7. Install both driveline safety chains. One should be hooked in a hole on the outer driveline yoke shield and to the tractor to restrict outer shield rotation. The second one should be hooked in a hole on the inner driveline yoke shield and to the implement to restrict inner shield rotation.

If determined that the driveline is too short for your tractor, contact your local dealer.



**CAUTION:** Always work with the driveline as straight as possible. This will prolong its life and that of its components. It is advised, not to work at an angle greater than 15 degrees.

**TABLE 1 - TORQUE SPECIFICATIONS**

Metric (ISO) treaded bolts head marking							Inch (SAE) treaded bolts head marking								
	Class 5.8		Class 8.8		Class 10.9			Grade 2		Grade 5		Grade 8			
Bolt size mm	Thread mm	N.m	ft-lb	N.m	ft-lb	N.m	ft-lb	Bolt size inch	Thread inch tpi	N.m	ft-lb	N.m	ft-lb	N.m	ft-lb
M5	0.8	4	3	6	4	9	7	1/4"	20	7	5	11	8	16	12
M6	1	6	4	10	7	15	11	1/4"	28	8	6	13	10	19	14
M8	1.25	16	12	25	18	36	27	5/16"	18	15	11	24	17	33	25
M8	1	17	13	26	19	38	28	5/16"	24	17	13	26	19	37	27
M10	1.5	31	23	48	35	71	52	3/8"	16	27	20	42	31	59	44
M10	1.25	33	24	51	38	75	55	3/8"	24	31	23	47	35	67	49
M10	1	35	26	53	39	78	58	7/16"	14	43	32	67	49	95	70
M12	1.75	54	40	84	62	123	91	7/16"	20	48	36	75	55	106	78
M12	1.5	56	41	87	64	128	94	1/2"	13	66	48	102	75	144	106
M12	1.25	59	44	90	66	133	98	1/2"	20	75	55	115	85	163	120
M14	2	84	62	133	98	195	144	9/16"	12	95	70	147	109	208	154
M14	1.5	94	69	142	105	209	154	9/16"	18	106	79	164	121	232	171
M16	2	131	97	206	152	302	223	5/8"	11	132	97	203	150	287	212
M16	1.5	141	104	218	161	320	236	5/8"	18	149	110	230	170	325	240
M18	2.5	181	133	295	218	421	310	3/4"	10	233	172	361	266	509	376
M18	2	196	145	311	229	443	327	3/4"	16	261	192	403	297	569	420
M18	1.5	203	150	327	241	465	343	7/8"	9	226	167	582	430	822	606
M20	2.5	256	189	415	306	592	437	7/8"	14	249	184	642	473	906	668
M20	1.5	288	212	454	335	646	476	1"	8	339	250	873	644	1232	909
M22	2.5	344	254	567	418	807	595	1"	12	371	273	955	704	1348	995
M22	1.5	381	281	613	452	873	644	1-1/8"	7	480	354	1077	794	1746	1288
M24	3	444	327	714	526	1017	750	1-1/8"	12	539	397	1208	891	1958	1445
M24	2	488	360	769	567	1095	808	1-1/4"	7	677	500	1519	1120	2463	1817
M27	3	656	484	1050	774	1496	1103	1-1/4"	12	750	553	1682	1241	2728	2012
M27	2	719	530	1119	825	1594	1176	1-3/8"	6	888	655	1992	1469	3230	2382
M30	3.5	906	668	1420	1047	2033	1499	1-3/8"	12	1011	746	2268	1673	3677	2712
M30	2	1000	738	1600	1180	2250	1659	1-1/2"	6	1179	869	2643	1949	4286	3161
M36	4	1534	1131	2482	1830	3535	2607	1-1/2"	12	1326	978	2974	2194	4823	3557

When using lock washers with nuts, increase torque values by 5%.

**TABLE 2 - GM1 GROOMING MOWERS - TECHNICAL FEATURES**

Series GM1, Rear Discharge, for tractors up to 30 HP, PTO 540 rpm, 3 point hitch cat. 1											
Model	HP	Working width	Overall width	Weight lb.	Rotor rpm/min	Blades tip speed ft/min	# Blades	Cutting height	# Belts & type	# Wheels & size	Driveline 1 3/8"
GM1048E	16-30	48"	51"	340	3,037	13,188	3	1" - 4"	1 BX	4 - 8.4"x3.2"	ASAE 2 <sup>nd</sup> . cat
GM1060E	16-30	60"	62"	375	2,803	14,763	3	1" - 4"	1 BX	4 - 8.4"x3.2"	ASAE 2 <sup>nd</sup> . cat
GM1072E	16-30	72"	74"	440	2,278	14,566	3	1" - 4"	1 BX	4 - 8.4"x3.2"	ASAE 2 <sup>nd</sup> . cat



## 5 - REPAIR PROCEDURES



**CAUTION:** All repair procedures must be done by authorized dealerships. It is not recommended that untrained individuals perform any repair work. The following operations are detailed for qualified personnel only.

### 5.01 - Gearbox

To remove the gearbox:

1. Remove the belt<sup>13</sup> (see fig. 14).
2. Remove the nut holding the pulley to the gearbox pinion shaft.
3. Remove the pulley.
4. Remove the nuts holding the gearbox to the central plate.
5. Remove the gearbox.

If it is necessary to replace any part on the inside of the gearbox, it is important to replace oil seals or gaskets to ensure a tight fit when reassembling.

To replace the gearbox, follow the above instructions in reverse order.

### 5.02 - Blade Spindle

To remove a blade spindle:

1. Remove the belt<sup>14</sup>.
2. Remove the nut holding the pulley to the spindle shaft (see fig. 12).
3. Remove the blades<sup>15</sup>.
4. Unbolt the bolts holding the rotor support to the mower deck.
5. If necessary remove and replace the bearings from the rotor using presses or extractors.
6. Reassemble in reverse order **ensuring that the nut securing the top pulley (see fig. 12) is tightened to 118 lb. ft.**

### 5.03 - Suggested Spare Parts

It is suggested that the following spare parts be kept on hand for the mower at all times to prevent a minor problem from delaying work.

---

<sup>13</sup> See Section 4.05 - Belt Replacement.

<sup>14</sup> See Section 4.05 - Belt Replacement.

<sup>15</sup> See Section 4.03 - Blade Maintenance.

Description	Quantity
Blades	3
Blade bolts	3
Washers	3
Belts	1

### 5.04 - Storage

After seasonal use it is important to perform the following for prolonged storage:

1. Wash the mower carefully.
2. Inspect the mower and replace worn or damaged parts.
3. Tighten all hardware.
4. Grease all areas indicated under Maintenance<sup>16</sup>.
5. Loosen the belts if the mower is to be stored for an extended length of time.
6. Cover the mower from the elements in order to have it in perfect condition for the start of the next season.

---

<sup>16</sup> See Chapter 4 - Maintenance.

## 6 - TROUBLESHOOTING



**WARNING:** Be sure tractor engine is off, parking brake is locked, and key is removed before making any adjustments.

PROBLEM	POSSIBLE CAUSE	SOLUTION
Uneven cutting.	Cup washer not between blade and bolt. Ground speed too fast. Blades need sharpening. Caster wheels uneven.	Check washer location at all 3 spindles. Shift to lower gear. Sharpen blades. Adjust wheel position.
Blades turning but not cutting.	Direction of blades is wrong.	Blade should turn CCW when you face deck bottom. See Blades Maintenance section.
Belt slippage.	Lack of tension. Object clogging mower. Debris in pulleys.	Tighten belt. Remove object. Clean pulleys.
Mower vibrates.	Object wrapped around blade. Belt damaged.	Remove object. Replace belt.
Belt squeal.	Belt slipping.	Tighten belt.
Grass build up at exit.	Wet grass. Grass too high.  Tractor rpm too slow.	Allow grass to dry. Raise mower, shift to lower gear, make two passes over grass. Mow grass high 1st pass, 2nd pass cut to desired height. Increase tractor rpm, check engine and PTO speeds.
Belts are tight when installing.	Wrong belt size. Installed belts incorrectly.	Check belt size. See Belts Replacement section.
Streaking conditions in swath.	Too wet to mow. Blades cannot cut grass pressed down by wheels. Dull blades.  Blades worn down, preventing overlap.	Allow grass to dry. Maintain engine speed and shift to lower gear. Sharpen blade. See Blades Maintenance section. Change blades.
Cut grass windrows.	Ground speed too low. Tractor rpm too slow.	Increase ground speed. Increase tractor rpm, check engine and PTO speeds.

## 7 - PRE-DELIVERY CHECKLIST

**To the dealer: Inspect the machine thoroughly after assembly to assure it is functioning properly before delivering it to the customer. The following checklist is a reminder of points to cover. Check off each item as it is found satisfactory or after proper adjustment is made.**

- Gearbox oil level.
- Guards and shield properly fastened.
- Lubrication of grease fittings.
- All hardware properly tightened.
- All decals properly located and readable (**see fig. 5**).
- Blades properly installed, blade bolts and nuts tightened.
- Overall condition (touch up scratches, clean and polish).
- Test run, check for excessive vibration or overheating of bearings.
- Operator's Manual.

**Review the Operator's Manual with the customer. Explain the following:**

- Warranty.
- Safe operation and service.
- Correct machine installation and operation.
- Daily and periodic lubrication, maintenance and inspections.
- Troubleshooting.
- Operational procedures and storage.
- Parts and service.
- Fill out the Pre-Delivery Checklist and the on-line Warranty Registration form.
- Give customer the Operator's Manual and encourage the customer to read the manual carefully.

**IMPORTANT: The dealer must complete the Warranty Registration, located on the Frontier website. Warranty claims will be denied if the Warranty Registration has not been completed.**

Model Number: \_\_\_\_\_

Serial Number: \_\_\_\_\_

Delivery Date: \_\_\_\_\_

Dealer's Signature: \_\_\_\_\_

# GROOMING MOWERS

**GM1048E**

**GM1060E**

**GM1072E**

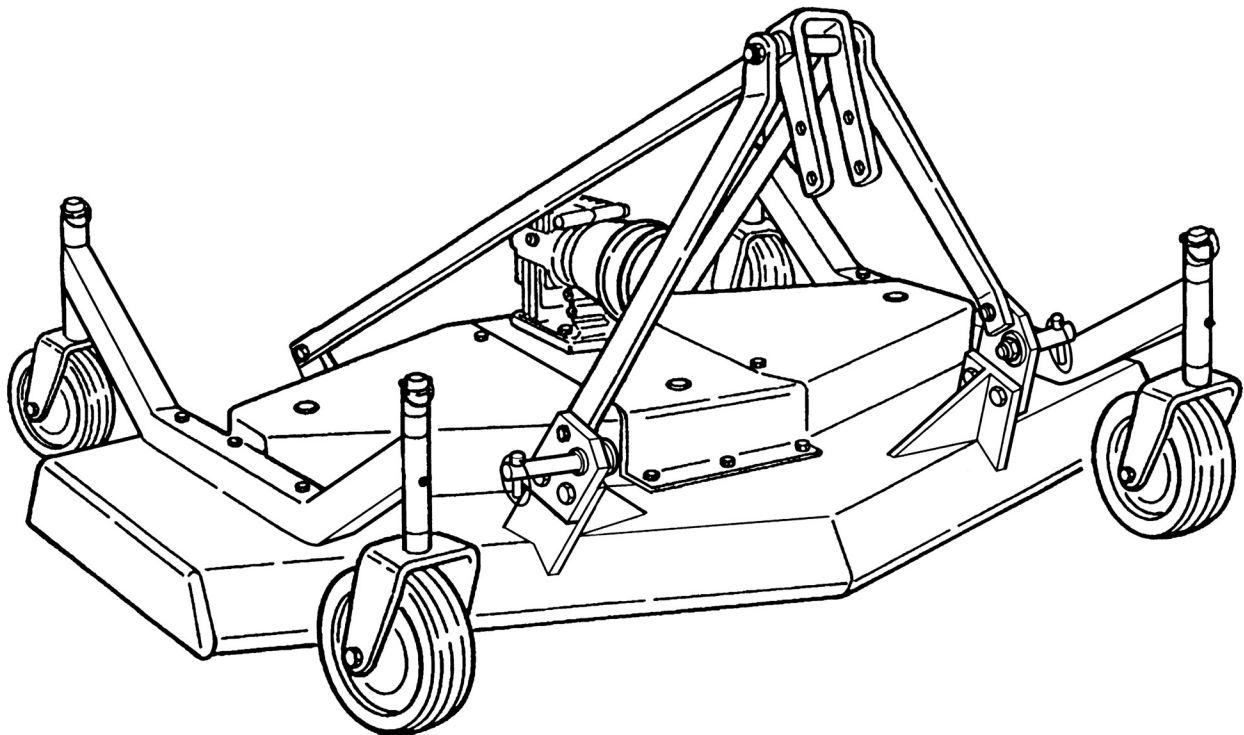

**Note: Serial #'s with the XF prefix are subsequent to serial numbers with the BC prefix. For example: A reference to "serial # BC... 739197 & above" will also include all serial numbers with an XF prefix.**

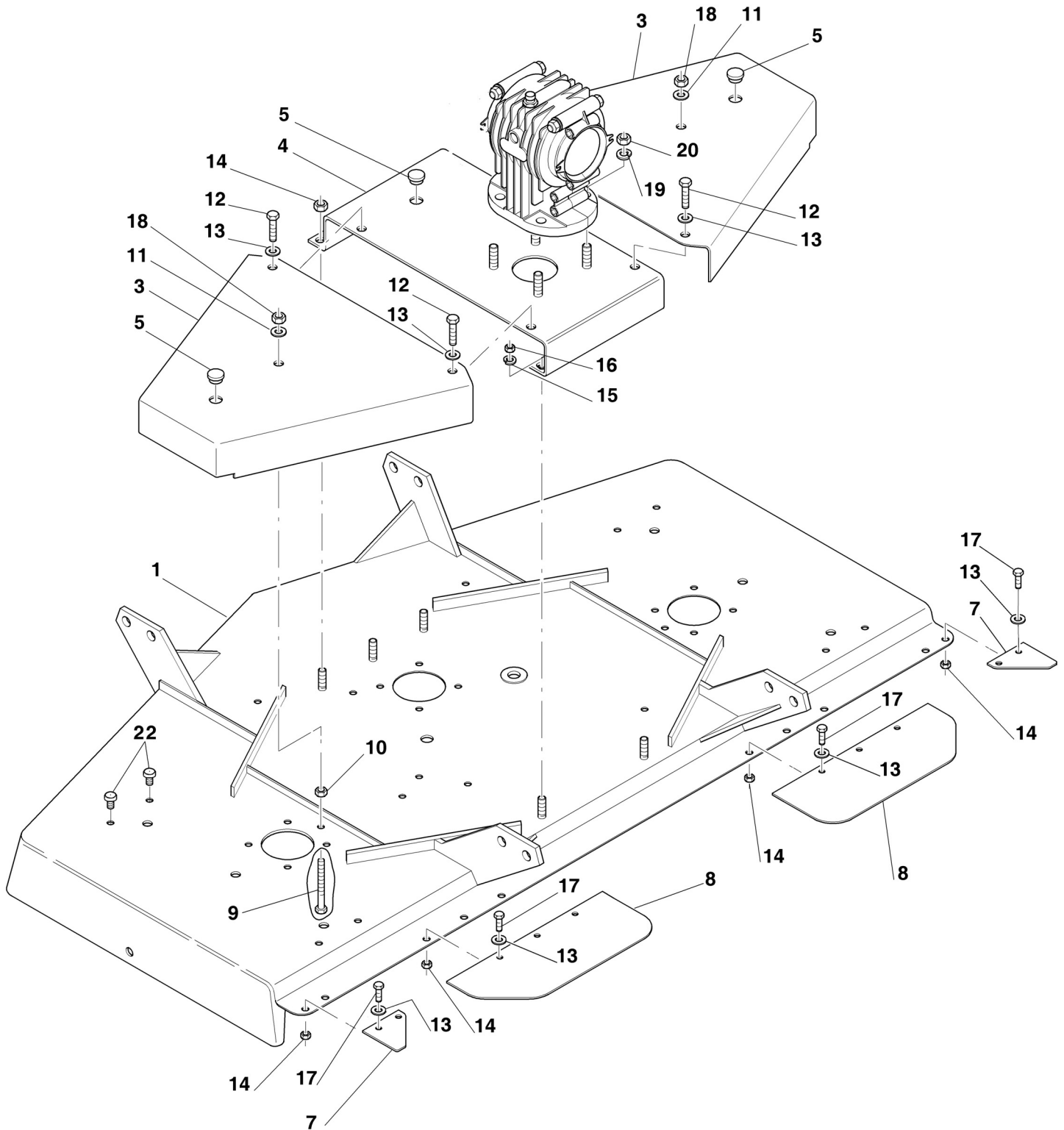

Ref.	Part #	Description	Qty.
1	5BP0151501P	Frame 4' rear discharge; GM1048E #BC...844971 & above <sup>17</sup>	1
	5BP0251501P	Frame 5' rear discharge; GM1060E #BC...844971 & above <sup>18</sup>	1
	5BP0351501P	Frame 6' rear discharge; GM1072E #BC...844971 & above <sup>19</sup>	1
3	5BP0108817	Belt shield 4' frame; GM1048E	2
	5BP0208817	Belt shield 5' frame; GM1060E	2
	5BP0308817	Belt shield 6' frame; GM1072E	2
4	5BP0051581	Central plate 4' frame; GM1048E	1
	5BP0051583	Central plate 5' frame; GM1060E	1
	5BP0051585	Central plate 6' frame; GM1072E	1
5	5BP0006647	Cap	3
7	5BP0051858	Rear protection 5' frame, outer; GM1060E	2
	5BP0051859	Rear protection 6' frame, outer; GM1072E	2
8	5BP0051856	Rear protection, inner	2
9	5BP0008818	Bolt HH M10-1.50x110 C8.8 Z F	2
10	5BP0014106	Nut ES M10-1.50 Z TK	2
11	5BP0030157	Washer fender Ø10 Z	-
12	5BP0033176	Bolt HH M10-1.50x25 C8.8 Z F	-
13	5BP0002034	Washer flat Ø10 W	-
14	5BP0030156	Nut PT M10-1.50 C6 TK Z	-
15	5BP0001280	Washer lock Ø10 Z	2
16	5BP0001279	Nut HH M10-1.50 C6 TK Z	4
17	5BP0006349	Bolt HH M10-1.50x20 C8.8 Z F	-
18	5BP0015237	Nut ES M10-1.50 Z TN	2
19	5BP0001077	Washer lock Ø12 Z	4
20	5BP0003038	Nut HH M12-1.75 C6 Z TK	4
22	5BP0051570	Cap	-

<sup>17</sup> Serial #BC...844970 & below must also order two (2) linking plates (5BP0051817) when replacing frame.

<sup>18</sup> Serial #BC...844970 & below must also order two (2) linking plates (5BP0051817) when replacing frame.

Serial #BC...307418 & below must also order two (2) linking plates (5BP0051817) & two (2) belt shields (5BP0208817) when replacing frame.

<sup>19</sup> Serial #BC...844970 & below must also order two (2) linking plates (5BP0051817) when replacing frame.

Serial #BC...307418 & below must also order two (2) linking plates (5BP0051817) & two belt (2) shields (5BP0308817) when replacing frame.

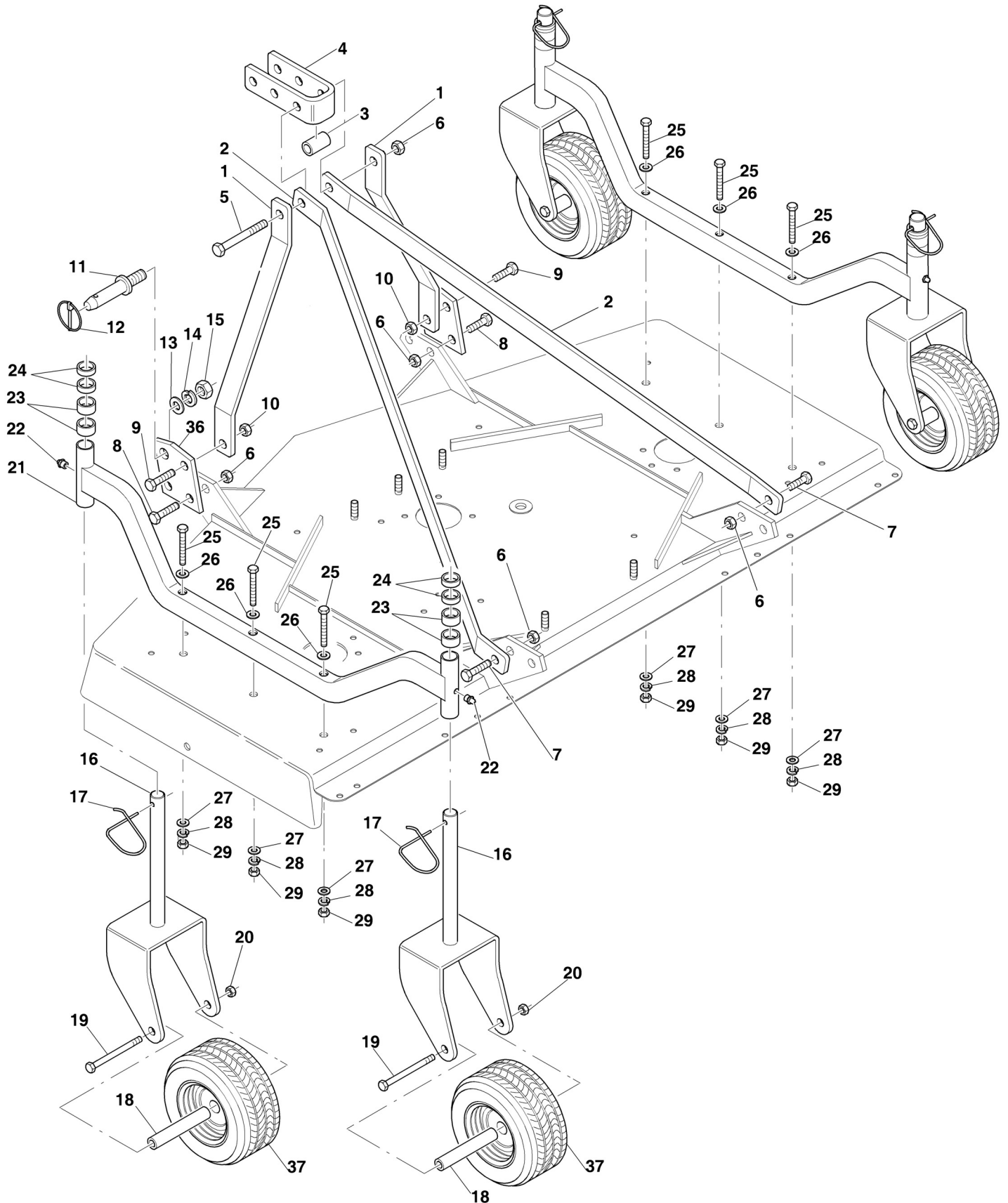



Ref.	Part #	Description	Qty.
1	5BP0051822	Top hitch support	2
2	5BP0051824	Top hitch arm GM1048E	2
	5BP0051826	Top hitch arm GM1060E	2
	5BP0051828	Top hitch arm GM1072E	2
3	5BP0006829	Spacer	1
4	5BP0006828	Top hitch plate	1
5	5BP0006891	Bolt HH M16-2.00x140 C8.8 Z P	1
6	5BP0005581	Nut PT M16-2.00 C6 Z TK	7
7	5BP0032687	Bolt HH M16-2.00x40 C8.8 Z F	2
8	5BP0006578	Bolt HH M16-2.00x45 C8.8 Z F	4
9	5BP0009538	Bolt HH M20-2.50x45 C8.8 Z F	2
10	5BP0005507	Nut PT M20-2.50 C6 TK Z	2
11	5BP0005550	Hitch pin	2
12	5BP0018266	Lynch pin Ø11x45	2
13	5BP0051849	Spacing disc	2
14	5BP0005351	Washer lock Ø20 Z	2
15	5BP0005542	Nut HH M20-1.50 C6 Z MD	2
16	5BP0008785	Wheel yoke	4
17	5BP0008783	Cotter pin	4
18	5BP0008528	Spacer	4
19	5BP0006615	Bolt HH M14-2.00x140 C8.8 Z P	4
20	5BP0030358	Nut PT M14-2.00 C6 Z TK	4
21	5BP0051772	Wheel arm 4' frame; GM1048E	2
	5BP0051781	Wheel arm 5' frame; GM1060E	2
	5BP0051783	Wheel arm 6' frame; GM1072E	2
22	5BP0001065	Grease fitting M10-1.00	4
23	5BP0006586	Spacer, height adjustment 1"	8
24	5BP0006587	Spacer, height adjustment ½"	8
25	5BP0026185	BOLT HH M10-1.50x90 C8.8 Z P	6
26	5BP0051776	Washer flat SP Ø10 W	6
27	5BP0002034	Washer flat Ø10 W	6
28	5BP0001280	Washer lock Ø10 Z	6
29	5BP0001279	Nut HH M10-1.50 C6 TK Z	6
36	5BP0051817	Linking plate, #BC...844971 & above	2
37	5BP0008526	Wheel hard tire, complete	4
	5BP0006613	Bushing, hard tire (not shown)	8
	5BP0008797	Wheel 9" air tire, complete (option)	4
	5BP0006969A	Steel retainer, air tire (not shown)	8
	5BP0006968	Bearing needle, air tire (not shown)	8

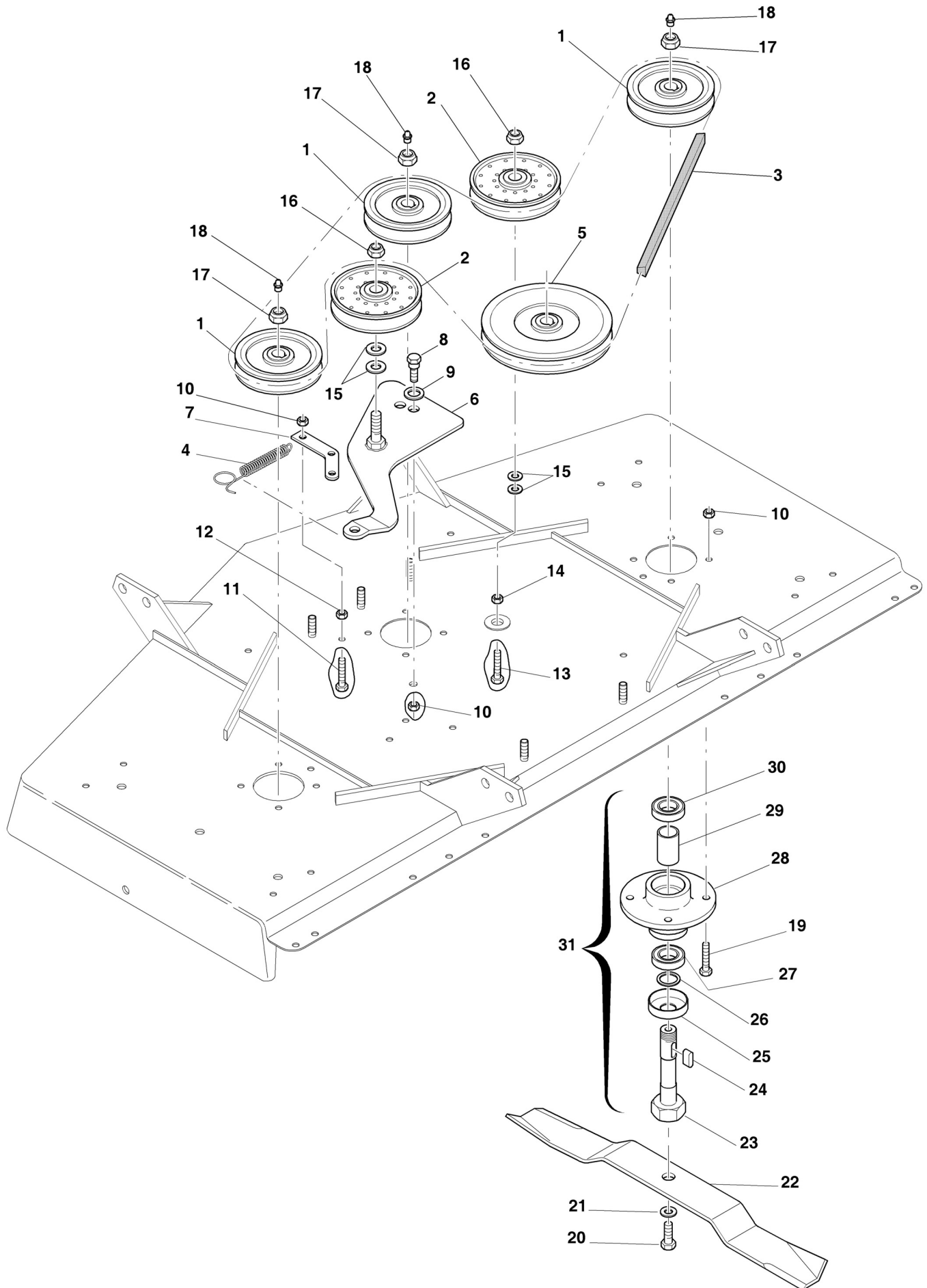

Ref.	Part #	Description	Qty.
1	5BP0008531	Pulley SPB 120x1; GM1048E	3
	5BP0008666	Pulley SPB 130x1; GM1060E	3
	5BP0008881	Pulley SPB 160x1; GM1072E	3
2	5BP0008561	Pulley, belt tensioner	2
3	5BP0008630	Belt BX 98; GM1048E	1
	5BP0008670	Belt BX 112 ½; GM1060E	1
	5BP0008950	Belt BX 140; GM1072E	1
4	5BP0051740	Spring	1
5	5BP0008623	Pulley SPB 250x1	1
6	5BP0008563	Support, belt tensioner; #BC...631791 & below	1
	5BP0051741	Support, belt tensioner; GM1048E #BC...631792 & above	1
	5BP0051745	Support, belt tensioner; GM1060E, GM1072E #BC...631792 & above	1
7	5BP0008571	Hitch plate; #BC...631791 & below	1
	5BP0008571	Hitch plate; GM1048E #BC...631792 & above	1
	5BP0051755	Hitch plate; GM1060E #BC...631792 & above	1
	5BP0051757	Hitch plate; GM1072E #BC...631792 & above	1
8	5BP0091281	Bolt HH M10-1.50x35 C8.8 Z F; #BC...631791 & below	1
	5BP0051751	Bolt belt tensioner SP M10-1.50; #BC...631792 & above	1
9	5BP0030157	Washer fender Ø10 Z; #BC...631791 & below	1
	5BP0051753	Washer flat Ø16 W; #BC...631792 & above	1
10	5BP0030156	Nut PT M10-1.50 C6 TK Z	14
11	5BP0091281	Bolt HH M10-1.50x35 C8.8 Z F	1
12	5BP0001279	Nut HH M10-1.50 C6 TK Z	1
13	5BP0008576	Bolt HH M20-2.50x65 C8.8 Z F	1
14	5BP0005508	Nut HH M20-2.50 C6 Z MD	1
15	5BP0046555	Washer flat Ø20 Z	4
16	5BP0005507	Nut PT M20-2.50 C6 TK Z	2
17	5BP0006698	Nut SP M25-1.50 Z	3
18	5BP0029036	Grease fitting Ø8, press in	3
19	5BP0001278	Bolt HH M10-1.50x30 C8.8 Z F	12
20	5BP0006659	Bolt blade SP M14-1.50x32	3
21	5BP0008560	Washer conical spring Ø18 Z	3
22	5BP0006795	Blade standard 4' frame; GM1048E	3
	5BP0006641	Blade standard 5' frame; GM1060E	3
	5BP0006845	Blade standard 6' frame; GM1072E	3
	5BP0006795M	Blade mulching 4' frame; GM1048E (option)	3
	5BP0006641M	Blade mulching 5' frame; GM1060E (option)	3
	5BP0006845M	Blade mulching 6' frame; GM1072E (option)	3
	5BP0006795B	Blade high lift 4' frame; GM1048E (option)	3
	5BP0006641B	Blade high lift 5' frame; GM1060E (option)	3
	5BP0006845B	Blade high lift 6' frame; GM1072E (option)	3
	5BP0006795F	Blade flat 4' frame; GM1048E (option)	3
	5BP0006641F	Blade flat 5' frame; GM1060E (option)	3
	5BP0006845F	Blade flat 6' frame; GM1072E (option)	3
	5BP0006795G	Blade gator 4' frame; GM1048E (option)	3
	5BP0006641G	Blade gator 5' frame; GM1060E (option)	3
	5BP0006845G	Blade gator 6' frame; GM1072E (option)	3

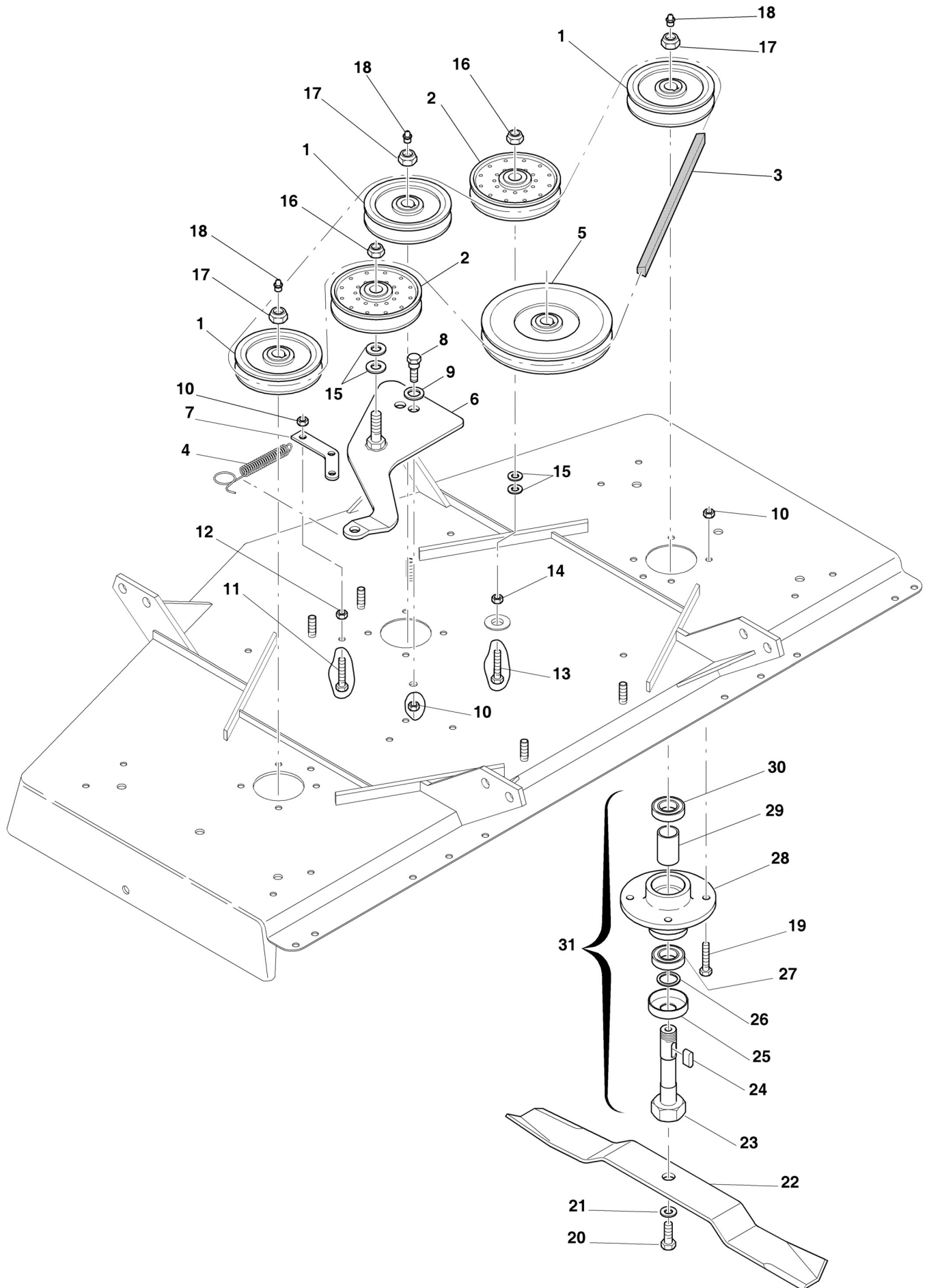

Ref.	Part #	Description	Qty.
23	5BP0008557	Spindle shaft	3
24	5BP0006639	Key 8x7x25	3
25	5BP0006636	Cover	3
26	5BP0006606	Shim Ø25x35x2	3
27	5BP0006626A	Bearing 6205-ZZ	3
28	5BP0008538	Support, spindle shaft	3
29	5BP0008536	Spacer	3
30	5BP0006634A	Bearing 6205-Z	3
31	5BP0008533	Spindle assembly	-

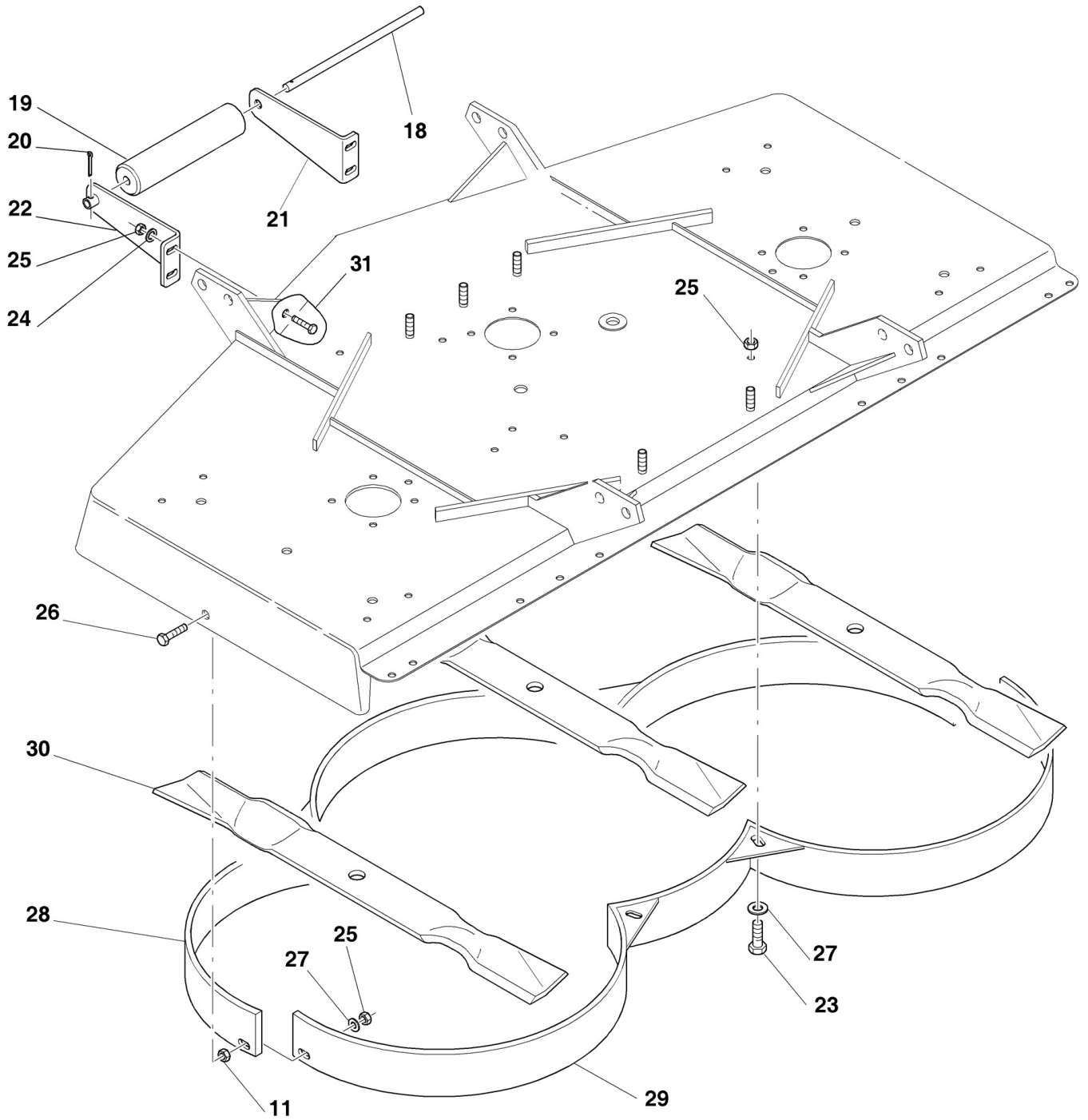

Ref.	Part #	Description	Qty.
11	5BP0003038	Nut HH M12-1.75 C6 Z TK	6
18	5BP0008929	Roller pin	1
19	5BP0067358	Front roller 3"	1
20	5BP0112087	Pin split Ø4x50 Z	1
21	5BP0008923	Roller support, right	1
22	5BP0208924	Roller support, left	1
23	5BP0006349	Bolt HH M10-1.50x20 C8.8 Z F	-
24	5BP0002034	Washer flat Ø10 W	4
25	5BP0030156	Nut PT M10-1.50 C6 TK Z	-
26	5BP0091281	Bolt HH M10-1.50x35 C8.8 Z F	2
27	5BP0030157	Washer fender Ø10 Z	-
28	5BP0008755	Baffling, front 4' frame; GM1048E	1
	5BP0115824	Baffling, front 5' frame; GM1060E	1
	5BP0008759	Baffling, front 6' frame; GM1072E	1
29	5BP0008756	Baffling, rear 4' frame; GM1048E	1
	5BP0115825	Baffling, rear 5' frame; GM1060E	1
	5BP0008760	Baffling, rear 6' frame; GM1072E	1
30	5BP0006795M	Blade mulching 4' frame; GM1048E	3
	5BP0006641M	Blade mulching 5' frame; GM1060E	3
	5BP0006845M	Blade mulching 6' frame; GM1072E	3
31	5BP0033176	Bolt HH M10-1.50x25 C8.8 Z F	4

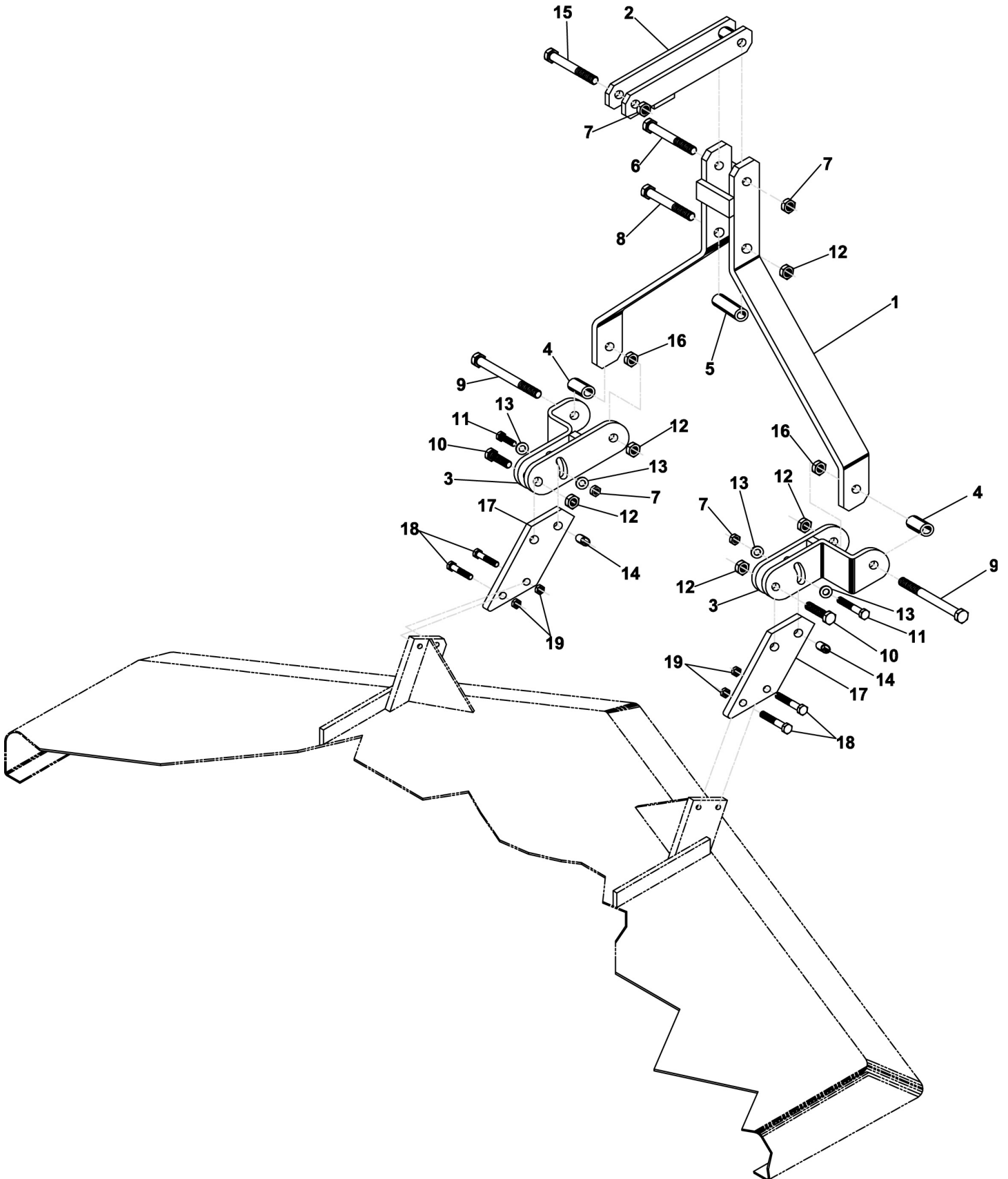



Ref.	Part #	Description	Qty.
1	5BP503753B	A-frame support	1
2	5BP503754B	Floating top link	1
3	5BP0051941	Floating yoke	2
4	5BP503755B	Spacer 1-3/8"	2
5	5BP503756B	Spacer 1-1/8"	1
6	5BP0070346	Bolt HH M16-2.00x110 C8.8 Z P	1
7	5BP0005581	Nut PT M16-2.00 C6 Z TK	4
8	5BP0051953	Bolt HH M20-2.50x110 C8.8 Z P	1
9	5BP0051954	Bolt HH M20-2.50x140 C8.8 Z P	2
10	5BP0008576	Bolt HH M20-2.50x65 C8.8 Z F	2
11	5BP0006577	Bolt HH M16-2.00x60 C8.8 Z P	2
12	5BP0005507	Nut PT M20-2.50 C6 TK Z	5
13	5BP0008568	Washer flat Ø16 W	4
14	5BP503757B	Bushing	2
15	5BP0008029	Bolt HH M16-2.00x90 C8.8 Z P	1
16	5BP0015686	Nut HH M20-2.50 C6 Z TN	2
17	5BP0051817	Linking plates <sup>20</sup>	2
18	5BP0006578	Bolt HH M16-2.00x45 C8.8 Z F <sup>21</sup>	4
19	5BP0005581	Nut PT M16-2.00 C6 Z TK <sup>22</sup>	4
	5BP006750	Quick-Hitch adapter complete (field conversion kit) <sup>23</sup>	1
	5BP971378B	Assembly manual, quick-hitch adapter	1

<sup>20</sup> The linking plates (5BP0051817) come with the mower and are not part of the quick hitch adapter kit. Mowers with serial #BC...844970 & below do not need the linking plates to attach the quick hitch adapter.

<sup>21</sup> The four (4) bolts (5BP0006578) and (4) nuts (5BP0005581) come with the mower and are not part of the quick hitch adapter kit.

<sup>22</sup> The four (4) bolts (5BP0006578) and (4) nuts (5BP0005581) come with the mower and are not part of the quick hitch adapter kit.

<sup>23</sup> When ordering the quick hitch adapter together with the GM1060E or the GM1048E mower, the original driveline of the mower will be changed to part number 5BP0500404.

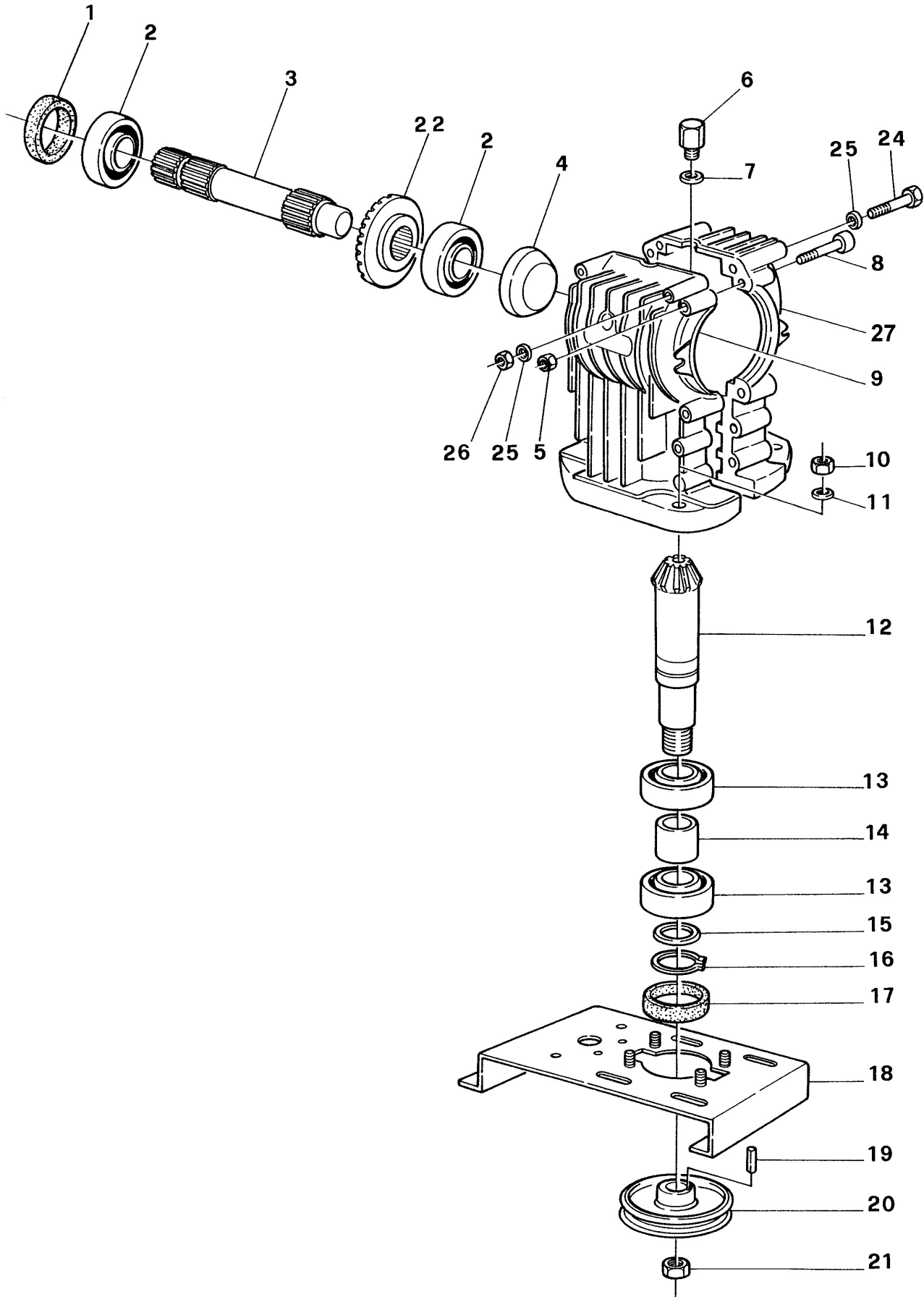

Ref.	Part #	Description	Qty.
1	5BP0010192	Oil seal 40.68.10	1
2	5BP0012149A	Bearing 6208	2
3	5BP0008892	Input shaft	1
4	5BP0008609	Cap	1
5	5BP0001806	Nut HH M08-1.25 C6 Z TK	8
6	5BP0008598	Breather cap; #BC...304739 & below	1
	5BP0010177	Breather cap; #BC...304740 & above	1
7	5BP0008601	Gasket, breather cap	1
8	5BP0010171	Bolt SC M08-1.25x50 C8.8 Z P	8
9	5BP3300101	Housing, gearbox w/center fill hole; #BC...304739 & below <sup>24</sup>	2
	5BP0051891	Housing, gearbox w/o fill hole; #BC...304740 & above	1
10	5BP0003038	Nut HH M12-1.75 C6 Z TK	4
11	5BP0001077	Washer lock Ø12 Z	4
12	5BP0050192	Pinion gear	1
13	5BP0025332A	Bearing 6207	2
14	5BP0010196	Spacer	1
15	5BP0034196	Shim Ø35x45x2.5	1
16	5BP0042122	Snap ring, outer Ø35	1
17	5BP0002295	Oil seal 35.62.10	1
18	5BP0051581	Central plate 4' frame; GM1048E	1
	5BP0051583	Central plate 5' frame; GM1060E	1
	5BP0051585	Central plate 6' frame; GM1072E	1
19	5BP0006688	Key 8x7x35	1
20	5BP0008623	Pulley SPB 250x1	1
21	5BP0006698	Nut SP M25-1.50 Z	1
22	5BP0008893	Ring gear	1
24	5BP0015263	Bolt HH M10-1.50x120 C8.8 Z P	2
25	5BP0002034	Washer flat Ø10 W	4
26	5BP0030156	Nut PT M10-1.50 C6 TK Z	2
27	5BP0051892	Housing, gearbox w/fill hole; #BC...304740 & above	1
	5BP0500620	Gearbox complete 540 rpm; #BC...304739 & below <sup>25</sup>	1
	5BP0500647	Gearbox complete 540 rpm; #BC...304740 & above	1

<sup>24</sup> A limited quantity of these gearbox housings is available, after which both left and right housings (# 5BP3300101) need to be replaced with part # 5BP0051891 and part # 5BP0051892.

<sup>25</sup> Gearbox no longer available should be replaced with gearbox part # 5BP0500647.

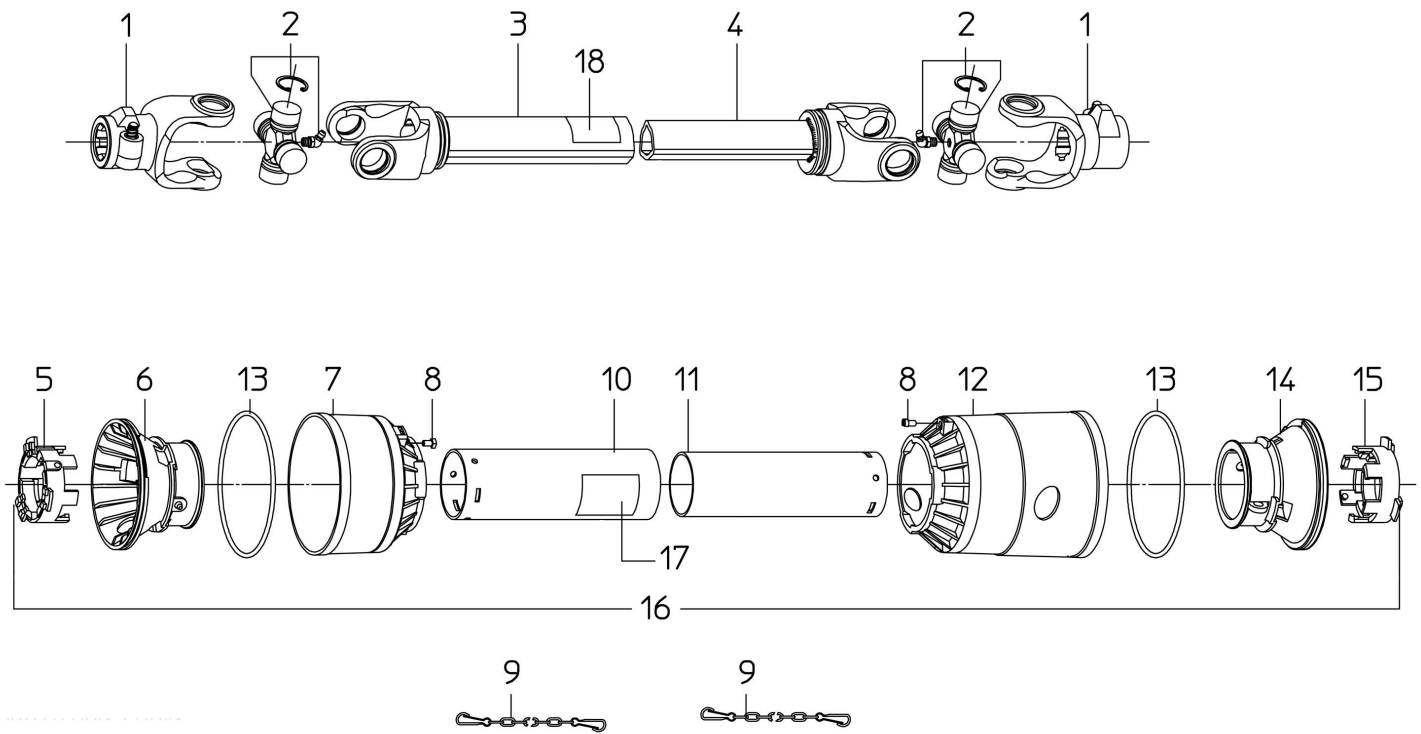

## GM1048E, GM1060E, GM1072E; #XF...276188 &amp; BELOW

Ref.	Part #	Description	Qty.
1	5BP1022010C	PTO yoke	2
2	5BP1002020C	Cross w/bearing	2
3	5BP1942045NC	Outer tube w/yoke; GM1048E	1
	5BP1942055NC	Outer tube w/yoke; GM1060E	1
	5BP1942070NC	Outer tube w/yoke; GM1072E	1
4	5BP1952047NC	Inner tube w/yoke; GM1048E	1
	5BP1952057NC	Inner tube w/yoke; GM1060E	1
	5BP1952072NC	Inner tube w/yoke; GM1072E	1
5	5BP1782210C	Locking ring, outer tube; #XF...276188 & below	1
6	5BP1784201C	Rigid cone, outer tube; #XF...276188 & below	1
7	5BP1784203C	Standard cone (tractor end); #XF...276188 & below	1
8	5BP1784212C	Pin; #XF...276188 & below	2
9	5BP1006065C	Chain, anti-rotation	2
10	5BP1773043C	Shield, outer tube; GM1048E	1
	5BP1773053C	Shield, outer tube; GM1060E	1
	5BP1773068C	Shield, outer tube; GM1072E	1
11	5BP1872043C	Shield, inner tube; GM1048E	1
	5BP1872053C	Shield, inner tube; GM1060E	1
	5BP1872068C	Shield, inner tube; GM1072E	1
12	5BP1784205C	Long cone (implement end); #XF...276188 & below	1
13	5BP1213233C	Stiffening ring; #XF...276188 & below	2
14	5BP1784202C	Rigid cone, inner tube; #XF...276188 & below	1
15	5BP1782211C	Locking ring, inner tube; #XF...276188 & below	1
16	5BP90SL2043C	Shield, complete; GM1048E <sup>26</sup>	1
	5BP90SL2053C	Shield, complete; GM1060E <sup>27</sup>	1
	5BP90SL2068C	Shield, complete; GM1072E <sup>28</sup>	1
17	5BP950463B	Decal "DANGER - Rotating driveline, keep away" outer shield	1
18	5BP950464B	Decal "DANGER - Guard missing, do not operate" outer tube	1
	5BP0500402	Driveline, complete; GM1048E	-
	5BP0500403	Driveline, complete; GM1060E	-
	5BP0500404	Driveline, complete; GM1072E	-

<sup>26</sup> Complete shield is interchangeable with part # 5BP96SL2043C.

<sup>27</sup> Complete shield is interchangeable with part # 5BP96SL2053C.

<sup>28</sup> Complete shield is interchangeable with part # 5BP96SL2068C.

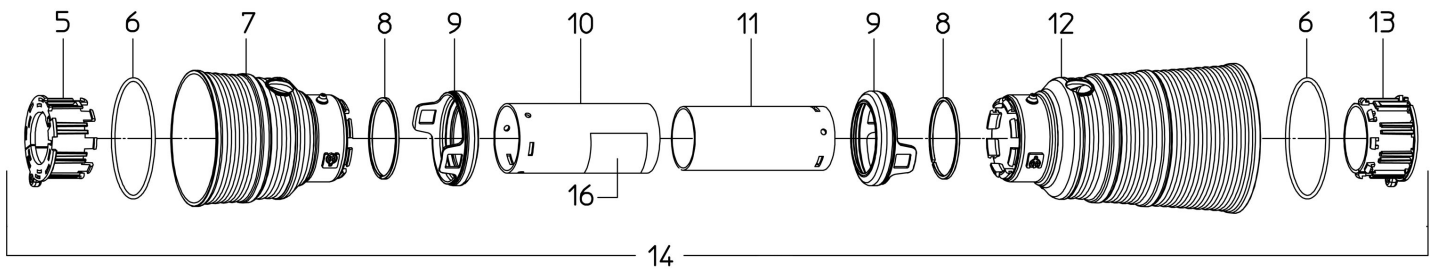
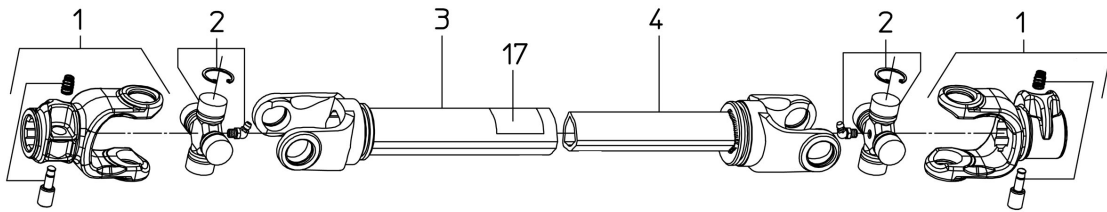

## GM1048E, GM1060E, GM1072E; FROM #XF...276189 TO #XF...286013

Ref.	Part #	Description	Qty.
1	5BP1022010C	PTO yoke <sup>29</sup>	2
2	5BP1002020C	Cross w/bearing <sup>30</sup>	2
3	5BP1942045NC	Outer tube w/yoke; GM1048E <sup>31</sup>	1
	5BP1942055NC	Outer tube w/yoke; GM1060E <sup>32</sup>	1
	5BP1942070NC	Outer tube w/yoke; GM1072E <sup>33</sup>	1
4	5BP1952047NC	Inner tube w/yoke; GM1048E <sup>34</sup>	1
	5BP1952057NC	Inner tube w/yoke; GM1060E <sup>35</sup>	1
	5BP1952072NC	Inner tube w/yoke; GM1072E <sup>36</sup>	1
5	5BP1782710C	Locking ring, outer tube; from #XF...276189 to XF...286013	1
6	5BP1211733C	Stiffening ring; from #XF...276189 to XF...286013	2
7	5BP1781703C	Standard cone (tractor end); from #XF...276189 to XF...286013	1
8	5BP1211735C	Safety ring; from #XF...276189 to XF...286013	2
9	5BP1881709C	Safety sleeve; from #XF...276189 to XF...286013	2
10	5BP1773043C	Shield, outer tube; GM1048E #XF...286013 & below	1
	5BP1773053C	Shield, outer tube; GM1060E #XF...286013 & below	1
	5BP1773068C	Shield, outer tube; GM1072E #XF...286013 & below	1
11	5BP1872043C	Shield, inner tube; GM1048E #XF...286013 & below	1
	5BP1872053C	Shield, inner tube; GM1060E #XF...286013 & below	1
	5BP1872068C	Shield, inner tube; GM1072E #XF...286013 & below	1
12	5BP1781704C	Long cone (implement end); from #XF...276189 to XF...286013	1
13	5BP1782711C	Locking ring, inner tube; from #XF...276189 to XF...286013	1
14	5BP96SL2043C	Shield, complete; GM1048E <sup>37</sup>	1
	5BP96SL2053C	Shield, complete; GM1060E <sup>38</sup>	1
	5BP96SL2068C	Shield, complete; GM1072E <sup>39</sup>	1
15	5BP1006065C	Chain, anti-rotation <sup>40</sup>	2
16	5BP950463B	Decal "DANGER - Rotating driveline, keep away" outer shield	1
17	5BP950464B	Decal "DANGER - Guard missing, do not operate" outer tube	1
	5BP0500402	Driveline, complete; GM1048E <sup>41</sup>	-
	5BP0500403	Driveline, complete; GM1060E <sup>42</sup>	-
	5BP0500404	Driveline, complete; GM1072E <sup>43</sup>	-

<sup>29</sup> Yoke interchangeable with part # 5BP1002138A.

<sup>30</sup> Cross w/bearing interchangeable with part # 5BP1802010A.

<sup>31</sup> Outer tube w/yoke interchangeable with part # 5BPZ020512A.

<sup>32</sup> Outer tube w/yoke interchangeable with part # 5BPZ020612A.

<sup>33</sup> Outer tube w/yoke interchangeable with part # 5BPZ020762A.

<sup>34</sup> Inner tube w/yoke interchangeable with part # 5BPZ120512A.

<sup>35</sup> Inner tube w/yoke interchangeable with part # 5BPZ120612A.

<sup>36</sup> Inner tube w/yoke interchangeable with part # 5BPZ120762A.

<sup>37</sup> Complete shield interchangeable with part # 5BPP62064SLA.

<sup>38</sup> Complete shield interchangeable with part # 5BPP62074SLA.

<sup>39</sup> Complete shield interchangeable with part # 5BPP62089SLA.

<sup>40</sup> Chain interchangeable with part # 5BP5990030A.

<sup>41</sup> Complete driveline interchangeable with part # 5BP0500100.

<sup>42</sup> Complete driveline interchangeable with part # 5BP0500101.

<sup>43</sup> Complete driveline interchangeable with part # 5BP0500102.

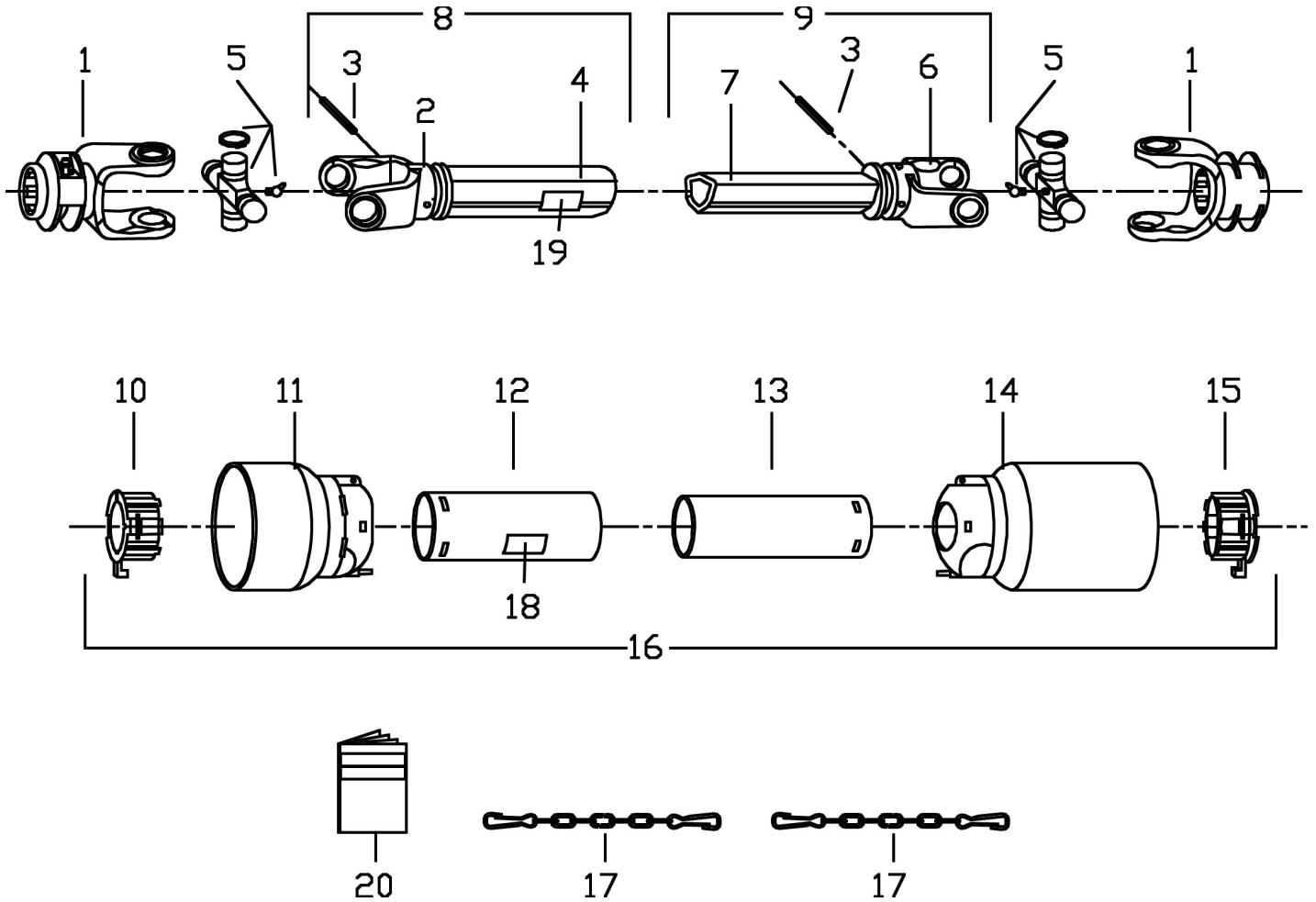



## GM1048E, GM1060E, GM1072E; #XF...286014 &amp; ABOVE

Ref.	Part #	Description	Qty.
1	5BP1002138A	PTO yoke	2
2	5BP1902010A	Yoke, outer tube; #XF...286014 & above	1
3	5BP0008679	Roll pin Ø8x55; #XF...286014 & above	2
4	5BP3020512A	Outer tube; GM1048E #XF...286014 & above	1
	5BP3020612A	Outer tube; GM1060E #XF...286014 & above	1
	5BP3020762A	Outer tube; GM1072E #XF...286014 & above	1
5	5BP1802010A	Cross w/bearing	2
6	5BP1902012A	Yoke, inner tube; #XF...286014 & above	1
7	5BP3120512A	Inner tube; GM1048E #XF...286014 & above	1
	5BP3120612A	Inner tube; GM1060E #XF...286014 & above	1
	5BP3120762A	Inner tube; GM1072E #XF...286014 & above	1
8	5BPZ020512A	Outer tube w/yoke, complete; GM1048E	1
	5BPZ020612A	Outer tube w/yoke, complete; GM1060E	1
	5BPZ020762A	Outer tube w/yoke, complete; GM1072E	1
9	5BPZ120512A	Inner tube w/yoke, complete; GM1048E	1
	5BPZ120612A	Inner tube w/yoke, complete; GM1060E	1
	5BPZ120762A	Inner tube w/yoke, complete; GM1072E	1
10	5BP6002010A	Locking ring, outer tube; #XF...286014 & above	1
11	5BP6014010A	Standard cone; tractor end; #XF...286014 & above	1
12	5BP5820452EA	Shield, outer tube; GM1048E #XF...286014 & above	1
	5BP5820552EA	Shield, outer tube; GM1060E #XF...286014 & above	1
	5BP5820702EA	Shield, outer tube; GM1072E #XF...286014 & above	1
13	5BP5820452IA	Shield, inner tube; GM1048E #XF...286014 & above	1
	5BP5820552IA	Shield, inner tube; GM1060E #XF...286014 & above	1
	5BP5820702IA	Shield, inner tube; GM1072E #XF...286014 & above	1
14	5BP6014025A	Long cone; implement end; #XF...286014 & above	1
15	5BP6002012A	Locking ring, inner tube; #XF...286014 & above	1
16	5BPP62064SLA	Shield, complete; GM1048E	1
	5BPP62074SLA	Shield, complete; GM1060E	1
	5BPP62089SLA	Shield, complete; GM1072E	1
17	5BP5990030A	Chain, anti-rotation	2
18	5BP950463B	Decal "DANGER - Rotating driveline, keep away", outer shield	1
19	5BP950464B	Decal "DANGER - Guard missing, do not operate", outer tube	1
20	5BP8909090A	Operator's manual, driveline	1
	5BP0500100	Driveline, complete; GM1048E	-
	5BP0500101	Driveline, complete; GM1060E	-
	5BP0500102	Driveline, complete; GM1072E	-

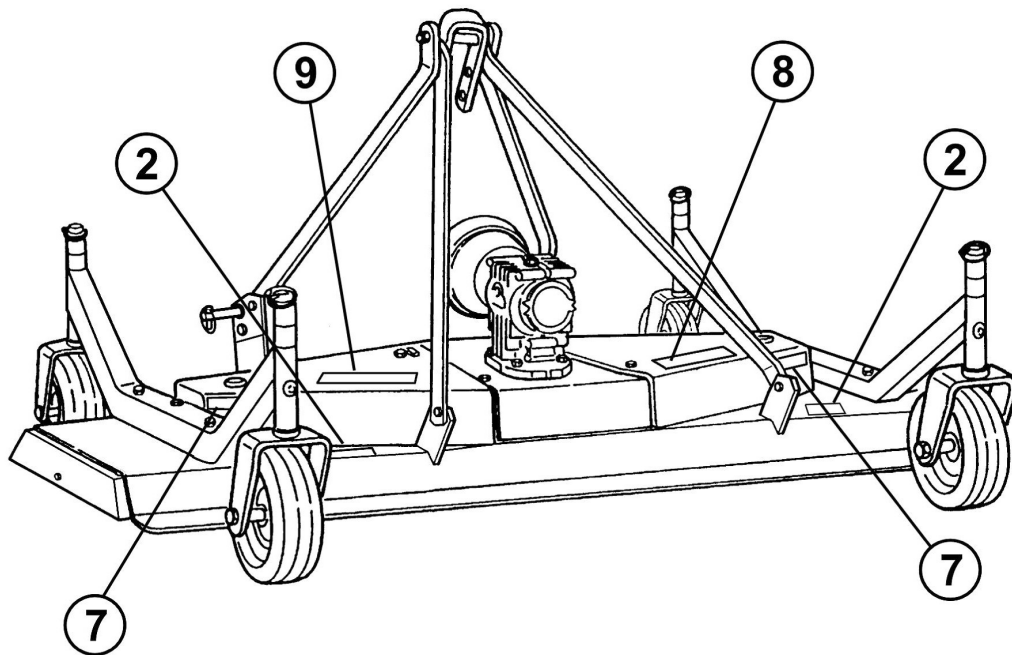
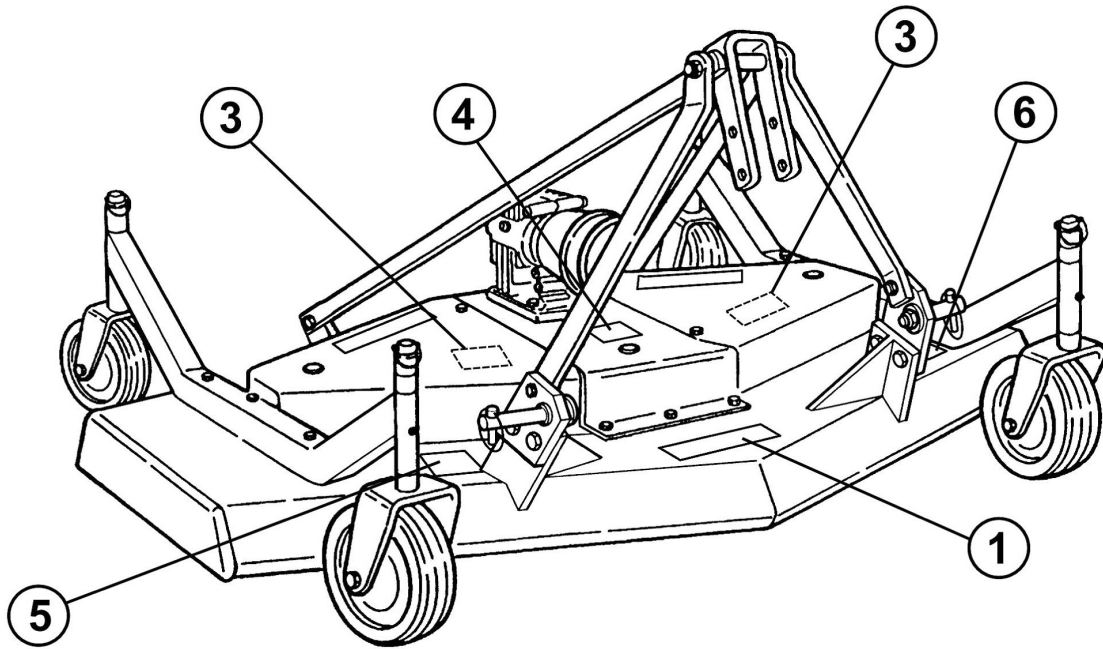

Ref.	Part #	Description	Qty.
1	5BP950109B	Decal "DANGER - Avoid injury from PTO"	1
2	5BP950818B	Decal "DANGER - Rotating blades; Thrown objects"	2
3	5BP950213B	Decal "DANGER - Replace shields", placed under belt shields	2
4	5BP950406B	Decal "WARNING - Falling off"	1
5	5BP950407B	Decal "WARNING - Crushing and pinching hazard"	1
6	5BP950111B	Decal "CAUTION - To avoid serious injury"	1
7	5BP950366B	Decal, red reflective	2
8	5BP950362B	Decal "GM1048E"	1
	5BP950363B	Decal "GM1060E"	1
	5BP950364B	Decal "GM1072E"	1
9	5BP950346B	Decal "Frontier"	1
	5BP950367B	Decal, safety set, mower in English	-
	5BP950959B	Decal, safety set, mower & operator's manual in French	-
	5BP960379B	Operator's & Parts Manual GM1048E, GM1060E, GM1072E	1

**Note:** Serial #'s with the XF prefix are subsequent to serial numbers with the BC prefix. For example: A reference to "serial # BC... 739197 & above" will also include all serial numbers with an XF prefix.

## Use only original spare parts

*All rights reserved. It is unlawful to copy, reprint or use any of the information or details in this manual without the expressed written permission of the Company. Technical information provided in this manual is approximate, the Company reserves the right to modify or improve the models shown for technical or commercial purposes. Pictures in this manual do not necessarily show the machine as delivered.*



Manual 5BP960379B  
Date 11/11/2010

## Free Manuals Download Website

<http://myh66.com>

<http://usermanuals.us>

<http://www.somanuals.com>

<http://www.4manuals.cc>

<http://www.manual-lib.com>

<http://www.404manual.com>

<http://www.luxmanual.com>

<http://aubethermostatmanual.com>

Golf course search by state

<http://golfingnear.com>

Email search by domain

<http://emailbydomain.com>

Auto manuals search

<http://auto.somanuals.com>

TV manuals search

<http://tv.somanuals.com>