

OPERATOR'S MANUAL

GROOMING MOWERS

GM2060

GM2072

GM2084

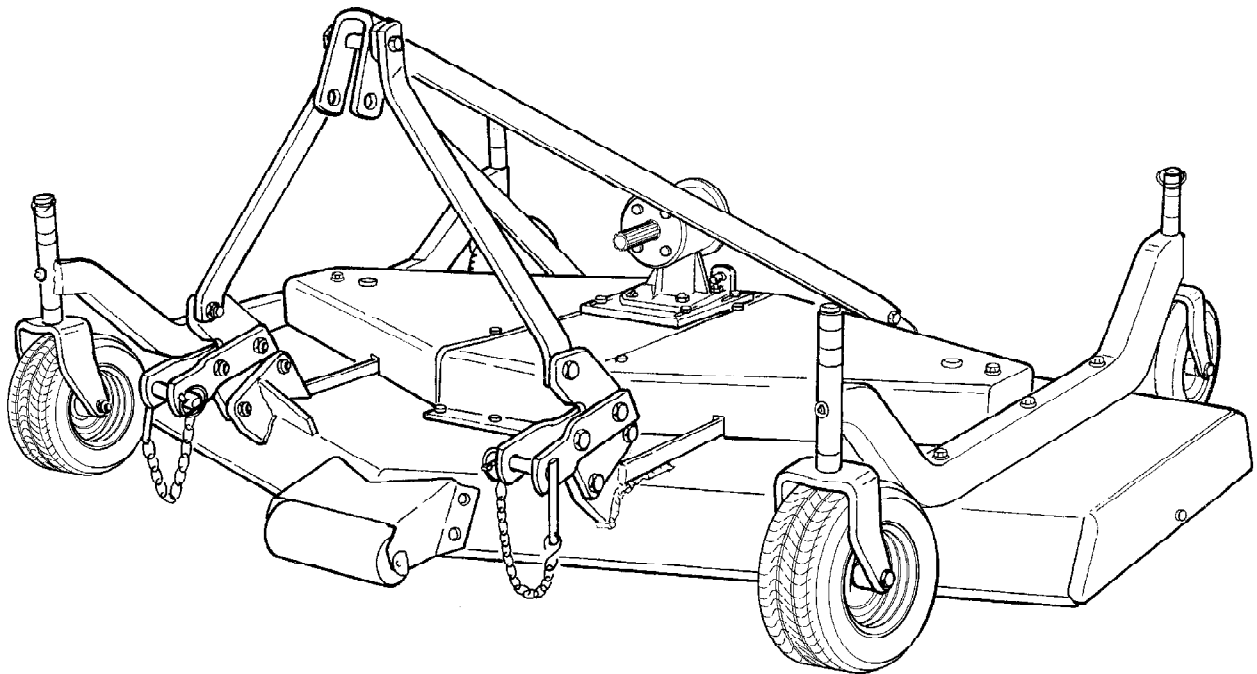

Manual 5BP960384B
Date 06/01/2009

SAFETY

Take note! This safety alert symbol found throughout this manual is used to call your attention to instructions involving your personal safety and the safety of others. Failure to follow these instructions can result in injury or death.



*This symbol means:
ATTENTION!
BECOME ALERT!
YOUR SAFETY IS INVOLVED!*

Signal Words

Note the use of the signal words DANGER, WARNING and CAUTION with the safety messages. The appropriate signal words for each have been selected using the following guidelines:



DANGER: Indicates an imminently hazardous situation that, if not avoided, will result in death or serious injury.



WARNING: Indicates a potentially hazardous situation that, if not avoided, could result in death or serious injury, and includes hazards that are exposed when guards are removed. It may also be used to alert against unsafe practices.



CAUTION: Indicates a potentially hazardous situation that, if not avoided, may result in minor or moderate injury.

INDEX

1 - GENERAL INFORMATION	4
1.01 - General	4
1.02 - Model and Serial Number ID	4
1.03 - Assembly Instructions	5
2 - SAFETY PRECAUTIONS	7
2.01 - Preparation	7
2.02 - Starting and Stopping	8
2.03 - Messages and Signs	8
3 - OPERATION	11
3.01 - Operational Safety	11
3.02 - Set Up	13
3.03 - Cutting Height Adjustment	13
3.04 - Pre-Operational Check	14
3.05 - Attaching to the Tractor	15
3.06 - Start Up	16
3.07 - Working Speed	17
3.08 - Operating Techniques	17
3.09 - Uneven Terrain	19
3.10 - Removing Mower from the Tractor	19
3.11 - Transport	19
3.12 - Quick Hitch Adapter Assembly and Operation	20
4 - MAINTENANCE	23
4.01 - Maintenance Safety	23
4.02 - Service	24
4.03 - Blade Maintenance	25
4.04 - Belt Tension	27
4.05 - Belt Replacement	28
4.06 - Driveline	29
5 - REPAIR PROCEDURES	32
5.01 - Gearbox	32
5.02 - Blade Spindle	32
5.03 - Suggested Spare Parts	33
5.04 - Storage	33
6 - TROUBLESHOOTING	34
7 - PRE-DELIVERY CHECKLIST	35
PARTS MANUAL	37

1 - GENERAL INFORMATION

Thank you and congratulations for having chosen our implement. Your new grooming mower is a technologically advanced machine constructed of high quality, sturdy components that will fulfill your working expectations. Read this manual carefully. It will instruct you on how to operate and service your mower safely and correctly. Failure to do so could result in personal injury and/or in equipment damage.

1.01 - General



CAUTION: Unless otherwise specified, all hardware is metric. Use only metric tools on metric hardware. Other tools that do not fit properly can slip and cause injury.



CAUTION: Right hand and left hand sides of the implement are determined by facing in the direction the implement will travel when going forward (see fig. 4).

1.02 - Model and Serial Number ID

Attached to the frame is an ID plate showing the model and the serial number. Record your implement model and serial number in the space provided below. Your dealer needs this information to give you prompt, efficient service when you order parts.



Warranty coverage is provided by John Deere according to the terms of the Agricultural/Commercial & Consumer Equipment Warranty Statement. Carefully read the warranty statement on the back of your original purchase order for details on coverage and limitations of this warranty.

Your Authorized Company Dealer has genuine parts in stock. Only these approved replacement parts should be used.

1.03 - Assembly Instructions



CAUTION: Stand clear of bands when cutting as they could be under sufficient tension to cause them to fly loose. Take care in removing bands and wire. They often have extremely sharp edges and cut very easily.

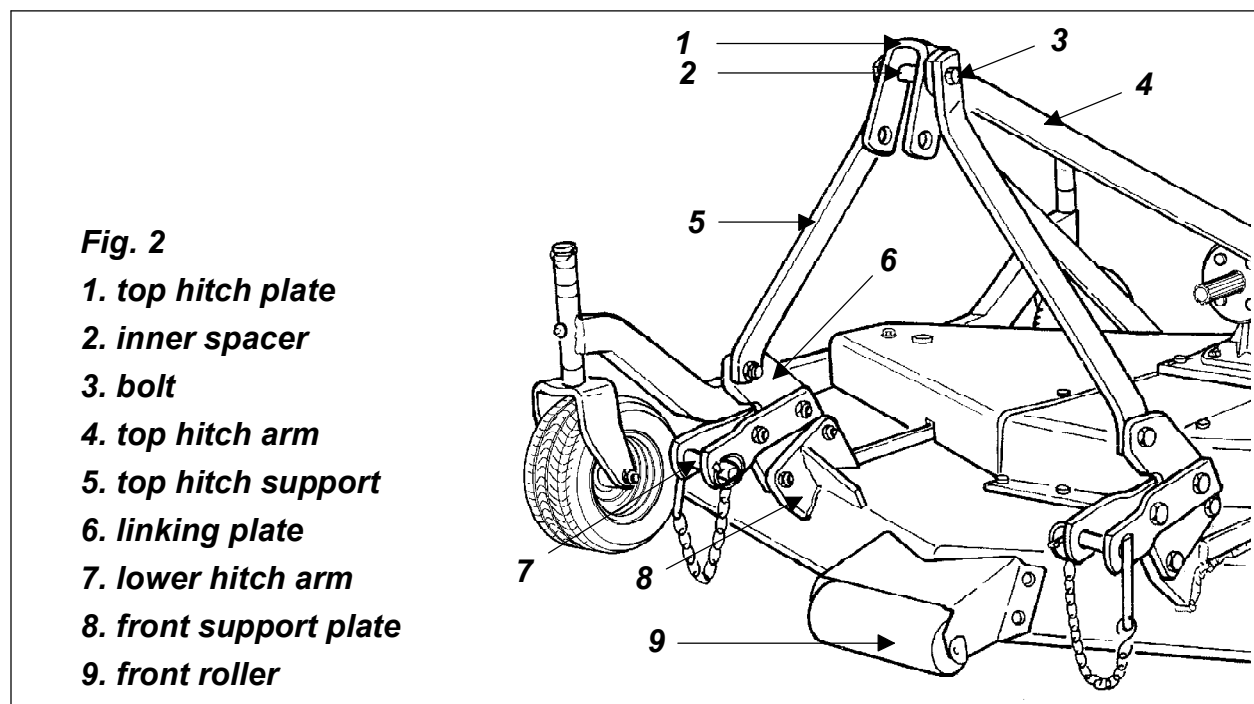

1. Unbolt the wheel arms from the side of the crate.
2. Remove the hardware bag secured to the top hitch arms.
3. **IMPORTANT:** Remove the belt shields to inspect around the belt area and under the gearbox central plate to be sure the area is clear of packing material such as blocks of wood, paper, etc.
4. Bolt the wheel arm assemblies to the mower deck with the flat washers $\text{\O}10$ and locknuts M10. There is no difference between left/right or front/rear. Be sure both assemblies are securely mounted.
5. Assemble each wheel to the yokes with one bolt M14x150, one nut M14, one inner bushing and two side spacers. Tighten down snugly. The wheel should turn freely but have no side to side movement.
6. Replace the belt shields.

7. Bolt up the top hitch arms (see #4, fig. 2 & 3) to the **outside** of the rear support plates (see #10, fig. 3) on the rear of the mower.
8. Bolt up the top hitch supports to the **inside** of the linking plates (see #6, fig. 2). **Use the top holes** (see fig. 2).
9. Bolt up the top hitch plate (see #1, fig. 2 & 3) with the bolt M16x140 (see #3, fig. 2). It should be bolted as follows: bolt, top hitch support, top hitch arm, top hitch plate, spacer, top hitch arm, top hitch support, locknut M16. **Tighten the locknut down securely, the top hitch plate should be able to swivel 360°** (see fig. 2).
10. Install the lower hitch arms (see #7, fig. 2) in the lower hole of the linking plates (see #6, fig. 2). If assembled properly, the hitch plates will rest on the "thumb" of the linking plate when down. Tighten the bolts holding the lower hitch arms. Be sure they are able to swivel.
11. Grease wheels, wheel arms, and spindles. Check the gearbox for oil. It should be approximately ½ filled.
12. Install driveline and ensure it has at least 2" from bottoming out in its shortest working position and has the minimum 6" overlap in its longest working position. Refer to **Section 4.06¹** of this manual, if it is determined that the driveline is too long and needs to be shortened. Contact your local dealer if it is determined that the driveline is too short for your tractor .

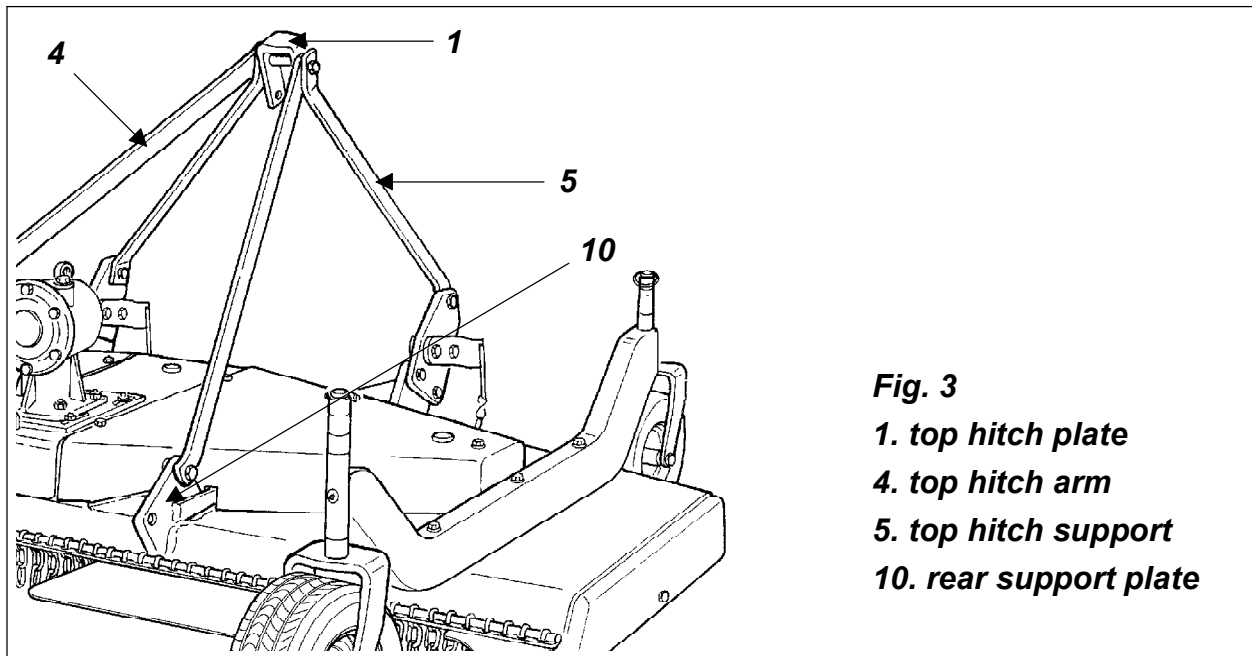

Fig. 3

- 1. top hitch plate**
- 4. top hitch arm**
- 5. top hitch support**
- 10. rear support plate**

¹ See Section 4.06 - Driveline, for instructions on how to determine correct driveline length and procedures for shortening the driveline.

2 - SAFETY PRECAUTIONS

Safety is the primary concern in the design and manufacture of our products. Unfortunately our efforts to provide safe equipment can be wiped out by a single careless act of an operator.

In addition to the design and configuration of equipment, hazard control and accident prevention are dependent upon the awareness, concern, prudence and proper training of personnel involved in the operation, transport, maintenance and storage of equipment. It is the operator's responsibility to read and understand all safety and operating instructions in the manual and to follow these.

Allow only properly trained personnel to operate the mower. Working with unfamiliar equipment can lead to careless injuries. Read this manual, and the manual for your tractor, before assembly or operation, to acquaint yourself with the machines. It is the mower owner's responsibility, if this machine is used by any person other than yourself, is loaned or rented, to make certain that the operator, prior to operating, reads and understands the operator's manuals and is instructed in safe and proper use.

2.01 - Preparation



1. Before operating equipment read and understand the operator's manual and the safety signs (**see fig. 4**).
2. Thoroughly inspect the implement before initial operation to assure that all packaging materials, i.e. wires, bands, and tape have been removed.
3. Personal protection equipment including hard hat, safety glasses, safety shoes, and gloves are recommended during assembly, installation, operation, adjustment, maintaining and/or repairing the implement.
4. Operate the mower only with a tractor equipped with an approved Roll-Over-Protective-System (ROPS). Always wear your seat belt. Serious injury or even death could result from falling off the tractor.
5. Clear area to be cut of stones, branches or other debris that might be thrown, causing injury or damage.
6. Operate only in daylight or good artificial light.
7. Ensure mower is properly mounted, adjusted and in good operating condition.
8. Ensure that all safety shielding and safety signs are properly installed and in good condition.

2.02 - Starting and Stopping



1. Be sure that no one is near the machine prior to engaging or while the machine is working.
2. Be sure the tractor is in "Neutral" before starting engine.
3. Mower operating power is supplied from tractor PTO. Refer to your tractor manual for PTO engagement and disengagement instructions. Always operate PTO at 540 rpm. Know how to stop the tractor and mower quickly in case of an emergency.
4. When engaging PTO, the engine rpm should always be low. Once engaged and ready to start cutting, raise PTO speed to 540 rpm and maintain throughout cutting operation.
5. Check the tractor master shield over the PTO stub shaft. Make sure it is in good condition and fastened securely to the tractor. Purchase a new shield if old shield is damaged or missing.
6. After striking an obstacle, disengage the PTO, shut the tractor down and thoroughly inspect for damage before restarting.
7. Never engage the PTO until the mower is in the down position and resting on the ground. Never raise the mower until all blades have come to a complete stop.
8. To park the vehicle safely, stop vehicle on a level surface (not on a slope), disengage PTO, engage the parking brake, stop the engine, remove the key, and wait for engine and all moving parts to stop before leaving the operator's seat.
9. Stay clear of rotating drivelines. Entanglement in rotating driveline can cause serious injury or death. Wear close fitting clothing. Stop the engine and be sure PTO driveline is stopped before getting near it.

2.03 - Messages and Signs



1. Read and adhere to all safety and operating decals on this machine **(see fig. 4)**.
2. Before dismounting tractor: allow moving parts to stop, stop engine, set brake and remove the key of unattended equipment.
3. Keep away from rotating blades and driveline.
4. Keep guards and shields in place and in good condition.
5. Do not mow with bystanders in area.
6. Allow no riders on tractor or mower.
7. Allow moving parts to stop before repair.
8. Securely support mower before working underneath.

Additional warning and operating decals are available at no extra charge. Please specify model and serial number when ordering.

Fig. 4 - Safety decals ; replace immediately if damaged.

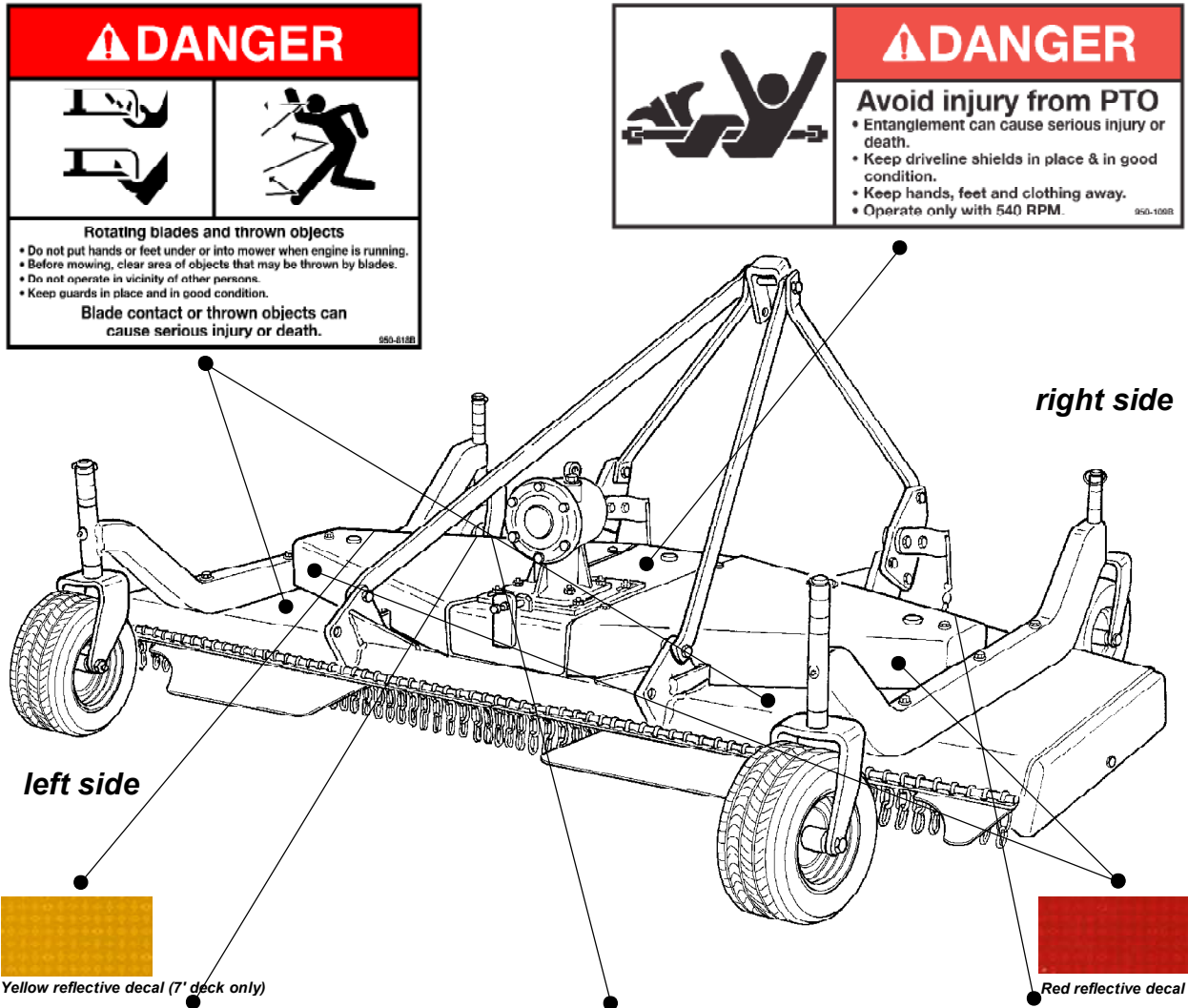

⚠ DANGER

Rotating blades and thrown objects

- Do not put hands or feet under or into mower when engine is running.
- Before mowing, clear area of objects that may be thrown by blades.
- Do not operate in vicinity of other persons.
- Keep guards in place and in good condition.

Blade contact or thrown objects can cause serious injury or death.

950-8188

⚠ DANGER

Avoid injury from PTO

- Entanglement can cause serious injury or death.
- Keep driveline shields in place & in good condition.
- Keep hands, feet and clothing away.
- Operate only with 540 RPM.

950-1028

Yellow reflective decal (7' deck only)

Red reflective decal

⚠ CAUTION

To avoid serious injury:

- Read Operator's Manual before operating, servicing or repairing equipment. Follow all safety rules and instructions. (Manuals are available from your selling dealer).
- Know location and function of controls.
- Keep all shields in place and in good condition.
- Stay clear of power driven parts.
- Never allow riders.
- Never allow children or untrained persons to operate equipment.
- Keep bystanders at a safe distance away from mower during operation.
- Before mowing, clear area of objects that may be thrown by blades.
- Use extra caution on uneven terrain. Decrease speed when turning.
- Tractor must be equipped with a Roll-Over-Protection-System (ROPS) and seatbelt.
- Keep foldable ROPS systems in the "locked up" position at all times.
- Keep seatbelt securely fastened.

Before dismounting or servicing

- Shut off engine and remove key.
- Lock parking brake.
- Wait for all movement to stop
- Lower or block up mower.

950-1118

⚠ WARNING

Falling off can result in being run over.

- Tractor must be equipped with ROPS (or ROPS CAB) and seat belt. Keep foldable ROPS system in "locked up" position at all times.
- Buckle up! Keep seat belt securely fastened.
- Allow no riders.

Raised equipment can drop and crush.

- Before working underneath, follow all instructions and safety rules in operator's manual and securely block all corners of equipment with jack stands.
- Securely blocking prevents equipment dropping from hydraulic leakdown, hydraulic system failures or mechanical component failures.

Falling off or failing to block securely can result in serious injury or death.

950-4086

⚠ WARNING

Crushing and Pinching Hazard

- Be extremely careful handling various parts of the hitching mechanism. They are heavy and hands, fingers, feet, and other body parts could be crushed or pinched between tractor and implement.
- Operate tractor controls from tractor seat only.
- Do not stand between tractor and implement when tractor is in gear.
- Make sure parking brake is engaged before going between tractor and implement.
- Stand clear of machine while in operation or when it is being raised or lowered.

Failure to follow these instructions could result in serious injury or death.

950-4078

Safety decals; replace immediately if damaged.

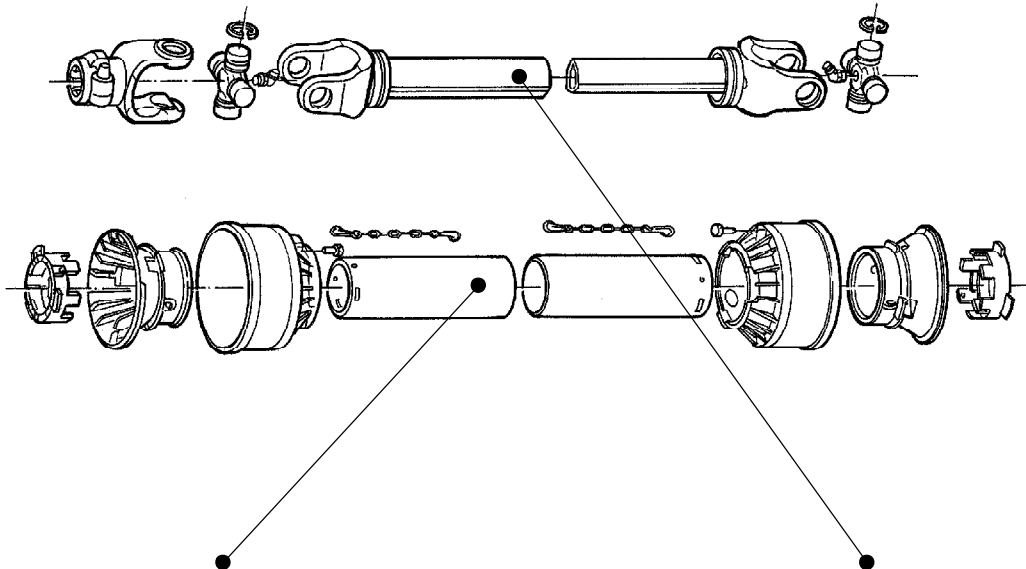

3 - OPERATION

You have purchased a three spindle mower designed especially for the mowing of grassy areas where a highly professional cut is required without wasting time.

This mower is perfect for the maintenance of parks, private lawns, industrial parks, airports, hospital grounds, schools, highways, golf courses, sport complexes, etc. The GM2 series, for tractors up to 50 HP, come in working widths of 5', 6' and 7'. The mower can be either tractor front or rear mounted. On your mower, the tractor PTO transmits its power through a driveline to a speed multiplier gearbox. A pulley is attached to the pinion gear shaft of the gearbox which, via high resistance belts, transmits power to pulleys coupled to the three individual spindle shafts. Blades are secured to these shafts which turn at a high blade tip speed to cut the grass.

Our GM2 grooming mower comes equipped with 4 swivel wheels. Aside from regulating the cutting height, the wheels are set in such a way as to allow the mower to follow the contour of the terrain and give a precise, level cut even in undulating conditions.

3.01 - Operational Safety



CAUTION: Our mowers are designed considering safety as the most important aspect and are the safest available in today's market. Unfortunately, human carelessness can override the safety features built into our machines. Injury prevention and work safety, aside from the features on our mowers, are very much due to the responsible use of the equipment. It must always be operated prudently following with great care, the safety instructions laid out in this manual.



1. The use of this equipment is subject to certain hazards which cannot be prevented by mechanical means or product design. All operators of this equipment must read and understand this entire manual, paying particular attention to safety and operating instructions, prior to using.
2. Do not operate the tractor and mower when you are tired, sick or when using medication.
3. Keep all helpers and bystanders at least several feet from a rotary mower. Only properly trained people should operate this machine.
4. When this machine is operated in populated areas where thrown objects could injure persons or property, standard equipment safety chain shielding (which is designed to reduce the possibility of thrown objects) must be installed.
5. The majority of accidents involve entanglements on the driveline, injury of bystanders by objects thrown by the rotating blades, and operators being knocked off the tractor by low hanging limbs and then being run over by the mower.

Accidents are most likely to occur with machines that are loaned or rented to someone who has not read the operator's manual and is not familiar with a rotary mower.

6. Always stop the tractor, set brake, shut off the tractor engine, remove the ignition key, lower implement to the ground and allow mower blades to come to a complete stop before dismounting tractor. Never leave equipment unattended with the tractor running.
7. Never place hands or feet under mower with tractor engine running or before you are sure all motion has stopped. Stay clear of all moving parts.
8. Do not allow riders on the mower or tractor at any time. There is no safe place for riders.
9. Do not operate unless all personnel, livestock and pets are several feet away to prevent injury by thrown objects.
10. Before backing up, disengage the mower and look behind carefully.
11. Install and secure all guards and shields before starting or operating.
12. Keep hands, feet, hair and clothing away from moving parts.
13. This rotary mower is designed for use only on tractors with 540 rpm power take off.
14. Never operate tractor and mower under trees with low hanging limbs. Operators can be knocked off the tractor and then run over by the rotating blades.
15. The rotating parts of this machine have been designed and tested for rugged use. However, they could fail upon impact with heavy, solid objects such as steel guard rails and concrete abutments. Such impact could cause the broken objects to be thrown outward at very high velocities. To reduce the possibility of property damage, serious injury, or even death, never allow the cutting blades to contact such obstacles.
16. Frequently check mower blades. They should be sharp, free of nicks and cracks and securely fastened.
17. Stop mower immediately upon striking an obstruction. Turn engine off, remove key, inspect and repair any damage before resuming operation.
18. Stay alert for holes, rocks and roots in the terrain and other hidden hazards. Keep away from drop-offs.
19. Use extreme care and maintain minimum ground speed when transporting on hillside, over rough ground and when operating close to ditches or fences. Be careful when turning sharp corners.
20. Reduce speed on slopes and sharp turns to minimize tipping or loss of control. Be careful when changing directions on slopes. Do not start or stop suddenly on slopes. Avoid operation on steep slopes.
21. When using a unit, a minimum 20% of tractor and equipment weight must be on tractor front wheels. Without this weight, tractor could tip over, causing personal injury or death. The weight may be attained with a front end loader, front wheel weights, ballast in tires or front tractor weights. When attaining a minimum 20% of tractor and equipment weight on the front wheels, you must not exceed the ROPS weight certification. Weigh the tractor and equipment. Do not guess or estimate!
22. Inspect the entire machine periodically². Look for loose fasteners, worn or broken parts, and leaky or loose fittings.

² See Chapter 4 - Maintenance.

23. Use only the driveline supplied with the mower. Do not use it if it is missing any shield or safety protection.
24. Pass diagonally through sharp dips and avoid sharp drops to prevent "hanging up" tractor and mower.
25. Avoid sudden starts and stops while traveling up or downhill.
26. Always cut down slopes; never across the face. Avoid operation on steep slopes. Slow down on sharp turns and slopes to prevent tipping and or loss of control.

3.02 - Set Up

Notice to dealer: Pre-delivery setup and service including lubrication is the responsibility of the authorized dealer. It is up to him to assure that the machine is in perfect condition and ready to be used. It is his responsibility to ensure that the customer is aware of all safety aspects and operational procedures for the mower. He must also fill out the Pre-Delivery Checklist³ prior to delivering the mower.



CAUTION: Stand clear of bands when cutting as they could be under sufficient tension to cause them to fly loose. Take care in removing bands and wire, they often have extremely sharp edges and cut very easily.

As mentioned above, all our grooming mowers may be either tractor front or rear mounted. Changing our mowers from front mount to rear, or vice versa, can be easily done at our authorized dealerships. This is accomplished by simply turning the three point hitch and the gearbox 180 degrees.

3.03 - Cutting Height Adjustment



WARNING: Keep hands and feet away from moving blades. Be sure tractor engine is off, parking brake is locked, and key is removed before making any adjustments. Never rely on the tractor lift system. Install blocks or stands under the mower deck to prevent it from falling.

The cutting height is the distance from the blades to the ground. The cutting height is adjusted by **moving the spacers on the wheel yokes**. Placing spacers between the wheel arm and the wheel yoke raises the cutting height by the size of the spacer. Removing the spacers lowers it by the same height (**see fig. 5**). Be sure all wheel arms are adjusted equally. This is the only way to ensure a completely uniform cut.

³ See Chapter 7 - Pre-Delivery Checklist.

IMPORTANT: Very low cutting heights should be avoided. Damaging shock loads occur when the blades strike the ground repeatedly. This can cause damage to the mower.

Cutting lower than 2" under most circumstances should be avoided.

The cutting height is adjustable from 1" to 5".

A front anti-scalping roller is also available upon request. This accessory is particularly helpful when cutting over uneven terrain ⁴.

Fig. 5

The cutting height is adjusted by moving the height adjustment spacers on the wheel yokes above or below the wheel arm.

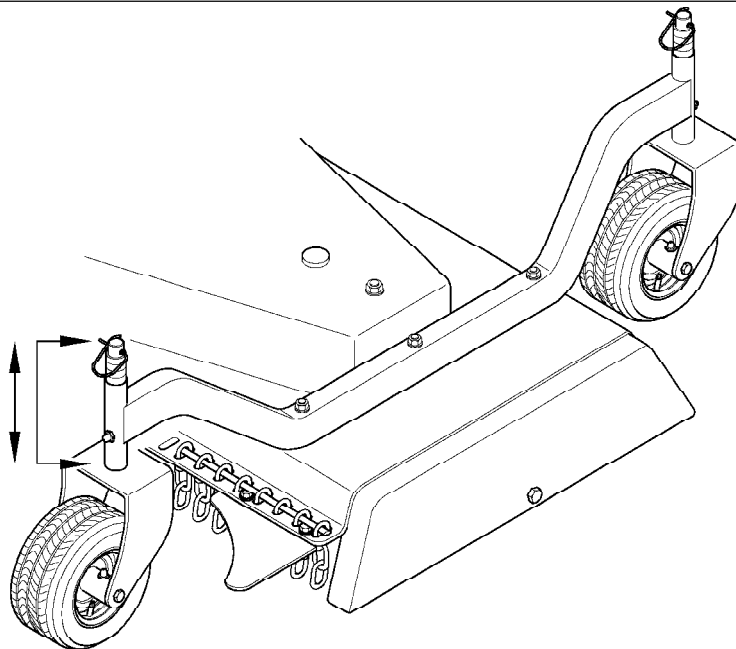

3.04 - Pre-Operational Check

IMPORTANT: Check each of the following, carefully, prior to engaging the equipment:

1. The spindle bearings have been greased.
2. The belts for proper tension.
3. The oil in the gearbox.
4. The driveline cross and bearings have been greased.
5. No wrappings or foreign objects are around the blades, belts or driveline.
6. The blades are properly installed and the blade bolts properly torqued ⁵.
7. All hardware is tight.
8. The tractor, to ensure correct direction of PTO and rpm speed.
9. All safety shields and guards are in place and tightly attached.
10. No people or animals are in the work area.
11. When working, make sure the tractor hitch is in the "float" position, in order to allow the mower to follow the contour of the ground.

⁴ The GM2084 mower comes standard with the front anti-scalping roller.

⁵ See Table 1, page 31.



DANGER: Stay clear of rotating driveline. Entanglement in rotating driveline can cause serious injury. Disengage PTO, engage parking brake or place transmission in "Park", shut off the tractor and remove the key before working around hitch, attaching or detaching driveline, making adjustments, servicing or cleaning the machine.

3.05 - Attaching to the Tractor

Unit may be used on tractors ranging from 20 to 50 HP equipped with a standard PTO and category 1 three point hitch⁶. **Never use this mower with tractors over 50 HP.**



CAUTION: Check the tractor PTO rpm to ensure it is set at 540 and turns clockwise.



CAUTION: Always ensure that the tractor tire pressure is correct according to the tractor operator's manual.



DANGER: Failure to ensure a secure coupling of the implement to the tractor can cause injury and damage to the implement or tractor.

To attach the mower to the tractor do the following:

1. Back the tractor up to the mower in order to slip the tractor hitch arms over the hitch pins welded to the mower hitch arms. **Turn off the tractor engine.** Secure them in place with the lynch pins.
2. Adjust the tractor sway blocks or chains to remove all side movement.
3. Attach the top link. Adjust tractor top link to allow the mower to follow the ground contour and yet remain as level as possible when raised to transport position.
4. Install the shielded driveline to the tractor by first lining up the splines and depressing the snap pin. Push the yoke onto the PTO shaft as far as it will go. Release the pin and pull back slowly until the pin clicks in place. Repeat this operation on the implement end.
5. Attach the driveline chains to the tractor and to the mower to keep the driveline protection from turning. The chains should not be too tight.

⁶ See Table 2, page 31.

3.06 - Start Up



DANGER: The mower must always be lowered to the ground before starting tractor engine or engaging PTO lever.

Lower mower to the ground with the tractor rock shaft control lever. With the engine idling, slowly engage the PTO drive. Move the throttle lever until the PTO speed indicated on the mower is obtained.

The mower is set for a PTO speed of 540 rpm.

Shift the transmission to a slow speed gear and start forward, increase the ground speed by shifting upward until the desired speed is obtained. Do not mow in reverse unless absolutely necessary and only after careful observation of the area behind the mower.



CAUTION: Do not operate this mower at a PTO speed or direction of rotation other than that shown on the mower. Serious damage can occur to the machine and/or the operator.

Before starting to mow, never forget that the **operator is responsible** for the following:

1. Safe and correct driving of the tractor and mower.
2. To learn precise safe operating procedures for both the tractor and the mower.
3. To ensure all maintenance and lubrication has been performed on the mower.
4. To have read and understood all safety aspects for the mower in the operator's manual.
5. To have read and understood all safety decals on the mower.
6. Checking the condition of the blades. Worn or damaged blades should be changed before starting⁷.
7. Checking to ensure that the cutting edge is the leading edge of the blade⁸.
8. Checking that there is no wire, weed, grass or other material wrapped around blades.
9. Checking to see if front weights need to be added to the tractor in order to maintain balance.
10. Checking the tractor tires for the proper pressure in accordance with the tractor operator's manual.
- 11. Checking that the PTO shield, belt shields and all other shielding are on the machine and securely in place.**
12. Making sure the proper attire is worn. Avoiding loose fitting clothing which can become entangled. Wearing sturdy, tough-soled work shoes and protective equipment for eyes, hands, ears and head. Never operate tractor or implements in bare feet, sandals or sneakers.

⁷ See Section 4.03 - Blade Maintenance.

⁸ See Section 4.03 - Blade Maintenance.

13. Checking area for stones, branches and other debris that might be thrown.
14. Ensuring proper lighting is available, sunlight or good artificial lighting.

3.07 - Working Speed

The mowing speed depends on ground conditions, tractor HP, mowing height, and grass thickness. Only a test run will enable you to gauge the optimal working speed for your conditions. Under most conditions a 3 to 8 mph ground speed is best. As a rule of thumb, and if the conditions permit, grass dispersion is increased by higher ground speeds.

In order to obtain the best cut possible, always keep the tractor rpm up to the speed indicated on the mower. When increasing or decreasing mowing ground speed, always use gear selection, not engine speed. This will maintain the constant maximum blade speed necessary for a clean cut.

The mulching kit is an option available for our mowers. This kit, containing 3 multilevel cutting edge blades and add-on containment baffling which bolts to the underside of the mower deck, mulches and pulverizes grass and leaves.

Another benefit of the mulching kit is safety. In fact, the kit greatly reduces the possibility of thrown objects. This is particularly important when mowing around schools, public parks and golf courses. If you are using a **mulching kit**, you need to reduce your ground speed to under 2 mph (see fig. 6).

Fig. 6

The mulching kit is an available option, consisting in 3 multilevel cutting edge blades and add-on containment baffling which bolts to the underside of the mower deck, to mulch and pulverize grass and leaves.

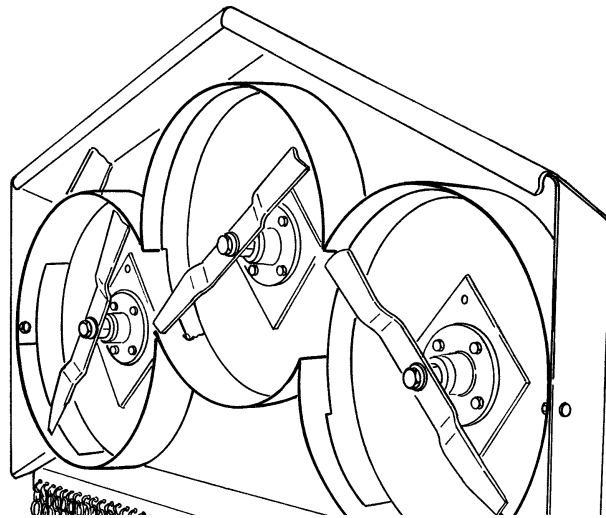

3.08 - Operating Techniques

All of the following factors are important in selecting the proper forward speed:

1. Height of grass.
2. Type of grass.
3. Density of grass.
4. Type of terrain.

5. Grass condition, wet or dry.

This mower has been designed to cut grass with heights from 4" to 8". It is recommended to avoid cutting grass taller than 10". For the best results, try cutting the grass at least once per week during growing season. Tall, dense grass should be cut at low speed, while thin medium grass can be cut at a faster ground speed. For cleaner cuts and efficient mowing, the blades must be kept sharp⁹.

Always operate PTO at 540 rpm. This is necessary to maintain proper blade speed and obtain a clean cut.

Under certain conditions, tractor tires may roll some grass down and prevent it from being cut at the same height as the surrounding area. If this occurs reduce the tractor ground speed but maintain a 540 rpm engine speed. The lower ground speed will permit the grass to at least partially rebound. Under some conditions grass will not rebound enough to be cut evenly, resulting in an uneven appearance. In general, lower cutting height gives a more even cut with less tendency to leave tire tracks. If cut is still not satisfactory, cut the area twice.

Mow extremely tall grass twice. On the first pass use a high cutting height. On the second pass position the mower at the desired height and, when practical, mow at a right angle in travel to the first pass.

Plan your pattern to travel straight forward whenever possible. It is better to cut grass more often, than too short. Short grass deteriorates rapidly in hot weather and invites weed growth during growing season.

If at any time the mower should jam resulting in belt slippage of 2 or more seconds, raise the mower and continue for 2-3 minutes. This will allow the pulleys to cool and prolong belt life.



DANGER: The mower blades can throw objects hundreds of feet which could result in personal or property damage.

Pick up all rocks and other debris before mowing.

Enter new areas carefully. Cut grass higher at first, allowing mower to clear hidden objects.



CAUTION: For emergency reasons learn how to stop the tractor and mower quickly. On the finishing mowers always disengage the PTO, lock parking brake, stop engine and allow the mower blades to come to a complete stop before dismantling the tractor.

⁹ See Sharpening Blades in Section 4.03 - Blade Maintenance.

3.09 - Uneven Terrain



DANGER: Be careful of rollover when operating tractor and mower over uneven ground.

The following precautions should always be observed when working on uneven terrain:

1. In extremely uneven terrain rear wheel weights, front tractor weights, and/or tire ballast should be used to improve stability.
2. Observe the type of terrain and develop a safe working pattern.
3. Whenever traction or stability is doubtful, first test drive over the terrain with the PTO disengaged.
4. Operate the implement up and down steep slopes, not across slopes, to prevent the tractor from tipping. Avoid sudden stops and starts, and slow down before changing directions on a slope.
5. Pass diagonally through sharp dips and avoid sharp drops to prevent hanging up the tractor and implement.
6. Slow down on sharp turns and slopes to prevent tipping or loss of control.
7. Avoid tipping the mower while cutting.
8. Watch for holes, roots or other hidden objects. Do not use near the edge of a gully, ditch or stream bank.

An anti-scalping roller is recommended for uneven ground contours. The roller rides the nose of the mower over a mound to help keep the nose from bulldozing or the blades from scalping the ground.

3.10 - Removing Mower from the Tractor



CAUTION: Disengage tractor PTO. Set parking brake. Stop engine and remove key from ignition. Disconnect mower driveline from tractor PTO shaft. Collapse driveline and store in appropriate place. Disconnect three point linkage and carefully drive tractor away from mower.

3.11 - Transport

Before raising the mower for transport, the tractor top link must be adjusted so when lifted, the rear of the machine is higher than the front (the mower's nose is tilted downward). To do this, shorten the tractor top link until the top hitch plate is locked forward and no longer able to pivot. This will keep the mower locked in position and minimize the shaking and bouncing during transport which can damage the hitch or frame.

When raising the mower be sure the PTO driveline does not hit either the mower or the tractor. During transport the mower should not be lifted over 14"-16" from the ground.



CAUTION: Make sure PTO is disengaged and blades have stopped turning before raising mower to full transport position.

Do not tow tractor and mower behind other vehicles. Use a properly equipped trailer with heavy tie-downs for towing operations.

Before transporting:

1. Disengage PTO.
2. Shorten tractor top link until top hitch plate is locked.
3. Raise machine and lock rockshaft control lever.
4. Always select a safe ground speed that is appropriate for the terrain.
5. Beware of traffic on public roads. Install a SMV (Slow Moving Vehicle) sign when traveling on roads or streets.
6. Reduce ground speed when turning and take care that the mower does not strike obstacles such as trees, fences or buildings.

3.12 - Quick Hitch Adapter Assembly and Operation

Using a iMatch/Quick Hitch system: The GM20 series mowers can be used with a Quick Hitch system, allowing for quick and easy hookup, by installing an optional adapter. This optional adapter has floating yokes that will allow the mower to follow the contour of the ground.



WARNING: When using a Quick Hitch on a PTO driven implement always ensure there is the proper driveline overlap prior to use. If there is not the minimum 6" driveline overlap do not use and contact your nearest dealer to purchase a longer driveline.

Quick Hitch Adapter assembly (see fig. 7):

1. Remove lower hitch arms from grooming mower's linking plates.
2. Remove bolt M16x140 on top of the three point hitch of the grooming mower.
3. Remove bolts M16x45 that hold the top hitch supports to the linking plates of the mower.
4. Install the floating yokes of Quick Hitch Adapter assembly to the linking plates of the mower using the hex bolts M16x65 and the stover nuts M16. Install the floating yokes in the same hole that the hitch pins were mounted. **NOTE: When installing the quick hitch adapter on the GM2084, the floating yokes need to be installed on the opposite side than the other models. Install the left yoke on the right side and the right yoke on the left side of the mower (see fig. 8).**
5. For proper operation of the mower, ensure that the floating yokes are parallel to the ground.

6. Install the floating top link to the top hitch arms using the bolt M16x110 and the stover nut M16.
7. Install the A-frame support to the floating top link using the same bolt M16x140 that was previously removed from the top of the three point hitch of the grooming mower and the stover nut M16.
8. Install the A-frame support to the floating yokes using the hex bolt M20x160 and the stover nut M20.
9. Loosen the bolts M16x45 that secure the top hitch arms to the rear support plates of the mower. Only loosen slightly. The arms must be able to move slightly up and down.
10. Tighten all hardware, ensuring all bolts and nuts have enough play to allow quick hitch adapter to move up and down.

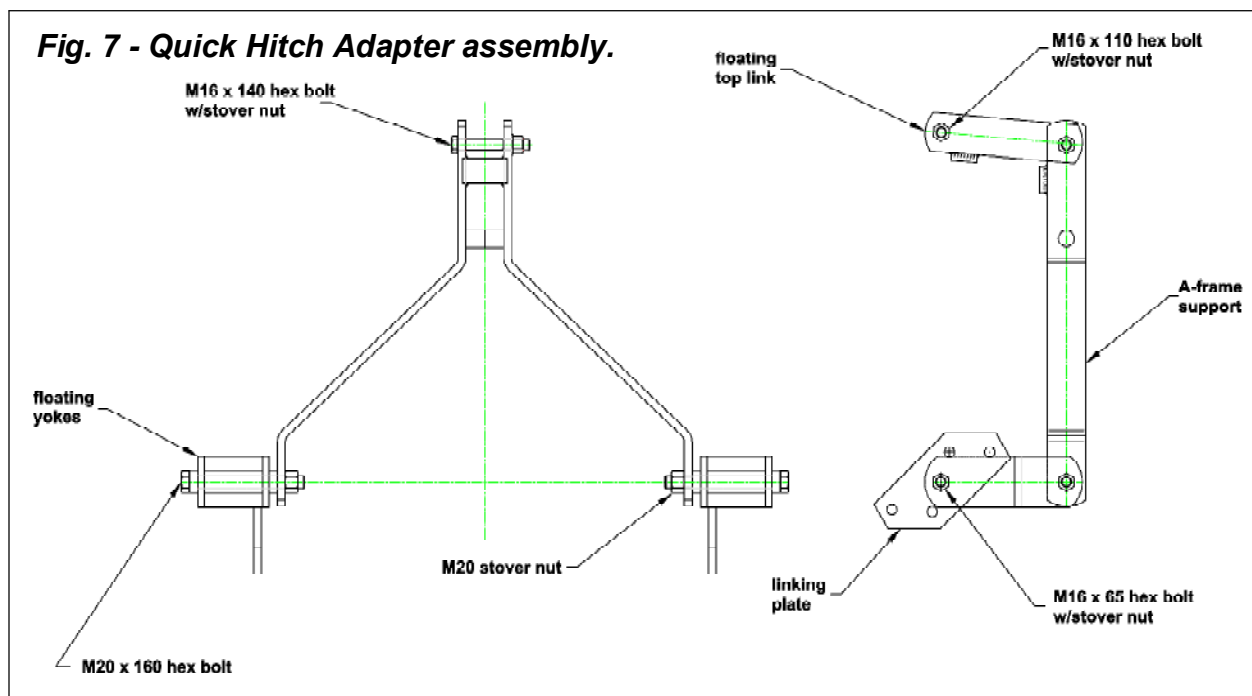

Quick Hitch Adapter operation:

After completing assembly of the adapter, the tractor lift arms should be raised and locked in a position so the floating yokes are horizontal.



CAUTION: Improper setup of the Quick Hitch Adapter can result in equipment damage. A replacement driveline must generally be installed to prevent injury or equipment damage when using the Quick Hitch Adapter.



CAUTION: If the three point hitch of the tractor is set in the lowest position, the driveline may bottom out against the Quick Hitch resulting in a bent driveline. If

the mower is lifted after the driveline has been bent, it may also damage the gearbox, mounting plates, and other hardware.

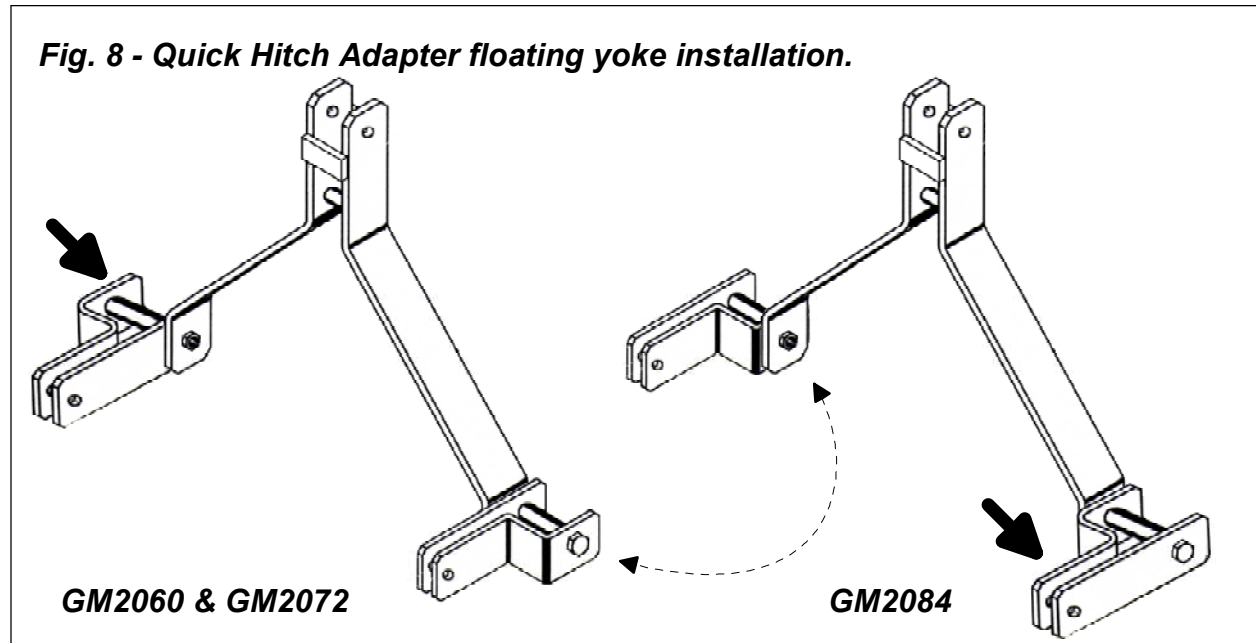

4 - MAINTENANCE



DANGER: Stop engine, lock parking brake and remove key before performing any service or maintenance.

Never rely on the tractor lift system. Install blocks or stands under the mower deck to prevent it from falling.

Always use personal protection devices, such as glasses or gloves when performing maintenance.

Keep fingers out of slots to prevent injury.

4.01 - Maintenance Safety



1. Good maintenance is your responsibility.
2. Keep service area clean and dry. Be sure electrical outlets and tools are properly grounded. Use adequate light for the job at hand.
3. Make sure there is plenty of ventilation. Never operate the engine of the towing vehicle in a closed building. The exhaust fumes may cause asphyxiation.
4. Make no repair or adjustments with the tractor engine running. Before working on the machine, disengage the PTO, shut off the engine, set the brakes, and remove the ignition key.
5. Be certain all moving parts on attachment have come to a complete stop before attempting to perform maintenance.
6. Never work under equipment unless it is blocked securely.
7. Always use personal protection devices such as eye, hand and hearing protectors, when performing any service or maintenance.
8. Frequently check mower blades. They should be sharp, free of nicks and cracks and securely fastened.
9. Periodically tighten all bolts, nuts and screws and check that all cotter pins are properly installed to ensure unit is in a safe condition.
10. When completing a maintenance or service function, make sure all safety shields and devices are installed before placing unit in service.
11. Do not attempt to mount a tire unless you have the proper equipment and experience to do the job.
12. Inflating or servicing tires can be dangerous. Whenever possible, trained personnel should be called to service and/or mount tires.
13. After servicing, be sure all tools, parts and service equipment are removed.

14. Never replace hex bolts with less than grade five bolts unless otherwise specified, i.e. shear bolts¹⁰.
15. Where replacement parts are necessary for periodic maintenance and servicing, genuine replacement parts must be used to restore your equipment to original specifications. The company will not claim responsibility for use of unapproved parts and/or accessories and other damages as a result of their use.
16. Unauthorized modifications to the machine may impair the function and/or safety of the machine and reduce its life. If equipment has been altered in any way from original design, the manufacturer does not accept any liability for injury or warranty.

4.02 - Service

The accompanying illustrations show lubrication points. The chart gives the frequency of lubrication in hours, based on normal operating conditions. Severe or unusual conditions may require more frequent lubrication.

Use a good quality SAE multipurpose type grease for all locations shown. Be sure to clean fittings thoroughly before using grease gun.

Use 90 wt. gear oil in gearbox.

Hourly:

1. Check the condition of mower blades for nicks or dull edges. Sharpen if necessary.
2. Replace bent or damaged blades¹¹.
3. Also check blades for damage after hitting an obstruction.
4. Clean foreign material from mower deck and belt area.

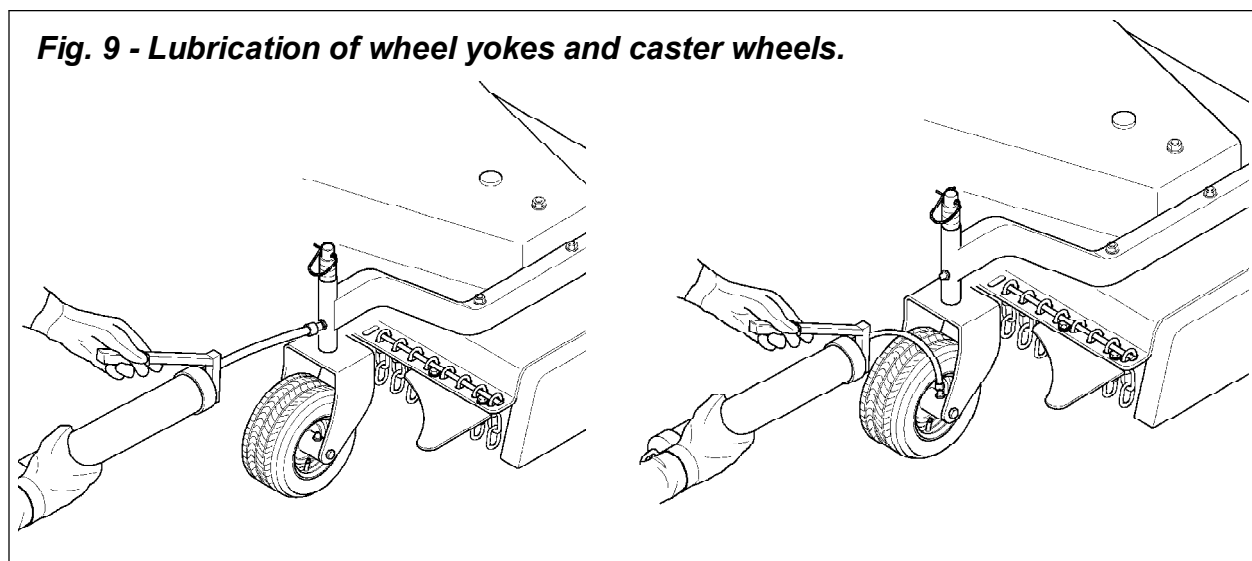

Every 8 hours:

1. **Lubricate the driveline and the wheel yokes:** Apply two or three shots of grease to the driveline cross and bearings and the telescoping shafts; apply the same

¹⁰ Refer to Table 1 - Torque Specifications, page 31.

¹¹ See Section 4.03 - Blade Maintenance.

amount to the wheel arm grease fittings (**see fig. 9**). See the driveline manufacturer operator's manual for further information on the driveline.

2. **Gearbox oil level:** Check gearbox oil level, it should be between $\frac{1}{2}$ and $\frac{2}{3}$ full. If needed add either SAE 90 wt. or SAE 140 wt. gear oil.

Every 25 hours: Check hardware tightness; mower vibrations can loosen bolts. Check tightness of the hardware periodically, using **Table 1** as a guide¹².

Every 50 hours:

1. Lubricate the three spindles with two or three shots of multipurpose grease (**see fig. 10**). The top grease fittings are easily accessible from the top of the deck by simply removing the plastic dust guards.
2. Check belt tension¹³.

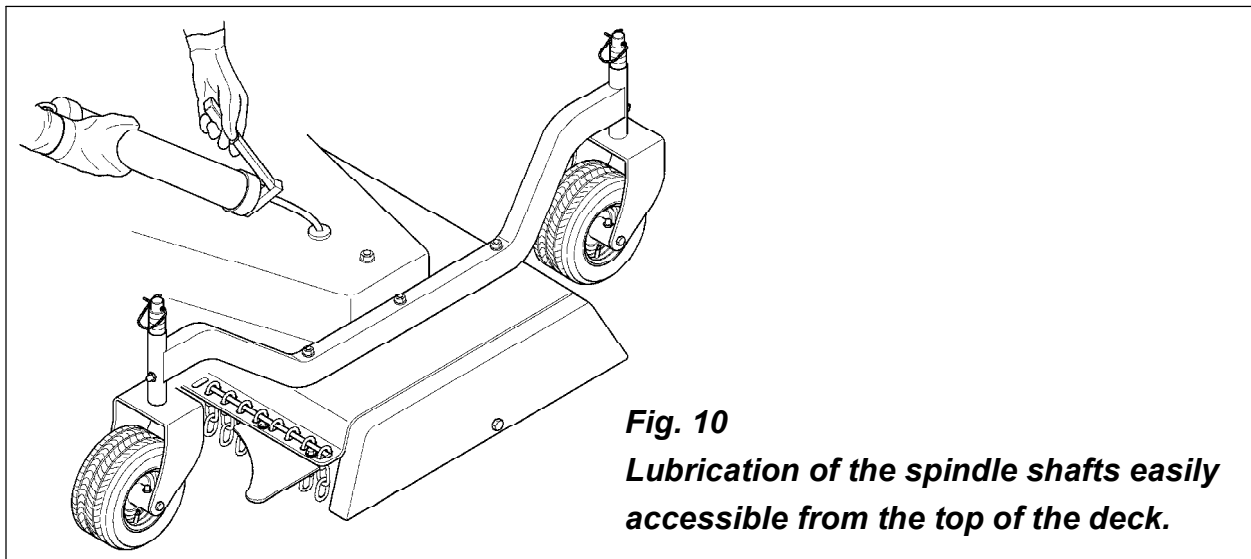

4.03 - Blade Maintenance



WARNING: To avoid possible injury always wear proper eye and hand protection when servicing mower blade.

In order for the mower to work properly, and to always obtain a precision cut with lower HP requirements thus keeping cost down, proper blade maintenance is important. Blades must be kept sharp, at their original length and corners maintained. A blade must be replaced if, due to wear or damage, its original shape has been distorted.

Installing or removing blades

If the mower blades need to be installed, do the following:

¹² See Table 1, Torque Specifications, page 31.

¹³ See Section 4.04 - Belt Tension.

1. The blade turns in a **counter clockwise** direction when viewed from the bottom of the deck. The cutting edge must be towards the direction of rotation. The lift wing of the blades is closest to the deck and the cutting edge away from it (**see fig. 11**).
2. Install the cup washer (**see fig. 11**) over the blade bolt and secure the blade in place as described above.
3. With a wrench, block the spindle and tighten the bolt to 103 lb. ft. (**see fig. 12**).
4. To remove the blades reverse the procedure.

Mower's spindle assembly.

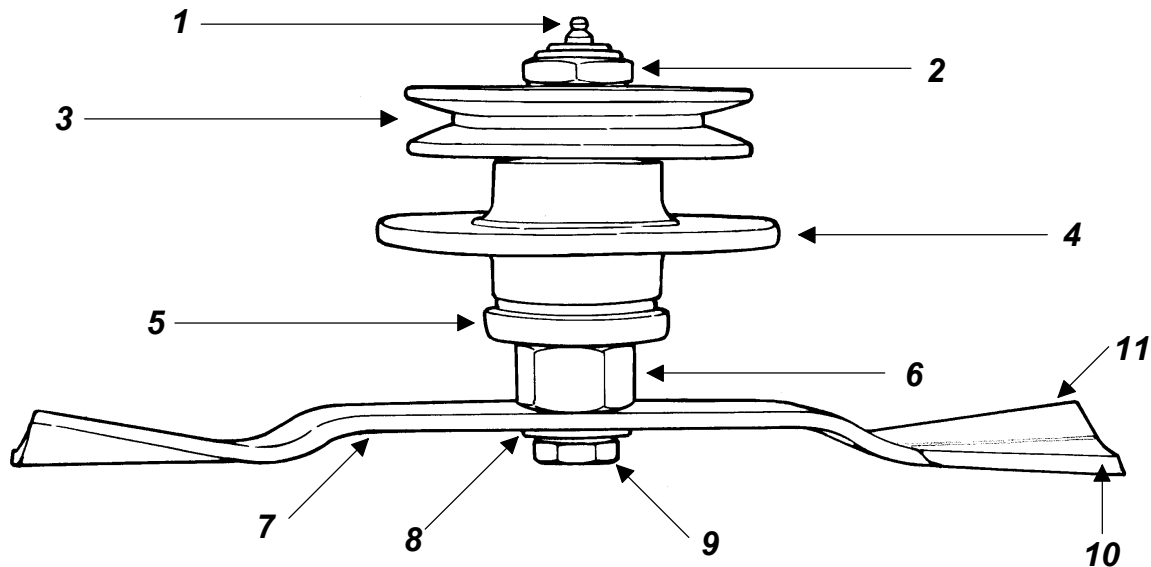

Fig. 11

1. grease fitting
2. hexagonal nut
3. pulley
4. rotor support
5. cover
6. shaft

7. blade
8. cup washer
9. blade bolt
10. cutting edge close to ground
11. lift wing

Ground



WARNING: Do not substitute blades or any bolt for the blade retaining bolt. Company blades and blade retaining bolts are specially made for this application. Using non original parts can effect the quality of cut and may also cause damage to the mower.



DANGER: Proper torque must be used when tightening the blade retaining bolt. If these safety precautions are not followed, the blade could come off during operation and be thrown hundreds of feet from the mower.

Sharpening blades

Blade sharpening is extremely important in order to get the best cutting results. Sharp blades permit a high quality cut and also reduce HP thus lowering cost.

To sharpen blades, first remove them following the above instructions.

Place the blade in a vise and sharpen them by using a hand file or grinder. **Do not sharpen the blades to a sharp cutting edge.** The cutting edge should be between $\frac{1}{64}$ " to $\frac{1}{32}$ " to prevent excessive pitting and dulling of the blades. Sharpen both ends of the blade equally for balance and always maintain corners. Always keep all three blades sharpened equally in order to maintain balance.

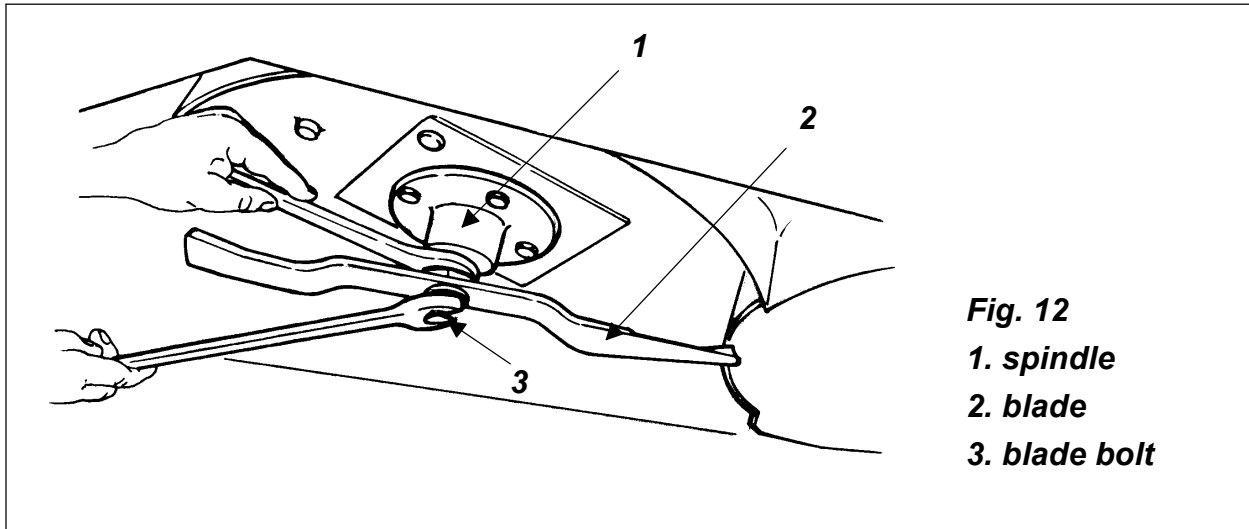

Fig. 12

1. spindle

2. blade

3. blade bolt



CAUTION: Unbalanced or warped blades can cause damage to the mower and/or personal injury. Replace damaged blades before operating the mower. Sharpen both ends of the mower blades equally or until the blade is balanced.

4.04 - Belt Tension

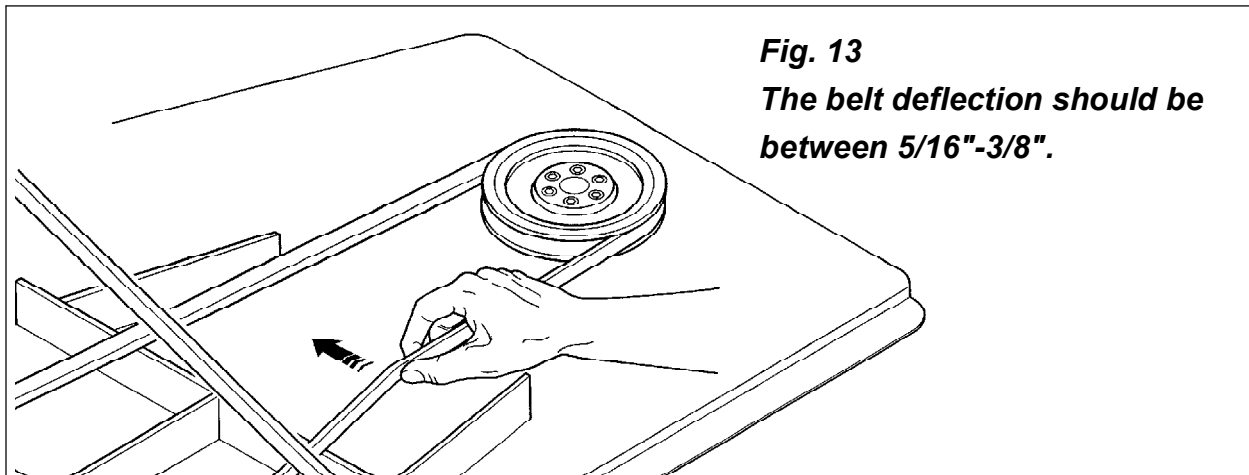

Fig. 13

The belt deflection should be between $\frac{5}{16}$ "- $\frac{3}{8}$ ".

Belt tension control

Check the belt tension (**see fig. 13**) by applying a force of 12-15 lb. pushing against the belt halfway between the pulleys. The belt deflection should be between $\frac{5}{16}$ "- $\frac{3}{8}$ ".

Belt tension adjustment

To adjust the tension do the following (**see fig. 14**):

1. Remove belt shields. Clean foreign material from the mower deck and belt area.
2. Loosen the four nuts holding the gearbox support plate to the central plate.
3. Loosen the two blocking nuts on the adjustment bolt.
4. Turn the adjustment bolt counter clockwise until the proper belt tension is reached.
This will draw the gearbox support plate to the rear, thus tightening the belts.
5. Tighten the two blocking nuts on the adjustment bolt.
6. Retighten the four nuts holding the gearbox support to the central plate.
7. Reinstall the belt shields.

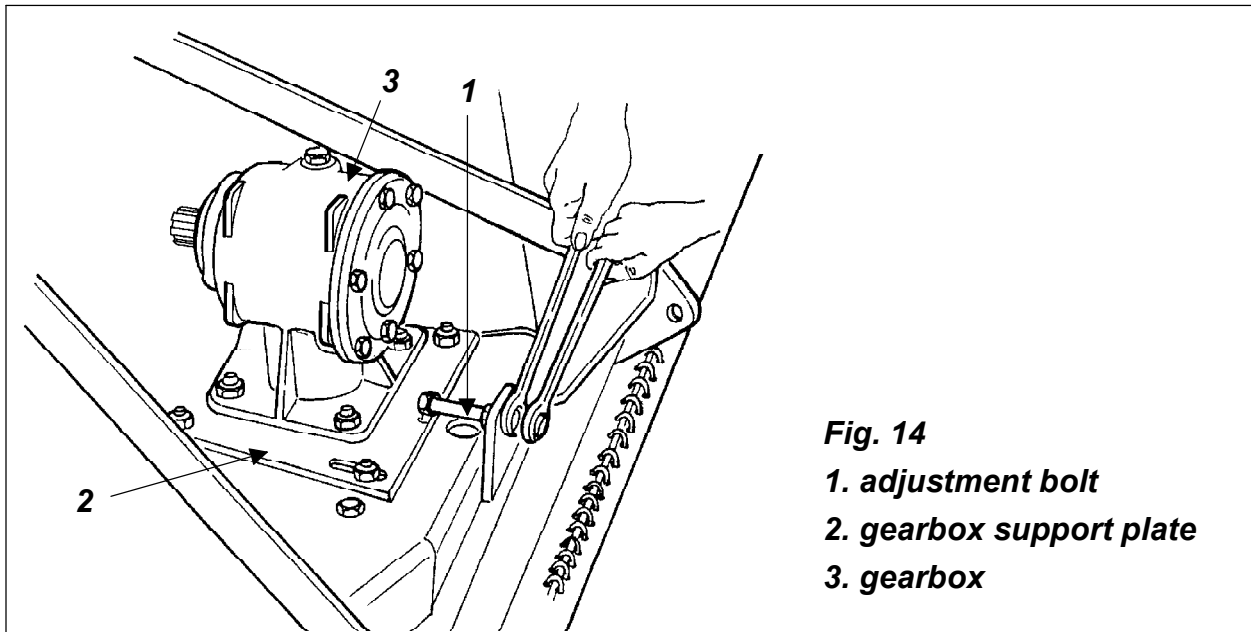

Fig. 14

1. adjustment bolt
2. gearbox support plate
3. gearbox

4.05 - Belt Replacement

If the belts have been stretched or damaged to the point where the proper tension cannot be obtained they must be changed.

To replace belts do the following:

1. Remove belt shields. Clean foreign material from the mower deck and belt area.
2. Loosen the four nuts holding the gearbox support plate to the central plate.
3. Loosen the two blocking nuts on the adjustment bolt.
4. Turn the adjustment bolt clockwise, pushing the gearbox support plate forward until all tension is released (**see fig. 14**).
5. Loosen rear nuts holding central plate (do not remove them).
6. Remove front nuts holding central plate.

7. Lift the front of the central plate and remove old belts.
8. Replace new belts (**see fig. 15**). Loop the first belt over the left spindle and around the lower groove of the center spindle pulley and the lower groove of the gearbox drive pulley. The second belt connects the upper grooves of the center spindle pulley and the gearbox drive pulley with the right spindle pulley.
9. Lower central plate.
10. Replace front nuts. Tighten front and rear nuts holding down central plate.
11. Turn the adjustment bolt counter clockwise until the proper belt tension is reached. This will draw the gearbox support plate to the rear, thus tightening the belts.
12. Tighten the two blocking nuts on the adjustment bolt.
13. Retighten the four nuts holding the gearbox support to the central plate and replace the belt shields.

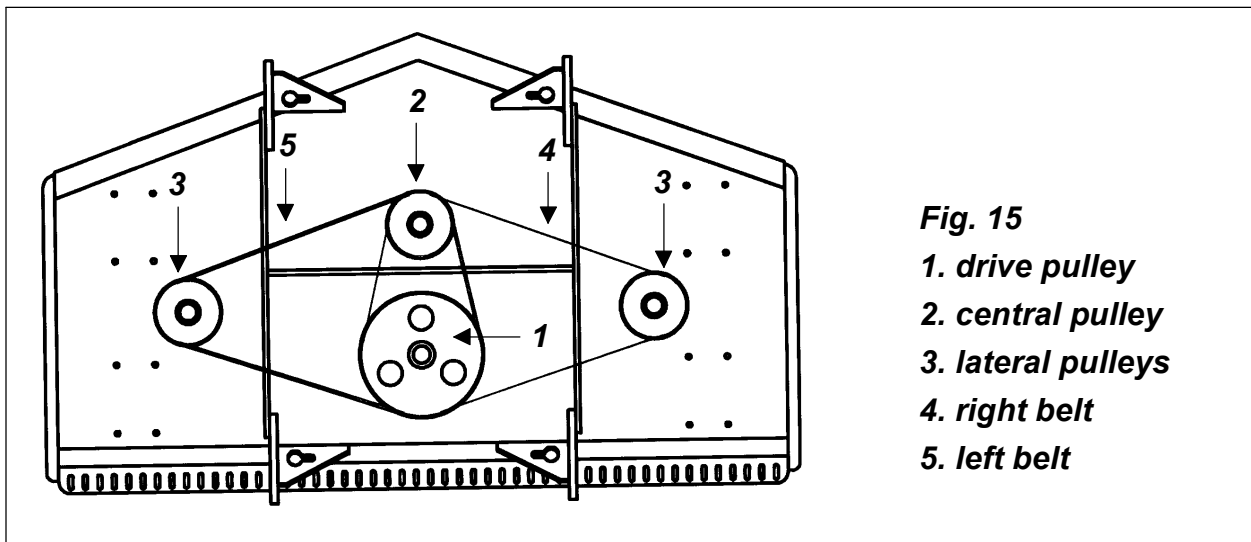

Fig. 15

- 1. drive pulley**
- 2. central pulley**
- 3. lateral pulleys**
- 4. right belt**
- 5. left belt**

4.06 - Driveline



DANGER: Only use the original driveline supplied with this mower and always with the safety shielding. Carefully read and file away the driveline operator's manual supplied by the manufacturer. The following does not substitute the information found in the driveline manual.

IMPORTANT: Always check driveline length during initial setup and when connecting to a different tractor.

In the collapsed position the driveline should be approximately 2" from bottoming out to prevent possible damage to the tractor or implement. When the driveline is in the maximum extended position, the ideal minimum overlap of the two halves should be approximately 6" (**see fig. 16**).

If determined that the driveline is too long, follow these procedures to adjust the length:

1. Separate the two driveline halves. Connect one half to the tractor PTO and the other half to the mower.
2. Raise and lower the mower with the 3 point hitch to find the position where the driveline is shortest. Hold the half shafts side by side and mark the desired length on the outer female tube guard leaving a 1½" gap between the end of the guard tube and bell guard.
3. Cut off both guard tubes the same amount as marked in step 2.
4. Shorten both drive tubes the same amount as guard tubes.
5. De-burr and clean filings from drive tubes and apply grease to outside of inner telescoping tube.
6. Reassemble the driveline halves and connect to tractor and mower. Raise and lower mower again to be sure driveline does not bottom out in its shortest position and has a minimum overlap of 6" in the longest position.
7. Install both driveline safety chains. One should be hooked in a hole on the outer driveline yoke shield and to the tractor to restrict outer shield rotation. The second one should be hooked in a hole on the inner driveline yoke shield and to the implement to restrict inner shield rotation.





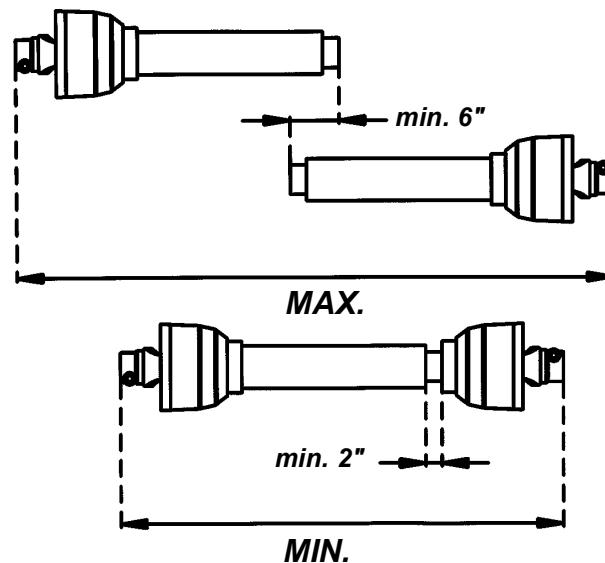

If determined that the driveline is too short for your tractor, contact your local dealer.

Fig. 16



CAUTION: Always work with the driveline as straight as possible. This will prolong its life and that of its components. It is advised not to work at an angle greater than 15 degrees.

TABLE 1 - TORQUE SPECIFICATIONS

Metric (ISO) treaded bolts head marking							Inch (SAE) treaded bolts head marking								
	Class 5.8		Class 8.8		Class 10.9			Grade 2		Grade 5		Grade 8			
Bolt size mm	Thread mm	N.m	ft-lb	N.m	ft-lb	N.m	ft-lb	Bolt size inch	Thread inchi tpi	N.m	ft-lb	N.m	ft-lb	N.m	ft-lb
M5	0.8	4	3	6	4	9	7	1/4"	20	7	5	11	8	16	12
M6	1	6	4	10	7	15	11	1/4"	28	8	6	13	10	19	14
M8	1.25	16	12	25	18	36	27	5/16"	18	15	11	24	17	33	25
M8	1	17	13	26	19	38	28	5/16"	24	17	13	26	19	37	27
M10	1.5	31	23	48	35	71	52	3/8"	16	27	20	42	31	59	44
M10	1.25	33	24	51	38	75	55	3/8"	24	31	23	47	35	67	49
M10	1	35	26	53	39	78	58	7/16"	14	43	32	67	49	95	70
M12	1.75	54	40	84	62	123	91	7/16"	20	48	36	75	55	106	78
M12	1.5	56	41	87	64	128	94	1/2"	13	66	48	102	75	144	106
M12	1.25	59	44	90	66	133	98	1/2"	20	75	55	115	85	163	120
M14	2	84	62	133	98	195	144	9/16"	12	95	70	147	109	208	154
M14	1.5	94	69	142	105	209	154	9/16"	18	106	79	164	121	232	171
M16	2	131	97	206	152	302	223	5/8"	11	132	97	203	150	287	212
M16	1.5	141	104	218	161	320	236	5/8"	18	149	110	230	170	325	240
M18	2.5	181	133	295	218	421	310	3/4"	10	233	172	361	266	509	376
M18	2	196	145	311	229	443	327	3/4"	16	261	192	403	297	569	420
M18	1.5	203	150	327	241	465	343	7/8"	9	226	167	582	430	822	606
M20	2.5	256	189	415	306	592	437	7/8"	14	249	184	642	473	906	668
M20	1.5	288	212	454	335	646	476	1"	8	339	250	873	644	1232	909
M22	2.5	344	254	567	418	807	595	1"	12	371	273	955	704	1348	995
M22	1.5	381	281	613	452	873	644	1-1/8"	7	480	354	1077	794	1746	1288
M24	3	444	327	714	526	1017	750	1-1/8"	12	539	397	1208	891	1958	1445
M24	2	488	360	769	567	1095	808	1-1/4"	7	677	500	1519	1120	2463	1817
M27	3	656	484	1050	774	1496	1103	1-1/4"	12	750	553	1682	1241	2728	2012
M27	2	719	530	1119	825	1594	1176	1-3/8"	6	888	655	1992	1469	3230	2382
M30	3.5	906	668	1420	1047	2033	1499	1-3/8"	12	1011	746	2268	1673	3677	2712
M30	2	1000	738	1600	1180	2250	1659	1-1/2"	6	1179	869	2643	1949	4286	3161
M36	4	1534	1131	2482	1830	3535	2607	1-1/2"	12	1326	978	2974	2194	4823	3557

When using lock washers with nuts, increase torque values by 5%

TABLE 2 - GM2 GROOMING MOWERS - TECHNICAL FEATURES

Series GM2, Rear Discharge, for tractors up to 50 HP, PTO 540 rpm, 3 point hitch cat. 1												
Model	HP	Working width	Overall width	Weight lb.	Rotor rpm/min	Blades tip speed ft/min	# of blades	Cutting height	# of belts & type	# of wheels & size	Driveline 1 3/8"	
GM2060	20-50	60"	62"	534 AT 550 HT	3210	16929	3	1"-5"	2 SPBX	4-11"x4" AT 4-10"x3.2" HT	ASAE 3 rd cat.	
GM2072	20-50	72"	74"	584 AT 600 HT	2605	16732	3	1"-5"	2 SPBX	4-11"x4" AT 4-10"x3.2" HT	ASAE 3 rd cat.	
GM2084	20-50	84"	86"	674 AT 690 HT	2195	16338	3	1"-5"	2 SPBX	4-11"x4" AT 4-10"x3.2" HT	ASAE 3 rd cat.	

5 - REPAIR PROCEDURES



CAUTION: All repair procedures must be done by authorized dealerships. It is not recommended that untrained individuals perform any repair work. The following operations are detailed for qualified personnel only.

5.01 - Gearbox

To remove the gearbox do the following:

1. Remove the belt guards.
2. Loosen the nuts holding the gearbox support plate (**see fig. 14**).
3. Loosen the nut and turn the bolt in order to push the gearbox forward and release tension on the belts (**see fig. 14**).
4. Remove the belts¹⁴.
5. Remove the nuts holding the central plate to the frame.
6. Remove the nut holding the pulley to the gearbox pinion shaft. Remove the pulley.
7. Unbolt the nuts holding the gearbox support plate to the central plate (**see fig. 14**). Remove gearbox and gearbox support plate.
8. Unbolt the nuts holding the gearbox to the gearbox support plate. Remove the gearbox.

If it is necessary to replace any part on the inside of the gearbox, it is important to replace oil seals or gaskets to ensure a tight fit when reassembling.

To replace the gearbox, follow the above instructions in reverse order.

5.02 - Blade Spindle

To remove a blade spindle do the following:

1. Remove the belts¹⁵.
2. Remove the nut holding the pulley to the spindle shaft (**see fig. 11**).
3. Remove the blades¹⁶.
4. Unbolt the bolts holding the rotor support to the mower deck.
5. If necessary remove and replace the bearings from the rotor using presses or extractors.
6. Reassemble in reverse order **ensuring that the nut securing the top pulley (see fig. 11) is tightened to 118 lb.ft.**

¹⁴ See Section 4.05 - Belt Replacement.

¹⁵ See Section 4.05 - Belt Replacement.

¹⁶ See Section 4.03 - Blade Maintenance.

5.03 - Suggested Spare Parts

It is suggested that the following spare parts be kept on hand for the mower at all times to prevent a minor problem from delaying work.

Description	Quantity
Blades	3
Blade bolts	3
Washers	3
Belts	2

5.04 - Storage

After seasonal use it is important to perform the following for prolonged storage:

1. Wash the mower carefully.
2. Inspect the mower and replace worn or damaged parts.
3. Tighten all hardware.
4. Grease all areas indicated under Maintenance ¹⁷.
5. Loosen the belts if the mower is to be stored for an extended length of time.
6. Cover the mower from the elements in order to have it in perfect condition for the start of the next season.

¹⁷ See Chapter 4 - Maintenance.

6 - TROUBLESHOOTING



WARNING: Be sure tractor engine is off, parking brake is locked, and key is removed before making any adjustments.

PROBLEM	POSSIBLE CAUSE	SOLUTION
Uneven cutting.	Cup washer not between blade and bolt. Ground speed too fast. Blades need sharpening. Caster wheels uneven.	Check washer location at all 3 spindles. Shift to lower gear. Sharpen blades. Adjust wheel position.
Blades turning but not cutting.	Direction of blades is wrong.	Blade should turn CCW when you face deck bottom. See Blades Maintenance section.
Belt slippage.	Lack of tension. Object clogging mower. Debris in pulleys.	Tighten belt. Remove object. Clean pulleys.
Mower vibrates.	Object wrapped around blade. Belts damaged.	Remove object. Replace belts.
Belt squeal.	Belts slipping.	Tighten belts.
Grass build up at exit.	Wet grass. Grass too high. Tractor rpm too slow.	Allow grass to dry. Raise mower, shift to lower gear, make two passes over grass. Mow grass high 1st pass, 2nd pass cut to desired height. Increase tractor rpm, check engine and PTO speeds.
Belts are tight when installing.	Wrong belt size. Installed belts incorrectly.	Check belt size. See Replacing Belts section.
Streaking conditions in swath.	Too wet to mow. Blades cannot cut grass pressed down by wheels. Dull blades. Blades worn down, preventing overlap.	Allow grass to dry. Maintain engine speed and shift to lower gear. Sharpen blade. See Blades Maintenance section. Change blades.
Cut grass windrows.	Ground speed too low. Tractor rpm too slow.	Increase ground speed. Increase tractor rpm, check engine and PTO speeds.

7 - PRE-DELIVERY CHECKLIST

To the dealer: Inspect the machine thoroughly after assembly to assure it is functioning properly before delivering it to the customer. The following checklist is a reminder of points to cover. Check off each item as it is found satisfactory or after proper adjustment is made.

- Gearbox oil level.
- Guards and shield properly fastened.
- Lubrication of grease fittings.
- All hardware properly tightened.
- All decals properly located and readable (**see fig. 4**).
- Blades properly installed, blade bolts and nuts tightened.
- Overall condition (touch up scratches, clean and polish).
- Test run, check for excessive vibration or overheating of bearings.
- Operator's Manual.

Review the Operator's Manual with the customer. Explain the following:

- Warranty.
- Safe operation and service.
- Correct machine installation and operation.
- Daily and periodic lubrication, maintenance and inspections.
- Troubleshooting.
- Operational procedures and storage.
- Parts and service.
- Fill out the Pre-Delivery Checklist and on-line Warranty Registration form.
- Give customer the Operator's Manual and encourage the customer to read the manual carefully.

IMPORTANT: The dealer must complete the Warranty Registration, located on the Frontier website. Warranty claims will be denied if the Warranty Registration has not been completed.

Model Number: _____

Serial Number: _____

Delivery Date: _____

Dealer's Signature: _____

GROOMING MOWERS

GM2060

GM2072

GM2084

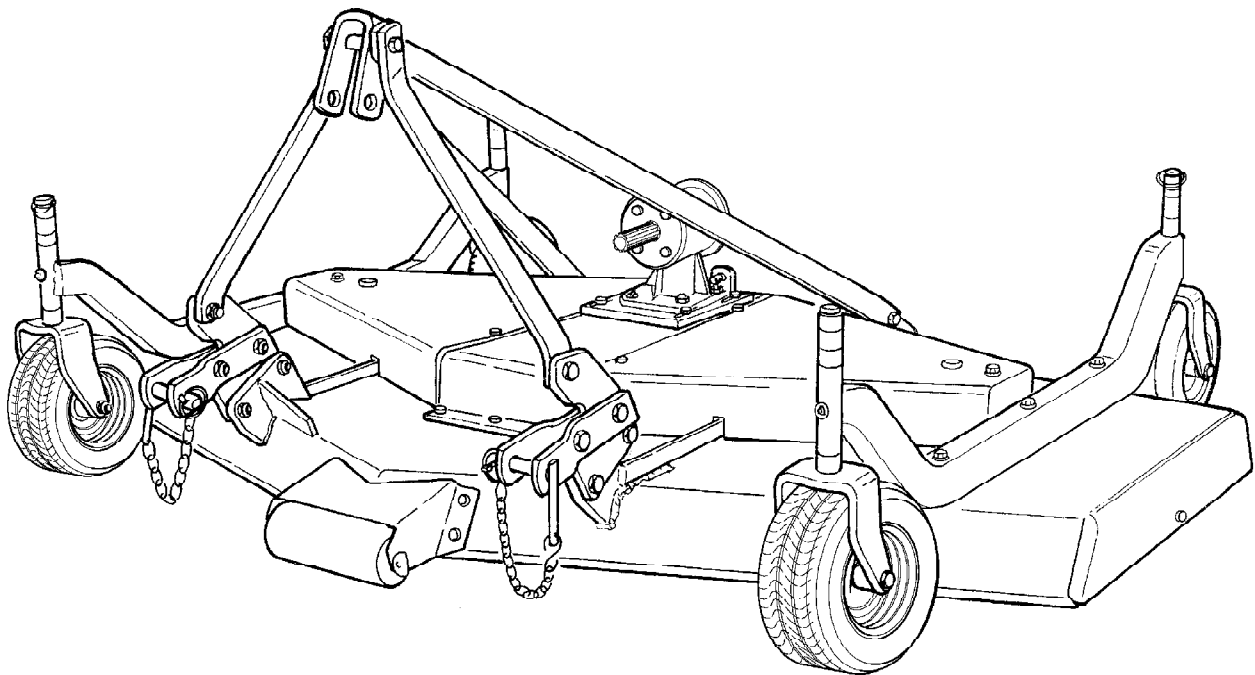

Note: Serial #'s with the XF prefix are subsequent to serial numbers with the BC prefix. For example: A reference to "serial # BC... 739197 & above" will also include all serial numbers with an XF prefix.

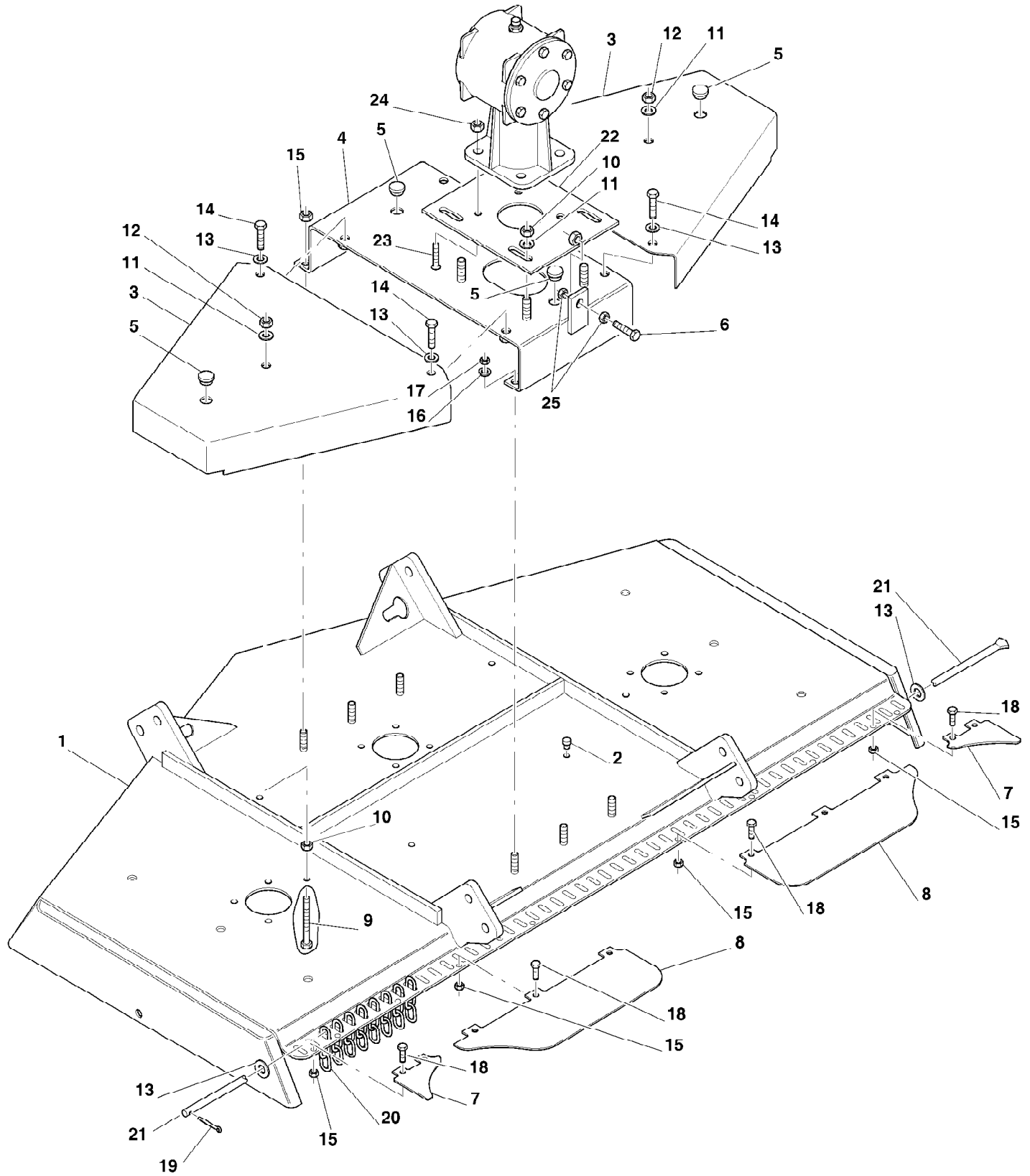

Ref.	Part #	Description	Qty.
1	5BP0220260	Frame GM2060 rear discharge	1
	5BP0320260	Frame GM2072 rear discharge	1
	5BP0420260	Frame GM2084 rear discharge	1
2	5BP0051570	Cap GM2060 & GM2072	8
	5BP0051570	Cap GM2084	4
3	5BP0206989	Belt shield GM2060	2
	5BP0306989	Belt shield GM2072	2
	5BP0406989	Belt shield GM2084	2
4	5BP0006875	Central plate GM2060	1
	5BP0006913	Central plate GM2072	1
	5BP0006814	Central plate GM2084	1
5	5BP0006647	Cap	4
6	5BP0006547	Bolt TE M12x100	1
7	5BP0020411	Side rear protection GM2060	2
	5BP0020412	Side rear protection GM2072	2
	5BP0020413	Side rear protection GM2084	2
8	5BP0020415	Central rear protection	2
9	5BP0006943	Bolt TE M10x120	2
10	5BP0014106	Locking nut M10	6
11	5BP0030157	Flat washer Ø10	6
12	5BP0015237	Locking nut M10	2
13	5BP0002034	Flat washer Ø10	10
14	5BP0033176	Bolt TE M10x25	4
15	5BP0030156	Nut M10	-
16	5BP0001280	Lock washer Ø10	3
17	5BP0001279	Nut M10	3
18	5BP0006349	Bolt TE M10x20	-
19	5BP0044156	Cotter pin Ø4x25	1
20	5BP0006764	Chain GM2060	50
	5BP0006764	Chain GM2072	61
	5BP0006764	Chain GM2084	71
21	5BP0206762	Chain rod GM2060	1
	5BP0306762	Chain rod GM2072	1
	5BP0406762	Chain rod GM2084	1
22	5BP0006541	Gearbox support plate	1
23	5BP0074183	Bolt TSPEI M12x40	4
24	5BP0030064	Nut M12	4
25	5BP0001106	Nut M12	2

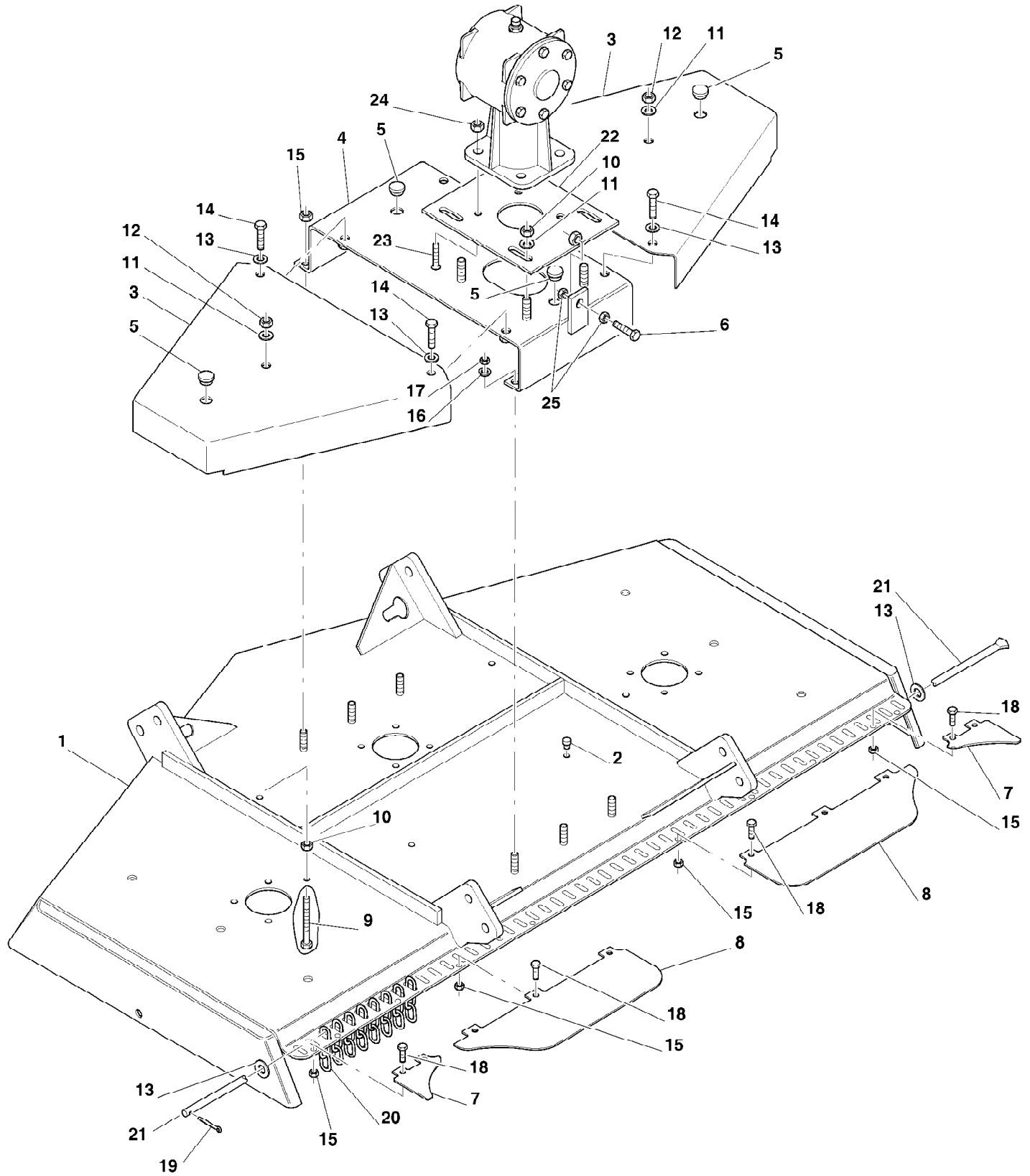

Ref.	Part #	Description	Qty.
	5BP503885B	Mower safety decal set	1
	5BP950109B	Decal "DANGER - Avoid injury from PTO"	1
	5BP950111B	Decal "CAUTION - To avoid serious injury"	1
	5BP950818B	Decal "DANGER - Rotating blades; Thrown objects"	2
	5BP950406B	Decal "WARNING - Falling off"	1
	5BP950407B	Decal "WARNING - Crushing and pinching hazard"	1
	5BP950366B	Red reflective decal	2
	5BP950405B	Yellow reflective decal	1
	5BP950346B	Decal "Frontier"	1
	5BP950400B	Decal "GM2060"	1
	5BP950401B	Decal "GM2072"	1
	5BP950402B	Decal "GM2084"	1
	5BP503853B	Manual holder w/hardware	1
	5BP960384B	Operator's & Parts Manual "GM2060, GM2072 & GM2084"	1

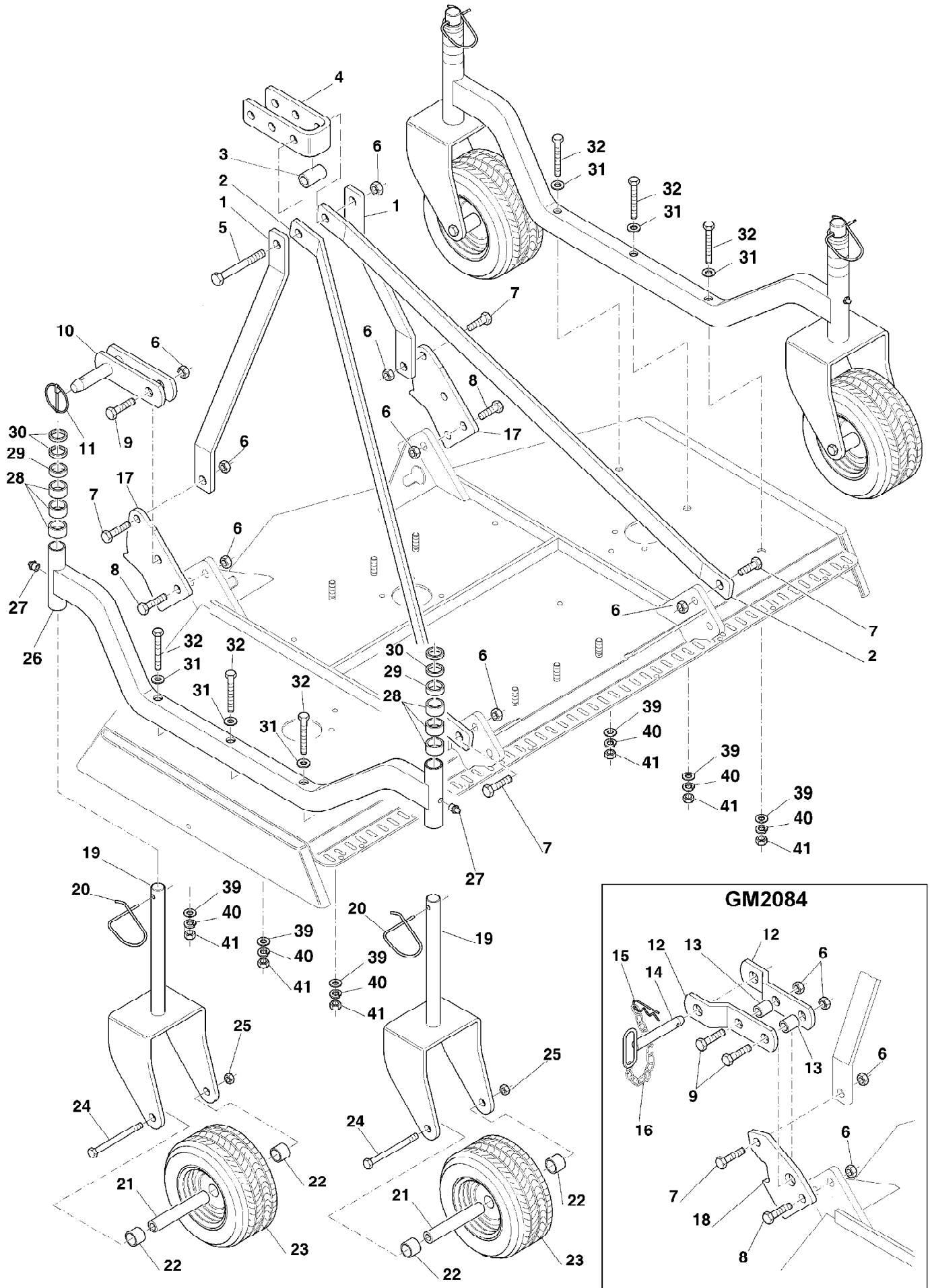

Ref.	Part #	Description	Qty.
1	5BP0006822	Top hitch support GM2060 & GM2072	2
	5BP0006823	Top hitch support GM2084	2
2	5BP0206570	Top hitch arm GM2060	2
	5BP0306570	Top hitch arm GM2072	2
	5BP0006821	Top hitch arm GM2084	2
3	5BP0006829	Spacer	1
4	5BP0006828	Upper plate	1
5	5BP0006891	Bolt TE M16x140	1
6	5BP0005581	Nut M16	-
7	5BP0006578	Bolt TE M16x45	4
8	5BP0002365	Bolt TE M16x50	4
9	5BP0033218	Bolt TE M16x55	-
10	5BP0006573	Hitch block	2
11	5BP0018266	Lynch pin	2
12	5BP0006826	Lower hitch arm GM2084	4
13	5BP0006827	Spacer GM2084	4
14	5BP0038346	Pin GM2084	2
15	5BP0032366	Cotter pin GM2084	2
16	5BP0008506	Chain	2
17	5BP0006540	Linking plate GM2060 & GM2072	2
18	5BP0006854	Linking plate GM2084	2
19	5BP0006946	Wheel yoke	4
20	5BP0008783	Cotter pin	4
21	5BP0006584	Inner spacer	4
22	5BP0006585	Hard tire outer wheel spacer	8
	5BP0006972	Air tire outer wheel spacer; #BC...848686 & above	8
23	5BP0006923Y	Hard tire	4
	5BP0006967	Air tire 11"; #BC...848685 & below ¹⁸	4
	5BP0006964	Air tire 11"; #BC...848686 & above	4
24	5BP0006619	Bolt TE M14x150	4
25	5BP0030358	Nut M14	4
26	5BP0220430	Wheel arm GM2060	2
	5BP0320430	Wheel arm GM2072	2
	5BP0420430	Wheel arm GM2084	2
27	5BP0001065	Grease fitting	4
28	5BP0006586	Spacer 1"	12
29	5BP0006587	Spacer ½"	4
30	5BP0006589	Spacer ¼"	8
31	5BP0051776	Flat washer Ø10	6
32	5BP0026185	Bolt TE M10x90	6
39	5BP0002034	Flat washer Ø10	6
40	5BP0001280	Lock washer Ø10	6
41	5BP0001279	Nut M10	6

¹⁸ Wheel no longer available, part # 5BP0006964 should be ordered instead. Serial # BC...848685 and below must also order two (2) outer wheel spacers (5BP0006972) when replacing wheel.

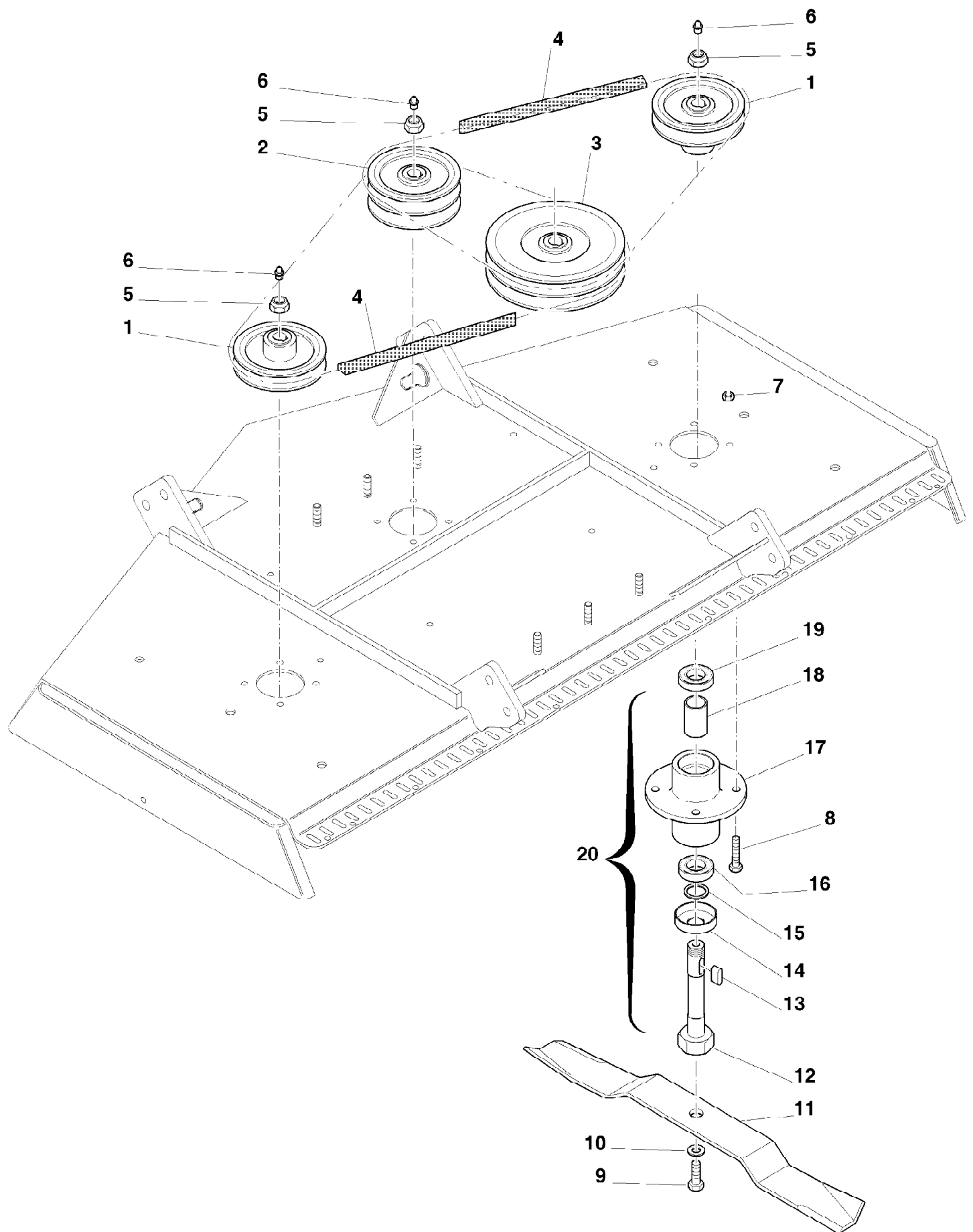

Ref.	Part #	Description	Qty.
1	5BP0006622	Pulley SPB 130x1 GM2060	2
	5BP0006842	Pulley SPB 160x1 GM2072	2
	5BP0006862	Pulley SPB 190x1 GM2084	2
2	5BP0006621	Pulley SPB 130x2 GM2060	1
	5BP0006841	Pulley SPB 160x2 GM2072	1
	5BP0006861	Pulley SPB 190x2 GM2084	1
3	5BP0006692	Pulley SPB 250x2	1
4	5BP0006693	Belt 5VX710 GM2060	2
	5BP0006848	Belt 5VX850 GM2072	2
	5BP0006694	Belt 5VX1000 GM2084	2
5	5BP0006698	Nut M25	3
6	5BP0029036	Grease fitting	3
7	5BP0030156	Nut M10	12
8	5BP0001278	Bolt TE M10x30	12
9	5BP0006659	Blade bolt PGF	3
10	5BP0008560	Disc spring	3
11	5BP0006641	Standard blade GM2060	3
	5BP0006845	Standard blade GM2072	3
	5BP0006690	Standard blade GM2084	3
	5BP0006641M	Mulching blade GM2060 (option)	3
	5BP0006845M	Mulching blade GM2072 (option)	3
	5BP0006690M	Mulching blade GM2084 (option)	3
	5BP0006641B	High Lift blade GM2060 (option)	3
	5BP0006845B	High Lift blade GM2072 (option)	3
	5BP0006690B	High Lift blade GM2084 (option)	3
	5BP0006641F	Flat blade GM2060 (option)	3
	5BP0006845F	Flat blade GM2072 (option)	3
	5BP0006690F	Flat blade GM2084 (option)	3
	5BP0006641G	Gator blade GM2060 (option)	3
	5BP0006845G	Gator blade GM2072 (option)	3
	5BP0006690G	Gator blade GM2084 (option)	3
12	5BP0006649	Spindle shaft	3
13	5BP0006639	Key 8x7x25	3
14	5BP0006636	Cover	3
15	5BP0006606	Spacer washer	3
16	5BP0006626A	Bearing 6205-ZZ	3
17	5BP0006648	Spindle	3
18	5BP0006640	Spacer	3
19	5BP0006634A	Bearing 6205-Z	3
20	5BP0006629	Spindle assembly	-

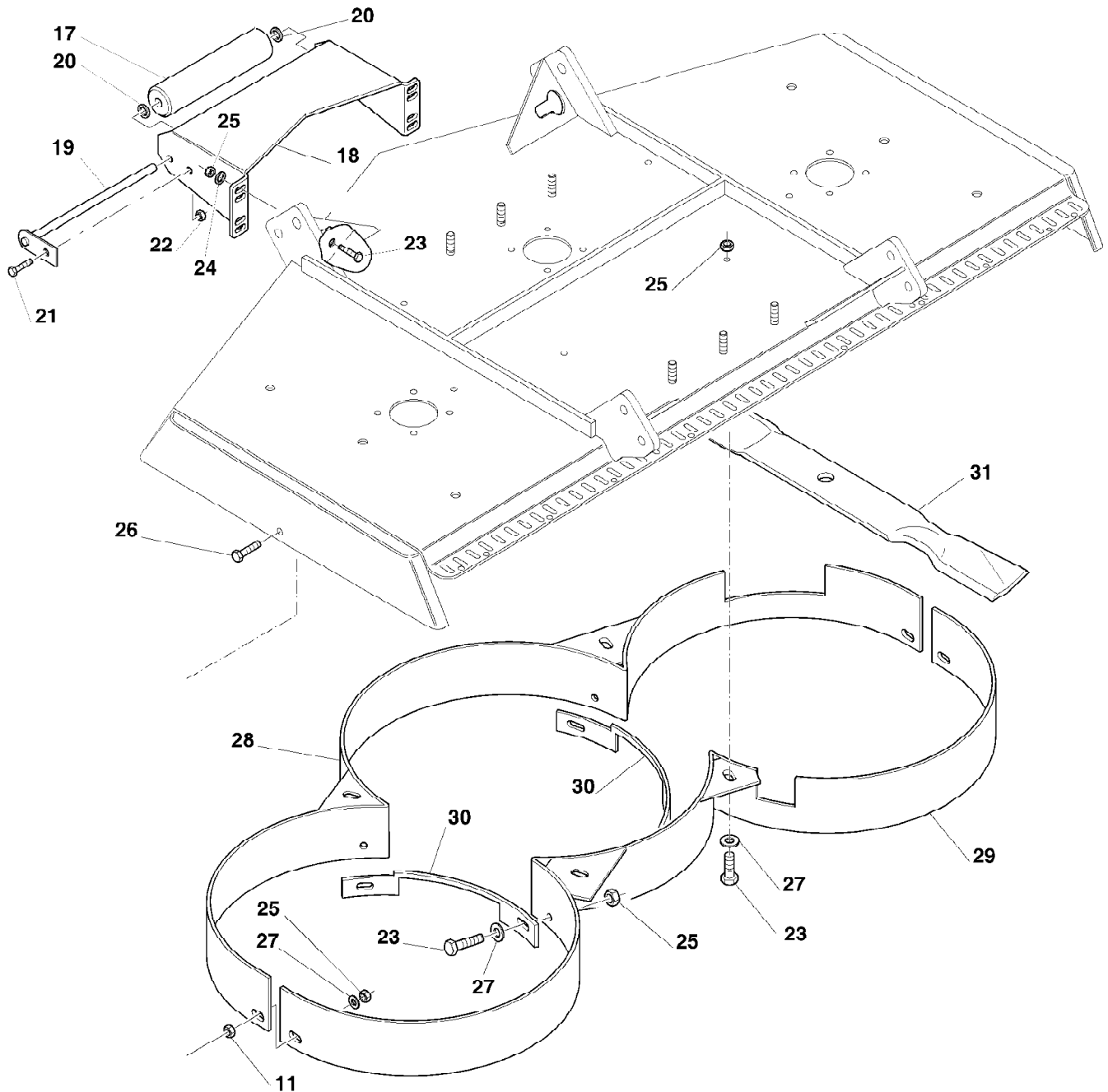

Ref.	Part #	Description	Qty.
11	5BP0003038	Nut M12	6
17	5BP0067358	Front roller	1
18	5BP0009622	Front roller support; serial #BC...847683 & below	1
	5BP0067354	Front roller support; serial #BC...847684 & above	1
19	5BP0067363	Roller pin; serial #BC...847683 & below	1
	5BP0067365	Roller pin; serial #BC...847684 & above	1
20	5BP0008568	Flat washer Ø16	2
21	5BP0046454	Bolt TE M8x16	1
22	5BP0011328	Nut M8	1
23	5BP0006349	Bolt TE M10x20	-
24	5BP0002034	Flat washer Ø10	4
25	5BP0030156	Nut M10	-
26	5BP0091281	Bolt TE M10x35	2
27	5BP0030157	Flat washer Ø10	-
28	5BP0006783	Baffling GM2060	1
	5BP0006784	Baffling GM2072	1
	5BP0006801	Baffling GM2084	1
29	5BP0006777	Baffling GM2060	1
	5BP0006778	Baffling GM2072	1
	5BP0006806	Baffling GM2084	1
30	5BP0006780	Guard support GM2072	2
	5BP0006865	Guard support GM2084	2
31	5BP0006641M	Mulching blade GM2060	3
	5BP0006845M	Mulching blade GM2072	3
	5BP0006690M	Mulching blade GM2084	3

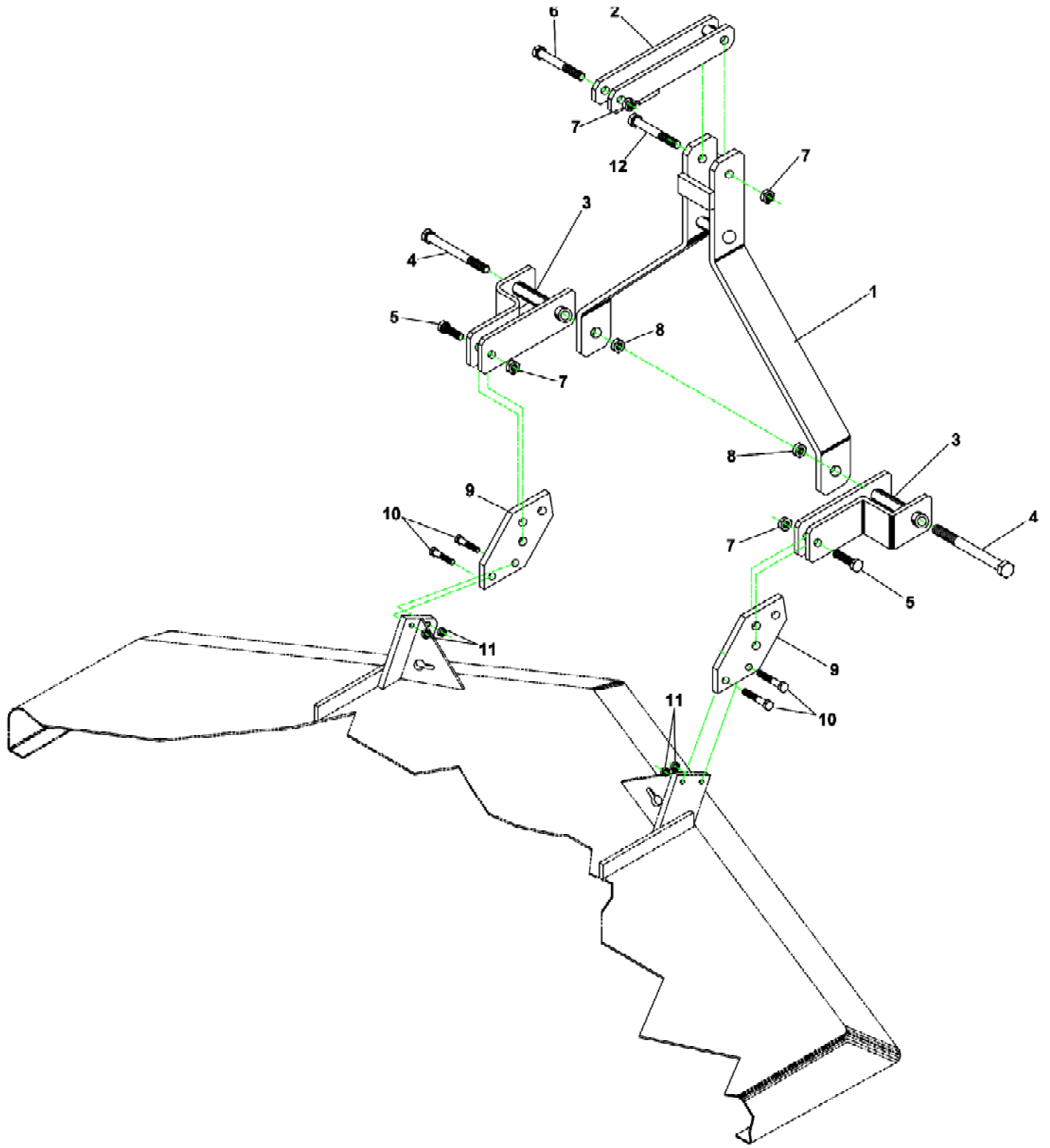

Ref.	Part #	Description	Qty.
1	5BP503816B	A-frame support	1
2	5BP503817B	Floating top link	1
3	5BP503815B	Floating yoke	2
4	5BP503300B	Bolt M20x160	2
5	5BP0009884	Bolt M16x65	2
6	5BP0070346	Bolt M16x110	1
7	5BP0005581	Stover nut M16	4
8	5BP0005507	Stover nut M20	2
9	5BP0006540	Linking plate ¹⁹	2
	5BP0006854	Linking plate GM2084 only ²⁰	2
10	5BP0002365	Bolt TE M16x50 ²¹	4
11	5BP0005581	Nut M16 ²²	4
12	5BP0006891	Bolt TE M16x140 ²³	1
	5BP002800	Quick Hitch Adapter, complete	-
	5BP971214B	GM2 Quick Hitch Adapter assembly manual	1

¹⁹ The linking plates come with the mower and are not part of the Quick Hitch Adapter kit.

²⁰ The linking plates come with the mower and are not part of the Quick Hitch Adapter kit.

²¹ The four (4) bolts (5BP0002365) and (4) nuts (5BP0005581) come with the mower and are not part of the Quick Hitch Adapter kit.

²² The four (4) bolts (5BP0002365) and (4) nuts (5BP0005581) come with the mower and are not part of the Quick Hitch Adapter kit.

²³ This bolt (5BP0006891) comes with the mower and is not part of the Quick Hitch Adapter kit.

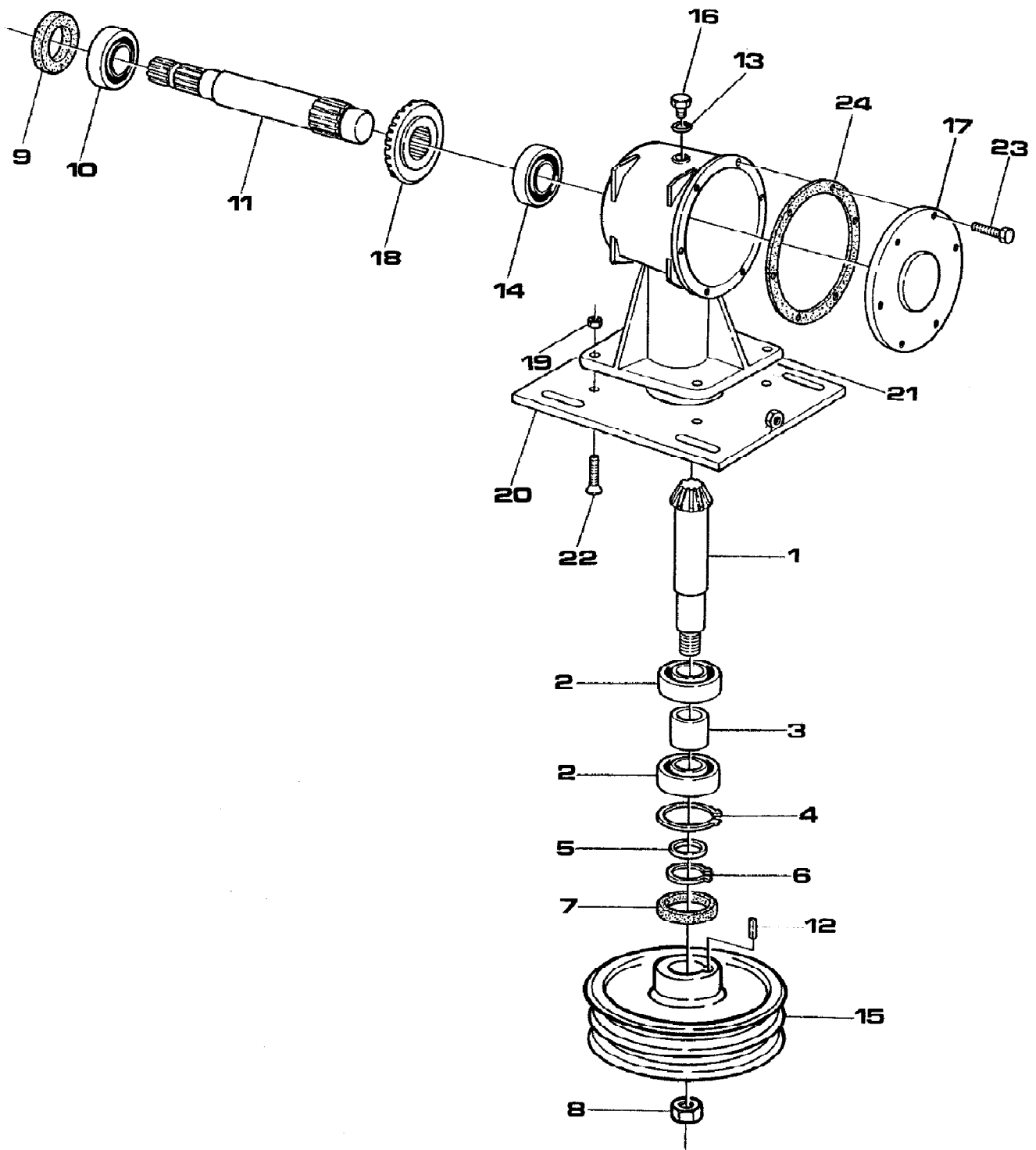

Ref.	Part #	Description	Qty.
1	5BP0058479	Pinion Gear	1
2	5BP0012149	Bearing 6208	2
3	5BP0006687	Spacer	1
4	5BP0001154	Inner snap ring Ø80	1
5	5BP0006685	Spacer washer	1
6	5BP0008138	Outer snap ring Ø40	1
7	5BP0006684	Oil seal 40.80.10	1
8	5BP0006698	Nut M25	1
9	5BP0002295	Oil seal 35.62.10	1
10	5BP0025332	Bearing 6207	1
11	5BP0058464	Input shaft	1
12	5BP0006689	Key 8x7x30	1
13	5BP0006691	Gasket	1
14	5BP0058472	Bearing 30206	1
15	5BP0006692	Pulley SPB 250x2	1
16	5BP0001107A	Breather cap	1
17	5BP0006656	Gear cover	1
18	5BP0058477	Ring gear	1
19	5BP0030064	Nut M12	4
20	5BP0006541	Gearbox support plate	1
21	5BP0006998	Gearbox housing	1
22	5BP0074183	Bolt TSPEI M12x40	4
23	5BP0006349	Bolt TE M10x20	6
24	5BP0030193	Gasket (0.012)	-
	5BP0130193	Gasket (0.028)	-
	5BP0500680	Gearbox complete	-

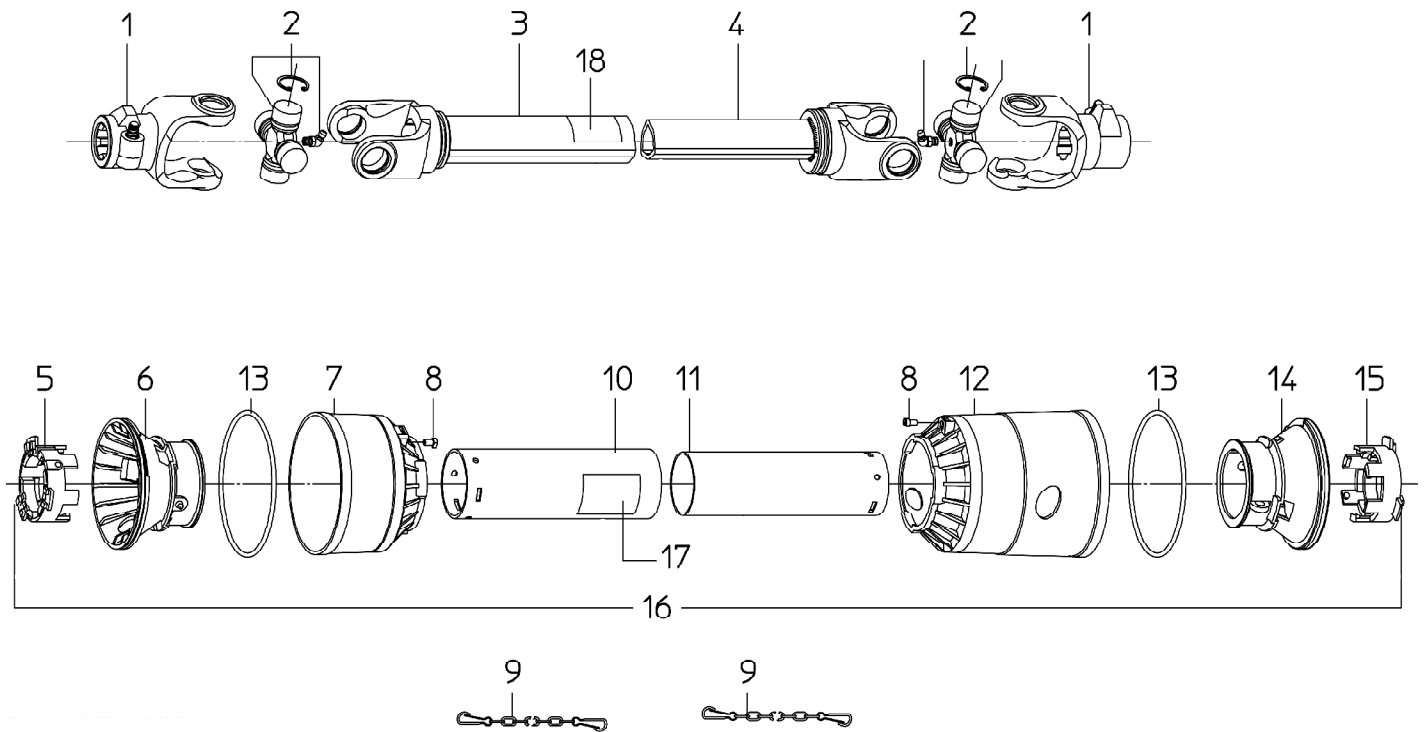

Ref.	Part #	Description	Qty.
1	5BP1023010C	PTO yoke	2
2	5BP1003020C	Cross and bearing	2
3	5BP1943055NC	Outer tube GM2060	1
	5BP1943070NC	Outer tube GM2072, GM2084	1
4	5BP1953057NC	Inner tube GM2060	1
	5BP1953072NC	Inner tube GM2072, GM2084	1
5	5BP1784210C	Outer locking ring; #XF...277830 & below	1
6	5BP1784201C	Outer tube rigid cone; #XF...277830 & below	1
7	5BP1784203C	Standard cone (tractor end); #XF...277830 & below	1
8	5BP1784212C	Pin; #XXX & below	2
9	5BP1006065C	Chain	2
10	5BP1773053C	Female tube shield GM2060	1
	5BP1773068C	Female tube shield GM2072, GM2084	1
11	5BP1872053C	Male tube shield GM2060	1
	5BP1872068C	Male tube shield GM2072, GM2084	1
12	5BP1784205C	Long cone (implement end); #XF...277830 & below	1
13	5BP1213233C	Stiffening ring; #XF...277830 & below	2
14	5BP1784202C	Inner tube rigid cone; #XF...277830 & below	1
15	5BP1784211C	Inner locking ring; #XF...277830 & below	1
16	5BP90SL4053C	Complete shielding GM2060 ²⁴	1
	5BP90SL4068C	Complete shielding GM2072, GM2084 ²⁵	1
17	5BP950463B	Decal "DANGER - Rotating driveline, keep away" outer shield	1
18	5BP950464B	Decal "DANGER - Guard missing, do not operate" outer tube	1
	5BP0500414	Driveline complete GM2060	-
	5BP0500415	Driveline complete GM2072, GM2084	-

²⁴ Complete shielding is interchangeable with part #5BP96SL4053C.

²⁵ Complete shielding is interchangeable with part #5BP96SL4068C.

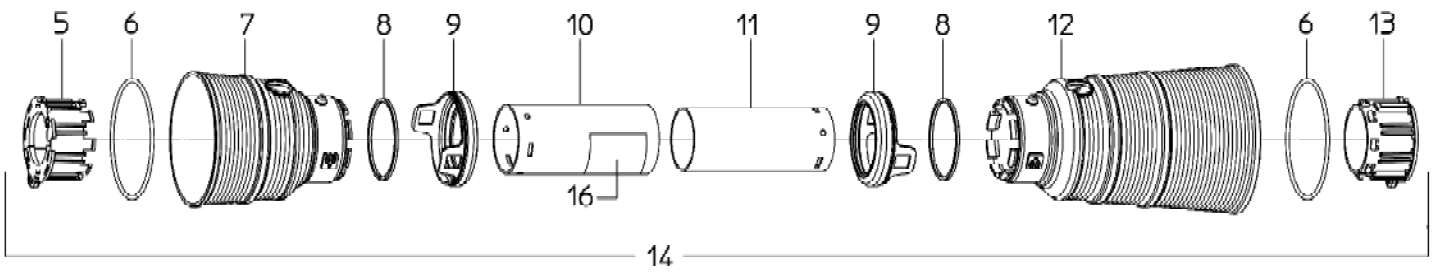
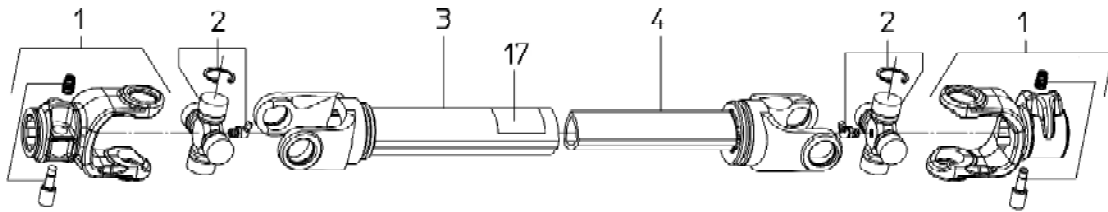

Ref.	Part #	Description	Qty.
1	5BP1023010C	PTO yoke	2
2	5BP1003020C	Cross and bearing	2
3	5BP1943055NC	Outer tube GM2060	1
	5BP1943070NC	Outer tube GM2072, GM2084	1
4	5BP1953057NC	Inner tube GM2060	1
	5BP1953072NC	Inner tube GM2072, GM2084	1
5	5BP1784710C	Outer tube bearing; #XF...277831 & above	1
6	5BP1211733C	Stiffening ring; #XF...277831 & above	2
7	5BP1781703C	Standard cone (tractor end); #XF...277831 & above	1
8	5BP1211735C	Safety ring; #XF...277831 & above	2
9	5BP1881709C	Safety sleeve; #XF...277831 & above	2
10	5BP1773053C	Female tube shield GM2060	1
	5BP1773068C	Female tube shield GM2072, GM2084	1
11	5BP1872053C	Male tube shield GM2060	1
	5BP1872068C	Male tube shield GM2072, GM2084	1
12	5BP1781704C	Long cone (implement end); #XF...277831 & above	1
13	5BP1784711C	Inner tube bearing; #XF...277831 & above	1
14	5BP96SL4053C	Complete shielding GM2060	1
	5BP96SL4068C	Complete shielding GM2072, GM2084	1
15	5BP1006065C	Chain	2
16	5BP950463B	Decal "DANGER - Rotating driveline, keep away" outer shield	1
17	5BP950464B	Decal "DANGER - Guard missing, do not operate" outer tube	1
	5BP0500414	Driveline complete GM2060	-
	5BP0500415	Driveline complete GM2072, GM2084	-

Note: Serial #'s with the XF prefix are subsequent to serial numbers with the BC prefix. For example: A reference to "serial # BC... 739197 & above" will also include all serial numbers with an XF prefix.

Use only original spare parts

All rights reserved. It is unlawful to copy, reprint or use any of the information or details in this manual without the expressed written permission of the Company. Technical information provided in this manual is approximate, the Company reserves the right to modify or improve the models shown for technical or commercial purposes. Pictures in this manual do not necessarily show the machine as delivered.



Manual 5BP960384B
Date 06/01/2009

Free Manuals Download Website

<http://myh66.com>

<http://usermanuals.us>

<http://www.somanuals.com>

<http://www.4manuals.cc>

<http://www.manual-lib.com>

<http://www.404manual.com>

<http://www.luxmanual.com>

<http://aubethermostatmanual.com>

Golf course search by state

<http://golfingnear.com>

Email search by domain

<http://emailbydomain.com>

Auto manuals search

<http://auto.somanuals.com>

TV manuals search

<http://tv.somanuals.com>