

# OPERATOR'S MANUAL

## FERTILIZER SPREADERS

**SS1023B**

**SS1036B**

**SS1067B**

**SS2036B**

**SS2067B**

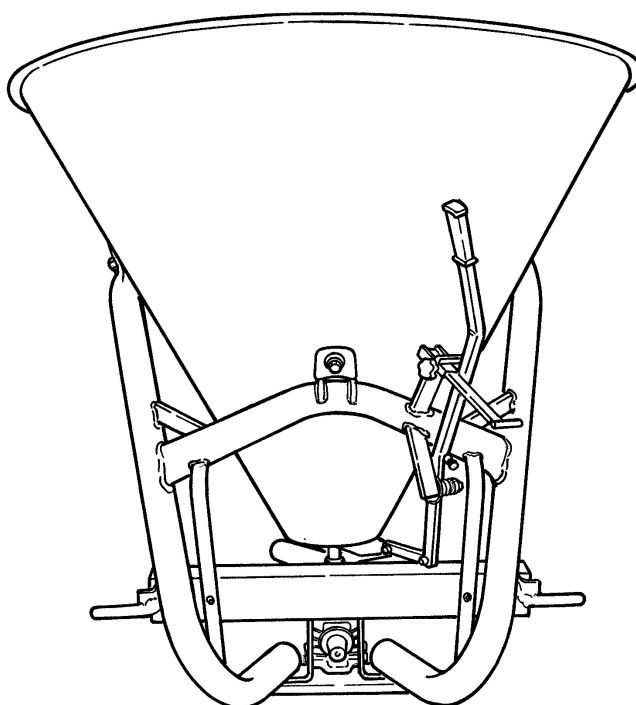

**FRONTIER**  
EQUIPMENT

Manual 5BP960376B  
Date 05/19/2011

# SAFETY

Take note! This safety alert symbol found throughout this manual is used to call your attention to instructions involving your personal safety and the safety of others. Failure to follow these instructions can result in injury or death.



*This symbol means:  
ATTENTION!  
BECOME ALERT!  
YOUR SAFETY IS INVOLVED!*

## Signal Words

Note the use of the signal words DANGER, WARNING and CAUTION with the safety messages. The appropriate signal words for each have been selected using the following guidelines:



**DANGER:** Indicates an imminently hazardous situation that, if not avoided, will result in death or serious injury.



**WARNING:** Indicates a potentially hazardous situation that, if not avoided, could result in death or serious injury, and includes hazards that are exposed when guards are removed. It may also be used to alert against unsafe practices.



**CAUTION:** Indicates a potentially hazardous situation that, if not avoided, may result in minor or moderate injury.

# INDEX

<b>1 - GENERAL INFORMATION</b>	4
1.01 - General	4
1.02 - Model and Serial Number ID	4
1.03 - Assembly Instructions for Model SS1023B	5
1.04 - Assembly Instructions for Models SS1036B & SS2036B	6
1.05 - Assembly Instructions for Models SS1067B & SS2067B	8
<b>2 - SAFETY PRECAUTIONS</b>	11
2.01 - Preparation	11
2.02 - Starting and Stopping	11
2.03 - Messages and Signs	12
<b>3 - OPERATION</b>	14
3.01 - Operational Safety	14
3.02 - Set Up	15
3.03 - Pre-Operational Check	15
3.04 - Attaching to the Tractor	16
3.05 - Start Up	17
3.06 - Operating Techniques	17
3.07 - Uneven Terrain	20
<b>4 - MAINTENANCE</b>	21
4.01 - Maintenance Safety	21
4.02 - Service	22
4.03 - Driveline	22
4.04 - Transport	23
<b>5 - REPAIR PROCEDURES</b>	26
5.01 - Suggested Spare Parts	26
5.02 - Storage	26
<b>6 - TROUBLESHOOTING</b>	27
<b>7 - PRE-DELIVERY CHECKLIST</b>	28
<b>PARTS MANUAL</b>	31

# 1 - GENERAL INFORMATION

Thank you and congratulations for having chosen our implement. Your new fertilizer spreader is a technologically advanced machine constructed of high quality sturdy components that will fulfill your working expectations. Read this manual carefully. It will instruct you on how to operate and service your fertilizer spreader safely and correctly. Failure to do so could result in personal injury and/or equipment damage.

## 1.01 - General

The implement described in this manual is to be used with tractors with PTO at 540 rpm and clockwise rotation.



**CAUTION:** Always ensure that the coupling of the implement with the tractor is done at the same PTO speed and direction of rotation. Do not operate this implement at a PTO speed or direction of rotation other than that shown on the implement. Serious damage can occur to the machine and/or the operator.



**CAUTION:** Unless otherwise specified, all hardware is metric. Use only metric tools on metric hardware. Other tools that do not fit properly can slip and cause injury.



**CAUTION:** Right hand and left hand sides of the implement are determined by facing in the direction the implement will travel when going forward (see fig. 6).

Warranty coverage is provided by John Deere according to the terms of the Agricultural/Commercial & Consumer Equipment Warranty Statement. Carefully read the warranty statement on the back of your original purchase order for details on coverage and limitations of this warranty.

Your Authorized Company Dealer has genuine parts in stock. Only these approved replacement parts should be used.

## 1.02 - Model and Serial Number ID

Attached to the hopper is an ID plate showing the model and the serial number. Record your implement model and serial number in the space provided below. Your dealer needs this information to give you prompt, efficient service when you order parts.



## 1.03 - Assembly Instructions for Model SS1023B



**CAUTION:** Stand clear of bands when cutting as they could be under sufficient tension to cause them to fly loose. Take care in removing bands and wire. They often have extremely sharp edges and cut very easily.

**NOTE:** Assembly will be easier if all parts are loosely assembled before tightening the hardware. All hardware needed for assembly will be found in the hardware bag or on the machine.

Each unit is shipped with a hardware bag that consists of the following:	
Description	Model SS1023B Qty.
Spreader disc (#11, fig. 2)	1
Mobile shutter (#10, fig. 2)	1
Stirrer (#8, fig. 2)	1
Guard (#4, fig. 2)	1
Flow control assembly (#5, fig. 2)	1
Driveline	1
<b>Hardware bag contains the following:</b>	
Bushing cat.0/1 for tractor arms (5BP0014710); serial #XF...287132 & below only	2
Threaded bushing (5BP501622B)	1
Bolt CR M08-1.25x25 C4.6 Z (5BP501663B)	3
Bolt HH M08-1.25x16 C8.8 Z F (5BP0046454)	2
Nut HH M30-2.00 C6 Z TN (5BP501651B)	1
Nut HH M08-1.25 C6 Z TK (5BP0001806)	8
Washer flat Ø8 (5BP0015230)	4
Washer fender Ø8 (5BP0014514)	3
Hairpin cotter Ø5 (5BP0041291)	1

To assemble the spreader do the following:

1. Attach spreader disc (**see #11, fig. 2**) to output shaft of gearbox securing it with the hairpin cotter (**see #27, fig. 2**).
2. Install guard (**see #4, fig. 2**) with scale label facing up to the brackets on the spreader frame. Attach it to the frame using two M8x16 bolts (**see #22, fig. 2**), four Ø8 flat washers (**see #19, fig. 2**) and two M8 nuts (**see #21, fig. 2**).
3. Insert threaded bushing (**see #9, fig. 2**) through hopper bottom (**see #3, fig. 2**). Attach mobile shutter (**see #10, fig. 2**) to threaded bushing and secure with nut (**see #26, fig. 2**).
4. Slide hopper and onto the output shaft of the gearbox. Secure hopper to frame using three M8x25 carriage bolts (**see #18, fig. 2**), three Ø8 fender washers (**see #20, fig. 2**), and six M8 hex nuts (**see #21, fig. 2**).
5. Install flow control assembly (**see #5, fig. 2**) into slot in mobile shutter at the bottom of the hopper.
6. Secure location of the shutter lever by tightening the two knobs (**see #6, fig. 2**).
7. Install the stirrer (**see #8, fig. 2**) using M8x35 hex bolt (**see #24, fig. 2**), two Ø8 flat washers (**see #19, fig. 2**), and one M8 elastic stop nut (**see #25, fig. 2**) that are already bolted to the stirrer.
8. Tighten all hardware.
9. Install driveline and ensure it has at least 2" from bottoming out in its shortest working position and has the minimum 6" overlap in its longest working position. Refer to **Section 4.03<sup>1</sup>** of this manual, if it is determined that the driveline is too long and needs to be shortened. Contact your local dealer if it is determined that the driveline is too short for your tractor.

<sup>1</sup> See Section 4.03 - Driveline, for instructions on how to determine correct driveline length and procedures for shortening the driveline.

Fig. 2 - Model SS1023 assembly.

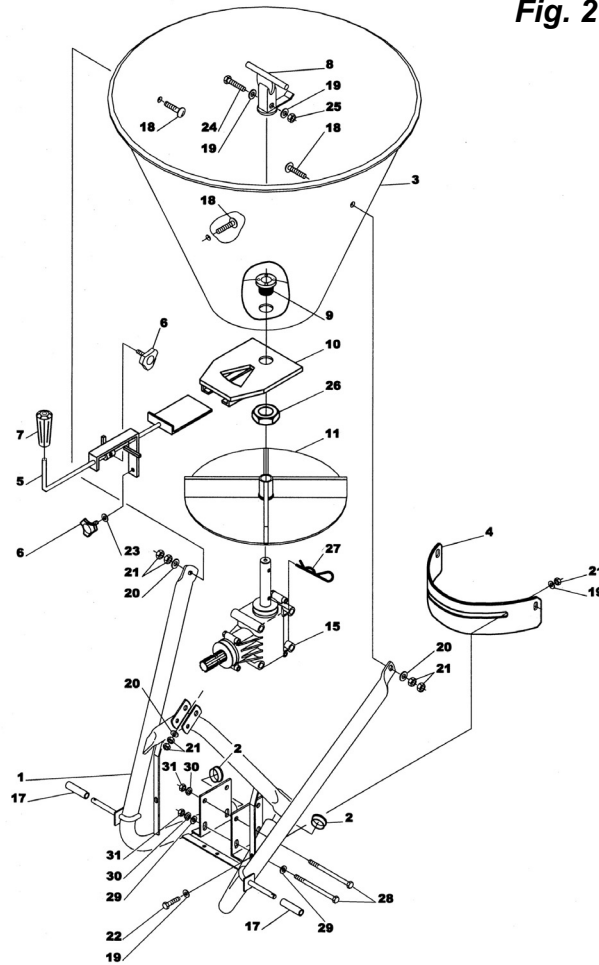

### 1.04 - Assembly Instructions for Models SS1036B & SS2036B

Each unit is shipped with a hardware bag that consists of the following:

Description	Model SS1036B Qty.	Model SS2036B Qty.
Spreader disc (#21, fig. 3)	1	1
Shutter assembly	1	1
Protection (#5, fig. 3)	1	1
Lever (#16, fig. 3)	1	1
Scaled rod assembly (#18, fig. 3)	1	1
Stationary stirrer (#20, fig. 3)	1	1
Protection (#4, fig. 3)	1	1
Driveline	1	1
<b>Hardware bag contains the following:</b>		
Attachment plate (5BP0014338) (#6, fig. 3)	1	-
Attachment plate (5BP0014635) (#6, fig. 3)	-	1
Bushing cat.0/1 for tractor arms (5BP0014710)	2	2
Bolt CR M08-1.25x20 C4.6 Z (5BP0084289)	3	2
Bolt CR M08-1.25x25 C4.6 Z (5BP501663B)	3	-
Bolt CR M08-1.25x35 C4.6 Z (5BP0014619)	-	3
Bolt HH M08-1.25x16 C8.8 Z F (5BP0046454)	1	1
Bolt HH M08-1.25x20 C8.8 Z F (5BP0015012)	2	2
Nut HH M08-1.25 C6 Z MD (5BP0046545)	6	5
Nut HH M08-1.25 C6 Z TK (5BP0001806)	6	6
Washer lock Ø8 (5BP0003144)	3	2
Washer flat Ø8 (5BP0015230)	7	6
Washer fender Ø8 (5BP0014514)	3	3
Washer fender Ø10 (5BP0030157)	2	2
Hairpin cotter Ø5 (5BP0041291)	1	1



**CAUTION:** Stand clear of bands when cutting as they could be under sufficient tension to cause them to fly loose. Take care in removing bands and wire. They often have extremely sharp edges and cut very easily.

**NOTE:** Assembly will be easier if all parts are loosely assembled before tightening the hardware. All hardware needed for assembly will be found in the hardware bag or on the machine.

**Fig. 3 - Model SS1036B & SS2036B assembly.**

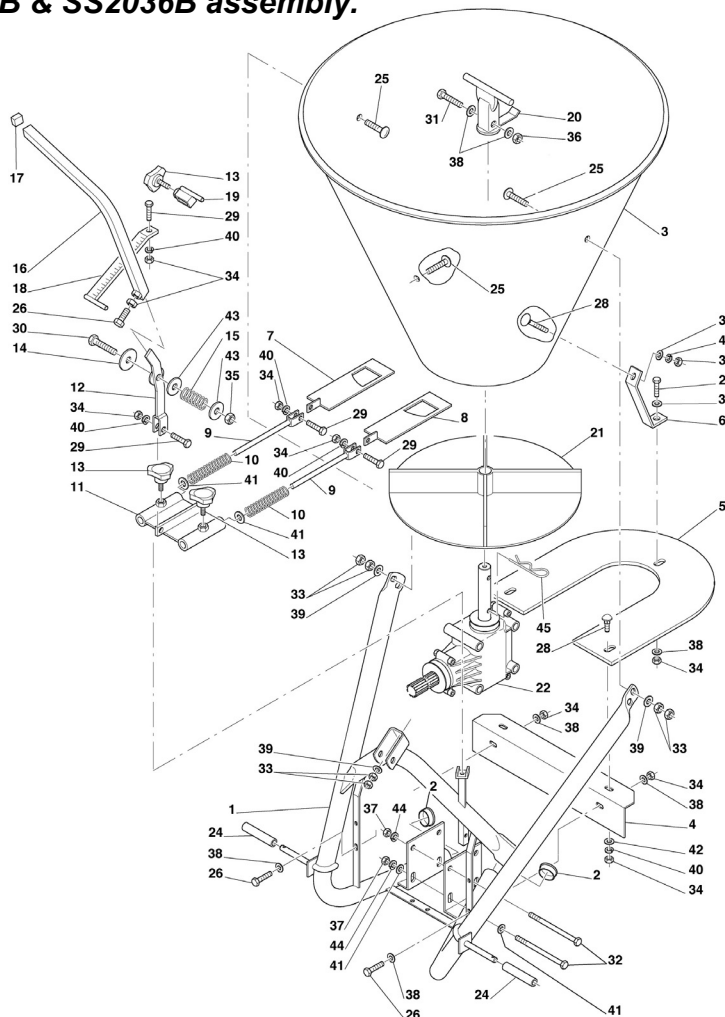

To assemble the spreader do the following:

1. Attach spreader disc (**see #21, fig. 3**) to the output shaft of the gearbox using hairpin cotter (**see #45, fig. 3**).
2. Locate scaled rod assembly (**see #18, fig. 3**) in hardware bag. Install scaled rod to main frame using M8x30 bolt (**see #29, fig. 3**), Ø8 lock washer (**see #40, fig. 3**), M8 hex nut (**see #34, fig. 3**) that are already installed on the scaled rod assembly.
3. Install protection (**see #4, fig. 3**) onto spreader frame using two M8x20 hex bolts (**see #26, fig. 3**), four Ø8 flat washers (**see #38, fig. 3**), and two M8 hex nuts (**see #34, fig. 3**).
4. Slide hopper onto the output shaft of the gearbox. Secure hopper to frame using three M8x25 carriage bolts on model SS1036 or M8x35 on model SS2036 (**see #25, fig. 3**), three Ø8 fender washers (**see #39, fig. 3**), and six M8 hex nuts (**see #33, fig. 3**).

5. Install the stationary stirrer (see #20, fig. 3) using M8x45 hex bolt (see #31, fig. 3), two Ø8 flat washers (see #38, fig. 3), and one M8 elastic stop nut (see #36, fig. 3) that are already bolted to the stirrer.
6. Install protection (see #5, fig. 3) using two M8x20 carriage bolts (see #28, fig. 3), two Ø10 fender washers (see #42, fig. 3), two Ø8 lock washers (see #40, fig. 3) and secure with two M8 hex nuts (see #34, fig. 3). Install attachment plate (see #6, fig. 3) on protection using M8x16 hex bolt (see #27, fig. 3), two Ø8 flat washers (see #38, fig. 3) and secure with M8 hex nut (see #34, fig. 3), then install it to the hopper using M8x20 carriage bolt on model SS1036 or M8x25 on model SS2036 (see #28, fig. 3), on model SS2036 use bolt already installed on hopper, and secure with Ø8 flat washer (see #38, fig. 3), Ø8 lock washer (see #40, fig. 3) and a M8 hex bolt (see #34, fig. 3).
7. Install shutter assembly found in the hardware bag by sliding shutters (see #7 & #8, fig. 3) into the slots at bottom of the hopper.
8. Assemble shutter guide plate (see #11, fig. 3) to lever bracket (see #12, fig. 3), which is already installed on the frame using M8x30 hex bolt (see #29, fig. 3), Ø8 lock washer (see #40, fig. 3), and M8 hex nut (see #34, fig. 3).
9. Install lever (see #16, fig. 3) to lever bracket using one M8x20 hex bolt (see #26, fig. 3) which is shipped installed on the lever. Secure bolt with M8 hex nut (see #34, fig. 3).
10. Tighten all hardware.
11. Install driveline and ensure it has at least 2" from bottoming out in its shortest working position and has the minimum 6" overlap in its longest working position. Refer to Section 4.03<sup>2</sup> of this manual, if it is determined that the driveline is too long and needs to be shortened. Contact your local dealer if it is determined that the driveline is too short for your tractor.

## 1.05 - Assembly Instructions for Models SS1067B & SS2067B

Each unit is shipped with a hardware bag that consists of the following:		
Description	Model SS1067B Qty.	Model SS2067B Qty.
Lever (#14, fig. 4)	1	1
Hitch lever (#15, fig. 4)	1	1
Scaled rod (#17, fig. 4)	1	1
Shutter assembly (#9, fig. 4)	1	1
Protection (#4, fig. 4)	1	1
Protection (#1, fig. 5)	1	1
Spreader wings (#20, fig. 4)	4	4
Stationary stirrer (#21, fig. 4)	1	1
Driveline	1	1
<b>Hardware bag contains the following:</b>		
Attachment plate (5BP0014338) (#2, fig. 5)	1	-
Attachment plate (5BP0014339) (#2, fig. 5)	-	1
Bolt CR M12-1.75x30 C4.6 Z (5BP0051073)	3	-
Bolt CR M12-1.75x40 C8.8 Z (5BP0044115)	-	3
Bolt CR M08-1.25x20 C4.6 Z (5BP0084289)	1	-
Bolt HH M08-1.25x16 C8.8 Z F (5BP0046454)	3	3
Bolt HH M08-1.25x20 C8.8 Z F (5BP0015012)	2	2
Bolt HH M06-1.00x16 C8.8 Z F (5BP0036319)	8	8
Nut HH M12-1.75 C6 Z MD (5BP0001106)	6	6
Nut HH M08-1.25 C6 Z MD (5BP0046545)	6	5
Nut HH M06-1.00 C6 Z TK (5BP501603B)	8	8
Washer lock Ø6 (5BP0046536)	8	8
Washer lock Ø8 (5BP0003144)	1	-
Washer flat Ø8 (5BP0015230)	11	10
Washer flat Ø14 (5BP0091435)	3	3

<sup>2</sup> See Section 4.03 - Driveline, for instructions on how to determine correct driveline length and procedures for shortening the driveline.





**CAUTION:** Stand clear of bands when cutting as they could be under sufficient tension to cause them to fly loose. Take care in removing bands and wire. They often have extremely sharp edges and cut very easily.

**NOTE:** Assembly will be easier if all parts are loosely assembled before tightening the hardware. All hardware needed for assembly will be found in the hardware bag or on the machine.

**Fig. 4 - Models SS1067B & SS2067B assembly.**

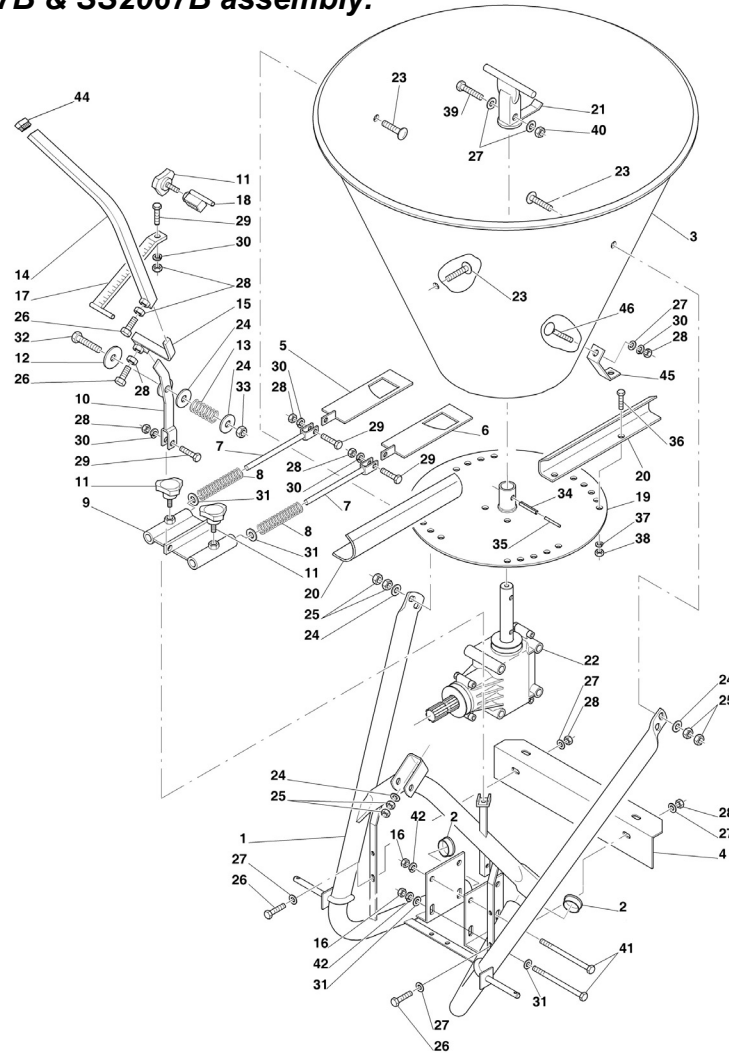

To assemble the spreader do the following:

1. Attach four spreader wings (see #20, fig. 4) to the spreader disc (see #19, fig. 4) with eight M6x16 hex bolts (see #36, fig. 4), Ø6 lock washers (see #37, fig. 4) and M6 hex nuts (see #38, fig. 4).
2. Locate scaled rod assembly (see #17, fig. 4) in hardware bag. Install scaled rod to main frame using M8x30 hex bolt (see #29, fig. 4), Ø8 lock washer (see #30, fig. 4) and M8 hex nut (see #28, fig. 4) that are already installed on the scaled rod assembly.
3. Install protection (see #4, fig. 4) on spreader frame using two M8x20 hex bolts (see #26, fig. 4), two Ø8 flat washers (see #27, fig. 4) and two M8 hex nuts (see #28, fig. 4).
4. Slide hopper (see #3, fig. 4) onto the output shaft of the gearbox.

5. Secure hopper to frame using three M12x30 carriage bolts on model SS1067B or M12x40 on model SS2067B (see #23, fig. 4), three Ø14 flat washers (see #24, fig. 4), and six M12 hex nuts (see #25 fig. 4).
6. Install stationary stirrer (see #21, fig. 4) using M8x45 bolt (see #39, fig. 4), two Ø8 flat washers (see #27, fig. 4), and M8 elastic stop nut (see #40, fig. 4) that are already bolted to the stirrer.
7. **This step only applies to units with serial #BC...304870 and above.** Install spreader disc shield (see #1, fig. 5) using three M8x16 hex bolts (see #3, fig. 5), six Ø8 flat washers (see #4, fig. 5), one Ø8 lock washer (see #5, fig. 5), and three M8 hex nuts (see #6, fig. 5). Install M8x20 carriage bolt (see #7, fig. 5) on SS1067B or M8x25 on SS2067B through hopper and into attachment plate (see #2, fig. 5). On model SS2067B use bolt already installed on hopper.
8. Install shutter assembly, found in hardware bag, by sliding shutters (see #5 & #6, fig. 4) into the slots at the bottom of the hopper.
9. Assemble shutter guide plate (see #9, fig. 4) to lever bracket (see #10, fig. 4), which is already installed on the frame, using M8x30 hex bolt (see #29, fig. 4), Ø8 lock washer (see #30, fig. 4), and M8 hex nut (see #28, fig. 4).
10. **This step only applies to units with serial #BC...304870 and above.** Attach hitch lever (see #15, fig. 4) to lever bracket (see #10, fig. 4) by loosening M8x20 hex bolt (see #26, fig. 4) which is shipped already installed onto hitch lever. Secure bolt with M8 hex nut (see #28, fig. 4).
11. Install lever (see #14, fig. 4) to hitch lever using M8x20 hex bolt (see #26, fig. 4) and M8 hex nut (see #28, fig. 4) which is shipped already installed on the lever.
12. Tighten all hardware.
13. Install driveline and ensure it has at least 2" from bottoming out in its shortest working position and has the minimum 6" overlap in its longest working position. Refer to **Section 4.03<sup>3</sup>** of this manual, if it is determined that the driveline is too long and needs to be shortened. Contact your local dealer if it is determined that the driveline is too short for your tractor.

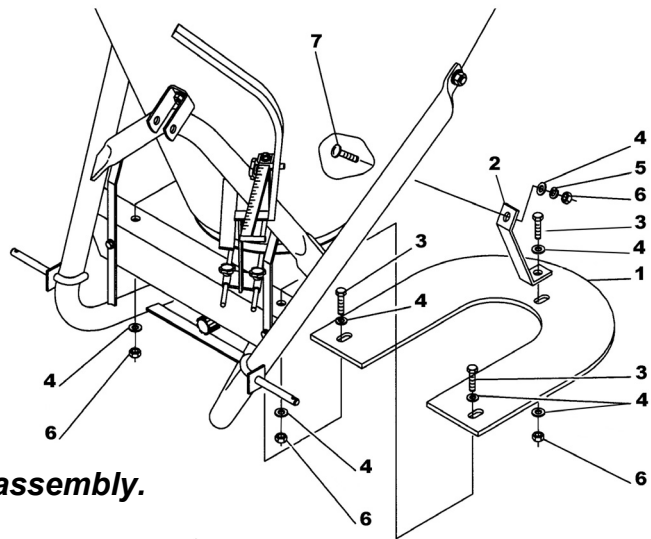

**Fig. 5 - Models SS1067B & SS2067B shield assembly.**  
(serial #BC...304870 and above)

<sup>3</sup> See Section 4.03 - Driveline, for instructions on how to determine correct driveline length and procedures for shortening the driveline.

## 2 - SAFETY PRECAUTIONS

Safety is the primary concern in the design and manufacture of our products. Unfortunately our efforts to provide safe equipment can be wiped out by a single careless act of an operator.

In addition to the design and configuration of equipment, hazard control and accident prevention are dependent upon the awareness, concern, prudence and proper training of personnel involved in the operation, transport, maintenance and storage of equipment.

It is the operator's responsibility to read and understand all safety and operating instructions in the manual and to follow these.

Allow only properly trained personnel to operate the fertilizer spreader. Working with unfamiliar equipment can lead to careless injuries. Read this manual, and the manual for your tractor, before assembly or operation, to acquaint yourself with the machines. It is the spreader owner's responsibility, if this machine is used by any person other than yourself, is loaned or rented, to make certain that the operator, prior to operating, reads and understands the operator's manuals and is instructed in safe and proper use.

### 2.01 - Preparation



1. Before operating equipment read and understand the operator's manual and the safety signs (**see fig. 6**).
2. Thoroughly inspect the implement before initial operation to assure that all packaging materials, i.e., wires, bands, and tape have been removed.
3. Personal protection equipment including hard hat, safety glasses, safety shoes, and gloves are recommended during assembly, installation, operation, adjustment, maintaining and/or repairing the implement.
4. Operate the fertilizer spreader only with a tractor equipped with an approved Roll-Over-Protective-System (ROPS). Always wear your seat belt. Serious injury or even death could result from falling off the tractor.
5. Clear area of stones, branches or other debris that might be thrown, causing injury or damage.
6. Operate only in daylight or good artificial light.
7. Ensure fertilizer spreader is properly mounted, adjusted and in good operating condition.
8. Ensure that all safety shielding and safety signs are properly installed and in good condition.
9. Chemicals may cause eye, skin or breathing problems. Always wear a face mask, gloves and goggles when filling hopper.
10. Before loading the fertilizer in the hopper read carefully the instructions printed on the fertilizer canvas bag concerning the precautions to be taken in case of toxicity or corrosivity of the product. Before loading switch off the engine and remove the ignition key.
11. Load hopper with product only after the spreader has been properly attached to the tractor.

### 2.02 - Starting and Stopping



1. Be sure that no one is near the machine prior to engaging or while the machine is working.
2. Be sure the tractor is in "Neutral" before starting engine.

3. The operating power is supplied from tractor PTO. Refer to your tractor manual for PTO engagement and disengagement instructions. Always operate PTO at 540 rpm. Know how to stop the tractor and machine quickly in case of an emergency.
4. When engaging PTO, the engine rpm should always be low. Once engaged and ready to start operating, raise PTO speed to 540 rpm and maintain throughout operation.
5. Check the tractor master shield over the PTO stub shaft. Make sure it is in good condition and fastened securely to the tractor. Purchase a new shield if old shield is damaged or missing.
6. After striking an obstacle, disengage the PTO, shut the tractor down and thoroughly inspect for damage before restarting.
7. To park the vehicle safely, stop vehicle on a level surface (not on a slope), disengage PTO, engage the parking brake, stop the engine, remove the key, and wait for engine and all moving parts to stop before leaving the operator's seat.
8. Stay clear of rotating drivelines. Entanglement in rotating driveline can cause serious injury or death. Wear close fitting clothing. Stop the engine and be sure PTO driveline is stopped before getting near it.

## 2.03 - Messages and Signs



1. Read and adhere to all safety and operating decals on this machine (see fig. 6).
2. Before dismounting tractor: Stop engine, set brake and remove the key of unattended equipment.
3. Keep away from rotating parts and driveline.
4. Keep guards and shields in place and in good condition.
5. Do not use with bystanders in area.
6. Allow no riders on tractor or fertilizer spreader.
7. Allow moving parts to stop before repair.
8. Securely support fertilizer spreader before working underneath.

Additional warning and operating decals are available at no extra charge. Please specify model and serial number when ordering.

**Fig. 6 - Safety decals - driveline; replace immediately if damaged.**

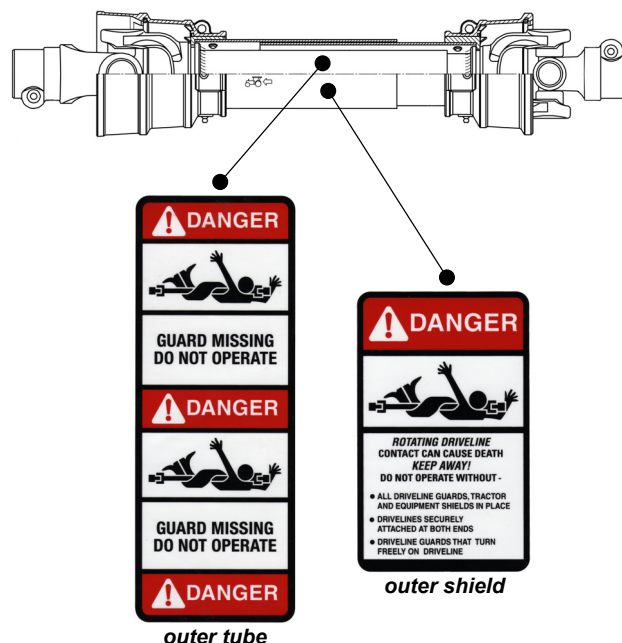

**Safety decals - implement; replace immediately if damaged.**

	<p>⚠ <b>DANGER</b></p>
<p><b>Avoid injury from PTO</b></p> <ul style="list-style-type: none"> <li>• Entanglement can cause serious injury or death.</li> <li>• Keep driveline shields in place &amp; in good condition.</li> <li>• Keep hands, feet and clothing away.</li> <li>• Operate only with 540 RPM.</li> </ul> <p style="text-align: right; font-size: small;">950-1098</p>	



	<p>⚠ <b>WARNING</b></p>
<p style="text-align: center;"><b>Toxic chemical hazard</b></p> <ul style="list-style-type: none"> <li>• Chemicals may cause eye, skin or breathing problems.</li> <li>• To prevent serious injury or death:                     <ul style="list-style-type: none"> <li>• Wear face mask, gloves, and goggles.</li> <li>• Read and follow safety instructions of the chemical supplier's label.</li> </ul> </li> </ul> <p style="text-align: center;"><b>Failure to follow these instructions can cause serious injury or death.</b></p> <p style="text-align: right; font-size: small;">950-3388</p>	

right side

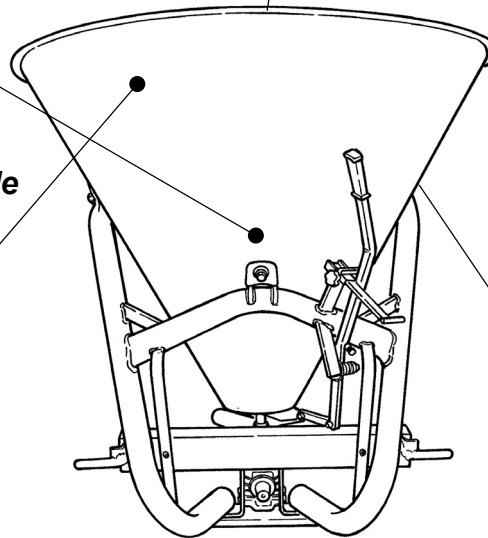
left side

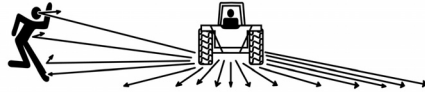

<p>⚠ <b>CAUTION</b></p>
<p style="text-align: center;"><b>To avoid serious injury:</b></p> <ul style="list-style-type: none"> <li>• Read Operator's Manual before operating, servicing or repairing equipment. Follow all safety rules and instructions. (Manuals are available from your selling dealer.)</li> <li>• Never allow riders.</li> <li>• Keep bystanders away from equipment during operation.</li> <li>• Operate from tractor seat only.</li> <li>• Keep all shields in place and in good condition.</li> <li>• Lower equipment to ground, stop engine, remove key and set brake before dismantling tractor.</li> <li>• Never allow children or untrained persons to operate equipment.</li> <li>• If equipped, parking stands must be functional, kept in good repair, and stored on the unit. Park and store on a hard, level surface.</li> </ul> <p style="text-align: right; font-size: small;">950-417B</p>

<p>⚠ <b>WARNING</b></p>	
	
<p style="text-align: center;"><b>Thrown objects/moving parts hazard</b></p> <ul style="list-style-type: none"> <li>• Keep others away.</li> <li>• Keep away from discharge area during operation.</li> <li>• Do not point discharge towards animals, people, or buildings when operating.</li> <li>• Keep hands, feet, hair, and clothing away from moving parts.</li> <li>• Disconnect, lockout power source and wait for all movement to stop before adjusting or servicing.</li> </ul> <p style="text-align: center;"><b>Failure to follow these instructions could result in serious injury or death.</b></p> <p style="text-align: right; font-size: small;">950-3388</p>	

## 3 - OPERATION

The fertilizer spreader is versatile and ideal for granular or powdered fertilizers, seed and sand. It may also be used as a salt spreader for snow or ice covered roads during winter months. Our spreaders are designed for tractors from 16 to 30 PTO HP with a category 1 three point hitch.

Spreaders can be used for broadcast spreading or may be used to spread prevalently to the left or to the right with a simple adjustment.

The wide range of hopper capacities and numerous spread adjustments make our fertilizer spreaders ideal for use on farms, athletic fields, municipalities and many other commercial or residential applications.

### 3.01 - Operational Safety



**CAUTION:** Our spreaders are designed considering safety as the most important target and are the safest available in today's market. Unfortunately, human carelessness can override the safety features built into our machines. Injury prevention and work safety, aside from the features on our spreaders, are very much due to the responsible use of the equipment. It must always be operated prudently following with great care, the safety instructions laid out in this manual.



1. The use of this equipment is subject to certain hazards which cannot be prevented by mechanical means or product design. All operators of this equipment must read and understand this entire manual, paying particular attention to safety and operating instructions, prior to using.
2. Do not operate the tractor and spreader when you are tired, sick or when using medication.
3. This spreader is designed for use only on tractors with 540 rpm power take off.
4. Only properly trained people should operate this machine.
5. Accidents are most likely to occur with machines that are loaned or rented to someone who has not read the operator's manual and is not familiar with a spreader.
6. Always stop the tractor, set brake, shut off the tractor engine, remove the ignition key, and allow spreader moving parts to come to a complete stop before dismounting tractor. Never leave equipment unattended with the tractor running.
7. Never place hands or feet into hopper with tractor engine running or before you are sure all motion has stopped. Stay clear of all moving parts.
8. Never allow any person inside the hopper for any reason. Serious injury or death can result from someone becoming entangled in the agitator.
9. Do not allow riders on the spreader or tractor at any time. There is no safe place for riders.
10. Never allow anyone within 50 yards of the spreader while the PTO is engaged. Product thrown from the spreader can cause serious injury or death.
11. Before backing up, look behind carefully.
12. Install and secure all guards and shields before starting or operating.
13. Keep hands, feet, hair and clothing away from moving parts.
14. Never operate tractor and spreader under trees with low hanging limbs. Operators can be knocked off the tractor and then run over.
15. Stop spreader immediately upon striking an obstruction. Turn engine off, remove key, inspect and repair any damage before resuming operation.

16. Stay alert for holes, rocks and roots in the terrain and other hidden hazards. Keep away from drop-offs.
17. Use extreme care and maintain minimum ground speed when transporting on hillside, over rough ground and when operating close to ditches or fences. Be careful when turning sharp corners.
18. Reduce speed on slopes and sharp turns to minimize tipping or loss of control. Be careful when changing directions on slopes. Do not start or stop suddenly on slopes. Avoid operation on steep slopes.
19. Inspect the entire machine periodically<sup>4</sup>. Look for loose fasteners, worn or broken parts, and leaky or loose fittings.
20. Pass diagonally through sharp dips and avoid sharp drops to prevent "hanging up" tractor and spreader.
21. Avoid sudden starts and stops while traveling up or downhill.
22. Always operate down slopes; never across the face. Avoid operation on steep slopes. Slow down on sharp turns and slopes to prevent tipping and/or loss of control.
23. All remote control devices (cables, ropes, rods, flexible lines, etc.) should be positioned in a way to prevent maneuvers which could lead to accidents or damages.
24. Chemicals may cause eye, skin or breathing problems. Always wear a face mask, gloves and goggles when filling hopper.
25. Before loading the fertilizer in the hopper read carefully the instructions printed on the fertilizer canvas bag concerning the precautions to be taken in case of toxicity or corrosivity of the product. Before loading switch off the engine and remove the ignition key.
26. Load hopper with product only after the spreader has been properly attached to the tractor.

### 3.02 - Set Up

**Notice to dealer:** Pre-Delivery set up and service including lubrication are the responsibility of the authorized dealer. It is up to him to assure that the machine is in perfect condition and ready to be used. It is his responsibility to ensure that the customer is aware of all safety aspects and operational procedures for the spreader. He must also fill out the Pre-Delivery Checklist<sup>5</sup> prior to delivering the spreader.



**CAUTION:** Stand clear of bands when cutting as they could be under sufficient tension to cause them to fly loose. Take care in removing bands and wire, as they often have extremely sharp edges and cut very easy.

### 3.03 - Pre-Operational Check

Check each of the following, carefully, prior to engaging the equipment:

1. No wrappings or foreign objects are around the spreader.
2. All hardware is tight.
3. All safety shields and guards are in place and tightly attached.
4. No people or animals are in the work area.



**DANGER:** Shut off the tractor and remove the key before making adjustments, servicing or cleaning the machine.

<sup>4</sup> See Chapter 4 - Maintenance.

<sup>5</sup> See Chapter 7 - Pre-Delivery Checklist.

### 3.04 - Attaching to the Tractor

Unit may be used on tractors ranging from 16 to 30 HP equipped with a standard rear PTO and category 1 three point hitch<sup>6</sup>. **Never use this spreader with tractors over 30 HP.**



**DANGER:** Do not allow anyone to stand between spreader and tractor while attaching implement.



**WARNING:** Never attempt to attach the implement to the tractor or make an adjustment to it without first turning the tractor off.



**CAUTION:** Check the tractor PTO rpm to ensure it is set at 540 rpm and turns clockwise.



**CAUTION:** Be sure the tractor tire pressure is correct. It is important to strictly follow the safety guidelines and instructions laid out in the tractor manual.

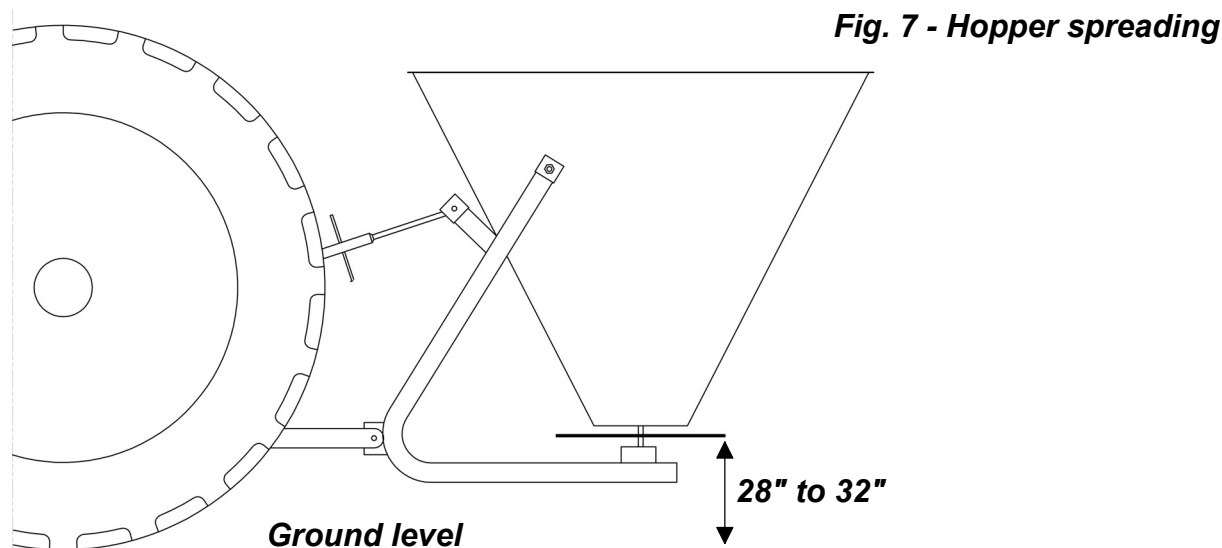

*Fig. 7 - Hopper spreading adjustment.*

To attach the implement to the tractor do the following:

Back the tractor up to the implement in order to slip the tractor hitch arms over the hitch pins bolted to the frame. **Turn off the tractor engine and engage the park brake.** Secure the two tractor hitch arms to the implement with lynch pins. Tighten the tractor arms side movement with either the sway chains or blocks to limit side swing.

Connect the top link, locking it in place with the top hitch pin. Adjust it so the implement is as near parallel to the ground as possible with the spreading disc at a distance 28" to 32" above ground level (see fig. 7).

Install the end of the driveline to the spreader and the opposite end to the tractor PTO. Be sure each end is connected securely with either the locking pin or bolt and nut. Connect the driveline shielding chains to the tractor and to the implement to prevent the protective shielding from rotating during

<sup>6</sup> See Table 2, page 24.



operation. If it was necessary to remove the PTO shielding to do any of the above operations, do not forget to replace it.

### 3.05 - Start Up



**CAUTION:** Load hopper with product only after the spreader has been properly attached to the tractor.



**WARNING:** Chemicals may cause eye, skin or breathing problems. Always wear a face mask, gloves and goggles when filling hopper. Refer to chemical manufacturer's label for specific safety information.

Before starting to use, never forget that the **operator is responsible** for the following:

1. Safe and correct driving of the tractor and spreader.
2. To learn precise, safe operating procedures for both the tractor and the spreader.
3. To ensure all maintenance and lubrication has been performed on the spreader.
4. To have read and understood all safety aspects for the spreader in the operator's manual.
5. To have read and understood all safety decals on the spreader.
6. Checking the tractor tires for the proper pressure in accordance with the tractor operator's manual.
7. **Checking that all safety shields are on the machine and securely in place.**
8. Making sure the proper attire is worn. Avoiding loose fitting clothing which can become entangled. Wearing sturdy, tough-soled work shoes and protective equipment for eyes, hands, ears and head. Never operate tractor or implements in bare feet, sandals or sneakers.
9. Ensuring proper lighting is available, sunlight or good artificial lighting.



**WARNING:** Use a tractor with a cab and appropriate filters on the ventilation system or wear a breathing mask capable of filtering toxic powders to prevent inhalation of product.

Prior to start working do the following:

1. Make sure there are no obstructions.
2. Run machine under a no-load condition for a short while to assure that everything is functioning properly.
3. Adjust all settings for the desired quantity distribution and spread pattern.
4. Shift the transmission to a slow speed gear and start forward, increase the ground speed by shifting upward until the desired speed is obtained. Do not use in reverse unless absolutely necessary and only after careful observation of the area behind the spreader.
5. Ballast may need to be added to tractor to maintain steering control.

### 3.06 - Operating Techniques



**WARNING:** Before adjusting the spreader or filling the hopper, be sure the tractor PTO is not engaged, the tractor is shut off, and the key is removed from the tractor ignition.



**WARNING:** Before engaging the PTO, be sure no persons or animals are behind or beside the spreader.



**DANGER:** Never allow anyone within 50 yards of the spreader while the PTO is engaged. Product thrown from the spreader can cause serious injury or death.



**DANGER:** Never allow any person inside the hopper for any reason. Serious injury or death can result from someone becoming entangled in the agitator.

The quantity of material distributed per acre depends on the following factors:

1. Spreader ground speed.
2. Unit weight and size of the material to be spread.
3. Spreading width.
4. Position of the lever connected to the hopper gates.

The working speed depends on ground conditions. Only a test run will enable you to gauge the optimal working speed for your conditions.

#### **Spread adjustment for Model SS1023B:**

The spreading is adjustable in three ways by:

1. Regulating the **spread pattern**.
2. Regulating the **amount of material to be spread**.
3. Regulating the **spreading width**.

To regulate the **spread pattern** slide (to the left or right) the shutter lever (**see #5, fig. 2**) which is located under the hopper and runs through the slot in the mobile shutter (**see #10, fig. 2**). To shift the shutter lever right or left, loosen the knob over the slotted shield. This moves the spread pattern from 180° at position 0 (in the center), to either mostly 90° right with the shutter lever shifted all the way to the left or mostly 90° left when shifted to the right completely (**see fig. 8**).

To regulate the **amount of material to be spread**, using the same shutter lever as above (**see #5, fig. 2**), slide it in and out to regulate the size of opening at the bottom of the hopper. Use the scale located on the shutter lever to gauge the size opening needed. Example: if it is determined that the appropriate opening desired is position #6, loosen the knob so the blocking plate will slide. Push the lever in until the hole is completely closed and move the blocking plate to position #6 and tighten the knob. To spread, pull the lever back until it stops in position #6.

To regulate the **spreading width**, you should use the optional rear deflector. Move the deflector up and down to change the spreading distance. The higher the deflector is up the further the spread width, the lower the less distance the material travels.

To help the operator set the spreader correctly, Table 3<sup>7</sup> gives the amount of material distributed (lbs/acre) at a spreading widths (20 ft.) for each of the ten lever positions. Example: With the shutter lever in position 6, a ground speed of 2.5 mph, spreading at 20 ft., the output should be approximately 553 lbs. per acre.

<sup>7</sup> See Table 3 - Model SS1023B swath spread patterns, page 25.

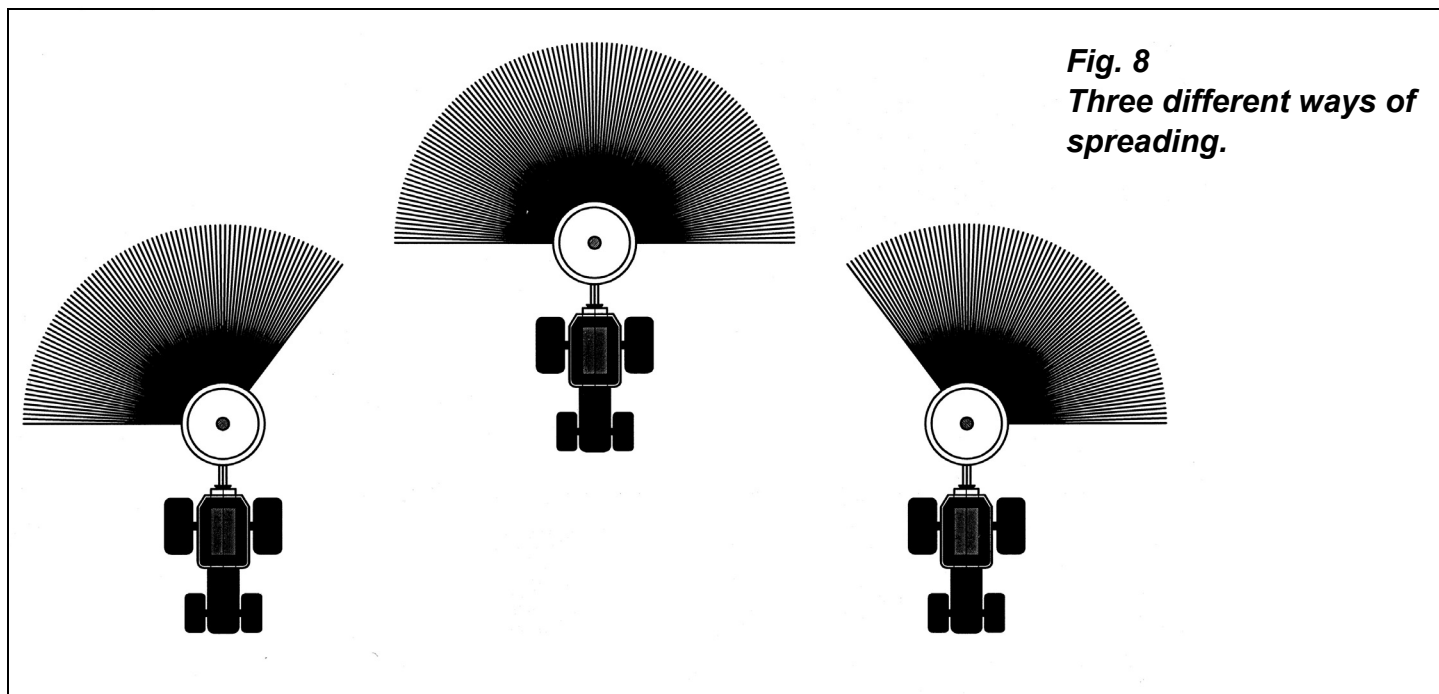

**Fig. 8**  
**Three different ways of spreading.**

### Spread adjustment for Models SS1036B, SS2036B, SS1067B & SS2067B:

These fertilizer spreaders have two ways of regulating material distribution:

1. Adjusting the **spread position**.
2. Adjusting the **quantity of material being spread**.

**Adjusting the spread position:** The machine can be adjusted to spread to the center or off to either of the two sides. This is accomplished by opening the left gate (see #15, fig. 4), right gate (see #5, fig. 4) or both. When spreading center behind the tractor, both gates should be open. To spread more towards the right, operate the spreader with the right gate open and the left gate closed. To spread more to the left, close the right gate and leave the left open. By leaving one of the gates open, the spread tends to be heavier in that direction. The side that the closed gate is on will have some material dispersed to it, though not as heavy as the other side.

To open only one gate:

1. Pull down the lever (see #14, fig. 4) thereby closing both gates, or.
2. Completely loosen the knob (see #11, fig. 4) on the gate to be left closed.

When the lever is pulled open, the gate with the loose knob will remain closed.

One further adjustment possible on Models SS1067B & SS2067B is to adjust the wings (see #20, fig. 4) that are bolted to the spinner disc (see #19, fig. 4). Moving the wings counterclockwise makes the material spread more to the right, whereas moving the wings clockwise will move the spread pattern more towards the left (see fig. 9).

If, for example, the material being spread tends to be thrown center-right and the desired direction is more towards the left, simply move the fins counterclockwise and close the right gate.

**Adjusting the quantity of material being spread:** To adjust the amount of material being spread, move the lever in and out, thereby closing and opening the gates located in the bottom of the hopper. Use the scaled rod (see #17, fig. 4) to regulate the amount of opening desired. Completely close the gates by pushing the lever (see #14, fig. 4) up. Loosen the plastic knob and move it down to the desired number on the scale. Tighten the knob. When the lever is pulled down, it should go down no further than the stop plate on the sliding scale.

Use Table 4<sup>8</sup> to determine the approximate amount of material to be spread in lbs./acre at a 46 foot spreading width and put the lever into that position on the sliding scale.

Example: With the lever in position 5, a ground speed of 5 mph, spreading at 46 ft., the output should be approximately 246 lbs. per acre.

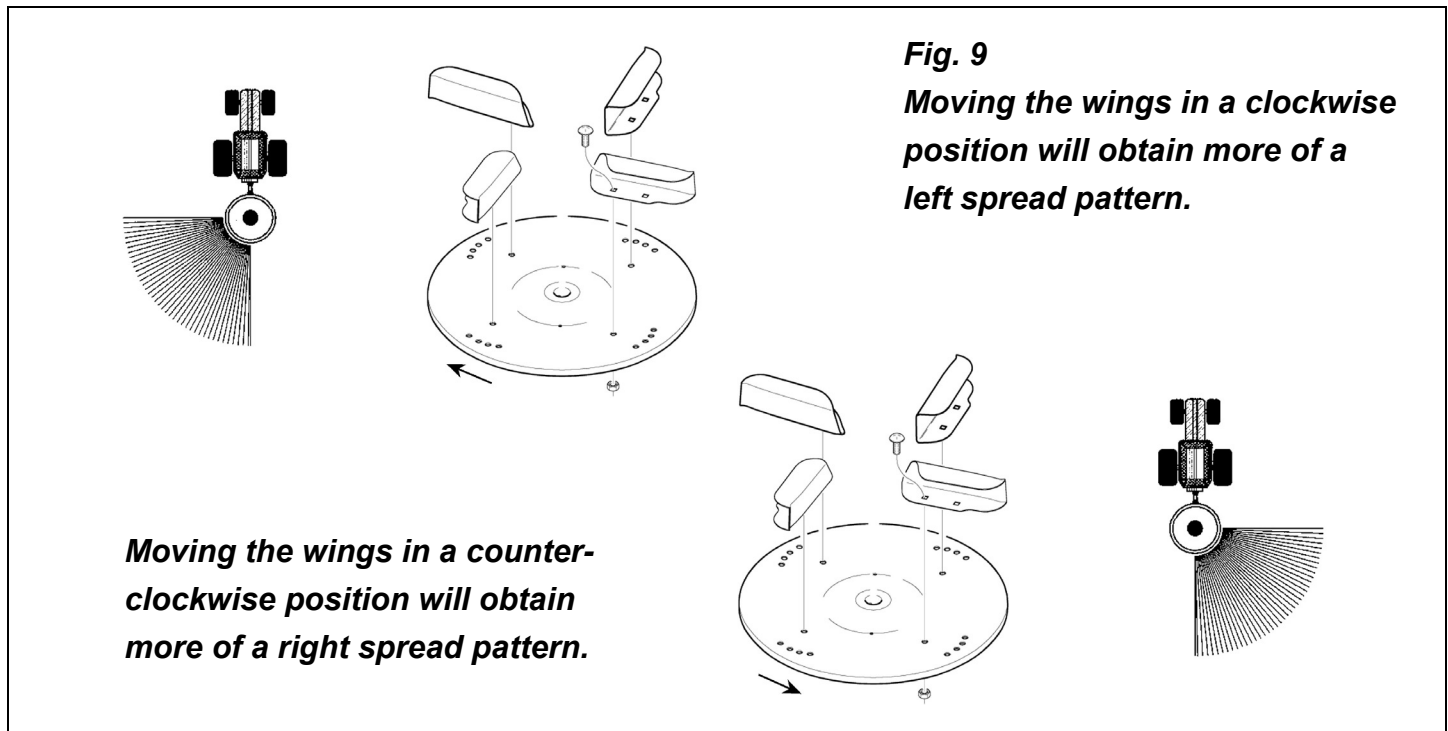

### 3.07 - Uneven Terrain



**WARNING: Be careful of roll-over when operating tractor and spreader over uneven ground.**

The following precautions should always be observed when working on uneven terrain:

1. In extremely uneven terrain rear wheel weights, front tractor weights, and/or tire ballast should be used to improve stability.
2. Observe the type of terrain and develop a safe working pattern.
3. Whenever traction or stability is doubtful, first test drive over the terrain.
4. Operate the implement up and down steep slopes, not across slopes, to prevent the tractor from tipping. Avoid sudden stops and starts, and slow down before changing directions on a slope.
5. Pass diagonally through sharp dips and avoid sharp drops to prevent hanging up the tractor and implement.
6. Slow down on sharp turns and slopes to prevent tipping or loss of control.
7. Watch for holes, roots or other hidden objects. Do not use near the edge of a gully, ditch or stream bank.

<sup>8</sup> See Table 4 - Models SS1036B, SS2036B, SS1067B & SS2067B swath spread patterns, page 25.

## 4 - MAINTENANCE



**DANGER:** Stop engine, lock parking brake and remove key before performing any service or maintenance.

Always use personal protection devices, such as a breathing mask capable of filtering toxic powders, safety glasses and gloves, when performing maintenance. Refer to chemical manufacturer's label for specific safety information.

Keep fingers out of slots to prevent injury.

### 4.01 - Maintenance Safety



1. Good maintenance is your responsibility.
2. Keep service area clean and dry. Be sure electrical outlets and tools are properly grounded. Use adequate light for the job at hand.
3. Make sure there is plenty of ventilation. Never operate the engine of the towing vehicle in a closed building. The exhaust fumes may cause asphyxiation.
4. Make no repair or adjustments with the tractor engine running. Before working on the machine, disengage the PTO, shut off the engine, set the brakes, and remove the ignition key.
5. Be certain all moving parts on attachment have come to a complete stop before attempting to perform maintenance.
6. Never work under equipment unless it is blocked securely.
7. Always use personal protection devices such as eye, hand and hearing protectors, when performing any service or maintenance.
8. Never trust the tractor hydraulics alone to support the machine. Before repairing or adjusting the machine, it should be lowered and allowed to rest on a stand.
9. Periodically tighten all bolts, nuts and screws and check that all cotter pins are properly installed to ensure unit is in a safe condition.
10. When completing a maintenance or service function, make sure all safety shields and devices are installed before placing unit in service.
11. Do not attempt to mount a tire unless you have the proper equipment and experience to do the job.
12. Inflating or servicing tires can be dangerous. Whenever possible, trained personnel should be called to service and/or mount tires.
13. After servicing, be sure all tools, parts and service equipment are removed.
14. Never replace hex bolts with less than grade five bolts unless otherwise specified, i.e., shear bolts<sup>9</sup>.
15. Where replacement parts are necessary for periodic maintenance and servicing, genuine replacement parts must be used to restore your equipment to original specifications. The Company will not claim responsibility for use of unapproved parts and/or accessories and other damages as a result of their use.

<sup>9</sup> Refer to Table 1 - Torque Specifications, for head identification marking, page 24.

16. Unauthorized modifications to the machine may impair the function and/or safety of the machine and reduce its life. If equipment has been altered in any way from original design, the manufacturer does not accept any liability for injury or warranty.

## 4.02 - Service

### Before beginning work:

1. Apply a thick layer of grease to all exposed moving parts.
2. Apply a film of biodegradable oil in crevices and corners in order to keep corrosive material from rusting areas that are difficult to clean.

### After each use:

1. Be sure to thoroughly wash the machine without using excessive pressure especially on the moving parts. It is particularly important to wash the implement after using salt or fertilizer. This will help prevent the caustic chemicals in the salt and fertilizer from destroying the metal of the machine.
2. Carefully dry the machine.
3. Apply a thick layer of grease to all exposed moving parts.
4. Apply a film of biodegradable oil in crevices and corners.

### After seasonal use it is important to perform the following for prolonged storage:

1. Wash and dry the spreader carefully.
2. Inspect the spreader and replace worn or damaged parts. If corrosive material has eaten under the paint, clean off the area with a wire brush and touch up with primer and paint.
3. Tighten all hardware.
4. Apply a thick layer of grease to all exposed moving parts.
5. Apply a film of biodegradable oil in crevices and corners.
6. Cover the spreader from the elements in order to have it in perfect condition for the start of the next season.

**NOTE:** The gearbox has been filled with EP grade grease from the factory. The grease never needs replacing unless internal work is done to the gearbox. If necessary add SAE 90 oil through the suitable cap by giving the proper inclination to the fertilizer spreader.

## 4.03 - Driveline



**DANGER:** Only use the original driveline supplied with this implement and always with the safety shielding. Carefully read and file away the driveline operator's manual supplied by the manufacturer. The following does not substitute the information found in the driveline manual.

**IMPORTANT:** Always check driveline length during initial setup and when connecting to a different tractor.

In the collapsed position the driveline should be approximately 2" from bottoming out to prevent possible damage to the tractor or implement. When the driveline is in the maximum extended position, the ideal minimum overlap of the two halves should be approximately 6" (see fig. 10).

If determined that the driveline is too long, follow these procedures to adjust the length:

1. Separate the two driveline halves. Connect one half to the tractor PTO and the other half to the implement.
2. Raise and lower the implement with the 3 point hitch to find the position where the driveline is shortest. Hold the half shafts side by side and mark the desired length on the outer female tube guard leaving a 1 ½" gap between the end of the guard tube and bell guard.
3. Cut off both guard tubes the same amount as marked in step 2.
4. Shorten both drive tubes the same amount as guard tubes.
5. De-burr and clean filings from drive tubes and apply grease to outside of inner telescoping tube.
6. Reassemble the driveline halves and connect to tractor and implement. Raise and lower implement again to be sure driveline does not bottom out in its shortest position and has a minimum overlap of 6" in the longest position.
7. Install both driveline safety chains. One should be hooked in a hole on the outer driveline yoke shield and to the tractor to restrict outer shield rotation. The second one should be hooked in a hole on the inner driveline yoke shield and to the implement to restrict inner shield rotation.

If determined that the driveline is too short for your tractor, contact your local dealer.

**Fig. 10**

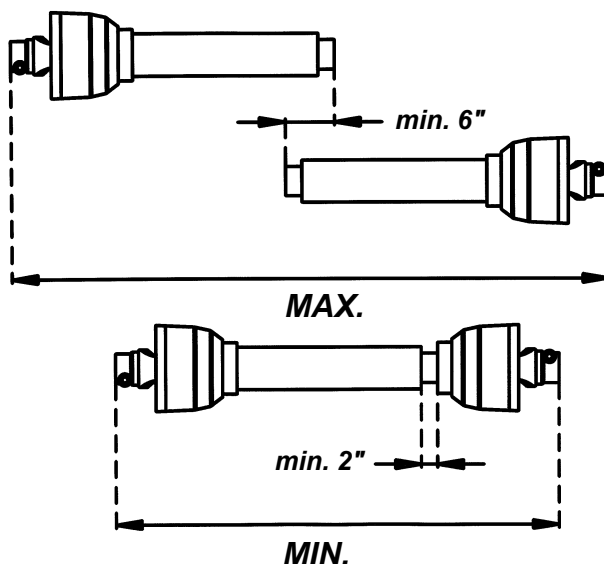

**CAUTION:** Always work with the driveline as straight as possible. This will prolong its life and that of its components. It is advised not to work at an angle greater than 15 degrees.

## 4.04 - Transport









**CAUTION:** Do not tow tractor and spreader behind other vehicles. Use a properly equipped trailer with heavy tie-downs for towing operations.

Before transporting:

1. Always select a safe ground speed that is appropriate for the terrain.
2. Beware of traffic on public roads. Install a SMV (Slow Moving Vehicle) sign when traveling on roads or streets. Comply with all federal, state and local laws.
3. Reduce ground speed when turning and take care that the spreader does not strike obstacles such as trees, fences or buildings.
4. Always disengage PTO before raising spreader to transport position.

**TABLE 1 - TORQUE SPECIFICATIONS**

Metric (ISO) treaded bolts head marking							Inch (SAE) treaded bolts head marking								
	Class 5.8		Class 8.8		Class 10.9			Grade 2		Grade 5		Grade 8			
Bolt size mm	Thread mm	N.m	ft-lb	N.m	ft-lb	N.m	ft-lb	Bolt size inch	Thread inch tpi	N.m	ft-lb	N.m	ft-lb	N.m	ft-lb
M5	0.8	4	3	6	4	9	7	1/4"	20	7	5	11	8	16	12
M6	1	6	4	10	7	15	11	1/4"	28	8	6	13	10	19	14
M8	1.25	16	12	25	18	36	27	5/16"	18	15	11	24	17	33	25
M8	1	17	13	26	19	38	28	5/16"	24	17	13	26	19	37	27
M10	1.5	31	23	48	35	71	52	3/8"	16	27	20	42	31	59	44
M10	1.25	33	24	51	38	75	55	3/8"	24	31	23	47	35	67	49
M10	1	35	26	53	39	78	58	7/16"	14	43	32	67	49	95	70
M12	1.75	54	40	84	62	123	91	7/16"	20	48	36	75	55	106	78
M12	1.5	56	41	87	64	128	94	1/2"	13	66	48	102	75	144	106
M12	1.25	59	44	90	66	133	98	1/2"	20	75	55	115	85	163	120
M14	2	84	62	133	98	195	144	9/16"	12	95	70	147	109	208	154
M14	1.5	94	69	142	105	209	154	9/16"	18	106	79	164	121	232	171
M16	2	131	97	206	152	302	223	5/8"	11	132	97	203	150	287	212
M16	1.5	141	104	218	161	320	236	5/8"	18	149	110	230	170	325	240
M18	2.5	181	133	295	218	421	310	3/4"	10	233	172	361	266	509	376
M18	2	196	145	311	229	443	327	3/4"	16	261	192	403	297	569	420
M18	1.5	203	150	327	241	465	343	7/8"	9	226	167	582	430	822	606
M20	2.5	256	189	415	306	592	437	7/8"	14	249	184	642	473	906	668
M20	1.5	288	212	454	335	646	476	1"	8	339	250	873	644	1232	909
M22	2.5	344	254	567	418	807	595	1"	12	371	273	955	704	1348	995
M22	1.5	381	281	613	452	873	644	1-1/8"	7	480	354	1077	794	1746	1288
M24	3	444	327	714	526	1017	750	1-1/8"	12	539	397	1208	891	1958	1445
M24	2	488	360	769	567	1095	808	1-1/4"	7	677	500	1519	1120	2463	1817
M27	3	656	484	1050	774	1496	1103	1-1/4"	12	750	553	1682	1241	2728	2012
M27	2	719	530	1119	825	1594	1176	1-3/8"	6	888	655	1992	1469	3230	2382
M30	3.5	906	668	1420	1047	2033	1499	1-3/8"	12	1011	746	2268	1673	3677	2712
M30	2	1000	738	1600	1180	2250	1659	1-1/2"	6	1179	869	2643	1949	4286	3161
M36	4	1534	1131	2482	1830	3535	2607	1-1/2"	12	1326	978	2974	2194	4823	3557

When using lock washers with nuts, increase torque values by 5%.

**TABLE 2 - FERTILIZER SPREADER - TECHNICAL FEATURES**

For tractors from 16 to 30 HP, PTO 540 rpm, 3 point hitch cat. 1								
Model	HP	Hopper capacity cu. ft.	Carrying weight lbs.	Weight lbs.	Loading height	Loading width	Spreading width ft.	Driveline 1 3/8"
SS1023B	16-30	3.5	226	81	31"	32"	23'	ASAE cat. 1
SS1036B	16-30	5.6	362	102	34"	35"	23'	ASAE cat. 1
SS2036B	16-30	5.6	362	102	34"	35"	23'	ASAE cat. 1
SS1067B	16-30	10.6	678	125	40"	42"	46'	ASAE cat. 1
SS2067B	16-30	10.6	678	125	40"	42"	46'	ASAE cat. 1



**TABLE 3 - MODEL SS1023B SWATH SPREAD PATTERNS (lbs/acre)**

Lever position	Spreading width 20 feet		
	2.5 mph	3.75 mph	5 mph
1	89	45	39
2	143	89	71
3	223	152	107
4	312	196	152
5	419	277	205
6	553	330	277
7	651	410	321
8	767	473	384
9	874	562	437
10	999	625	500

**TABLE 4 - MODELS SS1036B, SS2036B, SS1067B & SS2067B SWATH SPREAD PATTERNS (lbs/acre)**

Lever position	Spreading width 46 feet		
	2.5 mph	5 mph	7.5 mph
1	50	39	16
2	123	61	43
3	246	123	82
4	369	184	123
5	492	246	166
6	-	307	201
7	-	369	246
8	-	430	282
9	-	492	323

## 5 - REPAIR PROCEDURES



**CAUTION:** All repair procedures must be done by authorized dealerships. It is not recommended that untrained individuals perform any repair work.

### 5.01 - Suggested Spare Parts

It is suggested that the following spare parts be kept on hand for the spreader at all times to prevent a minor problem from delaying work:

#### Models SS1023B, SS1036B & SS2036B

Description	Quantity
Spreader disc (5BP501650B)	1
Threaded Bushing (5BP501622B)	1
Nut M30 (5BP501651B)	1

#### Models SS1067B & SS2067B

Description	Quantity
Spreader disc wings (5BP501598B)	4
Stirrer (5BP501597B)	1

### 5.02 - Storage

After seasonal use it is important to perform the following for prolonged storage:

1. Empty hopper of product before unhooking it from the tractor.
2. Wash and dry the spreader carefully.
3. Inspect the spreader and replace worn or damaged parts. If corrosive material has eaten under the paint, clean off the area with a wire brush and touch up with primer and paint.
4. Tighten all hardware.
5. Grease or oil all areas indicated under Maintenance<sup>10</sup>.
6. Apply a thick layer of grease to all exposed moving parts.
7. Cover the spreader from the elements in order to have it in perfect condition for the start of the next season.
8. Make sure all parked machines are on a hard, level surface, and engage all safety devices.
9. Do not permit children to play on or around the stored unit.

#### Touch up paint available:

Part #	Description
5BP7300007	Primer, gray - aerosol spray can
5BP7300011	Paint, green - aerosol spray can
5BP7300010	Paint, black - aerosol spray can

<sup>10</sup> See Chapter 4 - Maintenance.

## 6 - TROUBLESHOOTING



**WARNING:** Be sure tractor engine is off, parking brake is locked, and key is removed before making any adjustments.

PROBLEM	POSSIBLE CAUSE	SOLUTION
Non uniform spread pattern.	Spreader disc wings not positioned properly. Wrong gate opening.	Position spreader disc wings to the proper setting (see section 3.06 - Operating Techniques). Adjust gate openings.
Product not flowing to spreader disc.	Wet product. Powdered product.	Use dry product only. Use optional tumbling agitator.
PTO shaft turning but not the gearbox output shaft.	Roll pin missing or sheared on the spreader disc shaft. Broken ring or pinion gear.	Replace roll pin. Replace ring or pinion gear.
Narrow spread width.	Incorrect PTO speed. Hopper too far backwards.	Increase PTO speed to 540 rpm. Shorten the tractor's top link to position spreader so it runs level or inclined slightly forward toward the tractor.

## 7 - PRE-DELIVERY CHECKLIST

**To the dealer: Inspect the machine thoroughly after assembly to assure it is functioning properly before delivering it to the customer. The following checklist is a reminder of points to cover. Check off each item as it is found satisfactory or after proper adjustment is made.**

- Gearbox oil level.
- Guards and shield properly fastened.
- Lubrication of grease fittings.
- All hardware properly tightened.
- All decals properly located and readable (**see fig. 6**).
- Overall condition (touch up scratches, clean and polish).
- Test run, check for excessive vibration or overheating of bearings.
- Operator's Manual.

**Review the Operator's Manual with the customer. Explain the following:**

- Warranty.
- Safe operation and service.
- Correct machine installation and operation.
- Daily and periodic lubrication, maintenance and inspections.
- Troubleshooting.
- Operational procedures and storage.
- Parts and service.
- Fill out the Pre-Delivery Checklist and the on-line Warranty Registration form.
- Give customer the Operator's Manual and encourage the customer to read the manual carefully.

**IMPORTANT: The dealer must complete the Warranty Registration, located on the Frontier website. Warranty claims will be denied if the Warranty Registration has not been completed.**

Model Number: \_\_\_\_\_

Serial Number: \_\_\_\_\_

Delivery Date: \_\_\_\_\_

Dealer's Signature: \_\_\_\_\_





# FERTILIZER SPREADERS

**SS1023B**

**SS1036B**

**SS1067B**

**SS2036B**

**SS2067B**

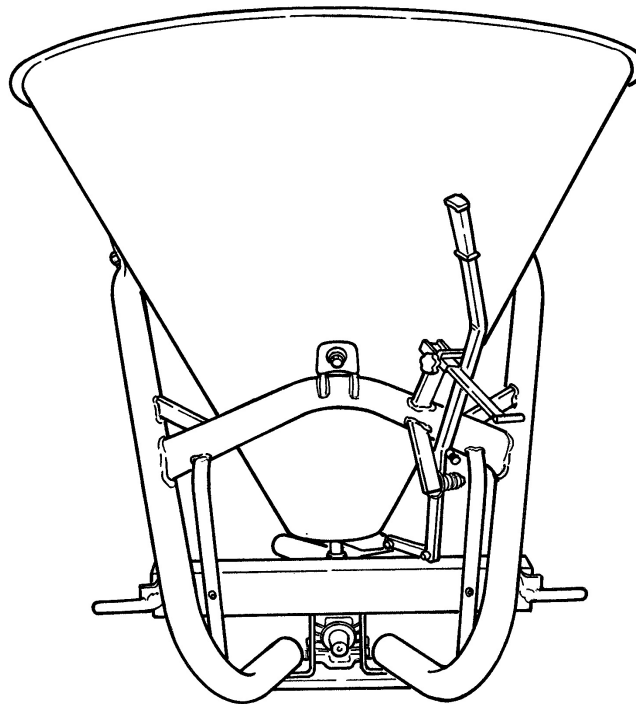

**Note:** Serial #'s with the XF prefix are subsequent to serial numbers with the BC prefix. For example: A reference to "serial # BC... 739197 & above" will also include all serial numbers with an XF prefix.

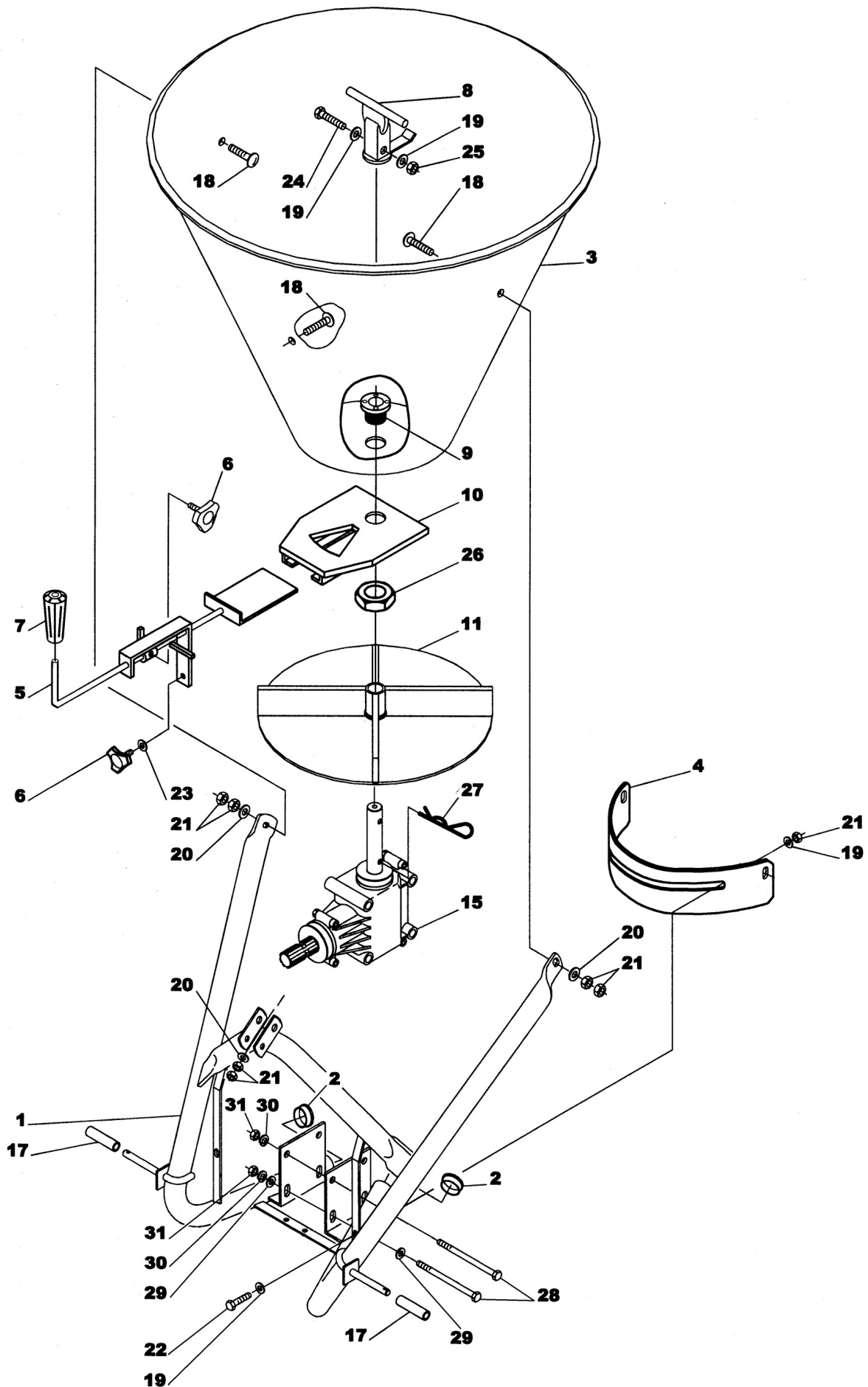



Ref.	Part #	Description	Qty.
1	5BP501660B	Frame w/cat. 0/1 hitch; SS1023B #XF...287132 & below <sup>11</sup>	1
	5BP0014620	Frame w/cat. 1 hitch; SS1023B #XF...287133 & above	1
2	5BP0014616	Rubber cap Ø45	2
3	5BP501661B	Hopper, steel; SS1023B	1
4	5BP501668B	Guard	1
5	5BP501630B	Flow control assembly	1
6	5BP501631B	Adjustment knob M6x16	2
7	5BP501639B	Adjustment knob	1
8	5BP501123B	Stirrer	1
9	5BP501622B	Threaded bushing M20	1
10	5BP501652B	Mobile shutter	1
11	5BP501650B	Spreader disc	1
15	5BP501670B	Gearbox, complete	1
17	5BP0014710	Bushing cat. 0/1; #XF...287132 & below	2
18	5BP501663B	Bolt CR M08-1.25x25 C4.6 Z	3
19	5BP0015230	Washer flat Ø8 W	6
20	5BP0014514	Washer fender Ø8 Z	7
21	5BP0001806	Nut HH M08-1.25 C6 Z TK	8
22	5BP0046454	Bolt HH M08-1.25x16 C8.8 Z F	2
23	5BP0011209	Washer fender Ø6 Z	1
24	5BP0015220	Bolt HH M08-1.25x35 C8.8 Z F	1
25	5BP0091384	Nut ES M08-1.25 Z TK	1
26	5BP501651B	Nut HH M30-2.00 C6 Z TN	1
27	5BP0041291	Hairpin cotter Ø5 Z	1
28	5BP0015273	Bolt HH M10-1.50x110 C8.8 Z P	4
29	5BP0002034	Washer flat Ø10 W	4
30	5BP0001280	Washer lock Ø10 Z	4
31	5BP0090150	Nut HH M10-1.50 C6 Z MD	4
	5BP950355B	Spreader safety decal kit complete	-
	5BP950109B	Decal "DANGER - Avoid injury from PTO"	1
	5BP950338B	Decal "WARNING - Toxic chemical hazard"	1
	5BP950339B	Decal "WARNING - Thrown objects, moving parts hazard"	1
	5BP950417B	Decal "CAUTION - To avoid serious injury"	1
	5BP950942B	Decal "spread chart"; SS1023B	1
	5BP950439B	Decal selector "1-10" large	1
	5BP950440B	Decal selector "1-10" small	1
	5BP950346B	Decal "FRONTIER"	1
	5BP950361B	Decal "SS1023B"	1
	5BP960376B	Operator's & Parts Manual Frontier Fertilizer Spreaders SS1023B, SS1036B, SS2036B, SS1067B & SS2067B	-

<sup>11</sup> Interchangeable with part #5BP0014620 if spreader is used on a tractor with a cat. 1 hitch.

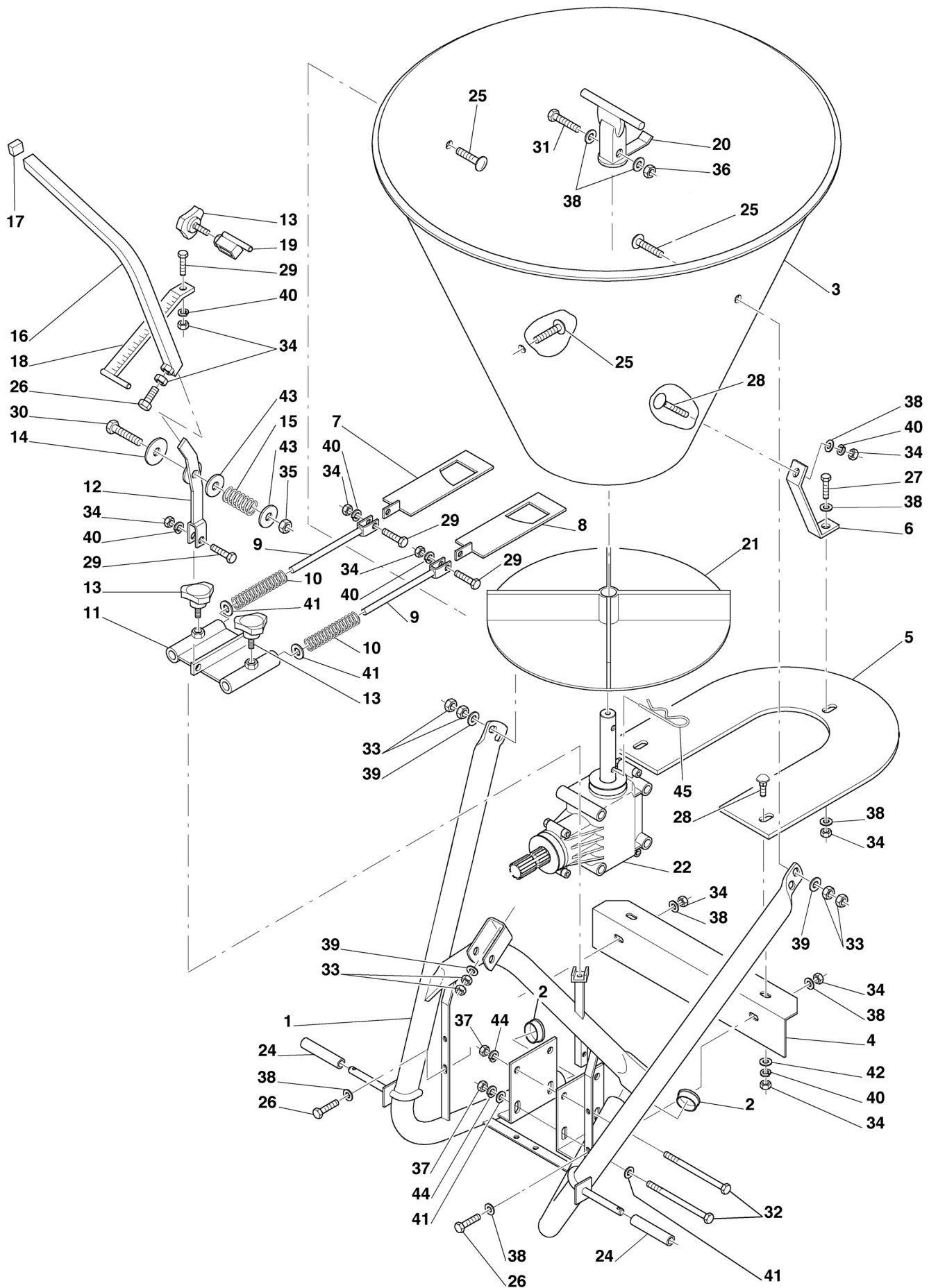

Ref.	Part #	Description	Qty.
1	5BP0014601	Frame w/cat. 0/1 hitch; SS1036B, #XF...288985 & below <sup>12</sup>	1
	5BP0014625	Frame w/cat. 1 hitch; SS1036B, #XF...288986 & above	1
2	5BP0014616	Rubber cap Ø45	2
3	5BP0214624	Hopper; SS1036B	1
4	5BP0014630	Protection	1
5	5BP0014632	Protection	1
6	5BP0014338	Attachment plate	1
7	5BP0114640	Shutter, right	1
8	5BP0214640	Shutter, left	1
9	5BP0014641	Tie rod	2
10	5BP502024B	Tension spring	2
11	5BP502025B	Shutter guide plate	1
12	5BP502002B	Lever bracket	1
13	5BP501589B	Adjustment knob M8x15	3
14	5BP501585B	Washer flat nylon Ø12	1
15	5BP501586B	Spring	1
16	5BP0014643	Lever	1
17	5BP0014391	Rubber cap	1
18	5BP0014645	Scaled rod	1
19	5BP502008B	Lever stop	1
20	5BP501597B	Stationary stirrer	1
21	5BP0014647	Spreader disc	1
22	5BP0014690	Gearbox, complete	1
24	5BP0014710	Bushing cat. 0/1; #XF...288985 & below	2
25	5BP501663B	Bolt CR M08-1.25x25 C4.6 Z	3
26	5BP0015012	Bolt HH M08-1.25x20 C8.8 Z F	3
27	5BP0046454	Bolt HH M08-1.25x16 C8.8 Z F	1
28	5BP0084289	Bolt CR M08-1.25x20 C4.6 Z	3
29	5BP0046543	Bolt HH M08-1.25x30 C8.8 Z F	4
30	5BP0007128	Bolt HH M12-1.75x80 C8.8 Z F	1
31	5BP0014427	Bolt HH M08-1.25x45 C8.8 Z P	1
32	5BP0015273	Bolt HH M10-1.50x110 C8.8 Z P	4
33	5BP0001806	Nut HH M08-1.25 C6 Z TK	6
34	5BP0046545	Nut HH M08-1.25 C6 Z MD	11
35	5BP0013345	Nut ES M12-1.75 Z TK	1
36	5BP0091384	Nut ES M08-1.25 Z TK	1
37	5BP0090150	Nut HH M10-1.50 C6 Z MD	4
38	5BP0015230	Washer flat Ø8 W	9
39	5BP0014514	Washer fender Ø8 Z	3
40	5BP0003144	Washer lock Ø8 Z	7
41	5BP0002034	Washer flat Ø10 W	6
42	5BP0030157	Washer fender Ø10 Z	2
43	5BP0091435	Washer flat Ø14 W	2
44	5BP0001280	Washer lock Ø10 Z	4
45	5BP0041291	Hairpin cotter Ø5 Z	1
	5BP950369B	Decal "spread chart"; SS1036B, SS2036B, SS1067B, SS2067B	1
	5BP950432B	Decal "SS1036B"	1

<sup>12</sup> Interchangeable with part #5BP0014625 if spreader is used on a tractor with a cat. 1 hitch.

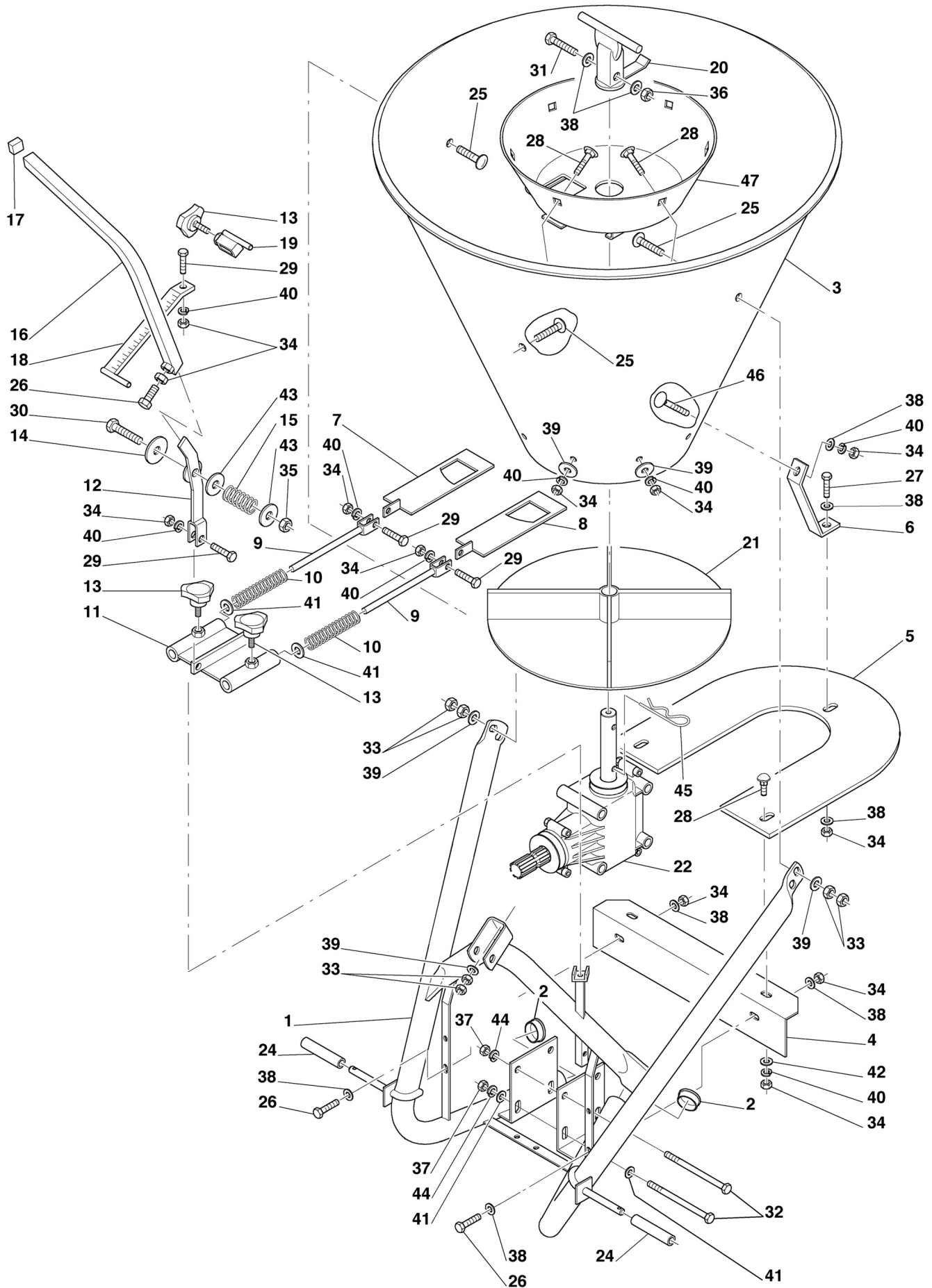

Ref.	Part #	Description	Qty.
1	5BP0014601	Frame w/cat. 0/1 hitch; SS2036B, #XF...288985 & below <sup>13</sup>	1
	5BP0014625	Frame w/cat. 1 hitch; SS2036B, #XF...288986 & above	1
2	5BP0014616	Rubber cap Ø45	2
3	5BP0214629	Polyethylene hopper; SS2036B	1
4	5BP0014630	Protection	1
5	5BP0014632	Protection	1
6	5BP0014635	Attachment plate	1
7	5BP0114648	Shutter stainless steel, right	1
8	5BP0214648	Shutter stainless steel, left	1
9	5BP0014641	Tie rod	2
10	5BP502024B	Tension spring	2
11	5BP502025B	Shutter guide plate	1
12	5BP502002B	Lever bracket	1
13	5BP501589B	Adjustment knob M8x15	3
14	5BP501585B	Washer flat nylon Ø12	1
15	5BP501586B	Spring	1
16	5BP0014643	Lever	1
17	5BP0014391	Rubber cap	1
18	5BP0014645	Scaled rod	1
19	5BP502008B	Lever stop	1
20	5BP501597B	Stationary stirrer	1
21	5BP0014647	Spreader disc	1
22	5BP0014690	Gearbox, complete	1
24	5BP0014710	Bushing cat. 0/1; #XF...288985 & below	2
25	5BP0014619	Bolt CR M08-1.25x35 C4.6 Z	3
26	5BP0015012	Bolt HH M08-1.25x20 C8.8 Z F	3
27	5BP0046454	Bolt HH M08-1.25x16 C8.8 Z F	1
28	5BP0084289	Bolt CR M08-1.25x20 C4.6 Z	7
29	5BP0046543	Bolt HH M08-1.25x30 C8.8 Z F	4
30	5BP0007128	Bolt HH M12-1.75x80 C8.8 Z F	1
31	5BP0014427	Bolt HH M08-1.25x45 C8.8 Z P	1
32	5BP0015273	Bolt HH M10-1.50x110 C8.8 Z P	4
33	5BP0001806	Nut HH M08-1.25 C6 Z TK	6
34	5BP0046545	Nut HH M08-1.25 C6 Z MD	16
35	5BP0013345	Nut ES M12-1.75 Z TK	1
36	5BP0091384	Nut ES M08-1.25 Z TK	1
37	5BP0090150	Nut HH M10-1.50 C6 Z MD	4
38	5BP0015230	Washer flat Ø8 W	9
39	5BP0014514	Washer fender Ø8 Z	8
40	5BP0003144	Washer lock Ø8 Z	12
41	5BP0002034	Washer flat Ø10 W	6
42	5BP0030157	Washer fender Ø10 Z	2
43	5BP0091435	Washer flat Ø14 W	2
44	5BP0001280	Washer lock Ø10 Z	4
45	5BP0041291	Hairpin cotter Ø5 Z	1
46	5BP501663B	Bolt CR M08-1.25x25 C4.6 Z	1
47	5BP0014327	Hopper bottom plate, stainless steel	1
	5BP950369B	Decal "spread chart"; SS1036B, SS2036B, SS1067B, SS2067B	1
	5BP950433B	Decal "SS2036B"	1

<sup>13</sup> Interchangeable with part #5BP0014625 if spreader is used on a tractor with a cat. 1 hitch.

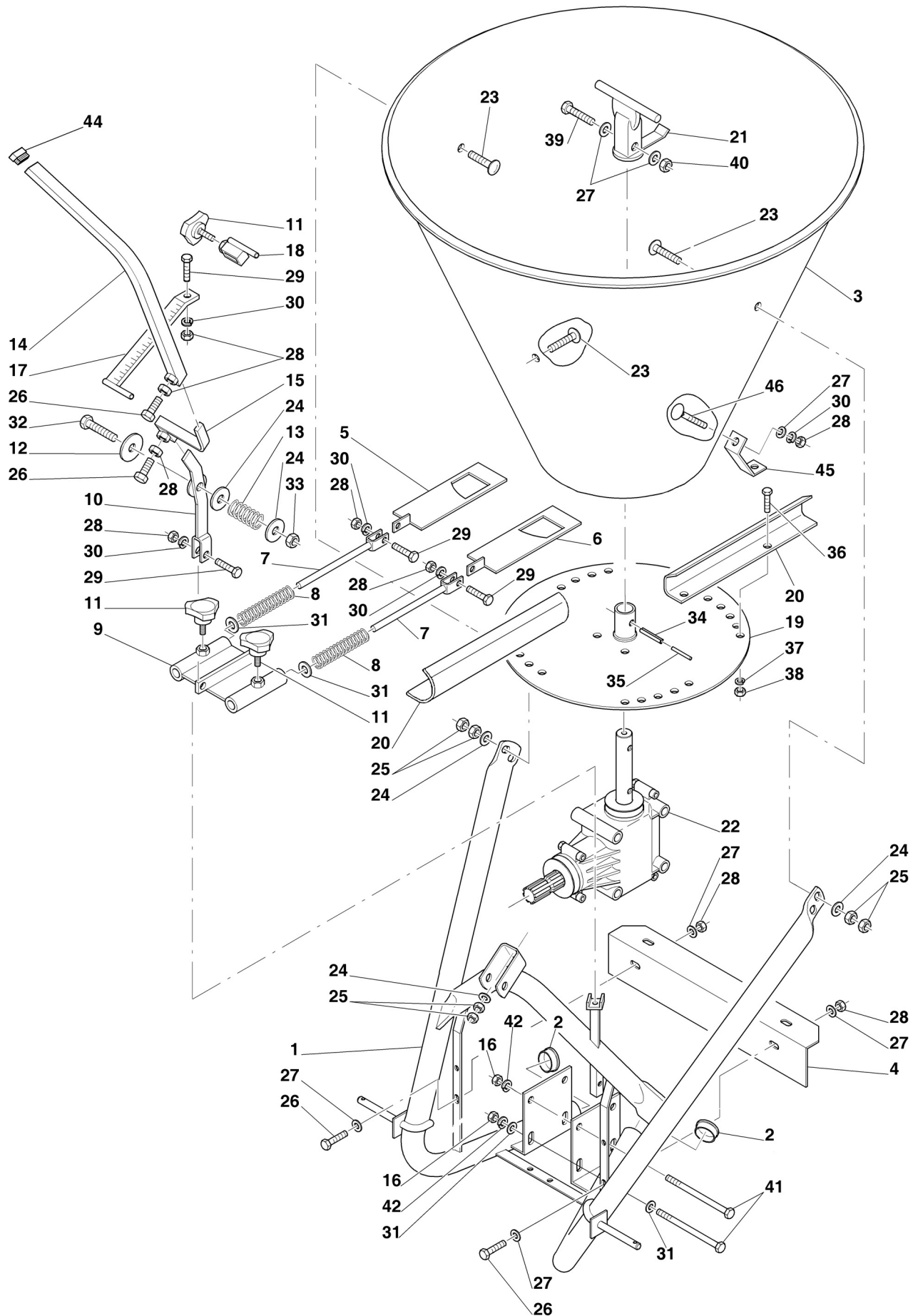

Ref.	Part #	Description	Qty.
1	5BP502011B	Frame; SS1067B, SS2067B	1
2	5BP502020B	Rubber cap Ø60	2
3	5BP502014B	Hopper, steel; SS1067B	1
4	5BP502013B	Protection	1
5	5BP502009B	Shutter, right	1
6	5BP502003B	Shutter, left	1
7	5BP502004B	Tie rod	2
8	5BP502024B	Tension spring	2
9	5BP502025B	Shutter guide plate	1
10	5BP502002B	Lever bracket	1
11	5BP501589B	Adjustment knob M8x15	3
12	5BP501585B	Washer flat nylon Ø12	1
13	5BP501586B	Spring	1
14	5BP0014380	Lever	1
15	5BP0014384	Hitch lever	1
16	5BP0090150	Nut HH M10-1.50 C6 Z MD	4
17	5BP0014396	Scaled rod	1
18	5BP502008B	Lever stop	1
19	5BP501599B	Spreader disc, steel	1
20	5BP501598B	Spreader wing, steel	4
21	5BP501597B	Stationary stirrer	1
22	5BP0014690	Gearbox, complete	1
23	5BP0051073	Bolt CR M12-1.75x30 C4.6 Z	3
24	5BP0091435	Washer flat Ø14 W	5
25	5BP0001106	Nut HH M12-1.75 C6 Z MD	6
26	5BP0015012	Bolt HH M08-1.25x20 C8.8 Z F	4
27	5BP0015230	Washer flat Ø8 W	7
28	5BP0046545	Nut HH M08-1.25 C6 Z MD	9
29	5BP0046543	Bolt HH M08-1.25x30 C8.8 Z F	4
30	5BP0003144	Washer lock Ø8 Z	5
31	5BP0002034	Washer flat Ø10 W	6
32	5BP0007128	Bolt HH M12-1.75x80 C8.8 Z F	1
33	5BP0013345	Nut ES M12-1.75 Z TK	1
34	5BP0029247	Roll pin Ø8x40	1
35	5BP501596B	Roll pin Ø5x40	1
36	5BP0036319	Bolt HH M06-1.00x16 C8.8 Z F	8
37	5BP0046536	Washer lock Ø6 Z	8
38	5BP501603B	Nut HH M06-1.00 C6 Z TK	8
39	5BP0014427	Bolt HH M08-1.25x45 C8.8 Z P	1
40	5BP0091384	Nut ES M08-1.25 Z TK	1
41	5BP0015273	Bolt HH M10-1.50x110 C8.8 Z P	4
42	5BP0001280	Washer lock Ø10 Z	4
44	5BP0014391	Rubber cap	1
45	5BP0014338	Attachment plate, steel hopper; SS1067B	1
46	5BP0084289	Bolt CR M08-1.25x20 C4.6 Z	1
	5BP950355B	Spreader safety decal kit complete	-
	5BP950369B	Decal "spread chart"; SS1036B, SS2036B, SS1067B, SS2067B	1
	5BP950353B	Decal "SMV"; SS1036B, SS2036B, SS1067B, SS2067B	1
	5BP950348B	Decal "SS1067B"	1

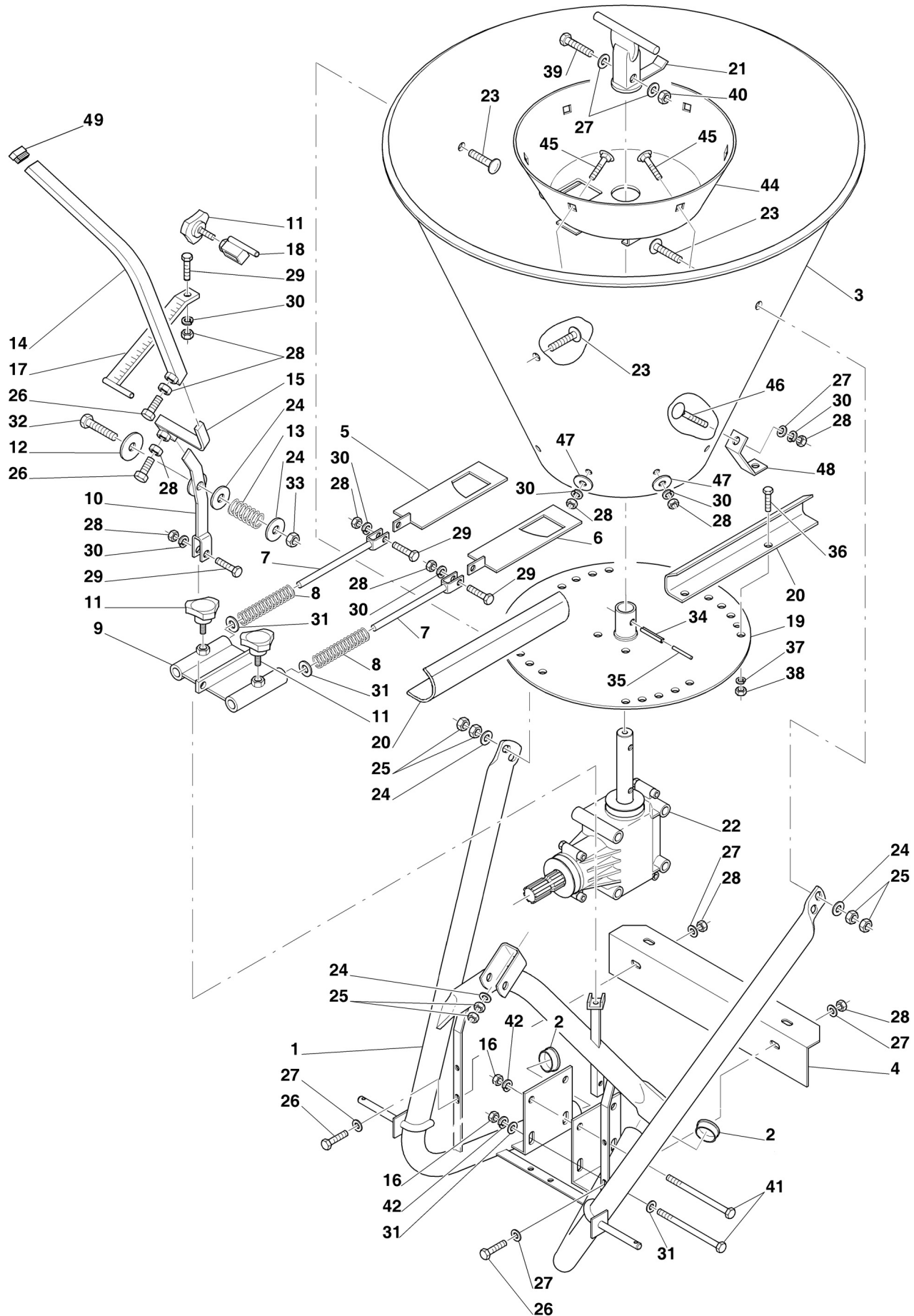



Ref.	Part #	Description	Qty.
1	5BP502011B	Frame; SS1067B, SS2067B	1
2	5BP502020B	Rubber cap Ø60	2
3	5BP0114326	Hopper polyethylene; SS2067B	1
4	5BP502013B	Protection	1
5	5BP0114340	Shutter stainless steel, right	1
6	5BP0214340	Shutter stainless steel, left	1
7	5BP502004B	Tie rod	2
8	5BP502024B	Tension spring	2
9	5BP502025B	Shutter guide plate	1
10	5BP502002B	Lever bracket	1
11	5BP501589B	Adjustment knob M8x15	3
12	5BP501585B	Washer flat nylon Ø12	1
13	5BP501586B	Spring	1
14	5BP0014380	Lever	1
15	5BP0014384	Hitch lever	1
16	5BP0090150	Nut HH M10-1.50 C6 Z MD	4
17	5BP0014396	Scaled rod	1
18	5BP502008B	Lever stop	1
19	5BP0014410	Spreader disc, stainless steel	1
20	5BP0014414	Spreader wing, stainless steel	4
21	5BP501597B	Stationary stirrer	1
22	5BP0014690	Gearbox, complete	1
23	5BP0044115	Bolt CR M12-1.75x40 C8.8 Z	3
24	5BP0091435	Washer flat Ø14 W	5
25	5BP0001106	Nut HH M12-1.75 C6 Z MD	6
26	5BP0015012	Bolt HH M08-1.25x20 C8.8 Z F	4
27	5BP0015230	Washer flat Ø8 W	7
28	5BP0046545	Nut HH M08-1.25 C6 Z MD	14
29	5BP0046543	Bolt HH M08-1.25x30 C8.8 Z F	4
30	5BP0003144	Washer lock Ø8 Z	10
31	5BP0002034	Washer flat Ø10 W	6
32	5BP0007128	Bolt HH M12-1.75x80 C8.8 Z F	1
33	5BP0013345	Nut ES M12-1.75 Z TK	1
34	5BP0029247	Roll pin Ø8x40	1
35	5BP501596B	Roll pin Ø5x40	1
36	5BP0036319	Bolt HH M06-1.00x16 C8.8 Z F	8
37	5BP0046536	Washer lock Ø6 Z	8
38	5BP501603B	Nut HH M06-1.00 C6 Z TK	8
39	5BP0014427	Bolt HH M08-1.25x45 C8.8 Z P	1
40	5BP0091384	Nut ES M08-1.25 Z TK	1
41	5BP0015273	Bolt HH M10-1.50x110 C8.8 Z P	4
42	5BP0001280	Washer lock Ø10 Z	4
44	5BP0014327	Hopper bottom plate, stainless steel	1
45	5BP0084289	Bolt CR M08-1.25x20 C4.6 Z	5
46	5BP501663B	Bolt CR M08-1.25x25 C4.6 Z	1
47	5BP0014514	Washer fender Ø8 Z	5
48	5BP0014339	Attachment plate, poly hopper	1
49	5BP0014391	Rubber cap	1
	5BP950369B	Decal "spread chart"; SS1036B, SS2036B, SS1067B, SS2067B	1
	5BP950353B	Decal "SMV"; SS1036B, SS2036B, SS1067B, SS2067B	1
	5BP950434B	Decal "SS2067B"	1

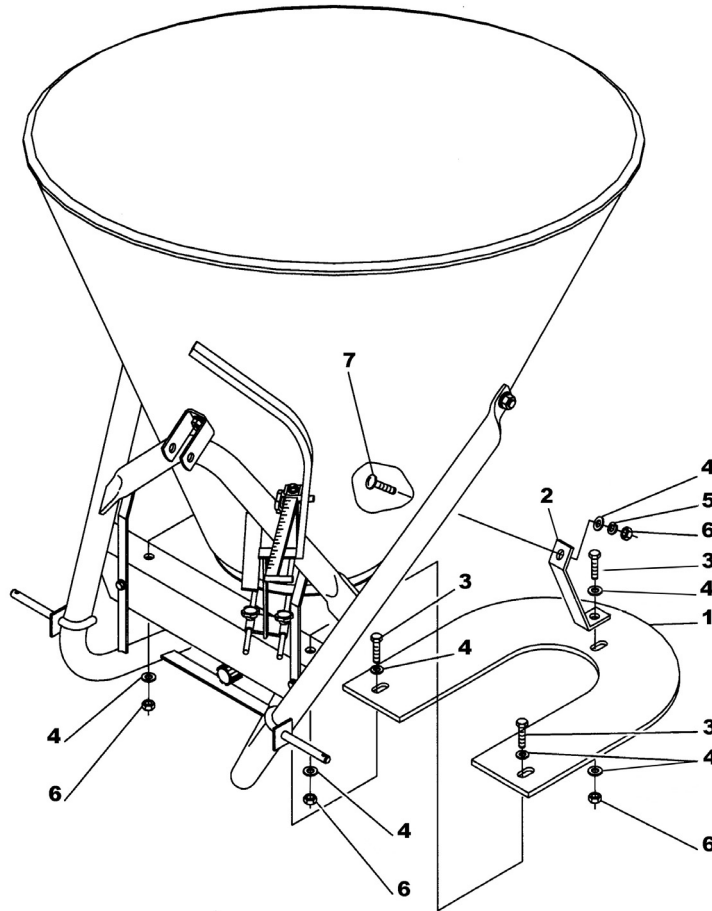

Ref.	Part #	Description	Qty.
1	5BP0014337	Protection	1
2	5BP0014338	Attachment plate, steel hopper; SS1067B	1
	5BP0014339	Attachment plate, poly hopper; SS2067B	1
3	5BP0046454	Bolt HH M08-1.25x16 C8.8 Z F	3
4	5BP0015230	Washer flat Ø8 W	7
5	5BP0003144	Washer lock Ø8 Z	1
6	5BP0046545	Nut HH M08-1.25 C6 Z MD	4
7	5BP0084289	Bolt CR M08-1.25x20 C4.6 Z; SS1067B	1
	5BP501663B	Bolt CR M08-1.25x25 C4.6 Z; SS2067B	1

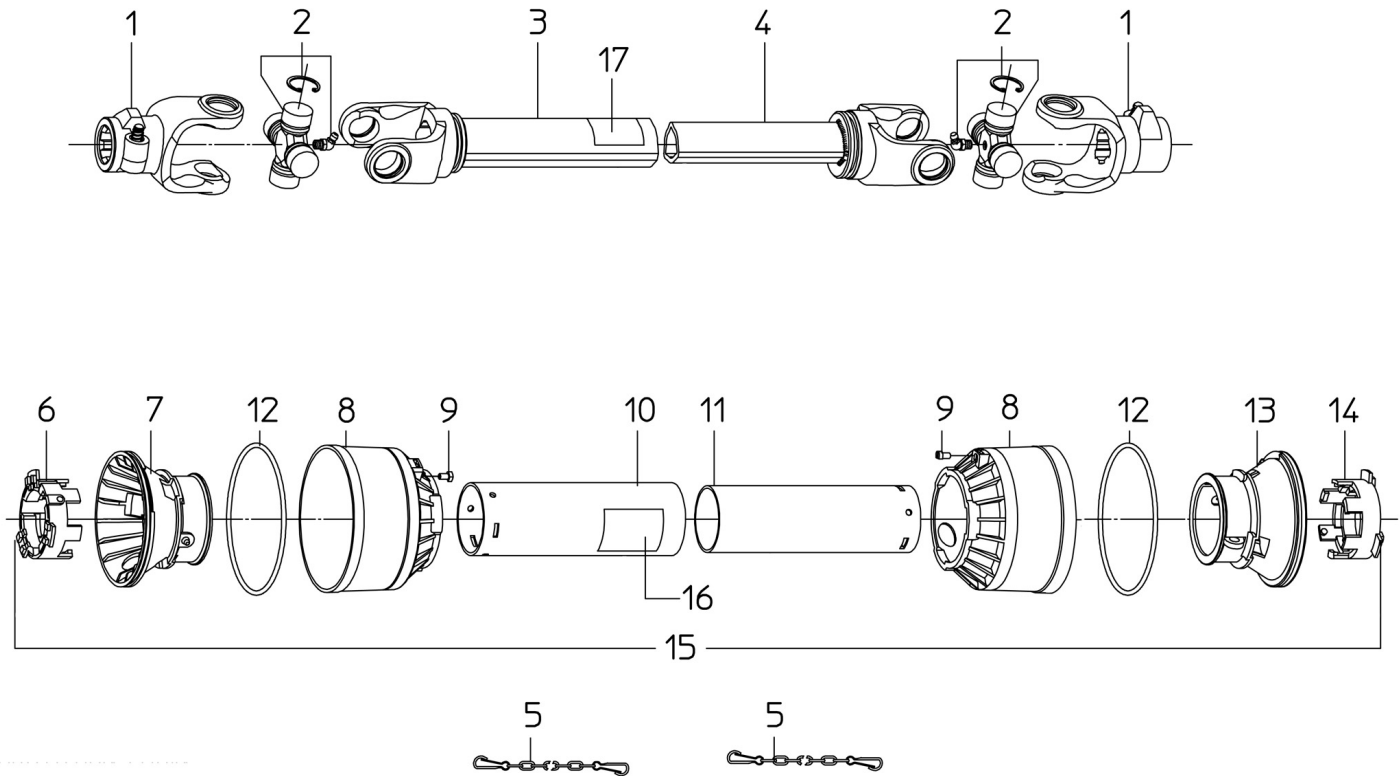

Ref.	Part #	Description	Qty.
1	5BP1021010C	PTO yoke	2
2	5BP1001005C	Cross & bearing	2
3	5BP1981034NC	Outer tube w/yoke	1
4	5BP1991035NC	Inner tube w/yoke	1
5	5BP1006065C	Chain, anti-rotation	2
6	5BP1781210C	Locking ring, outer tube	1
7	5BP1784201C	Rigid cone, outer tube	1
8	5BP1784203C	Standard cone	2
9	5BP1784212C	Pin	2
10	5BP1773032C	Shield, outer tube	1
11	5BP1872032C	Shield, inner tube	1
12	5BP1213233C	Stiffening ring	2
13	5BP1784202C	Rigid cone, inner tube	1
14	5BP1781211C	Locking ring, inner tube	1
15	5BP90SS1032C	Shield, complete <sup>14</sup>	1
16	5BP950463B	Decal "DANGER - Rotating driveline, keep away" outer shield	1
17	5BP950464B	Decal "DANGER - Guard missing, do not operate" outer tube	1
	5BP0500474	Driveline, complete <sup>15</sup>	1

<sup>14</sup> Complete shielding is no longer available, replace with part #5BP90SS1032CA.  
<sup>15</sup> Complete shaft is no longer available, replace with part #5BP0500487.

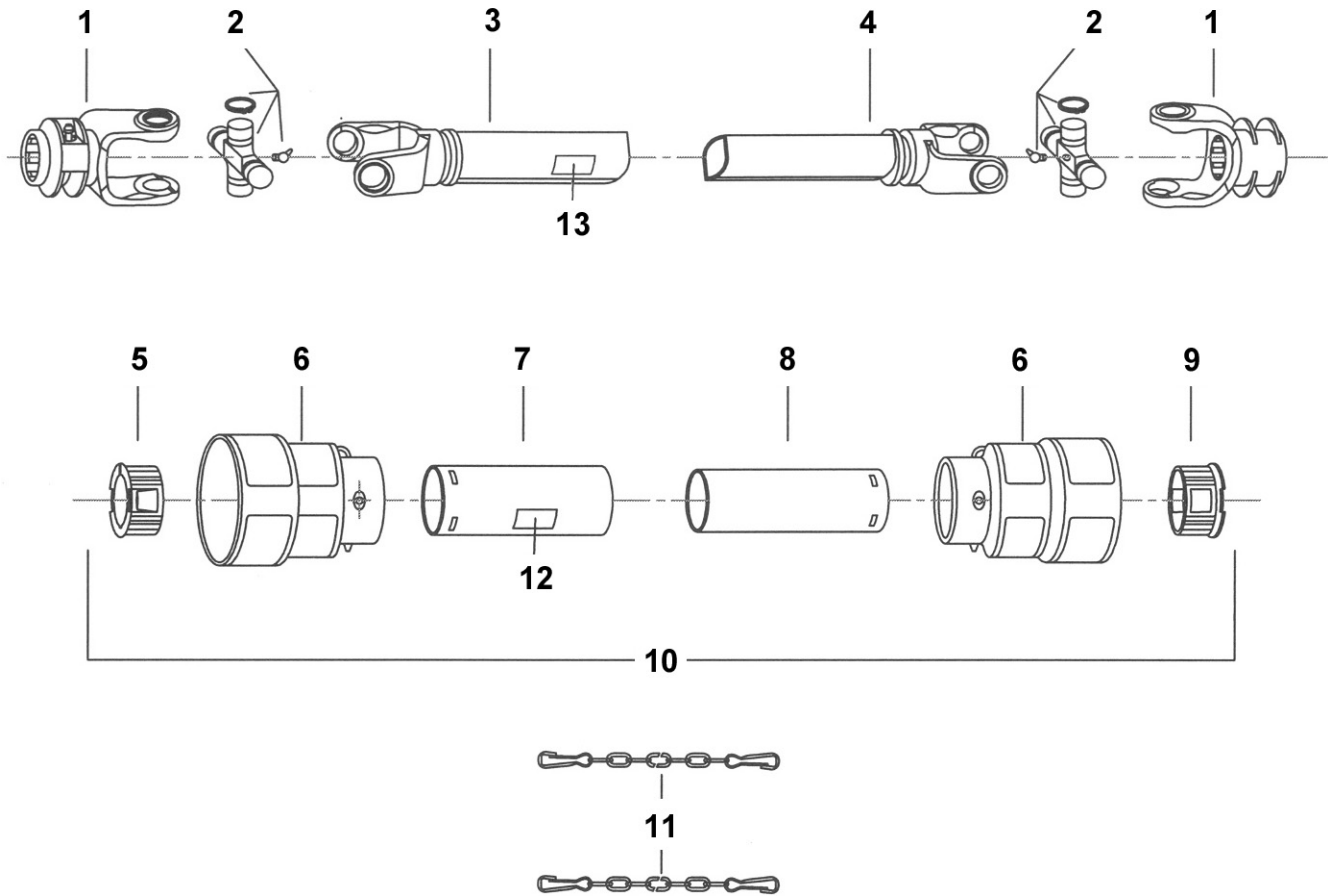

Ref.	Part #	Description	Qty.
1	5BP1021010C	PTO yoke	2
2	5BP1001005C	Cross & bearing	2
3	5BP1981034NC	Outer tube w/yoke	1
4	5BP1991035NC	Inner tube w/yoke	1
5	5BP1781210CA	Locking ring, outer tube	1
6	5BP1784203CA	Cone, outer tube	2
7	5BP1773032CA	Shield, outer tube	1
8	5BP1872032CA	Shield, inner tube	1
9	5BP1781211CA	Locking ring, inner tube	1
10	5BP90SS1032CA	Shield, complete	1
11	5BP1006065C	Chain, anti-rotation	2
12	5BP950463B	Decal "DANGER - Rotating driveline, keep away" outer shield	1
13	5BP950464B	Decal "DANGER - Guard missing, do not operate" outer tube	1
	5BP0500487	Driveline, complete	-

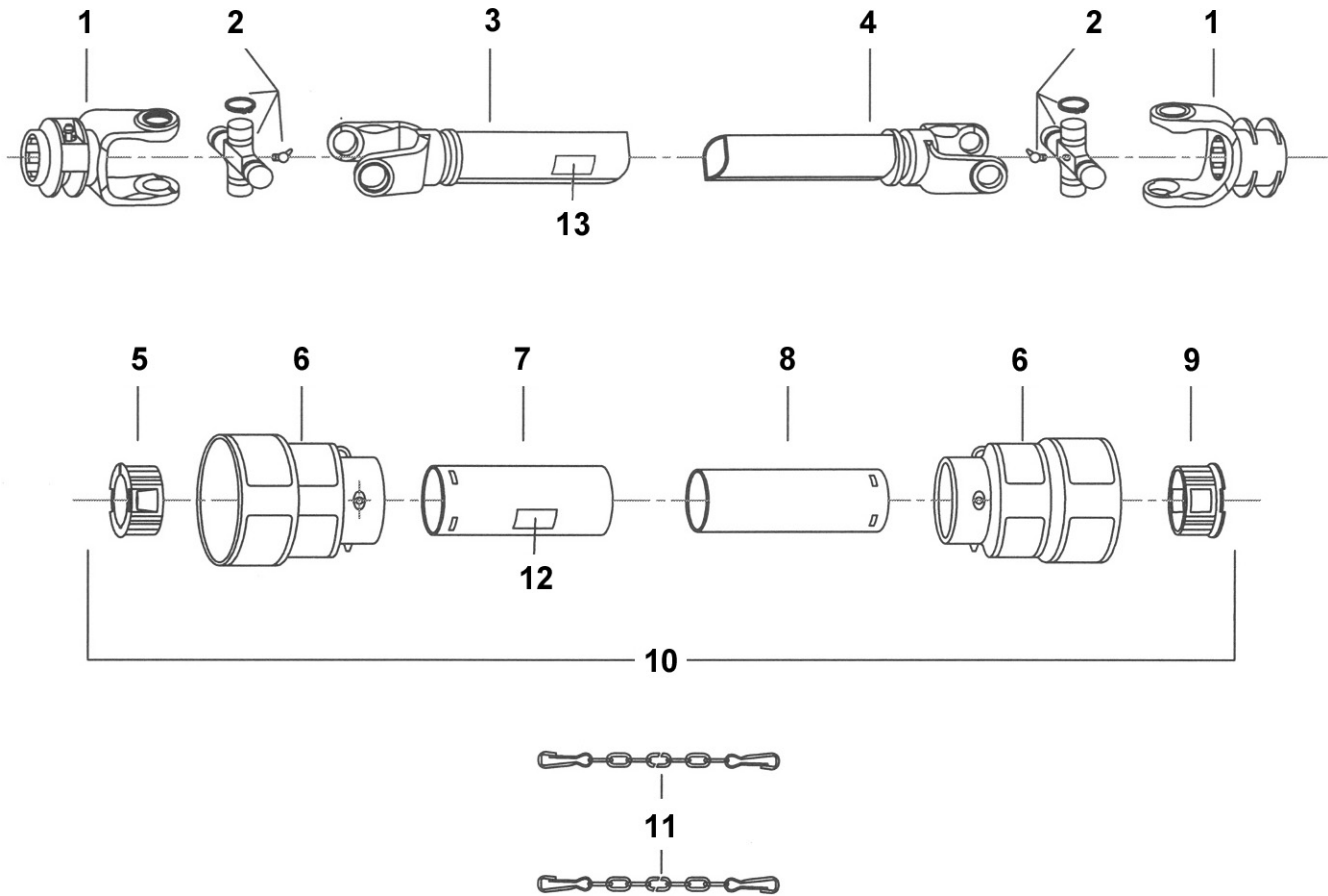

Ref.	Part #	Description	Qty.
1	5BP1021010C	PTO yoke	2
2	5BP1001005C	Cross & bearing	2
3	5BP0014444	Outer tube w/yoke	1
4	5BP0014445	Inner tube w/yoke	1
5	5BP1781210CA	Locking ring, outer tube	1
6	5BP1784203CA	Cone, outer tube	2
7	5BP0014446	Shield, outer tube	1
8	5BP0014447	Shield, inner tube	1
9	5BP1781211CA	Locking ring, inner tube	1
10	5BP0014448	Shield, complete	1
11	5BP1006065C	Chain, anti-rotation	2
12	5BP950463B	Decal "DANGER - Rotating driveline, keep away" outer shield	1
13	5BP950464B	Decal "DANGER - Guard missing, do not operate" outer tube	1
	5BP0500484	Driveline, complete	-

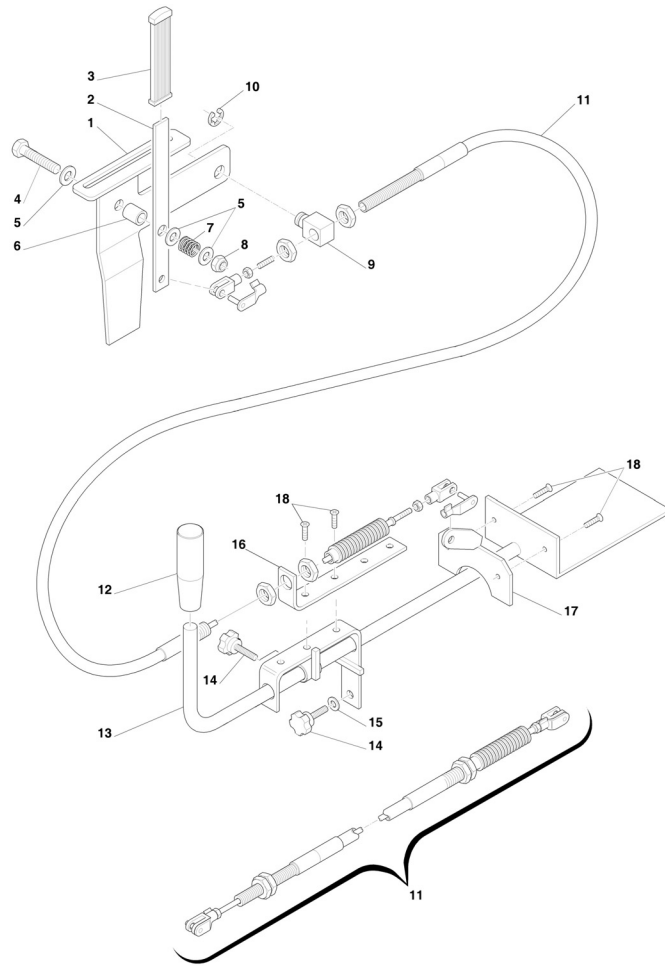

Ref.	Part #	Description	Qty.
1	5BP0014981	Support plate, remote gate control	1
2	5BP0014982	Lever, remote gate control	1
3	5BP0014983	Handle, flat grooved	1
4	5BP0014477	Bolt HH M10-1.50x60 C8.8 Z P	1
5	5BP0002034	Washer flat Ø10 W	3
6	5BP0014988	Spacer	1
7	5BP0014989	Spring	1
8	5BP0015237	Nut ES M10-1.50 Z TN	1
9	5BP0014990	Cable support	1
10	5BP0014991	Snap ring, outer Ø10	1
11	5BP0014992	Cable; until 08-2008 <sup>16</sup>	1
	5BP0014997	Cable; since 09-2008	1
12	5BP501639B	Adjustment knob	1
13	5BP0014999	Flow control assembly	1
14	5BP501631B	Adjustment knob M6x16	2
15	5BP0011209	Washer fender Ø6 Z	1
16	5BP0014993	Cable support plate	1
17	5BP0014994	Cable hitch plate	1
18	5BP0014998	Bolt CS M04-0.70x10 C8.8 Z F	4
	5BP0099856	Remote gate control, complete; SS1023B	-

<sup>16</sup> Part #5BP0014992 no longer available, customer should replace entire accessory.

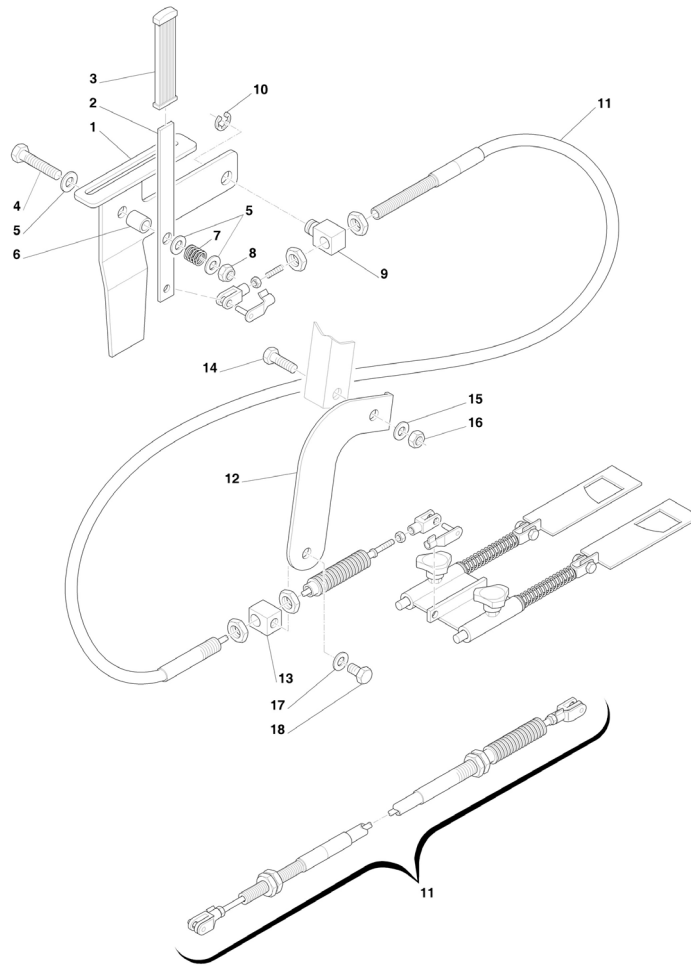

Ref.	Part #	Description	Qty.
1	5BP0114981	Support plate, remote gate control; until 08-2008	1
	5BP0014981	Support plate, remote gate control; since 09-2008	1
2	5BP0014982	Lever, remote gate control	1
3	5BP0014983	Handle, flat grooved	1
4	5BP0014477	Bolt HH M10-1.50x60 C8.8 Z P	1
5	5BP0002034	Washer flat Ø10 W	3
6	5BP0014988	Spacer	1
7	5BP0014989	Spring	1
8	5BP0015237	Nut ES M10-1.50 Z TN	1
9	5BP0014990	Cable support	1
10	5BP0014991	Snap ring, outer Ø10	1
11	5BP0014992	Cable; until 08-2008 <sup>17</sup>	1
	5BP0014997	Cable; since 09-2008	1
12	5BP0014590	Bracket, cable support	1
13	5BP0014594	Cable support	1
14	5BP0015255	Bolt HH M12-1.75x30 C8.8 Z F	1
15	5BP0002265	Washer flat Ø12 W	1
16	5BP0013345	Nut ES M12-1.75 Z TK	1
17	5BP0003144	Washer lock Ø8 Z	1
18	5BP0046454	Bolt HH M08-1.25x16 C8.8 Z F	1
	5BP0099850	Remote gate control, complete; SS1036B, SS2036B, SS1067B, SS2067B	-

<sup>17</sup> Part #5BP0014992 no longer available, customer should replace entire accessory.

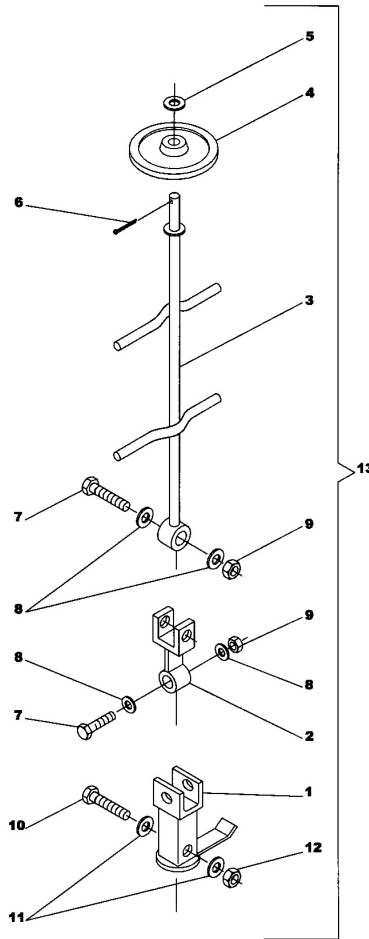

Ref.	Part #	Description	Qty.
1	5BP0014721	Stirrer, tumbling agitator	1
2	5BP0014730	Hitch, tumbling agitator	1
3	5BP0014735	Beam, tumbling agitator	1
4	5BP502005B	Wheel, tumbling agitator	1
5	5BP0002265	Washer flat Ø12 W	1
6	5BP502006B	Cotter pin Ø4x35	1
7	5BP0014477	Bolt HH M10-1.50x60 C8.8 Z P	2
8	5BP0002034	Washer flat Ø10 W	4
9	5BP0014106	Nut ES M10-1.50 Z TK	2
10	5BP0014427	Bolt HH M08-1.25x45 C8.8 Z P	1
11	5BP0015230	Washer flat Ø8 W	2
12	5BP0091384	Nut ES M08-1.25 Z TK	1
13	5BPAA2120	Tumbling agitator, complete; SS1023B (until 02-2011)	-



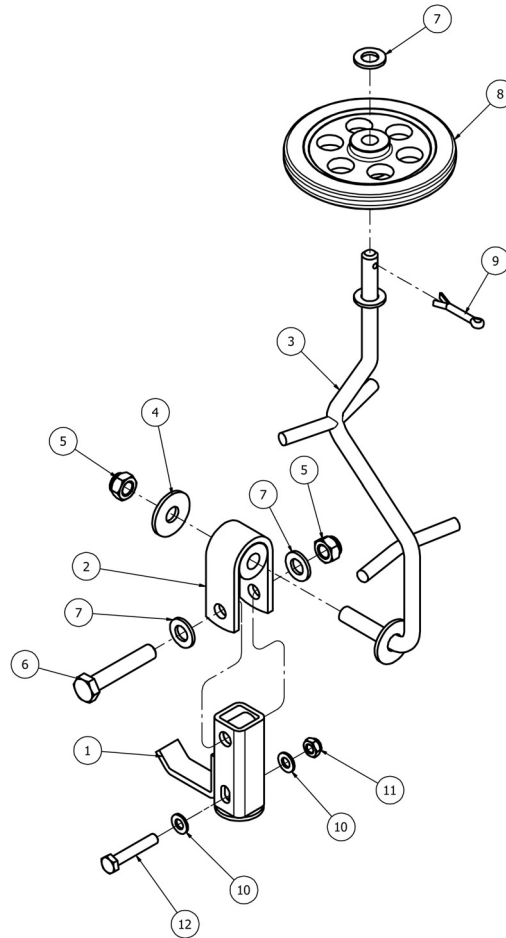

Ref.	Part #	Description	Qty.
1	5BP0014742	Stirrer, tumbling agitator	1
2	5BP0014739	Hitch, tumbling agitator	1
3	5BP0014744	Beam, tumbling agitator	1
4	5BP0076106	Washer fender Ø12 Z	1
5	5BP0030064	Nut PT M12-1.75 C6 TK Z	2
6	5BP0014746	Bolt HH M12-1.75x60 C8.8 ZP	1
7	5BP0002265	Washer flat Ø12 W	3
8	5BP0014488	Wheel, tumbling agitator	1
9	5BP0001174	Cotter pin Ø4x35	1
10	5BP0015230	Washer flat Ø08 W	2
11	5BP0091384	Nut ES M08-1.25 Z TK	1
12	5BP0014427	Bolt HH M08-1.25x45 C8.8 Z P	1
	5BP0099979	Tumbling agitator, complete; SS1023B (since 03/2011)	-

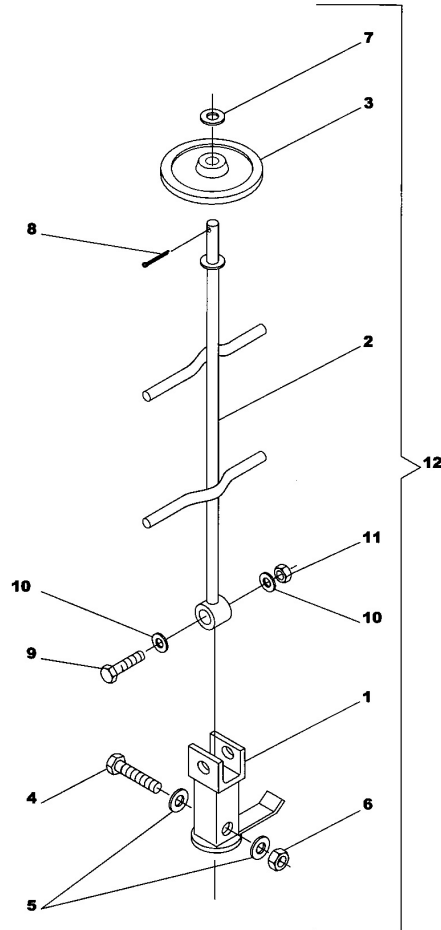

Ref.	Part #	Description	Qty.
1	5BP502019B	Stirrer, tumbling agitator	1
2	5BP502007B	Beam, tumbling agitator	1
3	5BP502005B	Wheel, tumbling agitator	1
4	5BP0014490	Bolt HH M08-1.25x50 C8.8 Z P	1
5	5BP0015230	Washer flat Ø8 W	2
6	5BP0091384	Nut ES M08-1.25 Z TK	1
7	5BP0002265	Washer flat Ø12 W	1
8	5BP502006B	Cotter pin Ø4x35	1
9	5BP0014477	Bolt HH M10-1.50x60 C8.8 Z P	1
10	5BP0002034	Washer flat Ø10 W	2
11	5BP0014106	Nut ES M10-1.50 Z TK	1
12	5BPAA3120	Tumbling agitator, complete; SS1036B, SS2036B, SS1067B, SS2067B (until 02/2011)	-

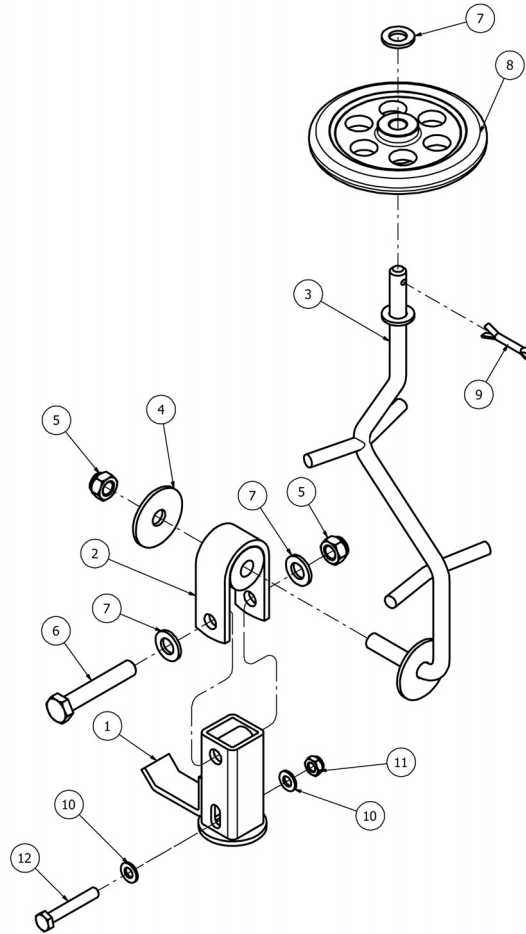

Ref.	Part #	Description	Qty.
1	5BP0014485	Stirrer, tumbling agitator	1
2	5BP0014478	Hitch, tumbling agitator	1
3	5BP0014470	Beam, tumbling agitator	1
4	5BP0057273	Washer fender Ø12 Z	1
5	5BP0030064	Nut PT M12-1.75 C6 TK Z	2
6	5BP0034265	Bolt HH M12-1.75x65 C8.8 Z P	1
7	5BP0002265	Washer flat Ø12 W	3
8	5BP0014488	Wheel, tumbling agitator	1
9	5BP0001174	Cotter pin Ø4x35	1
10	5BP0015230	Washer flat Ø08 W	2
11	5BP0091384	Nut ES M08-1.25 Z TK	1
12	5BP0014490	Bolt HH M08-1.25x50 C8.8 Z P	1
	5BP0099978	Tumbling agitator, complete;SS1036B, SS2036B, SS1067B, SS2067B (since 03/2011)	-

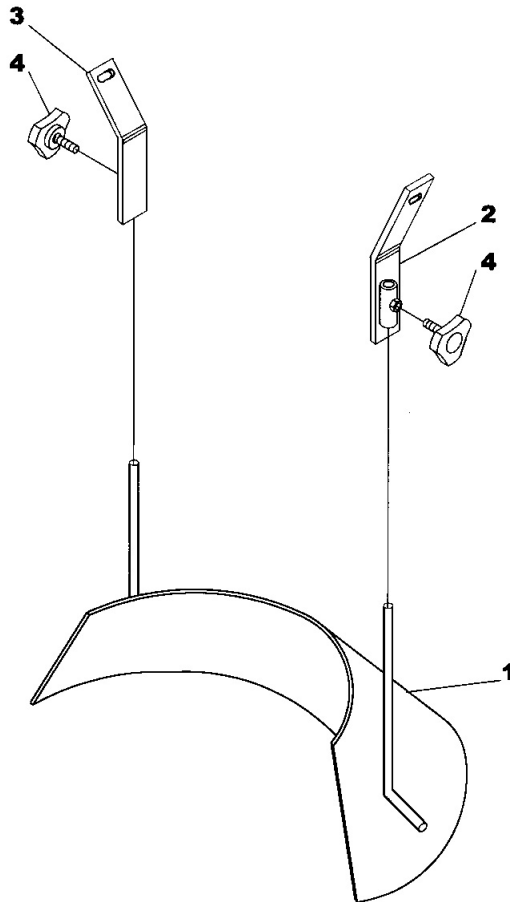

Ref.	Part #	Description	Qty.
1	5BP501653B	Deflector shield	1
2	5BP0214680	Deflector connection, left	1
3	5BP0114680	Deflector connection, right	1
4	5BP501631B	Adjustment knob M6x16	2
	5BP0099524	Deflector, complete; SS1023B, SS1036B, SS2036B	-

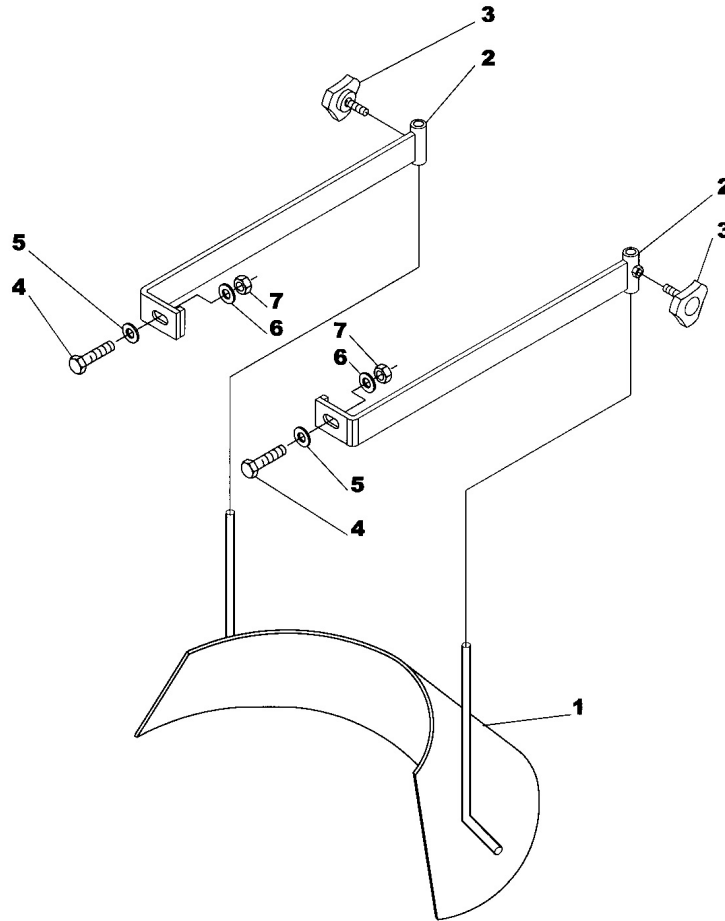

Ref.	Part #	Description	Qty.
1	5BP0014501	Deflector shield	1
2	5BP0014505	Deflector connection	2
3	5BP501589B	Adjustment knob M8x15	2
4	5BP0046543	Bolt HH M08-1.25x30 C8.8 Z F	2
5	5BP0014514	Washer fender Ø8 Z	2
6	5BP0015230	Washer flat Ø8 W	2
7	5BP0091384	Nut ES M08-1.25 Z TK	2
	5BP0099638	Deflector, complete; SS1067B, SS2067B	-

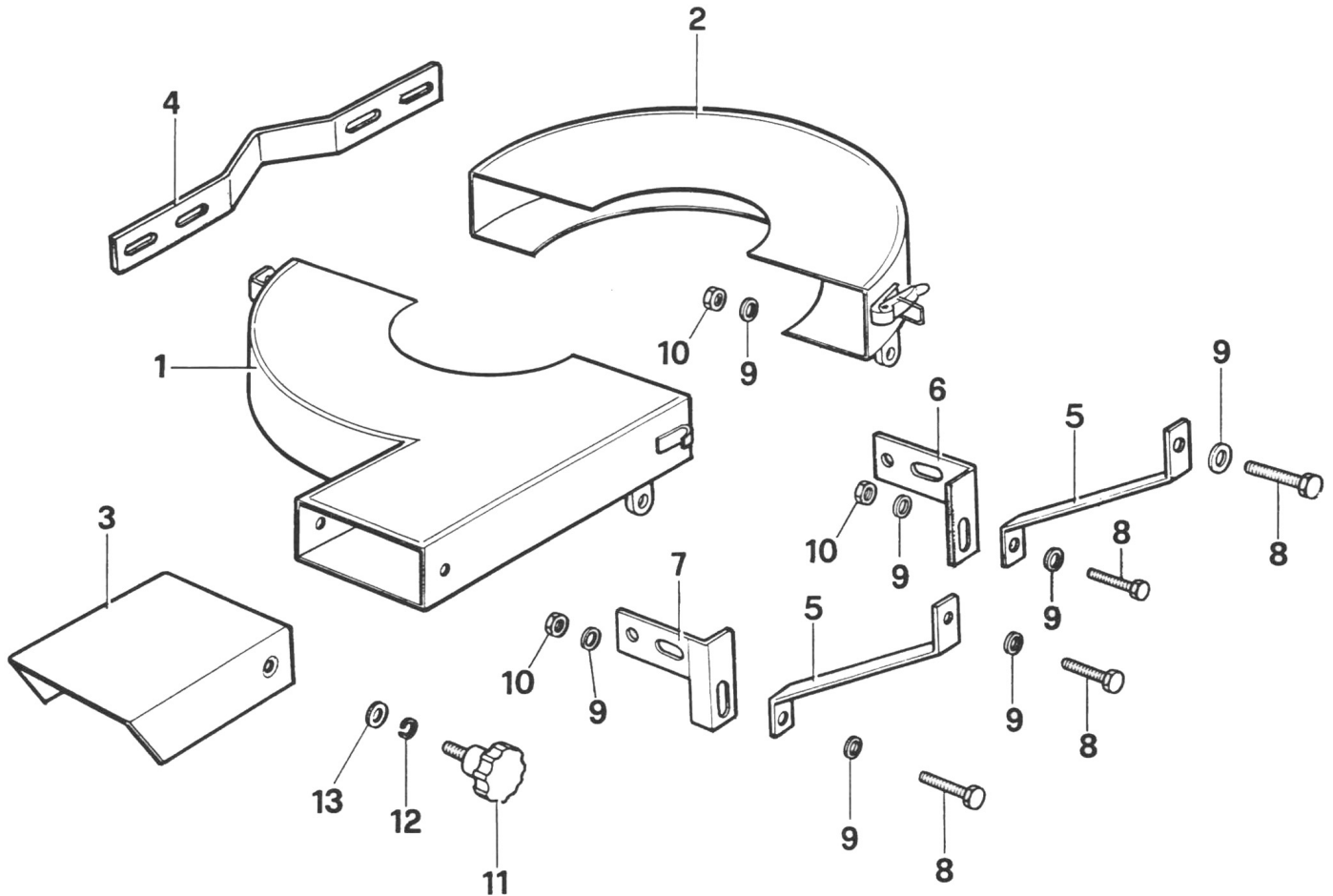

Ref.	Part #	Description	Qty.
1	5BP503701B	Half conveyor, left	1
2	5BP503702B	Half conveyor, right	1
3	5BP503703B	Baffle plate	1
4	5BP503704B	Conveyor attachment	1
5	5BP503705B	Conveyor bracket	2
6	5BP503706B	Bracket attachment plate, right	1
7	5BP503707B	Bracket attachment plate, left	1
8	5BP0091446	Bolt HH M08-1.25x25 C8.8 Z F	8
9	5BP0015230	Washer flat Ø8 W	16
10	5BP0091384	Nut ES M08-1.25 Z TK	8
11	5BP501589B	Adjustment knob M8x15	2
12	5BP0003144	Washer lock Ø8 Z	2
13	5BP0002034	Washer flat Ø10 W	2
	5BPAA4120	Siderow discharge, complete; SS1067B, SS2067B	-

**Note:** Serial #'s with the XF prefix are subsequent to serial numbers with the BC prefix. For example: A reference to "serial # BC... 739197 & above" will also include all serial numbers with an XF prefix.

## **Use only original spare parts**

*All rights reserved. It is unlawful to copy, reprint or use any of the information or details in this manual without the expressed written permission of the Company. Technical information provided in this manual is approximate, the Company reserves the right to modify or improve the models shown for technical or commercial purposes. Pictures in this manual do not necessarily show the machine as delivered.*



Manual 5BP960376B  
Date 05/19/2011



## Free Manuals Download Website

<http://myh66.com>

<http://usermanuals.us>

<http://www.somanuals.com>

<http://www.4manuals.cc>

<http://www.manual-lib.com>

<http://www.404manual.com>

<http://www.luxmanual.com>

<http://aubethermostatmanual.com>

Golf course search by state

<http://golfingnear.com>

Email search by domain

<http://emailbydomain.com>

Auto manuals search

<http://auto.somanuals.com>

TV manuals search

<http://tv.somanuals.com>