

O P E R A T O R ' S M A N U A L

ROTARY TILLERS

RT 1142

RT 1157

RT 1265

RT 1149

RT 1165

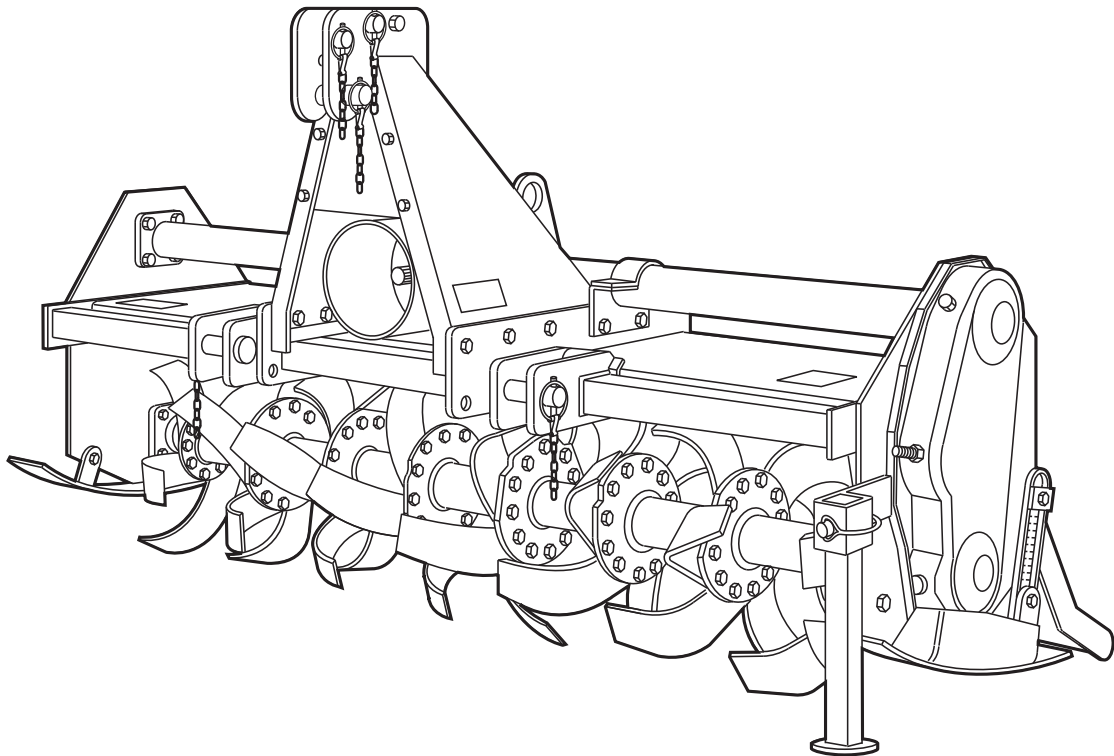

FRONTIER
EQUIPMENT

Cod. F07010181 / Rev. 05 (2011-09)

TABLE OF CONTENTS

Technical specification		Tilling tips	20
Technical specification	4	During tilling	20
Technical specification - Hitch	6	Replacement parts	20
Safety signs		Service Machine Safely	
Safety-Alert simbol	7	Practice safe maintenance	21
Identification machine	7	Wear appropriate clothing	21
Machine safety labels	7	Stay clear of rotating drivelines	21
Machine safety labels and positions		Service lubrication	
Machine safety labels and positions.....	8	Service lubrication.....	22
Preparing the vehicle		Every 8 work hours.....	22
Preparing the tractor	10	Every 50 work hours.....	22
Park vehicle safety.....	10	Every 400 work hours.....	22
Stay clear of rotating drivelines	10	Every 1000 work hours.....	22
Installing		Greasing and lubricant points.....	23
Installing tiller on tractor.....	10	Lubricants.....	23
PTO shaft	12	Service	
PTO shaft with shear pin	13	Chain stretcher	24
PTO shaft with clutch	13	Service intervals.....	24
Quick Coupler (optional).....	14	Bolts tightening torques.....	24
Park vehicle safety.....	14	Replacing tines.....	24
Stay clear of rotating drivelines	14	Tines.....	25
Removing		Troubleshooting	
Removing tiller.....	15	Using troubleshooting chart	26
Removing tiller with Quick Coupler.....	15	Storing machine	
Operating		Storing tiller	27
Operate safely	16	Removing tiller from storage	27
Wear appropriate clothing	17	Assembly / Spare parts	
Stay clear of rotating driveline	17	RT 1142-1149	28
Raising parking stand.....	17	RT 1157-1165.....	30
Lowering parking stand	17	RT 1265	32
Leveling attachments (side-to-side).....	17	Installing driveline on tiller	34
Leveling tiller (front-to-rear)	18	Spare parts.....	34
Adjusting skid shoes	18		
Adjusting levelling board.....	18		
Adjustable offset.....	19		

TO THE DEALER:

Assembly and proper installation of this product is the responsibility of the Frontier dealer. Read manual instruction and safety rules. Make sure all items on the Dealer's Pre-Delivery Check List in the Operator's Manual are completed before releasing equipment to the owner.

The dealer must complete the Warranty Registration, located on the Frontier website. **Warranty claims will be denied if the Warranty Registration has not been completed.**

TO THE OWNER:

Read this manual before operating your frontier equipment. The information presented will prepare you to do a better and a safer job. Keep this manual handy for ready reference. Require all operators to read this manual carefully and become acquainted with all the adjustment and operating procedures before attempting to operate. Replacement manuals can be obtained from your selling dealer.

The equipment you have purchased has been carefully engineered and manufactured to provide dependable and satisfactory use. Like all mechanical products, it will require cleaning and upkeep. Lubricate the unit as specified. Observe all safety information in this manual and safety decals on the equipment.

For service, your authorized Frontier dealer has trained mechanics, genuine Frontier service parts, and the necessary tools and equipment to handle all your needs.

Use only genuine Frontier service parts. Substitute parts will void the warranty and may not meet standards required for safe and satisfactory operation. Record the model number and serial number of your equipment in the spaces provided:

Model: _____

Date of Purchase _____

Serial Number: (see Safety Decal section for location) _____

Provide this information to your dealer to obtain correct repair parts.

Throughout this manual, the term **IMPORTANT** is used to indicate that failure to observe can cause damage to equipment. The terms **CAUTION**, **WARNING** and **DANGER** are used in conjunction with the Safety-Alert Symbol, (a triangle with an exclamation mark), to indicate the degree of hazard for items of personal safety.



This Safety-Alert Symbol indicates a hazard and means **ATTENTION! BECOME ALERT! YOUR SAFETY IS INVOLVED!**



Indicates an imminently hazardous situation that, if not avoided, will result in death or serious injury.



WARNING

Indicates a potentially hazardous situation that, if not avoided, could result in death or serious injury, and includes hazards that are exposed when guards are removed.



CAUTION

Indicates a potentially hazardous situation that, if not avoided, may result in minor or moderate injury.

IMPORTANT

Indicates that a failure to observe can cause damage to equipment.

NOTE

Indicates helpful information.

Cod. F07010181 / Rev. 05 (2011-09)

TECHNICAL SPECIFICATIONS

RT 1142 - 1149
(Adjustable offset)

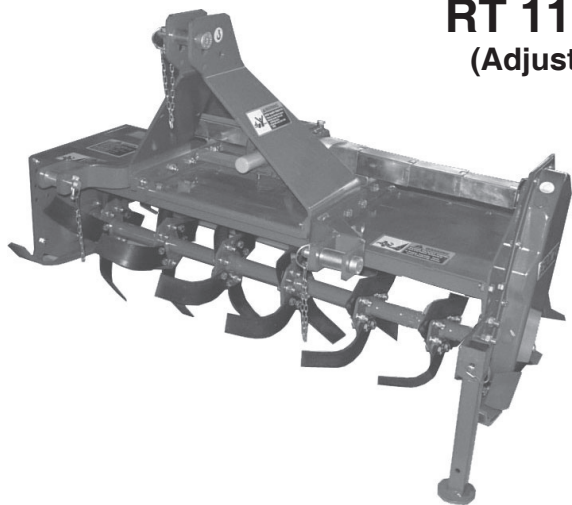

RT 1157 - 1165
(Adjustable offset)

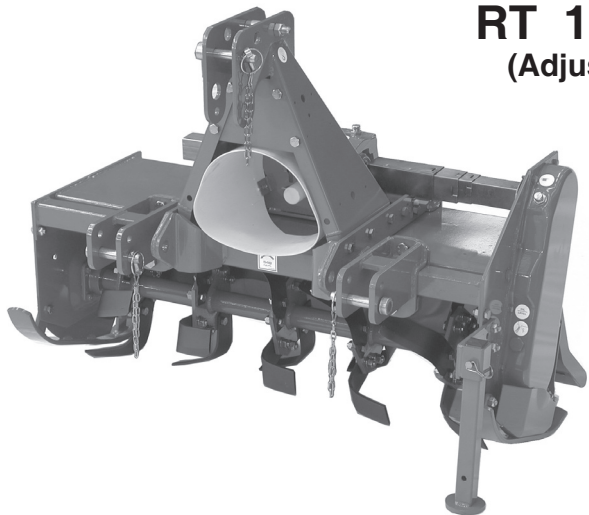

RT 1265

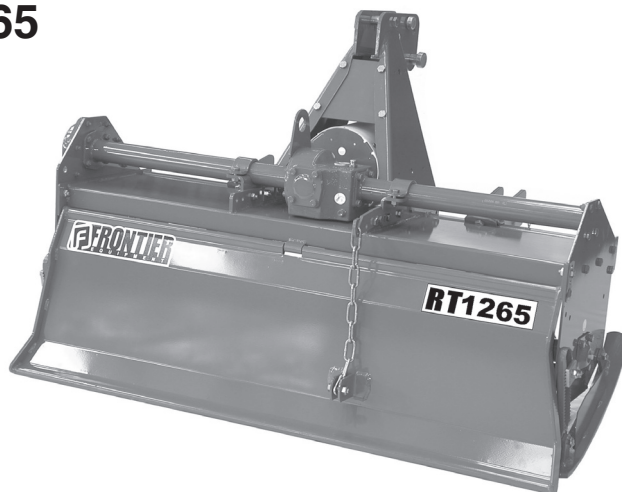
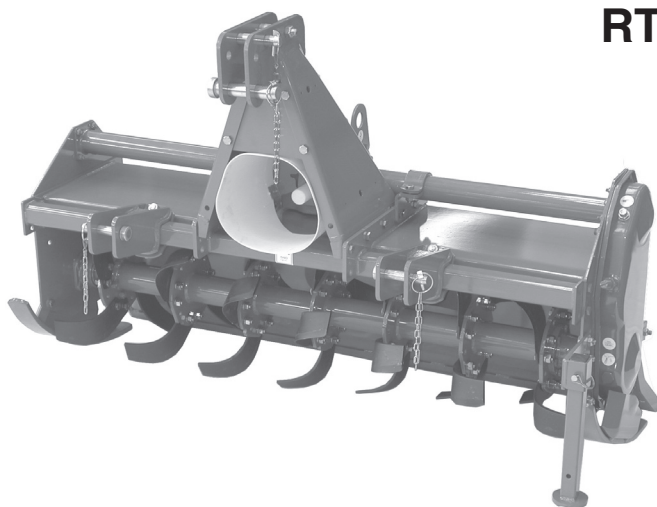

TECHNICAL SPECIFICATIONS

RT 1142 - 1149

<i>Model</i>	<i>Work/width inches</i>	<i>Tractor HP min</i>	<i>Tractor HP max</i>	<i>Weight lbs.</i>	<i>Side Drive</i>	<i>PTO shaft</i>	<i>Speeds gear box</i>	<i>Input speed</i>	<i>Hitch</i>	<i>Max offset</i>	<i>Tines STD</i>	<i>Rotor blades</i>	<i>Rotor flanges</i>
RT 1142	42	10-20	25	293	Chain ASA 80	Shear Pin	Single	540	Cat. "I" Quick coupler	3.9"	"C"	4	5
RT 1149	49	10-20	25	323	Chain ASA 80	Radial Slip Clutch	Single	540	Cat. "I" Quick coupler	7.9"	"C"	4	6

RT 1157 - 1165

<i>Model</i>	<i>Work/width inches</i>	<i>Tractor HP min</i>	<i>Tractor HP max</i>	<i>Weight lbs.</i>	<i>Side Drive</i>	<i>PTO shaft</i>	<i>Speeds gear box</i>	<i>Input speed</i>	<i>Hitch</i>	<i>Max offset</i>	<i>Tines STD</i>	<i>Rotor blades</i>	<i>Rotor flanges</i>
RT 1157	57	25	40	480	Chain ASA 80	Slip Clutch	Single	540	Cat. "I"-"II" Quick coupler	15.5"	"C"	6	7
RT 1165	65	30	40	534	Chain ASA 80	Slip Clutch	Single	540	Cat. "I"-"II" Quick coupler	18.1"	"C"	6	8

RT 1265

<i>Model</i>	<i>Work/width inches</i>	<i>Tractor HP min</i>	<i>Tractor HP max</i>	<i>Weight lbs.</i>	<i>Side Drive</i>	<i>PTO shaft</i>	<i>Speeds gear box</i>	<i>Input speed</i>	<i>Hitch</i>	<i>Tines STD</i>	<i>Rotor blades</i>	<i>Rotor flanges</i>
RT 1265	65	30-50	60	616	ASA 100	Chain Slip Clutch	Single	540	Quick coupler	Cat. "I"-"II" "C"	6	8

TECHNICAL SPECIFICATIONS - HITCH

RT 1142 and 1149: Cat. «I» Standard
RT 1142 and 1149: Cat. «I» Quick Coupler

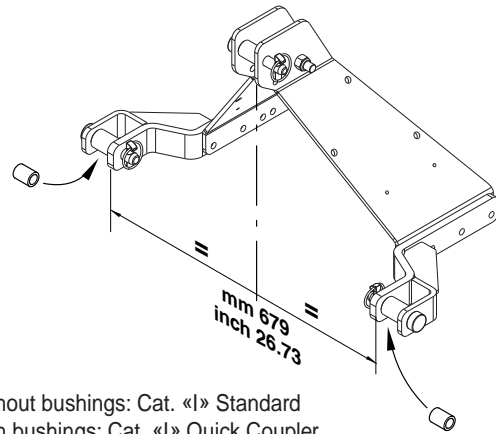

Without bushings: Cat. «I» Standard
 With bushings: Cat. «I» Quick Coupler

RT 1157 and 1165 : Cat. «I» and «II» Standard

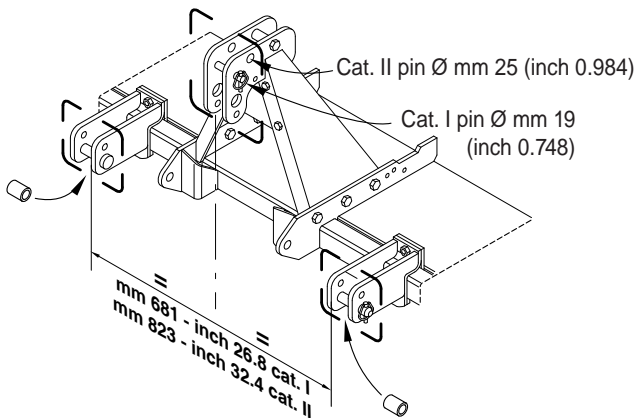

Without bushings: Cat. «I» Standard
 With bushings: Cat. «II» Standard

RT 1157 and 1165 : Cat. «I» and «II» Quick Coupler

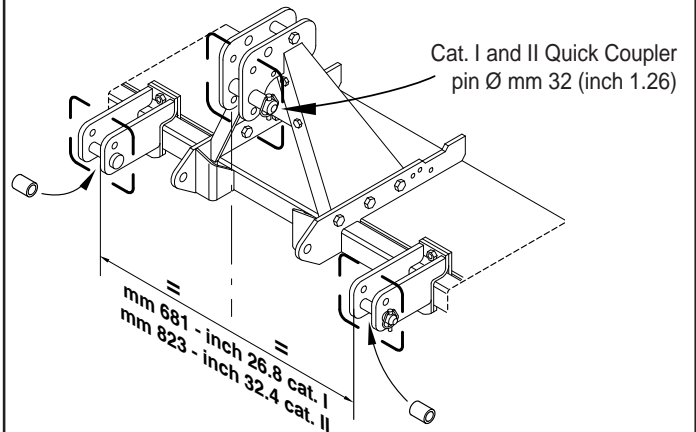

With bushings

RT 1265: Cat. «I» and «II» Quick Coupler

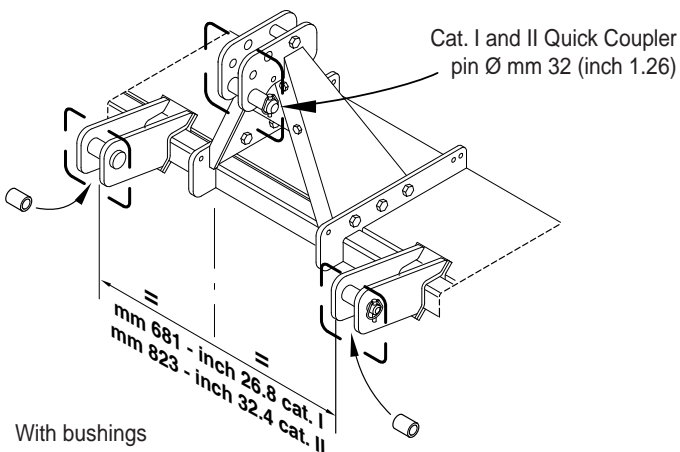

With bushings

RT 1265: Cat. «I» and «II» Standard

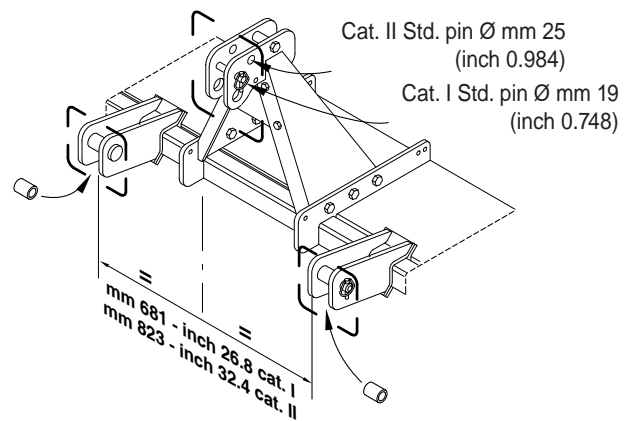

Without bushings: Cat. I Standard
 With bushings: Cat. II Standard

SAFETY SIGNS

Safety-alert symbol

Read and recognize safety information.

Be alert to the potential for personal injury when you see this safety-alert symbol.



On your machine safety labels, the words DANGER, WARNING, and CAUTION are used with safety-alert symbol.

DANGER identifies the most serious hazards. In this manual, the word CAUTION and this symbol call attention to safety messages.

Identification machine

Identification plate machine

Machine safety labels

1) WARNING: AVOID INJURY FROM ROTATING KNIVES:

- Keep hands, feet and clothing away.

2) WARNING: AVOID INJURY FROM PTO:

- Keep all shields in place. Keep hands, feet and clothing away.
- Operate only with 540 RPM.

3) CAUTION: AVOID INJURY

- Read Operator's Manual
- Ballast power unit per operator's manual
- Know location and function of controls
- Keep all shields in place
- Stay clear of power driven parts
- Never carry riders
- Keep people and pets a safe distance away from machine

BEFORE DISMOUNTING OR SERVICING

- Shut off engine and remove key
- Lock brake for park
- Lower or block up machine

4) DANGER: ROTATING DRIVELINE - CONTACT CAN CAUSE DEATH - KEEP AWAY! - DO NOT OPERATE WITHOUT:

- All driveline, tractor and equipment shields in place
- Drivelines securely attached at both ends
- Drivelines shields that turn freely on driveline.

5) DANGER: SHIELD MISSING DO NOT OPERATE

Picture Note: Separate telescoping driveshaft members to locate safety label. Label attached to outer profile tube.



MACHINE SAFETY LABELS AND POSITIONS

RT 1142 - 1149

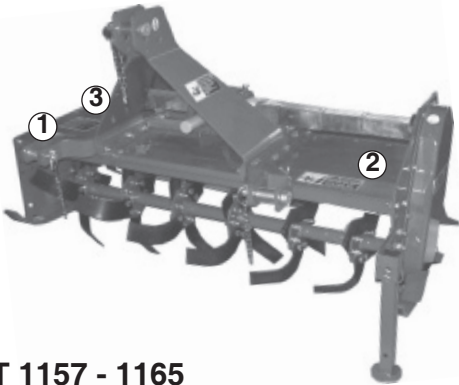

1

RT 1157 - 1165

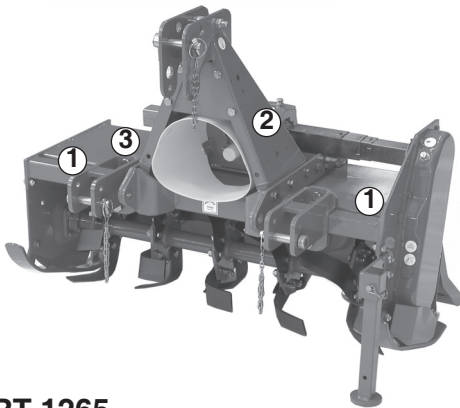

2

RT 1265

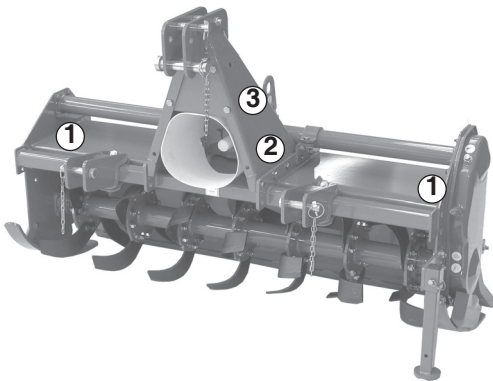

3

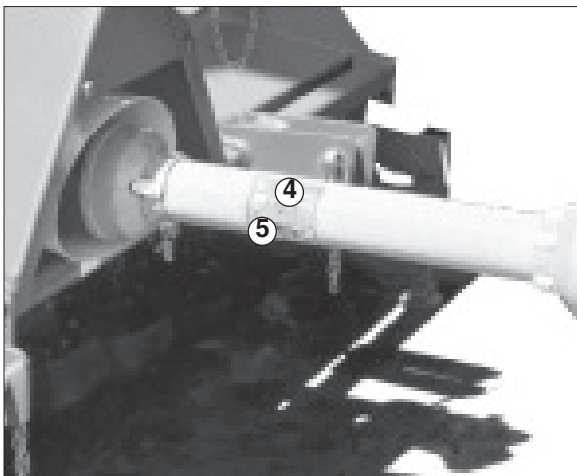

4



5

MACHINE SAFETY LABELS AND POSITIONS

RT 1142 - 1149

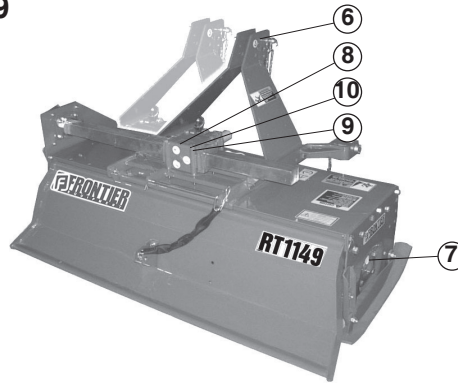
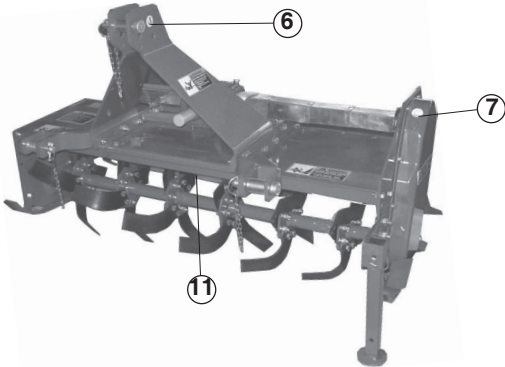

6



7

RT 1157 - 1165

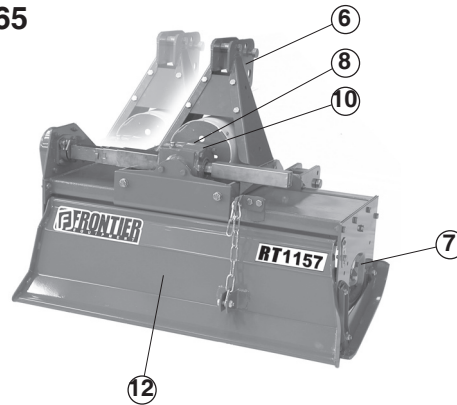
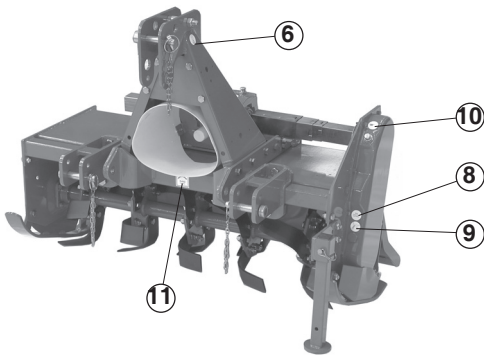

8



9

RT 1265

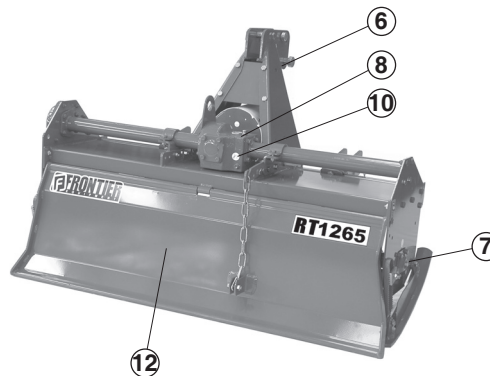
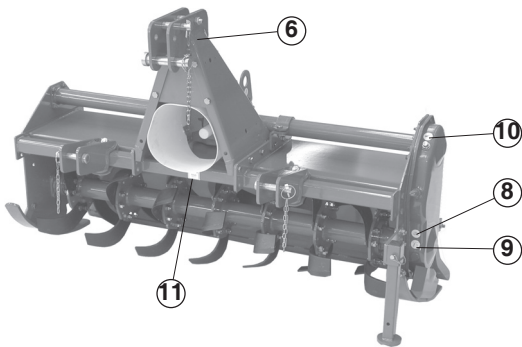

10



11

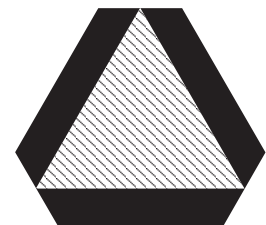

12

- 6) Coupling point for lifting (indicating the maximum capacity)
- 7) Greasing point
- 8) Oil level plug
- 9) Oil drain plug
- 10) Oil fill plug
- 11) Number of revolutions of power takeoff
- 12) Warning, slow machine (only for model: 1157 and 1265)

PREPARING THE VEHICLE

Preparing the tractor



CAUTION: Avoid injury. Proper ballasting is required for safe operation of your tiller

IMPORTANT: Refer to the tractor operator manual for proper ballasting information and tire inflation

- A 540 rpm PTO
- Refer to the tractor operator manual for correct ballasting and tire pressure, depending on installed equipment.

Park vehicle safety

- Stop vehicle on a level surface, not on a slope.
- Disengage PTO.
- Engage the park brake.
- STOP the engine.
- Remove the key.
- Before you leave the operator's seat, wait for engine and all moving parts to STOP.

Stay clear of rotating drivelines

Entanglement in rotating driveline can cause serious injury or death:

- Wear close fitting clothing.
- STOP the engine and be sure PTO driveline is stopped before getting near it.

Installing tiller on tractor

1. Back tractor into position and align draft links (A) with draft link brackets on tiller using tractor rockshaft control.

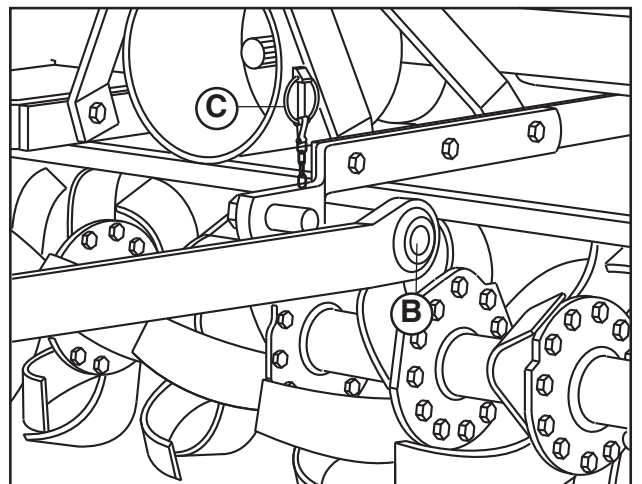
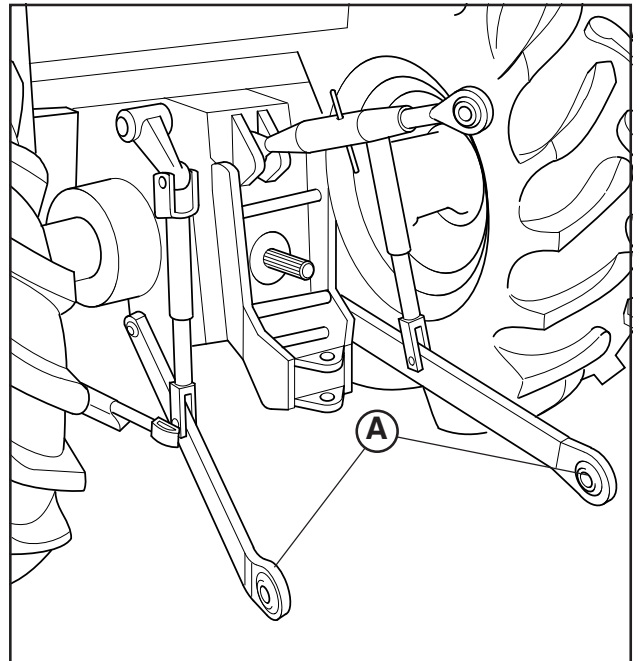

CAUTION: Before you work around hitch:

- STOP engine.
- LOCK park brake.
- FIRMLY block tiller on horizontal surface.

Locate driller pin in holes (B).

RT 1142-1149 model.

2. Fasten each draft link to draft link brackets with drilled pins and quiklock pins (C).

INSTALLING

Locate driller pin in lower lift brackets holes (B).

RT 1157-1165 model.

2. Fasten each draft link to draft link brackets with drilled pins and quiklock pins (C).

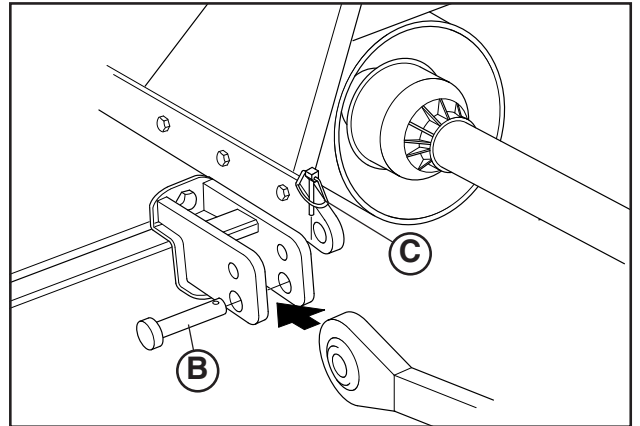

Locate driller pin in holes (B).

RT 1265 model.

2. Fasten each draft link to draft link brackets with drilled pins and quiklock pins (C).

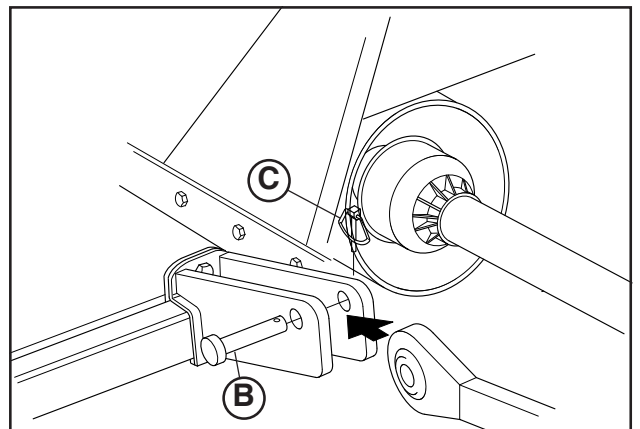

Locate driller pin in top holes (D)

RT 1142-1149 model.

3. Install center link (F) on tiller and fasten with drilled pin and quiklock pin (E).

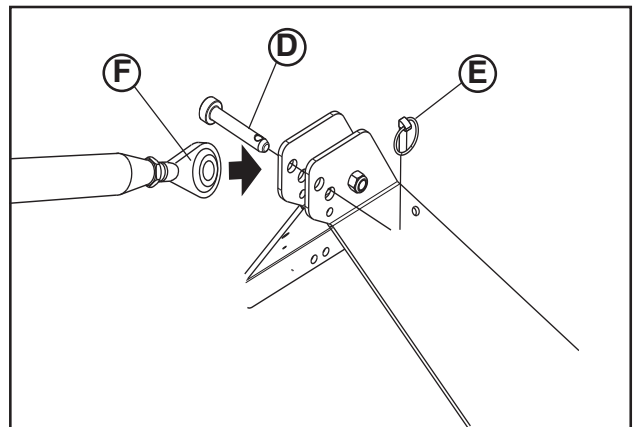

Locate driller pin in top holes (D)

RT 1157-1165 and 1265 model.

3. Install center link (F) on tiller and fasten with drilled pin and quiklock pin (E).

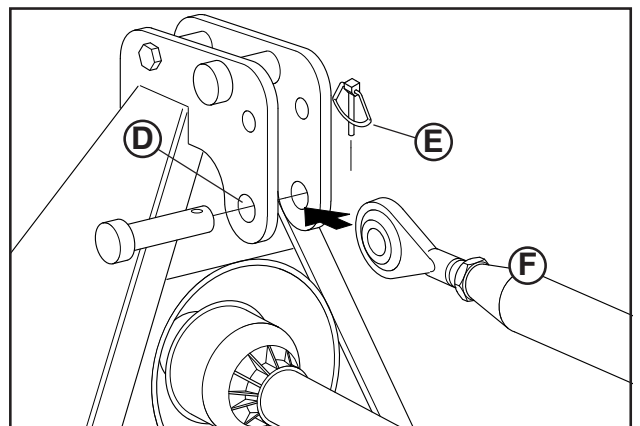

INSTALLING

4. Install PTO shaft to tractor.

IMPORTANT: Tiller MUST BE level front to rear.

- Engage the cardan shaft and check that it is perfectly locked on the tractor PTO (G). Check that the guard (H) is free to turn and fix it with the relative latch.
5. Raise tiller.
 6. Remove spring locking pin (K) from parking stand.
 7. Slide parking stand (I) all the way up on tiller bracket (J).
 8. Fasten with spring locking pin (K).
 9. Level tiller (See Leveling Tiller in the Operating Tiller section).
 10. Adjust sway chains on tractor lower draft arms to minimize side way.

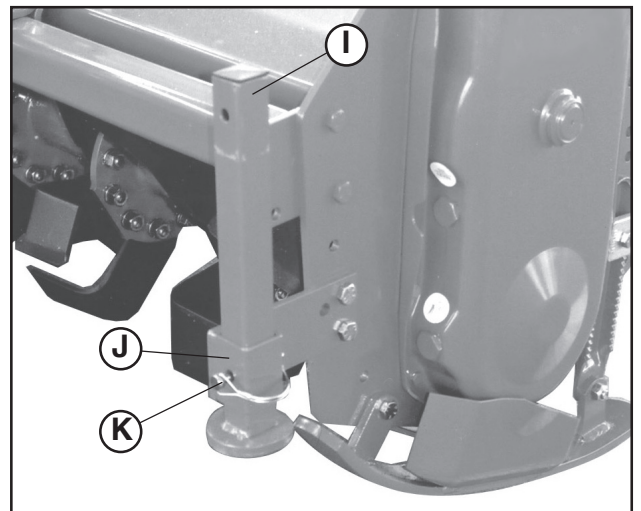
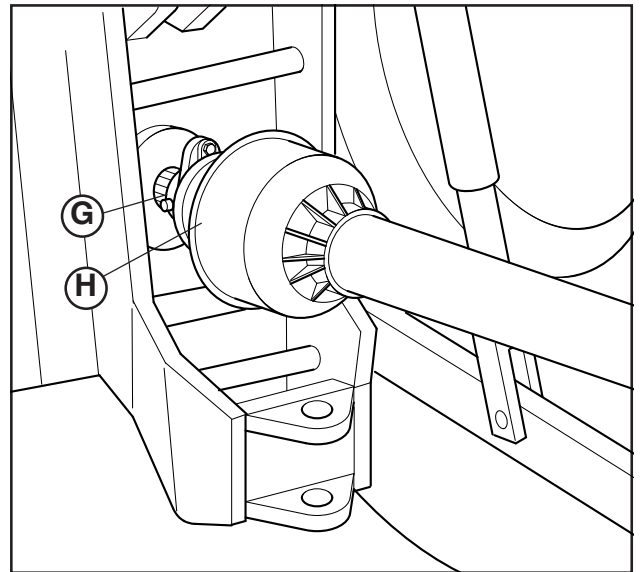

PTO shaft

The PTO shaft, supplied with the machine, is of standard length.

Therefore it might be necessary to adapt the PTO shaft. In that case, before doing anything, consult the Manufacturer for the eventual adaptation.

When the PTO shaft is fully extended, the two tubes must overlap by at least 15 cm (A). When fully inserted, the minimum play must be 4 cm (B).



CAUTION: If the implement is used on another tractor, always check that the guards completely cover the rotating parts of the PTO shaft.

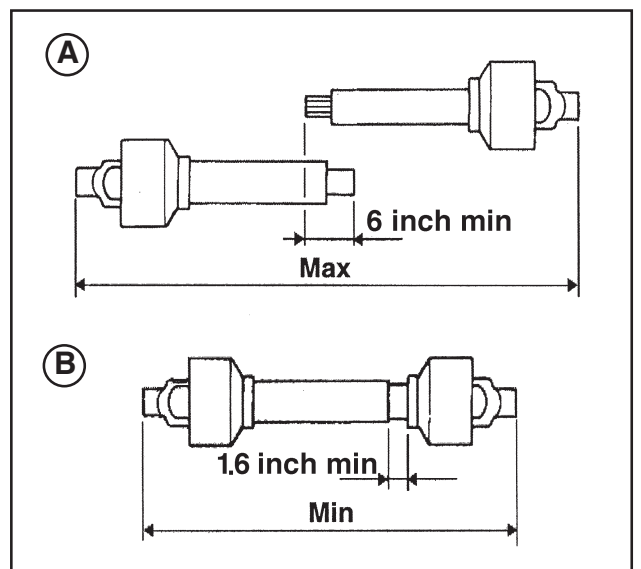

INSTALLING

PTO shaft with shear pin (1142 model)

The shear pin, inserted in the PTO shaft, is equipped with a safety bolt (A) that is set for an average force. Whenever unduly resistant obstacles cause the bolt to shear, it must be replaced by a new bolt.

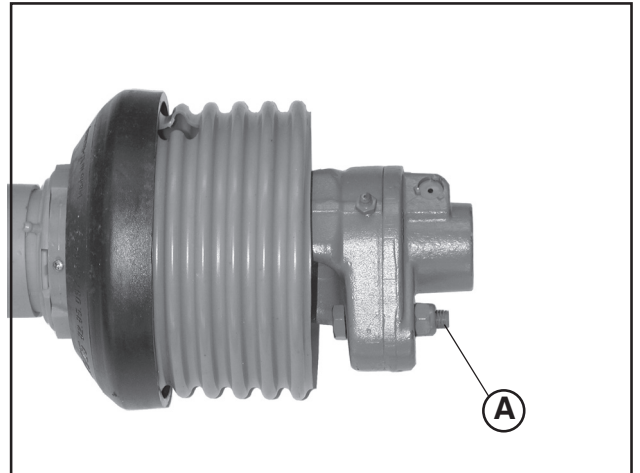

PTO shaft with clutch (1149-1157-1165-1265 model)

The PTO shaft can be equipped with safety clutch to protect the transmission components of the machine from stress and/or excessive overloads.

The tilt of the PTO shaft must not exceed 10 degrees.

The clutch is already pre-adjusted for average stress. If it slips too easily (and overheats), it will be necessary to evenly tighten all the nuts (D) that retain the spring.

The clutch disks must be changed if the clutch still slips after all the nuts have been tightened.

If the clutch does not slip, evenly unscrew all the spring fixing nuts (D). Unscrew one turn at a time and check the clutch after having worked about 300 meters. Repeat the operation if necessary, remembering to unscrew one turn at a time. If the clutch maintains a temperature of about 40-50°C (104-122°F) degrees during work, this means that it has been correctly regulated.

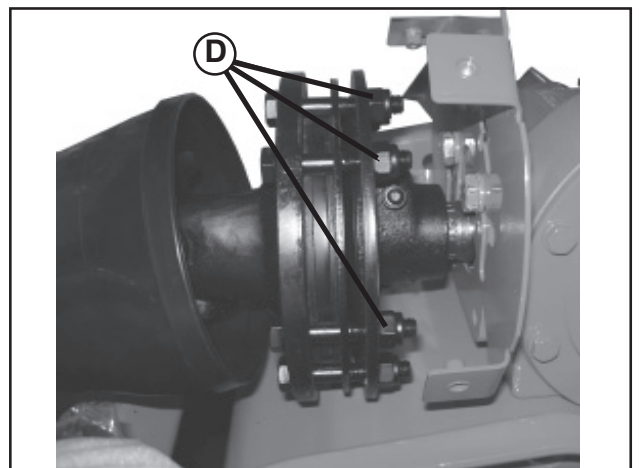
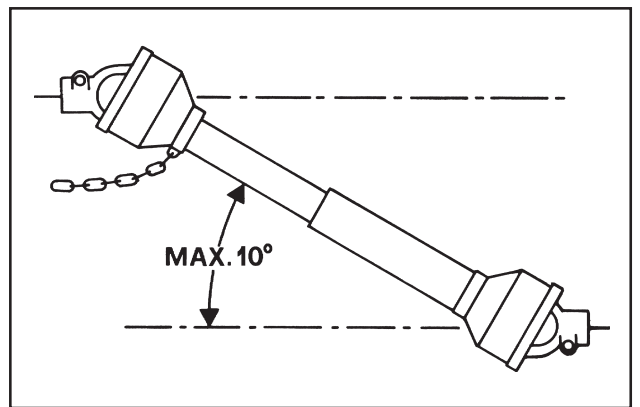

IMPORTANT: Never fully tighten the nuts. This would void the function of the springs and, subsequently, of the clutch, thus damaging the transmission components.

NOTE: This inspection must be performed at the beginning of each new season.

INSTALLING

Quick Coupler (optional)

- 1) Install hitch Quick Coupler (A) on the tractor (see tractor operator manual).
- 2) Stop vehicle on a level surface, not on a slope, then move the tractor back until the Quick Coupler (A) is range with the (B) and (C) hitch points.
- 3) Raise the Quick Coupler (A) and make sure that tiller's hitch is in the right position (E).

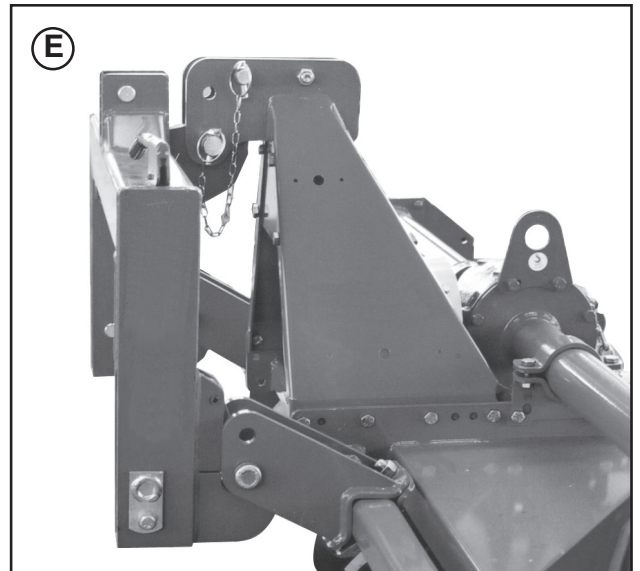
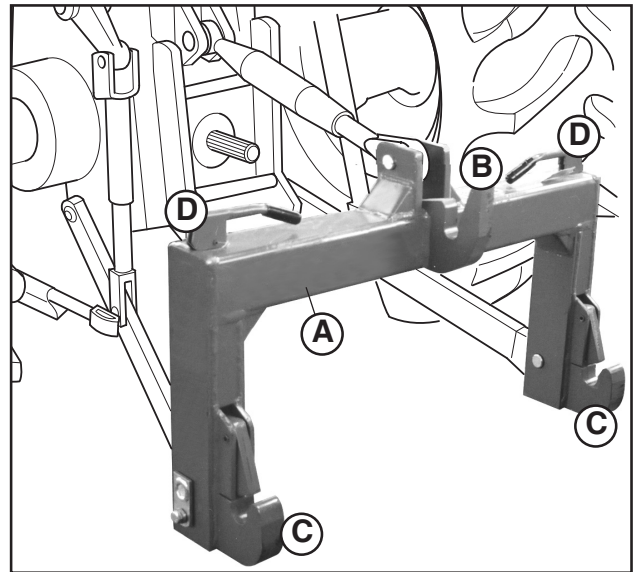

CAUTION: Before you work around hitch:

- STOP engine.
- LOCK park brake.
- FIRMLY block tiller on horizontal surface..

Park vehicle safely

- Stop vehicle on a level surface, not on a slope.
- Disengage PTO.
- Engage the park brake.
- STOP the engine.
- Remove the key.
- Before you leave the operator's seat, wait for engine and all moving parts to STOP.

Stay clear of rotating drivelines

Entanglement in rotating driveline can cause serious injury or death:

- Wear close fitting clothing.
- STOP the engine and be sure PTO driveline is stopped before getting near it.



REMOVING

Removing tiller

1. Raise tiller.
2. Put parking stand (A) in the DOWN position:
Install spring locking pin (C) in order to secure parking stand (A) to the tiller bracket (B).
3. Lower tiller to the ground.



CAUTION: Before you work around hitch:

- STOP engine.
- LOCK park brake.
- FIRMLY block tiller on horizontal surface.

4. Disconnect driveline from tractor by pulling back on coupler to release it from the LOCKED position.
5. Remove quik-lock pin (D) and drilled pin (E) from center link (F).

NOTE: Put quik-lock pins and driller pins back into brackets on tiller for storage.

6. Remove draft links (J) from draft link brackets (G) by removing quiklock pins (H) and drilled pins (I).

NOTE: Put quik-lock pins and driller pins back into brackets on tiller for storage.

7. Drive tractor forward slowly.

Removing tiller with Quick Coupler

1. Raise tiller.
2. Put parking stand (A) in the DOWN position:
Install spring locking pin (C) in order to secure parking stand (A) to the tiller bracket (B).
3. Lower tiller to the ground.
4. Raise the two Quick Coupler levers (D) to unlock tiller (*Quick Coupler figure, page 14*).
5. Lower Quick Coupler until free from the tiller.

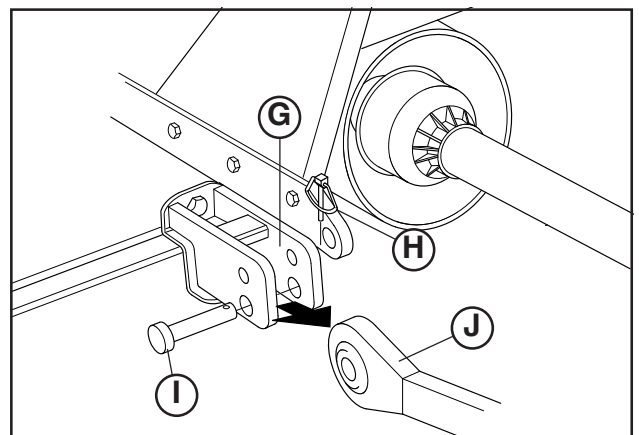
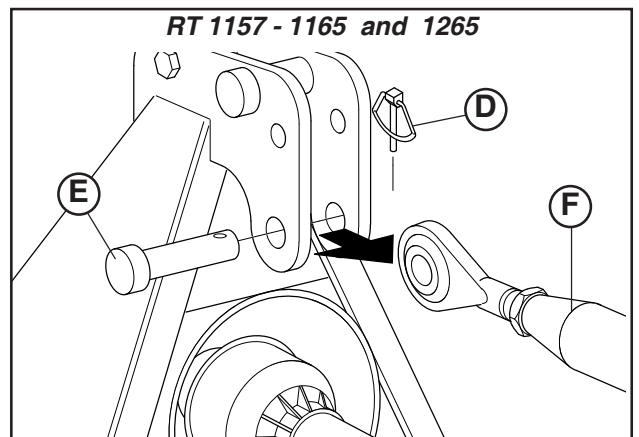
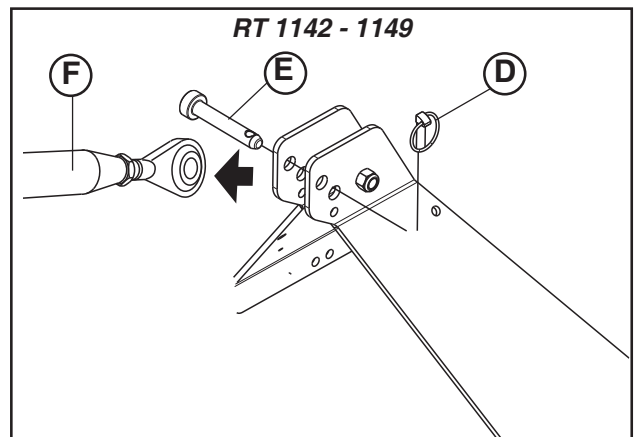
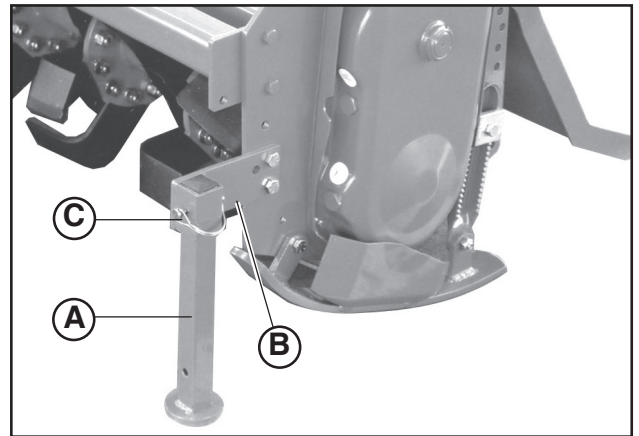

OPERATING

Operate safely

- Protect your hands when you inspect or unplug the tiller. You may need gloves or tools, such as a screwdriver or scraper. Be sure hardware is tight. Repair or replace damaged, badly worn, or missing parts. Be sure guards and shields are in good condition and fastened in place. Make any necessary adjustments before you operate.

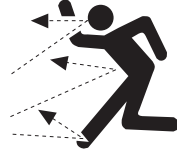

- Clear work area of objects that you do not want tilled into the ground or that might damage the tiller. Consider the tilling area and set up a safe tilling pattern. Do not till under condition in which traction or stability is doubtful. Keep people and pets out of the work area. Stop machine if anyone enters the area.
- If you hit an object, stop the machine and inspect it. Make repairs before you operate. Keep machine properly maintained and in good working order.
- DO NOT leave machine unattended when it is running.
- Only operate during daylight or with good artificial light.
- DO NOT let anyone, ESPECIALLY CHILDREN, ride on machine or vehicle. Riders are subject to injury such as being thrown off. Riders may also obstruct the operator's view, resulting in the machine being operated in an unsafe manner.
- DO NOT let children or an untrained person operate machine.
- DO NOT wear radio or music headphones while operating the machine. Safe operation requires your full attention.

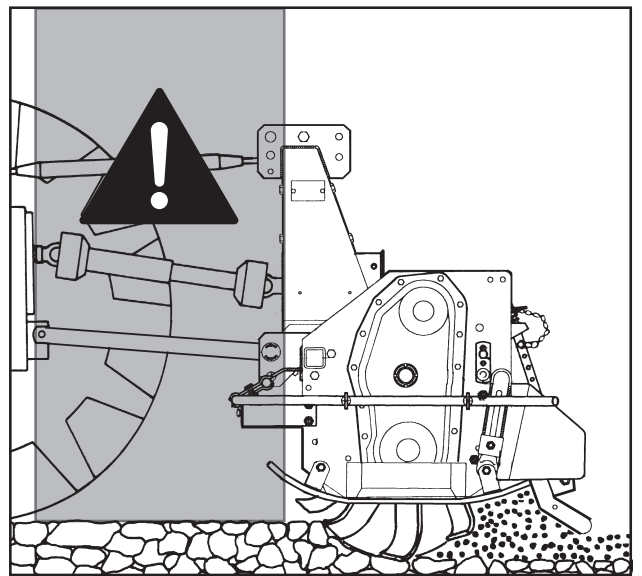

It is absolutely forbidden to stand between the tractor and the implement when maneuvering the lift control from the outside.

OPERATING

Wear appropriate clothing

- Wear close fitting clothing and safety equipment appropriate for the job.
- Loud noise can cause impairment or loss of hearing, wear a suitable protective device such as ear-plugs.



Stay clear of rotating drivelines

Entanglement in rotating driveline can cause serious injury or death:

- Wear close fitting clothing
- Stop the engine and be sure PTO drivelines is stopped before getting near it.



CAUTION: Before you work around hitch:

- **STOP** engine.
- **LOCK** park brake.
- **FIRMLY** block tiller on horizontal surface.

Raising parking stand

1. Remove spring locking pin (C).
2. Slide parking stand (A) all the way up on tiller bracket (B).
3. Fasten with spring locking pin (C).

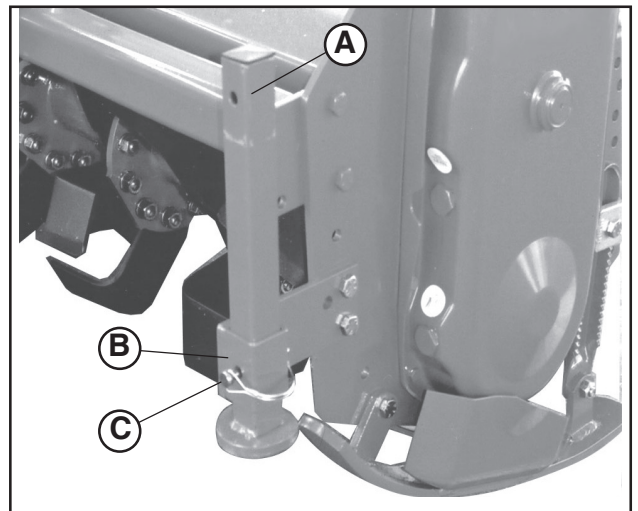

Lowering parking stand

1. Remove spring locking pin (C).
2. Slide parking stand (A) and put down on tiller bracket (B).
3. Install spring locking pin in order to secure parking stand to the tiller bracket.
4. Fasten with spring locking pin (C).

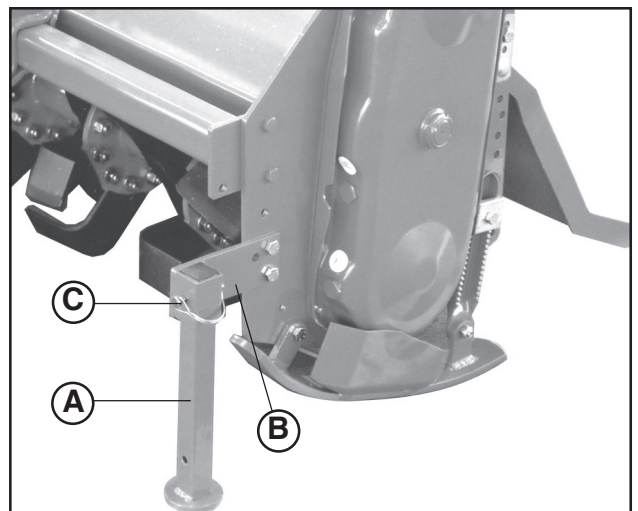

Leveling attachments (side-to-side)

1. Start the engine. Raise the tiller.
2. Stop the engine. Lock the park brake.



CAUTION: DO NOT work under a raised tiller unless it is safely supported.

OPERATING

Leveling tiller (front-to-rear)

1. Start the engine.
2. Lower the tiller to 25 mm (1 in.) off the ground.
3. Stop the engine.
4. Make sure the top of the tiller is LEVEL, or PARALLEL with the ground, front-to-rear.
5. Adjust level, if necessary. To adjust level:
 - a. Start the engine.
 - b. Lower the tiller to the ground.
 - c. Stop the engine.
 - d. Loosen jam nut (A).
 - Shorten the center link (B) to lower the front of the tiller.
 - Lengthen the center link (B) to raise the front of the tiller.
 - e. Tighten jam nut.

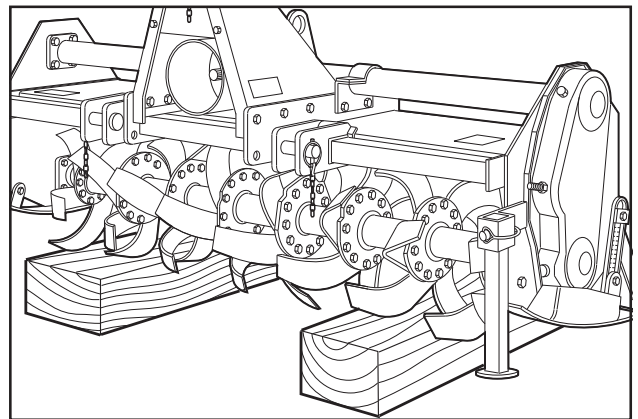
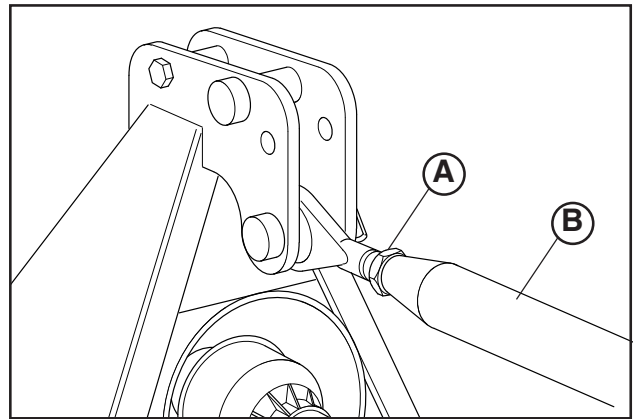

CAUTION: Before you work around hitch:

- STOP engine.
- LOCK park brake.
- FIRMLY block tiller on horizontal surface.

Adjusting skid shoes

Before adjusting skid shoes lift tiller, place tiller on top of two wooden blocks underneath tiller rotor (see figure).

1. Raise tiller.
2. Place wooden blocks.
3. Lower tiller on wooden blocks.
4. Loosen pivot bolt (A) and (D).
5. Loosen adjusting bolt (B) and lock nut.
6. Adjust skid shoe (C) to desired position.
7. Tighten bolts (A), (B) and (D).

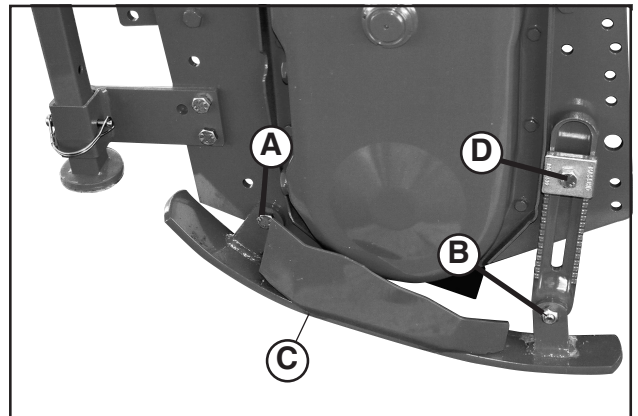

NOTE: Adjust both skid shoes to same depth.

6. Repeat above steps for the other skid shoe.

Adjusting leveling board

1. Install chain (A) in bracket (B).

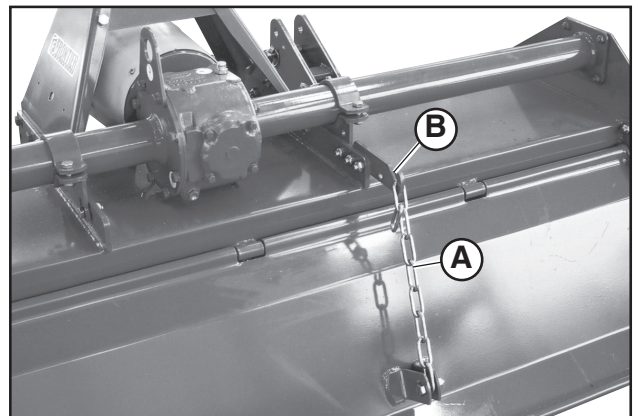

OPERATING

- Lower leveling board to top of ground (C):
 - Tilled soil (D) will be fine and level.
 - Tractor speed will determine size of clods (E).
- Raise leveling board (C):
 - Tilled soil (D) will be coarse and rough.
 - Tractor speed will determine size of clods (E).

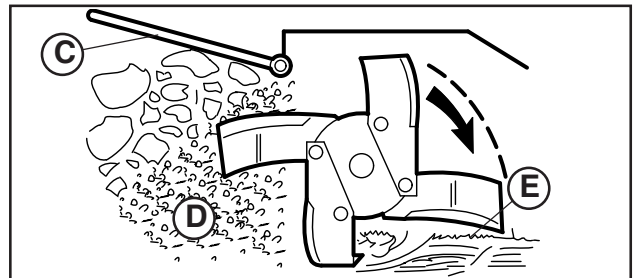
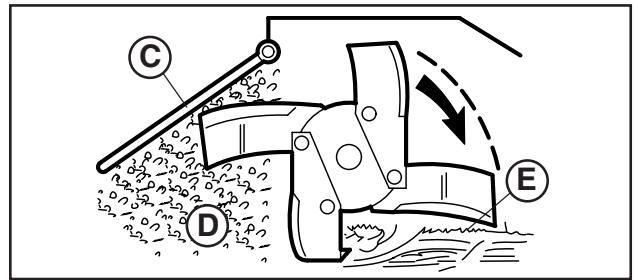

CAUTION: Before you work around hitch:

- STOP engine.
- LOCK park brake.
- FIRMLY block tiller on horizontal surface.

Adjustable offset

The tiller unit can be shifted sideways in relation to the three-point hitch. This makes the implement extremely versatile during the various working conditions.

Use of the hexagonal drive shaft allows the tiller unit to quickly slide, thus notably simplifying the operation.

The following operations must be carried out:

RT 1142 - 1149

- Thoroughly clean the frame and relative guides to allow the parts to work smoothly.
- Loosen the bolts (A) that fix the bracket and leave these free.
- Move the carriage to the position required and the tighten the two carriage fixing bolts.

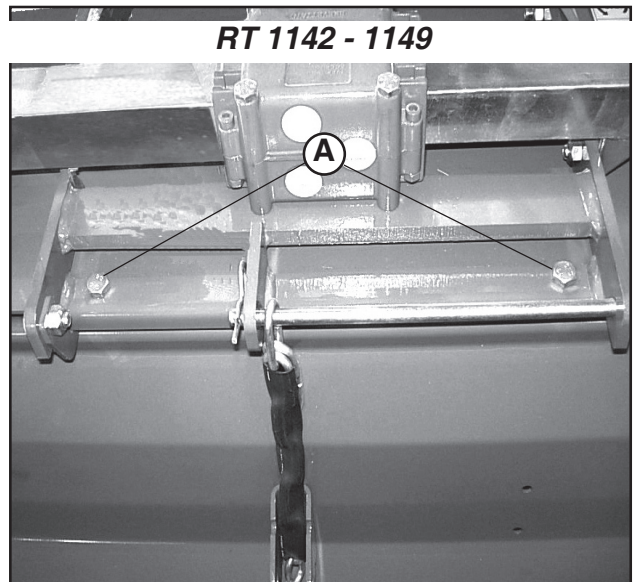

RT 1157 - 1165

- Thoroughly clean the frame and relative guides to allow the parts to work smoothly.
- Loosen the bolts (B) that fix the bracket and leave these free.
- Move the carriage to the position required and the tighten the two carriage fixing bolts.

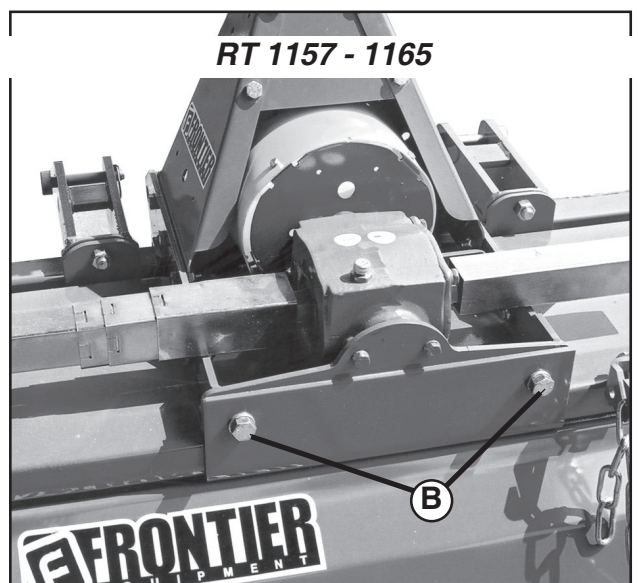

OPERATING

Tilling tips

Before You till:

- Pick up rocks and foreign objects.
- Mow tall weeds and grass to keep them from wrapping around tines or tine shaft.
- Check tines. Loose, bent, broken, or missing tines reduce operating efficiency. If necessary, replace tines.

Test the soil by squeezing it in your hand. If soil forms a ball, it is too wet to till. If soil does not compress easily or falls apart, it is ready to till.

DO NOT till when soil is wet. Wet soil will stick to the tines and tine shaft. Wet soil will also dry out and become hard, making it hard to work with during the growing season.

During tilling



CAUTION: Never lower tiller into the ground while the tractor is turning.

- DO NOT back up or make sharp turn with tiller in ground.
- Move PTO switch lever to ON when tiller is out of the ground. Move tractor forward and lower tiller into the ground.
- When you till hard ground or sod, till at a shallow depth on first pass. Increase depth on each pass.
- When tilling on a hillside:
 - Work up the the slope, if possible.
 - If lateral work cannot be avoided, work from the top to the bottom in order to limit any terracing effect.

Replacement parts

See Service Dealer for original parts.

PART NUMBERS MAY CHANGE, use part numbers listed at the end of this manual when you order. If a number changes, your dealer will have the latest number.

WHEN YOU ORDER PARTS, your Frontier Equipment dealer needs your machine serial number. This is the number you have recorded in the INTRODUCTION section in the front of this manual.

SERVICE MACHINE SAFELY

Practice safe maintenance

- Understand service procedure before doing work. Keep area clean and dry.



- Never lubricate, service, or adjust machine while it is moving. Keep safety devices in place and in working condition. Keep hardware tight.
- To prevent from getting caught, keep hands, feet, clothing, jewelry, and long hair away from any moving parts.
- Before servicing machine, lower it to the ground. Disengage all power and stop the vehicle engine. Lock vehicle park brake and remove the key.
- Securely support any machine elements that must be raised for maintenance.
- Keep all parts in good condition and properly installed. Fix damage immediately. Replace worn or broken parts. Remove any buildup of grease, oil, or debris.
- Unauthorized modifications to the machine may impair its function and safety.

Wear appropriate clothing



- Wear close fitting clothing and safety equipment appropriate for the job.
- Loud noise can cause impairment or loss of hearing, wear a suitable protective device such as ear-plugs.
- Do not wear radio or music headphones while servicing the machine. Safe servicing requires your full attention.

Stay clear of rotating drivelines



Entanglement in rotating driveline can cause serious injury or death:

- Stop the engine and be sure PTO drivelines is stopped before getting near it.

SERVICE LUBRICATION

Service lubrication



- WARNING:**
- Firmly block tiller on horizontal surface.
 - Always keep oils and greases well away from children's reach.
 - Always thoroughly read the warnings and precautions indicated on the containers. Avoid contact with the skin.
 - Always thoroughly and fully wash after use. The utilized oils should be treated in compliance with the current anti-pollution laws.

Every 8 work hours

- Grease the cardan shaft cross journals (A) and (B).
- Check that the bolts fixing the hoe blades (M) are well tightened.
- Grease the rotor spindles (D).

Every 50 work hours *(see page 23 for E, F, G, I and H)*

- Check the level of the oil in the gearbox or in the reduction unit (E) and top off to the level mark on the rod as necessary.
- **Transmission chain:** check the level of the oil in the side casing of the transmission unit, unscrew the level plug (G) and check that oil flows out. Add oil through the fill plug (F) if necessary. It should flow from the level plug (G).

Every 400 work hours

- Change the oil in the reduction unit and transmission casing by completely draining off the old oil through the drain plug under the reduction unit and through the transmission drain plug.
- When this operation is carried out, it is also advisable to demount and clean the clutch disks (C) (if the cardan shaft has a clutch). Check the tightening of the clutch springs.

Every 1000 work hours

Greasing chain (RT 1142 - 1149)

1. Install park stand.
2. Lower tiller to the ground.
3. Remove all bolts and nuts (A).
4. Remove cover (B).
5. Put a heavy coat of moly high temperature extreme pressure grease GR MU EP2 or an equivalent on chain and sprockets.

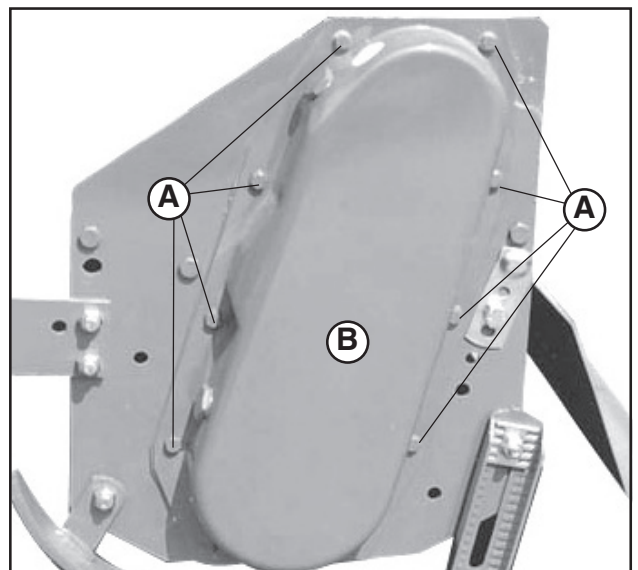
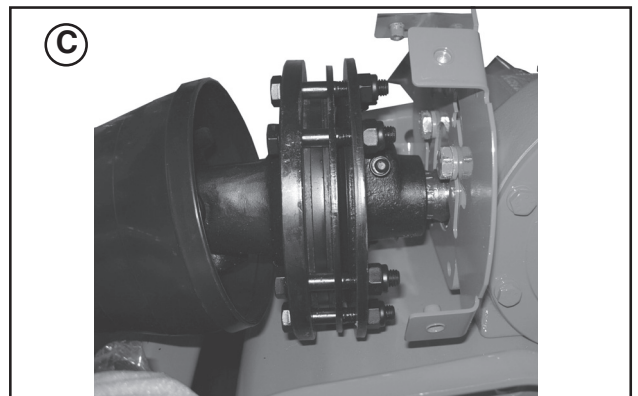
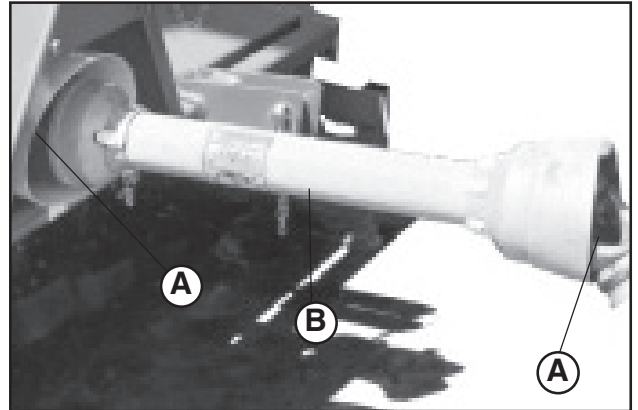

SERVICE LUBRICATION

Greasing and lubricant points RT 1142 - 1149 model

- D) Rotor spindle lubricator
- E) Reduction unit oil plug: Qty. 0.5 lt
(0.13 US gal.)
- M) Hoe blades fixing bolts
- N) Greasing chain (see Service lubrication:
Every 1000 working hours):
Qty. 0.5 Kg (1.1 lb)

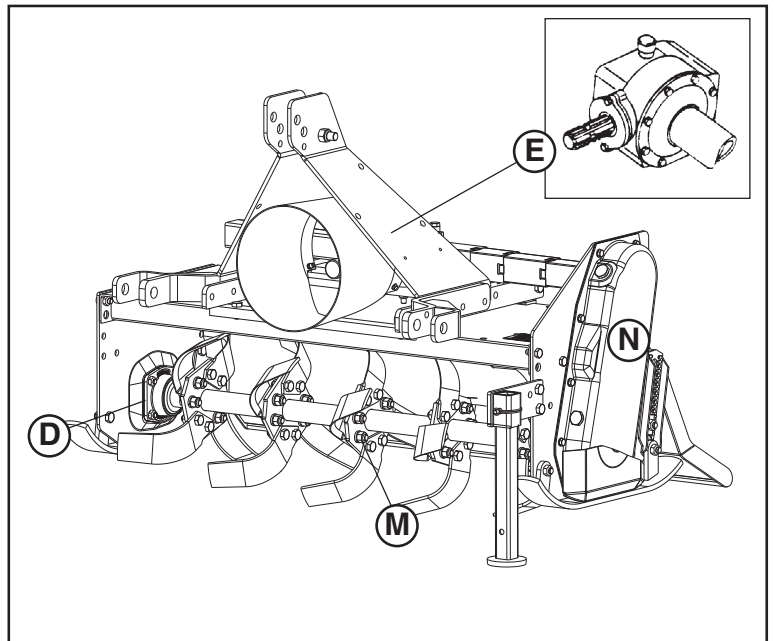

Greasing and lubricant points RT 1157 - 1165 and 1265 model

- D) Rotor spindle lubricator
- E) Reduction unit oil plug
- F) Transmission oil fill plug
- G) Transmission oil drain plug
- M) Hoe blades fixing bolts

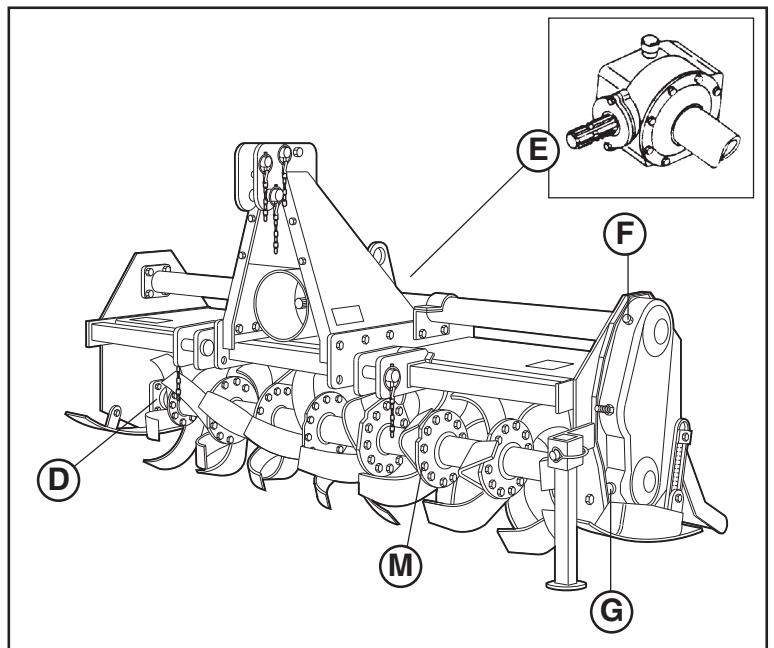

OIL QUANTITY : lt (US gal.)	1157	1265
	1165	
Reduction unit oil (E)	1 (0.26)	0.75 (0.2)
Transmission oil fill chain (F)	1 (0.26)	0.75 (0.2)

Lubricants

- It is advisable to use **SAE 85W/140 OIL** or equivalent for the reduction unit (or gear box) and side transmission.
- It is advisable to use **GRMU EP2 GREASE** or equivalent for all greasing points.

SERVICE

Chain stretcher

RT 1142-1149 and RT 1157-1165 model

Automatic chain stretcher regulates the tension of the drive chain.

RT 1265 model

A special mechanical chain stretcher regulates the tension of the drive chain (A). If there is too much play, then you must loosen lock nut (B) and tighten screw (C) as much as necessary.

Then tighten lock nut which locks the adjustment screw into place.

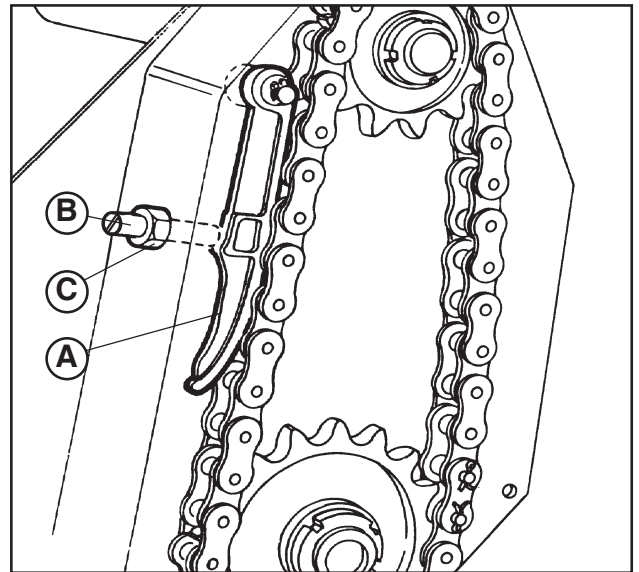

Service intervals

Every 50 working hours:

- Tighten mast brackets bolts.
- Tighten skid shoe bolts.

Bolts tightening torques - settings given in Nm (lb-ft)

Fine pitch screws	CLASS			
	6.6	8.8	10.9	12.9
M8 x 1	15 (11)	26 (19)	36 (26.5)	44 (32.5)
M10 x 1.25	30 (22)	52 (38)	74 (54)	88 (65)
M12 x 1.25	51 (37.5)	91 (67)	127 (94)	153 (113)
M14 x 1.5	81 (60)	143 (105)	201 (148)	241 (178)
M16 x 1.5	120 (88)	214 (158)	301 (222)	361 (266)
M18 x 1.5	173 (127)	308 (227)	433 (319)	520 (384)
M20 x 1.5	242 (178)	431 (318)	606 (447)	727 (536)
M22 x 1.5	321 (237)	571 (421)	803 (592)	964 (711)
M24 x 2	411 (303)	731 (539)	1028 (758)	1234 (910)
M27 x 2	601 (443)	1070 (790)	1504 (1110)	1806 (1333)
M30 x 2	832 (614)	1480 (1090)	2081 (1535)	2498 (1843)

Replacing tines



CAUTION: To prevent injury: Wear heavy gloves when replacing tines.

To get the best performance from your tiller:

- Replace badly bent, worn, or broken tines immediately.
- Replace worn or broken hardware (see your Frontier dealer for correct hardware).
- MAKE SURE to replace tines on ONE spindle at time to keep spiral tine pattern.
- Tine cutting edge MUST BE facing forward in direction of tine rotation.

SERVICE

CAUTION: Make sure you block tiller before doing any service on the tiller.



- STOP engine.
- LOCK park brake.
- FIRMLY block tiller on horizontal surface.

Tines can be changed with the tiller mounted on tractor. Make sure you block the tiller before doing any service on the tiller.

Tines

Before replacing tines make sure the tiller is firmly blocked.

The tines with which the rotary tiller is equipped can work soils of normal conformation. Check the degree of wear and condition of the tines each day. If the blades should accidentally bend (or break) during work, they must be immediately replaced.

First - Identify tines:

Remember to mount the new tine in exactly the same position as the old one (A). If several tines must be replaced, it is advisable to remove and assemble one tine at a time in order to prevent positioning errors. The tillers are normally equipped with 4 blades per flange.

Second - Install New Tines:

1. Raise tiller with a safe lifting device.
1. Put safety stands or blocks under tiller.
3. Stand facing rear of tiller and study placement of tines.
4. Remove four bolts, lock washers, and nuts (C).

NOTE: Make sure to replace tines on ONE spindle at a time to keep spiral tine pattern.

5. Remove left-hand tine (A) and right-hand tine (B).
6. Install new tines and fasten with bolts, lock washers, and nuts (removed above).

NOTE: Two bolts go in from each side. Refer to sketch at right.

7. Tighten bolts.



CAUTION: The heads of the bolts fixing the hoe blades in place must be on the side of the hoe blades themselves, while the nut with relative washer must be on the flange side (B). Tighten bolts to 91 Nm (67 lb-ft).

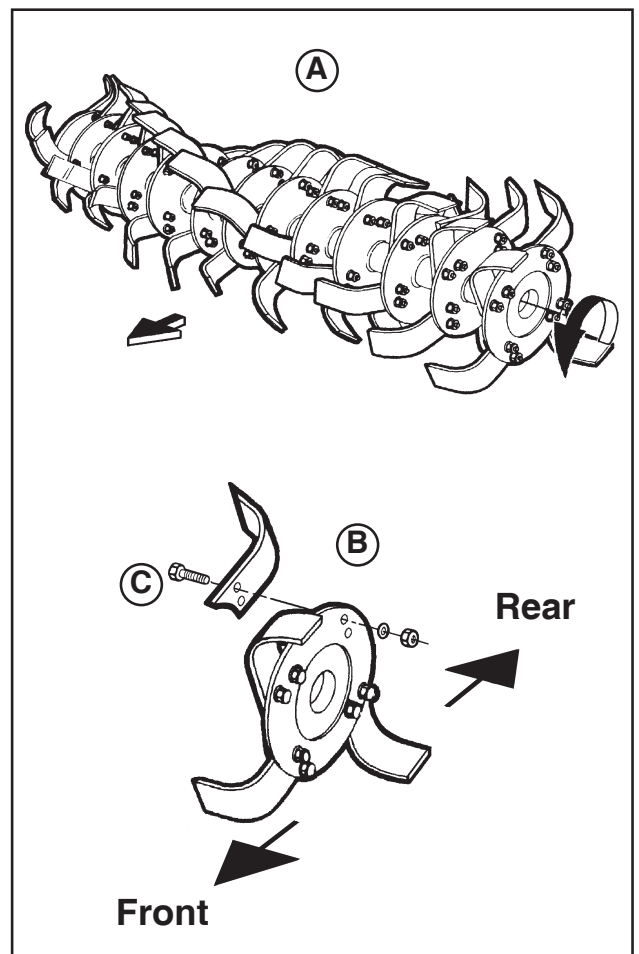

TROUBLESHOOTING

Using troubleshooting chart

If you are experiencing a problem that is not listed in this chart, see your Frontier dealer for service. When you have checked all the possible causes listed and you are still experiencing the problem, see your Frontier dealer.

IF	CHECK
EXCESSIVE TINE WEAR	Replace loose or bent tine. Replace tine when worn to a point.
TILLER BUMPING ON GROUND	Obstacles entangled in tines. Blades incorrectly mounted with no tine spiral effect. Tines fitted with blunt edge leading. Broken tines.
INSUFFICIENT DEPTH OBTAINED	Adjust depth control skids. Insufficient power - use lower tractor speed. Chain cover on hard soil - further passes required. Blades rolling over ground - use lower tractor speed. Adjust depth control on tractor.
TILLED SOIL TOO FINE	Raise leveling board. Use a faster tractor ground speed.
TILLED SOIL TOO COARSE	Lower leveling board. Use lower tractor speed. Wait until soil is drier.
TINES BALLING UP WITH SOIL	Raise leveling board. Decrease tractor speed. Ground too sticky for working.
CUTTING TOO DEEP ON ONE SIDE	Tiller not level: <ul style="list-style-type: none">• Level tiller.• Adjust depth control skid.
NOT OVERLAPPING	Drive closer to last run. Start in center and go around clockwise. (Tilled soil to the right of the operator.)

STORING MACHINE

Storing tiller



CAUTION: Before you work around hitch:

- **STOP** engine.
- **LOCK** park brake.
- **FIRMLY** block tiller on horizontal surface.

1. Put parking stand in the DOWN position (See Lowering Parking Stand in the Operating Tiller section).
2. Disconnect tiller from tractor (See Removing section).
3. Clean tiller and inside of driveline shield.
4. Repair or replace badly worn or damaged parts.
5. Tighten hardware.
6. Lubricate tiller.
7. Grease chain (See Greasing Chain in the Service - Lubrication section).
8. Store tiller in a dry place on a hard level surface with the parking stand in the LOWERED position.
9. If you store tiller outside, put a waterproof cover on it.

Removing tiller from storage

1. Install tiller on the tractor.

ASSEMBLY

RT 1142 - 1149



CAUTION: FIRMLY block tiller on horizontal surface.

Installing mast braces (PHASE 1)

- 1) Install spacer (D), bolt (F) and nut (B) on mast braces (A and G).
Do not tighten bolts and nuts at this time.

Installing parking stand (PHASE 2, operation 1)

- 2) Put parking stand (O) and fasten bolts (N) and nuts (M).
Tighten lock nuts to the requested tightening torque.

Installing mast braces on tiller (PHASE 2, operation 2)

- 3) Install mast assembly on tiller frame and tighten (see below figure). Bolts (I) and nuts (L) to the the requested tightening torque.
 - Fine Pitch screws: M12 x 1.25
 - Class: 8.8
 - Bolts tightening torques: 91 Nm (67 lb-ft).

ASSEMBLY

RT 1142 - 1149

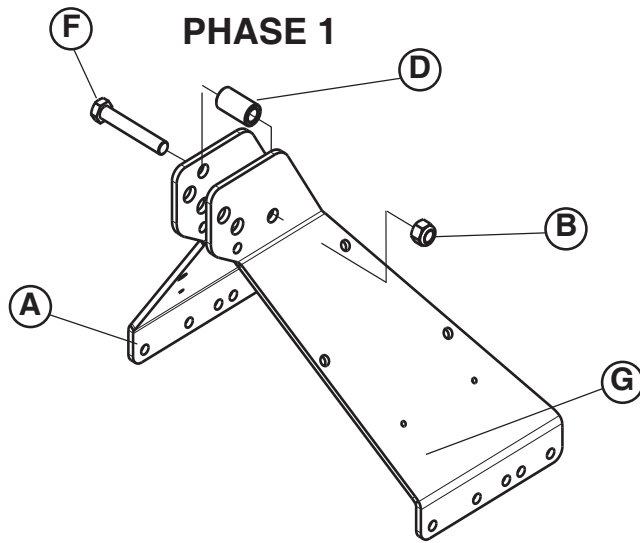

PHASE 2

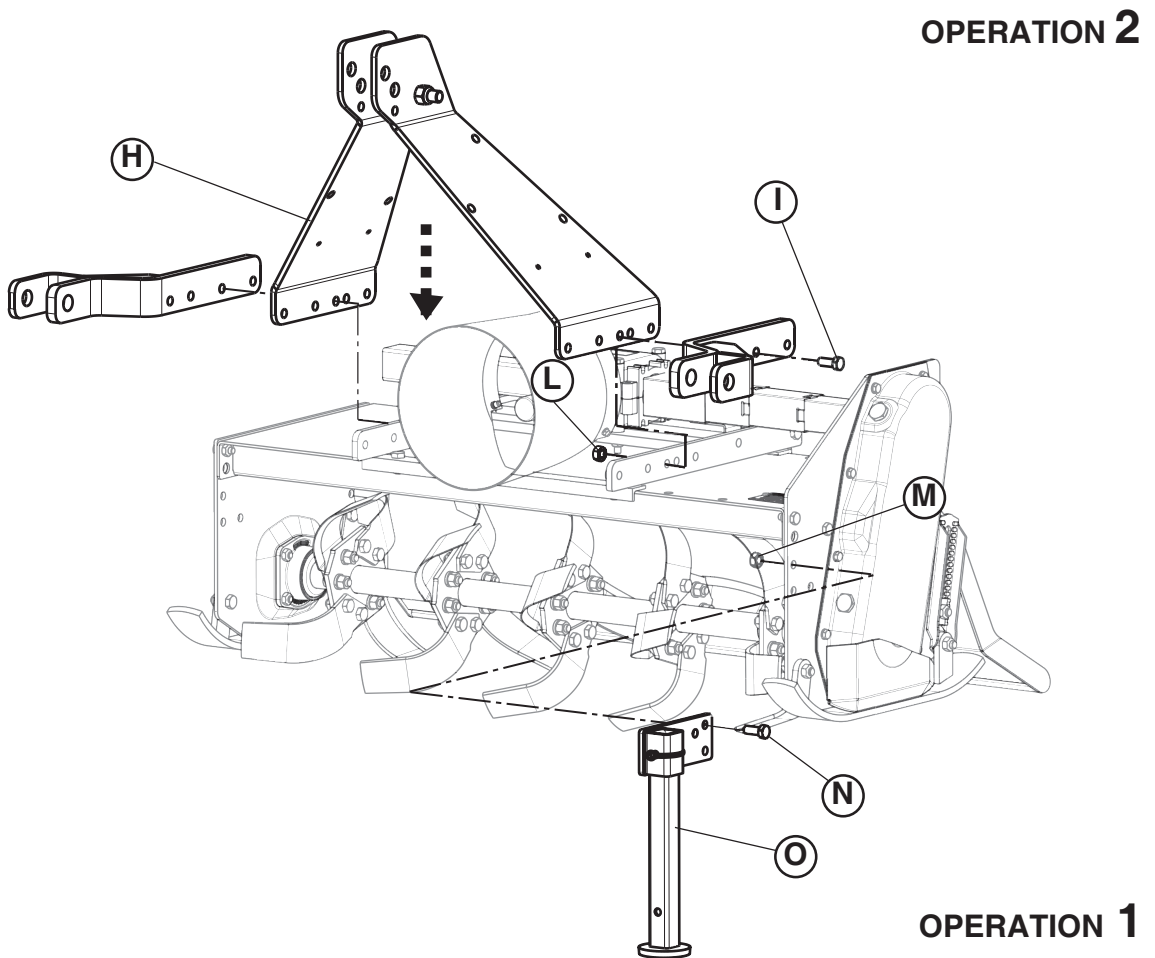

ASSEMBLY

RT 1157 - 1165



CAUTION: FIRMLY block tiller on horizontal surface.

Installing mast braces (PHASE 1)

- 1) Install spacers (D), bolts (E) and nuts (C) on mast braces (I, M) and adaptation plates (A,B)
Do not tighten bolts and nuts at this time.

Installing parking stand (PHASE 2, operation 1)

- 3) Put parking stand (N) and fasten bolts (O) and nuts (P).
Tighten lock nuts to the requested tightening torque.

Installing draft link brackets (PHASE 2, operation 2)

NOTE: big holes on brackets should be on bottom (see figure)

- 4) Put each link bracket (U) and (T) on tool bar and fasten bolts and nuts (V, Z).
Do not tighten bolts and nuts at this time.
- 5) Measure distance between draft link brackets (U). For the correct measurement of the brackets, centered with gearbox, see the table.
- 6) Tighten lock bolts (V) and nuts (Z) to secure draft link brackets to tool bar.
 - Fine Pitch screws: M16 x 1.5
 - Class: 8.8
 - Screw tightening torques: 214 Nm (158 lb-ft).

Installing mast braces on tiller (PHASE 2, operation 3)

- 7) Install mast assembly on tiller frame and tighten bolts (R) and nuts (S) to the the requested tightening torque.
 - Fine Pitch screws: M12 x 1.25
 - Class: 8.8
 - Screw tightening torques: 91 Nm (67 lb-ft).
- 8) Tighten bolt and nut (E and C) to the requested tightening torque: 214 Nm (158 lb-ft).

ASSEMBLY

RT 1157 - 1165

PHASE 1

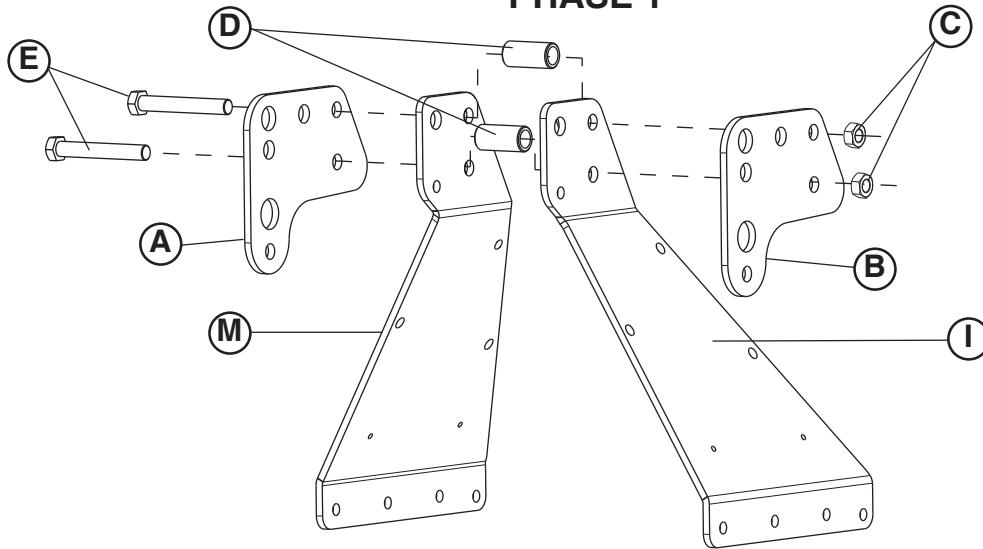

PHASE 2

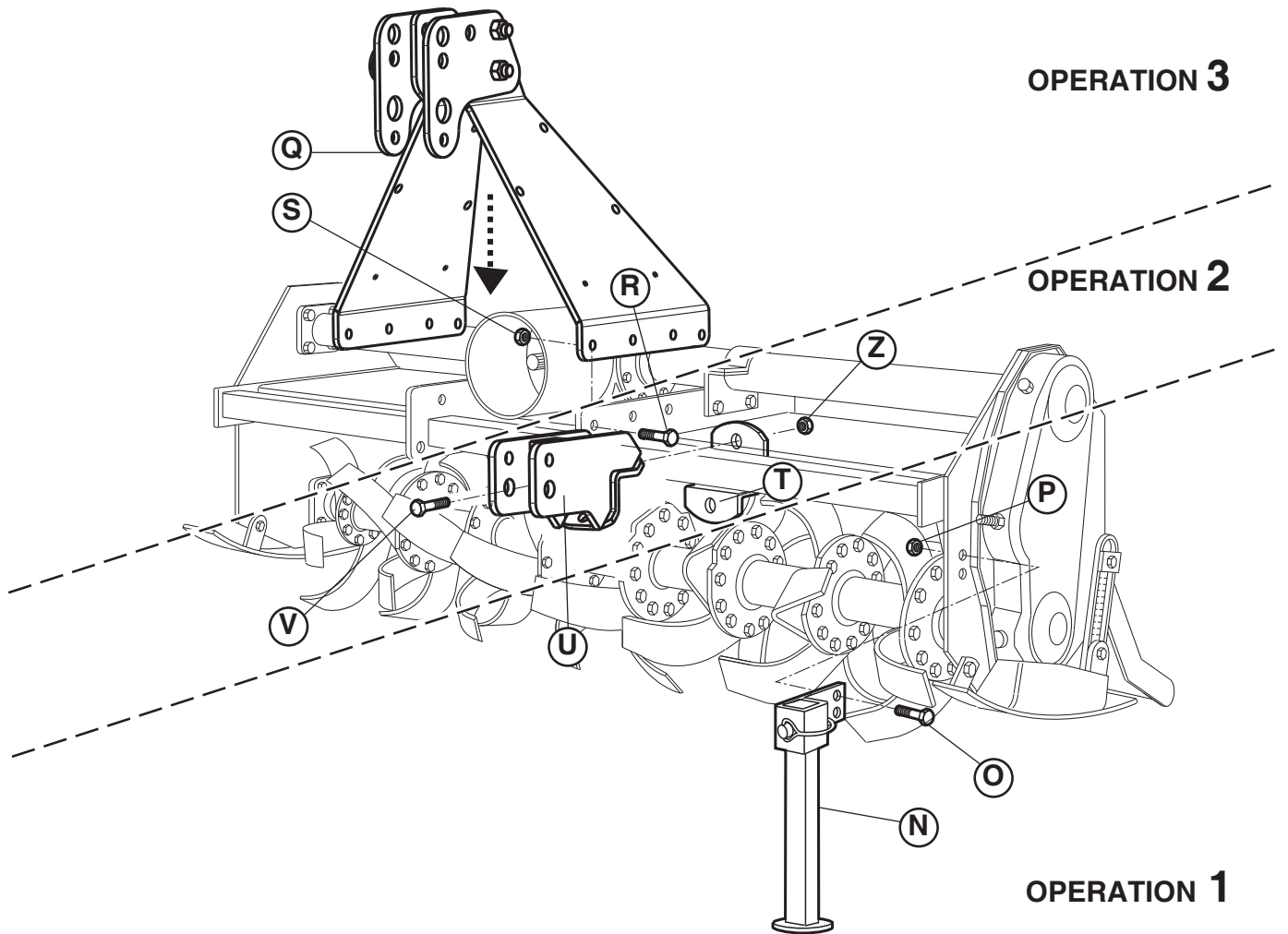

ASSEMBLY

RT 1265



CAUTION: FIRMLY block tiller on horizontal surface.

Installing mast braces (PHASE 1)

- 1) Install spacer (D), bolt (E) and nut (C) on mast braces (I, M).
Do not tighten bolts and nuts at this time.
- 2) Install front and rear plates (B, H) with bolts and nuts (A, F, L, G) on mast braces.
Do not tighten bolts and nuts at this time.

Installing parking stand (PHASE 2, operation 1)

- 3) Put parking stand (N) and fasten bolts (O) and nuts (P).
Tighten lock nuts to the requested tightening torque.

Installing draft link brackets (PHASE 2, operation 2)

NOTE: big holes on brackets should be on bottom (see figure)

- 4) Put each link brackets (U) and (T) on tool bar and fasten bolts and nuts (V, Z).
Do not tighten bolts and nuts at this time.
- 5) Measure distance between draft, link brackets (U). For the correct measurement of the brackets, centered with gearbox, see the table.
- 6) Tighten lock bolts (V) and nuts (Z) to secure draft link brackets to tool bar.
 - Fine Pitch screws: M16 x 1.5
 - Class: 8.8
 - Screw tightening torques: 214 Nm (158 lb-ft).

Installing mast braces on tiller (PHASE 2, operation 3)

- 7) Install mast assembly on tiller frame and tighten bolts (R) and nuts (S) to the the requested tightening torque.
 - Fine Pitch screws: M12 x 1.25
 - Class: 8.8
 - Screw tightening torques: 91 Nm (67 lb-ft).
- 8) Tighten all bolts and nuts (A, L, F and G).
- 9) Tighten bolt and nut (E and C) to the requested tightening torque: 214 Nm (158 lb-ft).

ASSEMBLY

RT 1265

PHASE 1

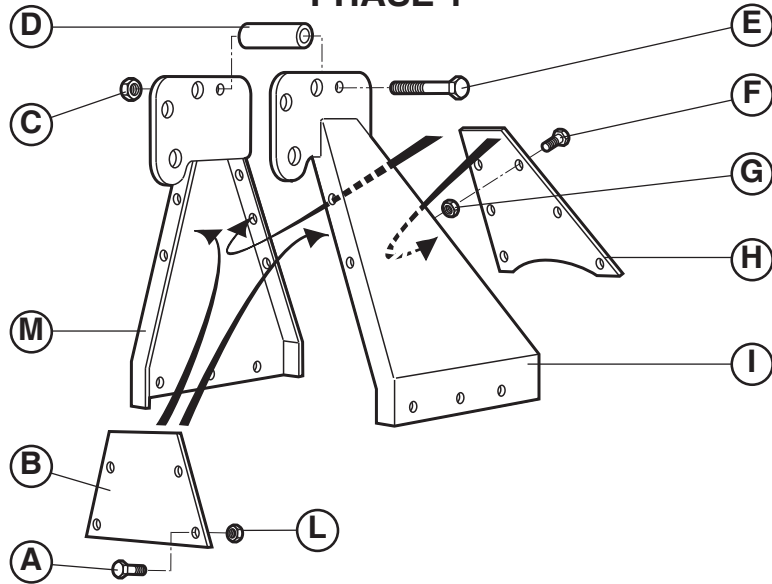

PHASE 2

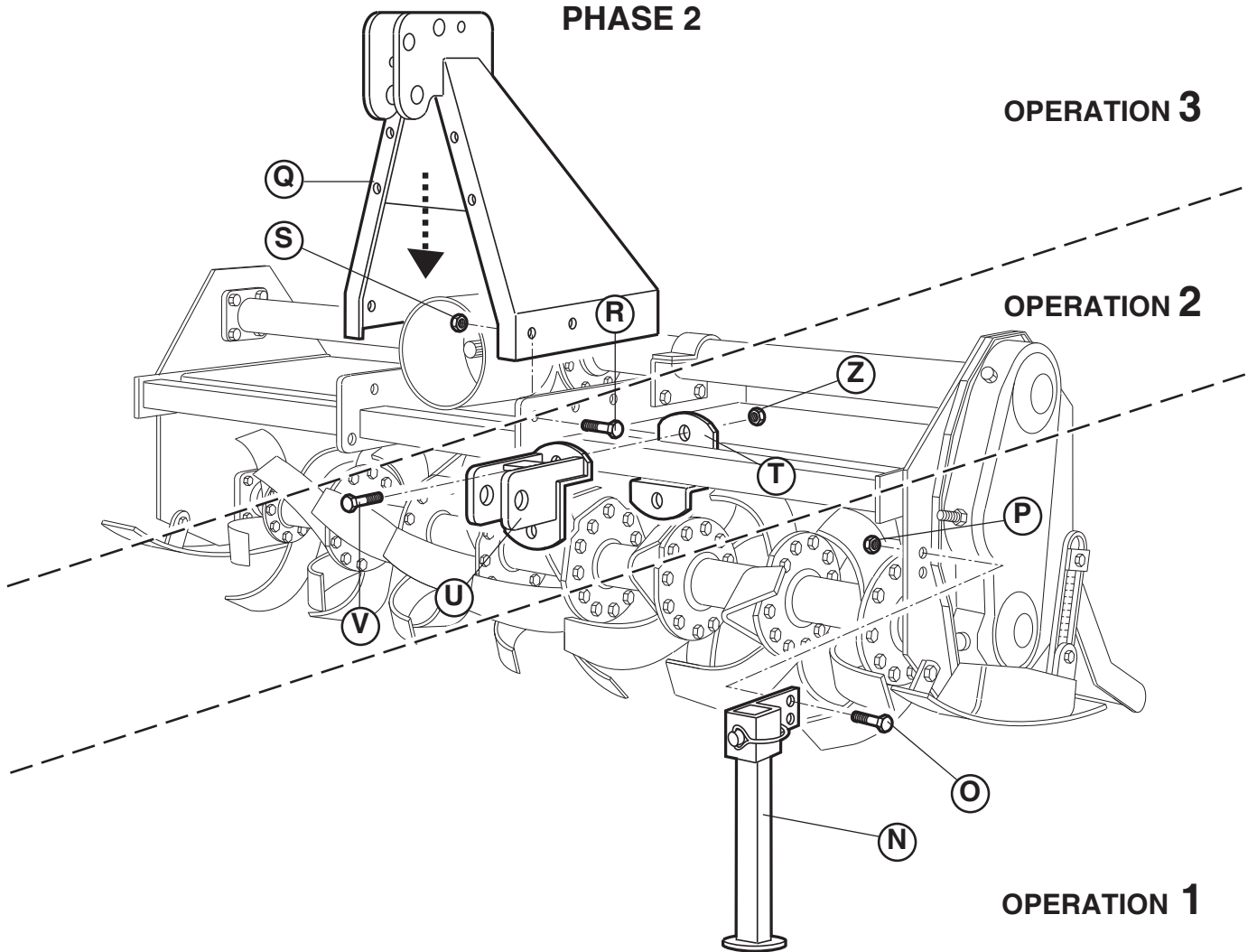

ASSEMBLY / SPARE PARTS

Installing driveline on tiller

NOTE: Shield removed for clarity ONLY. ALWAYS keep shield in place.

1. Pull coupler back and slide driveline on driveshaft until coupler LOCKS in place.

NOTE: You should hear a clicking sound when driveline is properly installed.

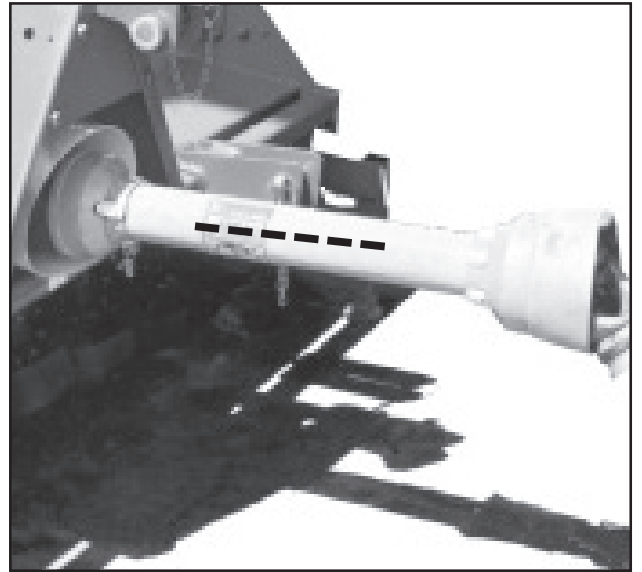

Spare parts

Spare parts should be ordered from your Dealer and should always include the following indications:

- **Type, model and serial number of the machine.** These data are punched on the data plate with which every implement is equipped.
- **Code number of the required spare part.** This will be found in the spare parts catalogue.
- **Description of the part and required quantity.**
- **Table number.**

NOTE: The terms right or left indicated in the descriptions refer to the implement when viewed from the rear side.



Part N°. F07010181



Free Manuals Download Website

<http://myh66.com>

<http://usermanuals.us>

<http://www.somanuals.com>

<http://www.4manuals.cc>

<http://www.manual-lib.com>

<http://www.404manual.com>

<http://www.luxmanual.com>

<http://aubethermostatmanual.com>

Golf course search by state

<http://golfingnear.com>

Email search by domain

<http://emailbydomain.com>

Auto manuals search

<http://auto.somanuals.com>

TV manuals search

<http://tv.somanuals.com>