

JLSS1808
JLFFW1807

frost free fridge freezer

Instruction manual



John Lewis

Important safety information

It is most important that this instruction book should be retained with the appliance for future reference. Should the appliance be sold or transferred to another owner, or should you move house and leave the appliance, always ensure that the book is supplied with the appliance in order that the new owner can get to know the functioning of the appliance and the relevant warnings.

These warnings have been provided in the interest of safety. You **MUST** read them carefully before installing or using the appliance.

If you are unsure of the meaning of these warnings contact the John Lewis branch from which you purchased the appliance.

Installation

- This appliance is heavy. Care should be taken when moving it.
- Check your Fridge Freezer for any transport damage. Do not connect the appliance if there is damage. If the Fridge Freezer is damaged, you should contact the John Lewis branch from which you purchased it.
- Any electrical work required to install this appliance should be carried out by a qualified electrician or competent person.
- Care must be taken to ensure that the appliance does not stand on the electrical supply cable. If the supply cable is damaged it must be replaced; contact our extended warranty administrators on 08700 107 887 who will give you details for your local Service Force centre.
- Parts, which heat up, should not be exposed. Wherever possible, the back of the appliance should be close to a wall, but leaving the required distance for ventilation, as stated in the installation instructions.
- This appliance should be left for 2 hours after installation before it is turned on, in order to allow the refrigerant to settle. Before switching on the Fridge Freezer ensure that the interior light bulb and cover are in position. Do not connect the appliance if they are not.

Child safety

- This appliance is designed to be operated by adults. Children should not be allowed to tamper with the controls or play with the product.
- Keep all packaging well away from children.
- When the appliance is to be scrapped, cut off the electrical supply cable and destroy the plug with the remaining cable. Disable the door catch in order to prevent children from becoming trapped inside while playing.

Use

- This appliance is designed for domestic use only, specifically for the storage of edible foodstuffs only.
- It is not intended for commercial or industrial use.
- Containers with flammable gases or liquids can leak at low temperatures. Do not store any containers with flammable materials, such as spray cans, fire extinguisher refill cartridges etc. in the refrigerator or the vicinity of the refrigerator or any other appliance.
- Frozen food should not be refrozen once it has thawed out.
- Do not place carbonated or fizzy drinks in the freezer compartment.
- Ice lollies can cause frost/freezer burns if consumed straight from the freezer compartment.
- Do not remove items from the freezer compartment if your hands are damp/wet, as this could cause skin abrasions or frost/freezer burns.
- Bottles and cans must not be placed in the freezer compartment as they can burst as the contents freeze.
- Manufacturers recommended food storage times should be adhered to.
- Refer to the relevant instructions.
- Do not use electrical appliances inside the Refrigerator.
- Store pre-packed frozen foods in accordance with the frozen foods instructions and use by date.
- When cleaning or taking out frozen foods or the ice tray do not use sharp, pointed or hard devices, as they can cause damage to the appliance.
- Do not damage the refrigerant circuit.

Safety precautions for isobutane

Warning

- The refrigerant of the appliance is isobutane (R600a) that is inflammable and explosive to a greater extent.
- Keep ventilation openings, in the appliance enclosure or in the built-in structure, clear of obstruction.
- Do not use mechanical devices or other means to accelerate the defrosting process, other than those recommended by the manufacturer.
- Do not damage the refrigerant circuit.
- Do not use electrical appliances inside the food storage compartments of the appliance, unless they are of the type recommended by the manufacturer.

For the safety of life and property keep the precautions of these user's instructions as the manufacturer is not responsible for damages caused by omission.

Maintenance and Cleaning

- Before cleaning, always switch off the appliance and disconnect from the electrical supply.
- Check and clean the drain in the refrigerator compartment for defrosted water regularly; if the drain is blocked, water will gather in the bottom of the refrigerator.
- When unplugging always pull the plug from the mains socket, do not pull on the cable.
- Further information on cleaning is on page 18 of this manual.

Service

- This product should only be serviced by an authorised engineer and only genuine spare parts should be used.
- Under no circumstances should you attempt to repair the appliance yourself. Repairs carried out by inexperienced persons may cause injury or serious malfunction.

Service Force are the authorised repair agents for John Lewis branded domestic appliances.

Ecological hints

To save energy and help protect the environment, we recommend that you follow these hints.

Do not install the appliance close to sources of heat such as a boiler or radiator.

Locate the appliance in a well-ventilated room and make sure that any air openings of the appliance are not obstructed.

Pack all foods into airtight packages before placing them into the freezer compartment.

Food, which is to be frozen (when cool), should be placed in the fridge compartment before being transferred to the freezer.

Try to avoid keeping the door open for long periods or opening the door too frequently as warm air will enter the cabinet and cause the compressor to switch on unnecessarily often.

Ensure there are no obstructions preventing the door from closing properly.

Environmental information

After unpacking please dispose of the packaging with due regard to safety and the environment.

Materials marked with the symbol  are recyclable.

Avoid damaging the cooling unit, especially at the rear near the heat exchanger. Check with your local Council or Environmental Health Office to see if there are facilities in your area for recycling this appliance.

When the appliance is to be scrapped, cut off the power supply cable and remove the door, to prevent young children from being trapped inside.

This appliance does not contain gases, which could damage the ozone layer, in either, its refrigerant circuit or insulation materials.

WARNING

A cut off plug inserted into a 13-amp socket is a serious safety (shock) hazard. Please ensure the cut off plug is disposed of safely.

The symbol  on the product or on its packaging indicates that this product may not be treated as household waste.

Instead it should be taken to the appropriate collection point for the recycling of electrical and electronic equipment. By ensuring this product is disposed of correctly, you will help prevent potential negative consequences for the environment and human health, which could otherwise be caused by inappropriate waste handling of this product. For more detailed information about recycling of this product, please contact your local council, your household waste disposal service or the shop where you purchased the product.

Contents

For the User

Important safety information	2
Installation	2
Description of the appliance	5
The Control Panel	12
Display	12
Switching the appliance on	12
Switching the appliance off	12
Functions Menu	12
Select /Switch off /Switch on each compartment	13
Switch off of one compartment	13
Ambient Temperature Function	13
Child lock Function	13
Using the refrigerator	14
Drawer	14
Use of the fridge compartment	14
Shopping Function	14
Eco mode Function	14
Drinks Chill Function	15
Air Filter	15
Storing in foods the refrigerator	15
Storage time and temperature of foods	15
Using the freezer	16
Use of the freezer compartment	16
Storage of frozen food	16
Temperature regulation	16
Excessive temperature alarm	16
Door open audible alarm	16
Freezing fresh food	16
Storing in the freezer	17
How to make ice cubes	17
Storage time chart (refrigerator)	18
Storage time chart (freezer)	19
Maintenance and Cleaning	19
Defrosting	19
Regular cleaning	19
Internal cleaning	19
External cleaning	19
Changing the Carbon Filter	19
Trouble shooting	20
How to change the bulb	20
Something Not Working	21
Repairs - After Sales Service	22

For the Installer

Installation	6
Technical Specifications	6
Unpacking	7
Cleaning	7
Positioning	7
Climate Classification	7
Installation of the Carbon Filter	8
Change of door opening direction	9
Electrical connection	11

Guide to the Instruction Manual

The following symbols will be found in the text to guide you throughout the instructions:



Safety precautions

Warnings and information at this symbol serve safety for you and your appliance.



Hints and tips



Environmental information



This appliance complies with the following E.E.C. Directives:

- 73/23 EEC of 19.02.73 (Low Voltage Directive) and subsequent modifications,
- 89/336 EEC of 03.05.89 (Electromagnetic Compatibility Directive) and subsequent modifications.

Description of the appliance

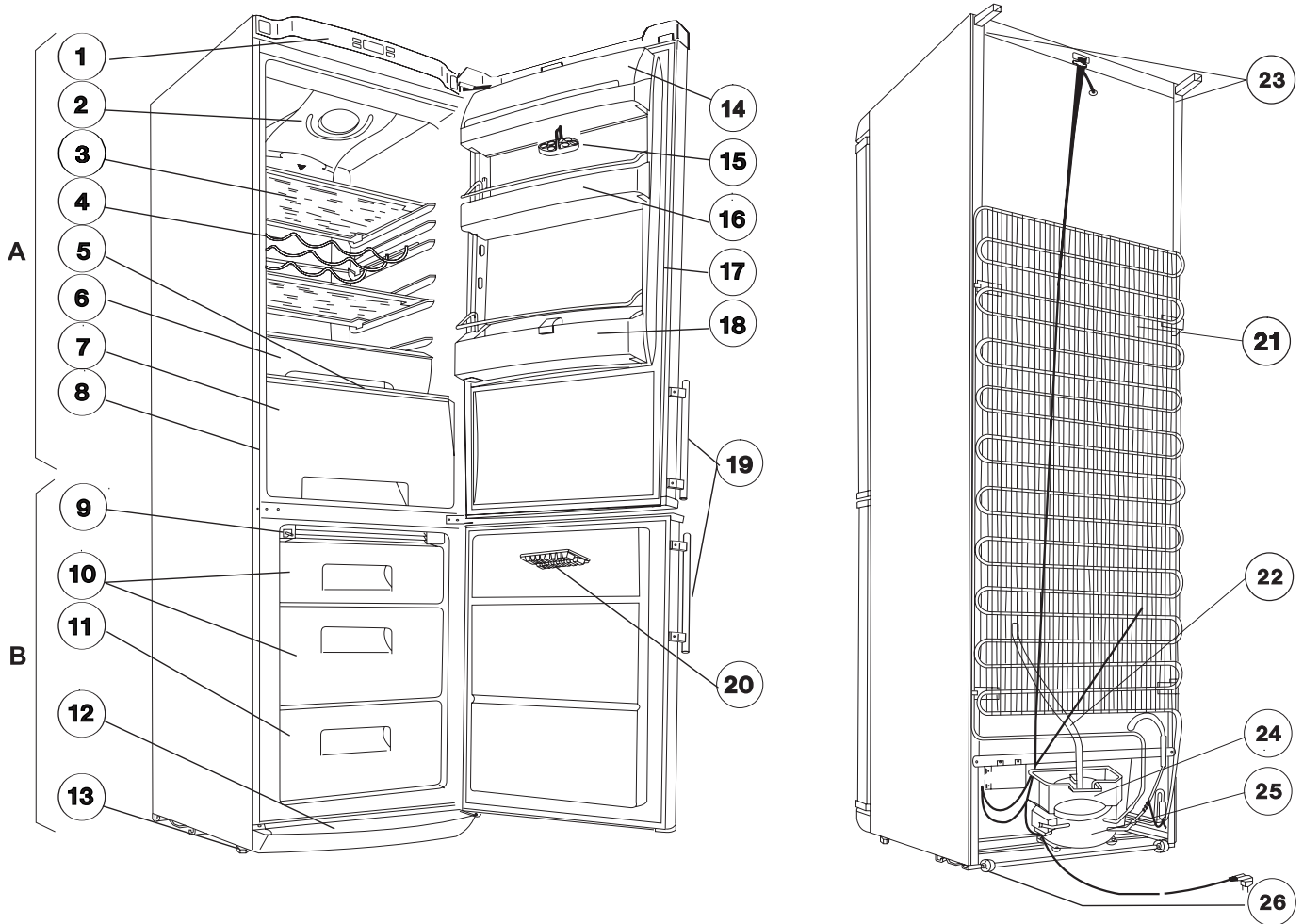



A - Refrigerator

B - Freezer

1. Control panel
2. Air distribution and light box
3. Glass shelves
4. Bottle rack
5. Glass shelf
6. Fresh Box
7. Salad/vegetable drawer
8. Rating Plate
9. Air grid
10. Storing compartment(s)
11. Quick freeze dower
12. Bottom plinth
13. Adjustable feet

14. Dairy compartment
15. Egg tray
16. Door shelf
17. Door seal
18. Bottle shelf
19. Handles
20. Ice tray
21. Condenser
22. Defrost water outlet tube
23. Spacer
24. Evaporator tray
25. Compressor
26. Rollers

Installation

-  It is dangerous to alter the specifications or attempt to modify this product in any way.
-  Care must be taken to ensure that the appliance does not stand on the electrical supply cable.
-  Any electrical work required to install this appliance should be carried out by a qualified electrician or competent person.

Technical Specifications

Dimensions	Width	595 mm
	Height	1850 mm
	Depth	632 mm
Power supply voltage		230V/50Hz
Rated current		0,6 A
Gross capacity	Refrigerator	251 l
	Freezer	91 l
Net capacity	Refrigerator	240 l
	Freezer	78 l
Freezing capacity		10 kg/24 h
Energy consumption		1,027 kWh/24h
		375 kWh/year
Energy class, according to EU standards		A
Rising time		16 h
Noise Lc		42 dB
Weight		73 kg
Number of compressors		1

Unpacking

i The appliance must always be transported in the upright position as indicated on the outside of the packaging.

After each transportation the appliance must not be switched on for approx. 2 hours to ensure the coolant gases settle.

Unpack the Fridge Freezer and check for any possible damage. If the appliance is damaged please report this to the John Lewis branch from which you purchased; in this case please retain the packaging.

Cleaning

Remove all adhesive tape and ties, which ensure the internal fittings do not move during transportation.

Wash the inside of the appliance using lukewarm water and mild detergent; using a soft cloth.

Further cleaning advice is given on page 19.

Positioning

The appliance should be located in a well ventilated, dry room. To ensure correct operation the appliance should:

- Not be exposed to direct sunlight.
- Not be installed next to radiators, cookers or other sources of heat.
- Only be installed in a location where the ambient temperature corresponds to the climate classification for which the appliance is designed.

Climate Classification

The climate classification can be found on the rating plate; which is located on the bottom left hand side of the fridge compartment, see page 5 .

The table shows the correct operating ambient temperature for each climate class.

Class of climate	Ambient temperature
SN	+10...+32°C
N	+16...+32°C
ST	+18...+38°C

If the temperature rises above or falls below the stated ambient temperature for the climate class, the operation of the appliance may be affected.

Ventilation

You should ensure that air can circulate freely around the back and top of the cabinet. In the Instruction manual bag there are two spacers which must be fitted to the top rear corners. This will ensure a gap is maintained between the Fridge Freezer and the wall.

Loosen the screws and insert the spacer under the screw head, then re-tighten the screws.

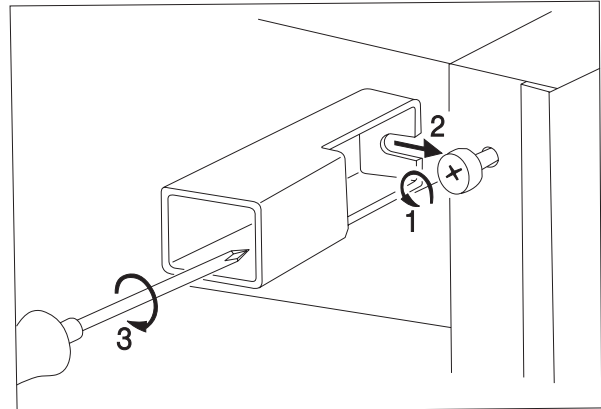

Levelling

When placing the appliance ensure that it stands level, to prevent vibration, excessive noise and to ensure the doors shut correctly.

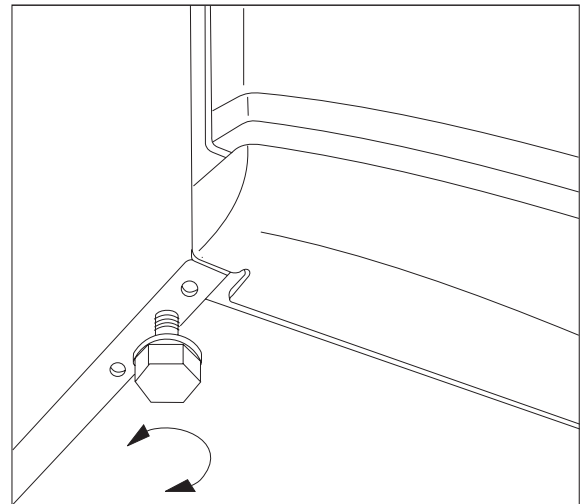

Level the appliance by turning the 2 adjustable feet at the front of the Fridge Freezer.

! When placing the refrigerator keep minimal distances recommended in figure.

A: placing it under a wall-cupboard

B: placing it freely

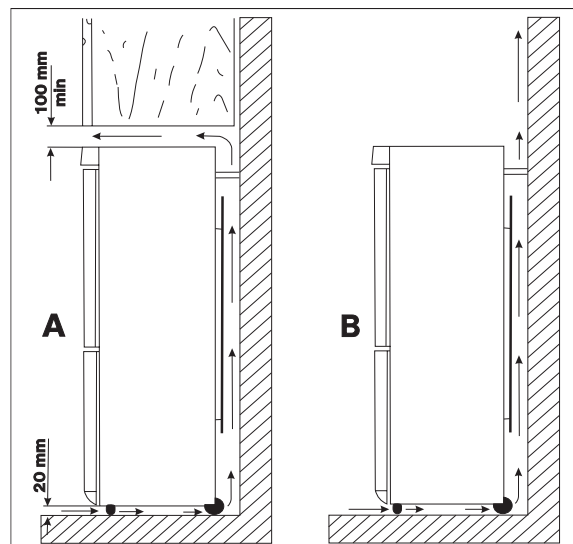

Installation of the Carbon Filter

On delivery the carbon filter is in a plastic bag to maintain its duration and characteristics. The filter should be placed behind the flap before the appliance is turned on.

1. Pull the flap outwards. (1)
2. Remove the filter from the plastic bag.
3. Insert the filter in the slot found in the back of the flap cover (2).
4. Close the flap cover.

i During operation, always keep the air ventilation flap closed.

i The filter should be handled carefully so fragments do not loosen from the surface.

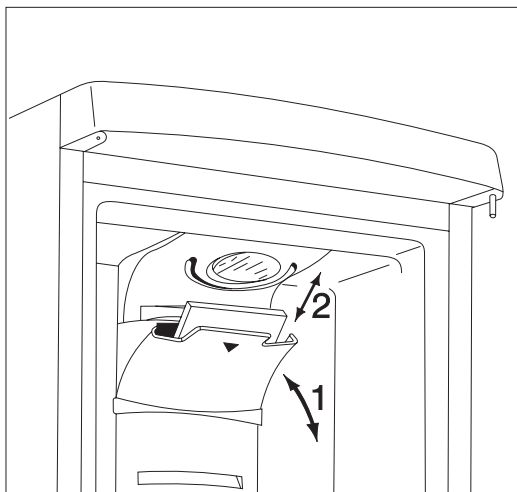

Reversing the fridge freezer doors

Should it be necessary, to suit the placement of the appliance in your kitchen, you can reverse the doors.

The appliances is delivered with the door opening to the right.

Carry out the steps as per the pictures and the instructions.

1. We recommend that you have another person to help you who can safely hold the doors of the appliance secure.
2. Disconnect the appliance from the electrical supply.
3. Open the door of the fridge, dismantle the top cover (j) by removing the 2 screws (a), then close the door (Fig. 2).
4. Move the panel (g) from one side of the top cover (2) to the other (Fig. 2).
5. Unscrew the 2 screws (c), remove the door mount at the top right-hand side (d), and unscrew the screw on the other side (c), remove the panel (b) and place in an empty plastic bag (Fig. 1).
6. Lift the fridge door up slightly and remove.
7. Unscrew the screw (m), remove the door stopper (h) and attach reversed on the other side (Fig. 2).
8. Remove double door mount (a, b, c) from the body of the appliance in steps. Please make sure the plastic spacer (b) under the door mount is also removed (Fig. 3).
9. Lift the freezer door up slightly and remove.
10. Remove stops in both doors (t, z) (Fig. 5).
11. Lift out the insert for the lower covering grid (e) using a screw driver (Fig. 4).
12. Unscrew the bottom door retaining pin for the freezer door (h, f) and then screw in on the other side. Don't forget the spacer (h) (Fig. 4).
13. Insert the insert for the lower covering grid (e) on the other side.
14. Remove the left-hand cover pin of the double door mount (3 pieces, n, k) and move to the other side (Fig. 3).
15. Disassemble the door locking elements (u, v) by unscrewing the screw (s) (Fig. 5).
16. Reverse the door locking elements (u, v), move to the other side of the other door and fix by screwing in the screw (s).
17. Re-insert the stoppers (t, z) on the other side of the doors.
18. Fit the pin of the double door mount (m) into the left-hand hole of the freezer door (Fig. 3).

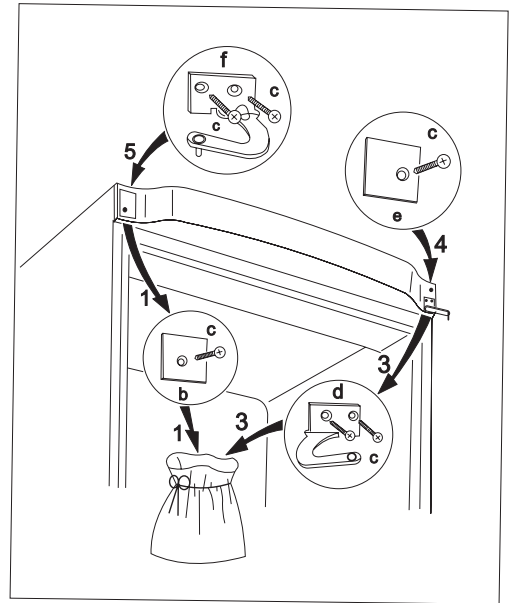

fig. 1.

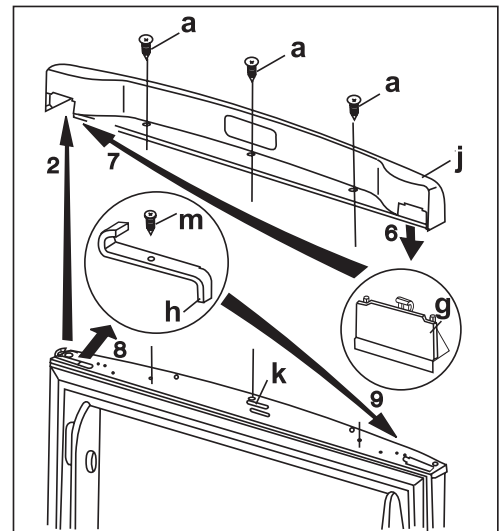

fig. 2.

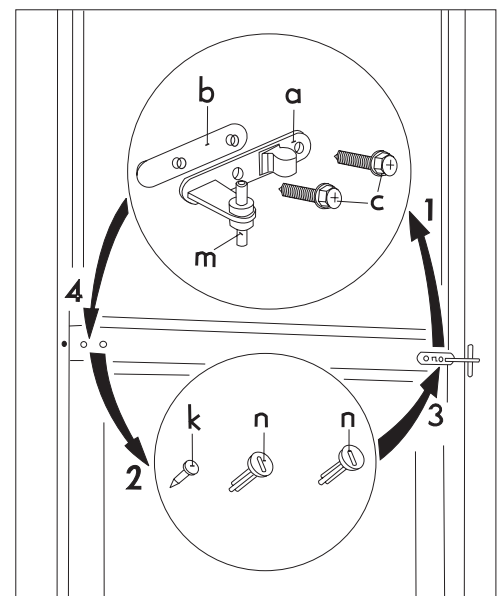

fig. 3.

19. Place the freezer door on the lower door retaining pin (f) (Fig. 4).
 20. Fix the double door mount with 2 screws (c) on the left-hand side. Don't forget the plastic spacer under the door (b) as well. The edges of the doors must run parallel to the side edge of the appliance.
 21. Place the fridge door on the double door retaining pin.
 22. Remove the top left-hand side door mount (f) and the panel (c) from the plastic bag and attach using the screws (c) (Fig. 1).
 23. Open the fridge door, attach the top cover (j) using 2 screws (a); at the same time pay attention to the repositioning of the magnet (k), then close the door (Fig. 2).
 24. Put over the handles (r) on the other side and put the plastic blanking pins (p) supplied in the plastic bag of this instruction book into the holes set free. (fig. 6)
 25. Put the appliance into position, make adjustments if not horizontal and connect to the electrical supply.
- If you do not want to carry out these steps yourself, please contact the nearest branded service point. Technicians will make a charge for door reversal.

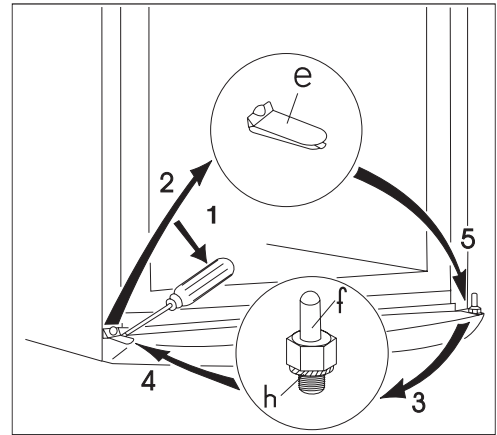

fig. 4.

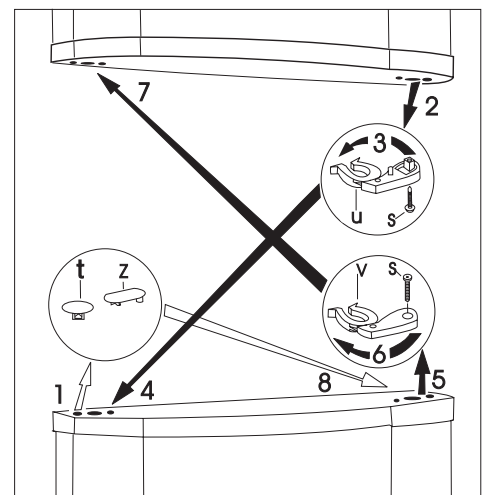

fig. 5.

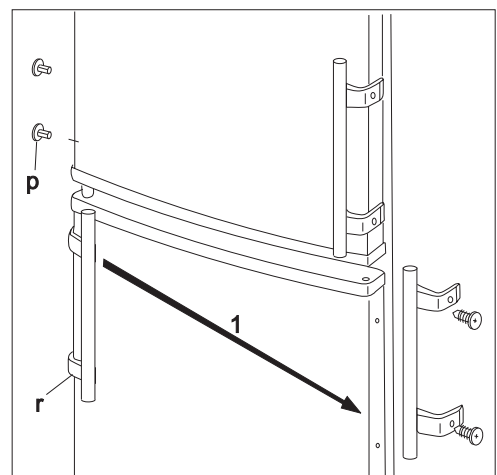

fig. 6.

Electrical connection

Any electrical work required to install this appliance should be carried out by a qualified electrician or competent person.

⚠ WARNING: THIS APPLIANCE MUST BE EARTHED.

Should the appliance power supply cable need to be replaced, this must be carried out by a Service Force agent (see page 22)

The manufacturer declines any liability should this safety measure not be observed.

Before switching on, make sure the electricity supply voltage is the same as that indicated on the appliance's rating plate. (See picture on page 5).

The appliance is supplied with a 13amp plug supplied. In the event of having to change the fuse in the plug supplied, a 13amp ASTA approved BS 1363/A fuse must be used.

Should the plug need to be replaced for any reason, proceed as described below. The wires in the mains lead are coloured in accordance with the following code:

Green and Yellow	- Earth
Blue	- Neutral
Brown	- Live

If you fit your own plug, the colours of the wires in the mains lead of your appliance may not correspond with the markings identifying the terminals in your plug.

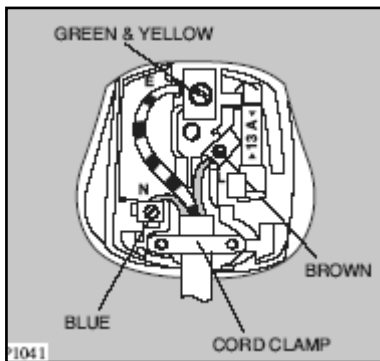

Proceed as follows:

1. Connect the Green and Yellow (earth) wire to the terminal in the plug which is marked with the letter "E" or the earth symbol \oplus or coloured green and yellow.
2. Connect the Blue (neutral) wire to the terminal in the plug which is marked with the letter "N" or coloured black.
3. Connect the Brown (live) wire to the terminal in the plug which is marked with the letter "L" or coloured red.
4. Upon completion there must be no cut, or stray strands of wire present and the cord clamp must be secure over the outer sheath.

⚠ WARNING:
A cut off plug inserted into a 13 amp socket is a serious safety (shock) hazard.

Ensure that the cut off plug is disposed of safely.

⚠ The plug must still be accessible after the appliance has been installed.

⚠ The appliance should not be connected to the electrical supply by means of an extension cable

Permanent connection

In the case of permanent connection it is necessary that you install a double pole switch between the appliance and the electricity supply (mains), with a minimum gap of 3mm between the switch contacts and of a type suitable for the required load in compliance with the current electrical regulations.

The switch must not break the green and yellow earth cable at any point.

The Control Panel

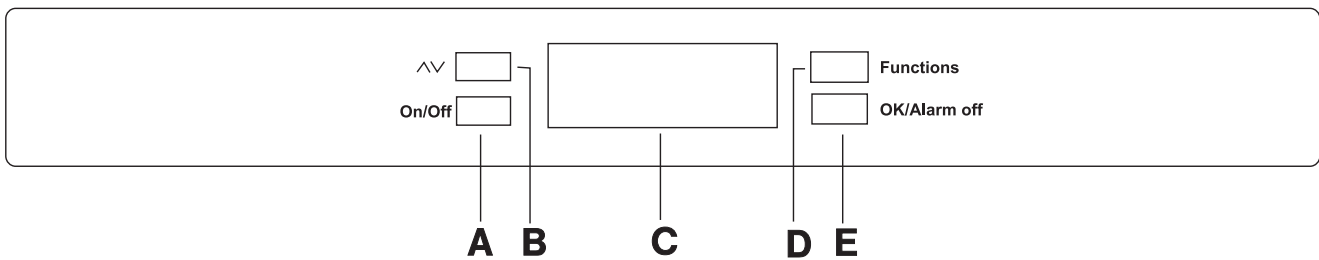

A - Appliance button ON/OFF

B - Temperature regulation button

C - Temperature and function display

D - Function button

E - Confirmation button

+5°C in the fridge

-18°C in the freezer

- Wait until the inside compartment temperature reach -18°C, before placing food in the freezer compartment.
- To select a different temperature see "Temperature regulation".

Display



if indicates the compartment is on;

if indicates the temperature of the relevant compartments

if it flashes the operations corresponds to the relative compartment

High temperature alarm and Door open audible alarm Indicator

indicates the ambient room temperature

Positive or negative Temperature indicator

Temperature indicator

If on, the function child lock is on

If on, the function timer is on

If on, the shopping function is on

If on, the Chill mode function is on

If on, the quick freeze function is on

If on, the Eco mode function is on

Switching the appliance on

Once connected to the mains supply, if the display is not illuminated, press key (A), to switch the appliance on.

As soon as the appliance is turned on, it is in alarm mode, the temperature flashes and you will hear a buzzer.

Press key (E) and the buzzer will go off (also see the section on "high temperature alarm") the icon still flashes and on the indicator will show the warmest temperature reached.

For correct storage of the food select the Eco mode function that guarantee the following temperatures are set:

Important

If the door remains ajar for some minutes, the internal lighting will turn off electronically; after this, the lighting function will be reset by closing and opening the door itself.

Switching the appliance off

The appliance is switched off by pressing key (A) for more than 1 second. After this, a countdown of the temperature from -3 -2 -1 will be shown.

Functions Menu

By pressing the key D the functions menu is open. Each function can be selected by pressing button E. If there is no confirmation after some seconds the display will exit from the menu and return to normal mode.

The following functions are available:

Select/Switch off/Switch on fridge compartment

Select/Switch off/Switch on freezer compartment

Ambient Temperature

Child lock function

Shopping function

Eco mode function

Quick freeze function

Chill mode function (or timer function)

Select /Switch off /Switch on each compartment

Temperature selection

The temperature may be regulated by pressing the key (D) to select the compartment and then the key (B) to set the desired temperature.

By pressing the key (B) the current temperature setting flashes on the indicator. To confirm the choice of temperature press the key (E). You will hear the buzzer for few seconds and the indicator displays the newly selected temperature for a few seconds, then shows again the inside compartment temperature.

The newly selected-temperature will be reached after 24 hours.

The temperature will remain stored even if the product is not in use.

Attention!

During the stability period by the first starting the temperature displayed can not correspond to the setting temperature. During this time it is possible that the temperature displayed is different than the setting temperature.

Switching off one compartment

To switch off one compartment press the key (D) until the compartment is selected and then press hold of key (A), the count down will begin.

Ambient Temperature Function

The ambient temperature function is activated by pressing key D (several times if necessary) until the corresponding icon appears  .

In this condition the selected temperature is the ambient temperature.

You must confirm the choice by pressing key E within a few seconds. You will hear the buzzer and the icon will remain lit. It is possible to de-activate the function at any time by pressing key D until the corresponding icon will flash and then press key E.

Child lock Function

The child lock function is activated by pressing key D (several times if necessary) until the corresponding icon appears  .

You must confirm the choice by pressing key E within a few seconds. You will hear the buzzer and the icon remains lit.

With this function activated, the programmed temperatures and settings remain, even if any of the keys are pressed.

It is possible to de-activate the function at any time by pressing key D until the corresponding icon flashes and then pressing key E.

Using the refrigerator

i To maintain the selected cooling temperature within the refrigerator air must be allowed to circulate. Ensure the air circulation gaps behind the shelves are not covered.

i Always allow hot foods to cool to room temperature before placing into the refrigerator. This will avoid a build up of frost.

i Foods can transfer or take in odours from other foods. So it is essential to put foods in closed dishes or wrap them in cellophane, aluminium foil, grease-proof paper or cling film before placing them into the refrigerator. This way foods will keep their moisture e.g. vegetables will not dry out after some days.

Salad/Vegetable drawer

The drawer is suitable for storing fruit, vegetables and salad. There is a separator inside the drawer that can be placed in different position to accommodate your personal food requirements.

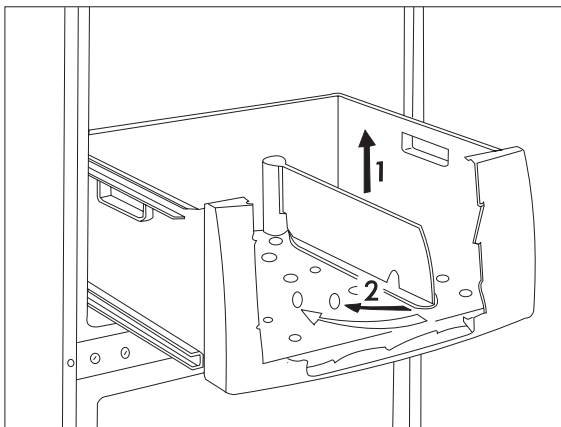

Use of the fridge compartment

Temperature regulation

The temperature of this compartment can set between +2°C and +8°C.

During normal operation the indicator shows the temperature inside the fridge.

Attention!

Difference between the temperature displayed and temperature setting is normal. Especially when:

- a new setting has recently been selected
- the door has been left open for a long time
- warm food has been placed in the compartment.

Holiday Function "H"

The holiday function sets the temperature at + 15°C.

This function allows you to keep the refrigerator shut and empty during a long holiday period (e. g.

the summer holidays) preventing bad smells forming.

1. To turn on the holiday function operate as per changing the selected temperature. The temperature indicator can change the displayed temperature up to + 8 °C, 1 °C at a time. + 2 °C will be followed by the letter "H". Press key E to confirm.

Now the refrigerator is in the "holiday function" in the energy saving mode.

Attention!

The fridge compartment must be empty with holiday function on.

Shopping Function

If you need to place a large amount of warm food in the fridge, e.g. after doing the grocery shopping, we suggest activating the Shopping function to chill the products more rapidly and to avoid warming the other food which is already in the refrigerator.

The shopping function is activated by pressing key D (several times if necessary) until the corresponding icon appears .

You must confirm the choice by pressing key E within a few seconds. You will hear the buzzer and the icon will remain lit.

The shopping function shuts off automatically after approximately 6 hours.

It is possible to de-activate the function at any time by pressing key D until the corresponding icon flashes and then pressing key E.

Eco mode Function

The Eco mode function is activated by pressing key D (several times if necessary) until the corresponding icon appears .

You must confirm the choice by pressing key E within a few seconds. You will hear the buzzer and the icon will remain lit.

In this mode the chosen temperatures are automatically set (+ 5°C e - 18°C), in the best conditions for storing food.

It is possible to de-activate the function at any time by changing the selected temperature in one of the compartments.



Drinks Chill Function

The Drinks Chill function is used for the rapid cooling of the drinks in the freezer compartment. It is activated by pressing key D (several times if necessary) until the corresponding icon appears .

You must confirm the choice by pressing key E within a few seconds. You will hear the buzzer and the icon remains lit.

In this mode it sets a timer with a default value of 30 min which can be changed from 1 to 90 min, by pressing key B.

At the end of the selected time there are the following indications:

- on the display the symbol flashes ;
- the icon flashing  ;
- the icon flashing  ;
- sounding of an acoustic alarm until key E is pressed.

At this point remove the drinks contained in the freezer compartment.

It is possible to de-activate the function at any time by pressing key D until the corresponding icon flashes and then pressing key E

Air Filter

Your appliance is equipped with a carbon filter behind a flap in the rear wall of the air distribution box.

The filter purifies the air from unwanted odours in the fridge compartment enhancing the fridge storage quality.

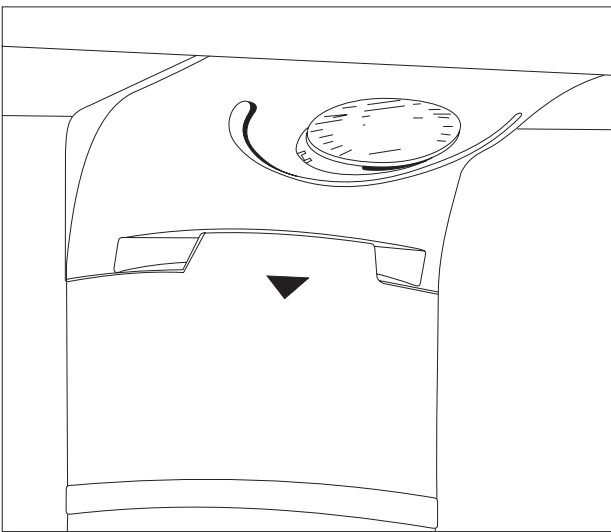

Storing foods the refrigerator

When placing different kinds of foods into the refrigerator; take note of the correct storage positions for these foods.

1. Confectionery, ready-cooked foods, foods in dishes, fresh meat, cold cuts, drinks
2. Milk, dairy products, foods in dishes
3. Fruits, vegetables, salads
4. Cheese, butter
5. Eggs
6. Yoghurt, sour cream
7. Small bottles, soft drinks
8. Big bottles, drinks
9. Fresh box

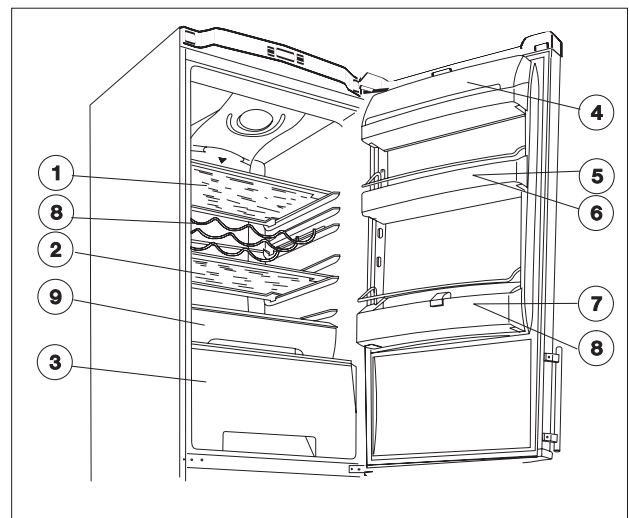

Storage time and temperature of foods

The food storage time chart in this manual gives guidelines about food storage times.

It is not possible to be precise, as the food storage time will depend on the foods freshness and how the food has been handled through the food chain.

If you do not want to place pre-frozen foods purchased from the supermarket into the freezer, they can be stored for about 1 day (until defrosted) in the refrigerator.

Using the freezer

Use of the freezer compartment

The freezer has the symbol  which means that it is suitable for freezing fresh food and for long term storage of frozen and deep-frozen food.

Storage of frozen food

When first starting-up or after a period out of use, before putting the food in the compartment let the appliance run at least 12 hours. To obtain the best performance from this appliance, you should: if large quantities of food are to be stored, remove all drawers and baskets from appliance and place food on cooling shelves.

Pay careful attention not to exceed load limit stated on the side of the upper section (where applicable).

Temperature regulation

The temperature may be set between -15°C and -24°C.

We suggest setting the internal temperature of approximately -18°C, which guarantees proper freezing and preservation of frozen foods.



Attention!

Following first start up, the temperature displayed can not correspond to the set temperature. During this time it is possible that the temperature displayed is different than the set temperature.



Attention!

Difference between the temperature displayed and temperature set is normal. Especially when:

- a new setting has recently been selected
- the door has been left open for a long time
- warm food has been placed in the compartment

Difference of up to 5°C inside the compartment are quite normal.

During normal functioning the indicator shows the warmest temperature inside the compartment.





Important

In the event of accidental defrosting, for example due to a power failure, if the power has been off for longer than the value shown in the technical characteristics chart under "rising time", the defrosted food must be consumed quickly or cooked immediately and then refrozen (after cooling).

High temperature alarm

An increase in the temperature in the freezer compartment (for example due to a power failure) is indicated by:

- flashing temperature;
- freezer compartment flashing  ;
- flashing of the icon  ;
- sounding of buzzer.

When normal conditions are restored:

- the acoustic signal shuts off;
- the temperature value continues to flash;

When you press key "E" to de-activate the alarm, the highest temperature reached in the compartment appears on indicator  for some seconds. Then it returns on the normal operation showing the temperature of the selected compartment.

During the alarm phase, the buzzer can be switched off by pressing key E.

Door open audible alarm

An audible alarm will sound when the door is left open for around 5 minutes.

The door open alarm conditions are indicated by:

- flashing symbol of the relative compartment  ;
- sounding of buzzer.

Press the key (E) to stop the acoustic alarm.

When the door is closed:

- the acoustic alarm will stop.

Freezing fresh food

The freezer compartment is suitable for long term storage of commercially frozen and deep-frozen food, and for freezing fresh food.

The maximum quantity of foods to freeze in 24 hours is shown on the rating plate

To freeze the amount of food indicated on the rating plate, place the food directly in touch with the cooling surface (remove the drawer or basket). In case the food is frozen inside the drawers or baskets, the maximum quantity is slightly reduced.

Place the food to be frozen in the  compartment, as this is the coldest part.

To freeze fresh foods, you will need to activate the quick freeze function. Press key D (several times if necessary) until the corresponding icon appears . You must confirm the choice by pressing key E within few seconds. You will hear the buzzer and the display will show the relevant icon.

After a pre-cooling period of 24 hours, place the foods in the freezer.

The freezing process takes 24 hours. During this period do not put other foods in the freezer.

This function stops automatically after 52 hours.

It is possible to de-activate the function at any time by pressing key D until the corresponding icon flashes and then pressing key E.

Storing in the freezer

Once the freezing process has been completed all compartments can be used for storage but if you require to freeze further quantities of food move the recently frozen foods to the upper compartments.

If you are storing large quantities of food you can remove the top baskets from the freezer and store foods directly on the shelves. Do not remove the bottom freezing compartment.

i For supermarket pre-frozen foods be aware of the use by date on the packaging at all times and use the foods prior to that date.

i It is not safe to re-freeze foods that were previously frozen and have defrosted; you are advised to use the foods as soon as possible or to cook the foods and then re-freeze.

How to make ice cubes

To make ice cubes fill the ice cube tray with fresh or filtered water and place the tray into the frozen food compartment. Set the thermostat control to maximum to reduce the freezing time. Re-set the thermostat control to normal running. To release the ice cubes hold the tray under running water then twist the tray.

Storage time chart (refrigerator)

Time and method of storage of fresh foods in the refrigerator

Foods	Storage time in days							Method of packaging
	1	2	3	4	5	6	7	
Raw meat	X	X	x	x	x			cling film, airtight
Cooked meat	X	X	X	x	x	x		dish covered
Roasted meat	X	X	X	x	x			dish covered
Raw minced meat	X							dish covered
Cold cuts, Vienna sausage	X	X	x	x				cling film, cellophane, grease-proof paper
Fresh fish	X	x	x					cling film, airtight
Cooked fish	X	X	x	x				dish covered
Fried fish	X	X	x	x	x			dish covered
Tinned fish, open	X	x	x					dish covered
Fresh chicken	X	X	X	x	x	x		cling film, airtight
Fried chicken	X	X	X	x	x	x		dish covered
Fresh duck, goose	X	X	X	x	x	x		cling film, airtight
Roasted duck, goose	X	X	X	X	x	x	x	dish covered
Butter unopened	X	X	X	X	X	X	X	original packaging
Butter opened	X	X	X	X	X	X	X	original packaging
Milk	X	X	X	x	x			original packaging
Cream	X	X	x	x				plastic box
Sour cream	X	X	X	X	x	x	x	plastic box
Cheese (hard)	X	X	X	X	X	X	X	aluminium foil
Cheese (soft)	X	X	X	X	x	x	x	cling film
Curds	X	X	X	X	x	x	x	cling film
Egg	X	X	X	X	X	X	X	
Spinach, sorrel	X	X	x	x				cling film
Green peas, green beans	X	X	X	X	x	x	x	cling film
Mushroom	X	X	x	x	x			cling film
Carrot, roots	X	X	X	X	X	X	X	cling film
Bell-pepper	X	X	x	x	x			cling film
Tomato	X	X	X	X	X	X	X	cling film
Cabbage	X	X	X	X	X	x	x	cling film
Soft fruits (strawberries, raspberries, etc.)	X	X	X	x	x			cling film
Other fruits	X	X	X	X	x	x	x	cling film
Tinned fruits opened	X	X	X	x	x			dish covered
Cakes filled with cream	X	X	x	x				dish covered

Notation:

X usual storage time

x possible storage time (concerns to really fresh product only)

Storage time chart (freezer)

Storage time of deep-frozen and frozen products

Foods	In the fresh food compartment +2 - +7°C	In the **** frozen food compartment -18°C
Vegetables: green beans, green peas, mixed vegetables, marrow, corn, etc.	1 day	12 months
Ready-cooked foods: vegetable dish, trimmings, with meat, etc.	1 day	12 months
Ready-cooked foods: sirloin steaks,	1 day	6 months
Foods from potatoes, pasta: mashed potato, gnocchi, dumplings, filled pasta	1 day	12 months
Soups: vegetable soup	1 day	6 months
Fruits: cherries	1 day	12 months
Meat: chicken, duck, goose fillets, tuna fish	1 day 1 day	5 months 6 months
Ice-cream	1 day	3 weeks

Maintenance and Cleaning

 You must disconnect the appliance from the electricity supply, before you can carry out any cleaning or maintenance work.

Defrosting

Defrosting is automatic in this appliance.

Regular cleaning

Disconnect the appliance from the electricity supply, before you carry out any cleaning or maintenance work.

Clean the equipment regularly.

 **Do not use detergents, abrasive or strongly odorous cleaners, waxy polishing agents, disinfectants or alcoholic products for cleaning the equipment.**

Pull out the wall plug of the equipment from the outlet.

Internal cleaning

Clean the internal parts of the equipment and the accessories with warm water and Bicarbonate of Soda (5 ml to 0.5 litre of water).

Rinse and dry everything thoroughly.

Clean the door seal with clean water.

External cleaning

Clean the external parts of the equipment with warm water and Bicarbonate of Soda (5 ml to 0.5 litre of water).

Dust will build up on the condenser (the black grill at the back of the appliance) and the reservoir; this can inhibit the efficiency of the fridge freezer. It is recommended to clean both on a six monthly basis.

After cleaning, reconnect the equipment to the mains supply.

Changing the Carbon Filter

To maintain the best performance the carbon filter should be changed every year.

New carbon filters can be purchased from your local dealer.

1. Pull the flap outwards. (1)
2. Remove the filter from the plastic bag.
3. Insert the filter in the slot found in the back of the flap cover (2).
4. Close the flap cover.

Note: the carbon filter is a consumable accessory and as such is not covered by the guarantee.

 **During operation, always keep the air ventilation flap closed.**

 **The filter should be handled carefully so fragments do not loosen from the surface.**

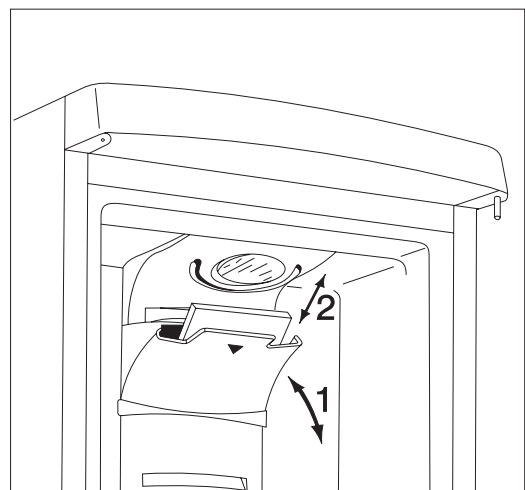

When the refrigerator is not in use

If the refrigerator is to be turned off for some time, follow these steps.

Unplug the appliance.

Remove foods from the refrigerator.

Defrost and clean it as written before.

Defrost and clean as detailed above.

Trouble shooting

How to change the bulb

Should the light fail to work you can change it as below:

Break the circuit of the appliance.

Press the rear hook (1) of the lampcover by a screwdriver and at the same time pull and rotate the cover in the direction indicated by the arrow (2). So the bulb can be replaced. (Bulb type: T25 Daylight Halolux 230-240 V, 25 W, E 14 thread)

After changing the bulb replace the cover, snap it in place and apply voltage to the appliance.

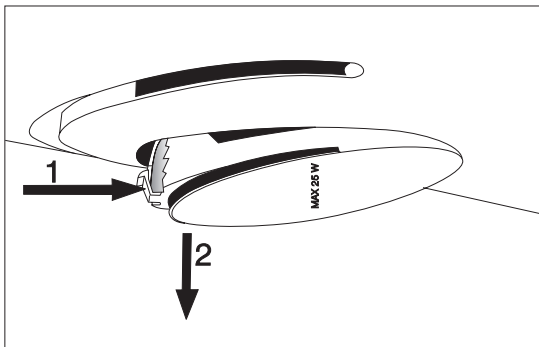

Something Not Working

Certain problems are due to a lack of simple maintenance or oversights, which can be solved easily without calling out an engineer. Please carry out the following checks before contacting the extended warranty administrators see Repairs - After Sales Service.

IMPORTANT: If you call out an engineer to a fault listed below, or to repair a fault caused by incorrect use or installation, a charge will be made even if the appliance is under guarantee.

Symptom	Cause	Solution
<ul style="list-style-type: none"> It is too warm in the refrigerator. 	<ul style="list-style-type: none"> If products are not cold enough or placed incorrectly. The door does not close tightly or it is not shut properly. 	<ul style="list-style-type: none"> Place the products to the appropriate place. Check if the door closes well and the gasket is undamaged and clean.
<ul style="list-style-type: none"> It is too warm in the freezer. 	<ul style="list-style-type: none"> The door does not close tightly or it is not shut properly. Products in big quantity to be frozen were put in. Products to be frozen are placed too closely to each other. 	<ul style="list-style-type: none"> Check if the door closes well and the gasket is undamaged and clean. Wait some hours and then check the temperature again. Place the products in a way so that cold air could circulate among them.
<ul style="list-style-type: none"> Water flows onto the floor. 	<ul style="list-style-type: none"> The melting water outlet flows not into the evaporative tray above the compressor. 	<ul style="list-style-type: none"> Put the melting water outlet to the evaporative tray.
<ul style="list-style-type: none"> There are too much frost and ice. 	<ul style="list-style-type: none"> Products are not wrapped properly. Doors are not shut properly or do not close tightly. The thermostatic control can be set incorrectly. 	<ul style="list-style-type: none"> Wrap the products better. Check if the doors close well and the gaskets are undamaged and clean. Set the thermostat a position that gives higher temperature.
<ul style="list-style-type: none"> The compressor operates continually. 	<ul style="list-style-type: none"> Doors are not shut properly or do not close tightly. Products in big quantity to be frozen were put in. Too warm food was put in. The appliance is in too warm place. 	<ul style="list-style-type: none"> Check if the doors close well and the gaskets are undamaged and clean. Wait some hours and then check the temperature again. Put food at max. room temperature. Try to reduce the temperature in the room where the appliance stands.
<ul style="list-style-type: none"> The appliance does not work at all. Neither cooling, nor lighting works. 	<ul style="list-style-type: none"> Plug is not connected to the mains socket properly. The fuse burnt out. The thermostatic control is not on. There is no voltage in the mains socket. (Try to connect another appliance into it.) 	<ul style="list-style-type: none"> Connect the mains plug properly. Change the fuse. Start the appliance according to instructions in chapter 'Installation'. Call an electrician.
<ul style="list-style-type: none"> The appliance is noisy. 	<ul style="list-style-type: none"> The appliance is not supported properly. 	<ul style="list-style-type: none"> Check if the appliance stands stable (all the four feet should be on the floor).

In as much as the advice does not lead to result, call the nearest brand-mark service.

Repairs - After Sales Service

In the unlikely event of your appliance requiring service, or if you wish to purchase spare parts, please contact our extended warranty administrators by telephoning:

0870 010 7887

They will give you details for your local Service Force Centre.

Before calling out an engineer, please ensure you have read the details under the heading "Something Not Working".

When you contact your local Service Force Centre you will need to give the following details:

1. Your name, address and post code
2. Your telephone number
3. Clear and concise details of fault
4. The purchase date found on your receipt
5. The model and serial number of the appliance (found on the rating plate - see picture on page 5)

So that you always have these numbers at hand, we recommend you to make a note of them here:

Mod. :

PNC :

S.N. :

Your Fridge - Freezer is covered by a 3 year parts and labour guarantee (see separate details given at point of sale). Please retain your purchase receipt safely for the service engineer to verify the purchase details.

Spare parts

Always insist on genuine spare parts.

An authorised service engineer should service this product, and only genuine spare parts should be used.

Under no circumstances should you attempt to repair the machine yourself. Repairs carried out by inexperienced persons may cause injury or serious malfunctioning. Contact your local Service Force Centre.

John Lewis Partnership
171 Victoria Street
London SW1E 5NN

www.johnlewis.com

Free Manuals Download Website

<http://myh66.com>

<http://usermanuals.us>

<http://www.somanuals.com>

<http://www.4manuals.cc>

<http://www.manual-lib.com>

<http://www.404manual.com>

<http://www.luxmanual.com>

<http://aubethermostatmanual.com>

Golf course search by state

<http://golfingnear.com>

Email search by domain

<http://emailbydomain.com>

Auto manuals search

<http://auto.somanuals.com>

TV manuals search

<http://tv.somanuals.com>