

John Lewis JL3/80-W
John Lewis JL3/110-W

Flat-screen television stand

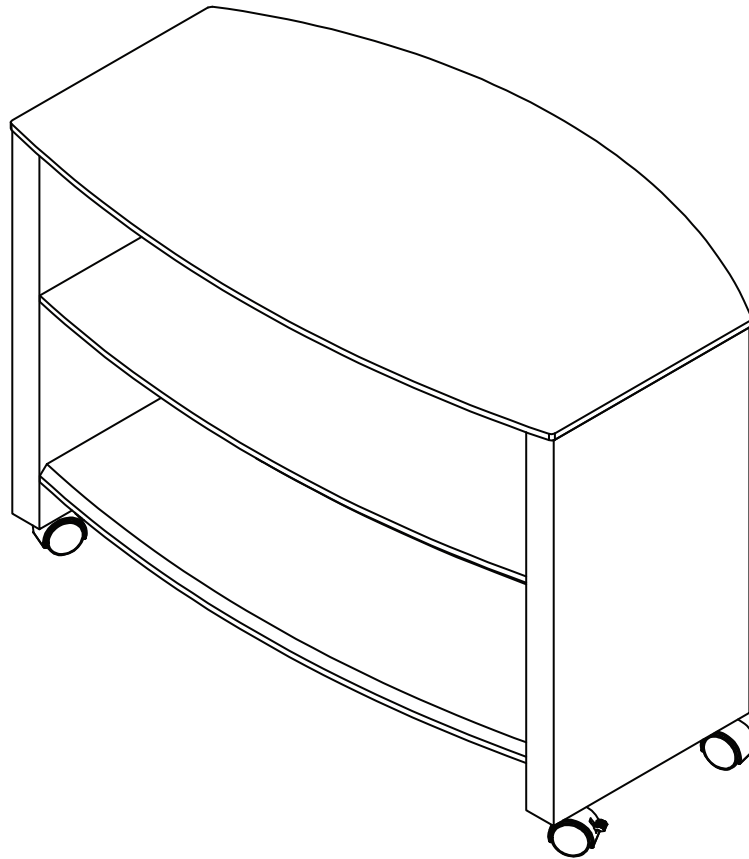



Instruction manual



John Lewis

Thank you for purchasing this flat-screen television stand. Please read the instructions carefully to ensure safe and satisfactory operation of this product. Retain this information for future reference.

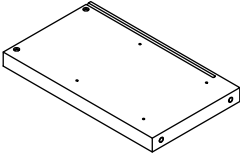
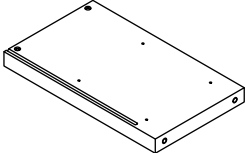
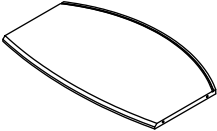
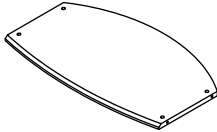
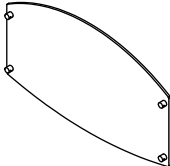
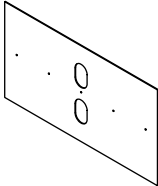
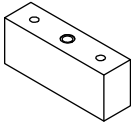
WARNING!

- Before starting this assembly please take time to familiarise yourself with the components listed below.
- Do not place very hot or very cold items against or in close proximity to glass surfaces unless an adequately thick insulating material is used to prevent such items coming into contact with the glass.
- Do not strike the glass with hard or pointed items.
- When cleaning glass panels use a damp cloth or leather with washing up liquid or soft soap if necessary; do not use washing powders or any other substance containing abrasives as these substances scratch glass.
- Do not sit or stand upon horizontal glass surfaces.
- **Maximum safe load for top glass shelf is JL3/80-W: 70kg, JL3/110-W: 50kg**
- **Maximum safe load for lower shelves is 20kg.**

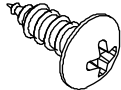
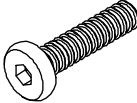
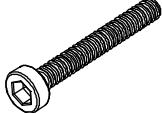
Component		Description	Qty	Packed by
	a	Left hand leg	1	
	b	Right hand leg	1	
	c	Bottom shelf	1	
	d	Middle shelf	1	
	e	Top glass shelf	1	
	f	Back panel	1	
	g	Rear leg	1	
	h	Metal dowel	8	
	j	Metal Cam	8	

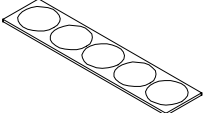
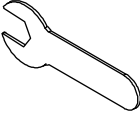
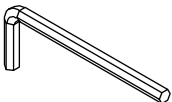
Component	Description	Qty	Packed by
	k	Fixing screw	5
	m	Short fixing bolt	4
	n	Long fixing bolt	2
	o	Swivel castor (braked)	2
	p	Swivel castor	3
	q	Self adhesive pads	5
	r	Spanner	1
	s	Allen key	1

Stage 1

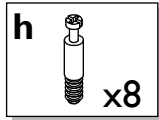
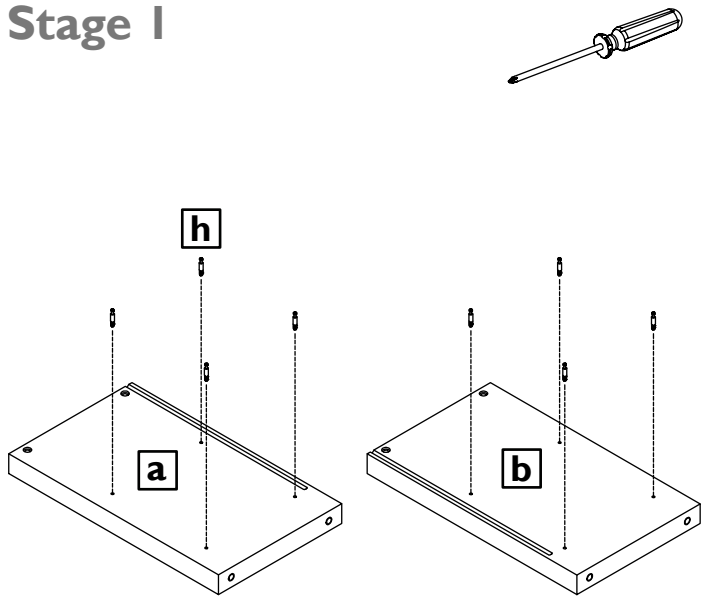

- Screw metal dowels **h** into legs **a** and **b**

Stage 2

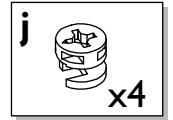
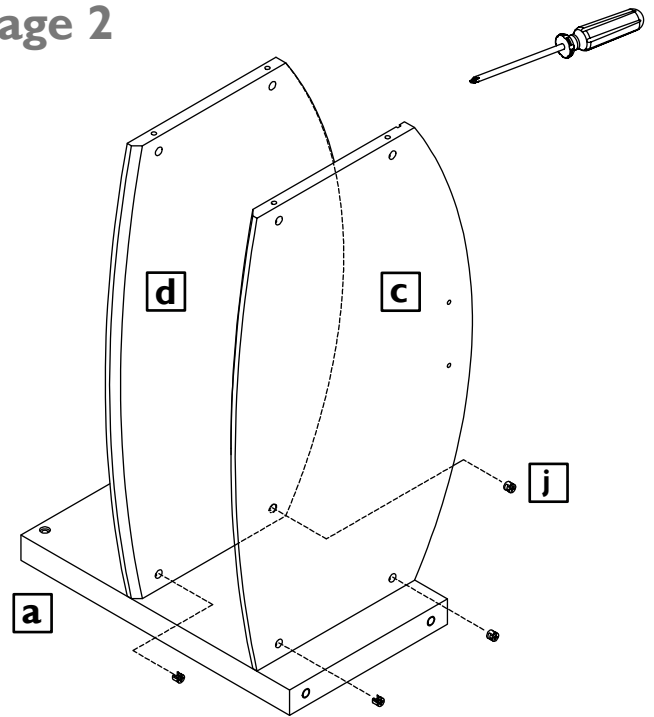

- Position shelves **c** and **d** onto metal dowels.
- Insert metal cams **j** into holes in shelves **c** and **d**. Using a screwdriver tighten the cams in a clockwise direction.

Stage 3

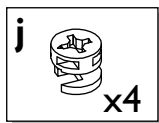
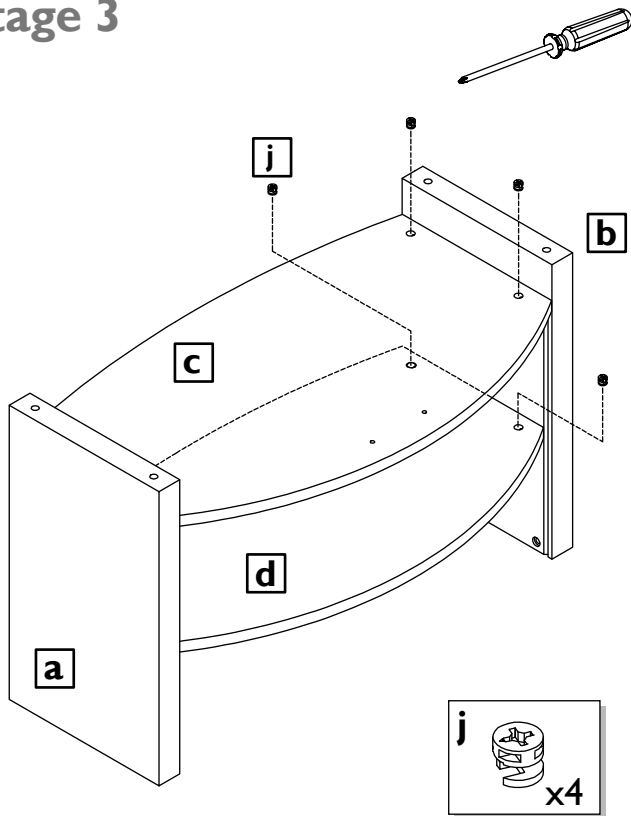

- Position shelves **c** and **d** onto metal dowels.
- Insert metal cams **j** into holes in shelves **c** and **d**. Using a screwdriver tighten the cams in a clockwise direction.

Stage 4

Turn the stand over as shown

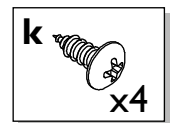
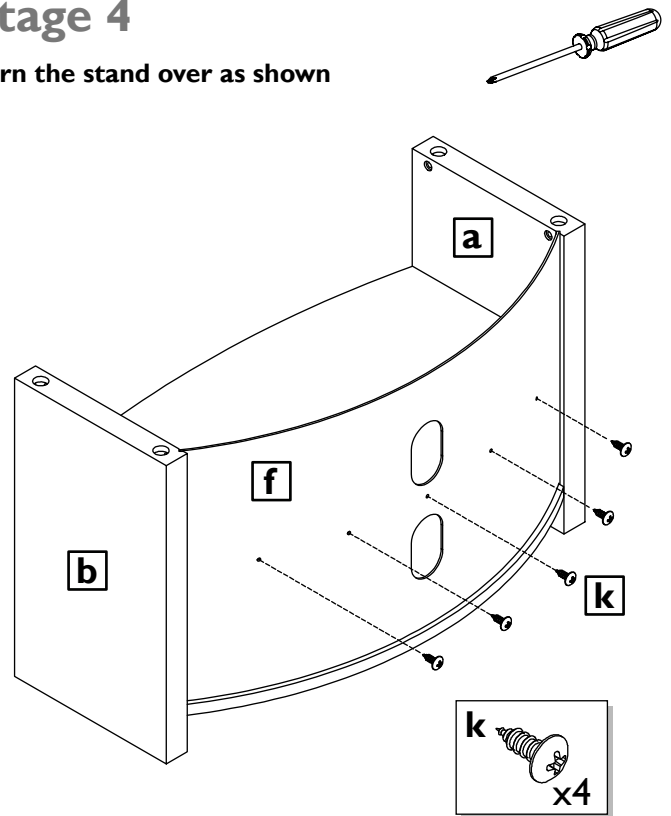

- Bend and slide the back panel **f** into the grooves on the legs and base.
- Secure the back panel in position with fixing screws **k**

Stage 5

Place the glass top **e** on a rug or carpet for protection.
Turn the stand over as shown.

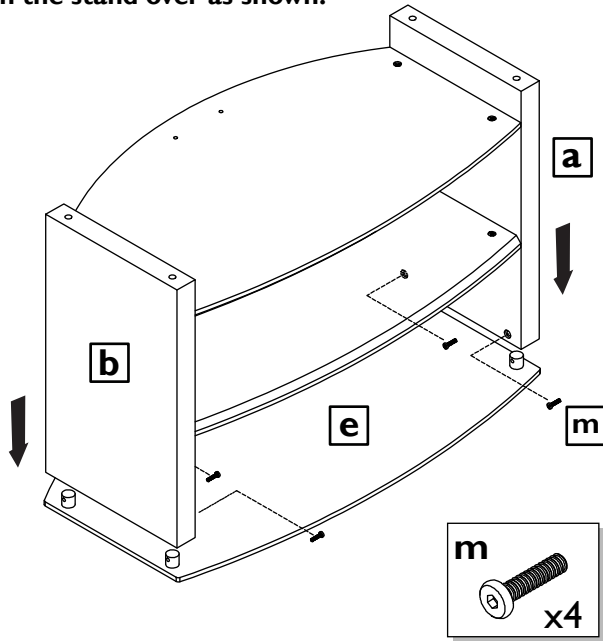

- Position legs **a** and **b** onto metal bosses as shown.
- Insert fixing bolts **m** and secure with allen key **s**

Stage 6

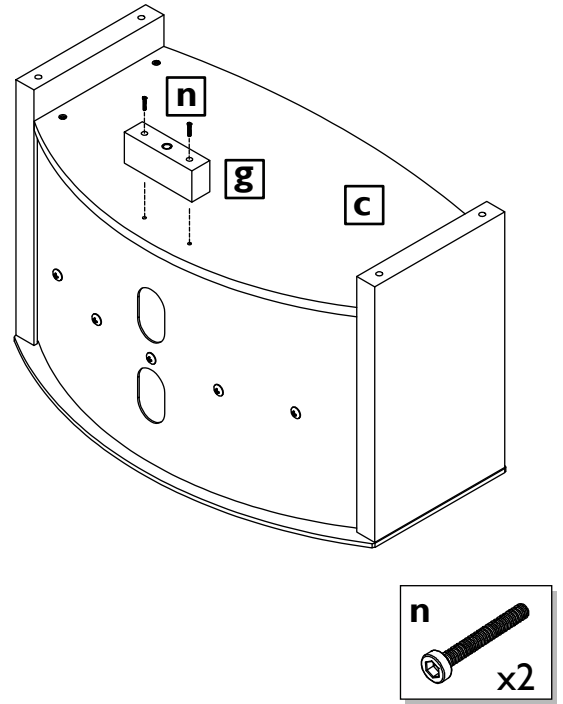

- Place rear leg **g** on bottom shelf **c**
- Insert fixing bolts **n** and secure with allen key **s**

Stage 7 (optional)

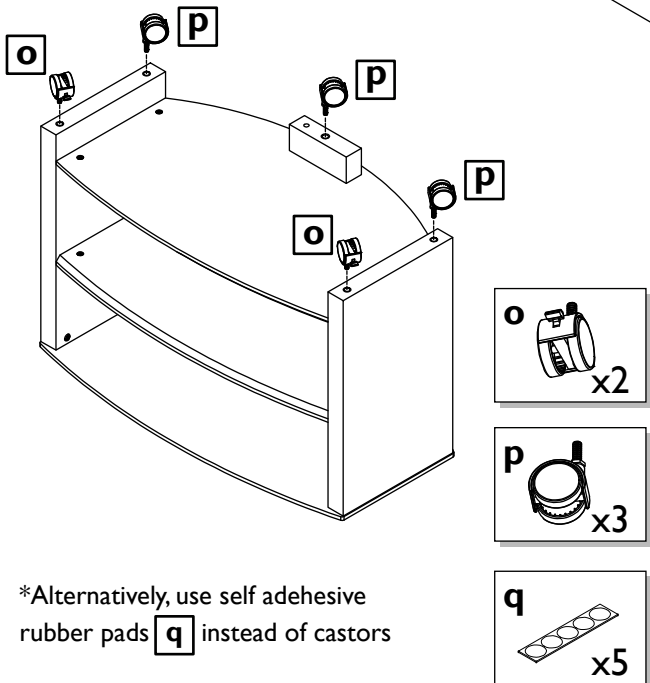

*Alternatively, use self adhesive rubber pads **q** instead of castors

- Insert castors **o** and **p** into holes in legs **a** and **b**
Using spanner **r** secure the castors in position.

Stage 8

Turn the finished stand over as shown

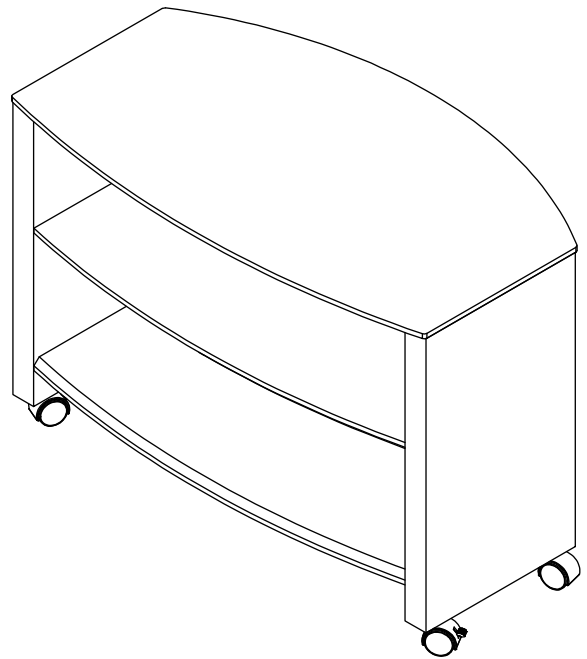

Free Manuals Download Website

<http://myh66.com>

<http://usermanuals.us>

<http://www.somanuals.com>

<http://www.4manuals.cc>

<http://www.manual-lib.com>

<http://www.404manual.com>

<http://www.luxmanual.com>

<http://aubethermostatmanual.com>

Golf course search by state

<http://golfingnear.com>

Email search by domain

<http://emailbydomain.com>

Auto manuals search

<http://auto.somanuals.com>

TV manuals search

<http://tv.somanuals.com>