

# INSTALLATION MANUAL

## AFFINITY™ SERIES SINGLE PACKAGED GAS/ELECTRIC AIR COOLED AIR CONDITIONERS 1.5 THROUGH 5 NOMINAL TON

### CONTENTS

GENERAL.....	3
INSPECTION .....	3
RENEWAL PARTS.....	3
APPROVALS .....	3
INSTALLATION .....	4
SEQUENCE OF OPERATION .....	13
START-UP .....	15
TYPICAL WIRING DIAGRAM NOTES.....	23

See the following page for a complete Table of Contents.

### NOTES, CAUTIONS AND WARNINGS

The installer should pay particular attention to the words: *NOTE*, *CAUTION*, and *WARNING*. *Notes* are intended to clarify or make the installation easier. *Cautions* are given to prevent equipment damage. *Warnings* are given to alert installer that personal injury and/or equipment damage may result if installation procedure is not handled properly.

**CAUTION: READ ALL SAFETY GUIDES BEFORE YOU BEGIN TO INSTALL YOUR UNIT.**

DNA: 018      042  
024      048  
030      060  
036

### EXPORT

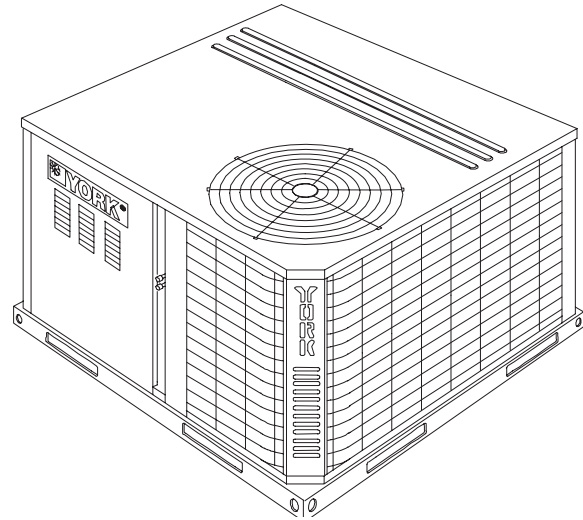

ISO 9001  
Certified Quality  
Management System

SAVE THIS MANUAL

## TABLE OF CONTENTS

<b>GENERAL</b> .....	<b>3</b>
<b>INSPECTION</b> .....	<b>3</b>
<b>RENEWAL PARTS</b> .....	<b>3</b>
<b>APPROVALS</b> .....	<b>3</b>
<b>INSTALLATION</b> .....	<b>4</b>
LIMITATIONS .....	4
LOCATION .....	4
RIGGING OR HANDLING .....	4
CLEARANCES .....	5
DUCT WORK .....	5
ROOF CURB .....	5
FILTERS .....	5
CONDENSATE DRAIN .....	5
SERVICE ACCESS .....	6
THERMOSTAT .....	6
POWER AND CONTROL WIRING .....	6
COMPRESSORS .....	6
GAS PIPING .....	8
GAS CONNECTION .....	8
FLUE VENT HOOD .....	9
<b>SEQUENCE OF OPERATION</b> .....	<b>13</b>
HEATING .....	13
PRESSURE SWITCH PROVING .....	13
PRE-PURGE .....	13
IGNITION TRIAL PERIOD .....	13
PILOT FLAME STABILIZATION PERIOD .....	13
HEAT BLOWER ON DELAY .....	13
MAIN BURNER OPERATION .....	13
POST PURGE .....	14
HEAT BLOWER OFF DELAY .....	14
LOCKOUT .....	14
HIGH TEMPERATURE LIMIT SWITCH .....	14
ROLLOUT SWITCH .....	14
POWER INTERRUPTIONS .....	14
FLAME PRESENT WITH GAS OFF .....	14
GAS VALVE STUCK OPEN OR CLOSED .....	14
FLAME SENSE CIRCUIT FAILURE .....	14
SAFETY CONTROLS .....	14
COOLING .....	15
CIRCULATING FAN .....	15
<b>START-UP</b> .....	<b>15</b>
PRE-START CHECK LIST .....	15
OPERATING INSTRUCTIONS .....	15
TO TURN OFF GAS TO UNIT .....	15
POST-START CHECK LIST (GAS) .....	16
MANIFOLD GAS PRESSURE ADJUSTMENT .....	16
BURNER INSTRUCTIONS .....	16
PILOT INSTRUCTIONS .....	16
ADJUSTMENT OF TEMPERATURE RISE .....	17
DIRECT DRIVE BLOWER .....	17
CHECKING GAS INPUT .....	17
NATURAL GAS .....	17
CHECKING SUPPLY AIR CFM .....	18
<b>TYPICAL WIRING DIAGRAM NOTES</b> .....	<b>23</b>

## LIST OF FIGURES

<u>Fig. #</u>		<u>Pg. #</u>
1	PRODUCT NOMENCLATURE .....	3
2	UNIT CENTER OF GRAVITY .....	5
3	TYPICAL FIELD CONTROL WIRING DIAGRAM ..	6
4	TYPICAL FIELD POWER WIRING DIAGRAM ....	6
5	EXTERNAL SUPPLY CONNECTION EXTERNAL SHUT-OFF .....	8
6	FLUE VENT OUTLET AIR HOOD .....	9
7	UNIT DIMENSIONS - FRONT .....	11
8	UNIT DIMENSIONS - FRONT & BOTTOM .....	12
9	UNIT DIMENSIONS - BACK & BOTTOM .....	12
10	GAS VALVE - FRONT .....	16
11	GAS VALVE - REAR .....	16
12	PROPER FLAME ADJUSTMENT .....	17
13	DNA COIL DELTA P VS. AIRFLOW .....	19
14	TYPICAL WIRING DIAGRAM DNA 018 THRU 060 (208/230-1-60 POWER SUPPLY) .....	22
15	TYPICAL WIRING DIAGRAM LEGEND .....	23

## LIST OF TABLES

<u>Tbl. #</u>		<u>Pg. #</u>
1	UNIT APPLICATION DATA .....	4
2	UNIT WEIGHTS AND CENTER OF GRAVITY .....	5
3	NATURAL GAS APPLICATION DATA .....	7
4	PROPANE (LP) GAS APPLICATION DATA .....	7
5	NATURAL GAS PIPE SIZING CHART .....	8
6	PROPANE (LP) GAS PIPE SIZING CHART .....	8
7	PHYSICAL DATA .....	10
8	ELECTRICAL DATA .....	10
9	UNIT DIMENSIONS FRONT .....	11
10	UNIT MINIMUM CLEARANCES .....	11
11	IGNITION CONTROL BOARD FLASH CODES .....	15
12	GASE RATE - CUBIC FEET PER HOUR .....	18
13	SUPERHEAT CHARGING TABLE FOR DNA018 .....	19
14	SUPERHEAT CHARGING TABLE FOR DNA024 .....	20
15	SUPERHEAT CHARGING TABLE FOR DNA030 .....	20
16	SUPERHEAT CHARGING TABLE FOR DNA036 .....	20
17	SUPERHEAT CHARGING TABLE FOR DNA042 .....	21
18	SUPERHEAT CHARGING TABLE FOR DNA048 .....	21
19	SUPERHEAT CHARGING TABLE FOR DNA060 .....	21

## GENERAL

YORK Model DNA units are cooling/heating air conditioners designed for outdoor installation. Only gas piping, electric power and duct connections are required at the point of installation.

The gas-fired heaters have spark to pilot ignition. The tubular heat exchangers are aluminized steel.

This appliance is not to be used for temporary heating of buildings or structures under construction.

Installer should pay particular attention to the words; NOTE, CAUTION, and WARNING. NOTES are intended to clarify or make the installation easier. CAUTIONS are given to prevent equipment damage. WARNINGS are given to alert the installer that personal injury and/or equipment damage may result if installation procedure is not handled properly.

## INSPECTION

As soon as a unit is received, it should be inspected for possible damage during transit. If damage is evident, the extent of the damage should be noted on the carrier's freight bill. A separate request for inspection by the carrier's agent should be made in writing.

## RENEWAL PARTS

Contact your local York® parts distribution center for authorized replacement parts.

## APPROVALS

Design certified by CGA and AGA listed as follows:

1. For use as a forced air furnace with cooling unit.
2. For outdoor installation only.
3. For installation directly on combustible flooring or, in U.S., on wood flooring or Class A; B; C roof covering material.
4. For installation on combustible material.
5. For use with natural gas and/or propane (LP) gas. Not suitable for use with conventional venting systems.

**⚠ CAUTION**

This product must be installed in strict compliance with the enclosed installation instructions and any applicable local, state, and national codes including, but not limited to, building, electrical and mechanical codes.

**⚠ WARNING**

Improper installation may create a condition where the operation of the product could cause personal injury or property damage.

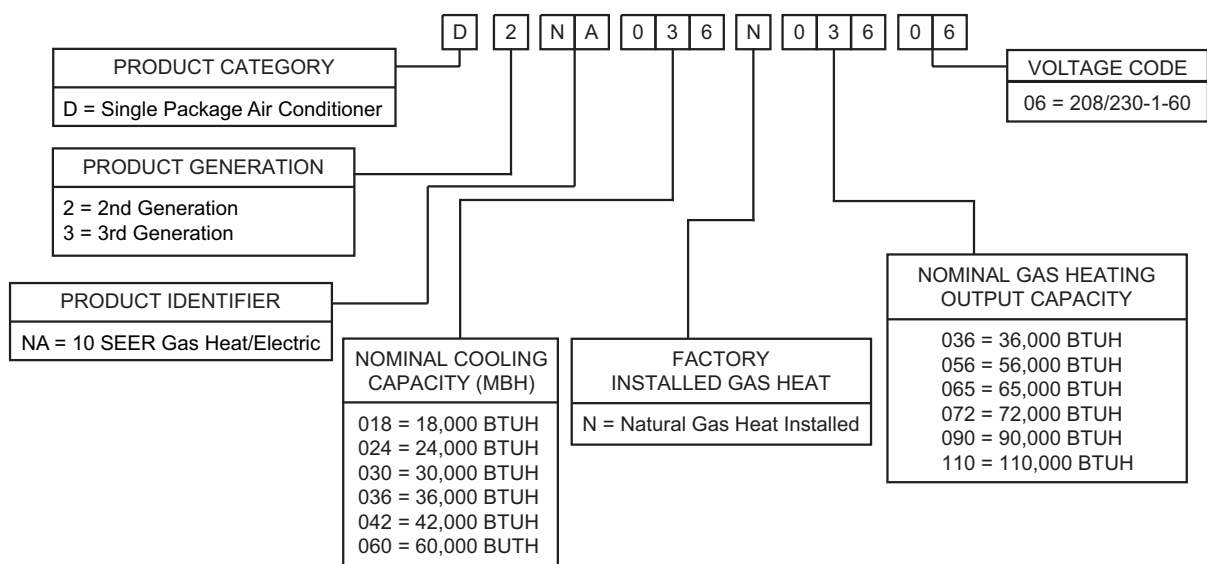

FIGURE 1 - PRODUCT NOMENCLATURE

## INSTALLATION

### LIMITATIONS

These units must be installed in accordance with the following national and local safety codes.

1. National Electrical Code ANSI/NFPA No. 70 or Canadian Electrical Code Part 1, C22.1 (latest editions).
2. National Fuel Gas Code Z223.1 or CAN/CGA B149.1 or 2 Installation Code.
3. Local gas utility requirements.
4. Local plumbing and waste water codes and other applicable local codes.

Refer to Table 1 for unit application data and to Table 2 for gas heat application data.

If components are to be added to a unit to meet local codes, they are to be installed at the dealer's and/or the customer's expense.

Size of unit for proposed installation should be based on heat loss/heat gain calculations made in accordance with industry recognized procedures identified by the Air Conditioning Contractors of America.

**TABLE 1: UNIT APPLICATION DATA**

Voltage Variation Min. / Max. <sup>1</sup>	208/230V <sup>2</sup>	187 / 253
Wet Bulb Temperature (°F) of Air on Evaporator Coil, Min. / Max.		57 / 72
Dry Bulb Temperature (°F) of Air on Condenser Coil, Min. <sup>3</sup> / Max.		45 / 120

1. Rated in accordance with ARI Standard 110, utilization range "A".
2. "T1" transformer primary tap must be moved from the 230 volt connection to the 208 volt connection for low voltage applications of 208 volt and below
3. A low ambient accessory is available for operation down to 0 °F.

### LOCATION

Use the following guidelines to select a suitable location for these units.

1. Unit is designed for outdoor installation only.
2. Condenser must have an unlimited supply of air. Where a choice of location is possible, position unit on either north or east side of building.

### CAUTION

Excessive exposure of this furnace to contaminated combustion air may result in equipment damage or personal injury. Typical contaminants include: permanent wave solution, chlorinated wastes and cleaners, chlorine based swimming pool chemicals, water softening chemicals, carbon tetrachloride, halogen type refrigerants, cleaning solvents (e.g. perchloroethylene), printing inks, paint removers, varnishes, hydrochloric acid, cements and glues, antistatic fabric softeners for clothes dryers, masonry acid washing materials.

3. For ground level installation, a level pad or slab should be used. The thickness and size of the pad or slab used should meet local codes and unit weight. Do not tie the slab to the building foundation.
4. For roof top installation, be sure the structure will support the weight of the unit plus any field installed components. Unit must be installed on a level roof curb or appropriate angle iron frame providing adequate support under the compressor/condenser section.
5. Maintain level tolerance of unit to 1/8" maximum.

### RIGGING OR HANDLING

Care must be exercised when moving the unit. Do not remove any packaging until the unit is near the place of installation. Rig unit with slings placed under the unit. Spreader bars of sufficient length should be used across the top of the unit.

### WARNING

Before lifting a unit, make sure that its weight is distributed equally on the cables so that it will lift evenly.

Units may also be moved or lifted with a fork-lift. Slotted openings in the skid are provided for this purpose. Forks must pass completely through the base.

Refer to Table 2 for unit weights and to Figure 2 for approximate center of gravity.

**TABLE 2: UNIT WEIGHTS AND CENTER OF GRAVITY**

UNIT SIZE	SHIPPING WEIGHT (LBS.)	OPERATING WEIGHT (LBS.)	CORNER WEIGHTS (LOCATION, LBS.)			
			"A"	"B"	"C"	"D"
018	365	360	91	88	89	92
024	365	360	91	88	89	92
030	395	390	98	95	96	99
036	400	395	100	96	98	101
042	415	410	104	100	101	105
048	475	470	119	115	116	120
060	480	475	120	116	117	122

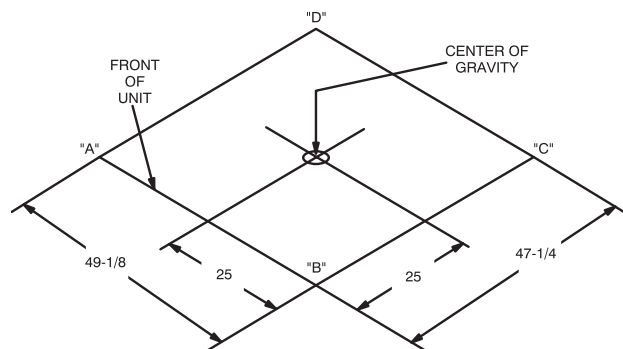

**FIGURE 2 - UNIT CENTER OF GRAVITY**

**CLEARANCES**

All units require certain clearances for proper operation and service. Refer to Table 10 for the clearances required for combustion, construction, servicing and proper unit operation.

<b>▲ WARNING</b>
Do not permit overhanging structures or shrubs to obstruct the condenser air discharge, combustion air inlet or vent outlet.

**DUCT WORK**

These units are adaptable to downflow use as well as rear supply and return air duct openings. To convert to downflow, use the following steps:

1. Remove the duct covers found in the bottom return and supply air duct openings. There are four (4) screws securing each duct cover (save these screws to use later).

2. Install the duct covers, removed in step one, to the rear supply and return air duct openings. Secure with the four (4) screws used in step one.
3. Seal duct covers with silicone caulk.

Duct work should be designed and sized according to the methods of the Air Conditioning Contractors of America (ACCA), as set forth in their Manual D.

A closed return duct system shall be used. This shall not preclude use of economizers or ventilation air intake. Flexible joints may be used in the supply and return duct work to minimize the transmission of noise.

<b>▲ CAUTION</b>
When fastening duct work to the side duct flanges on the unit, insert the screws through the duct flanges only. Do not insert the screws through the casing. Outdoor ductwork must be insulated and waterproofed.

**NOTE:** Be sure to note supply and return openings.

Refer to Figure 9 for information concerning rear and bottom supply and return air duct openings.

**ROOF CURB**

On applications when a roof curb is used, the unit must be positioned on the curb so the front of the unit is tight against the curb.

**FILTERS**

Single phase units are shipped without a filter and is the responsibility of the installer to secure a filter in the return air ductwork or install a Filter/Frame Kit (1FF0110 for the DNA018 thru DNA042 and 1FF0112 for the DNA048 and DNA060).

Filters must always be used and must be kept clean. When filters become dirt laden, insufficient air will be delivered by the blower, decreasing your units efficiency and increasing operating costs and wear-and-tear on the unit and controls.

Filters should be checked monthly especially since this unit is used for both heating and cooling.

**CONDENSATE DRAIN**

A condensate trap is recommended to be installed in the condensate drain. The plumbing must conform to local codes. Use a sealing compound on male pipe threads. Install the condensate drain line (NPTF) to spill into an open drain.

### SERVICE ACCESS

Access to all serviceable components is provided by the following removable panels:

- Blower compartment
- Gas control/electrical service access

Refer to Figure 7 for location of these access panels and minimum clearances.

### THERMOSTAT

The room thermostat should be located on an inside wall approximately 56" above the floor where it will not be subject to drafts, sun exposure or heat from electrical fixtures or appliances. Follow manufacturer's instructions enclosed with the thermostat for general installation procedure. Four color coded insulated wires (minimum #18 AWG) should be used to connect thermostat to unit. See Figure 3.

### POWER AND CONTROL WIRING

Field wiring to the unit must conform to provisions of the current N.E.C. ANSI/NFPA No. 70 or C.E.C. and/or local ordi-

nances. The unit must be electrically grounded in accordance with local codes or, in their absence, with the N.E.C./C.E.C. Voltage tolerances which must be maintained at the compressor terminals during starting and running conditions are indicated on the unit Rating Plate and Table 8.

The wiring entering the cabinet must be provided with mechanical strain relief.

A fused disconnect switch should be field provided for the unit. If any of the wire supplied with the unit must be replaced, replacement wire must be of the type shown on the wiring diagram.

Electrical line must be sized properly to carry the load. Each unit must be wired with a separate branch circuit fed directly from the meter panel and properly fused.

Refer to Figure 4 for typical field wiring and to the appropriate unit wiring diagram for control circuit and power wiring information.

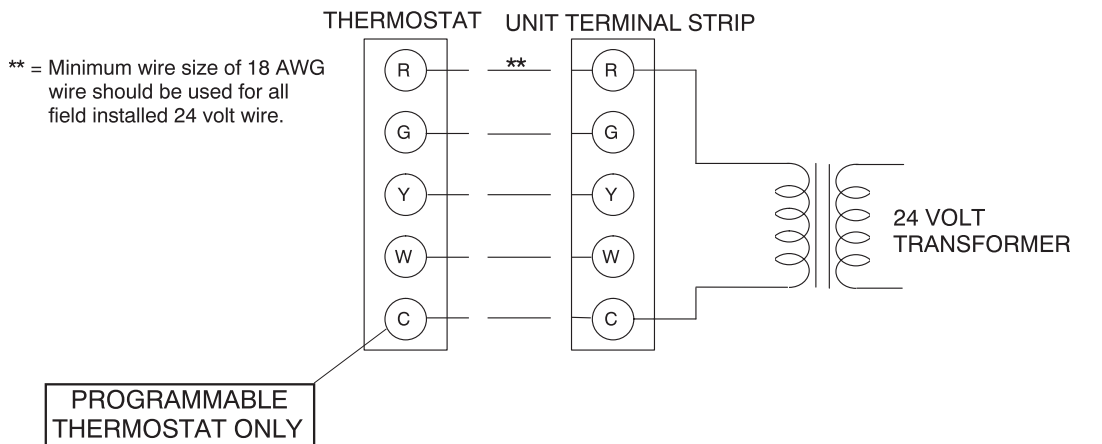

FIGURE 3 - TYPICAL FIELD CONTROL WIRING DIAGRAM

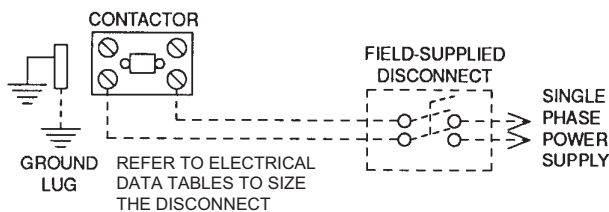

FIGURE 4 - TYPICAL FIELD POWER WIRING DIAGRAM

### COMPRESSORS

Units are shipped with compressor mounting factory-adjusted for shipping.

**CAUTION**

Loosen compressor mounting bolts a half turn before operating unit.

**TABLE 3: NATURAL GAS APPLICATION DATA**

AVAILABLE ON MODELS	INPUT (MBH) <sup>1</sup>	OUTPUT (MBH)	GAS RATE <sup>2</sup> FT. <sup>3</sup> /HR.	NUMBER OF BURNERS	TEMP. RISE °F AT FULL INPUT <sup>3</sup>	
					MIN.	MAX.
1 1/2, 2, 2-1/2, 3, 3-1/2 TON	45	36	42	2	25	55
2, 2-1/2	70	56	65	3	30	60
3, 3-1/2 TON	70	56	65	3	25	55
4, 5 TON	80	64	74	3	25	55
3, 3-1/2 TON	90	72	84	4	30	60
4, 5 TON	108	87	100	4	35	65
4, 5 TON	135	108	126	5	45	75

1. Heating capacity valid for elevations up to 2000 feet above sea level. For elevations above 2,000 feet, rated capacity should be reduced by 4% for each 1,000 feet above sea level.
2. Based on 1075 BTU/Ft.<sup>3</sup>.
3. The air flow must be adjusted to obtain a temperature rise within the range shown. Continuous return air temperature should not be below 55°F.

**TABLE 4: PROPANE<sup>1</sup> (LP) GAS APPLICATION DATA**

AVAILABLE ON MODELS	INPUT (MBH) <sup>2</sup>	OUTPUT (MBH)	GAS RATE <sup>3</sup> FT. <sup>3</sup> /HR.	NUMBER OF BURNERS	TEMP. RISE °F AT FULL INPUT <sup>4</sup>	
					MIN.	MAX.
1 1/2, 2, 2-1/2, 3, 3-1/2 TON	45	36	18	2	25	55
2, 2-1/2	70	56	28	3	30	60
3, 3-1/2 TON	70	56	28	3	25	55
4, 5 TON	80	64	32	3	25	55
3, 3-1/2 TON	90	72	36	4	30	60
4, 5 TON	108	87	43	4	35	65
4, 5 TON	135	108	54	5	45	75

1. Propane applications are accomplished by field installation of a Propane Conversion Accessory, Model 1NP0807 for 1-1/2 thru 3-1/2 ton units with 33-1/2" tall cabinets and Model 1NP0808 for 4 and 5 ton units with 41-1/2" tall cabinets.
2. Heating capacity valid for elevations up to 2,000 feet above sea level. For elevations above 2,000 feet, rated capacity should be reduced by 4% for each 1,000 feet above sea level.
3. Based on 2500 BTU/Ft.<sup>3</sup>.
4. The air flow must be adjusted to obtain a temperature rise within the range shown. Continuous return air temperatures should not be below 55°F.

**GAS PIPING**

Proper sizing of gas piping depends on the cubic feet per hour of gas flow required, specific gravity of the gas and the length of run. National Fuel Gas Code Z223.1 or CAN/CGA B149.1 or .2 should be followed in all cases unless superseded by local codes or gas company requirements. Refer to Tables 5 and 6.

The heating value of the gas may differ with locality. The value should be checked with the local gas utility.

**NOTE:** There may be a local gas utility requirement specifying a minimum diameter for gas piping. All units require a 1/2 inch pipe connection at the gas valve.

**GAS CONNECTION**

The gas supply line can be routed through the hole located on the left side of the unit. Refer to Figure 7 to locate these access openings. Typical supply piping arrangements are shown in Figure 5.

Gas piping recommendations:

1. A drip leg and a ground joint union must be installed in the gas piping.
2. When required by local codes, a manual shut-off valve may have to be installed outside of the unit.
3. Use wrought iron or steel pipe for all gas lines. Pipe dope should be applied sparingly to male threads only.

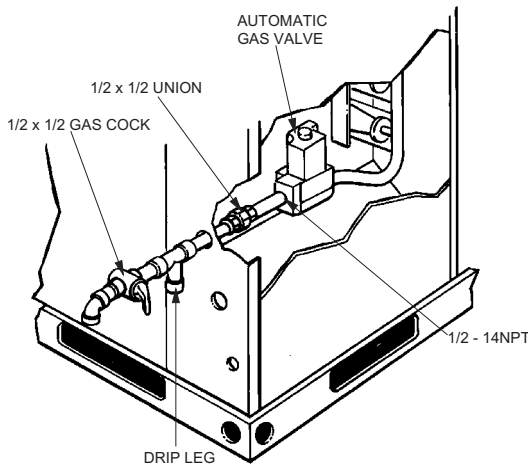

**FIGURE 5 - EXTERNAL SUPPLY CONNECTION  
EXTERNAL SHUT-OFF**

**TABLE 5: NATURAL GAS PIPE SIZING CHART<sup>1</sup>**

LENGTH IN FEET	NOMINAL INCHES IRON PIPE SIZE			
	1/2"	3/4"	1"	1-1/4"
10	132	278	520	1,050
20	92	190	350	730
30	73	152	285	590
40	63	130	245	500
50	56	115	215	440
60	50	105	195	400
70	46	96	180	370
80	43	90	170	350
90	40	84	160	320
100	38	79	150	305

<sup>1</sup>. Maximum capacity of pipe in cubic feet of gas per hour (based upon a pressure drop of 0.3 inch water column and 0.6 specific gravity gas).

**TABLE 6: PROPANE (LP) GAS PIPE SIZING  
CHART<sup>1</sup>**

LENGTH IN FEET	NOMINAL INCHES IRON PIPE SIZE			
	1/2"	3/4"	1"	1-1/4"
10	275	567	1,071	2,205
20	189	393	732	1,496
30	152	315	590	1,212
40	129	267	504	1,039
50	114	237	448	913
60	103	217	409	834
70	96	196	378	771
80	89	185	346	724
90	83	173	322	677
100	78	162	307	630

<sup>1</sup>. Maximum capacity of pipe in thousands of BTU per hour (based upon a pressure drop of 0.5 inch water column).



**CAUTION**

If flexible stainless steel tubing is allowed by the authority having jurisdiction, wrought iron or steel pipe must be installed at the gas valve and extend a minimum of two (2) inches outside of the unit casing.

**WARNING**

Natural gas may contain some propane. Propane being an excellent solvent, will quickly dissolve white lead or most standard commercial compounds. Therefore, a special pipe dope must be applied when wrought iron or steel pipe is used. Shellac base compounds such as gaskoloc or stastic, and compounds such as rectorseal # 5, Clyde's or John Crane may be used.

4. All piping should be cleaned of dirt and scale by hammering on the outside of the pipe and blowing out the loose dirt and scale. Before initial start-up, be sure that all of the gas lines external to the unit have been purged of air.
5. The gas supply should be a separate line and installed in accordance with all safety codes as prescribed under Limitations. After the gas connections have been completed, open the main shut-off valve admitting normal gas pressure to the mains. Check all joints for leaks with soap solution or other material suitable for the purpose. NEVER USE A FLAME.
6. The furnace and its individual manual shut-off valve must be disconnected from the gas supply piping system during any pressure testing of that system at test pressures in excess of 1/2 psig (3.48 kPa).

The furnace must be isolated from the gas supply piping system by closing its individual manual shut-off valve during any pressure testing of the gas supply piping system at test pressures equal to or less than 1/2 psig (3.48 kPa).

**FLUE VENT HOOD**

The flue vent hood with screen is not shipped attached. This hood must be installed to assure proper unit operation. The hood must be fastened to the outside of the side gas control/electrical compartment with the screws provided in the bag attached to the inside of the gas control/electrical compartment, see Figure 6.

**WARNING**

Flue hood surfaces may be hot.

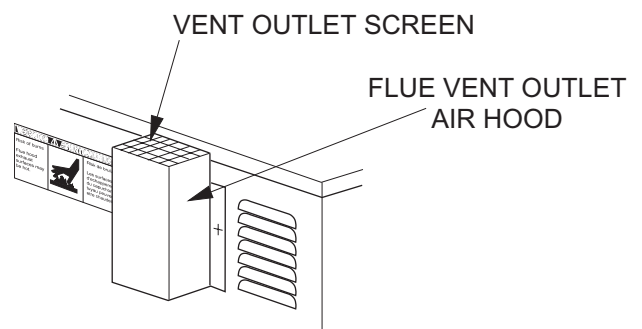

**FIGURE 6 - FLUE VENT OUTLET AIR HOOD**

**CAUTION**

The flue exhaust hood must be properly installed and within the recommended clearances. Further communications and action must be given to the home or building owner(s) to eliminate any unauthorized human contact around this area during the heating cycle. Flue hood surface and immediate area are designed to operate at high temperatures during the heating cycle.

TABLE 7: PHYSICAL DATA

MODEL		DNA						
		018	024	030	036	042	048	060
EVAPORATOR BLOWER	CENTRIFUGAL BLOWER (Dia. x W. in.)	10 x 8	10 x 8	10 x 8	11 x 10	11 x 10	12 x 11	12 x 11
	FAN MOTOR HP (3 Speed)	1/2	1/2	1/2	3/4	3/4	1	1
EVAPORATOR COIL	ROWS DEEP	2	2	2	2	3	3	3
	FINS PER INCH	14	13	13	15	13	13	13
	FACE AREA (Sq. Ft.)	2.25	3.5	3.5	3.5	3.5	4.5	4.5
CONDENSER FAN	PROPELLER DIA. (in.)	22	22	22	22	22	22	22
	FAN MOTOR HP	1/4	1/4	1/4	1/4	1/4	1/4	1/4
	NOM. CFM TOTAL	1,800	2,200	2,400	2,400	2,400	3,000	3,000
CONDENSER COIL	ROWS DEEP	1	1	1	1	1	1	1
	FINS PER INCH	13	13	16	20	20	20	20
	FACE AREA (Sq. Ft.)	8.3	8.3	11.7	11.7	11.7	14.8	14.8
CHARGE	REFRIGERANT 22 (lbs./oz.)	3 / 2	3 / 16	4 / 12	4 / 3	4 / 9	6 / 0	5 / 4
FILTER <sup>1</sup>	FACE AREA (Sq. Ft.) Size (Nominal)	2.6/20x20	2.6/20x20	2.6/20x20	2.6/20x20	2.6/20x20	3.3/20x12	3.3/20x12
FURNACE SECTION	NATURAL GAS BURNER ORIFICE NO. (Drill Size)	43	43	43	43	43	40	40
	PROPANE BURNER ORIFICE NO. (Drill Size)	55	55	55	55	55	53	53
	GAS CONNECTION SIZE	1/2 NPTI	1/2 NPTI	1/2 NPTI	1/2 NPTI	1/2 NPTI	1/2 NPTI	1/2 NPTI
COMPRESSOR TYPE	HERMETICALLY SEALED (R = RECIPROCATING, S = SCROLL)	R	R	R	R	R	S	S

1. See FILTERS on page 5.

TABLE 8: ELECTRICAL DATA

MODEL DNA	POWER SUPPLY	VOLTAGE LIMITATIONS <sup>1</sup>		COMPRESSOR		COND. FAN MOTOR, FLA	SUPPLY AIR BLOWER MOTOR FLA	MINIMUM CIRCUIT AMPACITY	MAX. FUSE SIZE, AMPS <sup>2</sup>	MAX. HACR BREAKER SIZE, AMPS	UNIT POWER FACTOR	TRANSFORMER SIZE (VA)
		MIN.	MAX.	RLA	LRA							
018	208/230-1-60	187	253	9.0	48.0	1.1	2.2	14.5	20	20	.96	40
024	208/230-1-60	187	253	11.5	60.0	1.1	2.2	17.7	25	25	.96	40
030	208/230-1-60	187	253	14.7	73.0	1.1	2.2	21.7	30	30	.96	40
036	208/230-1-60	187	253	17.3	94.0	1.1	3.5	26.2	35	35	.96	40
042	208/230-1-60	187	253	15.4	86.0	1.1	3.5	23.9	30	30	.96	40
048	208/230-1-60	187	253	24.4	140.0	1.3	7.0	38.8	50	50	.96	40
060	208/230-1-60	187	253	28.9	175.0	1.3	7.0	44.4	60	60	.96	40

1. Utilization range "A" in accordance with ARI Standard 110.

2. Dual element, time delay type.

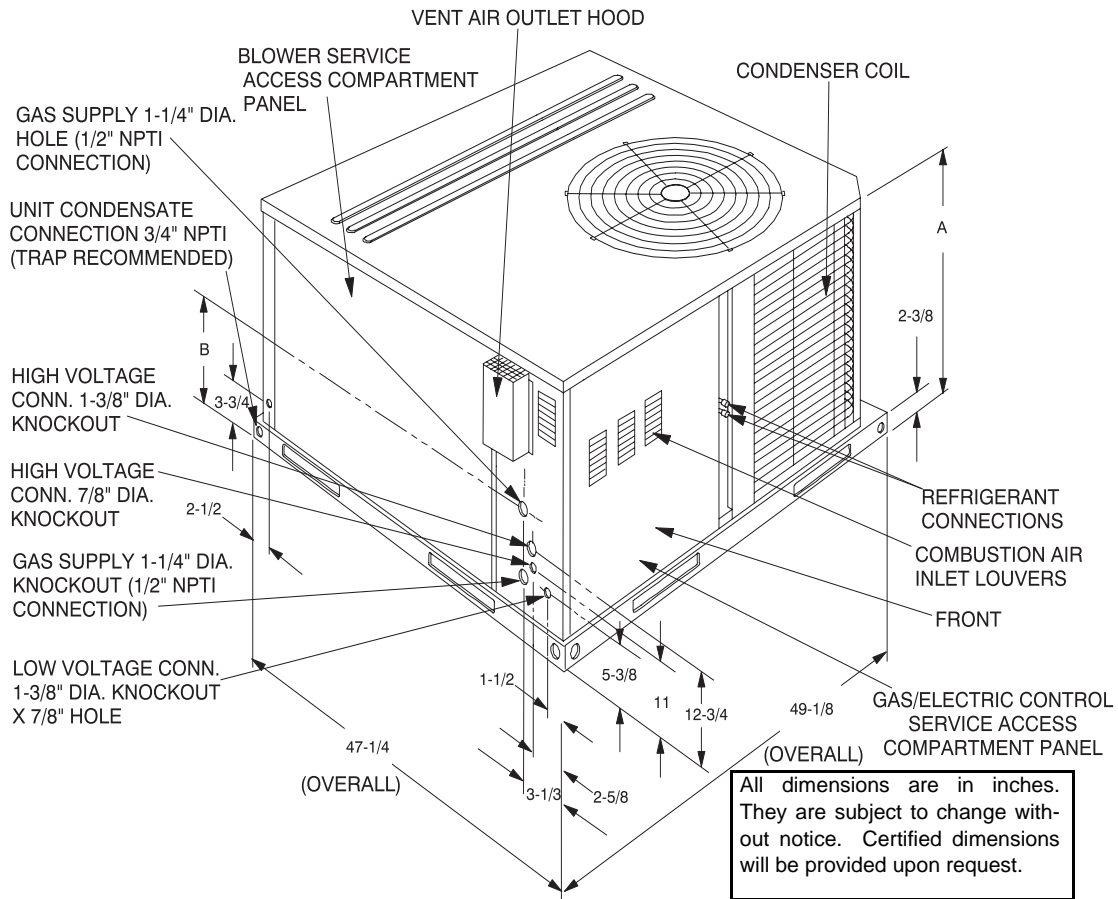

FIGURE 7 - UNIT DIMENSIONS - FRONT

TABLE 9: UNIT DIMENSIONS FRONT

UNIT SIZE	DIMENSION	
	"A"	"B"
018 thru 042	33-1/2	18-1/4
048 and 060	41-1/2	23-1/8

TABLE 10: UNIT MINIMUM CLEARANCES<sup>1 2</sup>

CLEARANCES	
FRONT	36"
BACK	0"
LEFT SIDE (Filter-Access)	24"
RIGHT SIDE	12"
BELOW UNIT <sup>3</sup>	0"
ABOVE UNIT <sup>4</sup>	36" (For Condenser Air Discharge)

1. A 1" clearance must be provided between any combustible material and the supply 7 air ductwork.
2. The products of combustion must not be allowed to accumulate within a confined space and recirculate.
3. Units may be installed on combustible floors made from wood or class A, B, or C roof covering material.
4. Units must be installed outdoors. Overhanging structures or shrubs should not obstruct condenser air discharge outlet.

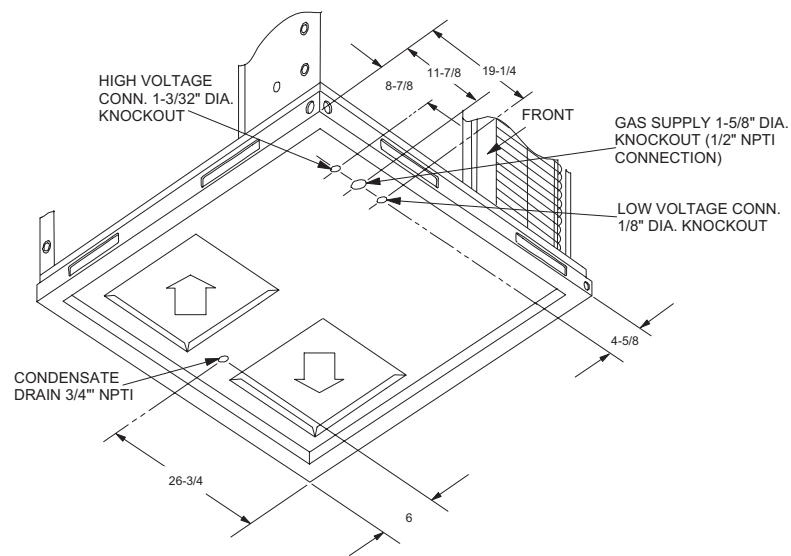

**FIGURE 8 - UNIT DIMENSIONS - FRONT & BOTTOM**

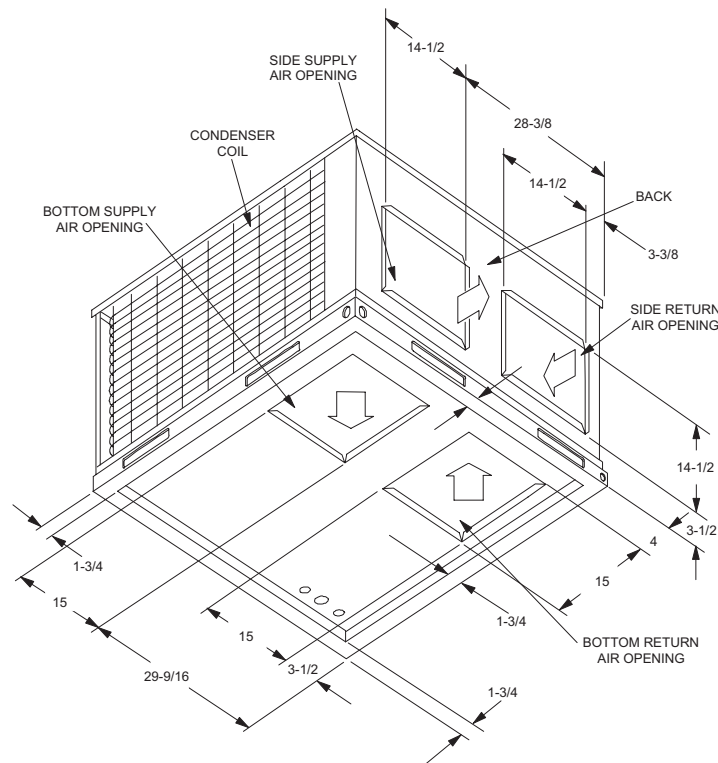

**FIGURE 9 - UNIT DIMENSIONS - BACK & BOTTOM**

## SEQUENCE OF OPERATION

The unit is controlled by a conventional heating/cooling thermostat common to this class of equipment.

### HEATING

The control board begins a call for heat when W1 is energized (connected to R). The control ignores W2 until pilot ignition has been established.

The control checks to see if the pressure switch is open. If the pressure switch is closed, the control board flashes "3" on the LED and waits indefinitely for it to open. When the pressure switch is sensed as open, the control begins pressure switch proving period. If the call for heat is lost, the control goes back to Standby.

### PRESSURE SWITCH PROVING

The control board energizes the induced draft motor (High speed for 2 stage model) and waits for the low pressure switch to close. When the low pressure switch closes, the control begins Pre-purge period. If the call for heat is lost, the control de-energizes the inducer without post-purge and returns to standby.

If the low pressure switch does not close within 10 seconds of inducer energizing, the control board flashes "2" on the LED. If the pressure switch does not close within 5 minutes of inducer energizing, the control shuts off the inducer for 30 seconds, then energizes the inducer for another 5 minute try to close the pressure switch. This cycle continues indefinitely until either the pressure switch is proved closed, or the call for heat ends.

### PRE-PURGE

The control board monitors the low pressure switch and ensures it remains closed during pre-purge. If the pressure switch opens, the control goes back to pressure switch proving mode. The control waits for a 15 second pre-purge period, then begins the ignition trial

### IGNITION TRIAL PERIOD

The control board energizes the pilot gas valve and spark outputs for an 85 second Ignition trial. The control de-energizes the spark when flame is sensed and enters a flame stabilization period.

If flame is not established within the ignition trial period, the control de-energizes the spark and gas valve and begins an inter-purge period before attempting another ignition trial.

If the call for heat is lost during an ignition trial period, the control immediately de-energizes spark and gas. The control runs the inducer motor through a post purge period before de-energizing.

If the pressure switch is lost during an ignition trial period, the control immediately de-energizes spark and gas. The control

begins pressure switch proving before an inter-purge and re-ignition attempt.

### PILOT FLAME STABILIZATION PERIOD

The control board de-energizes the spark output, and waits for a 2 second flame stabilization period before energizing the main gas valve.

If flame is lost during the flame stabilization period, the control board counts it as a flame loss and retries ignition or locks out flashing a "5" on the LED.

### HEAT BLOWER ON DELAY

The control board waits for 30 seconds and then energizes the indoor blower heat speed. Blower on delay time begins at the start of flame proving period in the trial for ignition.

If the thermostat demand for heat is removed, the control de-energizes the gas valve, energizes the blower on heat speed and initiates a post-purge and heat blower off delay.

### MAIN BURNER OPERATION

#### High heat warm-up

Two stage models run high heat for the first 60 seconds following Pilot Flame Stabilization period regardless of W2 demand. If W2 is not energized at the end of this 60 second period the control de-energizes the high gas output and steps the inducer to low speed. If W2 is energized the control remains on high heat.

There is no high heat warm-up on single stage models

#### Low heat

The control board keeps the pilot gas valve, main gas valve and induced draft motor energized while continuously monitoring the call for heat, low pressure switch, and flame status.

If the call for heat (W1) is lost, the control de-energizes the gas valve and begins post purge.

If low pressure switch opens, the control de-energizes the gas valve and begins pressure switch proving mode.

If flame is lost, the control de-energizes the gas valve within 2.0 second and counts the flame loss. If flame has been lost more than 16 times within the same call for heat, the control board locks out flashing "5" on the LED. If flame has been lost less than 16 times, the control attempts re-ignition after a 300 second inter-purge period.

#### High heat

If the W2 terminal was energized more than 1 second before W1 at the start of the call for heat, and remains continuously energized through the call for heat, the control considers it to be connected to a single stage thermostat and implements a 10 minute Auto staging feature. The 2nd stage thermostat call is ignored until 10 minutes into steady heat (9 minutes after high heat warm-up ended).

The control recognizes a call for 2nd stage heat when W2 is energized (connected to "R"). The control energizes the high gas output and induced draft motor on high speed.

If the call for 2nd stage heat goes away and the 1st stage call remains, the control de-energizes the high gas valve, drops inducer speed to low, and returns to low heat operation.

Response to loss of W1, low pressure switch, and flame are identical to low heat operation.

### POST PURGE

The control board runs the induced draft motor for a 30 second post-purge period, and then de-energizes the inducer. If a call for heat occurs during post-purge, the control finishes the post-purge, drops inducer out to re-prove open pressure switch before continuing with the heat cycle.

### HEAT BLOWER OFF DELAY

The control board de-energizes the indoor blower motor after a delay time as selected by movable shunt (60, 90, 120 or 180 seconds). Blower timing begins when the thermostat is satisfied or heat cycle was interrupted. The control returns to standby when the blower off delay is complete.

If the thermostat call for heat returns before the blower off delay is complete, the control begins an ignition sequence with pre-purge while the blower off delay continues.

### LOCKOUT

While in lockout, the control board keeps the pilot gas valve, main gas valve and induced draft motor de-energized.

Lockouts due to failed ignition or flame losses may be reset by removing the call for heat (W1) for more than 1 second, but less than 20 seconds, or by removing power from the control for over 0.25 seconds. The control will automatically reset lockout after 60 minutes.

Lockouts due to detected internal control faults will reset after 60 minutes or power interruption.

### HIGH TEMPERATURE LIMIT SWITCH

Any time the high temperature limit switch is open the control board will run the indoor blower motor on heat speed, the inducer (on high speed for 2 stage models), de-energize the gas valve, and flash "6" on the LED. When the high temperature switch closes, the control will restart the ignition sequence beginning with pre-purge.

### ROLLOUT SWITCH

If the rollout switch opens for more than 0.25 seconds, the control board will run the inducer (on high speed for 2 stage models) for a post-purge period, immediately de-energize the gas valve, and flash "7" on the LED. The blower output will be energized during an open rollout condition.

If the rollout switch closes, the control shall remain locked out until power removed or "W" is removed.

Rollout switch lockout shall not reset automatically.

### POWER INTERRUPTIONS

Power interruptions of any duration shall not cause lockout or any operation requiring manual intervention.

### FLAME PRESENT WITH GAS OFF

If flame is sensed for longer than 4.0 seconds during a period when the gas valve should be closed, the control will enter lockout flashing "8" on the LED. The control will turn on the inducer blower while the flame is present.

### GAS VALVE STUCK OPEN OR CLOSED

If either or both Pilot and Main Gas valve outputs are sensed to be off for more than 1 second when commanded to be on, the control board shuts off all outputs and enters a hard lockout flashing "9" on the LED.

If the Pilot valve or Main valve output is sensed to be energized for more than 1 second when commanded to be off, the control de-energizes the induced draft motor (if flame is not present) to attempt to open the pressure switch to de-energize the gas valve. If the pilot or main gas valve is still sensed as energized after the inducer has been off for 5 seconds, the control re-energizes the inducer to attempt to vent the unburned gas. In either case, the control enters a hard lockout flashing "9" on the LED. If the pilot or main valve becomes Un-Welded the inducer will de-energize, but the control will remain in a hard lockout and not respond to any thermostat demands.

The only way to recover from a hard lockout is to remove and then reapply 24VAC power to the control board.

### FLAME SENSE CIRCUIT FAILURE

If the control detects an internal hardware failure in the flame sense circuit, it shuts off all outputs and enters a hard lockout flashing "10" on the LED. The control will not respond to thermostat demands during a hard lockout.

The only way to recover from a hard lockout is to remove and then reapply 24VAC power to the control. If problem persist after removal and reapplication of 24VAC power, the board may need to be replaced.

### SAFETY CONTROLS

The control circuit includes the following safety controls:

1. **Limit Switch (LS)** - This control is located inside the heat exchanger compartment and is set to open at the temperature indicated in the Temperature Controls Table of the unit wiring diagram. It resets automatically. The limit switch operates when a high temperature condition caused by inadequate supply air flow occurs, thus shutting down the ignition control and closing the main gas valve and energizing the blower.

2. **Pressure Switch (PS)** - If the draft motor should fail, the pressure switch prevents the ignition controls and gas valves from being energized.
3. **Flame Sensor** - The flame sensor and controls are located per Proper Flame Adjustment, Figure 12. If an ignition control fails to detect a signal from the flame sensor indicating the pilot flame is properly ignited, then the main gas valve will not open.
4. **Rollout Switch (RS)** - This switch is located in the burner vestibule. In the event of a sustained main burner flame rollout, it shuts off the ignition control and closes the main gas valve.

**NOTE:** The manual reset Rollout Switch (RS) must be reset before allowing furnace operation.

5. **Auxiliary Limit Switch (ALS)** - This control is located inside the heat exchanger compartment and is set to open at 160°F. It is a manual reset switch. If ALS trips, then the primary limit (LS) has not functioned correctly. Replace the primary limit LS.

**TABLE 11: IGNITION CONTROL BOARD FLASH CODES**

Flash Code	Description
Heart Beat	Normal Operation
2 Flashes	Pressure switch open with inducer on
3 Flashes	Pressure switch closed with inducer off
4 Flashes	Not Used
5 Flashes	Lockout from too many flame losses
6 Flashes	High temperature switch open
7 Flashes	Rollout switch open
8 Flashes	Flame present with gas off
9 Flashes	Gas valve stuck OFF or ON
10 Flashes	Flame sense circuit failure

## COOLING

When the thermostat calls for COOL, the thermostat terminals G and Y are energized signaling the compressor and outdoor fan to run.

With a call for Y, the circulating fan is energized at cooling speed.

When the thermostat is satisfied, terminals G and Y are de-energized, de-energizing the compressor and outdoor fan.

After a cool fan off delay timing of 30 seconds the circulating fan is de-energized.

## CIRCULATING FAN

When the thermostat calls for FAN, the thermostat terminal G is energized signaling the circulating fan to run at the cool speed.

If a call for COOL occurs, the circulating fan continues to run at the cool speed.

If a call for HEAT occurs, the circulating fan switches to heat speed after a 30 second delay.

When the thermostat ends the call for FAN, the thermostat terminal G is de-energized, de-energizing the circulating fan.

## START-UP

### PRE-START CHECK LIST

Complete the following checks before starting the unit.

1. Check the type of gas being supplied. Be sure that it is the same as listed on the unit nameplate.
2. Make sure that the vent outlet air hoods has been properly installed.

### OPERATING INSTRUCTIONS

1. STOP! Read the information on the unit safety label.
2. Set the thermostat to the OFF position.
3. Turn off all electrical power to the unit.
4. DO NOT try to light the burners by hand. This appliance is equipped with an ignition device which automatically lights the burners.
5. Remove the access panel.
6. Turn the gas valve switch to the OFF position.
7. Wait five (5) minutes to clear out any gas. If you then smell gas, STOP! Follow B in the information on the unit safety label. If you don't smell gas, go to the next step.
8. Turn the gas valve switch to the ON position.
9. Replace the control access panel.
10. Turn on all electric power to the unit.
11. Set the thermostat to the desired setting.
12. If the unit will not operate, follow the instructions To Turn Off Gas To Appliance and call your service technician or gas supplier.

### TO TURN OFF GAS TO UNIT

1. Set the thermostat to the OFF position.

- Turn off all electric power to the appliance if service is to be performed.
- Remove the control access panel.
- Turn the gas valve switch to the OFF position. DO NOT FORCE.
- Replace the control access panel.

### POST-START CHECK LIST (GAS)

After the entire control circuit has been energized and the heating section is operating, make the following checks:

- Check for gas leaks in the unit piping as well as the supply piping.
- Check for correct manifold gas pressures. See Checking Gas Input.
- Check the supply gas pressure. It must be within the limits shown on rating nameplate. Supply pressure should be checked with all gas appliances in the building at full fire. At no time should the standby gas line pressure exceed 10.5", nor the operating pressure drop below 4.5" for natural gas units. If gas pressure is outside these limits, contact the local gas utility for corrective action.

### MANIFOLD GAS PRESSURE ADJUSTMENT

Small adjustments to the gas flow may be made by turning the pressure regulator adjusting screw on the automatic gas valve. Refer to Figure 10.

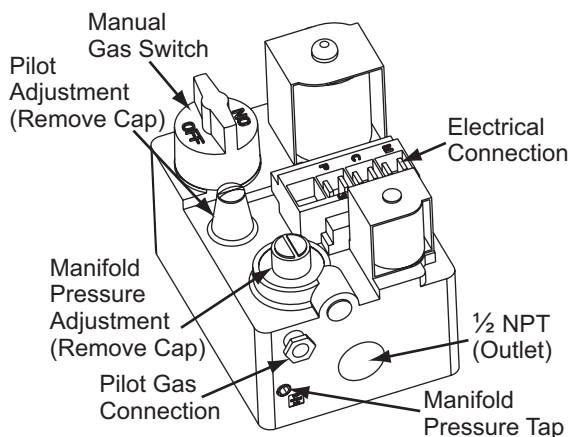

**FIGURE 10 - GAS VALVE - FRONT**

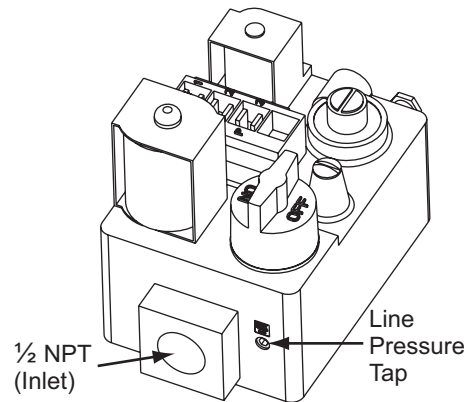

**FIGURE 11 - GAS VALVE - REAR**

Adjust as follows:

- Remove the cap from the valve body. See Figure 10 for location.
- To decrease the gas pressure, turn the adjusting screw counterclockwise.
- To increase the gas pressure, turn the adjusting screw clockwise.

**NOTE:** The correct manifold pressure for natural gas furnaces is 3.5 IWG. The correct manifold pressure for propane (LP) is 10.0 IWG.

### BURNER INSTRUCTIONS

To check or change the burners, CLOSE THE MAIN MANUAL SHUT-OFF VALVE AND SHUT OFF ALL POWER TO THE UNIT.

- Remove the two (2) #8 screws holding each burner in place.
- Remove the burner assembly from the manifold assembly by moving the burner assembly forward, turn at an angle and pull back.
- Burners are now accessible for service.

### PILOT INSTRUCTIONS

To check, adjust or remove the pilot assembly, CLOSE THE MAIN MANUAL SHUT-OFF VALVE AND SHUT OFF ALL POWER TO THE UNIT.

The pilot flame should envelope 3/8 inch of the end of the flame sensor and not contain any yellow color, see Figure 12.



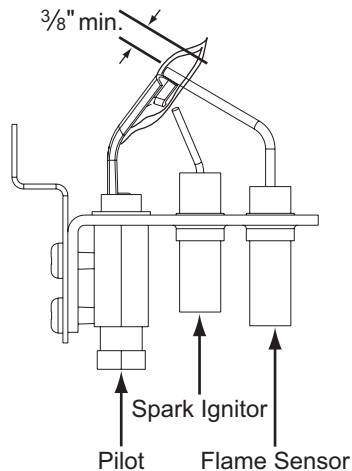

**FIGURE 12 - PROPER FLAME ADJUSTMENT**

To adjust the pilot flame:

1. Remove the pilot adjustment cover screw.
2. Adjust the pilot adjustment screw to achieve the proper pilot flame.
3. Replace the pilot adjustment cover screw after the pilot flame is set.

To remove the pilot assembly:

1. Disconnect the wiring from the control board to the pilot assembly.
2. Remove the two (2) #8 screws holding the pilot assembly in place.
3. Remove the pilot assembly.

### ADJUSTMENT OF TEMPERATURE RISE

$$\text{Degrees F Temp Rise} = \frac{\text{BTUH Output}}{1.08 \times \text{CFM}}$$

OR

$$\text{CFM} = \frac{\text{BTUH Output}}{1.08 \times \text{Degrees F Temp Rise}}$$

The temperature rise (or temperature difference between the return air and the heated air from the furnace) must lie within the range shown on the rating plate and the data in Tables 3 and 4.

After the temperature rise has been determined, the CFM can be calculated as follows:

After about 20 minutes of operation, determine the furnace temperature rise. Take readings of both the return air and the heated air in the ducts about six feet from the furnace where they will not be affected by radiant heat. Increase the blower CFM to decrease the temperature rise; decrease the blower CFM to increase the rise.

### DIRECT DRIVE BLOWER

All units have direct drive multi-speed blower motors. Refer to the unit wiring diagram and connect the blower motor for the desired motor speed.

### CHECKING GAS INPUT

#### NATURAL GAS

1. Turn off all other gas appliances connected to the gas meter.
2. With the furnace turned on, measure the time needed for one revolution of the hand on the smallest dial on the meter. A typical gas meter usually has a 1/2 or a 1 cubic foot test dial.
3. Using the number of seconds for each revolution and the size of the test dial increment, find the cubic feet of gas consumed per hour from Table 12.

If the actual input is not within 5% of the furnace rating with allowance being made for the permissible range of the regulator setting, replace the orifice spuds with spuds of the proper size.

**NOTE:** To find the BTU input, multiply the number of cubic feet of gas consumed per hour by the BTU content of the gas in your particular locality. (Contact your gas company for this information since it varies widely from city to city.)

**TABLE 12: GASE RATE - CUBIC FEET PER HOUR<sup>1</sup>**

SECONDS FOR ONE REV.	SIZE OF TEST DIAL	
	1/2 CU. FT.	1 CU. FT.
10	180	360
12	150	300
14	129	257
16	113	225
18	100	200
20	90	180
22	82	164
24	75	150
26	69	138
28	64	129
30	60	120
32	56	113
34	53	106
36	50	100
38	47	95
40	45	90
42	43	86
44	41	82
46	39	78
48	37	75
50	36	72
52	35	69
54	34	67
56	32	64
58	31	62
60	30	60

- <sup>1</sup> *EXAMPLE:* By actual measurement, it takes 38 seconds for the hand on the 1-cubic foot dial to make a revolution with just a 100,000 BTUH furnace running. Using this information, locate 38 seconds in the first column of Table 12. Read across to the column headed "1 Cubic Foot," where you will see that 95 cubic feet of gas per hour are consumed by the furnace at that rate. Multiply 95 x 1050 (the BTU rating of the gas obtained from the local gas company). The result is 99,750 BTUH, which is close to the 100,000 BTUH rating of the furnace.

**CHECKING SUPPLY AIR CFM**

To check the supply air CFM after the initial balancing has been completed:

1. Remove the two ¼ inch dot plugs in the duct panel.
2. Insert at least 8 inches of ¼ inch tubing into each of these holes for sufficient penetration into the airflow on both sides of the indoor coil.
3. Using an inclined manometer, determine the pressure drop across the dry evaporator coil. Since the moisture on an evaporator coil may vary greatly, measuring the pressure drop across a wet coil under field conditions would be inaccurate. To ensure a dry coil, the compressors should be deactivated while the test is being run.
4. Knowing the pressure drop across a dry coil, the actual CFM through the unit can be determined from the curve in Coil Delta P vs. Supply Air CFM figure.

<b>▲WARNING</b>
-----------------

Failure to properly adjust the total system air quantity can result in extensive system damage.
---

After readings have been obtained, remove the tubes and reinstall the two ¼ inch plugs removed in Step 1.

De-energize the compressors before taking any test measurements to ensure a dry indoor coil.

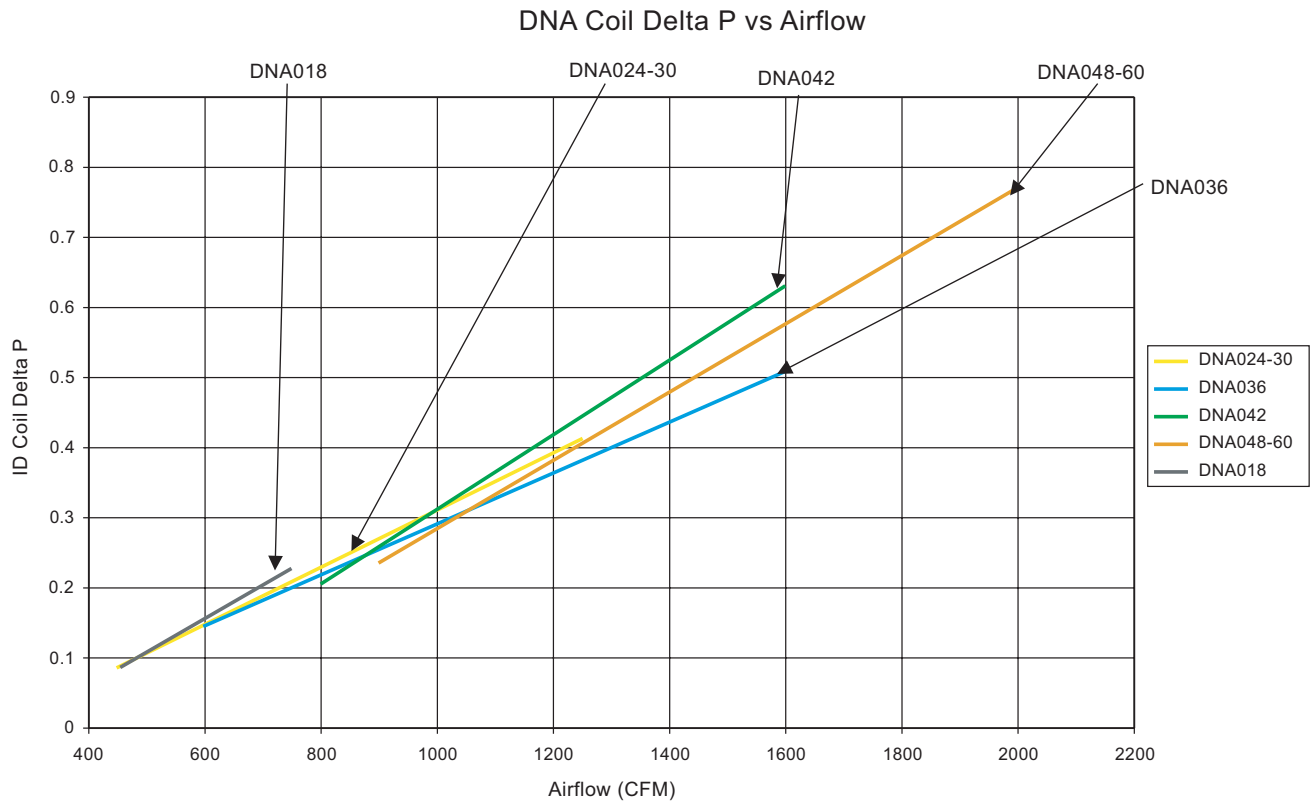

FIGURE 13 - DNA COIL DELTA P VS. AIRFLOW

TABLE 13: SUPERHEAT CHARGING TABLE FOR DNA018

OUTDOOR TEMP. °F	SUPERHEAT AT COMPRESSOR SUCTION (F), AIRFLOW = 400 CFM										
	INDOOR WB TEMP. (°F)										
	55	57	59	61	63	65	67	69	71	73	75
65	17.1	19.5	21.9	24.4	26.8	29.3	31.7	32.7	33.7	34.6	35.6
70	13.6	16.2	18.8	21.5	24.1	26.8	29.4	30.6	31.8	33.1	34.3
75	10.1	12.9	15.7	18.6	21.4	24.3	27.1	28.6	30.0	31.5	32.9
80	6.6	9.6	12.7	15.7	18.7	21.8	24.8	26.5	28.2	29.9	31.6
85	-	6.3	9.6	12.8	16.0	19.3	22.5	24.4	26.4	28.3	30.2
90	-	-	6.8	9.9	13.0	16.1	19.3	21.6	24.0	26.4	28.8
95	-	-	-	7.1	10.0	13.0	16.0	18.8	21.7	24.5	27.4
100	-	-	-	-	7.1	9.6	12.0	15.4	18.8	22.3	25.7
105	-	-	-	-	-	6.1	8.0	12.0	16.0	20.0	24.0
110	-	-	-	-	-	-	-	8.6	13.1	17.7	22.2
115	-	-	-	-	-	-	-	5.1	10.3	15.4	20.5

TABLE 14: SUPERHEAT CHARGING TABLE FOR DNA024

OUTDOOR TEMP. °F	SUPERHEAT AT COMPRESSOR SUCTION (F), AIRFLOW = 400 CFM										
	INDOOR WB TEMP. (°F)										
	55	57	59	61	63	65	67	69	71	73	75
65	13.9	16.5	19.0	21.5	24.1	26.6	29.2	29.7	30.3	30.9	31.5
70	9.5	12.5	15.5	18.5	21.5	24.5	27.5	28.2	28.8	29.4	30.1
75	5.2	8.6	12.1	15.5	19.0	22.4	25.9	26.6	27.3	28.0	28.7
80	-	-	8.7	12.5	16.4	20.3	24.2	25.0	25.8	26.5	27.3
85	-	-	5.2	9.6	13.9	18.3	22.6	23.4	24.2	25.1	25.9
90	-	-	-	7.8	11.9	16.1	20.3	21.5	22.7	23.8	25.0
95	-	-	-	6.0	10.0	14.0	18.0	19.5	21.1	22.6	24.2
100	-	-	-	-	8.4	12.1	15.9	17.7	19.5	21.3	23.1
105	-	-	-	-	6.9	10.3	13.8	15.8	17.9	20.0	22.0
110	-	-	-	-	5.3	8.5	11.7	14.0	16.3	18.7	21.0
115	-	-	-	-	-	6.7	9.6	12.2	14.8	17.3	19.9

TABLE 15: SUPERHEAT CHARGING TABLE FOR DNA030

OUTDOOR TEMP. °F	SUPERHEAT AT COMPRESSOR SUCTION (F), AIRFLOW = 400 CFM										
	INDOOR WB TEMP. (°F)										
	55	57	59	61	63	65	67	69	71	73	75
65	13.7	16.9	20.1	23.3	26.6	29.8	33.0	33.5	34.0	34.5	35.0
70	10.8	14.2	17.7	21.1	24.5	28.0	31.4	32.1	32.8	33.5	34.2
75	7.8	11.5	15.2	18.8	22.5	26.2	29.8	30.7	31.6	32.6	33.5
80	-	8.8	12.7	16.6	20.5	24.4	28.2	29.4	30.5	31.6	32.7
85	-	6.1	10.2	14.3	18.4	22.6	26.7	28.0	29.3	30.6	32.0
90	-	-	7.3	11.5	15.7	19.9	24.1	25.9	27.7	29.5	31.3
95	-	-	-	8.6	13.0	17.3	21.6	23.8	26.1	28.3	30.6
100	-	-	-	6.9	10.7	14.5	18.3	21.2	24.0	26.9	29.7
105	-	-	-	5.1	8.4	11.8	15.1	18.5	22.0	25.4	28.9
110	-	-	-	-	6.2	9.0	11.8	15.9	19.9	24.0	28.0
115	-	-	-	-	-	6.2	8.5	13.2	17.9	22.5	27.2

TABLE 16: SUPERHEAT CHARGING TABLE FOR DNA036

OUTDOOR TEMP. °F	SUPERHEAT AT COMPRESSOR SUCTION (F), AIRFLOW = 400 CFM										
	INDOOR WB TEMP. (°F)										
	55	57	59	61	63	65	67	69	71	73	75
65	27.1	28.4	29.7	31.1	32.4	33.7	35.0	35.9	36.8	37.6	38.5
70	23.3	24.8	26.2	27.7	29.2	30.6	32.1	33.5	34.9	36.4	37.8
75	19.5	21.1	22.7	24.4	26.0	27.6	29.2	31.2	33.1	35.1	37.1
80	15.7	17.5	19.2	21.0	22.8	24.5	26.3	28.8	31.3	33.8	36.3
85	11.9	13.8	15.7	17.6	19.6	21.5	23.4	26.5	29.5	32.6	35.6
90	8.6	10.6	12.6	14.6	16.6	18.6	20.6	24.1	27.6	31.1	34.6
95	5.3	7.4	9.5	11.5	13.6	15.7	17.8	21.7	25.7	29.7	33.7
100	-	5.6	7.6	9.6	11.6	13.6	15.6	20.1	24.5	28.9	33.4
105	-	-	5.7	7.6	9.6	11.5	13.5	18.4	23.3	28.2	33.1
110	-	-	-	5.6	7.5	9.4	11.3	16.7	22.1	27.4	32.8
115	-	-	-	-	5.5	7.4	9.2	15.0	20.9	26.7	32.5

**TABLE 17: SUPERHEAT CHARGING TABLE FOR DNA042**

OUTDOOR TEMP. °F	SUPERHEAT AT COMPRESSOR SUCTION (F), AIRFLOW = 400 CFM										
	INDOOR WB TEMP. (°F)										
	55	57	59	61	63	65	67	69	71	73	75
65	18.0	19.7	21.4	23.0	24.7	26.3	28.0	29.1	30.2	31.3	32.4
70	13.4	15.3	17.3	19.3	21.2	23.2	25.2	26.6	28.1	29.6	31.1
75	8.7	10.9	13.2	15.5	17.8	20.0	22.3	24.2	26.1	28.0	29.9
80	-	6.6	9.1	11.7	14.3	16.9	19.5	21.7	24.0	26.3	28.6
85	-	-	5.1	7.9	10.8	13.7	16.6	19.3	21.9	24.6	27.3
90	-	-	-	6.7	9.3	11.9	14.6	17.4	20.2	23.1	25.9
95	-	-	-	5.5	7.8	10.2	12.5	15.5	18.5	21.5	24.5
100	-	-	-	-	6.3	8.0	9.8	12.9	16.1	19.2	22.4
105	-	-	-	-	-	5.9	7.1	10.3	13.7	16.9	20.3
110	-	-	-	-	-	-	-	7.8	11.2	14.7	18.1
115	-	-	-	-	-	-	-	5.2	8.8	12.4	16.0

**TABLE 18: SUPERHEAT CHARGING TABLE FOR DNA048**

OUTDOOR TEMP. °F	SUPERHEAT AT COMPRESSOR SUCTION (F), AIRFLOW = 400 CFM										
	INDOOR WB TEMP. (°F)										
	55	57	59	61	63	65	67	69	71	73	75
65	20.9	21.8	22.7	23.6	24.4	25.3	26.2	27.4	28.6	29.8	31.0
70	17.6	18.7	19.7	20.7	21.7	22.7	23.7	25.2	26.6	28.1	29.6
75	14.4	15.5	16.6	17.8	18.9	20.0	21.2	22.9	24.7	26.4	28.2
80	11.1	12.4	13.6	14.9	16.1	17.4	18.6	20.7	22.7	24.8	26.8
85	7.8	9.2	10.6	12.0	13.3	14.7	16.1	18.4	20.8	23.1	25.4
90	5.8	7.0	8.2	9.3	10.5	11.7	12.9	15.7	18.6	21.5	24.4
95	-	-	5.8	6.7	7.7	8.6	9.6	13.0	16.5	19.9	23.3
100	-	-	5.4	6.0	6.7	7.4	8.0	11.6	15.2	18.7	22.3
105	-	-	-	5.3	5.7	6.1	6.5	10.2	13.9	17.6	21.3
110	-	-	-	-	-	-	-	8.7	12.6	16.4	20.3
115	-	-	-	-	-	-	-	7.3	11.3	15.3	19.3

**TABLE 19: SUPERHEAT CHARGING TABLE FOR DNA060**

OUTDOOR TEMP. °F	SUPERHEAT AT COMPRESSOR SUCTION (F), AIRFLOW = 400 CFM										
	INDOOR WB TEMP. (°F)										
	55	57	59	61	63	65	67	69	71	73	75
65	7.0	9.2	11.4	13.6	15.9	18.1	20.3	21.8	23.2	24.7	26.1
70	6.1	8.4	10.7	13.0	15.2	17.5	19.8	21.2	22.7	24.1	25.6
75	5.3	7.6	9.9	12.3	14.6	16.9	19.3	20.7	22.2	23.6	25.0
80	-	6.8	9.2	11.6	14.0	16.3	18.7	20.2	21.6	23.1	24.5
85	-	6.0	8.4	10.9	13.3	15.8	18.2	19.6	21.1	22.5	23.9
90	-	-	6.5	8.7	10.8	12.9	15.1	17.1	19.1	21.1	23.1
95	-	-	-	6.5	8.3	10.1	11.9	14.5	17.1	19.7	22.3
100	-	-	-	5.9	7.3	8.6	10.0	12.9	15.8	18.7	21.6
105	-	-	-	5.3	6.2	7.1	8.0	11.3	14.5	17.7	20.9
110	-	-	-	-	5.2	5.6	6.1	9.6	13.2	16.7	20.2
115	-	-	-	-	-	-	-	8.0	11.8	15.7	19.6

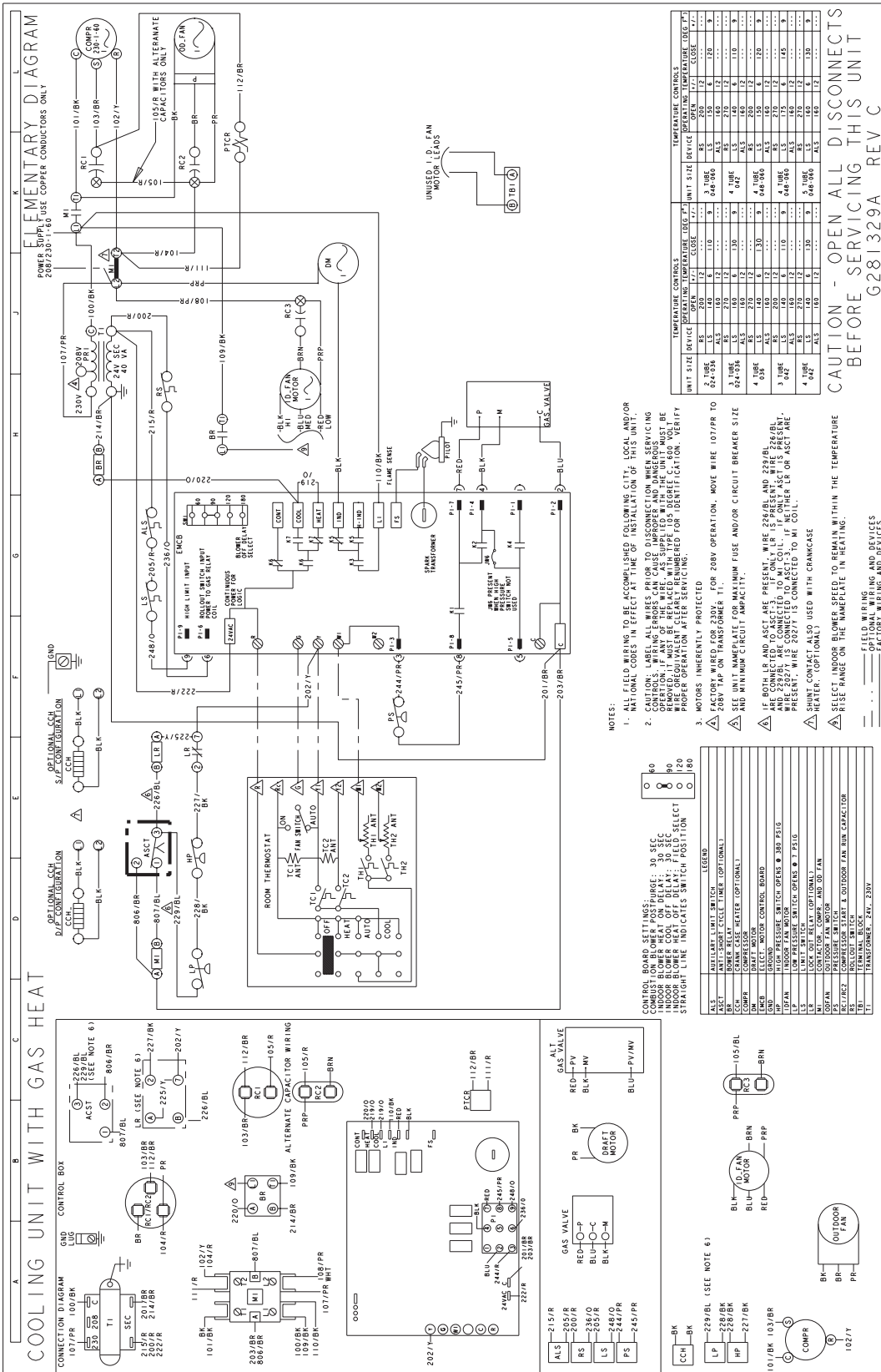

FIGURE 14: TYPICAL WIRING DIAGRAM DNA 018 THRU 060 (208/230-1-60 POWER SUPPLY)

## TYPICAL WIRING DIAGRAM NOTES (SEE FIGURE 14)

1. All field wiring to be accomplished following city, local and/or national codes in effect at time of installation of this unit.
2. Caution: Label all wires prior to disconnection when servicing controls. Wiring errors can cause improper and dangerous operation. If any of the wire as supplied with this unit must be removed it must be replaced with type 105°C, 600V wire or equivalent clearly renumbered for identification. Verify proper operation after servicing.
3. Motors inherently protected.
4. Factory wired for 230V. For 208V operation, move wire 107/PR to 208V. Tap on transformer T1
5. See unit nameplate for maximum fuse size and/or circuit breaker size and minimum circuit ampacity.
6. If both LR and ASCT are present, wire 801/BL and 805/BL are connected to ASCT-3. If only LR is present wire 801/BL and 805/BL are connected to M1 coil. If only ASCT is present wire 202/Y is connected to ASCT-3. If neither LR or ASCT are present, wire 202/Y is connected to M1 coil as shown.
7. Shunt contact also used with crankcase heater. (optional)
8. Select indoor blower speed to remain within the temperature rise range on the nameplate in heating.



LEGEND	
ALS	AUXILIARY LIMIT SWITCH
ASCT	ANTI-SHORT CYCLE TIMER (OPTIONAL)
BR	BLOWER RELAY
CB	CIRCUIT BREAKER
CCH	CRANK CASE HEATER (OPTIONAL)
COMPR	COMPRESSOR
DM	DRAFT MOTOR
FCB	FAN CONTROL BOARD
GND	GROUND
FS	FREEZE STAT SWITCH (OPTIONAL)
HP	HIGH PRESSURE SWITCH OPENS @ 380 PSIG
IDFAN	INDOOR FAN MOTOR
LP	LOW PRESSURE SWITCH OPENS @ 7 PSIG
LS	LIMIT SWITCH
LR	LOCK OUT RELAY (OPTIONAL)
M1	CONTACTOR, COMPR. AND OD FAN
ODFAN	OUTDOOR FAN MOTOR
PS	PRESSURE SWITCH
RC1 / RC2	COMPRESSOR START & OUTDOOR FAN RUN CAPACITOR
RS	ROLLOUT SWITCH
TB4	TERMINAL BLOCK
T1	TRANSFORMER, 24V, 230V

**FIGURE 15 - TYPICAL WIRING DIAGRAM LEGEND**

Subject to change without notice. Printed in U.S.A.  
Copyright © 2008 by Johnson Controls, Inc. All rights reserved.

340968-XIM-A-0108  
Supersedes: 286483-XIM-B-0807

---

**Johnson Controls Unitary Products**  
**5005 York Drive**  
**Norman, OK 73069**

Download from [Www.Somanuals.com](http://Www.Somanuals.com). All Manuals Search And Download.



## Free Manuals Download Website

<http://myh66.com>

<http://usermanuals.us>

<http://www.somanuals.com>

<http://www.4manuals.cc>

<http://www.manual-lib.com>

<http://www.404manual.com>

<http://www.luxmanual.com>

<http://aubethermostatmanual.com>

Golf course search by state

<http://golfingnear.com>

Email search by domain

<http://emailbydomain.com>

Auto manuals search

<http://auto.somanuals.com>

TV manuals search

<http://tv.somanuals.com>