

New Imaging Cameras

KY-F560/KY-F550

Sales Manual (Ver1.1)



JVC

JVC Imaging Camera Concept

JVC's every Imaging cameras meet analog to digital transition in each application.

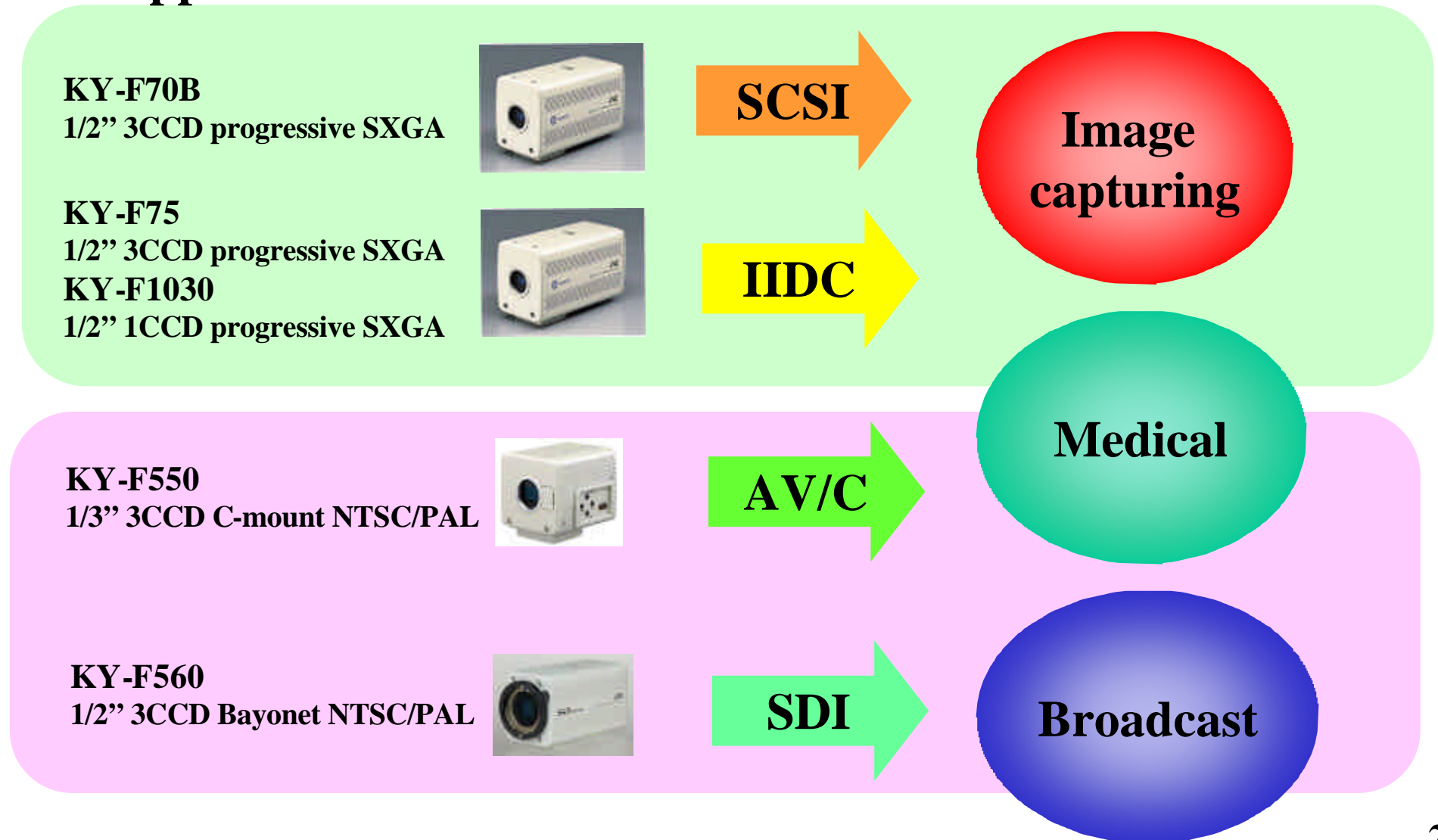

1/2" 3CCD Video Camera KY-F560U/E

Features & Advantages:

- ✎ High Quality, and compact size with **12bit A/D and 24bit DSP** for rich color reproduction
- ✎ High Sensitivity, **F13 at 2000lx** for low light application
- ✎ **Horizontal resolution 850lines**, S/N 64(NTSC)/62(PAL)dB
- ✎ Cost Effective Studio System available with **optional Studio adapter (Component/SDI)**
- ✎ Remote System available with optional PTZ Kit
- ✎ Expandability with Optional Boards (SDI)
- ✎ Squeezed 16:9 mode(Electronically processed)



Difference between KY-F560 and KY-F32

Comparison with KY-F32

Model	KY-F560	KY-F32
Dimensions(WxHxD)	70x80x164mm	70x80x164mm
Weight	800g	850g
Image size	1/2" 3CCD	1/2" 3CCD
Color separation	F1.4 RGB	F1.4 RGB
Lens mount	1/2" bayonet	1/2" bayonet
Sensitivity	F13/ 2000lx	F9.5/ 2000lx
Minimum illumination	F1.4 /0.5lx	F1.4/ 6lx
Horizontal resolution	850 lines	750 lines
S/N	64dB(NTSC)/62dB(PAL)	60dB(NTSC)/58dB(PAL)
Camera DSP	12bit ADC/24 bit DSP	Analog
ALC	Yes	Yes
EEI	Yes	Yes
White balance	Yes	Yes
Dynamic shading	Manual(vertical only)	Manual(vertical only)
Lens control	Iris only	Iris/Focus/Zoom
Random trigger	No	No
Genlock input	Yes	Yes
Composite output	Yes	Yes
Y/C output	Possible in conjunction with	Yes
RGB output	KA-F5602/F5603 and RM-	Yes
Component output	P210(selectable)	Yes
Extension slot	Yes	No
16:9 mode	Yes	No

Rear panel

KY-F560

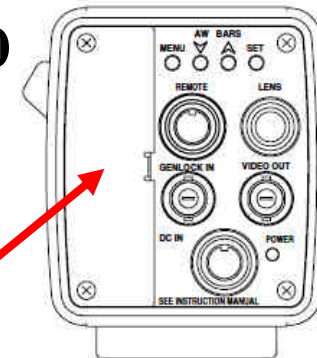

New

Extension slot for SDI output card (KA-F5601) or Studio adapter (KA-F5602/F5603)

KY-F32

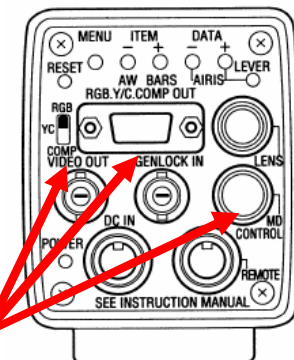

Delete

D-Sub connector(RGB, Y/C output)
Output signal select switch
MD lens control connector

Notice when swapping from KY-F32 to KY-F560

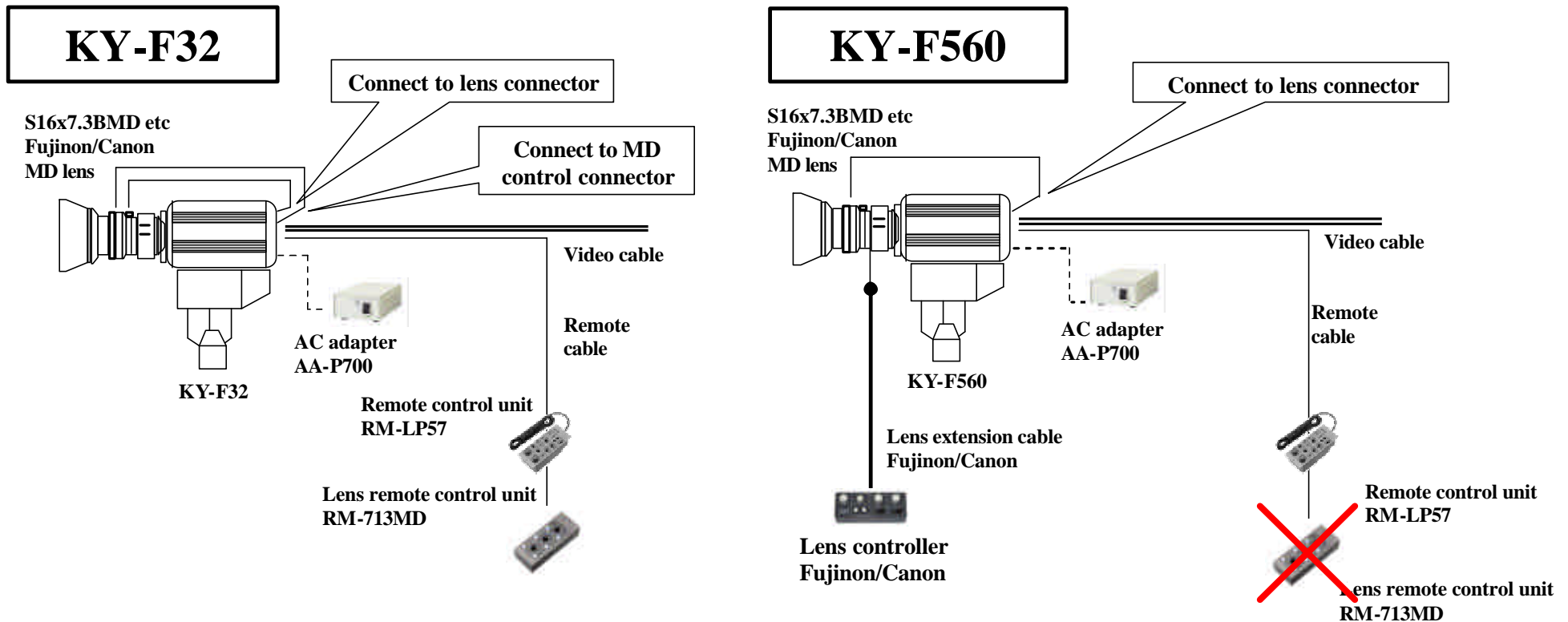

1. When the only camera part of KY-F560 is swapped from KY-F32.

2. When Fujinon CPT-70F-02A PTZ system is not used.

In this case, another lens controller and extension cable is required instead of RM-713MD

Fujinon: RM-D10/D20/D30 and exclusive extension cable

Canon: TCR-101F/201F/301F and exclusive extension cable

KY-F560 Menu Setup Contents

AE Level	-5 to +5	Setup(NTSC only)	0.0IRE/7.5IRE
AE Detect	Peak / Normal / AVG	Detail	OFF/MANUAL H/V balance:-5 to +5 Level:-10 to +10 Frequency:Low/Mid/High
AE Area	Full / Square / Spot / Normal(Top Cut) / Circle	Color Matrix	-3 to +3/STD/WARM/ /EXT1/EXT2/EXT3/OFF R Gain/R Rotation/G Gain/ G Rotation/B Gain/B Rotation
Shutter		Gamma	-5 to +5? OFF,CINEMA
Step	Normal, 1/100, 1/250, 1/500, 1/1000, 1/2000, 1/4000, 1/10000	Knee	80% to 100%, Auto
ELC	Yes(EEI)	White Clip	100%/108%
V.SCAN	1/60.1(50.1) to 1/10.1688k	Flare	R/MASTER/B -10~ +10
V.Resolution	Normal(Field) / VMAX(Frame)	Black	Stretch/Compress/OFF
Gain	AGC, LIMIT(+9, +12, +15, +18dB) , LOLUX(30dB)	Aspect Ratio	4:3/16:9(Squeeze)
Master Black	-10 to +10	Negative	Negative/Positive
White Balance	FAW/PRESET(3200K)/ R Gain, B Gain: 0 to 255, AUTO1/AUTO2	Pixel Compensation	Execute/Cancel
Genlock		Shading	R/G/B -128 to +127
H Phase	-128 to +127	File Manage	A,B,C
SC Coarse	0, 90, 180, 270 degree		
SC Fine	-128 to +127		

KY-F560 Menu Setup by Remote Controller

Function	Local	By RM-LP55	By RM-LP57
MODE	Yes	Yes(CAM/BARS/NEGA)	Yes(CAM/BARS)
NEGA	Yes	Yes	No
CONTOUR	Yes	Yes(ON(LEVEL)/OFF)	Yes(ON(LEVEL)/OFF)
GAMMA	Yes	No	No
MASTER BLACK	Yes	Yes(LEVEL)	Yes
IRIS	Yes	Yes(AUTO(LEVEL)/MANU)	Yes(AUTO(LEVEL)/MANU)
IRIS DETECT	Yes	Yes(NORMAL/PEAK/AVG)	No
WHITE BALANCE	Yes	Yes(AUTO1/AUTO2/FAW/ MANUAL/PRESET)	Yes(AUTO1/AUTO2/FAW)
WHITE PAINT	Yes	Yes(AUTO1/AUTO2)	Yes(AUTO1/AUTO2)
GAIN	Yes	Yes(-3/ 0/ 6/ 9/ 12/ 18dB/ ALC/ALC+EEI/ LOLUX)	Yes(0/ 6/ 9/ 12/ 18dB/ ALC/ALC+EEI)
SHUTTER	Yes	Yes(NORMAL/ 1/100(120)/ 1/250 / 1/500/ 1/1000/ 1/2000/ V.SCAN/ EEI)	Yes(NORMAL/ 1/100(120)/ 1/250 / 1/500/ 1/1000/ 1/2000/ EE)
FILE	Yes	Yes	No
H.PHASE	Yes	Yes(LEVEL)	Yes
SC COARSE	Yes	Yes(0° /90° /180° /270°)	Yes(0° /90° /180° /270°)
SC FINE	Yes	Yes	Yes
ZOOM	No	No	No
FOCUS	No	No	No
HI-RESO(Note 1)	Yes	Yes	No
WHITE SHADING	Yes	No	No

Note1:Equivalent to V.RESOLUTION NORMAL:HI-RESO OFF, V.MAX:HI-RESO ON

KY-F560 16:9 Squeeze mode

16:9 aspect ratio is available for KY-F560 selected by menu.(Squeezed 16:9)

Letter box system implemented into GY-DV5000 is simply masking the upper and lower part of 4:3 picture by black signal.

The DSP implemented into KY-F560 allows to convert 4:3 picture to 16:9 ratio electronically.

But, the vertical resolution of squeezed 16:9 picture deteriorates compared to the original 4:3 picture.

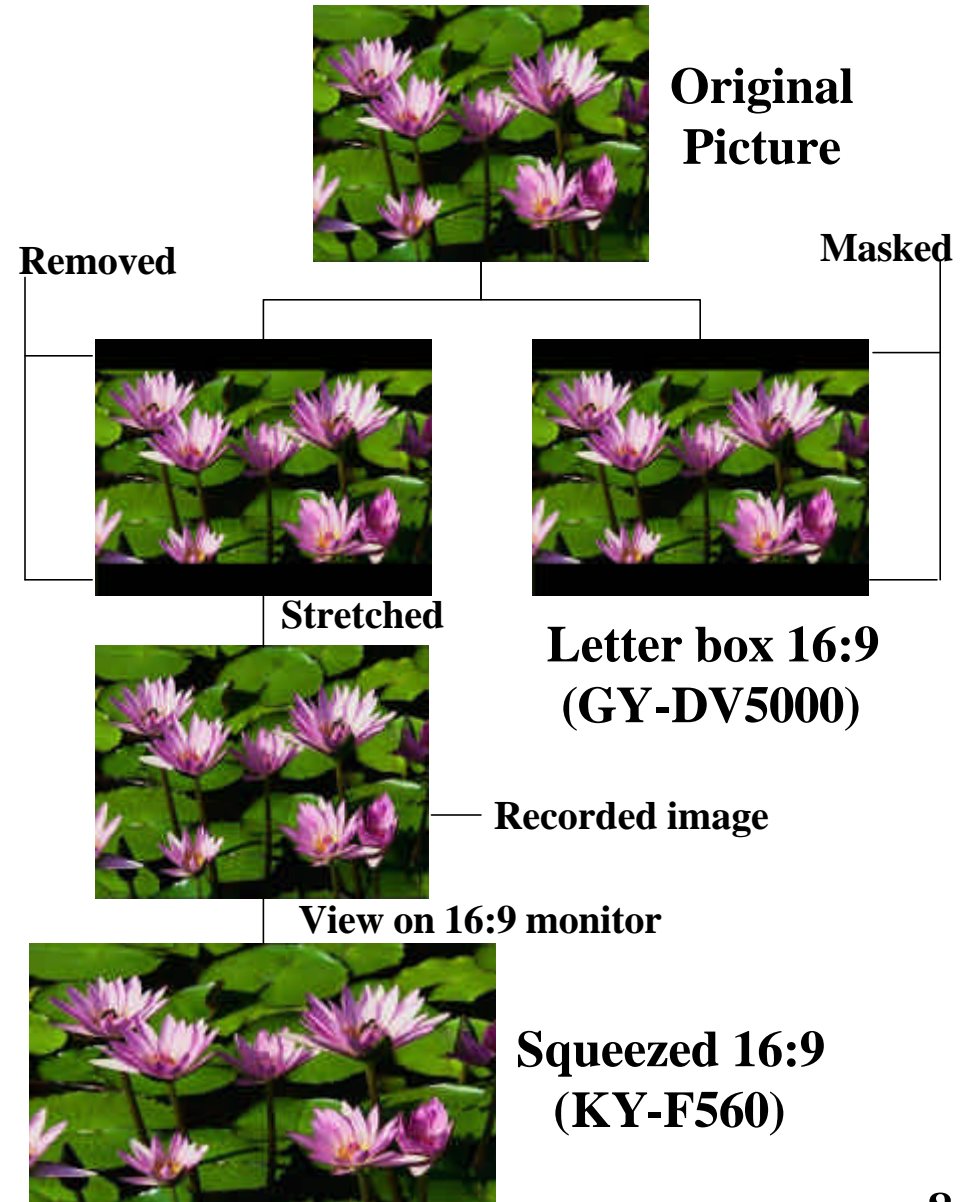

KY-F560 System Configuration

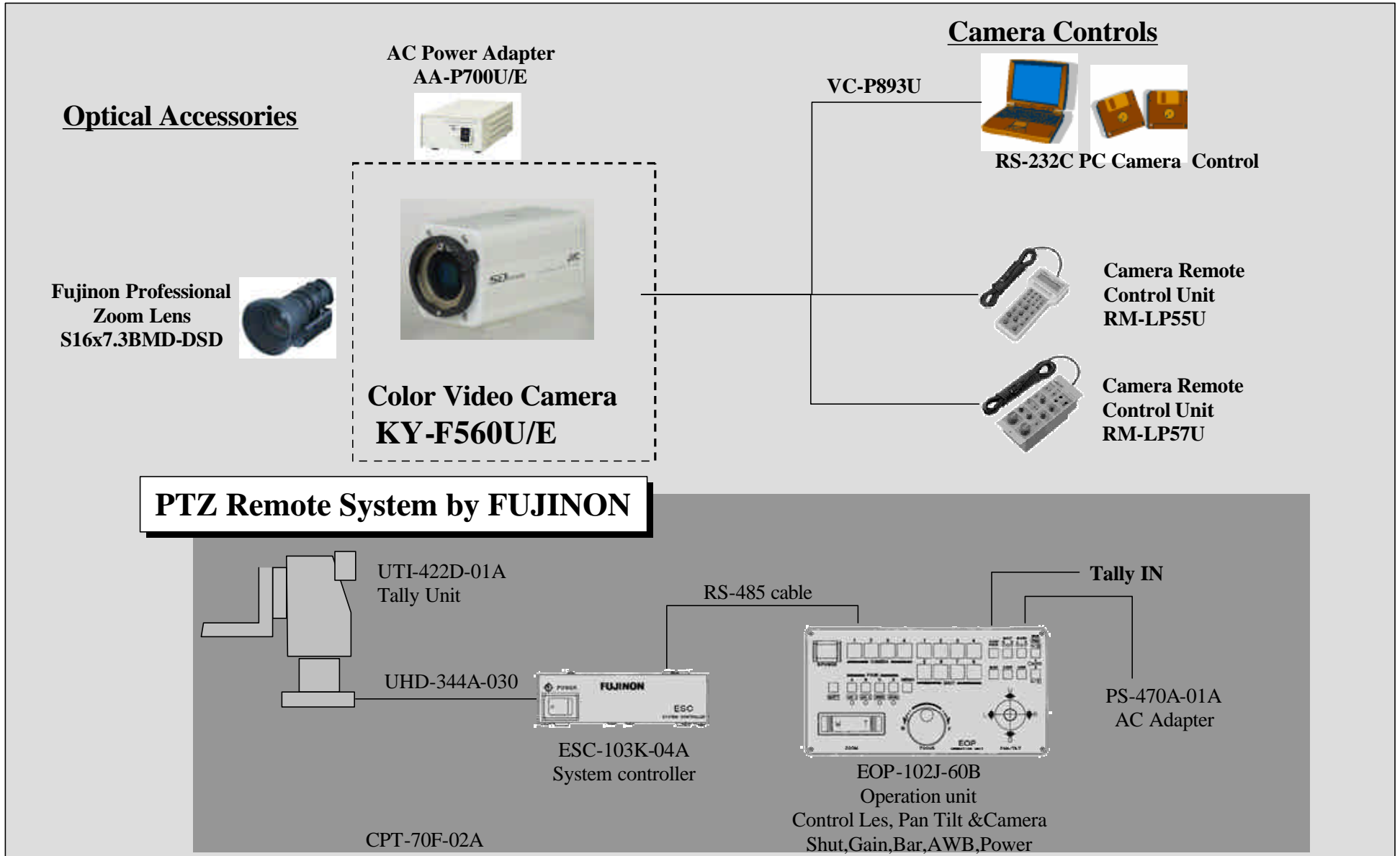

Fujinon PTZ Controller

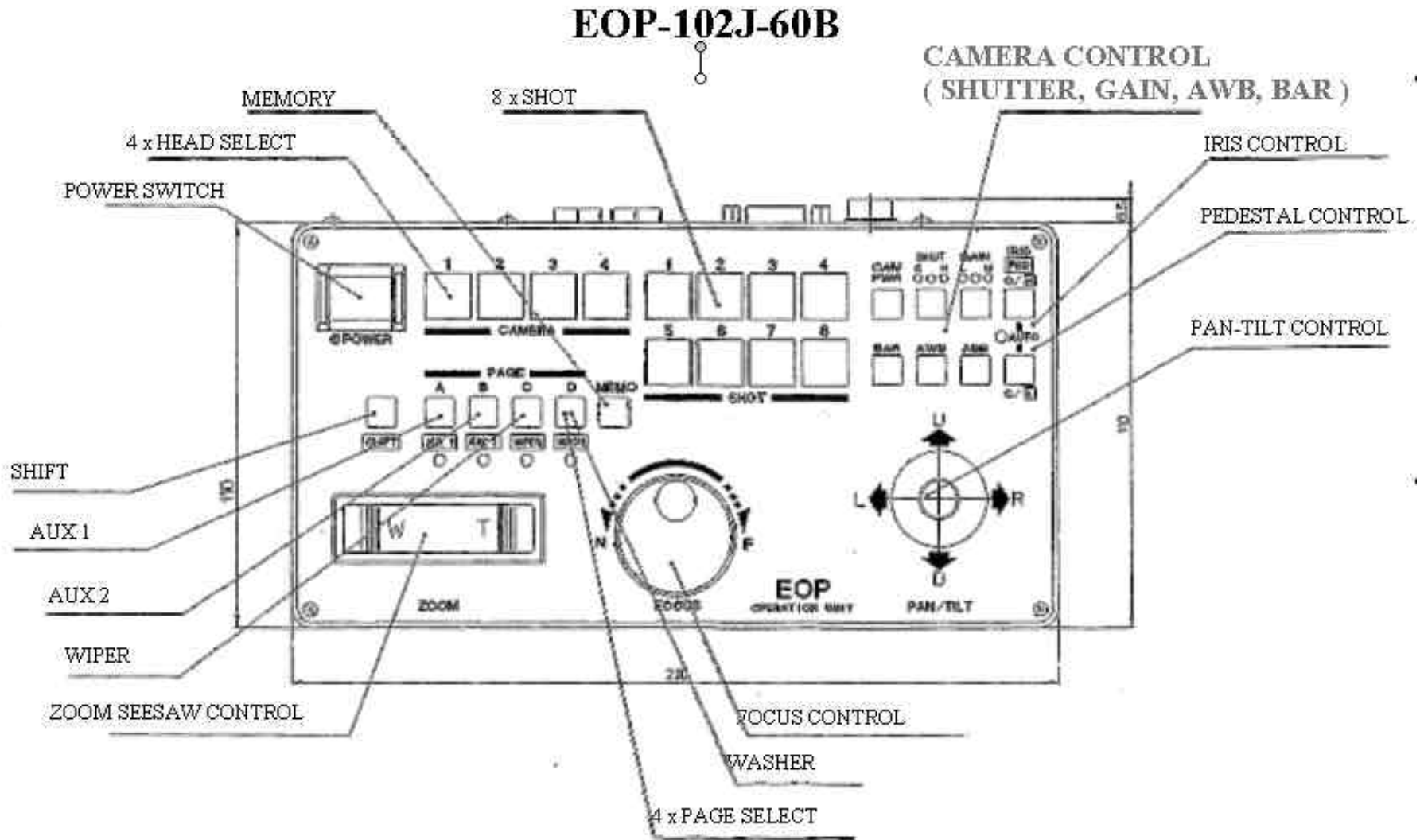

Fujinon PTZ Head with tally lamp

CPT-70F-02A/UTU-427D-01A

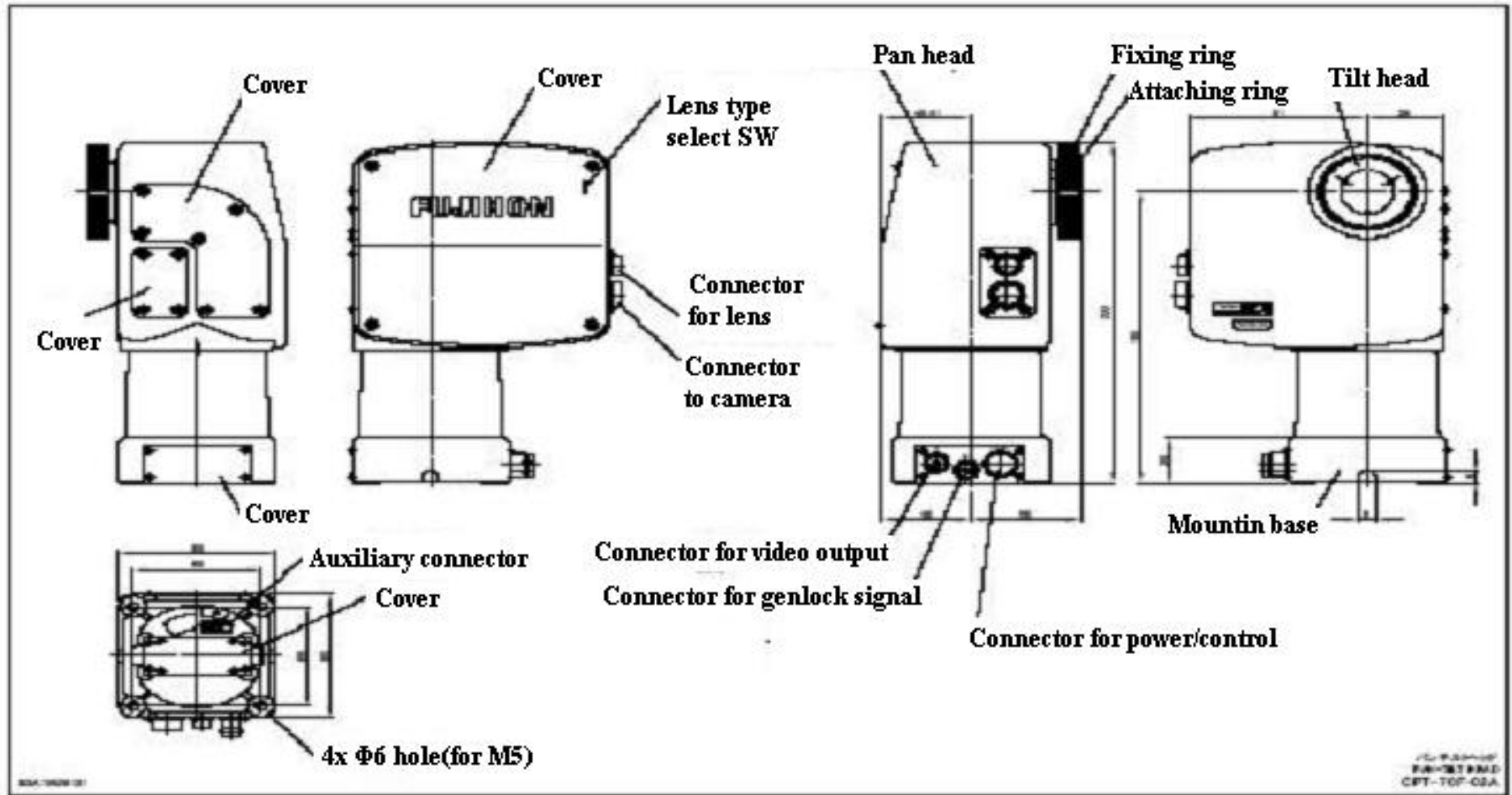

Fujinon PTZ System Controller

ESC-103K-04A

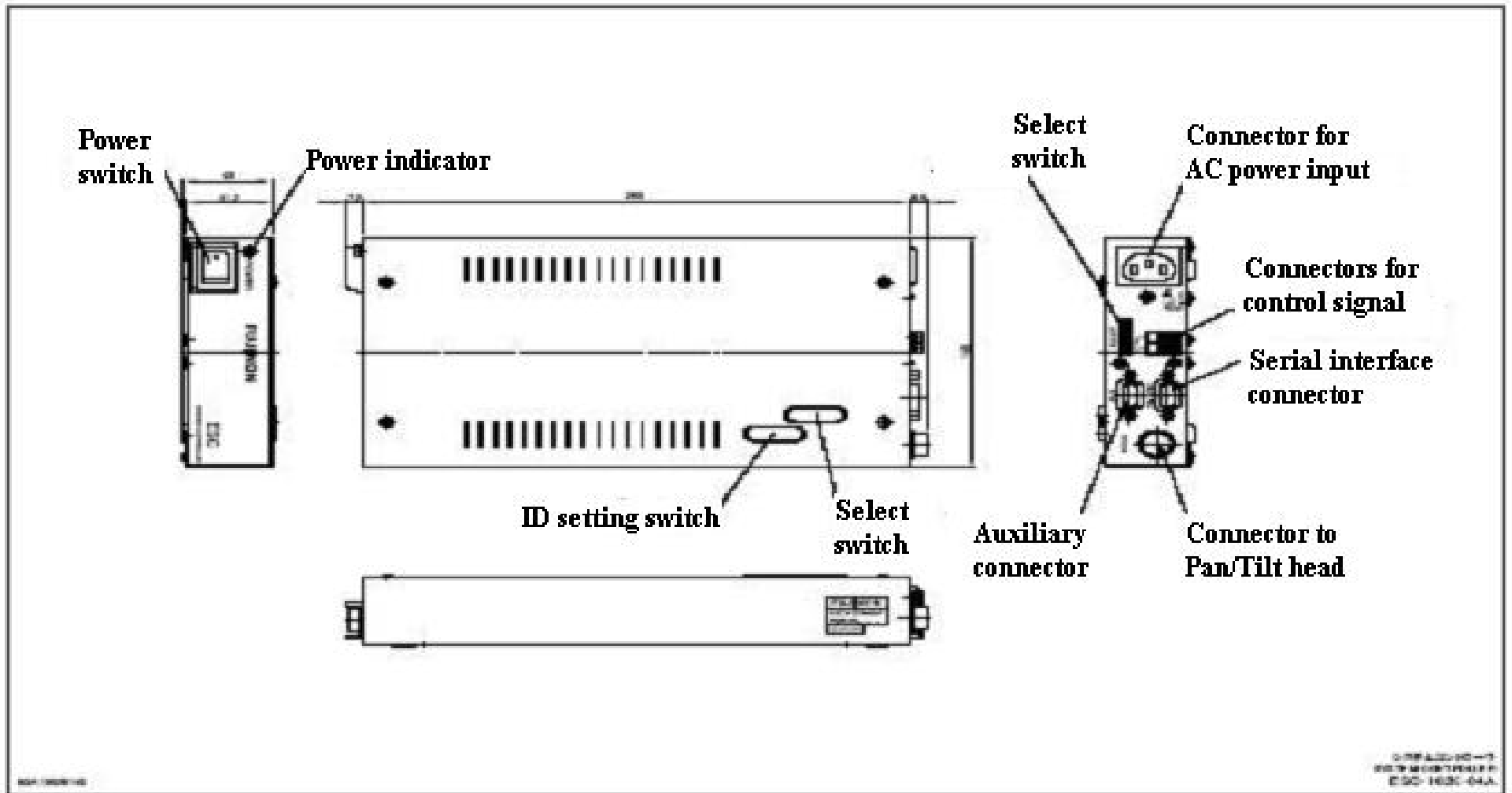

KY-F560 PTZ System Configuration with tally unit

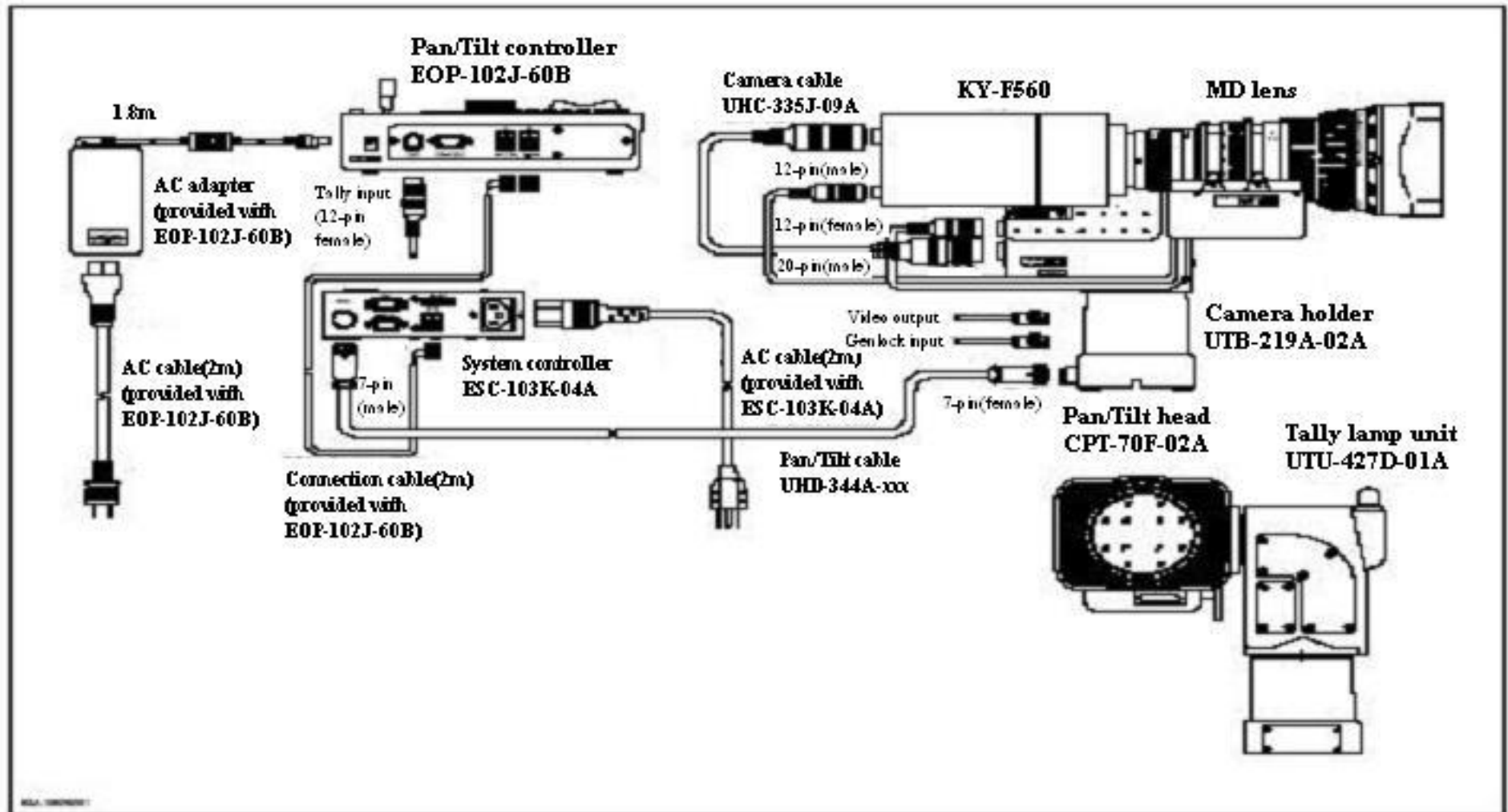

KY-F560 PTZ System Configuration(4 camera control)

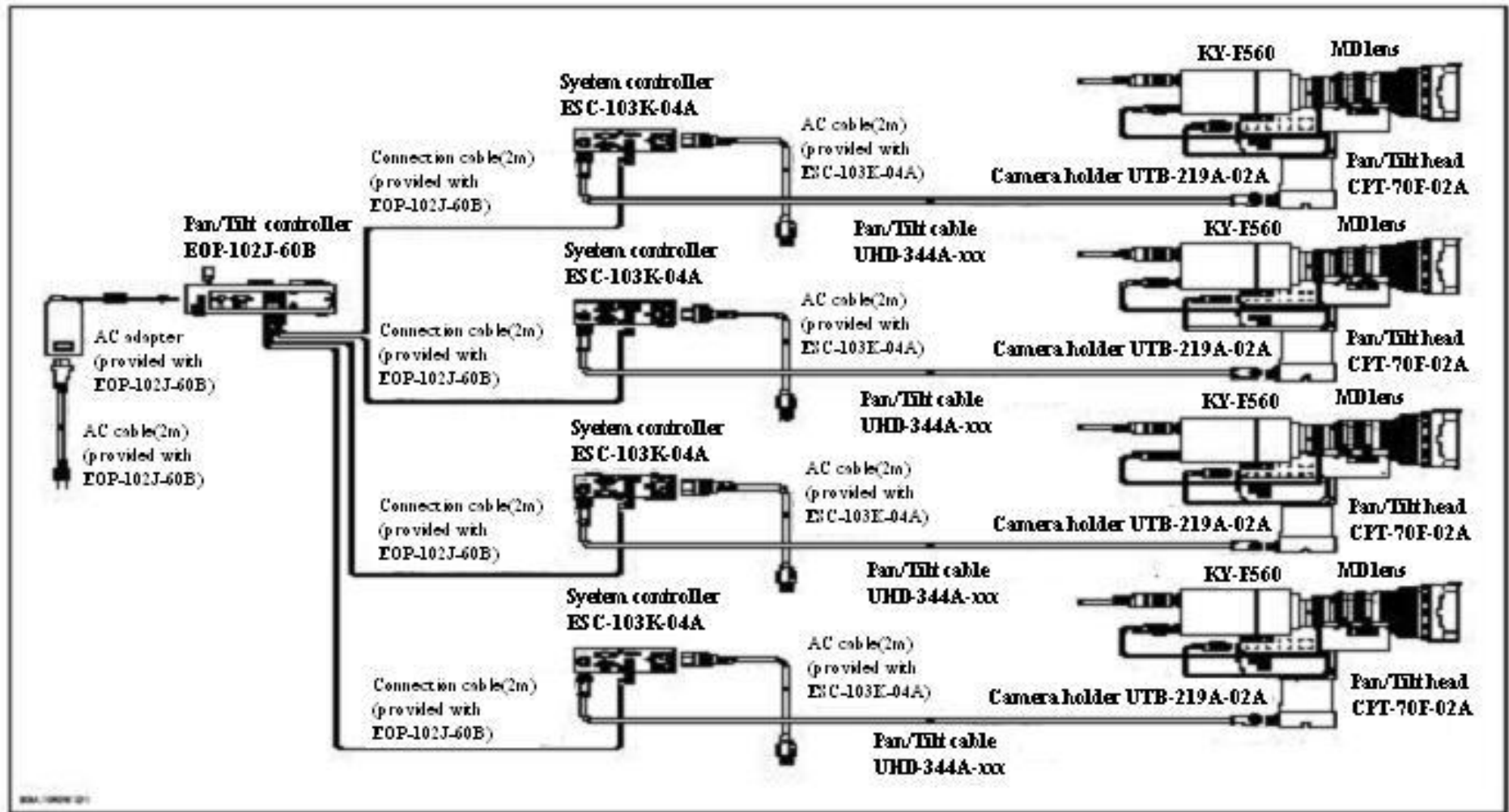

Comparison of PTZ system between KY-F560 & AW-E600



Configuration	JVC	Pana
Camera	KY-F560	AW-E600
Lens	YH19x6.7KTS	YH19x6.7KTS
PTZ housing	CPT-70F-02A/UTB-219A-02A UTU-427D-01	AW-PH300A
Controller	EOP-102J-60B	AW-RP501



	JVC	Pana
Power supply	Power is supplied via exclusive multi core cable from AC adapter. The connector of this cable is reliable with lock mechanism and easy to connect and disconnect.	Power is supplied via simple twist pair cable from AC adapter. But, this cable looks cheap and is unreliable without any connector and is recommended to be fixed by soldering.
Zoom, Focus and PT levers	The style of levers for Zoom, Focus and Pan/Tilt are different each other and is easy to operate ergonomically.	The style of levers for Zoom, Focus and Pan/Tilt is completely identical and easy to misoperate.
Menu setting	Menu cannot be adjusted from remote controller, but it is possible to set locally without any restriction.	Menu cannot be adjusted from remote controller. Moreover, if remote interface cable is connected, it also does not work. In order to set menu locally, it is necessary to provide power from another AC adapter. It is very inconvenient.
Tally indication	Optional tally is located at the top of PTZ and is large and visible from every direction regardless of the position of camera. Tally signal line is included in the multi core cable and no necessary to connect another line.	Provided tallies are located at the front and back of PTZ. But, both are too small and may not be visible when the camera covers it. And, it is required to connect another lines.
Shutter mode	Shutter modes can be selected from controller except 1/100(120) mode.	Shutter select items are 1/100(120) and EEL only from controller.
Genlock	Genlock can be adjusted locally only.	Genlock can be adjusted from controller.
Speed override	Manual operation is only possible to adjust the speed of each levers.	Speed select switch is useful to control each levers at lower or higher speed smoothly.
Iris adjustment	Manual iris can be adjusted by button step by step.	Manual Iris can be adjusted by volume variably and smoothly.
Cable clamp	No cable clamp adjustment	Cable clamp adjustment is possible.
Scene file	No scene file on controller.	4 scene file memories are available on controller.
ABC	No ABC function.	ABC can be controlled from controller.
ATW memory	No ATW memory	2 ATW memories are available on controller.
Tally indication on controller	No tally indication on controller.	Tally indication can be confirmed on controller.

KY-F560 Options

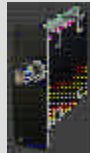

**SDI output Card
KA-F5601U**



**Color Video Camera
KY-F560U/E**



**Studio adapter
Analogue Component
KA-F5602U**



**Studio adapter
Analogue Component + SDI output
KA-F5603U**



**Remote Control Unit
RM-P210U/E**

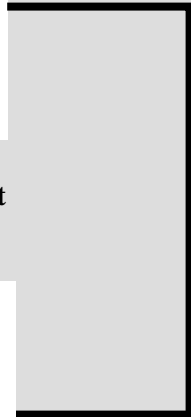

Studio Adapter KA-F5602(Analog)/F5603(Analog +

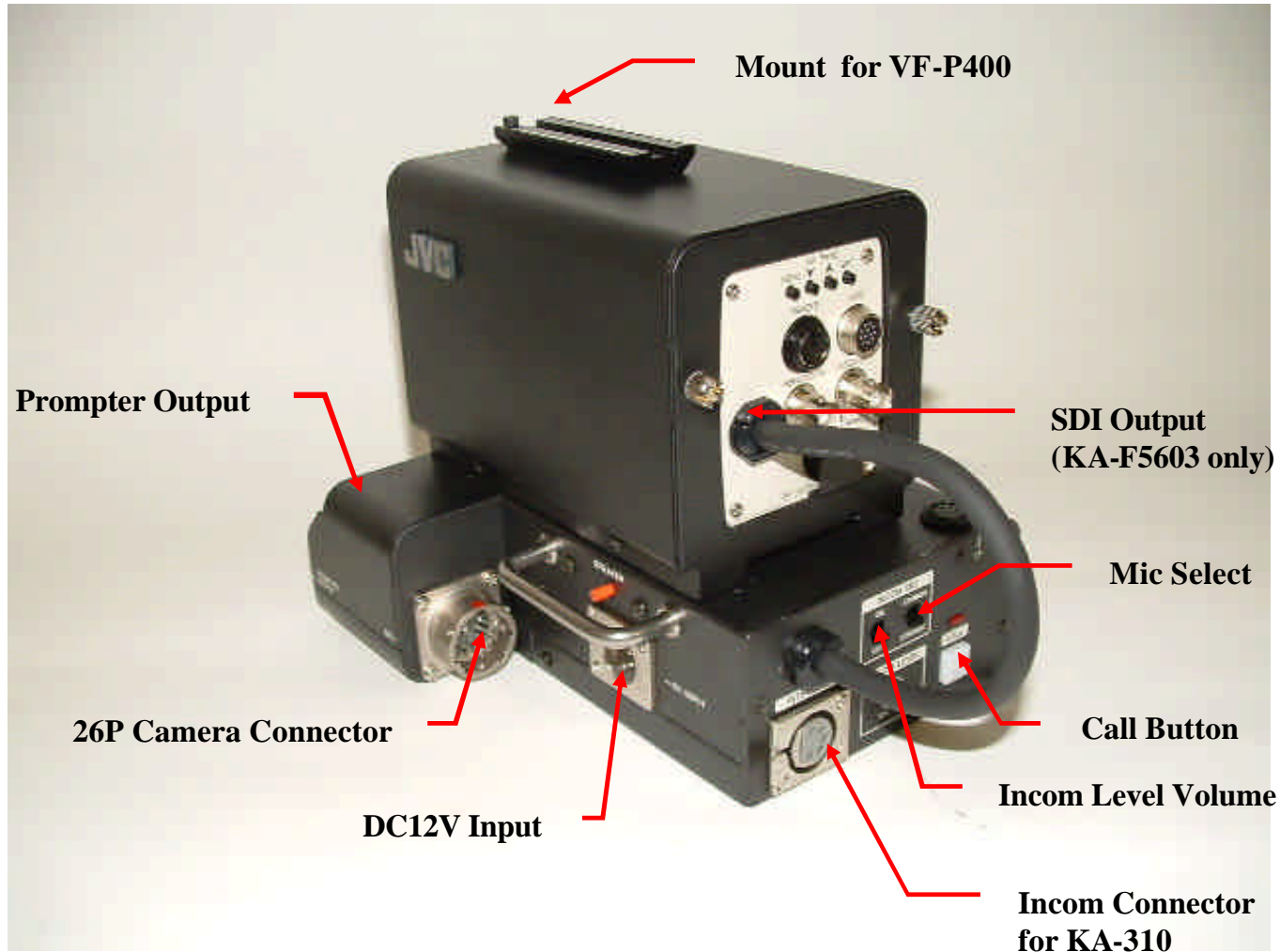

KY-F560 System Configuration 1

*When camera control is required

*When camera position is fixed

S16x7.3BMD etc
Fujinon MD lens

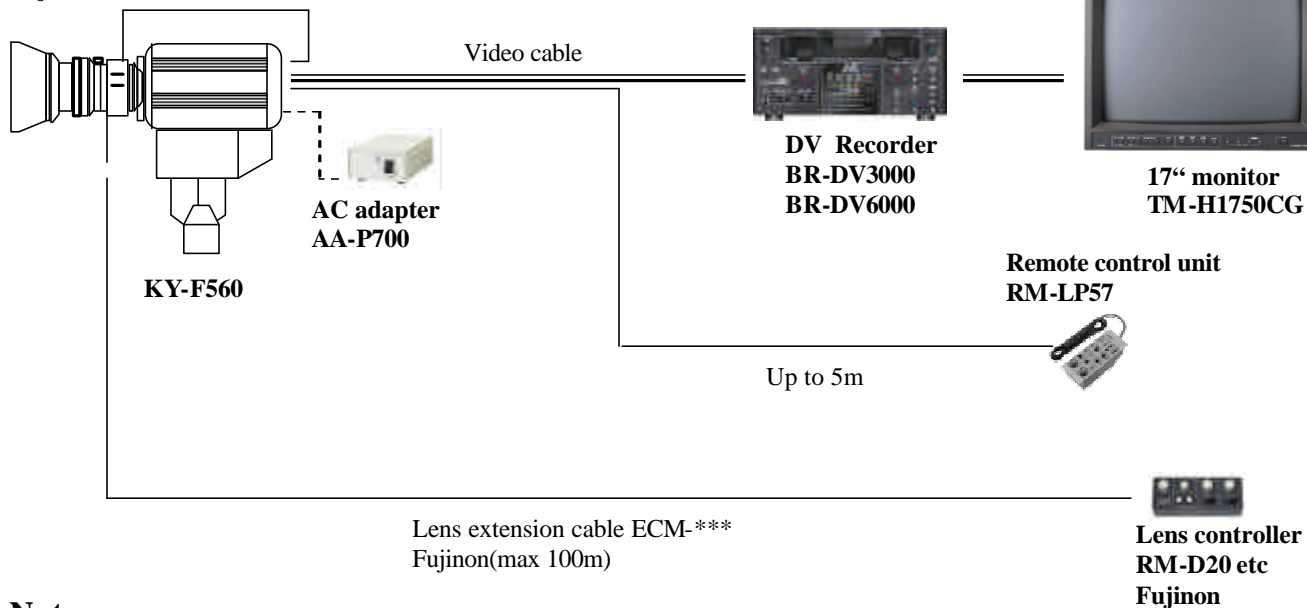

Note:

When the only camera part of KY-F560 is swapped from KY-F32 and Fujinon CPT-70F-02A PTZ system is not used, another lens controller and extension cable is required instead of RM-713MD

Fujinon:RM-D10/D20/D30 and exclusive extension cable

Canon:TCR-101F/201F/301F and exclusive extension cable

Model	Description	
KY-F560	3CCD color video camera	1
BR-DV6000	DV video cassette recorder	1
TM-H1750CG	17" monitor	1
AA-P700	AC power adapter	1
RM-LP57	Camera control unit	1
S16x7.3BMD-DSD	16x MD lens	1
RM-D20	Lens remote controller	1
ECM-020M	Lens extension cable(20m)	1

High picture quality generated by KY-F560 can be captured up to 4.5 hours onto DV recorder.

Camera parameter can be adjusted by RM-LP57 camera control unit.

MD lens can be controlled by exclusive lens control unit separately.

KY-F560 System Configuration 3

***When precise camera parameter adjustment is required by remote**

***Note:** Remote connector on UHC-335J-09A is not connected to KY-F560. Instead, RM-LP57 is connected.

***When PTZ system is required**

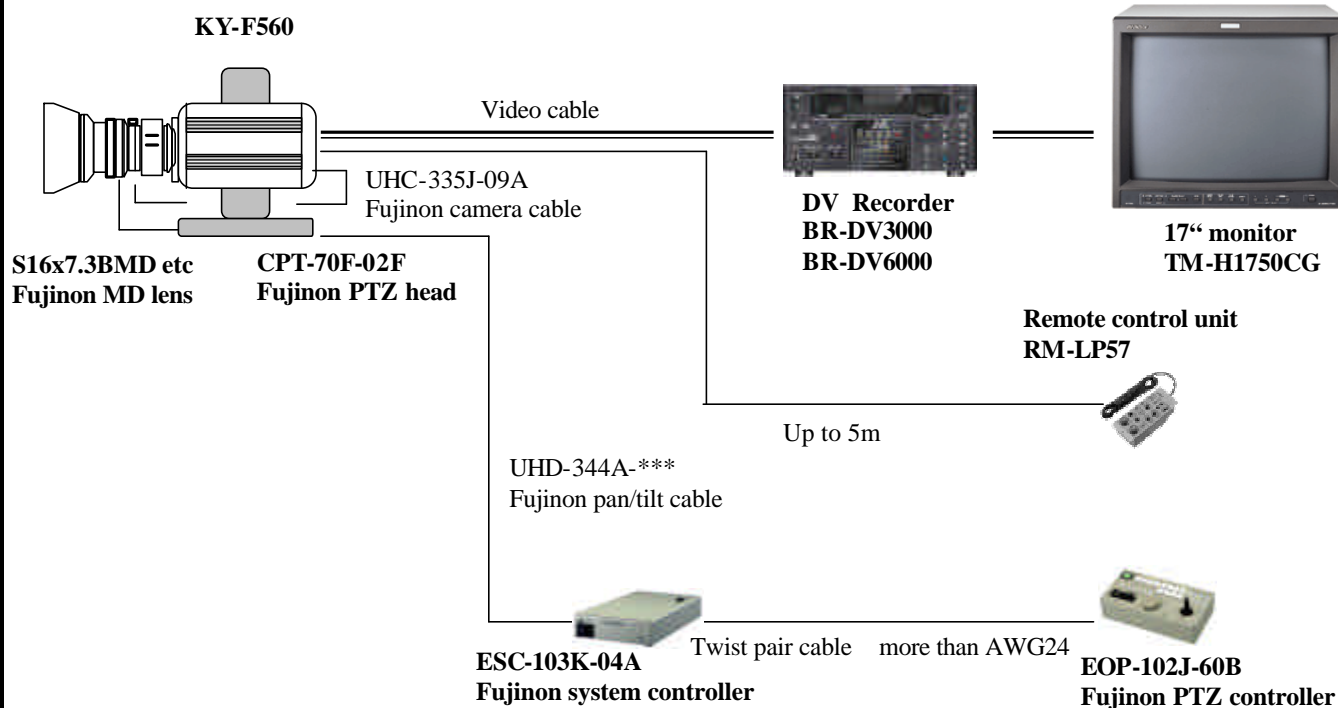

Model	Description	
KY-F560	3CCD color video camera	1
BR-DV6000	DV video cassette recorder	1
TM-H1750CG	17" monitor	1
RM-LP57	Camera control unit	1
S16x7.3BMD-DSD	16x MD lens	1
CPT-70F-02A	Pan/Tilt head	1
UTB-219A-02A	Camera adapter	1
UHD-344A-030	PTZ cable(30m)	1
ESC-103K-04A	System controller	1
EOP-102J-60B	PTZ controller	1
UHC-335J-09A	Camera cable	1

High picture quality generated by KY-F560 can be captured up to 4.5 hours onto DV recorder.

Camera parameter can be adjusted by RM-LP57 camera control unit

In conjunction with Fujinon PTZ system, 8 presets for lens pan/tilt/focus/zoom positions can be memorized. As a result, this camera system can be controlled to shoot preset location by remote as fast as possible.

Power supply from PTZ head to camera and power On/Off of the camera are possible.

KY-F560 System Configuration 4

***When camera control is required, but precise camera parameter adjustment is not required by remote**

***When PTZ system is required**

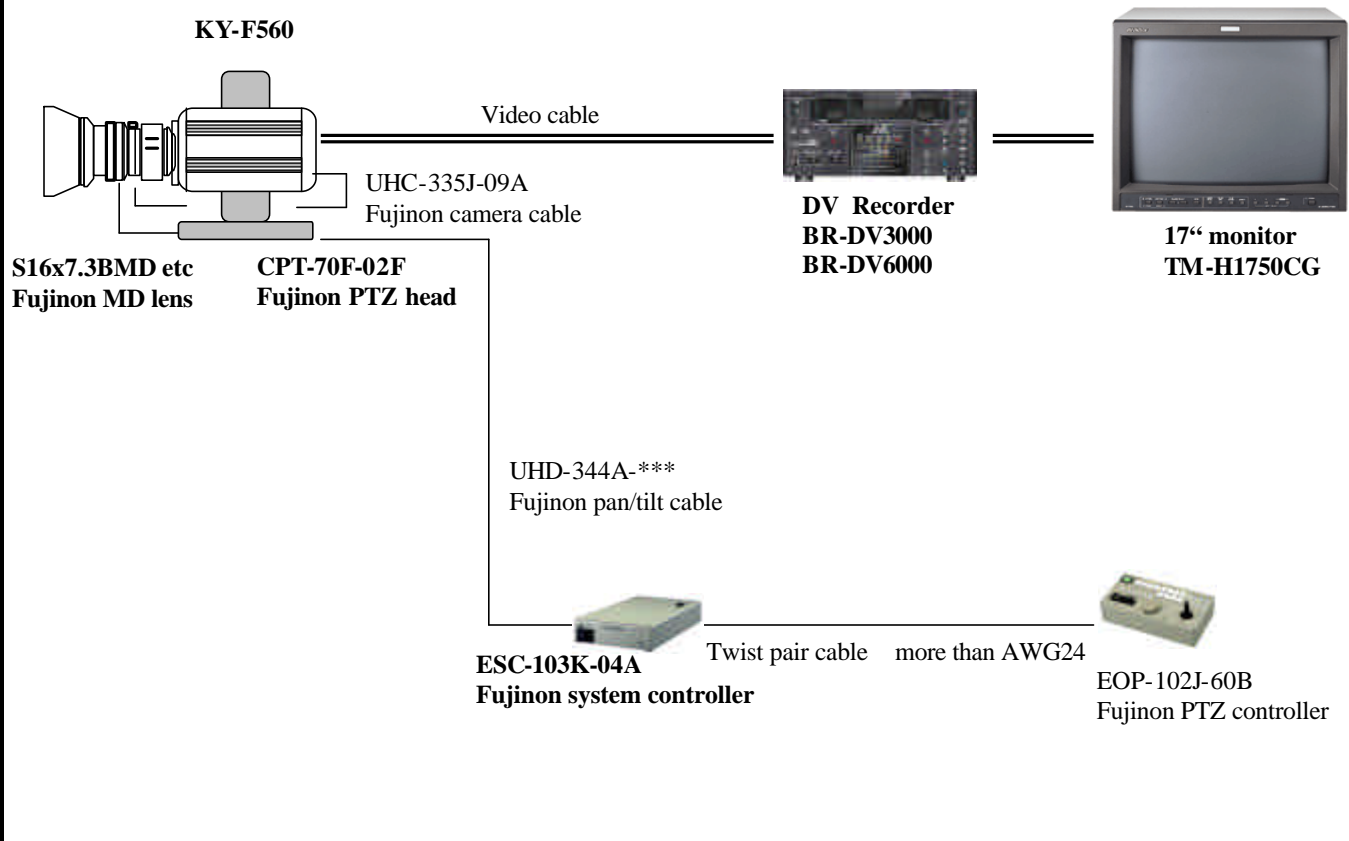

Model	Description	
KY-F560	3CCD color video camera	1
BR-DV6000	DV video cassette recorder	1
TM-H1750CG	17" monitor	1
S16x7.3BMD-DSD	16x MD lens	1
CPT-70F-02A	Pan/Tilt head	1
UTB-219A-02A	Camera adapter	1
UHD-344A-030	PTZ cable(30m)	1
ESC-103K-04A	System controller	1
EOP-102J-60B	PTZ controller	1
UHC-335J-09A	Camera cable	1

High picture quality generated by KY-F560 can be captured up to 4.5 hours onto DV recorder.

In conjunction with Fujinon PTZ system, 8 presets for lens pan/tilt/focus/zoom positions can be memorized. As a result, this camera system can be controlled to shoot preset location by remote as fast as possible.

Power supply from PTZ head to camera and power On/Off of the camera are possible.

KY-F560 System Configuration 5

***When precise camera parameter adjustment is required by remote**

*Note: Remote connector on UHC-335J-09A is not connected to KY-F560. Instead, RM-LP57 is connected.

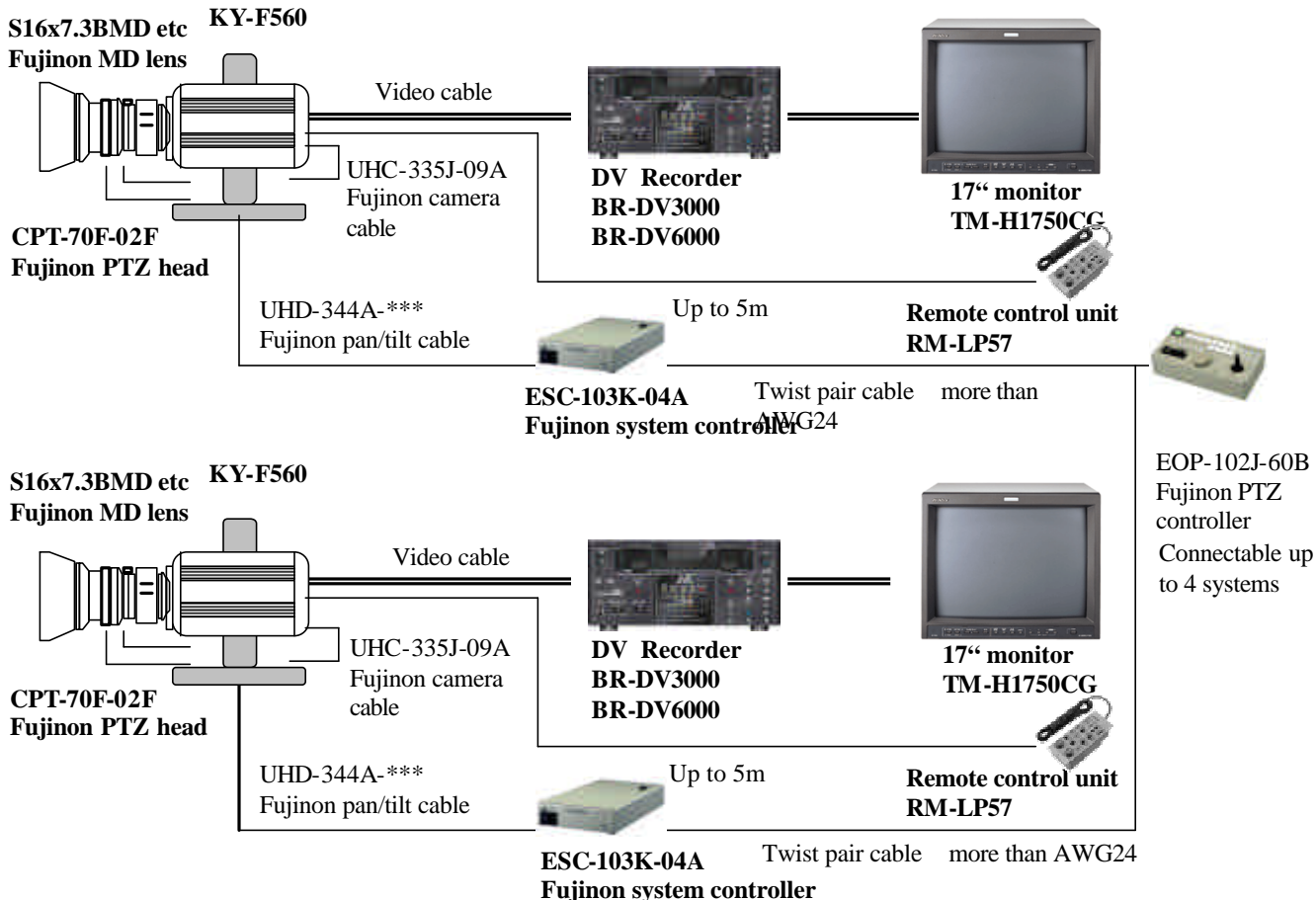

Model	Description	
KY-F560	3CCD color video camera	4
BR-DV6000	DV video cassette recorder	4
TM-H1750CG	17" monitor	4
RM-LP57	Camera control unit	4
S16x7.3BMD-DSD	16x MD lens	4
CPT-70F-02A	Pan/Tilt head	4
UTB-219A-02A	Camera adapter	4
UHD-344A-030	PTZ cable(30m)	4
ESC-103K-04A	System controller	4
EOP-102J-60B	PTZ controller	1
UHC-335J-09A	Camera cable	4

High picture quality generated by KY-F560 can be captured up to 4.5 hours onto DV recorder.

Camera parameter can be adjusted by RM-LP57 camera control unit

In conjunction with Fujinon PTZ system, up to 4 cameras can be controlled, and 8 presets for lens pan/tilt/focus/zoom positions for each camera can be memorized. As a result, this camera system can be controlled to shoot preset location by remote quickly.

Power supply from PTZ head to camera and power On/Off of the camera are possible.

KY-F560 System Configuration 6

***When camera control is required, but precise camera parameter adjustment is not required by remote**

***Note:** Remote connector on UHC-335J-09A is not connected to KY-F560. Instead, RM-LP57 is connected.

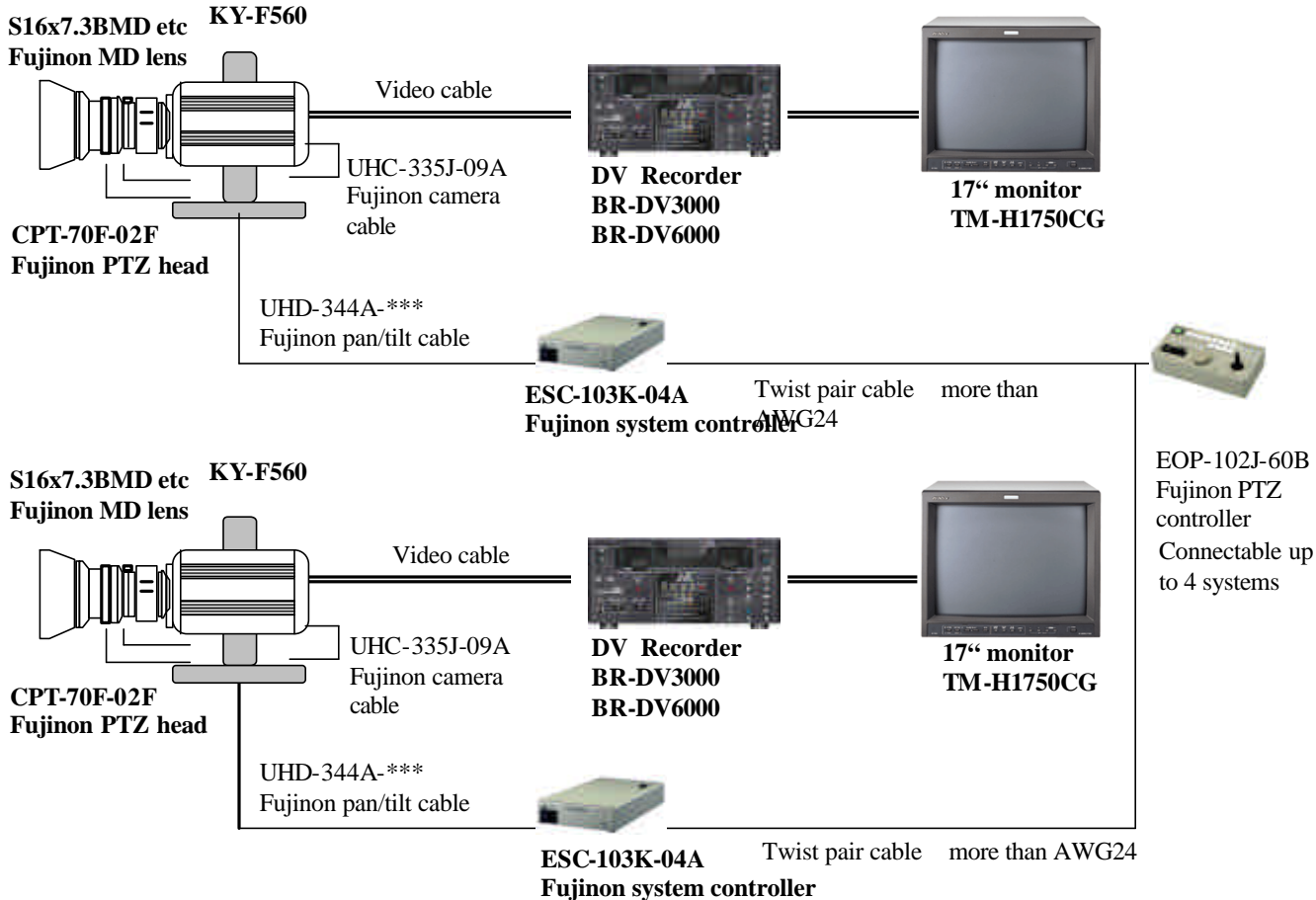

Model	Description	
KY-F560	3CCD color video camera	4
BR-DV6000	DV video cassette recorder	4
TM-H1750CG	17" monitor	4
S16x7.3BMD-DSD	16x MD lens	4
CPT-70F-02A	Pan/Tilt head	4
UTB-219A-02A	Camera adapter	4
UHD-344A-030	PTZ cable(30m)	4
ESC-103K-04A	System controller	4
EOP-102J-60B	PTZ controller	1
UHC-335J-09A	Camera cable	4

High picture quality generated by KY-F560 can be captured up to 4.5 hours onto DV recorder.

In conjunction with Fujinon PTZ system, up to 4 cameras can be controlled, and 8 presets for lens pan/tilt/focus/zoom positions for each camera can be memorized. As a result, this camera system can be controlled to shoot preset location by remote quickly.

Power supply from PTZ head to camera and power On/Off of the camera are possible.

KY-F560 System Configuration 7

*Analogue studio system configuration

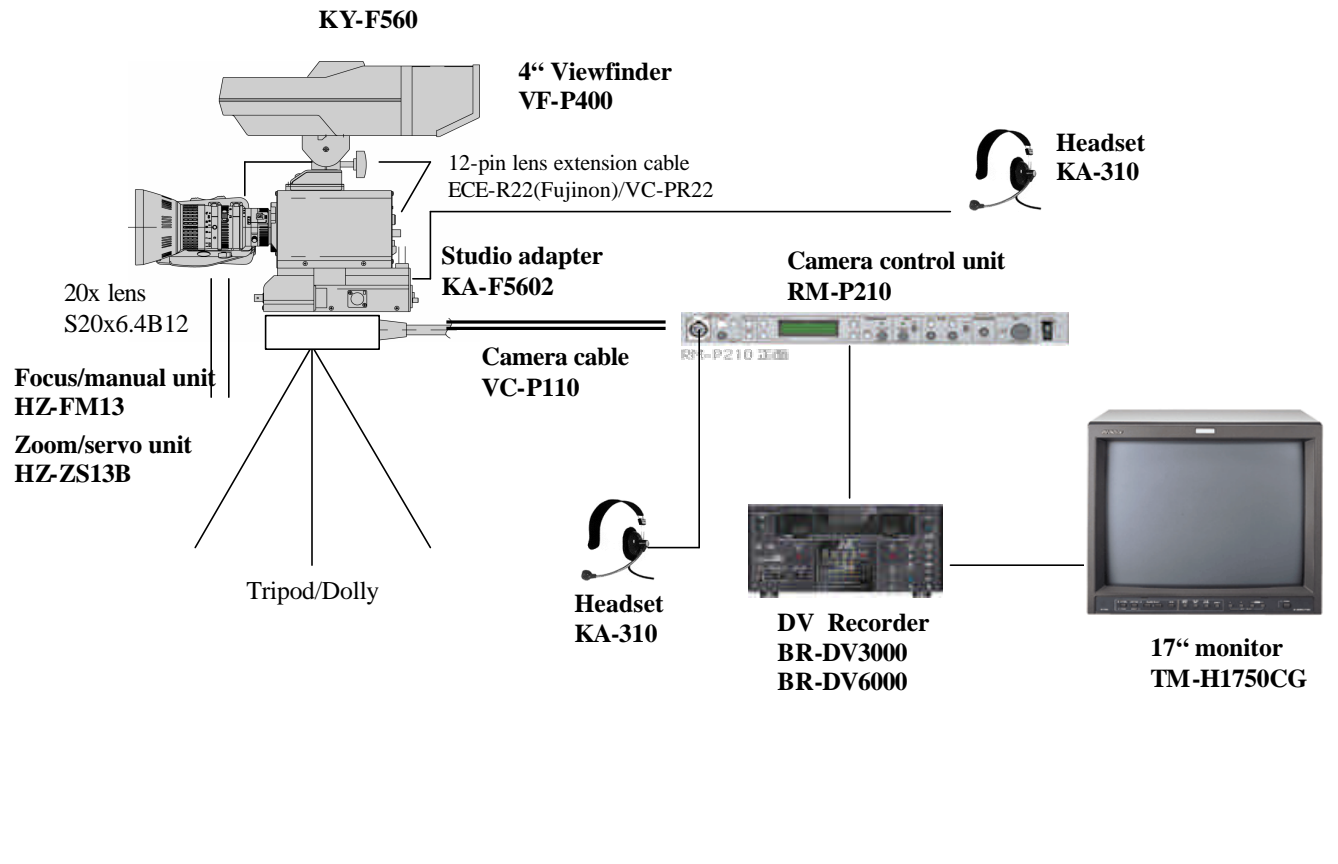

Model	Description	
KY-F560	3CCD color video camera	1
KA-F5602	Studio adapter	1
BR-DV6000	DV recorder	1
S20x6.4B12	20x lens	1
HZ-ZS13B	Zoom/servo unit	1
HZ-FM13	Focus/manual unit	1
VF-P400	4" Viewfinder	1
RM-P210	Camera control unit	1
VC-P110	Camera cable(10m)	1
TM-H1750CG	17" monitor	1
KA-310	Headset	2
	Tripod	1
	Dolly	1
ECE-R22/VC-PR22	Lens extension cable	1

The combination of KY-F560 with Studio adapter KA-F5602 can be connected to Camera control unit

The camera system can be controlled and the power of camera can be supplied from RM-P210 up to 100m.

This system consists of 4" view finder, focus/manual unit and zoom/servo unit equivalent to full studio camera.

Intercom and tally communications are also possible.

KY-F560 System Configuration 8

*Studio system configuration with SDI Output

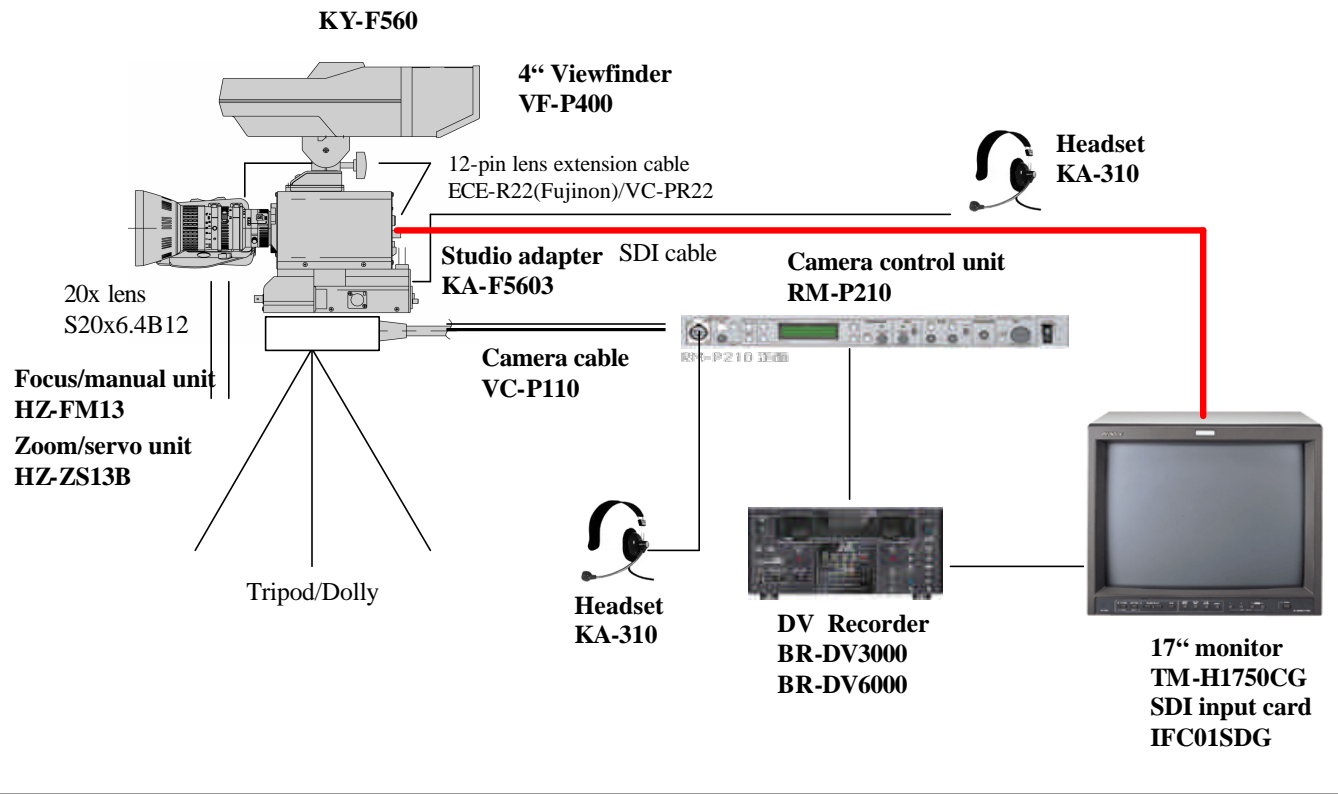

Model	Description	
KY-F560	3CCD color video camera	1
KA-F5603	Studio adapter with SDI output	1
BR-DV6000	DV recorder	1
S20x6.4B12	20x lens	1
HZ-ZS13B	Zoom/servo unit	1
HZ-FM13	Focus/manual unit	1
VF-P400	4" Viewfinder	1
RM-P210	Camera control unit	1
VC-P110	Camera cable(10m)	1
TM-H1750CG	17" monitor	1
IF-C01SDG	SDI input card	1
KA-310	Headset	2
	Tripod	1
	Dolly	1
ECE-R22/VC-PR22	Lens extension cable	1

The combination of KY-F560 with Studio adapter KA-F5603 can be connected to Camera control unit

The camera system can be controlled and the power of camera can be supplied from RM-P210 up to 100m.

This system consists of 4" view finder, focus/manual unit and zoom/servo unit equivalent to full studio camera.

Intercom and tally communications are also possible.

Additionally, SDI signal from KA-F5603 is available to connect to in-house master signal source.

KY-F560 System Configuration 9

*Fixed camera configuration with SDI Output

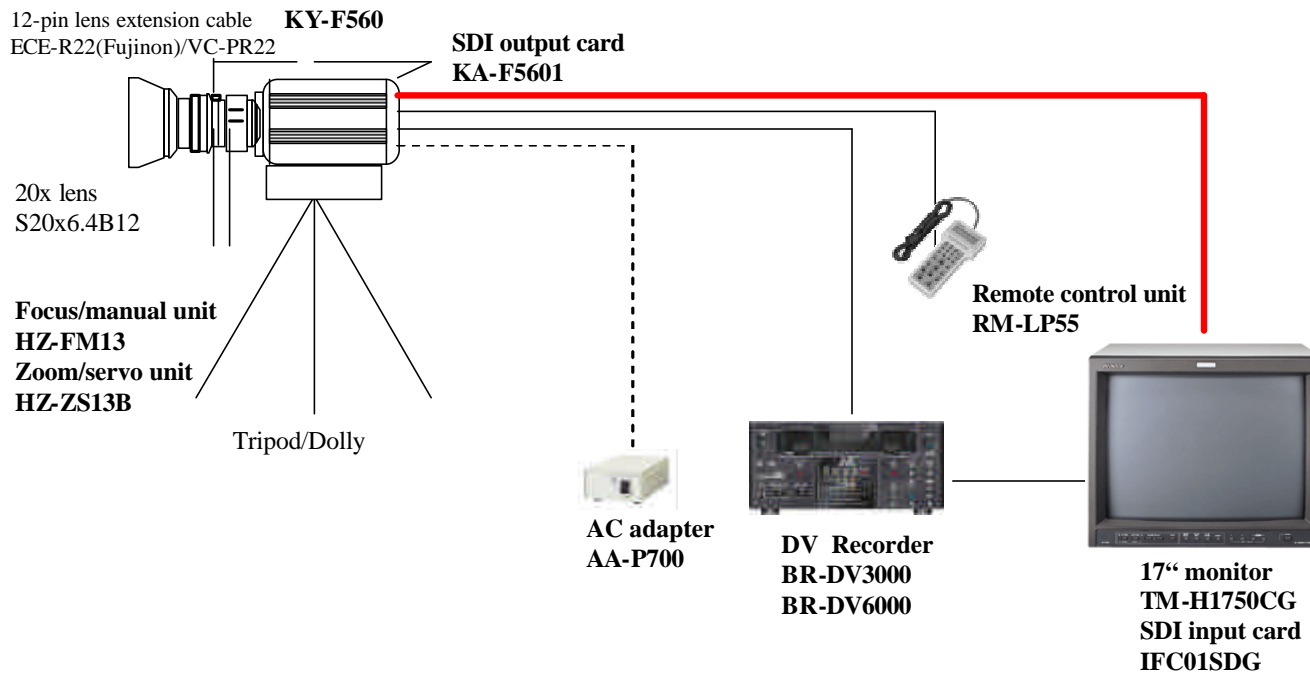

Model	Description	
KY-F560	3CCD color video camera	1
KA-F5601	SDI output card	1
BR-DV6000	DV recorder	1
S20x6.4B12	20x lens	1
HZ-ZS13B	Zoom/servo unit	1
HZ-FM13	Focus/manual unit	1
RM-LP55	Camera control unit	1
AA-P700	AC adapter	1
TM-H1750CG	17" monitor	1
IF-C01SDG	SDI input card	1
	Tripod	1
	Dolly	1
ECE-R22/VC-PR22	Lens extension cable	1

High quality video signal consisting of SDI signal can be output from KA-F560 and KA-F5601 SDI card combination.

KY-F560 Sample Application(Remote Camera)

Market/Application Live from Congress, Record for Wedding
 Record for Preaching in Church, Lesson in Univ., Simple Studio in Local Station

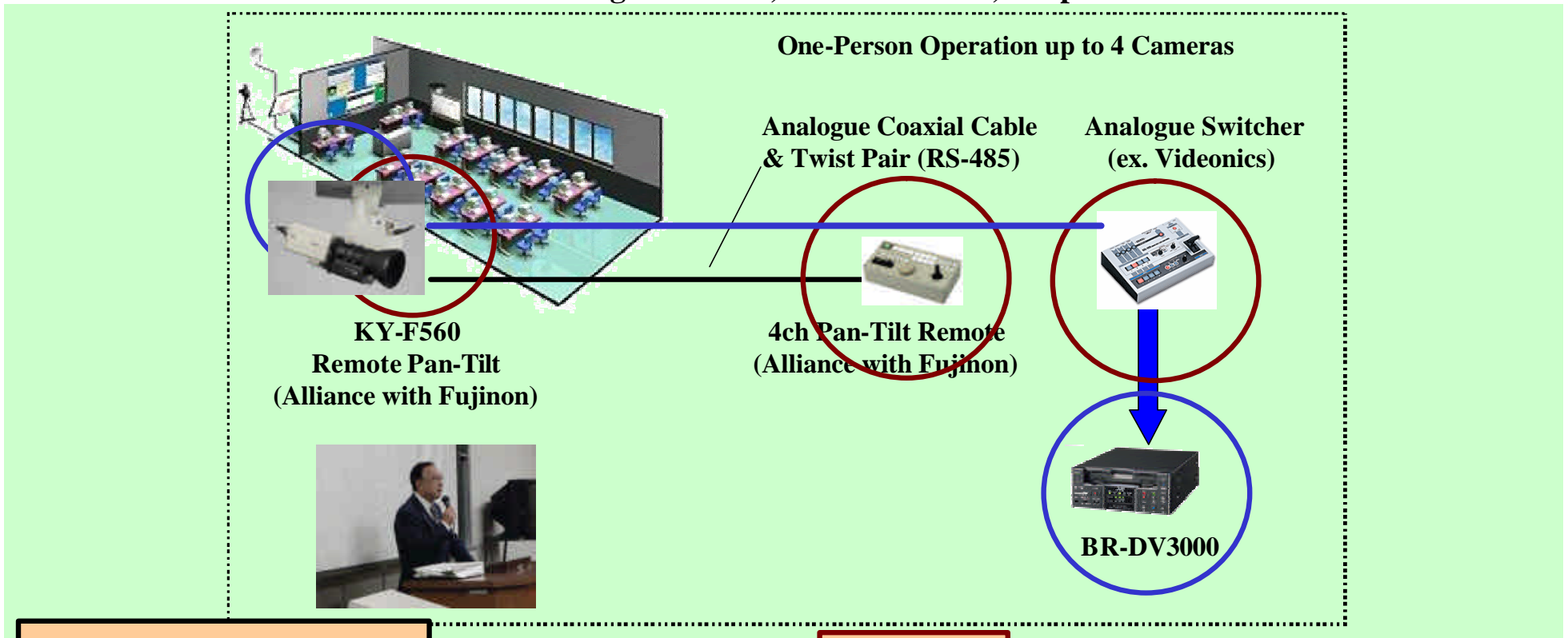

Customers' Requests

(Education)
 Simple operation and high quality image recording
 (Local Stations)
 One-Person operation studio

Solution

JVC can offer the KY-F560 itself in conjunction with the Pan-Tilt unit made by Fujinon to propose the total system as a solution.

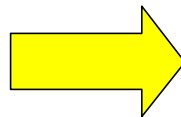

KY-F560 Comparison

Manufacturer	JVC	JVC	Panasonic	SONY
Model name	KY-F560	KY-F32	AW-E600	DXC-990
Dimensions (W x H x D)	70×80×153mm	70×80×164mm	84×77×155mm	70×72×123.5mm
Weight	800g	850g	860g	630g
Image device	1/2inch 3CCD	1/2inch 3CCD	1/2inch 3CCD	1/2inch 3CCD
Effective pixels	380,000(NTSC) 440,000(PAL)	380,000(NTSC) 440,000(PAL)	380,000(NTSC) 440,000(PAL)	380,000(NTSC) 440,000(PAL)
Color Separation	Trichromatic prism	Trichromatic prism	Trichromatic prism	Trichromatic prism
Lens mount	Bayonet mount	Bayonet mount	Bayonet mount	Bayonet mount
Sensitivity	F13/ 2000lx	F9.5/ 2000lx	F11/ 2000lx	F11/ 2000lx
Min. Illumination	F1.4 /0.7lx(Lolux 30dB)	F1.4/ 6lx	F1.4/ 0.25lx	F1.4/ 1lx
Horizontal Resolution	850 TVL	750 TVL	850 TVL	850 TVL
S/N ratio(NTSC/PAL)	64/62dB	60/58dB	65/63dB(DNR ON)	63/62dB
Quantisation	12bit	Analog	10bit	10bit
Automatic Level Control	Yes	Yes	Yes	Yes
Automatic Shutter Adjustment (EEI)	Yes	Yes	Yes	Yes
White Balance	Yes	Yes	Yes	Yes
Black Balance	Yes	Yes	Yes	Yes
Dynamic Shading	Manual(Vertical only)	Vertical only	Vertical only	Vertical only
Lens Control	Yes	Yes	Yes	Yes
MD control	No	Yes	No	No
Random Trigger	No	No	No	No
Sync input	Yes	Yes	Yes	Yes
Composite output	Yes	Yes	Yes	Yes
Y/C output	No	Yes	No	Yes
RGB output	No	Yes	option	Yes
Component output	No	Yes	option	Yes
DV output	No	No	option	No
Extender board slot	Yes	No	Yes	No

1/3" 3CCD Video Camera KY-F550U/E

Feature, Advantage:

- ✎ High Quality with 24bit A/D and 12bit DSP but Compact size
- ✎ High Sensitivity, F11/2000 lx
- ✎ Horizontal resolution 800lines, S/N 62(NTSC)/60(PAL)dB
- ✎ DV (IEEE1394) output
- ✎ Image capturing and camera control via IEEE1394 with provided DV-LINK software
- ✎ Removable IR Cut Filter
- ✎ Compatible with JVC KY-F55B series options



KY-F550 Cosmetic Image

Ultra compact! (66% of KY-F55B)

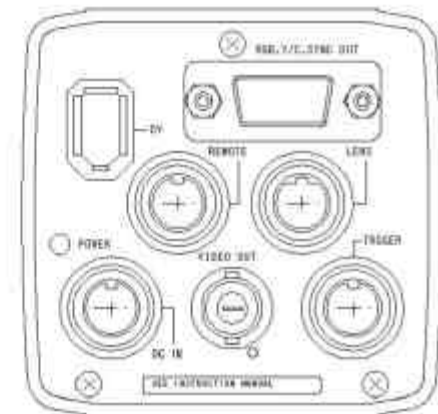
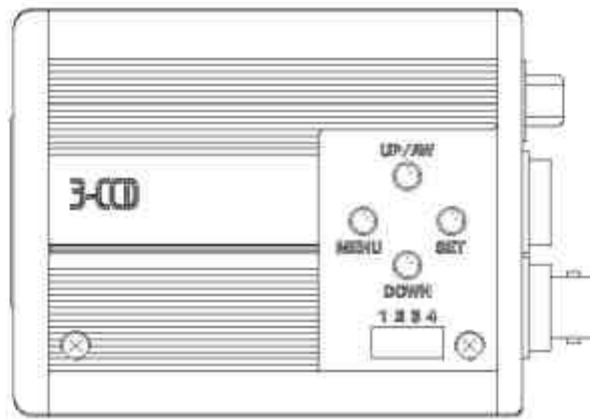
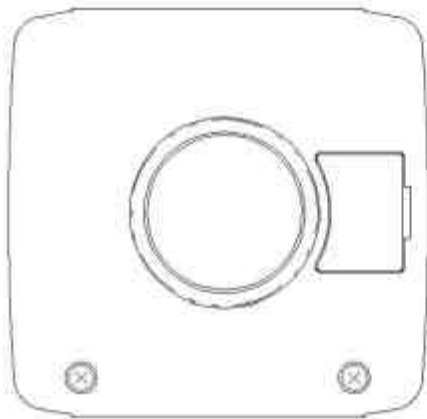

80mm

Difference between KY-F550 and KY-F55B

Comparison with KY-F55B

Model	KY-F550	KY-F55B
Dimensions(WxHxD)	70x65x80mm	70x80x133mm
Weight	380g	490g
Image size	1/3" 3CCD	1/3" 3CCD
Color separation	F1.4 RGB	F1.4 RGB
Lens mount	1/3" C-mount	1/3" C-mount
Sensitivity	F11/ 2000lx	F5.6/ 2000lx
Minimum illumination	F1.4/1 lx	F1.4/ 15lx
Horizontal resolution	800 lines	750 lines
S/N	62dB(NTSC)/60dB(PAL)	60dB(NTSC)/58dB(PAL)
Camera DSP	12bit ADC/24 bit DSP	Analog
ALC	Yes	Yes
EI	Yes	Yes
White balance	Yes	Yes
Dynamic shading	Auto/Manual(vertical only)	Manual(vertical only)
Random trigger	Yes	Yes
Genlock input	No	Yes
Composite output	Yes	Yes
Y/C output	Yes	Yes
RGB output	Yes	Yes
DV output	Yes	No
Back focus adjustment	No	Yes

Rear panel

KY-F550



New
DV output (6-pin)

KY-F55B



Delete
Genlock input

Difference between KY-F550 and KY-F55B

Comparison with KY-F55B

Side panel

KY-F550



KY-F55B

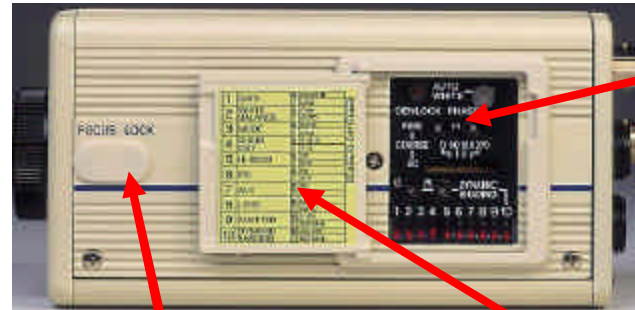

Delete

Genlock adjustment part

Delete

Back focus adjustment

Delete

Panel cover

No.	Function	ON	OFF
1	DV Output <i>*Note</i>	Compressed DV signal (IEEE1394) of the camera images will be output	DV signal will not be output.
2	DSUB Output	Y/C signal will be output	RGB signal will be output.
3	Sync On Green	Sync signal will be superimposed onto the G channel of the video signal output to the DSUB terminal.	Sync signal will not be superimposed.
4	Control mode	Operate the camera via DV terminal.	Operate the camera via the buttons on this unit or the remote control unit..

Note: If ON is selected, the analog output exhibits the same level of horizontal resolution (540 lines) as DV output.

KY-F550 Menu Setup Contents

AE Level	-5 to +5
AE Detect	Peak / Normal / AVG
AE Area	Full / Square / Spot / Normal(Top Cut) / Circle/Rectangle
Shutter	
Step	1/7.5(6.25), 1/15(12.5), 1/30(25), Normal, 1/100(120), 1/250, 1/500, 1/1000, 1/2000, 1/4000, 1/10000
ELC	Yes(EEL)
V.SCAN	1/60.1(50.1) to 1/10.1688k
V.Resolution	Normal(Field) / VMAX(Frame)
Gain	AGC, LIMIT(+9, +12, +15, +18dB) , LOLUX(30dB)
Master Black	-10 to +10
White Balance	FAW/PRESET(3200K)/ R Gain, B Gain: 0 to 255, AUTO1/AUTO2
Mode	
Freeze trigger	Alternative/Momentary
Image type	Field/Frame
Random shutter	1/60(50), 1/100(120), 1/250, 1/500, 1/1000, 1/2000, 1/4000, 1/10000

DV system	JVC/Others
Detail	OFF/MANUAL H/V balance:-5 to +5 Level:-10 to +10 Frequency:Low/Mid/High
Color Matrix	-3 to +3/STD/WARM/ /EXT1/EXT2/EXT3/OFF R Gain/R Rotation/G Gain/ G Rotation/B Gain/B Rotation
Gamma	-5 to +5, OFF, CINEMA
Knee	80% to 100%, Auto
White Clip	100%/108%
Flare	R/MASTER/B -10~ +10
Black	Stretch/Compress/OFF
Negative	Negative/Positive
Pixel Compensation	Execute/Cancel
Shading	Preset/Auto/Manual (R/G/B -128 to +127)
File Manage	A,B,C

KY-F550 Menu Setup by Remote Controller

Function	Local	By RM-LP55	By RM-LP57
MODE	Yes	Yes(CAM/BARS/NEGA)	Yes(CAM/BARS)
NEGA	Yes	Yes	No
CONTOUR	Yes	Yes(ON(LEVEL)/OFF)	Yes(ON(LEVEL)/OFF)
GAMMA	Yes	No	No
MASTER BLACK	Yes	Yes(LEVEL)	Yes
IRIS	Yes	Yes(AUTO(LEVEL)/MANU)	Yes(AUTO(LEVEL)/MANU)
IRIS DETECT	Yes	Yes(NORMAL/PEAK/AVG)	No
WHITE BALANCE	Yes	Yes(AUTO1/AUTO2/FAW/ MANUAL/PRESET)	Yes(AUTO1/AUTO2/FAW)
GAIN	Yes	Yes(-3/ 0/ 6/ 9/ 12/ 18dB/ ALC/ALC+EEI)	Yes(0/ 6/ 9/ 12/ 18dB/ ALC/ALC+EEI)
SHUTTER	Yes	Yes(NORMAL/ 1/100(120)/ 1/250 / 1/500/ 1/1000/ 1/2000/ V.SCAN/ EEI/ SLOW)	Yes(NORMAL/ 1/100(120)/ 1/250 / 1/500/ 1/1000/ 1/2000/ EE)
FILE	Yes	Yes	No
ZOOM	No	Yes	Yes (Note 1)
FOCUS	No	Yes	Yes (Note 1)
HI-RESO(Note 2)	Yes	Yes	No
WHITE SHADING	Yes	No	No

Note1:Operation is possible when connected to RM-713MD

Note2:Equivalent to V.RESOLUTION NORMAL:HI-RESO OFF, V.MAX:HI-RESO ON

KY-F550 System Configuration

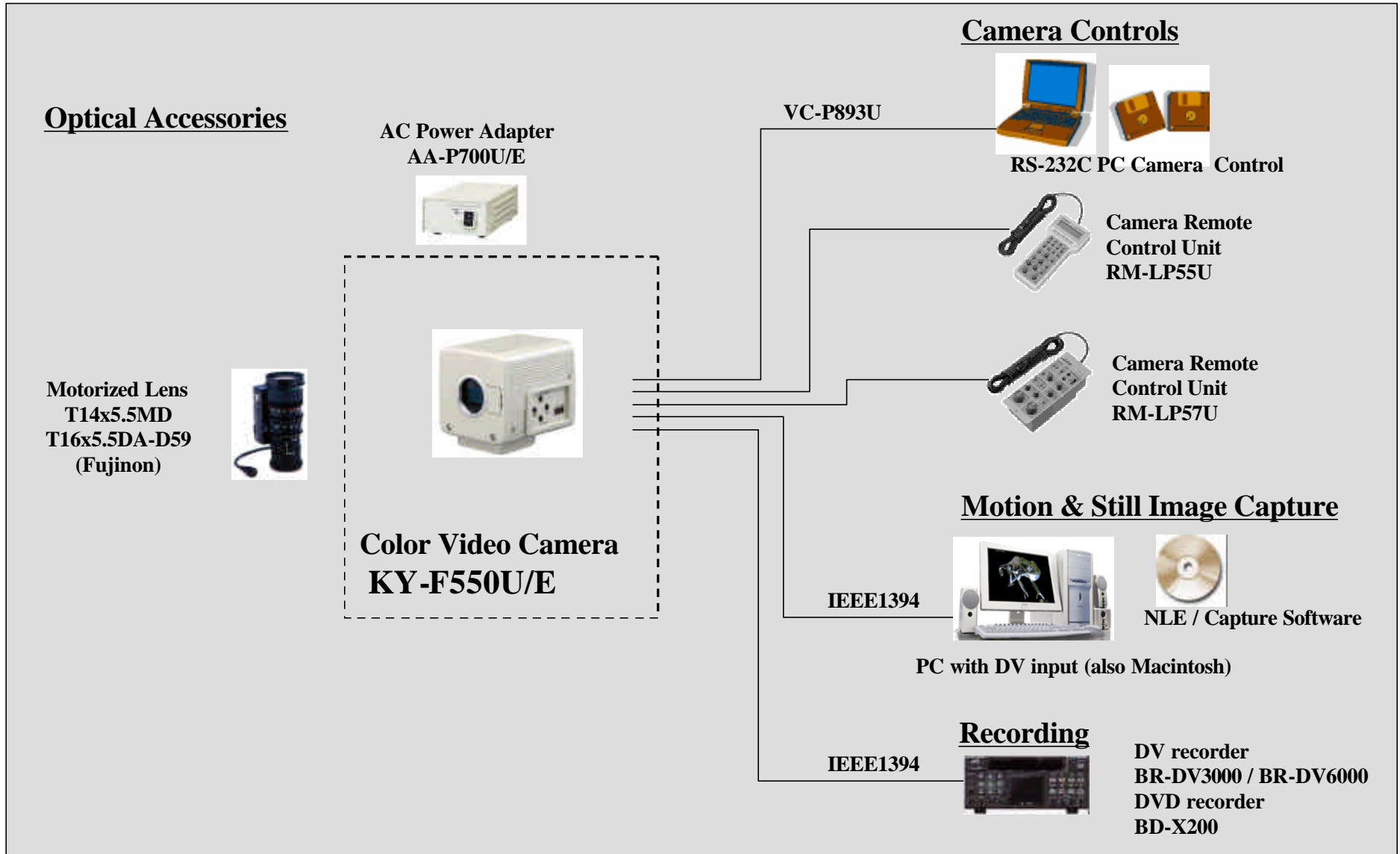

DV-LINK for KY-F550

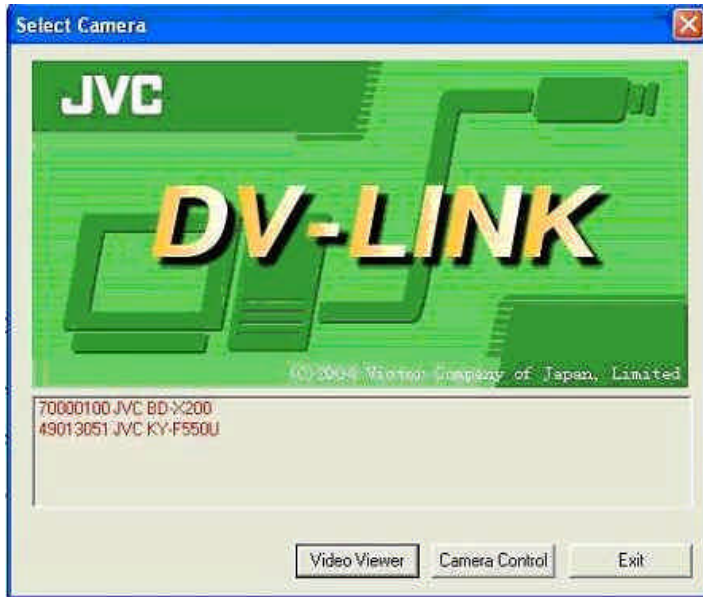

DV-LINK is a standard tool provided to the user of KY-F550 camera in order to use along with the camera. The application is based on KY-F550 1394 SDK supplied by JVC.

Major functions of DV-LINK

- ✍ **Control KY-F550 camera through IEEE1394 bus including function menu mode**
- ✍ **Display video data in PC with provision for recording**
- ✍ **View recorded avi files**
- ✍ **Provision for capture of still images (bmp format) during live and offline viewing of avi files**
- ✍ **Device control provision for BR-DV3000/ BR-DV6000 Professional DV recorder/ BD-X200 DVD recorder**

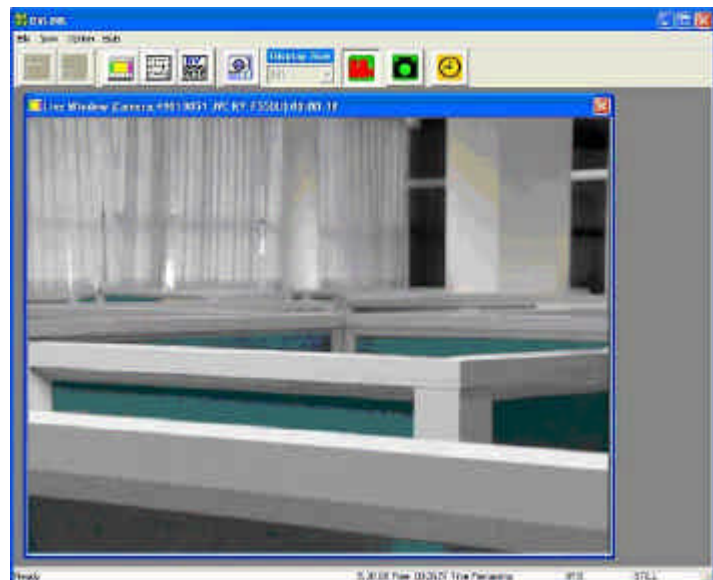

DV-LINK download site(under construction):

<http://www.victor.co.jp/english/pro/imagecamera/support.html>

DV-LINK for KY-F550

Video viewer mode

This mode provides all functions of DV-LINK (KY-F550 camera control, live image displaying, live image recording, snapshot and playback of the files.)

[NOTE]

- One KY-F550 camera can be connected.
- One DVR such as BR-DV3000/6000 or BD-X200 can be connected.
- Use a camera or a DVR by one format, NTSC only or PAL only.

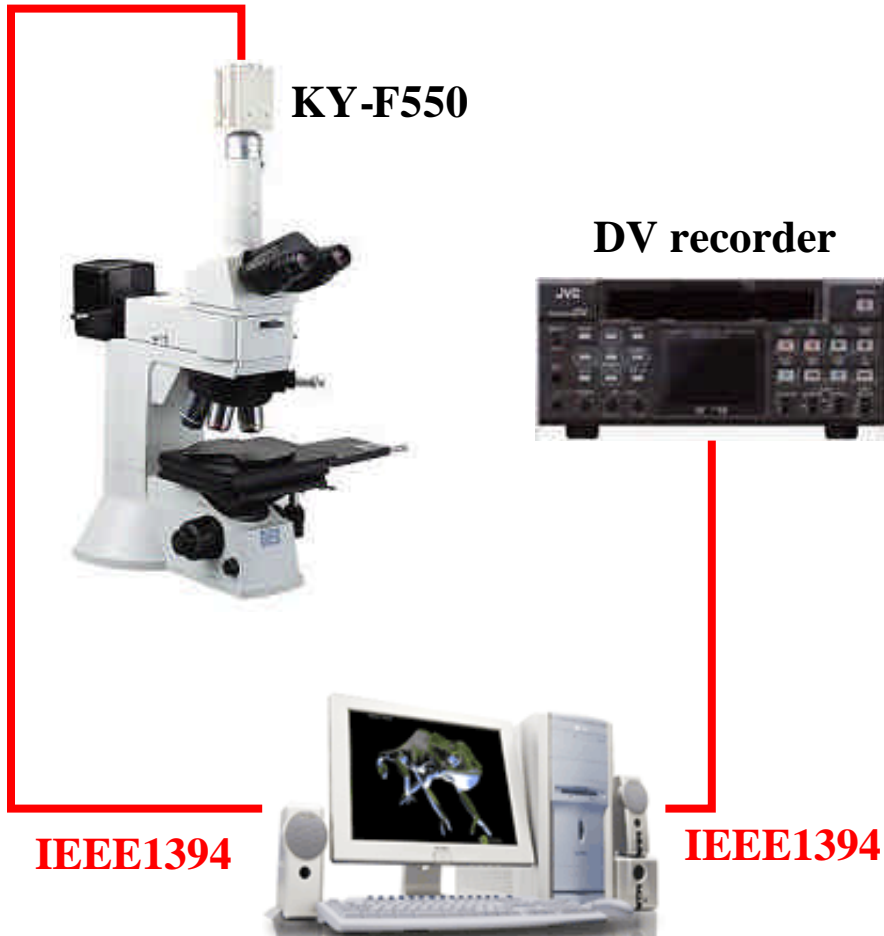

PC with IEEE1394
interface/driver and
DV-LINK

DV-LINK for KY-F550



IEEE1394

**PC with IEEE1394
interface/driver and
DV-LINK**

Camera control mode

This mode provides Camera control only. Use this mode when you have a monitor other than the PC running DV-LINK. This mode does not provide the function of image displaying, Snapshot, nor Recording. Operations at the Camera control window are the same as that of Camera control window of Video viewer mode.

[NOTE]

- This mode is to control a KY-F550 remotely via IEEE 1394. Displaying the image from the KY-F550, snapshot or operating a DVR is not allowed.
- During this mode, connect the video signal from KY-F550 to a DVR or a monitor by analog signal transmission. The video signal from KY-F550 should not be connected with a DVR via IEEE 1394.

SDK documentation for KY-F550

The SDK(Software Developers' Kit) is available for the developers who will integrate KY-F550 into their original system.

The sample application is also provided with this SDK.

SDK user will be not end users of KY-F550 but the developers or the system integrators who are selling the system with KY-F550.

The users of the sample application will be the same. Therefore, the purpose of the sample application is to show the example of application of the SDK usage. The priority of design is how easy to read source code rather than how easy to operate application.

The SDK for KY-F550 consists of “Kyf550Ctrl” component and “KyAviViewer” component and the sample application will be prepared for every component.

DV-LINK for KY-F550



Recommended PC performance of using the graphic card

CPU: Pentium IV 2.4GHz or more

Memory: 256Mbyte or more

**HDD:IDE 7200rpm or more
(RAID system is recommended)**

OS: Windows 2000/XP

Direct X:Version 9.0 or more

Software capacity for installation

Windows 2000:9.5M byte

Windows XP:5.5M byte

Recommended graphic cards

**NVIDIA: GeForce4MX, GeForceFX chip
mounted AGP graphic card**

(GeForce4MX420, GeForce FX5700)

ATI: Radeon 9600SE and 9800

Note:IEEE1394 Driver for DV-LINK should be exclusive in one PC.

Removable IR Cut Filter



IR Cut Filter

In case of 1CCD camera, light will be separated to RGB signals by on-chip filter on the CCD. One pixel consists of R x 1, B x 1, G x 2.

Therefore, this filter cannot be removed and the sensitivity of R channel is one fourth.

In case of 3CCD, light will be separated to RGB signals by prism and the CCD consists of monochrome. In order to cut IR (Infra Red) light, the filter is implemented before the prism. This is so-called “IR cut filter”. This “IR cut filter” on the KY-F550 can be removed and changed to the dummy filter consisting of transparent glass. As a result, the sensitivity at the range of IR will be dramatically increased. This picture is monochrome.

Removable IR Cut Filter

The IR cut filter is built in the lens in some optical equipments and switched. Therefore, color picture acquisition or high sensitive monochrome acquisition can be possible with the KY-F550 with the dummy filter consisting of transparent glass.

Parts number of dummy transparent glass for the KY-F550 is as follows,
 SC45530-003 (NTSC) Quartz Filter
 SC45530-013 (PAL) Quartz Filter

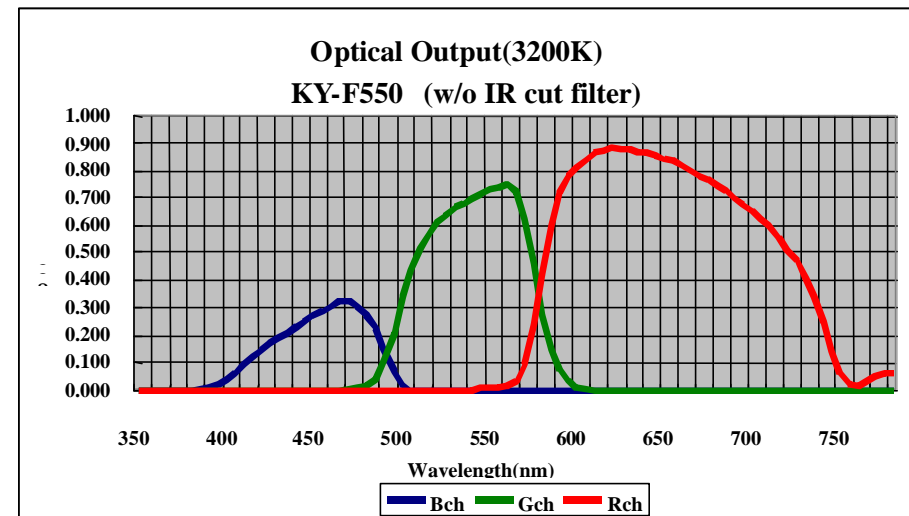
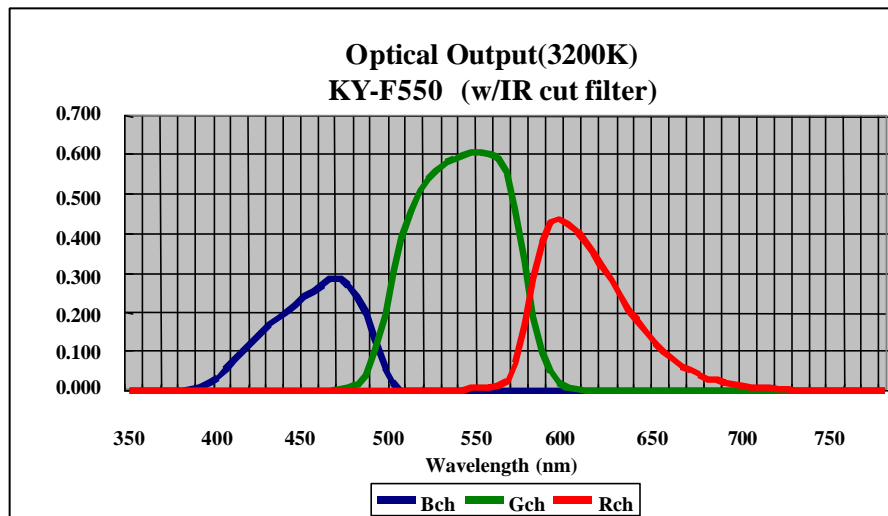

KY-F550 Auto Shading Compensation System

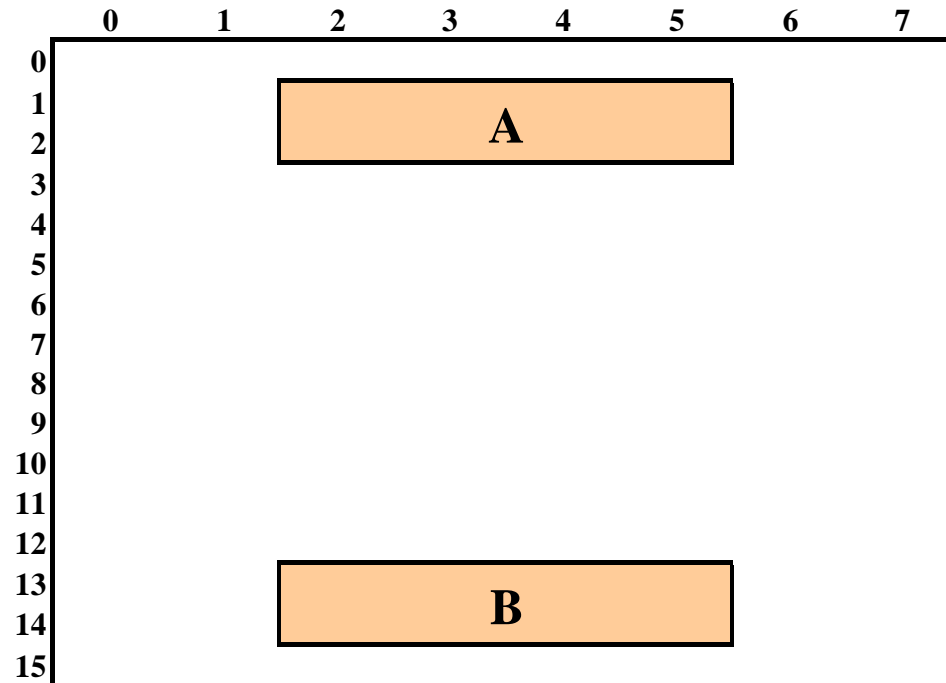

Auto shading compensation system is to compensate the white shading near the border of two pictures occurred by interference automatically. This system works to adjust the parameter of shading automatically to equalize the APL of area "A" and area "B" in each RGB channels.

A<B:To increase parameter

A>B:To decrease parameter

A=B:Not to change parameter(based on the same judgment system with AW)

After finishing operation, the message will appear on screen.

OK:Completed

Low light/Over light:Same condition with AW detection

Object:When the deviation between max value and minimum value of APL of each block in each channel of each A and B area is more than 5%. Or, when it cannot be detected even if parameter was set to maximum value or minimum value.

KY-F550 Random Trigger System

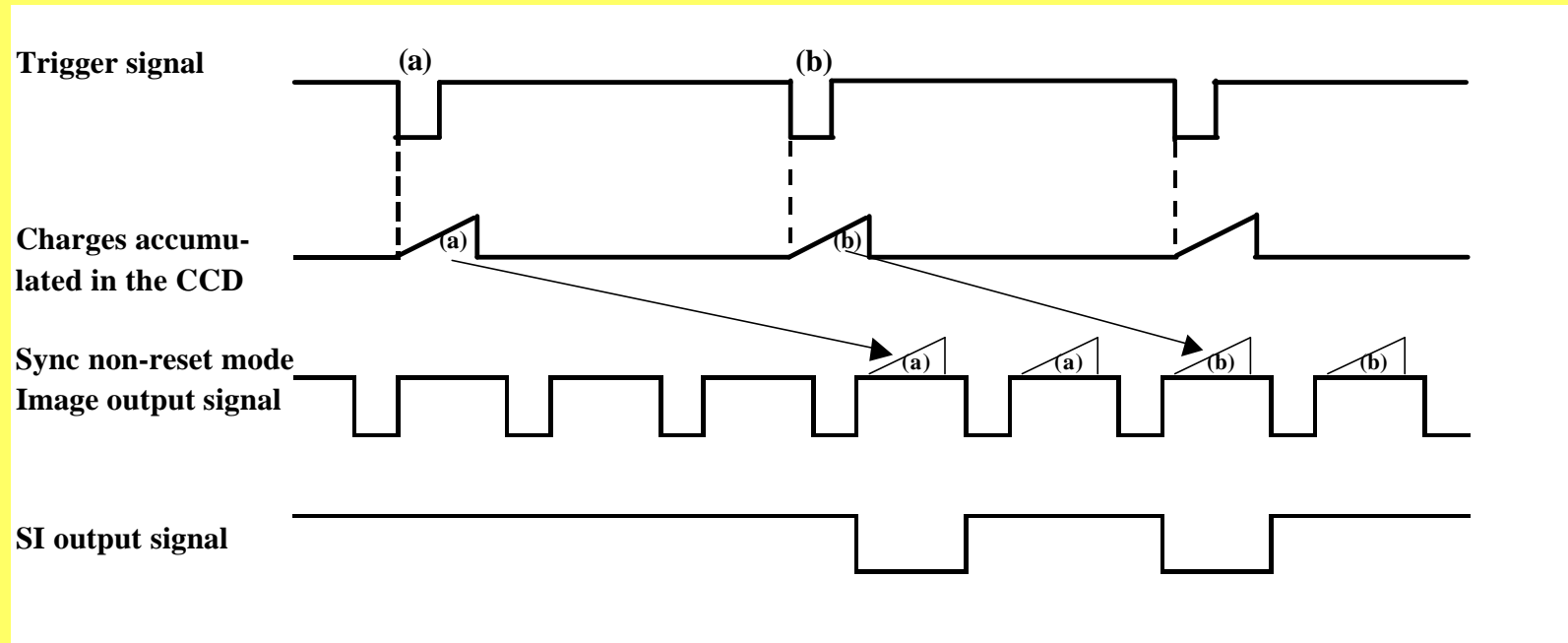

For verifying the image of an object detected.

If the trigger signal for the object detected is input, charges will be output following the next SYNC signal while simultaneously, the SI signal will be output as well, hence allowing the images to be stored in the memory.

The method of SYNC non-reset mode allows camera timing to be output irrespective of trigger input signal.

KY-F550 Slow Shutter System

*Slow Shutter 3 FRM setting

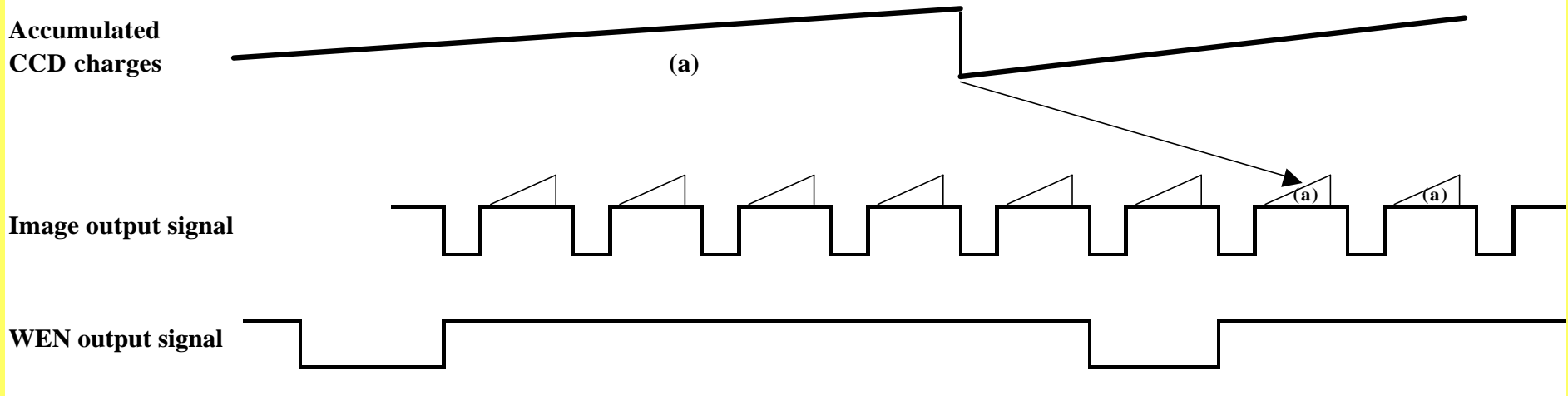

To brighten the images taken in dark places etc.

This function is not achieved through the method of increasing gain electronically. It is accomplished by accumulating charges stored in the CCD imaging device. In addition, by lengthening the duration for accumulating charges, more charges could be stored in the CCD and hence allowing high sensitivity images taken under low light condition. The maximum accumulation timing is up till 240(NTSC)/200(PAL) frames.(approx 8 sec)

Note:Please use the manual iris mode. Noise may increase when the number of frames increases, as such, set to an appropriate value.

KY-F550 Sample Application(Medical Image Analysis)

Market/Application Medical Image Analysis in Laboratory, University, etc.

Video Viewer Mode

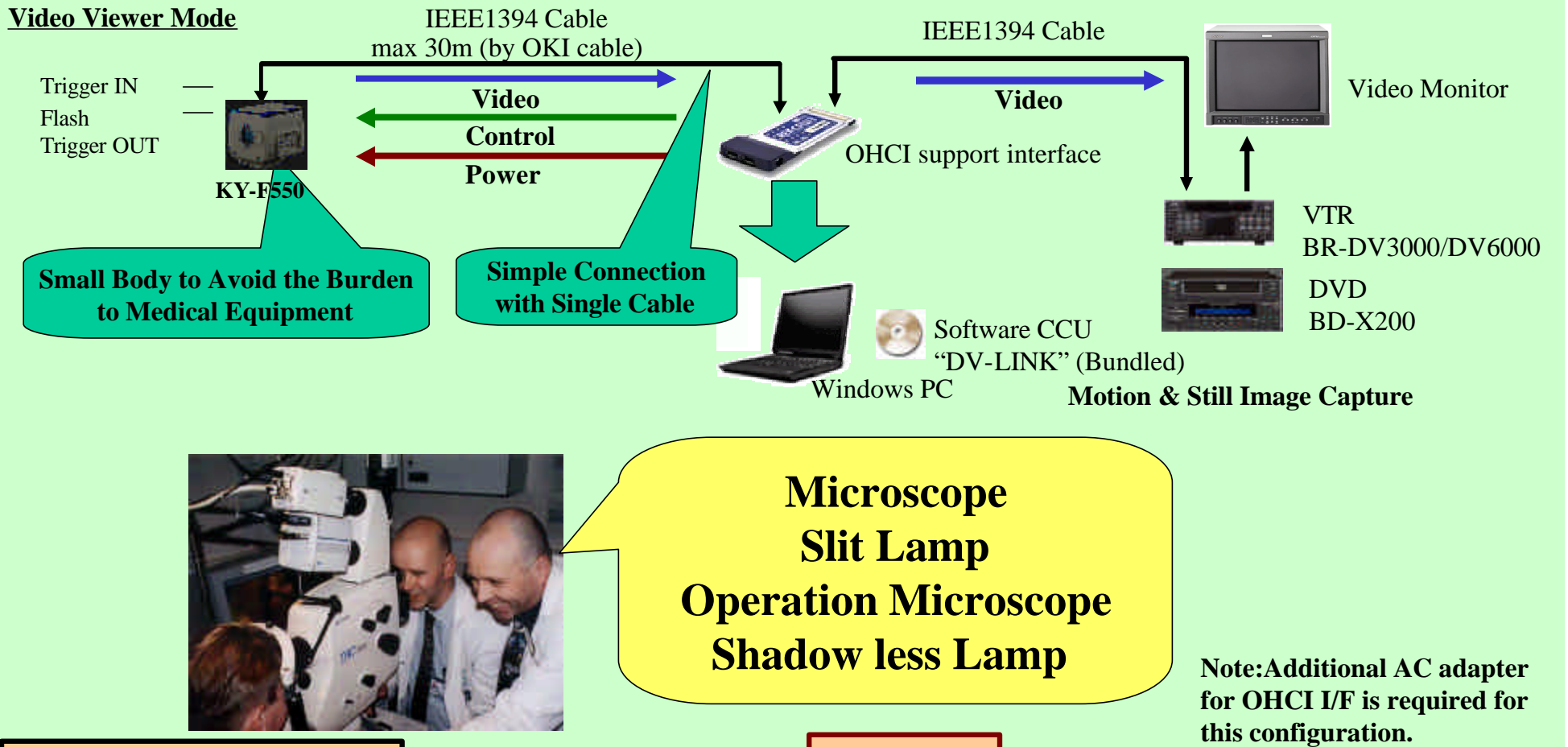

Customers' Demand

- Smart Cable Wiring with Camera
- Smart (Small Size) Body
- Simple Capturing into PC

Solution

Single cable connection available between camera and PC by DV output and power supply through IEEE1394 cable

KY-F550 Comparison

Manufacturer	JVC	JVC	Panasonic	SONY	HITACHI
Model Name	KY-F550	KY-F55B	AW-E300A	DXC-390	HV-D30
Dimensions (W x H x D)	70×64×80mm	70×64×120mm	84×77×145mm	56×50×128mm	65×65×80mm
Weight	380g	490g	700g	370g	400g
Image device	1/3inch 3CCD	1/3inch 3CCD	1/3inch 3CCD	1/3inch 3CCD	1/3inch 3CCD
Effective pixels	380,000(NTSC) 440,000(PAL)	380,000(NTSC) 440,000(PAL)	380,000(NTSC) 440,000(PAL)	380,000(NTSC) 440,000(PAL)	380,000(NTSC) 440,000(PAL)
Color Separation	Trichromatic prism	Trichromatic prism	Trichromatic prism	Trichromatic prism	Trichromatic prism
IR cut filter	Removable	Fixed	Fixed	Fixed	Fixed
Lens mount	C-mount	C-mount	C-mount	C-mount	C-mount
Sensitivity	F11/ 2000lx	F5.6/ 2000lx	F8/ 2000lx	F8/ 2000lx	F9.5/ 2000lx
Min. Illumination	F1.4/ 1lx	Not disclosed	F1.4/ 1.5lx	F2.0/ 4lx	F2.2/ 1.8lx
Horizontal Resolution	800 TVL	750 TVL	850 TVL	800 TVL	800 TVL
S/N ratio(NTSC/PAL)	62/60dB	60/58dB	63/61dB(DNR ON)	62/60dB	63/61dB(DNR ON)
Quantisation	12bit	Analog	10bit	10bit	12bit
Automatic Level Control	Yes	Yes	Yes	Yes	Yes
Automatic Shutter Adjustment (EEI)	Yes	Yes	Yes	Yes	Yes
White Balance	Yes	Yes	Yes	Yes	Yes
Black Balance	Yes	Yes	Yes	Yes	Yes
Dynamic Shading	Auto(Vertical Only)/Manual	Manual (Vertical Only)	Vertical Only	Vertical Only	Auto(Color or two dimensional luminance)/Manual
Lens control	Yes	Yes	Yes	Yes	Yes
Random Trigger	Sync Reset Non-reset	Sync Reset Non-reset	No	Sync reset	Sync reset
Sync input	No	Yes	Yes	Yes	Yes
Composite output	Yes	Yes	Yes	Yes	Yes
Y/C output	Yes	Yes	Yes	Yes	Yes
RGB output	Yes	Yes	option	Yes	Yes
Component output	No	No	option	No	Yes
DV output	Yes	No	option	No	No
Extender board slot	No	No	Yes	No	No
Power supply	DC Power Terminal IEEE1394	DC Power Terminal	DC Power Terminal	DC Power Terminal	DC Power Terminal

END

JVC

Free Manuals Download Website

<http://myh66.com>

<http://usermanuals.us>

<http://www.somanuals.com>

<http://www.4manuals.cc>

<http://www.manual-lib.com>

<http://www.404manual.com>

<http://www.luxmanual.com>

<http://aubethermostatmanual.com>

Golf course search by state

<http://golfingnear.com>

Email search by domain

<http://emailbydomain.com>

Auto manuals search

<http://auto.somanuals.com>

TV manuals search

<http://tv.somanuals.com>