

# JVC



## DVD AUDIO/VIDEO PLAYER

# XV-FA900BK/XV-FA902SL

Introduction	2
Getting started	6
Basic operations	14
Advanced operations	29
MP3 disc playback	51
JPEG disc playback	55
Changing the initial settings	60
Additional information	73



## INSTRUCTIONS

**For Customer Use:**

Enter below the Model No. and Serial No. which are located on the rear, bottom or side of the cabinet. Retain this information for future reference.

Model No. \_\_\_\_\_

Serial No \_\_\_\_\_

LET0220-001A

[J]

# Warnings, Cautions and Others

## Mises en garde, précautions et indications diverses



The lightning flash with arrowhead symbol, within an equilateral triangle is intended to alert the user to the presence of uninsulated "dangerous voltage" within the product's enclosure that may be of sufficient magnitude to constitute a risk of electric shock to persons.



The exclamation point within an equilateral triangle is intended to alert the user to the presence of important operating and maintenance (servicing) instructions in the literature accompanying the appliance.

### For U.S.A.

This equipment has been tested and found to comply with the limits for a Class B digital device, pursuant to part 15 of the FCC Rules. These limits are designed to provide reasonable protection against harmful interference in a residential installation.

This equipment generates, uses and can radiate radio frequency energy and, if not installed and used in accordance with the instructions, may cause harmful interference to radio communications. However, there is no guarantee that interference will not occur in a particular installation. If this equipment does cause harmful interference to radio or television reception, which can be determined by turning the equipment off and on, the user is encouraged to try to correct the interference by one or more of the following measures:

Reorient or relocate the receiving antenna.

Increase the separation between the equipment and receiver.

Connect the equipment into an outlet on a circuit different from that to which the receiver is connected.

Consult the dealer or an experienced radio/TV technician for help.

**WARNING: TO REDUCE THE RISK OF FIRE OR ELECTRIC SHOCK, DO NOT EXPOSE THIS APPLIANCE TO RAIN OR MOISTURE.**

### For Canada/pour le Canada

**CAUTION:** TO PREVENT ELECTRIC SHOCK, MATCH WIDE BLADE OF PLUG TO WIDE SLOT, FULLY INSERT

**ATTENTION:** POUR EVITER LES CHOCS ELECTRIQUES, INTRODUIRE LA LAME LA PLUS LARGE DE LA FICHE DANS LA BORNE CORRESPONDANTE DE LA PRISE ET POUSSER JUSQU'AU FOND

### For Canada/pour le Canada

THIS DIGITAL APPARATUS DOES NOT EXCEED THE CLASS B LIMITS FOR RADIO NOISE EMISSIONS FROM DIGITAL APPARATUS AS SET OUT IN THE INTERFERENCE-CAUSING EQUIPMENT STANDARD ENTITLED "DIGITAL APPARATUS", ICES-003 OF THE DEPARTMENT OF COMMUNICATIONS. CET APPAREIL NUMERIQUE RESPECTE LES LIMITES DE BRUITS RADIOELECTRIQUES APPLICABLES AUX APPAREILS NUMERIQUES DE CLASSE B PRESCRITES DANS LA NORME SUR LE MATERIEL BROUILLEUR: "APPAREILS NUMERIQUES", NMB-003 EDICTEE PAR LE MINISTRE DES COMMUNICATIONS.

### CAUTION

To reduce the risk of electrical shocks, fire, etc.:

1. Do not remove screws, covers or cabinet.
2. Do not expose this appliance to rain or moisture.

### ATTENTION

Afin d'éviter tout risque d'électrocution, d'incendie, etc.:

1. Ne pas enlever les vis ni les panneaux et ne pas ouvrir le coffret de l'appareil.
2. Ne pas exposer l'appareil à la pluie ni à l'humidité.



### Caution — STANDBY/ON button!

Disconnect the mains plug to shut the power off completely (the STANDBY/ON lamp goes off). The STANDBY/ON  button in any position does not disconnect the mains line.

- When the unit is on standby, the STANDBY/ON lamp lights red.
- When the unit is turned on, the STANDBY/ON lamp lights green.

The power can be remote controlled.

### Attention — Commutateur STANDBY/ON !

Déconnectez la prise d'alimentation secteur pour mettre l'appareil complètement hors tension (le témoin STANDBY/ON  s'éteint). L'interrupteur STANDBY/ON  , sur n'importe quelle position, ne peut pas déconnecter l'appareil du secteur.

- Quand l'appareil est en mode de veille, le témoin STANDBY/ON est allumé en rouge.
- Quand l'appareil est sous tension, le témoin STANDBY/ON est allumé en vert.

L'alimentation peut être télécommandée.

### IMPORTANT FOR LASER PRODUCTS IMPORTANT POUR LES PRODUITS LASER

1. CLASS 1 LASER PRODUCT
  2. **DANGER:** Visible laser radiation when open and interlock failed or defeated. Avoid direct exposure to beam.
  3. **CAUTION:** Do not open the top cover. There are no user service-able parts inside the Unit; leave all servicing to qualified service personnel.
1. PRODUIT LASER CLASSE 1
  2. **ATTENTION:** Radiation laser visible quand l'appareil est ouvert ou que le verrouillage est en panne ou désactivé. Eviter une exposition directe au rayon.
  3. **ATTENTION:** Ne pas ouvrir le couvercle du dessus. Il n'y a aucune pièce utilisable à l'intérieur. Laisser à un personnel qualifié le soin de réparer votre appareil.

### CAUTION

- Do not block the ventilation openings or holes. (If the ventilation openings or holes are blocked by a newspaper or cloth, etc., the heat may not be able to get out.)
- Do not place any naked flame sources, such as lighted candles, on the apparatus.
- When discarding batteries, environmental problems must be considered and local rules or laws governing the disposal of these batteries must be followed strictly.
- Do not expose this apparatus to rain, moisture, dripping or splashing and that no objects filled with liquids, such as vases, shall be placed on the apparatus.

### ATTENTION

- Ne bloquez pas les orifices ou les trous de ventilation. (Si les orifices ou les trous de ventilation sont bloqués par un journal un tissu, etc., la chaleur peut ne pas être évacuée correctement de l'appareil.)
- Ne placez aucune source de flamme nue, telle qu'une bougie, sur l'appareil.
- Lors de la mise au rebut des piles, veuillez prendre en considération les problèmes de l'environnement et suivre strictement les règles et les lois locales sur la mise au rebut des piles.
- N'exposez pas cet appareil à la pluie, à l'humidité, à un égouttement ou à des éclaboussures et ne placez pas des objets remplis de liquide, tels qu'un vase, sur l'appareil.

# Table of Contents

<b>Introduction</b> .....	Page 2
<b>Supplied accessories</b> .....	2
<b>Notes on handling</b> .....	3
Important cautions.....	3
Safety precautions.....	3
<b>About discs</b> .....	4
Playable disc types.....	4
Non-playable discs.....	4
Audio formats.....	4
Disc structure.....	5
Video CDs and SVCDs with Playback Control function.....	5
Care and handling of discs.....	5
<b>Getting started</b> .....	Page 6
<b>Connections</b> .....	6
Before making any connections.....	6
To connect to a TV.....	6
To connect to a stereo audio amplifier/receiver.....	9
To connect to an amplifier/receiver equipped with 5.1-channel inputs.....	9
To connect to a digital audio device.....	10
To connect the power cord.....	11
<b>Using the remote control unit</b> .....	12
To install batteries in the remote control unit.....	12
Remote sensor.....	12
To use the remote control unit for TV operation.....	13
To control the volume of a JVC's amplifier or receiver.....	13
<b>Basic operations</b> .....	Page 14
<b>Before operation</b> .....	14
Turning on/off the unit.....	14
The initial setup before using the unit.....	15
<b>Basic playback</b> .....	17
Inserting and removing discs.....	17
To start playback.....	19
To stop playback completely.....	20
To stop playback temporarily.....	20
To change discs during playback [EXCHANGE].....	20
To move back the playback position while DVD VIDEO playback [One touch replay function].....	21
<b>Resuming playback</b> .....	22
To memorize the interrupted position.....	22
To resume playback.....	23
<b>To locate the beginning of the scene or song</b> .....	24
To locate a desired selection using I◀◀ or ▶▶.....	24
To locate a desired selection using the numeric buttons.....	25
<b>Variable speed playback</b> .....	26
To advance or reverse playback rapidly while monitoring.....	26
To advance a still picture frame-by-frame.....	26
To play back in slow-motion.....	26
<b>Other convenient functions</b> .....	27
To check the playback status.....	27
To change the brightness of the display window.....	28
<b>Advanced operations</b> .....	Page 29
<b>Playing from a specific position on a disc</b> .....	30
To locate a desired scene from the DVD menu.....	30
To locate a desired scene from the menu of the SVCD/Video CD with PBC.....	30
To specify a desired title/group.....	31
To locate a desired position in the current title, group or track [Time search].....	31
To locate a desired scene from the display [DIGEST].....	32
To select a still picture on a DVD AUDIO disc [PAGE].....	33
To play back a bonus group of a DVD AUDIO disc.....	34
<b>Changing the playback order</b> .....	35
To play back in the desired order [Program playback].....	35
To play back in random order [Random playback].....	36
<b>Repeat playback</b> .....	37
To repeat the current selection or all tracks [Repeat playback].....	37

To repeat a desired part [A-B repeat playback].....	38
<b>Changing the language, sound and scene angle</b> .....	39
To select the subtitle language [SUB TITLE].....	39
To change the audio language or sound [AUDIO].....	40
To select a scene angle of DVD VIDEO [ANGLE].....	41
<b>Special picture playback and picture/sound effect</b> .....	42
To display continuous still pictures [STROBE].....	42
To zoom in/out pictures [ZOOM].....	43
To adjust the picture character [VFP].....	43
To simulate surround sound [3D PHONIC].....	44
<b>Checking the sampling frequency and bit rate</b> .....	45
<b>Menu bar functions</b> .....	46
To bring up the menu bar.....	46
Basic operation procedure.....	46
Menu bar functions for DVD AUDIO.....	47
Menu bar functions for DVD VIDEO.....	48
Menu bar functions for SVCD/Video CD/Audio CD.....	49

<b>MP3 disc playback</b> .....	Page 51
<b>About MP3 disc</b> .....	51
<b>Operations</b> .....	51
Basic operations.....	51
Selecting the desired Group and Track.....	52
Direct selection.....	53
Repeat playback.....	53
Checking the sampling frequency and bit rate.....	54

<b>JPEG disc playback</b> .....	Page 55
<b>About JPEG disc</b> .....	55
<b>Basic operations</b> .....	56
To see a desired picture.....	56
To zoom in/out the picture [ZOOM].....	57
<b>To see pictures continuously [slide show mode]</b> .....	57
To play back pictures from the beginning of the disc.....	57
Selecting the start point of the slide show.....	58
Repeat function.....	59

<b>Changing the initial settings</b> .....	Page 60
<b>Selecting preferences</b> .....	60
About the Preference display.....	60
How to set preferences.....	60
LANGUAGE page.....	61
PICTURE page.....	63
AUDIO page.....	64
SPK.SETTING page.....	66
OTHERS page.....	67
<b>Making fine tuning for your speakers</b> .....	68
To set the speaker sizes.....	68
To set the delay time.....	68
To set the speaker level.....	69
<b>Limiting playback by children</b> .....	70
To set Parental Lock for the first time [PARENTAL LOCK].....	70
To change the settings [PARENTAL LOCK].....	71
To temporarily release the Parental Lock [PARENTAL LOCK].....	72

<b>Additional information</b> .....	Page 73
<b>Names of parts and controls</b> .....	73
Front panel.....	73
Display window.....	73
Rear panel.....	73
Remote control unit.....	74
<b>AV COMPU LINK remote control system</b> .....	75
Connection and setup.....	75
Operation.....	75
<b>Troubleshooting</b> .....	76
<b>Frequently Asked Questions</b> .....	78
<b>Specifications</b> .....	79
<b>Appendix A: Country/Area code list for Parental Lock</b> .....	80
<b>Appendix B: Glossary</b> .....	81
<b>Appendix C: Index</b> .....	83

## Supplied accessories

- Audio/video cable (Yellow/White/Red) (x 1)

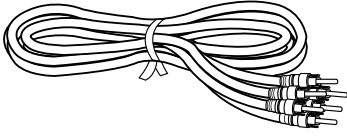

- R6P(SUM-3)/AA(15F) battery (x 2)

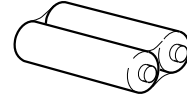

- Component video cable (Red/Green/Blue) (x 1)

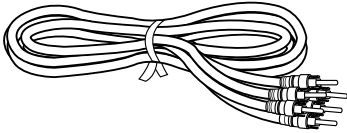

- AC power cord (x 1)

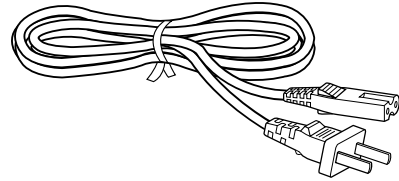

- Audio cable (White/Red) (x 2)

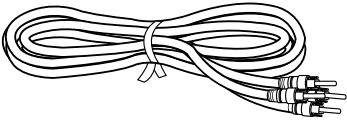

- Remote Control Unit (x 1)

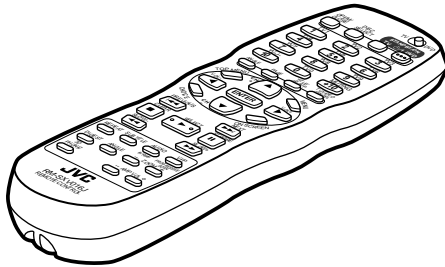

- AV compulink cable (x 1)

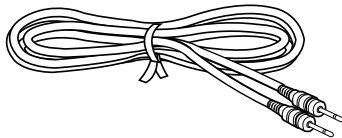

# Notes on handling

## Important cautions

### Installation of the unit

- Select a place which is level, dry and neither too hot nor too cold (between 5°C and 35°C, 41°F and 95°F).
- Leave sufficient distance between the unit and the TV.
- Do not use the unit in a place subject to vibrations.

### Power cord

- Do not handle the power cord with wet hands!
- A small amount of power (2.7 W) is always consumed while the power cord is connected to the wall outlet.
- When unplugging the unit from the wall outlet, always pull the plug, not the power cord.

### To prevent malfunction of the unit

- There are no user-serviceable parts inside. If anything goes wrong, unplug the power cord and consult your dealer.
- Do not insert any metallic object into the unit.
- Do not use any non-standard shape disc available on the market, because it may damage the unit.
- Do not use a disc with tape, seals, or paste on it, because damage to the unit may result.

### Note about copyright laws

- Please check the copyright laws in your country before recording from DVD AUDIO, DVD VIDEO, SVCD, Video CD, Audio CD, MP3 and JPEG discs. Recording of copyrighted material may infringe copyright laws.

### Note about the copyguard system

- The DVD VIDEO disc is protected by the copyguard system. When you connect the unit to your VCR (or integrated TV/Video system), the copyguard system activates and the picture may not be played back correctly.

## Safety precautions

### Avoid moisture, water and dust

Do not place the unit in moist or dusty places.

### Avoid high temperatures

Do not expose the unit to direct sunlight or place it nearby a heating device.

### When you are away

When you are away on travel or otherwise for an extended period of time, remove the plug from the wall outlet.

### Do not insert foreign objects into the unit

Do not insert wires, hairpins, coins, etc. into the unit.

### Do not block the vents

Blocking the vents may damage the unit.

### Care of the cabinet

When cleaning the unit, use a soft cloth and follow the relevant instructions on the use of chemically-coated cloths. Do not use benzene, thinner or other organic solvents and disinfectants. These may cause deformation or discoloring.

### If water gets inside the unit

Turn off the power and remove the plug from the wall outlet, then call the store where you made your purchase. Using the unit in this state may cause a fire or electrical shock.

This product incorporates copyright protection technology that is protected by method claims of certain U.S. patents and other intellectual property rights owned by Macrovision Corporation and other rights owners. Use of this copyright protection technology must be authorized by Macrovision Corporation, and is intended for home and other limited viewing uses only unless otherwise authorized by Macrovision Corporation. Reverse engineering or disassembly is prohibited.

Manufactured under license from Dolby Laboratories. "Dolby," "MLP Lossless" and the double-D symbol are trademarks of Dolby Laboratories.

Confidential unpublished works.

Copyright 1992-1998 Dolby Laboratories. All rights reserved.

Manufactured under license from Digital Theater Systems, Inc. US Pat. No. 5,451,942, 5,956,674, 5,974,380, 5,978,762, and other world-wide patents issued and pending. "DTS" and "DTS Digital Surround" are registered trademarks of Digital Theater Systems, Inc. Copyright 1996, 2000 Digital Theater Systems, Inc. All Rights Reserved.

## About discs

### Playable disc types

Playable disc types are as follows:

<b>DVD AUDIO</b> 	<b>DVD VIDEO</b> 	<b>SVCD</b> 
<b>Video CD</b> 		<b>Audio CD</b> 

The DVD Logo is a trademark.

- CD-R and CD-RW discs recorded with the SVCD, Video CD, Audio CD, MP3 or JPEG format can be played back, though some may not be played back because of the disc characteristics or recording conditions. Note that unfinalized discs cannot be played back.
- DVD-R discs recorded with the DVD VIDEO format can be played back, though some may not be played back because of the disc characteristics or recording conditions. Note that unfinalized disc cannot be played back.
- DVD VIDEO players and DVD VIDEO discs have their own Region Code numbers. This unit can play back only DVD VIDEO discs whose Region Code numbers include "1."

Examples of playable DVD VIDEO discs:



This unit accommodates the NTSC system, also can play back discs recorded with PAL system whose Region Code numbers include "1."

Note that the PAL video signal on disc is converted to an NTSC signal and output.

### Non-playable discs

Non-playable disc types are as follows:

DVD-ROM, DVD-RAM, DVD-RW, DVD+RW, CD-ROM, PHOTO CD, CD-EXTRA, CD-G, CD-TEXT, SACD, MIX-MODE CD

- Playing back discs listed as "Non-playable discs" above may generate noise and damage speakers.
- This unit can play back audio signals recorded in CD-G, CD-EXTRA, CD-TEXT and MIX-MODE CD discs.

### Audio formats

There are some audio formats recorded on discs as shown below.

- **Linear PCM**

Uncompressed digital audio, the same format used on CDs and most studio masters.

DVD AUDIO supports up to six channels at sample rates of 48/96/192 kHz (also 44.1/88.2/176.4 kHz) and sample sizes of 16/20/24 bits.

DVD VIDEO supports two channels at sampling rates of 48/96 kHz and quantization of 16/20/24 bits.

Audio CD/Video CD is limited to two channels, 44.1 kHz at 16 bits.

- **Dolby Digital**

A surround audio format configured with six channels. Because the "LFE (Low-Frequency Effect for sub-woofer, etc.)" channel, one of the six channels, is an auxiliary channel, this format is called "5.1-channel system."

Not all Dolby Digital discs contain six (5.1) channel information.

- **DTS (Digital Theater Systems)**

A surround audio format configured with six (5.1) channels, which is the same as Dolby Digital. Because the compression ratio is lower than Dolby Digital, it provides wider dynamic range and better separation. Not all DTS discs contain six (5.1) channel information.

- **MLP (Meridian Lossless Packing)**

A format for DVD AUDIO with the compression ratio of about 2:1 while allowing the PCM signal to be completely recreated by the MLP decoder (required in all DVD AUDIO players). It supports up to 192kHz/24-bit.

The associated indicator lights up in the display window when playing back a disc.

Indicator*	Audio format
LPCM	Linear PCM
DOLBY DIGITAL	Dolby Digital
DTS	DTS (Digital Theater Systems)

\* When playing back a DVD AUDIO disc recorded by MLP (Meridian Lossless Packing; a lossless audio compression system that can completely recreate the PCM signal), no indicator lights up in the display window.

Note that, with some formats and/or depending on the unit's "DIGITAL AUDIO OUTPUT" setting, digital audio signals are not always output from the unit's DIGITAL OUT jacks as are recorded on the disc. See "DIGITAL AUDIO OUTPUT" on page 64 for details.

## Disc structure

### (For DVD AUDIO)

A DVD AUDIO disc is comprised of "groups," and each group is comprised of "tracks." Some DVD AUDIO discs also contain a "bonus group" that can be played back by entering the "key number" (a kind of password). Usually the contents of a "bonus group" are not opened to the public. Note that most DVD AUDIO discs include other information in addition to audio, such as still pictures, movies and text.

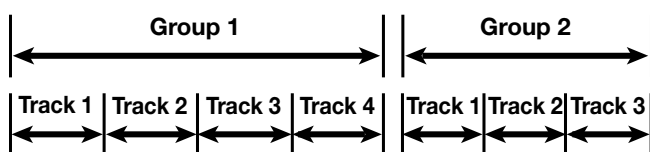

### (For DVD VIDEO)

A DVD VIDEO disc is comprised of "titles" and each title may be divided into some "chapters." For example, if a DVD VIDEO disc contains some movies, each movie may have its own title number, and each movie may be divided into some chapters. In a DVD VIDEO KARAOKE disc, each song usually has its own title number and does not have chapters.

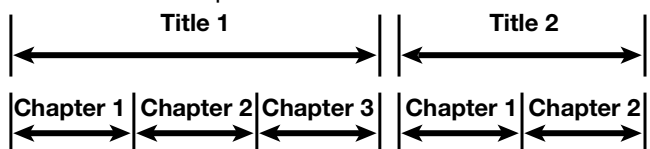

### (For SVCD/Video CD/Audio CD)

An SVCD, Video CD or Audio CD is simply comprised of "tracks."

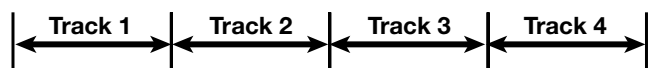

## Video CDs and SVCDs with Playback Control function

### What is Playback Control (PBC) function?

The Playback Control function, allows you to enjoy menu-driven operation and high-resolution still images which have a resolution four times greater than moving pictures.

- **High-resolution still image display**

You can display high-quality images four times clearer than moving pictures.

- **Menu-driven playback**

A selection menu is displayed when you start playing an SVCD and Video CD disc with the Playback Control feature. The selection menu shows a list of numbers for selection. Some discs may show moving pictures or a divided screen. You can interact with the screen using a menu display to select and play an entry.

See example illustration below about basic feature of menu-driven playback (for details about PBC, see also page 30).

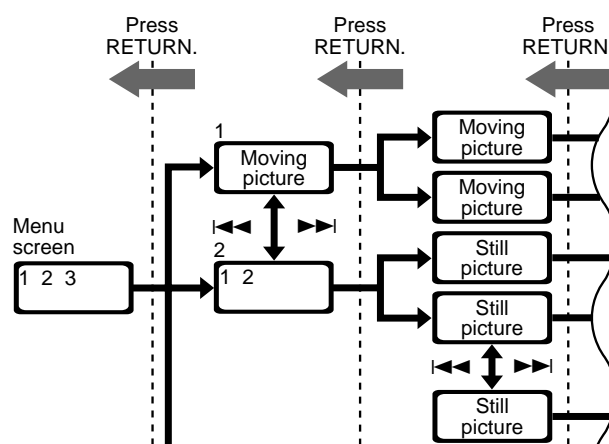

## Care and handling of discs

### How to handle discs

When handling a disc, do not touch the surface of the disc. Since discs are made of plastic, they are easily damaged. If a disc gets dirty, dusty, scratched or warped, the images and sound will not be picked up correctly, and such a disc may cause the player to malfunction.

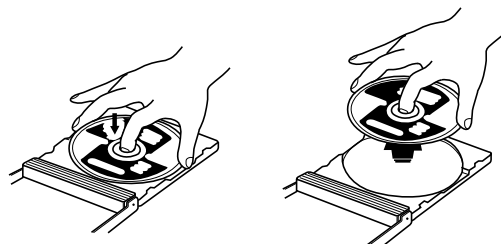

### Label side

Do not damage the label side, stick paper to or use any adhesive on its surface.

### Storage

Make sure that discs are kept in their cases. If discs are piled on top of one another without their protective cases, they can be damaged. Do not put discs in a location where they may be exposed to direct sunlight, or in a place where the humidity or temperature is high. Avoid leaving discs in your car!

### Maintenance of discs

If there are fingerprints or other dirt adhering to a disc, wipe with a soft dry cloth, moving from the center outwards.

If a disc is difficult to clean, wipe with a cloth moistened with water. Never use record cleaners, petrol, alcohol or any anti-static agents.



### CAUTION

Sometimes during play images may be garbled or noisy. This is sometimes due to the disc.

## Connections

\*Before using the unit, you have to connect the unit to a TV and/or amplifier.

### Before making any connections

- Do not connect the AC power cord until all other connections have been made.
- Connect VIDEO OUT of the unit directly to the video input of your TV. Connecting VIDEO OUT of the unit to a TV via a VCR may cause a monitor problem when playing back a copy-protected disc. You may also have a monitor problem when connecting the unit to an integrated TV/Video system.

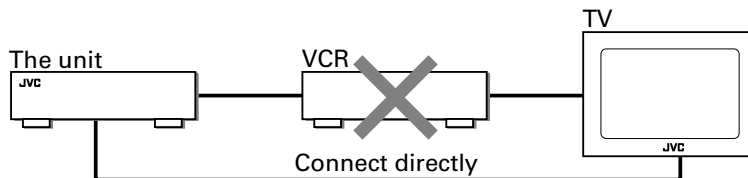

### NOTES

- In the following description, "TV" may be substituted with "monitor" or "projector."
- Terminal names used for other components may be different from those used in the following description.

### To connect to a TV

#### Connection to a conventional TV

You can enjoy playback by simply connecting the unit to a TV.

Connect the unit to a TV equipped with stereo audio input and video input jacks using the supplied audio/video cable.

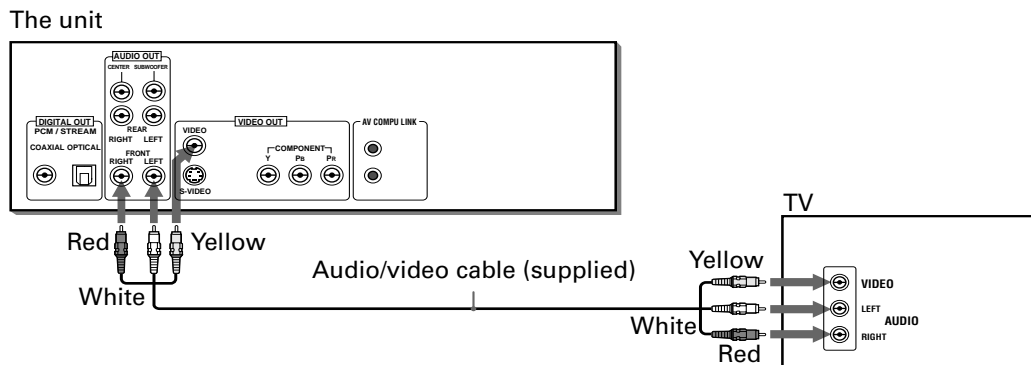

#### Connection to a TV equipped with an S-video jack

If your TV has an S-VIDEO input, you can get better picture quality by connecting it with the S-VIDEO output of the unit using the S-video cable instead of connecting the video input of the TV to the VIDEO jack of the unit.

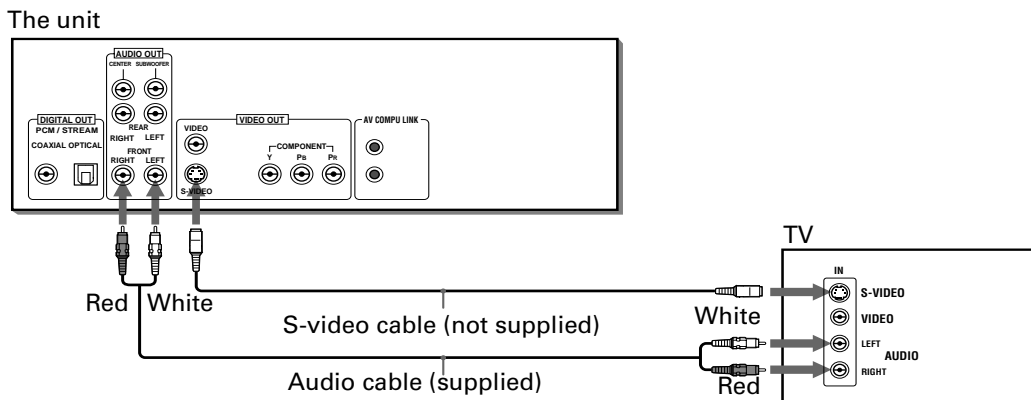

### NOTES

- When the scanning mode is set to the Progressive mode, you cannot see any picture using these connections above. To see the picture using the Progressive mode, see pages 7, 8.
- Set "ANALOG OUT" in the "AUDIO" preference display to "2-CH STEREO" (see page 65).



## Connection to a TV equipped with component jacks

You can enjoy high picture quality by connecting the unit's COMPONENT VIDEO OUT jacks to the COMPONENT VIDEO IN jacks of your TV with the video cables.

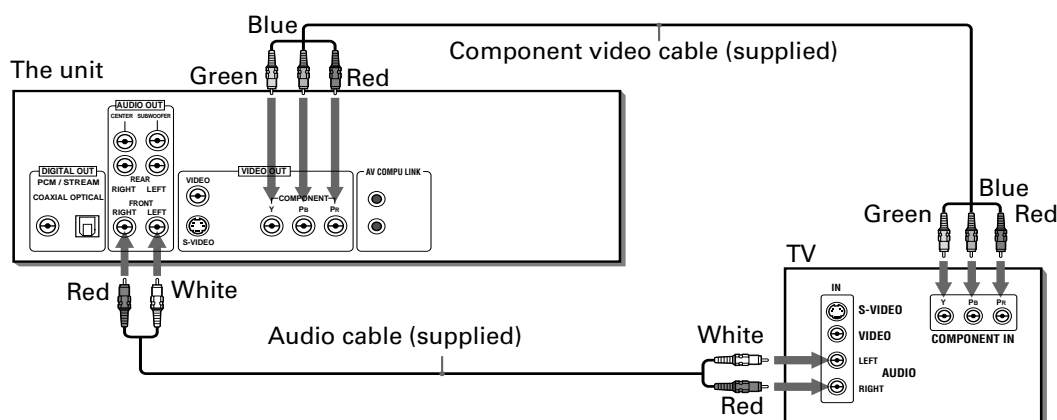

- Connect "Y" to "Y," "P<sub>B</sub>" to "P<sub>B</sub>" (C<sub>B</sub>), "P<sub>R</sub>" to "P<sub>R</sub>" (C<sub>R</sub>) correctly.

The unit supports the Progressive scanning system as well as the conventional Interlaced scanning system.

If your television or monitor equipped with component jacks support the progressive video input, you can enjoy a high quality picture by making the Progressive scanning mode active.

### NOTES

- When the scanning mode is set to the Progressive mode, the PROGRESSIVE indicator on the front panel is lit. The color of the indicator differs depending on the "PROGRESSIVE MODE" setting on the "PICTURE" preference display and the status of the unit (see pages 8 and 63).
- When connecting to a TV using the VIDEO or S-VIDEO jack, make sure that the PROGRESSIVE indicator on the front panel is not lit. If it is lit, the VIDEO and S-VIDEO outputs do not feed the correct signals. To turn off the PROGRESSIVE indicator, make the Progressive scanning mode inactive by following the procedure described on page 8.
- When the component video input jacks on the TV is of the BNC type, use an adapter to convert a pin jack to a BNC jack (optional).
- Set "ANALOG OUT" in the "AUDIO" preference display to "2-CH STEREO" (see page 65).
- If your TV has a monaural audio input instead of stereo, you need to use an optional audio cable which converts stereo audio output to monaural.
- To improve audio sound quality, connect the AUDIO OUT jacks to your separate audio equipment (see pages 9, 10).
- If your TV has an AV COMPU LINK terminal, you can use the AV COMPU LINK function. See "AV COMPU LINK remote control system" on page 75 for details.

### About SCANNING MODE

To display video on the television (monitor) screen, the conventional scanning method is called "Interlaced scanning." With this method, only half of the horizontal lines are displayed at a time. So two fields complete a single picture (frame); i.e., the first field, containing all the odd-numbered lines, is displayed followed by the second field, containing all the even-numbered lines.

On the other hand, the Progressive scanning system scans all horizontal lines at a time, so you can double the number of pictures compared with the interlaced scanning, resulting in flicker-free, high-density picture.

To enjoy the progressive scanned video, a monitor (or TV or projector) to be connected to the unit must have the Progressive inputs.

Depending on the material source format, DVD VIDEO discs can be classified into two types; film source and video source (note that some DVD VIDEO discs contain both film source and video source). Film sources are recorded as 24-frame-per-second information, while (NTSC) video sources are recorded as 30-frame-per-second (60-field-per-second interlaced) information.

When the unit plays back a film source material, uninterlaced progressive output signals are created using the original information. When a video source material is played back, the unit interleaves lines between the interlaced lines on each to create the interpolated picture and outputs as the progressive signal.

## To make the Progressive scanning mode selection active

The unit supports the Progressive scanning system as well as the conventional Interlaced scanning system. If your television or monitor supports the progressive video input, you can enjoy a high quality picture by making the Progressive scanning mode active.

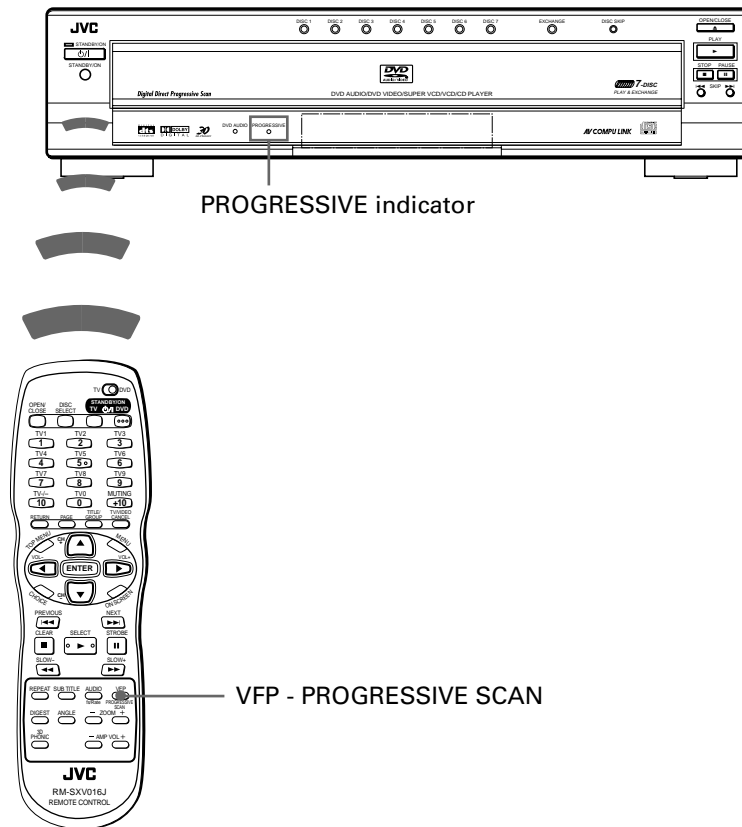

Press and hold down VFP - PROGRESSIVE SCAN for a few seconds.

The scanning mode switches between the Progressive scanning and Interlaced scanning modes.

- When the scanning mode is set to the Progressive mode, the PROGRESSIVE indicator on the front panel is lit. Depending on the "PROGRESSIVE MODE" setting on the "PICTURE" preference display and whether the current DVD VIDEO disc is film-source or video-source, the color of the indicator differs, as shown in the table below (see also pages 7 and 63).

Setting of PROGRESSIVE MODE	Source type of DVD VIDEO		Note
	Film Source	Video Source	
VIDEO	Red	Red	While stopped in the Progressive scanning mode, the PROGRESSIVE indicator is lit in red regardless of the "PROGRESSIVE MODE" selection.
FILM	Green	Green	
AUTO	Green	Red	

### NOTES

- There are some progressive TV and High-Definition TV sets that are not fully compatible with the unit, resulting in the unnatural picture when playing back a DVD VIDEO disc in the Progressive scanning mode. In such a case, use the Interlaced scanning mode. To check the compatibility of your TV set, contact your local JVC customer service center.
- All JVC progressive TV and High-Definition TV sets are fully compatible with the unit (Example : AV-61S902).

## To connect to a stereo audio amplifier/receiver

You can enjoy high-quality audio by connecting the unit's audio output to your amplifier or receiver. Connect the unit's AUDIO OUT (FRONT LEFT/FRONT RIGHT) jacks to any line-level inputs (such as AUX, DVD, CD, etc.) of an audio amplifier or receiver.

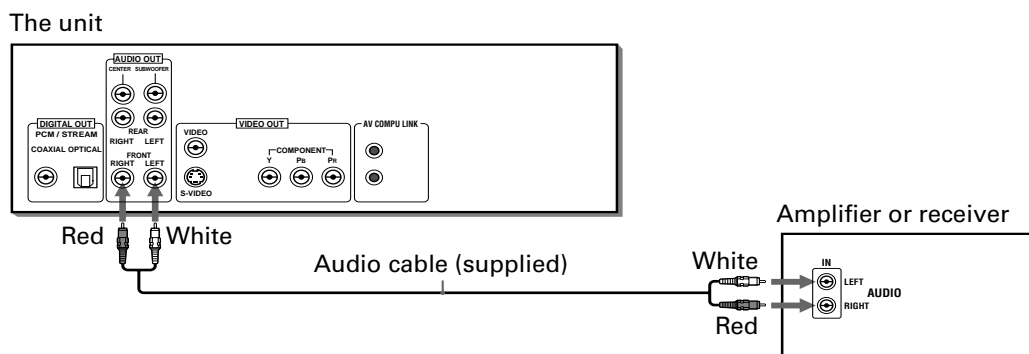

### NOTES

- When using the unit with a stereo amplifier or receiver, set "ANALOG OUT" in the "AUDIO" preference display to "2-CH STEREO" (see page 65).
- If your stereo amplifier or receiver has an AV COMPU LINK terminal, you can use the AV COMPU LINK function. See "AV COMPU LINK remote control system" on page 75 for details

## To connect to an amplifier/receiver equipped with 5.1-channel inputs

The unit supports the linear PCM multichannel format of DVD AUDIO and can feed multichannel audio output signals from the six analog AUDIO OUT jacks.

It is also equipped with the DTS and Dolby digital decoders. So you can enjoy any type of the high quality surround sounds by connecting the unit to an amplifier/receiver equipped with the 5.1-channel inputs.

Connect the unit's analog AUDIO OUT jacks to the analog 5.1-channel inputs of an amplifier or receiver using the supplied audio cables.

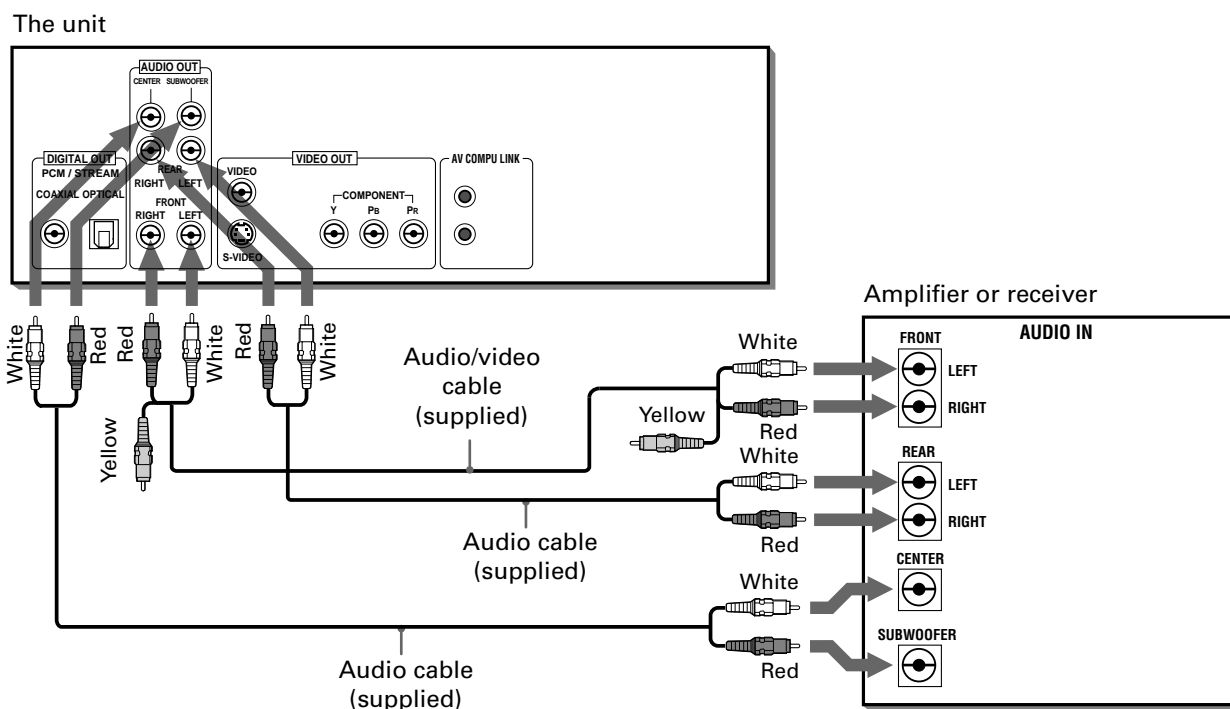

- Be sure to connect correctly between corresponding terminals. The order of the 5.1-channel terminals depend on units.

### NOTE

- When using the 5.1-channel outputs of the unit, set the "ANALOG OUT" in the "AUDIO" preference display to "MULTI CHANNEL" (see page 65). If you select "EXPERT" in the "SPK.SETTING" preference display, you can control the audio output balance of the speakers (see page 66).

## To connect to a digital audio device

You can enhance the sound quality by connecting either of the unit's DIGITAL OUT jacks to the digital input of an amplifier, etc. by using an optical or a coaxial digital cable (optional). The digital audio signal from a disc is directly transferred. If you connect the unit to a Dolby Digital or DTS decoder or an amplifier with a built-in decoder by using an optional digital cable, you can enjoy high-quality surround sound. For digital connection, connect the unit's DIGITAL OUT (OPTICAL or COAXIAL) to the digital input of digital audio device using an optical or a coaxial digital cable.

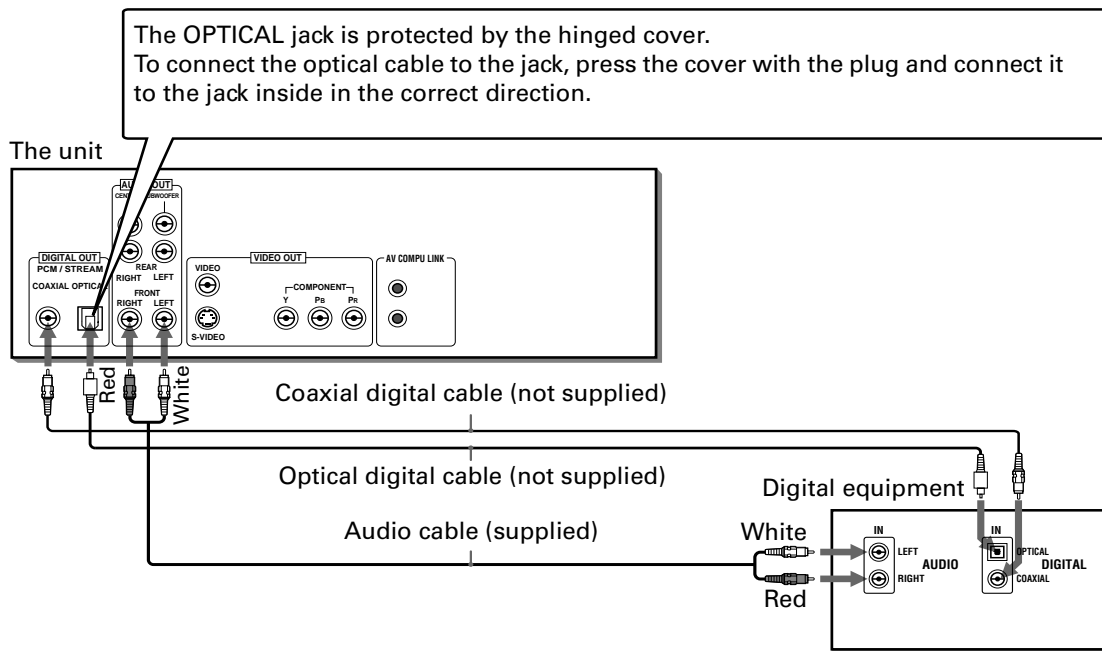

Note that the DIGITAL OUT jacks on the unit have been designed and equipped exclusively for enjoying the digital surround sound playback through the unit. It is not recommended to use the jacks for digital dubbing. When recording the sounds (DVD AUDIO, DVD VIDEO, SVCD, Video CD, or Audio CD) played back on the unit, record them through the analog jacks (in this case, set "ANALOG OUT" in the "AUDIO" preference display to "2-CH STEREO") (see page 65).

### NOTES

- When you connect the unit's DIGITAL OUT to a digital audio device, before using, set "DIGITAL AUDIO OUTPUT" in the "AUDIO" preference display correctly according to the connected audio device. If "DIGITAL AUDIO OUTPUT" is not set correctly, loud noise may be generated from speakers, causing damage to them. See "DIGITAL AUDIO OUTPUT" on page 64.
- When you connect the unit's DIGITAL OUT to a Dolby Digital or DTS decoder (or amplifier with a built-in decoder) to enjoy surround sound, the unit's "D. RANGE COMPRESSION" setting in the "AUDIO" preference display is invalid. Make appropriate surround audio settings on the decoder.
- If your digital audio device has an AV COMPU LINK terminal, you can use the AV COMPU LINK function. See "AV COMPU LINK remote control system" on page 75 for details.

## To connect the power cord

English

When all the audio/video connections have been made, insert the smaller plug of the supplied AC power cord to the unit's  $\sim$  AC IN connector, then insert the other end to the wall outlet. Make sure that plugs are inserted firmly. The STANDBY/ON indicator lights in red.

Note that the shape of the smaller plug of the AC power cord is not perfectly symmetrical as illustrated below.

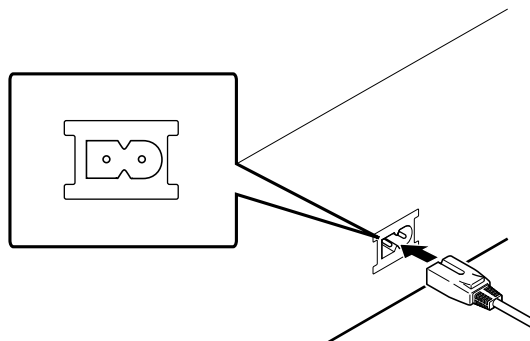

### Warning

- Disconnect the power cord if you are not going to use the unit for a long time.
- Disconnect the power cord before cleaning the unit.
- Disconnect the power cord before moving the unit.
- Do not connect or disconnect the power cord with wet hands.
- Do not pull the power cord when disconnecting it, as this may damage the cord and cause fire, electric shock, or other accidents.

### Caution

- Do not alter, twist or pull the power cord, or put anything heavy on it, which may cause fire, electric shock, or other accidents.
- To prevent any accidents or damage caused by an unsuitable AC power cord, only use the supplied power cord. If the cord is damaged, contact a dealer and get another power cord.

## Using the remote control unit

Using the remote control unit, you can operate not only all the functions of the unit but also basic functions of your TV and amplifier/receiver.

### To install batteries in the remote control unit

The battery compartment is located on the back of the remote control unit.

- 1 Press down on the point shown by the arrow at the top of the compartment cover, and pull up the cover to open the compartment.



- 2 Place the two supplied R6P (SUM-3)/AA(15F) batteries in the remote control unit according to the polarity markings (“+” and “-”) inside the compartment and on the batteries.

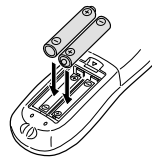

- 3 Place the cover over the compartment, and press down lightly.



The batteries will last about six months with normal use. If the functions of the remote control unit become erratic, replace the batteries. See below for more information.

### Precautions for the safe use of batteries

Observe the following precautions for the safe use of batteries. If they are used improperly their lives will be shortened, they may burst or their contents may leak.

#### Precaution

- Remove the batteries from the remote control unit if it is not going to be used for a long period of time.
- Remove dead batteries and dispose of them properly.
- Never leave dead batteries lying around, take them apart, mix them with other refuse, or throw them into an incinerator.
- Never touch liquid that has leaked out of a battery.
- Do not mix new and old batteries, or batteries of different types, when replacing them.

### Remote sensor

- Operate the remote control unit while pointing it toward the remote sensor on the unit.
- The remote control unit can be used within a range of about 5 meters from the remote sensor. If you operate the remote control unit from a diagonal position, controllable distance may be shorter.

#### Remote sensor

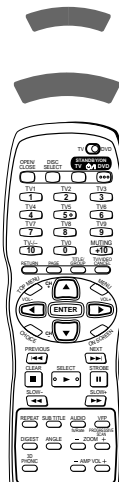
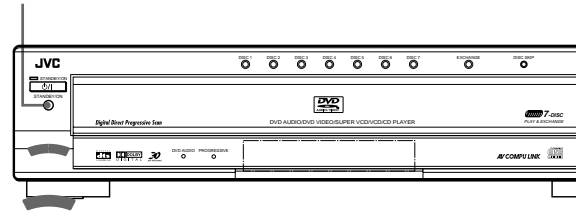

#### NOTE

- If the remote sensor on the unit is exposed to the sunshine or strong light, you may not be able to control the unit from the remote control unit.

## To use the remote control unit for TV operation

You can operate your TV from the remote control unit.

### Setting the remote control signal for operating your TV

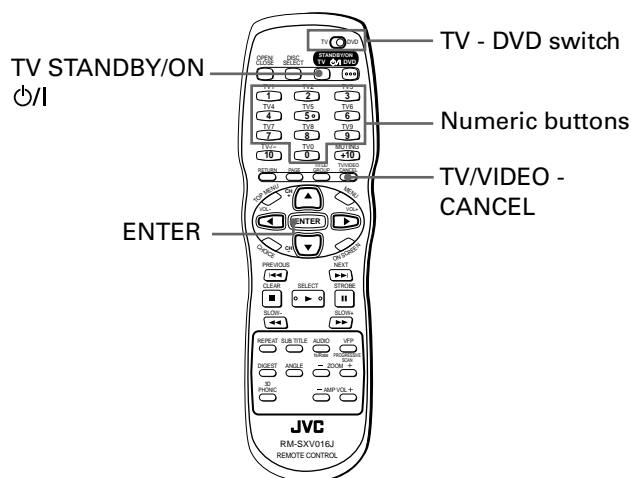

- 1 Set the TV - DVD switch to "TV."
- 2 Hold down TV/VIDEO - CANCEL until step 4 is done.
- 3 Enter the manufacturer code of your TV listed below by using the numeric buttons (0 to 9).

#### Example for a JVC TV:

To enter the manufacturer code "01": Press "0" then "1."

- 4 Press ENTER.

#### Manufacturer code list

Manufacturer	No.	Manufacturer	No.
AIWA	36	MIVAR	29
BEIJING	22	NEC	20
CCE	02	NOBLEX	22
CHANGHONG	34	NOKIA	31
DAEWOO	17, 37	PANASONIC	04, 11
FERGUSON	27	PEONY	34, 38, 39
FINLUX	30	PHILCO	10, 17, 21
FUNAI	32	PHILIPS	02
GRADIENTE	15, 20	RCA	05
GRUNDIG	19	SAMSUNG	12, 33, 34, 35
HITACHI	10		
ITT	28	SANYO	13, 16
JINXING	38	SEARS	13
JVC	01, 23, 24, 25	SHARP	06
		SONY	07
KONKA	40	TCL	41
LG (GOLDSTAR)	18	THOMSON	26
MAGNAVOX	02	TOSHIBA	08, 14
MITSUBISHI	03	ZENITH	09

- 5 Release TV/VIDEO - CANCEL.

- 6 Try to operate the TV by pressing TV STANDBY/ON  $\odot/\text{I}$ .

If your TV turns on or off, you have successfully set the control signal.

The following buttons can be used for operating the TV.

To use  $\blacktriangle/\blacktriangledown$  (CH+, CH-),  $\blacktriangleleft/\blacktriangleright$  (VOL-, VOL+), TV/VIDEO - CANCEL and numeric buttons for TV control, set the TV - DVD switch to "TV."

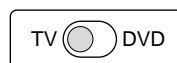

	<b>Turns the TV on or off.</b>
	<b>Switches the TV input mode between TV and VIDEO.</b>
	<b>Selects the TV channels directly.</b> * For some TVs, pressing "+10" functions as the "100+," while "10" functions as the ENTER button if your TV requires pressing the ENTER button after selecting a channel number.
	<b>Mutes the TV sound.</b>
	<b>Changes the TV channels.</b>
	<b>Adjusts the TV volume.</b>

#### NOTE

- If there is more than one code listed for the manufacturer code of your TV, try them one by one until you succeed.

## To control the volume of a JVC's amplifier or receiver

You can control the volume of a JVC's amplifier or receiver by using the AMP VOL +/- buttons on the remote control unit.

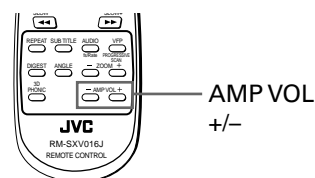

Pressing the + button raises the audio volume of the amplifier or receiver, while pressing the - button lowers the volume.

# Basic operations

In the following description, we assume that the buttons on the remote control unit are mainly used, however, you may use the corresponding buttons on the front panel if available.

## NOTE

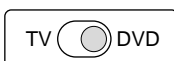

Make sure that the TV - DVD switch on the remote control unit is set to "DVD" when using the ▲/▼/◀/▶ and numeric buttons for controlling the unit.

## Before operation

### Turning on/off the unit

Press DVD STANDBY/ON  $\odot/\text{I}$  on the remote control unit or press STANDBY/ON  $\odot/\text{I}$  on the front panel.

When the unit turns on, the STANDBY/ON indicator on the front panel, which illuminates in red during standby, lights in green and each DISC indicator (1 to 7) shows the current status of whether a disc is set or not in the corresponding disc tray.

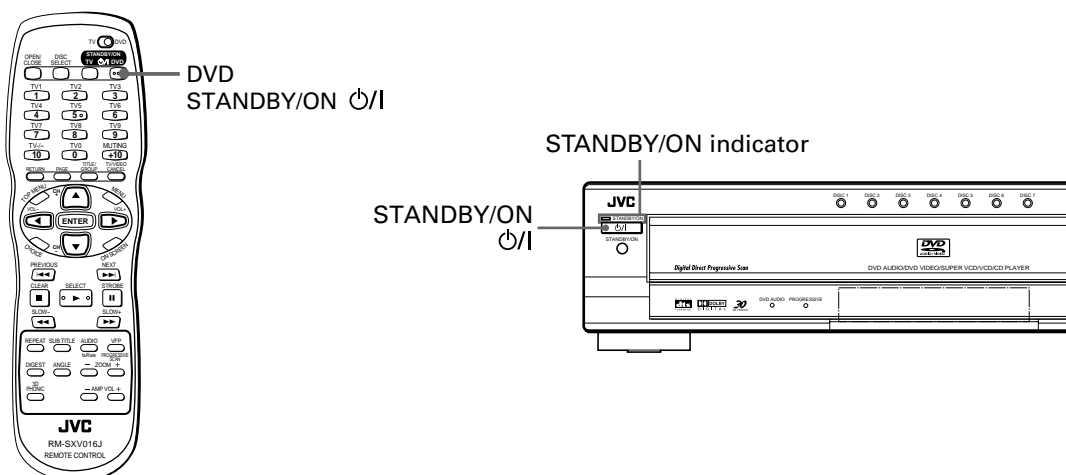

## Hints

- The first time you turn on the unit after connecting the power cord, the DISC 1 to 7 indicators are illuminated until the unit detects that no disc is set in the corresponding disc tray. Once detecting the status, the unit memorizes it unless you unplug the power cord, so the DISC 1 to 7 indicators show the status of corresponding disc trays correctly.
- You can turn on the unit by pressing the ▶ button. In this case, the behavior of the unit after pressing the ▶ button is the same as pressing this button while the power is on.
- When any disc is on the disc tray, you can turn on the unit using the DISC 1 to 7 buttons corresponding to the loaded disc number. The behavior of the unit after pressing these buttons is the same as pressing them while the power is on.
- You can turn on the unit by pressing the ▲ OPEN/CLOSE button on the front panel. In this case, the disc tray carousel opens.

The opening display shown right appears on the TV screen.

The following message may appear at the bottom of the opening display depending on the condition.

- NOW READING: The unit is reading the disc information.
- REGION CODE ERROR!:  
The region code of the DVD VIDEO disc does not match the unit. The disc cannot be played back.
- OPEN: The disc tray carousel is opening.
- CLOSE: The disc tray carousel is closing.
- NO DISC: No disc is loaded.
- RESUME STOP:  
The resume mode is set to "DISC RESUME."



Message area

## NOTE

- Even if you press DVD STANDBY/ON  $\odot/\text{I}$  on the remote control unit or STANDBY/ON  $\odot/\text{I}$  on the front panel to turn off the unit, the unit is not disconnected from the AC power source as long as it is connected to the wall outlet. This state is called the standby mode. In this state, the unit consumes a very small amount of power.



## The initial setup before using the unit

We recommend you to set the display language, TV monitor type, analog audio output and digital output before using the unit, depending on circumstances, by following the procedure below.  
See "Changing the initial settings" on and after page 60 for details about each setting item.

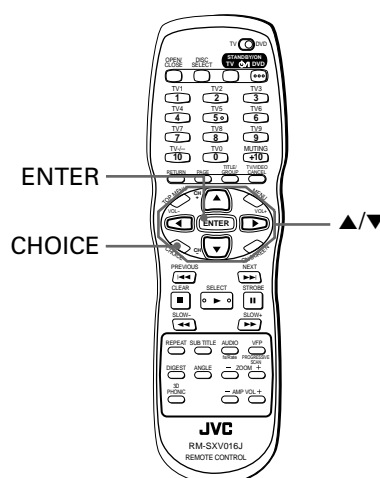

- 1 Press and hold down CHOICE for a few seconds to bring up the first page of the DVD PLAYER SET UP display.

The pull-down menu of the "ON SCREEN LANGUAGE" is already open.

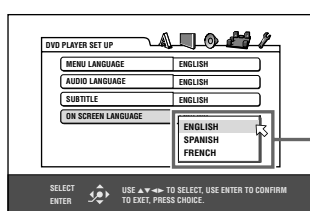

ON SCREEN LANGUAGE selection

- 2 Use ▲/▼ to select a desired language.

You can select the on-screen language for the preference displays, etc. from among English, Spanish and French.

- 3 Press ENTER.

The second page is shown, in which the pull-down menu of the "MONITOR TYPE" is already open.

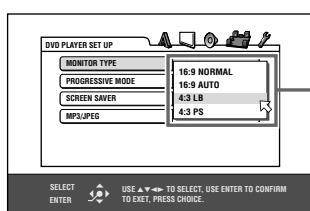

MONITOR TYPE selection

- 4 Use ▲/▼ to select a desired monitor type.

You can select the monitor type according to your TV.

- For the normal (conventional) TV, select "4:3 LB" or "4:3 PS."
- For the wide-screen TV, select "16:9 AUTO" or "16:9 NORMAL."

See page 63 for details about each mode.

- 5 Press ENTER.

The third (final) page is shown, in which the pull-down menu of the "ANALOG OUT" is already open.

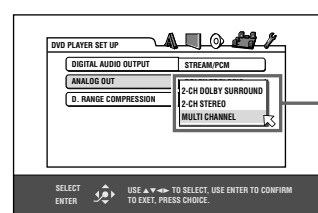

ANALOG OUT selection

- 6 Use ▲/▼ to select a desired analog output signal type.

You must set this item correctly when you play back a DVD VIDEO disc recorded with surround multichannel audio.

- When connecting with a surround decoder, select "2-CH DOLBY SURROUND."
- When connecting with a stereo amplifier/receiver or television set, select "2-CH STEREO."
- When connecting the unit's 5.1 channel audio outputs to an amplifier equipped with 5.1-channel input, select "MULTI CHANNEL."

See page 65 for details.

## 7 Press ENTER.

The pull-down menu of the "DIGITAL AUDIO OUTPUT" appears.

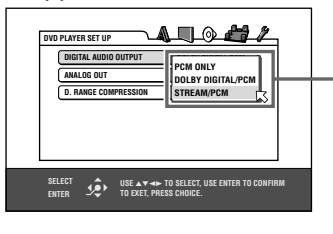

DIGITAL AUDIO OUTPUT selection

## 8 Use ▲/▼ to select a desired digital output signal type.

You must set this item correctly when you connect the unit to an external surround decoder or D/A convertor (including an amplifier/receiver with built-in surround decoder or D/A convertor). (If you do not connect the unit to such a device, you do not have to set this item.)

- When connecting with a Dolby Digital decoder, select "DOLBY DIGITAL/PCM."
- When connecting with a DTS or MPEG Multichannel decoder, select "STREAM/PCM."
- When connecting with other digital devices, select "PCM ONLY."

See page 64 for details.

## 9 Press ENTER.

The TV screen returns to show the opening display.

### NOTES

- This setting may not be necessary except when turning on the power after purchasing the unit.
- You can also set these items, as well as other preferences, by pressing CHOICE briefly to bring up the preference display. See "Changing the initial settings" on and after page 60 for details.

## Basic playback

This section describes basic operations for playback of DVD AUDIO, DVD VIDEO, SVCD, Video CD and Audio CD discs. For MP3 and JPEG disc playback, see the separate chapter on and after pages 51 and 55.

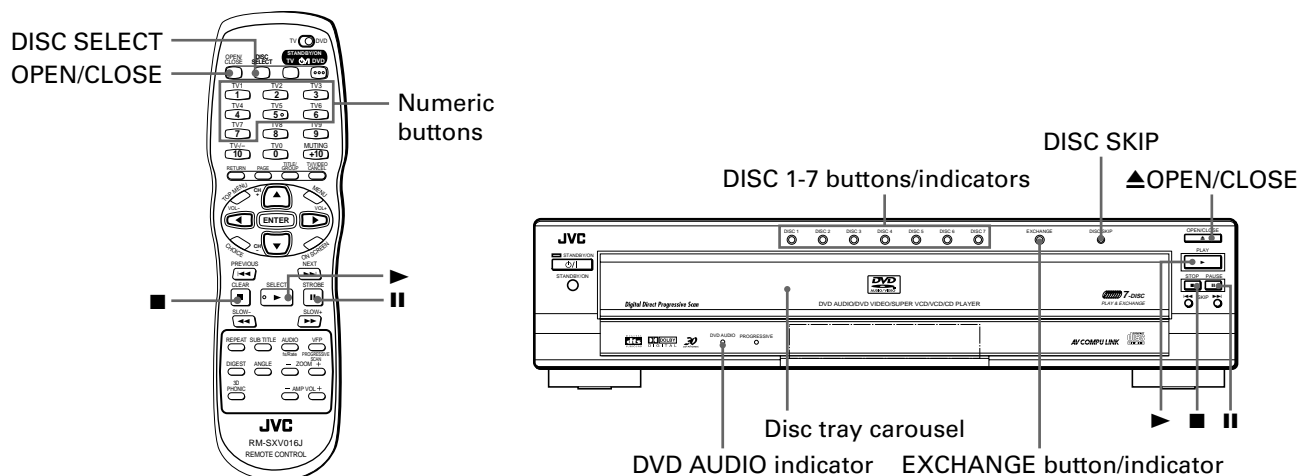

## Inserting and removing discs

Up to 7 discs can be set on the disc tray carousel.

**1** Press ▲ OPEN/CLOSE to open the disc tray carousel.

You can access to two of seven trays.

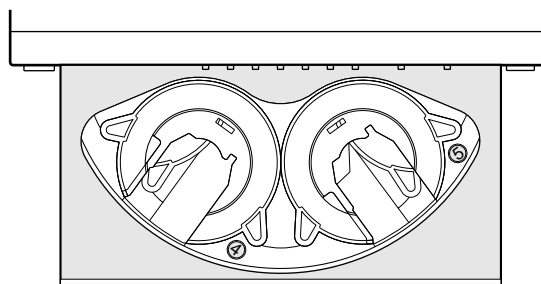

### Hints

- From the second time, the carousel opens with the previously played disc on the front-left tray.

**2** Press DISC SKIP to select accessible trays if required.

Each press of the button rotates the carousel clockwise by an amount for accessing the next two trays.

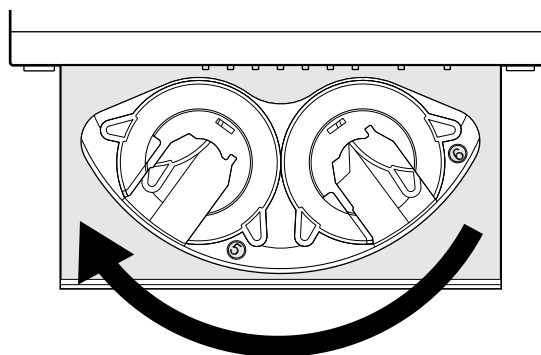

### 3 Place one or two discs in the disc tray(s).

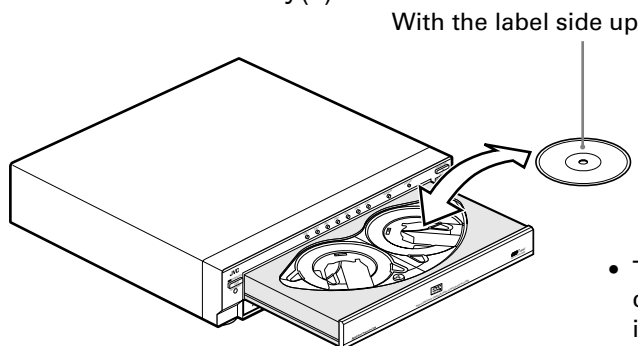

- To insert an 8-cm disc, place it in the inner recess.

### 4 Repeat steps 2 and 3 if you wish to set one or more discs to other disc trays.

### 5 Press ▲ OPEN/CLOSE to close the carousel.

The carousel closes and the DISC 1 to 7 indicators corresponding to the loaded disc numbers are turned on. The disc set in the front-left tray when the carousel closes is loaded for playback. If no disc is set in the front-left tray when the carousel closes, the unit rotates the carousel clockwise until it finds a disc for loading. The unit reads the disc information and the opening display appears on the TV screen (see page 14). When a DVD AUDIO disc is loaded, the DVD AUDIO indicator lights in blue.



#### If a menu is shown on the TV screen

When inserting a DVD AUDIO, DVD VIDEO, SVCD, or Video CD disc, a menu display may be automatically shown on the TV screen (see pages 30, 31). From a menu, you can select a desired item to be played back by following the procedure below.

#### (for DVD AUDIO/DVD VIDEO)

- 1 Use ▲/▼/◀/▶ to select a desired item.
- 2 Press ENTER.  
The unit starts playback of the selected item.

#### (for SVCD/Video CD)

- Use the numeric buttons to select a desired item.  
The unit starts playback of the selected item.

#### NOTES

- Do not load a non-playable disc. For details about playable and non-playable disc types, see page 4.
- When loading a disc on the tray, be sure to position the disc inside the recess. Otherwise, the disc may be damaged when the carousel is closed, or the disc may not be removed from the unit.
- Do not use any stabilizer when playing back a disc.
- With some DVD VIDEO discs, the unit starts playback automatically after inserting the disc.
- If you insert a DVD VIDEO disc whose region code does not match the unit, "REGION CODE ERROR!" is shown in the opening display. For detail about the region code, see page 4.

## To start playback

Available :     

Press .

or

Press a desired DISC (1 to 7) button on the front panel, or press DISC SELECT followed by a desired numeric (1 to 7) button on the remote control unit.

By the former operation (pressing ) , the unit starts playback from the disc loaded for playback after closing the disc carousel (see page 17 for details about which disc is loaded for playback).

By the latter operation (using DISC 1 to 7, or DISC SELECT + numeric buttons), the unit starts playback from the disc set in the specified tray. If no disc is set in the specified tray, the unit rotates the carousel clockwise until it finds a disc for playback.

You can skip the disc which is just played back to a next one and the unit plays back the next disc. To skip the disc, press DISC SKIP. If a disc is not set in the next tray, the unit searches an available disc until the tray takes around. Regardless of operations for starting playback, the unit plays back all available discs sequentially until you stop playback. However, the unit stops playback after the playback of the disc 7.

With some discs, which automatically goes to the menu screen and waits for the next instruction, the unit does not move to the next disc.

### About DISC 1 to 7 indicators

DISC 1 to 7 indicators show the current status of the corresponding disc tray as follows.

- Illuminates if a disc is set in the corresponding disc tray.
- Flashes when the corresponding disc is being played back.
- Unlit if no disc is set in the corresponding disc tray.



#### About screen saver function

- A television monitor screen may be burned out if a static picture is displayed for a long time. To prevent this, the unit automatically activates the screen saver function if a static picture, such as an on-screen display or menu, is displayed for over 5 minutes.
- Pressing any buttons on the unit or the remote control unit will release the screen saver function and return to the previous display.
- You can also turn off the screen saver function (see page 64).
- The screen saver function does not work for still images during DVD AUDIO playback.

While the screen saver function is not activated











While the screen saver function is activated



#### About On-screen guide icons

- When you make an operation, you may see the following icons displayed over the picture for about 3 seconds. These have the following meanings.

You can set the unit not to display these icons below via the preference settings described on page 67.

Icon	Status
	Appears at the beginning of playback mode.
	Appears at the beginning of pause mode.
	Appears at the beginning of fast forward/backward playback with the current speed (see page 26).
	Appears at the beginning of slow-motion playback with the current speed (see page 26).
	Appears at the beginning of a scene recorded from multiple angles (see page 41).
	Appears at the beginning of a scene recorded with multiple audio languages (see page 40).
	Appears at the beginning of a scene recorded with multiple subtitle languages (see page 39).
	Appears when the unit does not accept your operation because of disc contents, structure, playback status etc. Note that some operations are occasionally unacceptable even if  is not displayed. (This icon appears even when ON SCREEN GUIDE in the preference display is set to OFF.)

**NOTES**

- Once a disc tray whose status is known by the unit becomes accessible when the carousel opens, the corresponding indicator lights even if the disc is not set.
- When the RESUME function is "ON" or "DISC RESUME" and the resume point is memorized, pressing ► starts playback from that point instead of the beginning. See page 23.
- During playback, the display window shows the title/chapter, group/track, or track number being played.
- During DVD VIDEO playback, pressing ► moves back the playback position 10 seconds before the current position. See page 21 for details.
- When a DVD disc is set in the front-left tray, the unit usually starts playback automatically after closing the carousel and reading the disc contents.

**To stop playback completely**Available :     

Press ■.

The unit stops playback.



- If you press ▲ OPEN/CLOSE during playback, the unit stops playback and opens the disc tray carousel.

**To stop playback temporarily**Available :     

Press ■■.

The unit pauses playback. To resume playback, press ►.

**To change discs during playback [EXCHANGE]**Available :     

You can open the disc tray carousel during playback and change discs that are not being played back.

- During playback (with the carousel closed)

In this condition, you can see the EXCHANGE indicator is illuminated in green.

**1** Press EXCHANGE.

The carousel opens without interrupting playback.

"EXCHANGE" is briefly shown in the display window.

**2** Set, remove or change discs in the accessible disc trays.**3** To access to the other trays, press DISC SKIP.

Each press of the button rotates the carousel, however, the disc tray corresponding to the disc being played back is never accessible.

**4** Press EXCHANGE or ▲OPEN/CLOSE.

The carousel closes.

**NOTES**

- During the steps 2 and 3 above, only the ■, ■■, |◀◀/▶▶| and ◀◀/▶▶ buttons are effective for the disc being played back.
- The EXCHANGE button does not work during program playback.

## To move back the playback position while DVD VIDEO playback [One touch replay function]

Available : 

During playback of a DVD VIDEO disc, you can move back the playback position 10 seconds from the current position.

- During DVD VIDEO playback

Press ►.

The playback position moves back 10 seconds before the current position.

Note that this function works only in the same title, though it works between chapters.

If you press ► within 10 seconds from the beginning of a title, playback starts from the beginning of the title.

### **NOTES**

- This function works only with DVD VIDEO discs.
- When  appears on the TV screen:  
Some DVD VIDEO discs may not accept this function because of disc contents.

## Resuming playback

The unit can memorize the position on a disc where you interrupt playback, and resume playback from that position later. There are two resume modes (DISC RESUME and ON) you can set on the preference display. See page 67 for details about how to set the resume mode.

### Hints

- When purchasing the unit, the resume mode is initially set to "ON".
- You can deactivate the resume mode by setting "RESUME" on the "OTHERS" preference display to "OFF".

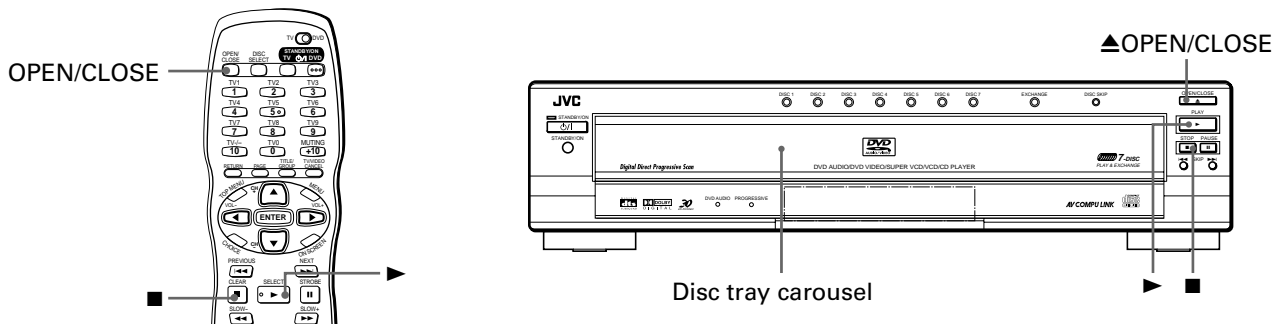

## To memorize the interrupted position

Available : **DVD AUDIO** **DVD VIDEO** **Super VCD** **Video CD**

- During playback

### When the resume mode is set to "DISC RESUME"

Press ■.

The unit stops playback and memorizes the interrupted position. After pressing ■, the display window on the front panel shows "----RESUME" (DVD AUDIO/DVD VIDEO) or "--RESUME" (SVCD/Video CD).

In this condition, a memory of the interrupted position is not cleared if you press ▲ OPEN/CLOSE to open the disc tray carousel, or press DVD STANDBY/ON ⏻ on the remote control unit or STANDBY/ON ⏻ on the front panel to turn off the unit.

### Hints

- If you do not want the disc played to resume playback, press ■ while stopped.
- It memorizes positions interrupted for the last 30 discs.
- If you interrupt playback of a disc which you resumed playback, the memory is updated to store the new interrupted position.
- When the unit has already memorized positions for 30 discs, memorizing one more position for a disc automatically erases the oldest memory. On the other hand, if you interrupt playback of a disc which an interrupted position is already memorized, the order of memorized discs may change. In result, when memorizing a new data, the order of memorized discs to be erased also may change.

### When the resume mode is set to "ON"

Press ■.

The unit stops playback and memorizes the interrupted position. After pressing ■, the display window on the front panel shows "----RESUME" (DVD AUDIO/DVD VIDEO) or "--RESUME" (SVCD/Video CD).

In this condition, a memory of the interrupted position is not cleared until you press OPEN/CLOSE, DVD STANDBY/ON ⏻ on the remote control unit or ▲ OPEN/CLOSE, STANDBY/ON ⏻ on the front panel.

### Hints

- If you do not want the disc played to resume playback, press ■ while stopped.



## To resume playback

Available :    

### When the resume mode is set to "DISC RESUME"

- While stopped, or no disc is inserted

**1** Press  OPEN/CLOSE to insert a disc whose interrupted position is memorized.

After loading the disc, the display window on the front panel shows "----RESUME" (DVD AUDIO/DVD VIDEO) or "--RESUME" (SVCD/Video CD) and "RESUME STOP" appear at the bottom of the opening display.

If a disc for which you want to resume playback is already set in the disc tray carousel, you need not to follow this step.





**2** Press .

The display window shows "RESUME PLAY" and the unit resumes playback from the position you interrupted playback.

The unit keeps the memory for the position on a disc where you interrupted playback, even though you remove the disc from the disc tray carousel and set it back again.

Of course, the unit keeps the memory when the disc remains in the disc tray since the last playback.

- **To play back a disc from the beginning (instead of the interrupted position)**

After loading the disc, press  before pressing  to start playback.

Pressing  while the disc is stopped clears the memory for the interrupted position.

Every time you interrupt playback, the position is memorized as the "resuming" point.

### When the resume mode is set to "ON"

- While the disc you interrupted playback last time\* is still on the disc tray (\*by pressing .

Press .



The display window shows "RESUME PLAY" and the unit resumes playback from the position you interrupted playback.

If you press  then , the unit starts playback after the display window shows "RESUME PLAY."

Note that you cannot resume playback if you interrupted playback last time by opening the carousel or turning off the power.

- **To play back a disc from the beginning (instead of the interrupted position)**

Carry out any of the followings:

\* Press  while stopped, then press .

\* Turn off and on the unit by pressing DVD STANDBY/ON  on the remote control unit or STANDBY/ON  on the front panel then press .

#### NOTES

- If you change the "RESUME" setting on the "OTHERS" preference display to "OFF" or "ON" from "DISC RESUME," you cannot resume playback of a disc whose "resuming" position is memorized. However, if you again set "RESUME" to "DISC RESUME," you can resume playback of the disc.
- If you open the carousel with the RESUME mode set to ON, the "resuming" point clears.
- The resume function cannot be performed with Audio CD, MP3 and JPEG discs.
- In the case of an SVCD/Video CD disc with PBC function, the unit may resume playback from a point slightly earlier or later than the point you interrupt playback last time.
- The unit may not resume playback exactly from the interrupted point, depending on the point.
- For a double-sided DVD AUDIO/DVD VIDEO disc, the unit regards each side as a different disc. Therefore, when resuming playback of such a disc, make sure to set the disc with the resumed side down.
- When the unit memorizes the interrupted point of a disc, it also memorizes Audio, Subtitle and Angle settings (regardless of whether "RESUME" is set to "DISC RESUME" or "ON").
- If you interrupt playback while the menu for a DVD AUDIO, DVD VIDEO, SVCD or Video CD is shown on the TV screen, the unit may not memorize the interrupted position correctly, regardless of whether the "RESUME" mode is set to "ON" or "DISC RESUME."

## To locate the beginning of the scene or song

You can locate the desired group or track (for DVD AUDIO), title or chapter (for DVD VIDEO), or track (for SVCD/Video CD/ Audio CD) from which the unit starts playback.

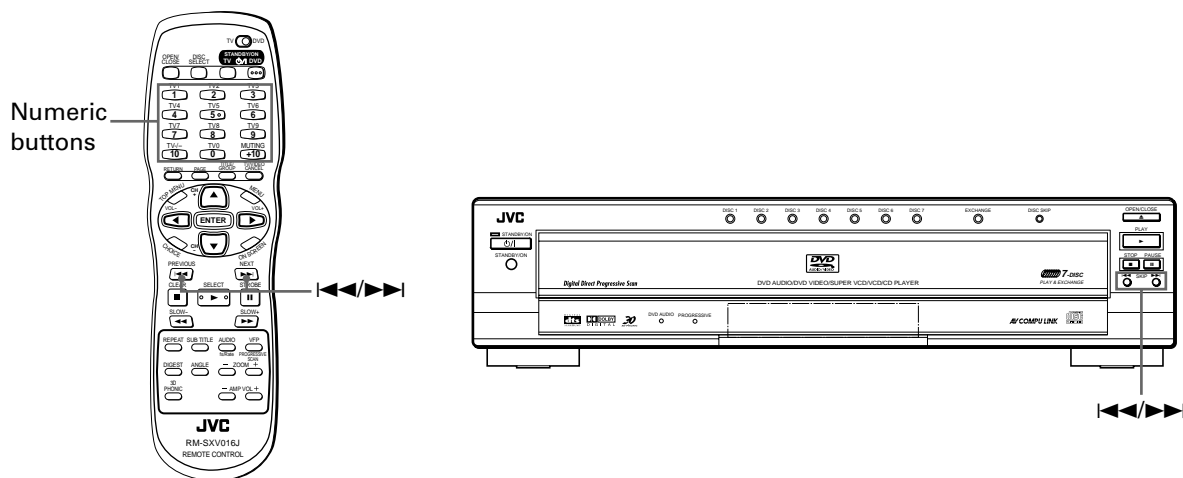

## To locate a desired selection using ◀◀ or ▶▶

Available : **DVD AUDIO** **DVD VIDEO** **Super VCD** **Video CD** **Audio CD**

- For DVD AUDIO/Audio CD: During playback or while stopped
- For DVD VIDEO: During playback
- For SVCD/Video CD: During playback without PBC function

Press ◀◀ or ▶▶.

With a DVD AUDIO, pressing the button skips a group or track depending on the disc configuration. With a DVD VIDEO, pressing the button skips a chapter or title depending on the disc configuration. With an SVCD, Video CD or Audio CD, pressing the button skips a track.

The selection number appears in the display window on the front panel.

- To skip forward titles/chapters/groups/tracks, press ▶▶ as many times as required.
- To skip to the beginning of the current titles/chapters/groups/tracks, press ◀◀ once.
- To skip back titles/chapters/groups/tracks, press ◀◀ as many times as required.

### NOTES

- This function may not work with some DVD VIDEO discs.
- This function does not work during SVCD/Video CD playback with PBC function (see pages 5 and 30).

## To locate a desired selection using the numeric buttons

Available :     

- For DVD AUDIO/DVD VIDEO/Audio CD: During playback or while stopped
- For SVCD/Video CD: During playback without PBC function or while stopped

Use the numeric buttons to specify the number.

Depending on the disc type and the unit status, what is specified differs.

Unit status	Disc type	What is specified
While stopped	DVD AUDIO	group or track* <sup>1</sup>
	DVD VIDEO	title or chapter* <sup>2</sup>
	SVCD/Video CD/Audio CD	track
During playback	DVD AUDIO	track
	DVD VIDEO	chapter
	SVCD/ Video CD/Audio CD	track

- \*<sup>1</sup> Pressing the numeric buttons simply selects a track. To select a group (when a disc contains more than one group), press TITLE/GROUP before pressing the numeric buttons.
- \*<sup>2</sup> Pressing the numeric buttons simply selects a chapter when a disc contains only one title, or selects a title when a disc contains more than one title.

The selected title, group or track number appears in the display window on the front panel.

- To select a number between 1 and 10: Press the corresponding button for the number.
- To select a number higher than 10: Use the +10 button.

Examples:

To select 13: +10 → 3

To select 34: +10 → +10 → +10 → 4

To select 40: +10 → +10 → +10 → 10

The unit starts playback from the beginning of the selection. The selected title, chapter, group or track number appears in the display window on the front panel.

### NOTES

- You can also specify the desired title during DVD VIDEO playback. See page 31 for details.
- During DVD AUDIO/DVD VIDEO playback, if a menu is shown on the TV screen, the numeric buttons may be used for selecting an item in the menu.
- When  appears on the TV screen:  
The title, chapter, group or track you have selected is not contained in the disc.
- This function does not work during SVCD/Video CD playback with PBC function (see pages 5 and 30).



## Other convenient functions

You can check the playback status, as well as change the brightness of the display window.

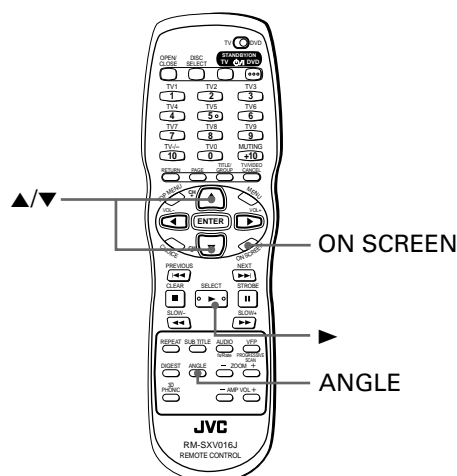

## To check the playback status

Available : **DVD AUDIO** **DVD VIDEO** **Super VCD** **Video CD** **Audio CD**

You can see the current selection number (the group/track number for DVD AUDIO, the title/chapter number for DVD VIDEO or the track number for SVCD/Video CD/Audio CD), time information (the track, group or chapter time while stopped, or the elapsed track, group or chapter time during playback) and the transport status (stop, playback, pause etc.) on the TV screen.

- During playback or while stopped

Press ON SCREEN.

The playback status bar appears on the TV screen.

(for DVD AUDIO)

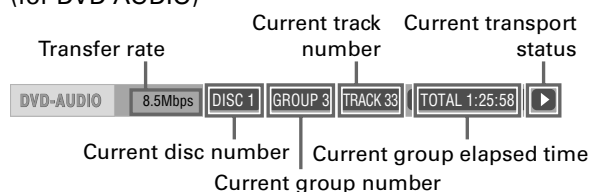

(for SVCD)

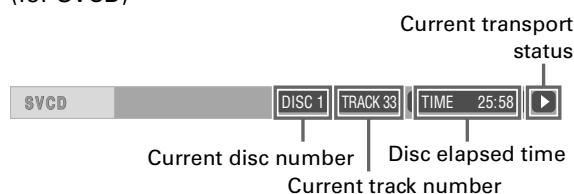

(for Audio CD)

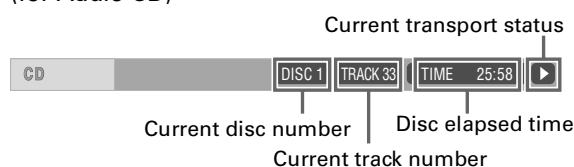



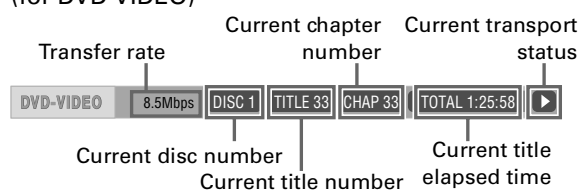

(for DVD VIDEO)

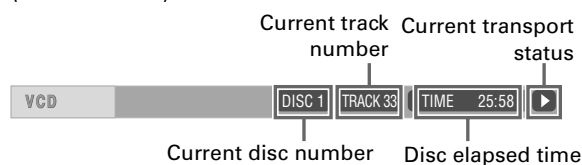

(for Video CD)



The indication on the right most of the status bar shows the unit's transport status as follows:

Icon	Status
	Appears in the playback mode.
	Appears in the stop mode.
	Appears in the pause mode.
	Appears in the fast forward/backward playback mode.
	Appears in the slow-motion playback mode.

Note that pressing ON SCREEN again brings up the menu bar under the status bar, from which you can access various functions.

(Example of the menu bar for DVD VIDEO)



See page 46 for details about the menu bar.

#### NOTES

- **To dismiss the status bar:**  
Press ON SCREEN until the status bar is dismissed.
- **The status bar cannot be displayed during MP3/JPEG playback.**

## To change the brightness of the display window

You can dim the brightness of the display window.

Press ▲ or ▼ while holding down ANGLE.

You can select the brightness of the display window from among four levels. Each time you press the button, the brightness changes among low, middle, high, and off.

This chapter describes operations for various advanced functions of DVD AUDIO, DVD VIDEO, SVCD, Video CD and Audio CD discs. For MP3 and JPEG disc playback, see the separate chapters on and after pages 51 and 55.

The following table shows the contents of this section together with effective disc types for each operation.

Function	DVD AUDIO	DVD VIDEO	Super VCD	Video CD	Audio CD	Page
<b>Playing from a specific position on a disc</b>						
To locate a desired scene from the DVD menu	yes	yes				30
To locate a desired scene from the menu of the SVCD/Video CD with PBC			yes	yes		30
To specify a desired title/group	yes	yes				31
To locate a desired position in the current title, group or track [Time search]	yes	yes	yes	yes	yes	31
To locate a desired scene from the display [DIGEST]		yes	yes	yes		32
To select a still picture on a DVD AUDIO disc [PAGE]	yes					33
To play back a bonus group of a DVD AUDIO disc	yes					34
<b>Changing the playback order</b>						
To play back in the desired order [Program playback]	yes		yes	yes	yes	35
To play back in random order [Random playback]	yes		yes	yes	yes	36
<b>Repeat playback</b>						
To repeat the current selection or all tracks [Repeat playback]	yes	yes	yes	yes	yes	37
To repeat a desired part [A-B repeat playback]	yes	yes	yes	yes	yes	38
<b>Changing the language, sound and scene angle</b>						
To select the subtitle language [SUB TITLE]	yes*	yes	yes			39
To change the audio language or sound [AUDIO]	yes	yes	yes	yes		40
To select a scene angle of DVD VIDEO [ANGLE]		yes				41
<b>Special picture playback and picture/sound effect</b>						
To display continuous still pictures [STROBE]		yes	yes	yes		42
To zoom in/out pictures [ZOOM]	yes*	yes	yes	yes		43
To adjust the picture character [VFP]	yes*	yes	yes	yes		43
To simulate surround sound [3D PHONIC]		yes				44
<b>Checking the sampling frequency and bit rate</b>	yes	yes	yes	yes	yes	45

\* In the table above, "yes" shows that the corresponding function is effective to non-audio information (such as movies, still pictures and text data) if recorded on a DVD AUDIO disc.

**NOTE**

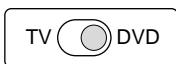

Make sure that the TV - DVD switch on the remote control unit is set to "DVD" when using the ▲/▼/◀/▶, numeric and TV/VIDEO - CANCEL buttons for controlling the unit.

## Playing from a specific position on a disc

You can play a disc from the selected track, title, group or chapter, or from the specified time.

### To locate a desired scene from the DVD menu

Available :  

DVD AUDIO/DVD VIDEO discs generally have their own menus which show the disc contents. These menus contain various items such as titles of movies, names of songs, or artist information, and display them on the TV screen. You can locate a desired scene by using the DVD menu.

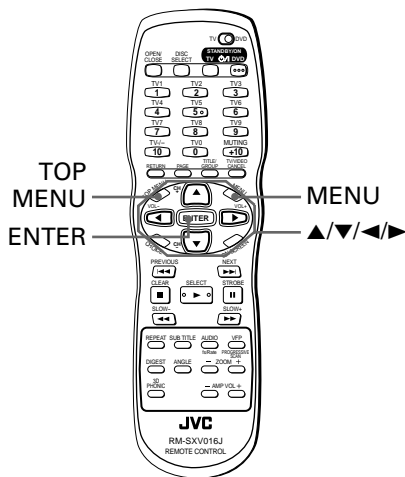

- Whenever a DVD AUDIO/DVD VIDEO disc is loaded

#### 1 Press TOP MENU or MENU.

The menu appears on the TV screen.

Example:

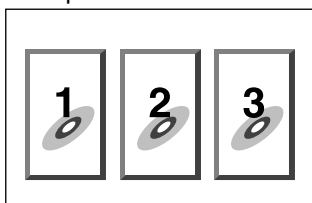

#### About DVD menu

Normally, a DVD AUDIO disc which contains more than one group may have a "top" menu which lists the groups. Similarly, a DVD VIDEO disc which contains more than one title may have a "title" menu which lists the titles. In such a case, the menu appears on the TV screen by pressing the TOP MENU button. Some DVD AUDIO/DVD VIDEO discs may also have a different menu which appears by pressing the MENU button.

See the instructions of each DVD AUDIO/DVD VIDEO disc for its particular menu.

#### 2 Use ▲/▼/◀/▶ to select a desired item, then press ENTER.

The unit starts playback of the selected item.



- With some discs, you can also select items by entering the corresponding number using the numeric buttons, which may cause the unit to automatically start playback.

#### NOTES

- When  appears on the TV screen by pressing TOP MENU or MENU in step 1:  
The disc does not have an appropriate menu listing the titles or groups.
- The MENU button does not work while stopped.

### To locate a desired scene from the menu of the SVCD/Video CD with PBC

Available :  

Some SVCD/Video CD discs support the PBC function. PBC is an abbreviation of "PlayBack Control." An SVCD/Video CD disc recorded with PBC has its own menus, such as a list of the songs of the disc. You can locate a specific scene by using the PBC menu.

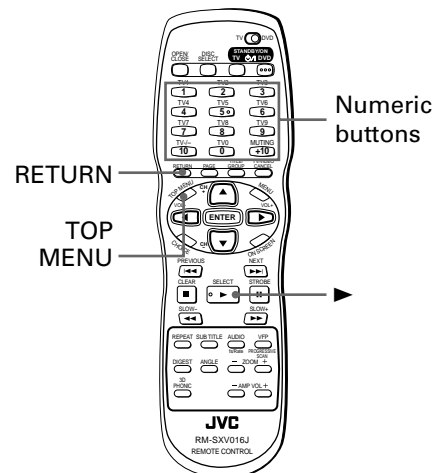

- When an SVCD/Video CD disc with PBC is stopped

#### 1 Press ▶ or TOP MENU.

A disc menu appears on the TV screen (the PBC function is activated).

Example:

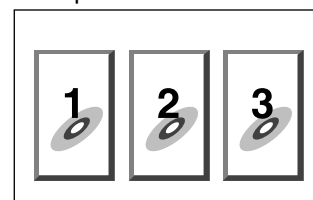

"PBC" is indicated in the display window on the front panel.



## 2 Use the numeric buttons to select the desired item.

- To select a number between 1 and 10:  
Press the corresponding button for the number.
- To select a number higher than 10:  
Use the +10 button.

Examples:

- To select 13: +10 → 3
- To select 34: +10 → +10 → +10 → 4
- To select 40: +10 → +10 → +10 → 10

The unit starts playback of the selected item. You can return to the menu by pressing the RETURN button.

When something like "NEXT" or "PREVIOUS" appears on the TV screen, the unit generally works as follows:

- Pressing ►► advances to the next page.
- Pressing ◄◄ returns to the previous page.
- \* The method of the operation is different depending on the disc.



- If you want to playback a PBC-compatible SVCD/Video CD disc without activating the PBC function, start playback by using the numeric buttons instead of ► (see page 25).
- To activate the PBC function when a PBC-compatible SVCD/Video CD disc is being played back without the PBC function, carry out any of the followings:
  - \* Press TOP MENU or MENU.
  - \* Press ■ to stop playback, then press ► .

## To specify a desired title/group

Available : **DVD AUDIO** **DVD VIDEO**

While playing back a DVD AUDIO/DVD VIDEO disc with more than one title or one group, you can specify a desired title or group to be played using the numeric buttons.

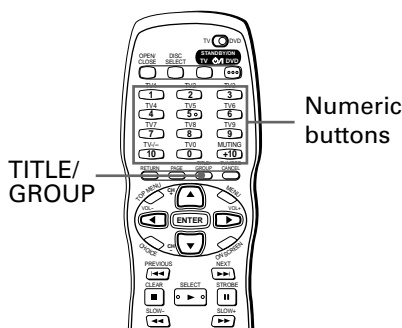

- During playback

### 1 Press TITLE/GROUP.

"--" is shown in the title display area of the display window.  
(Display window example for DVD VIDEO)

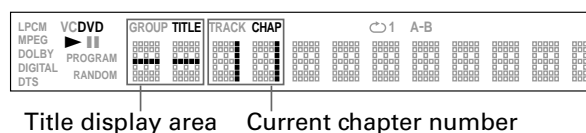

Title display area      Current chapter number

## 2 Use the numeric buttons to specify a title or group to be played.

- To select a number between 1 and 10:  
Press the corresponding button for the number.
- To select a number higher than 10:  
Use the +10 button.

Examples:

- To select 13: +10 → 3
- To select 34: +10 → +10 → +10 → 4
- To select 40: +10 → +10 → +10 → 10

The unit starts playback from the specified title or group.

### NOTE

- Some DVD AUDIO/DVD VIDEO discs may not accept this function because of disc contents.

## To locate a desired position in the current title, group or track [Time search]

Available : **DVD AUDIO** **DVD VIDEO** **Super VCD** **Video CD** **Audio CD**

You can play a disc from the desired position by specifying the elapsed time from the beginning of the current group (for DVD AUDIO), the current title (for DVD VIDEO) or the disc (for SVCD/Video CD/Audio CD) using the time search function.

Note that some DVD VIDEO discs do not contain time information, and the time search function cannot be used.

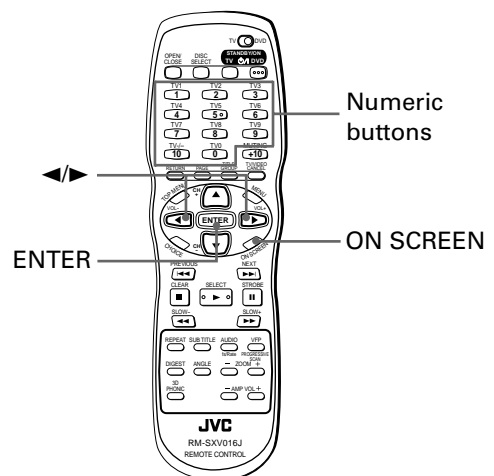

- For DVD AUDIO/DVD VIDEO/Audio CD:  
During playback or while stopped
- For SVCD/Video CD:  
In any condition except SVCD/Video CD playback with PBC

### 1 Press ON SCREEN twice.

The menu bar appears on the TV screen.  
(See page 46 for details about the menu bar.)

2 Use to move to , then press ENTER.

The pull-down menu for entering time appears under the .

(Screen example for DVD VIDEO)

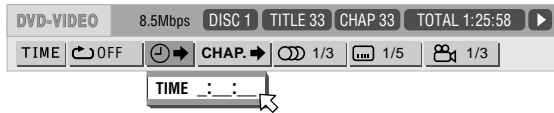

(Screen example for Audio CD)



3 Use the numeric buttons (0 to 10) to enter the desired time.

The specified time is displayed in the pull-down menu.

Hints

- "10" button works as "0" and "+10" button is not used with this function.
- You can specify the time in hour/minute/second format for DVD AUDIO/DVD VIDEO discs, and in minute/second format for SVCD/Video CD and Audio CD discs.

• **Example (for DVD AUDIO/DVD VIDEO)**

To play back from 2(H):34(M):00(S)

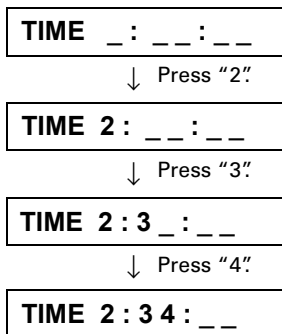

• **Example (for SVCD/Video CD/Audio CD)**

To play back from 23(M):40(S)

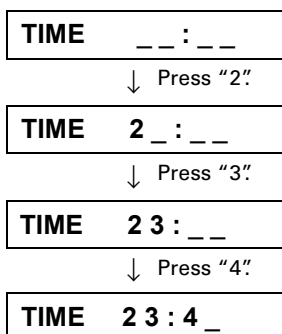

You do not have to press "0" to enter the trailing zeros (for the last two digits in the example above).

• **When you correct a mistake**

Use repeatedly to move back to the digit where you entered a undesired numeral (the leftmost "-" digit), and reenter the correct time.

(Example for changing "2:35:\_" to "2:34:\_.")

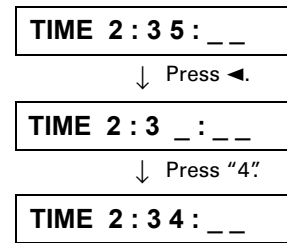

4 Press ENTER.

The unit starts playback from the specified time.

**NOTES**

- **When a DVD AUDIO disc is stopped, you can specify the elapsed time from the beginning of group 1.**
- **When appears on the TV screen:**  
The time you have selected is not contained on the disc, or the time search function does not work on the disc.  
Also note that the time search function does not work during SVCD/Video CD playback with the PBC function.
- **To dismiss off the menu bar:**  
Press ON SCREEN.
- **The time search function cannot be used during program playback.**

**To locate a desired scene from the display [DIGEST]**

Available :

The unit can display the opening scene of each title or chapter on a DVD VIDEO or each track of an SVCD/Video CD. You can select a desired scene from those displayed on the TV screen.

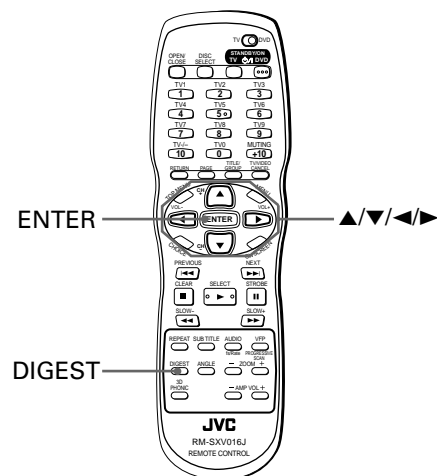

- **For DVD VIDEO:** During playback or while stopped
- **For SVCD/Video CD:** In any condition except SVCD/Video CD playback with PBC

## 1 Press DIGEST.

Up to nine opening scenes are displayed.



Depending on the disc type and whether the disc is being played back or not, the contents shown on the TV screen differ.

Disc type	Unit status	What is displayed
DVD VIDEO	While stopped	The opening scene of each title
	During playback	The opening scene of each chapter in the current title
SVCD/ Video CD	While stopped or during playback	The opening scene of each track

## 2 Use ▲/▼/◀/▶ to move to the desired scene.

If there are more than nine scenes, the digest screen will have more than one page. In this case, pressing ▶ advances to the next page, and pressing ◀ returns to the previous page.



Selected scene



- When the lower right scene is selected, pressing ▶ advances to the next page if available. Similarly, when the upper left scene is selected, pressing ◀ returns to the previous page (if available).
- Depending on discs, it may take some time until all scenes of the current page appear on the TV screen. If you want to turn the page, you do not have to wait to press ◀ or ▶ until all scenes appear.

## 3 Press ENTER.

The unit starts playback from the selected scene.

### NOTE

- With some discs, depending on the contents, it may take some times until all the scenes appear on the screen.

## To select a still picture on a DVD AUDIO disc [PAGE]

English

Available :

Most DVD AUDIO discs include still pictures, which usually appear in turn automatically during playback according to the playback sequence. However, there are other page(s) of the current still picture and you can change the picture (turn the page) manually.



- At the beginning of a part where there are selectable pictures, "PAGE" appears on the TV screen (except when the "ON SCREEN GUIDE" preference is set to "OFF"). See page 67 for details about "ON SCREEN GUIDE" preferences.

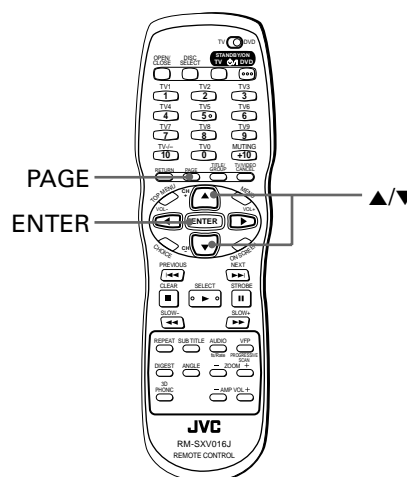

- During playback (except when the status bar is shown)

## 1 Press PAGE.

The Page selection window appears on the TV screen.

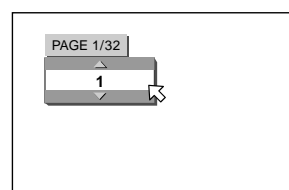

## 2 Use PAGE or ▲/▼ to select the desired page.

Each time you press PAGE or ▲/▼, the page number changes.

## 3 Press ENTER.

The selected page (picture) is shown. The Page selection window is dismissed.

### NOTE

- The Page selection window will automatically disappear if you do not change the page for several seconds.
- You can also select the page via the menu bar. See page 48.

## To play back a bonus group of a DVD AUDIO disc

Available : 

Some DVD AUDIO discs contain a special group called "bonus group" whose contents are not opened to the public. The bonus group is always assigned to the last group of a disc (for example, if a disc contains four groups including a bonus group, "group 4" is the bonus group).

To play back a bonus group, you have to enter the specific "key number" (a kind of password) for the bonus group. A way of getting the key number depends on discs.

After getting the key number, you can play back the bonus group by the following procedure.

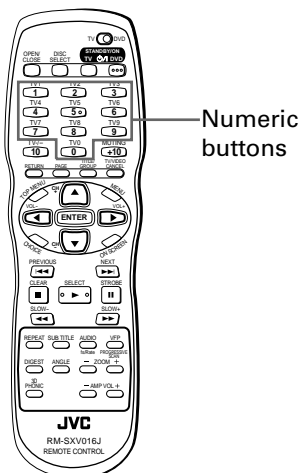

- While a disc containing a bonus group is stopped

### 1 Use the numeric buttons to select the bonus group number (the last group).

The display window and on-screen display prompt you to enter the key number as shown below.

(Display Window)



(TV screen)

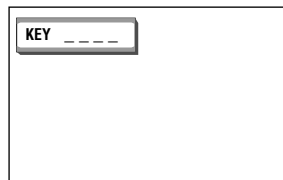

### 2 Use the numeric buttons (0 to 9) to enter the key number.

If you enter the key number correctly, the unit starts playback of the bonus group.

If you enter a wrong key number, the unit does not start playback and the display window and TV screen again prompt you to re-enter the key number.

### 3 Press ENTER.

#### NOTE

- Once you enter the correct key number, the unit memorizes it until you turn off the power or open the carousel.
- If you specify a track in the bonus group when programming tracks for the program playback, the display window will also show the above display for inquiring the key number.
- In the random playback mode, tracks in the bonus group are not played back.
- To turn off the key number entry display, operate any one of the following.

- \* Press .
- \* Open the disc tray carousel.
- \* Change the current disc.
- \* Turn the power off.

Opening the carousel or turning the power off also erases the memory of the key number, while pressing  does not erase the memory.

## Changing the playback order

You can play tracks on a DVD AUDIO, SVCD, Video CD or Audio CD in the desired order or in random order.

### To play back in the desired order [Program playback]

Available :    

By programming tracks, you can play up to 99 tracks in any order among multiple discs. You may program the same track more than once.

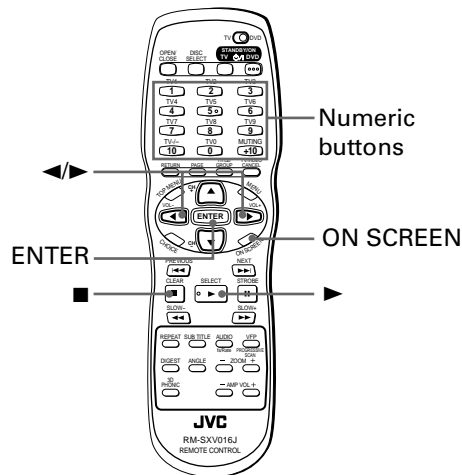

- While stopped

#### 1 Press ON SCREEN twice.

The menu bar appears on the TV screen.  
(See page 46 for details about the menu bar.)

#### 2 Use ◀▶ to move to **PROG.**

(Screen example for DVD AUDIO)



#### 3 Press ENTER.

The program table appears instead of the menu bar.  
The PROGRAM indicator lights in the display window on the front panel.

(Program table example for DVD AUDIO)

PROGRAM			
No.	Disc	Group	Track
1			
2			
3			
4			
5			
6			
7			
8			
9			
10			

USE NUMERIC KEYS TO PROGRAM TRACKS.  
PRESS ENTER TO SKIP GROUP ENTRY FOR CD.

#### 4 a (for DVD AUDIO)

Specify selections in the desired order by disc, group and track numbers using the numeric buttons.

- For each program step, using the numeric buttons, specify a disc first, then specify a group, finally, specify a track.
- For example, to specify "track 14 in group 2 of disc 3,"  
Press 3 → 2 → +10 → 4.

#### 4 b (for SVCD/Video CD/Audio CD)

Specify selections in the desired order by disc and track using the numeric buttons.

- For each program step, using the numeric buttons, specify a disc first, then press ENTER, finally specify a track.
- For example, to specify "track 14 of disc 2,"  
Press 2 → ENTER → +10 → 4.  
(You can also use any of the numeric buttons instead of the ENTER button. The number entered for the group number is invalid.)

Up to 99 tracks can be programmed. You may select the same track more than once.

(Program table example for DVD AUDIO)

Example for step 4a

Example for step 4b

PROGRAM			
No.	Disc	Group	Track
1	3	2	14
2	2		14
3	4	4	6
4	5	2	8
5	6	3	6
6	7	4	14
7	7	6	20
8			
9			
10			

USE NUMERIC KEYS TO PROGRAM TRACKS.  
PRESS ENTER TO SKIP GROUP ENTRY FOR CD.

Selected group/track number

Selected disc number

- If you specify a wrong track

Use ▲/▼ to move  to the wrong track, then press TV/VIDEO - CANCEL. The track is erased and the subsequent programmed tracks move up.

- To clear the program while programming

Press ■.

You can also clear the program by opening the carousel or changing the current disc.

## 5 Press ► to start program playback.

With a DVD AUDIO/SVCD/Video CD disc, the program table is automatically dismissed when the program playback starts.

With an Audio CD disc, the program table remains on the TV screen during program playback. However, pressing the ON SCREEN button brings up the status bar.

When all of the programmed tracks have finished playback, the unit stops and the program table appears again.

Note that the program remains.

### • To check the program contents

During playback, press ■. Playback stops and the program table is shown.

When the unit is playing back an Audio CD and the program table is not shown, you can bring up the table by carrying out steps 1 to 3.

During DVD AUDIO/SVCD/Video CD playback, you can check the program contents via the menu bar.

### • To quit program playback

Press ■. Note that the program remains.

### • To clear the program

While stopped and the program table is shown on the TV screen, press ■.

All the programmed tracks are erased. You can also clear the program mode by turning off the unit or opening the disc tray carousel.

### • To exit the program mode

After clearing all programmed tracks, press ON SCREEN.

The program table is dismissed and the status bar appears on the TV screen.

The PROGRAM indicator in the display window disappears and the unit quits program playback mode.

## NOTES

- During program playback, you cannot edit the program contents.
- During program playback, pressing ►► skip to the next selection of the program. Pressing ◀◀ returns to the beginning of the current selection.
- If you are going to program a track in the bonus group of a DVD AUDIO, the unit will ask you to enter the key number for the bonus group (see page 34).
- The resume function cannot be used with program playback.
- To dismiss the program table:  
Press ON SCREEN. The program table is dismissed and the status bar is shown.
- To dismiss the menu bar (and the status bar):  
Press ON SCREEN.
- Program playback function cannot be used during DVD VIDEO/SVCD/Video CD playback with PBC function.
- The following buttons cannot function in program playback: DISC 1-7, EXCHANGE (the indicators are turned off), DISC SKIP, DISC SELECT (on the remote control unit).
- If you want to repeat the programmed tracks, set the repeat mode during program playback.
- With some discs, program playback may not be done.

## To play back in random order [Random playback]

Available :    

You can play tracks on a disc in random order by using the random function.

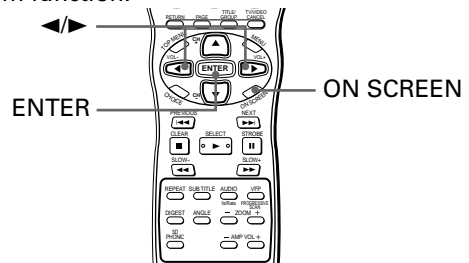

### • While stopped

#### 1 Press ON SCREEN twice.

The menu bar appears on the TV screen.  
(See page 46 for details about the menu bar.)

#### 2 Use ◀/▶ to move to RND.

(Screen example for Audio CD)

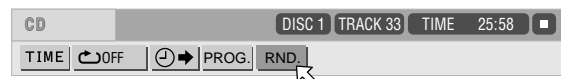

#### 3 Press ENTER.

The unit starts random playback.

With a DVD AUDIO/SVCD/Video CD disc, the menu bar is automatically dismissed.

During random playback, the RANDOM indicator lights in the display window on the front panel. After playing all tracks on the disc, the unit stops the disc and quits the random mode.

When the multiple discs are on the disc tray, the unit skips the disc to a next one and start random playback of the next disc after completing the current disc playback.



- The same track will not be played back more than once during random playback.
- During random playback, if you bring up the menu bar and carry out steps 1 to 3 above, the unit cancels the random playback mode and continues playback from the current selection in the recorded order.
- In the random playback mode with the DVD AUDIO, tracks in the bonus group are not played back (see page 34).
- To stop and quit random playback  
Press ■. The unit stops playback and quits the random playback mode.  
You can also clear the random mode by turning off the unit or opening the disc tray carousel.

## NOTES

- To dismiss the menu bar:  
Press ON SCREEN.
- Random playback is carried out only within the disc currently loaded.

## Repeat playback

You can repeat playback of the current group or track (for DVD AUDIO), current title or chapter (for DVD VIDEO) or current or all tracks (for SVCD/Video CD/Audio CD). You can also repeat playback of a desired part.

### To repeat the current selection or all tracks [Repeat playback]

Available : **DVD AUDIO** **DVD VIDEO** **Super VCD** **Video CD** **Audio CD**

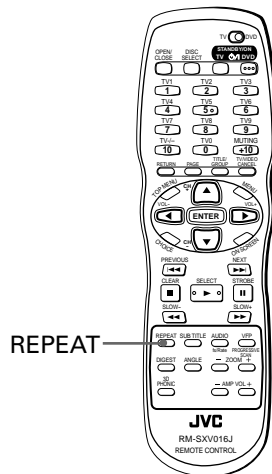

- For DVD AUDIO/DVD VIDEO: During playback
- For SVCD/Video CD/Audio CD: In any condition except SVCD/Video CD playback with PBC

#### 1 Press REPEAT.

Each time you press REPEAT, the repeat mode switches cyclically.

You can see the selected mode by icons in the display window on the front panel as below.

(Display window)



Repeat mode indicators

On the TV screen, a window for repeat mode indication appears. You can check the current repeat mode from the window.

The mode indication on the window is the same as the one on the menu bar (see pages 47, 48 and 49).

(Screen example for repeat mode indication window.)



If you press REPEAT while stopped, you need to press ► to start repeat playback.

Icons in the display window	Indications on the TV screen	Meanings
⌚	GROUP	Repeats the current group for DVD AUDIO.
	TITLE	Repeats the current title for DVD VIDEO.
	DISC	Repeats all tracks on the current disc for SVCD/Video CD/Audio CD.
	ALL	Repeats all the available discs.
⌚1	TRACK	Repeats the current track for DVD AUDIO/SVCD/Video CD/Audio CD.
	CHAP	Repeats the current chapter for DVD VIDEO.
No indication	OFF	The repeat mode is off. The unit plays back all available discs unless there is any disc that automatically pauses at the menu. However, the unit stops playback after the playback of the disc 7.

#### • To stop repeat playback

Press ■.

When an SVCD, Video CD or Audio CD disc is set, the unit stops playback but does not quit the repeat mode. When a DVD AUDIO or DVD VIDEO disc is set, the unit stops playback and quits the repeat mode.

#### • To quit repeat playback

Press REPEAT until the repeat mode indicator goes off in the display window.

You can also clear the repeat mode by opening the carousel or changing the current disc except in repeat ALL mode.

#### NOTES

- You can also select the repeat mode via the menu bar. See pages 47, 48 and 49.

- When the program playback mode is active with a DVD AUDIO, SVCD, Video CD or Audio CD, the repeat mode changes in the same manner.

Note that, however, in the "⌚" mode the unit repeats all the programmed tracks, instead of all tracks on the disc.

- During playback in the title/chapter/group/track repeat mode, if you skip the title/chapter/group/track using ◀▶, etc., the destination title/chapter/group/track is repeated.

- If ⌚ appears when pressing REPEAT during DVD VIDEO playback

You cannot repeat the title or chapter because of the disc contents.

- Repeat playback function cannot be used during SVCD/Video CD playback with PBC function.

## To repeat a desired part [A-B repeat playback]

Available : DVD AUDIO DVD VIDEO Super VCD Video CD Audio CD

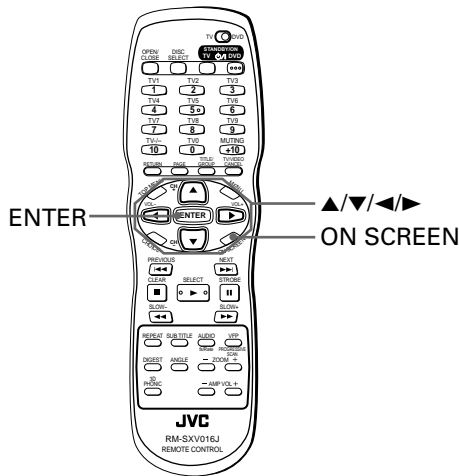

- During playback except SVCD/Video CD playback with PBC

### 1 Press ON SCREEN twice.

The menu bar appears on the TV screen.  
(See page 46 for details about the menu bar.)

### 2 Use ◀/▶ to move to , then press ENTER.

The pull-down menu for repeat mode selection appears under the .

### 3 Use ▲/▼ to select "A-B."

Depending on the disc type and unit's status the repeat mode changes as follows:

- During DVD AUDIO playback

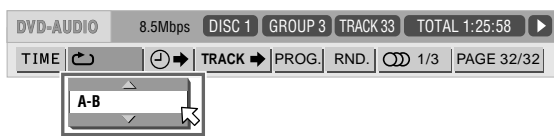

Selected repeat mode

- TRACK : current track repeat
- ↕
- GROUP : current group repeat
- ↕
- ALL : repeats all the available discs
- ↕
- A-B : repeats a desired part (during playback only)
- ↕
- OFF

- During DVD VIDEO playback

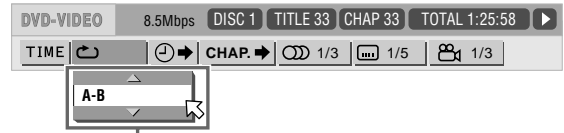

Selected repeat mode

- CHAPTER : current chapter repeat
- ↕
- TITLE : current title repeat
- ↕
- ALL : repeats all the available discs
- ↕
- A-B : repeats a desired part (during playback only)
- ↕
- OFF

- During SVCD/Video CD/Audio CD playback  
(Screen example for Audio CD)



Selected repeat mode

- TRACK : current track repeat
- ↕
- DISC : current disc repeat
- ↕
- ALL : repeats all the available discs
- ↕
- A-B : repeats a desired part (during playback only)
- ↕
- OFF

### 4 Press ENTER at the beginning of the part you want to repeat (point A).

The pull-down menu turns off.  
The repeat icon shows .

(Screen example for DVD VIDEO)



Repeat icon

### 5 Press ENTER at the end of the part you want to repeat (point B).

The repeat icon shows .

The unit locates "A" and starts repeat playback between "A" and "B."



### • To quit A-B repeat playback

Press ENTER. The A-B repeat mode turns off, while the playback continues.

You can also clear the A-B repeat mode by opening the carousel or changing the current disc.



- Selecting "OFF" from the pull-down menu for repeat mode selection, or pressing ◀▶ quits the A-B repeat mode and continues playback.
- You can also stop and quit the A-B repeat mode by pressing ■.

### NOTES

- **The A and B points must be set in the same title/ chapter/group/track.**
- **To dismiss the menu bar:**  
Press ON SCREEN.
- **If ⊘ appears when pressing ENTER during DVD VIDEO playback**  
You cannot repeat the selected portion because of the disc contents.

## Changing the language, sound and scene angle

With some DVD AUDIO/DVD VIDEO discs, you can choose a desired subtitle language and/or audio language/sound, as well as a desired camera angle. Some DVD AUDIO discs support more than one audio language/sound, with some DVD VIDEO discs support more than one subtitle language and/or audio language/sound.

Similarly, you can choose a desired audio channel (or channel combination) of an SVCD/Video CD disc, as well as a subtitle channel of an SVCD disc.

### To select the subtitle language [SUB TITLE]

Available :

Some DVD AUDIO, DVD VIDEO and SVCD discs for movies, guides, etc. contain more than one subtitle language. You can choose a desired one from them.



- At the beginning of the part where the subtitle(s) is(are) recorded, ☰ appears on the TV screen (except when the "ON SCREEN GUIDE" preference is set to "OFF"). See page 67 for details about "ON SCREEN GUIDE" preference.

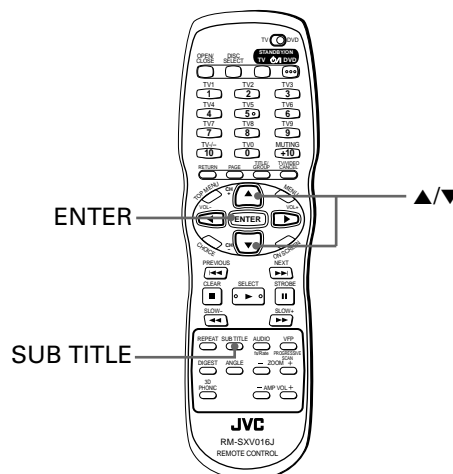

- During DVD AUDIO/DVD VIDEO/SVCD playback (except when the status bar is shown)

### 1 Press SUB TITLE.

The Subtitle selection window appears on the TV screen.

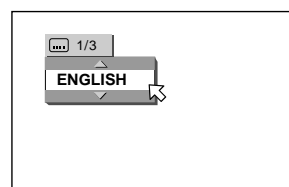

## 2 Use SUB TITLE or ▲/▼ to select the subtitle.

Each time you press SUB TITLE or ▲/▼, the subtitle language changes.

See the following examples for subtitle selection.

- **For DVD AUDIO/DVD VIDEO**

Pressing SUB TITLE or ▲/▼ cycles among the subtitles recorded on the disc.

Example:



- **For SVCD**

An SVCD disc can have up to four subtitles.

Pressing ▲/▼ cycles among those channels as follows regardless of whether the subtitles are recorded or not.

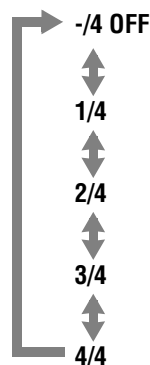

## 3 Press ENTER.

The subtitle in the selected language is shown.

The Subtitle selection window is dismissed.

### NOTES

- For DVD VIDEO, the selected language may be abbreviated on the TV screen. See "Table of languages and their abbreviations" on page 62.
- The Subtitle selection window will automatically disappear if you do not change the subtitle for several seconds.
- When  appears on the TV screen (for DVD AUDIO/DVD VIDEO disc):  
You cannot select the subtitle or no subtitle is recorded.
- You can also select the subtitle via the menu bar. See pages 49 and 51.

## To change the audio language or sound [AUDIO]

Available :    

By audio selection, you can choose the audio language of movies or enjoy KARAOKE with or without the vocal.

### Hints

- At the beginning of the part where multiple audio sounds are recorded,  appears on the TV screen (except when the "ON SCREEN GUIDE" preference is set to "OFF"). See page 67 for details about "ON SCREEN GUIDE" preference.

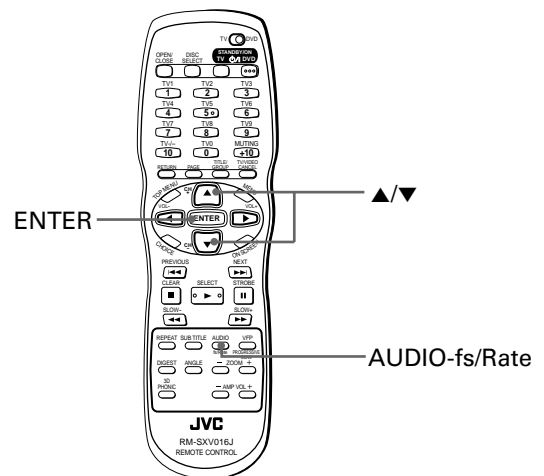

- During playback (except when the status bar is shown)

## 1 Press AUDIO-fs/Rate.

The Audio selection window appears on the TV screen.

Note that holding down AUDIO-fs/Rate for a few seconds shows the sampling frequency and bit rate (see page 45).

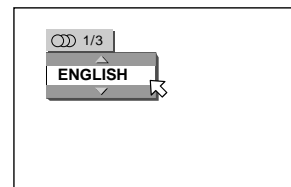

## 2 Use AUDIO-fs/Rate or ▲/▼ to select the desired audio.

Each time you press AUDIO-fs/Rate or ▲/▼, the audio changes.

See the following examples for audio selection.

- **For DVD AUDIO/DVD VIDEO**

Each time you press AUDIO-fs/Rate or ▲/▼, the audio language or sound changes.

Example:

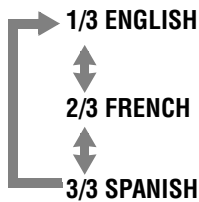

• For SVCD/Video CD

Each time you press AUDIO-fs/Rate or ▲/▼, the playback audio changes as follows.

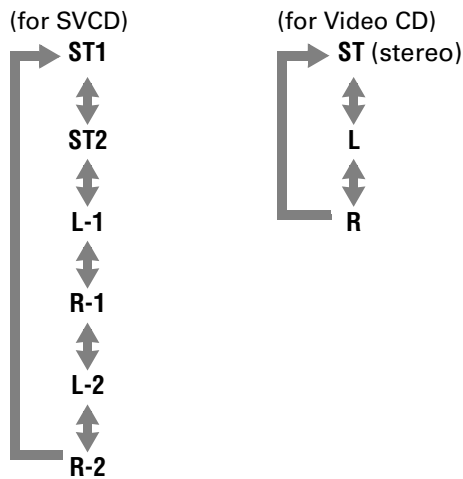

3 Press ENTER.

You can hear the selected audio.  
The audio selection window is dismissed.

**NOTES**

- For DVD VIDEO, the selected language may be abbreviated on the TV screen. See "Table of languages and their abbreviations" on page 62.
- The Audio selection window will automatically disappear if you do not change the audio for several seconds.
- When appears on the TV screen (for a DVD AUDIO/DVD VIDEO disc):  
You cannot select the audio.
- If only one audio sound is recorded, you cannot select the audio.
- You can also select the audio via the menu bar. See pages 48, 49 and 51.

**To select a scene angle of DVD VIDEO [ANGLE]**

Available :

You can enjoy a variety of scene angles if the DVD VIDEO disc contains "multi-angle" parts, where multiple cameras were used to shoot the same scene from different angles.

Hints

- At the beginning of a "multi-angle" part, appears on the TV screen (except when the "ON SCREEN GUIDE" preference is set to "OFF"). See page 67 for details about "ON SCREEN GUIDE" preference.

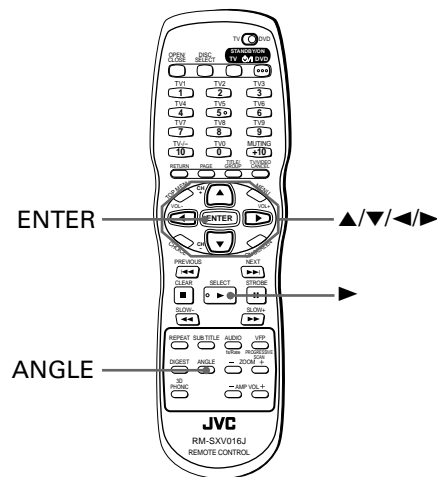

**From Angle selection window**

- During DVD VIDEO playback (except when the status bar is shown)

1 Press ANGLE.

The Angle selection window appears on the TV screen.

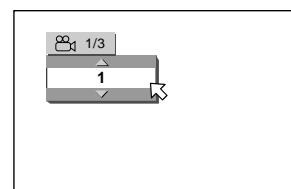

2 Use ANGLE or ▲/▼ to select the desired angle.

Each time you press ANGLE or ▲/▼, the angle changes.

Example:

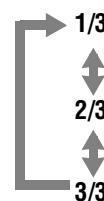

### 3 Press ENTER.

You can see the picture from the selected angle.  
The Angle selection window is dismissed.

(Display window)

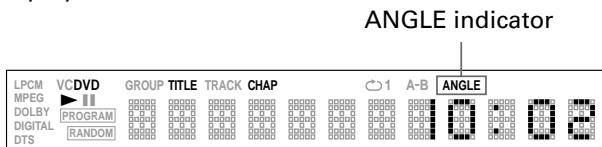

The ANGLE indicator appears during angle-selected playback.

### From the angle list

- During DVD VIDEO playback

#### 1 Press and hold ANGLE for more than 1 second.

Up to nine camera angles recorded on a disc appear on the TV screen.

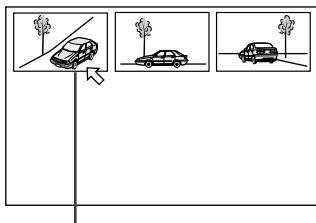

The selected camera angle

#### 2 Use ▲/▼/◀/▶ to select the desired angle.

#### 3 Press ENTER or ▶.

The unit starts playback by the selected angle on the full-sized screen.

#### NOTES

- The Angle selection window will automatically disappear if you do not change the angle for several seconds.
- When ⊙ appears on the TV screen in step 1: The current scene is not recorded from multiple angles.
- During the operation from the angle list display, audio is muted.
- You can also select the angle via the menu bar. See page 49.

## Special picture playback and picture/sound effect

You can see continuous still pictures or zoom in (or out) the picture. You can also adjust the picture character, as well as simulate surround sound using a stereo system.

### To display continuous still pictures [STROBE]

Available : DVD VIDEO Super VCD Video CD

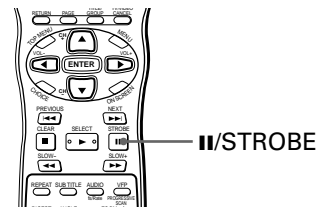

- During playback

#### 1 At the point you want to view as continuous photographs, press ||/STROBE.

The unit pauses playback.

#### 2 Press and hold ||/STROBE for more than 1 second.

Nine same frames (still pictures) appear on the TV screen.

You can advance frames one by one by the following step.

#### 3 Press ||/STROBE once.

The picture in the middle on the top row shows an advanced frame from one in the left.

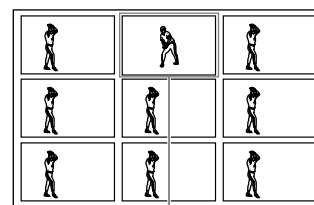

Advanced frame

Each press of ||/STROBE advances the frames one by one.

Pressing ▶ instead of ||/STROBE advances each frame in normal playback speed with a time delay over the whole nine pictures (while the sound is muted).

- To return to the normal screen

Press and hold ||/STROBE for more than 1 second.

#### NOTE

- If you press and hold ||/STROBE for more than 1 second during playback, nine still pictures also appear but they advance in normal playback speed (while the sound is muted).

## To zoom in/out pictures [ZOOM]

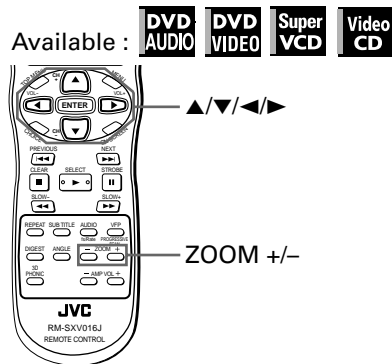

- During playback or while paused

### 1 Press ZOOM + or -.

The unit zooms in by pressing ZOOM + or zooms out by pressing ZOOM -.

Each time you press ZOOM +, the magnification is doubled (up to x 1024).

Each time you press ZOOM -, the magnification is halved (down to x 1/8).

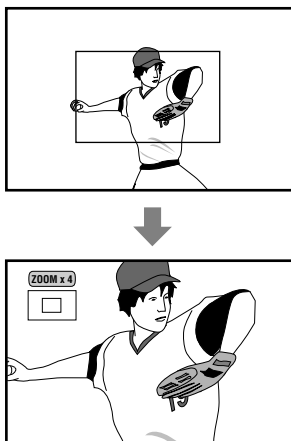

At the top-left of the screen, the information for the current magnification appears. While zoomed in, the indication for the zoomed-in position, which can be moved by operating the next step, appears together.

### 2 Use ▲/▼/◀/▶ to move the zoomed position.

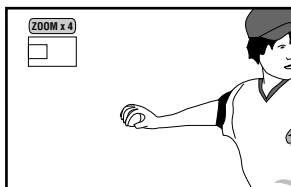

#### NOTES

- **To return to normal playback**  
Press ENTER.
- **While zoomed, the picture may look coarse.**
- **The zoom information on the screen will disappear if you do not operate the zoom function for five seconds.**
- **The indication for the zoomed-in position appears again when you press ZOOM +/-, or ▲/▼/◀/▶.**

## To adjust the picture character [VFP]

Available : DVD AUDIO DVD VIDEO Super VCD Video CD

The VFP (Video Fine Processor) function allows you to adjust the picture character according to the type of programming, picture tone or personal preferences.

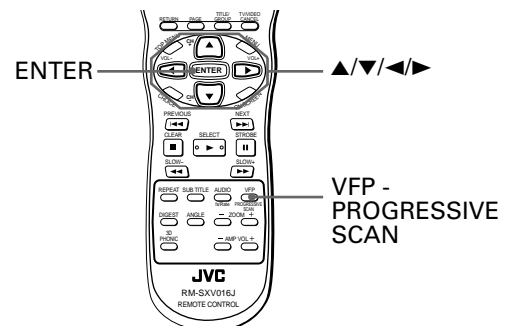

- During playback (for DVD VIDEO: During playback while picture is shown)

### 1 Press VFP - PROGRESSIVE SCAN.

The VFP mode selection window appears on the TV screen.

Note that holding down VFP - PROGRESSIVE SCAN for a few seconds changes the scanning mode (see page 8).

### 2 Use ◀/▶ to select the desired preset.

Each time you press the button, the VFP mode changes as follows.

Set the video type most suitable to the current program or the room conditions.

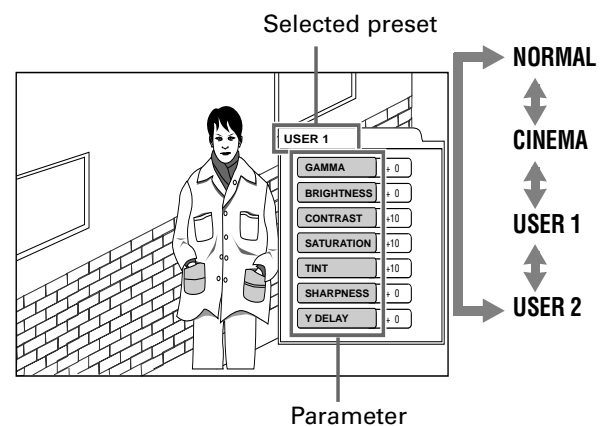

- **NORMAL**  
This mode is suitable for watching TV in a general room and you cannot change parameters.
- **CINEMA**  
This mode is suitable for watching a movie software in a room with suppressed light. They are factory presets and you cannot change parameters for them.
- **USER 1/USER 2**  
You can adjust parameters that affect the picture character and store the settings as the user preset. See the next step.

### 3 To define a user setting, select a parameter to be edited using ▲/▼ from the following.

- **GAMMA**  
Controls the brightness of a shaded portion without changing the brightness of the entire picture.  
This control is optimum when you adjust the pictures of software which generates subdued black in a bright room.  
The setting range is +4 to -4.
- **BRIGHTNESS**  
Controls the brightness of the screen.  
The setting range is +16 to -16.
- **CONTRAST**  
Controls the contrast of the screen.  
The setting range is +16 to -16.
- **SATURATION**  
Controls the color depth of the screen.  
The setting range is +16 to -16.
- **TINT**  
Controls the tint of the screen.  
Use the appearance of a natural complexion as the guideline.  
The setting range is +16 to -16.
- **SHARPNESS**  
Controls the sharpness of the screen.  
The setting range is +3 to 0.
- **Y DELAY**  
Controls the color gap of the screen.  
The setting range is +2 to -2.

### 4 Press ENTER.

A window for setting parameters appears instead of the VFP mode selection window.

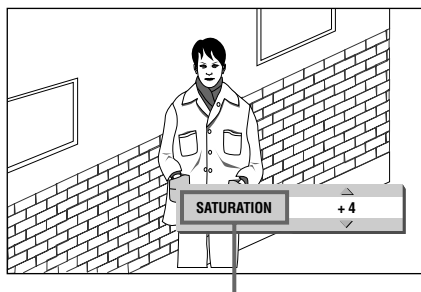

Selected parameter

### 5 Use ▲/▼ to adjust the level of the parameter.

The higher value enhances the effect.

### 6 Press ENTER.

The parameter is set and the VFP mode selection window appears again.

Repeat steps 3 to 6 if you want to set other parameters.

#### NOTES

- The number of setting steps depends on parameters.
- To dismiss the VFP mode selection window:  
Press VFP - PROGRESSIVE SCAN.
- The window for VFP mode selection and parameter setting disappears if no operation is made for about 10 seconds.
- The VFP function cannot be used during JPEG playback.

## To simulate surround sound [3D PHONIC]

Available :

Using the 3D PHONIC function, you can get a simulated surround effect from your stereo system.

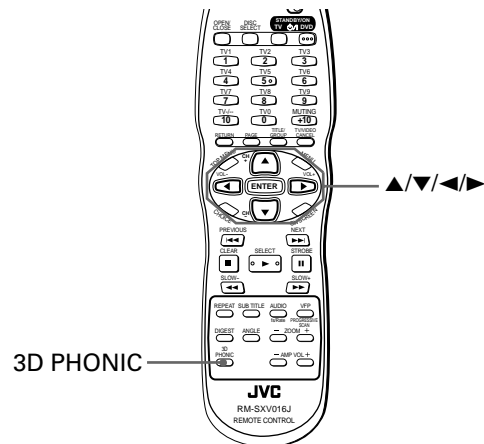

- During playback

#### 1 Press 3D PHONIC.

The 3D PHONIC window appears on the TV screen.

#### 2 Use ◀/▶ to select the desired mode.

Each time you press the button, the 3D PHONIC mode changes as follows:

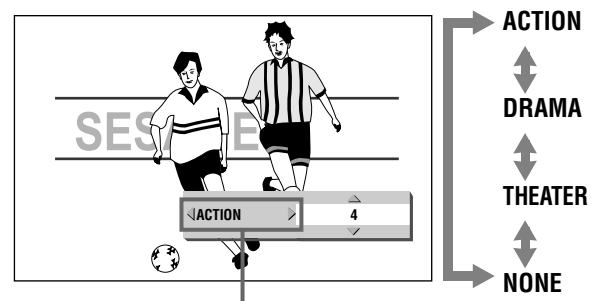

Selected effect mode

- **ACTION**  
Suitable for action movies and sports programs in which sounds dynamically move.
- **DRAMA**  
Natural and warm sound. You can enjoy movies in a relaxed mood.
- **THEATER**  
You can enjoy sound effects like in a major theater in Hollywood.

### 3 Press ▲/▼ to adjust the effect level.

You can select the effect level among "1" to "5."  
The higher value enhances the effect.

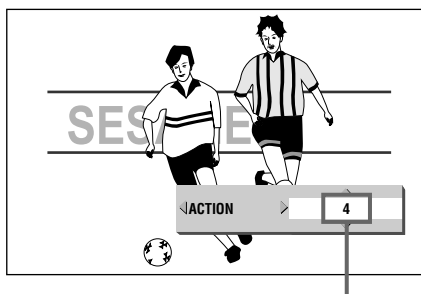

Effect level

#### NOTES

- To dismiss the 3D PHONIC window:  
Press 3D PHONIC.
- The 3D PHONIC window disappears if no operation is made for about 10 seconds.
- The 3D PHONIC function works correctly only when playing back a DVD VIDEO disc recorded with the Dolby Digital. With other sources, you cannot get any effect if you press the 3D PHONIC button.
- When playing back a DVD VIDEO disc recorded with the Dolby Digital that does not contain the rear signal, you cannot get a correct 3D PHONIC sound though you can change the 3D PHONIC setting.
- The 3D PHONIC function does not affect the Dolby Digital bitstream signal from the DIGITAL OUT jacks.
- When you set the 3D PHONIC function is active, the "ANALOG OUT" and "D. RANGE COMPRESSION" settings in the "AUDIO" preference display are disabled.

## Checking the sampling frequency and bit rate

Available : **DVD AUDIO** **DVD VIDEO** **Super VCD** **Video CD** **Audio CD**

You can check the sampling frequency and bit rate of digital audio during playback.

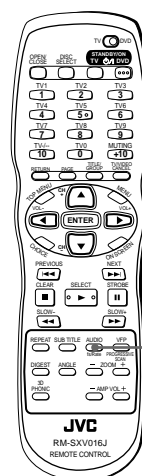

AUDIO-fs/Rate

- During playback

### 1 Press and hold down AUDIO-fs/Rate for a few seconds.

The sampling frequency and bit rate of the current digital audio are shown in the display window and are stayed on.

(Example for Audio CD)

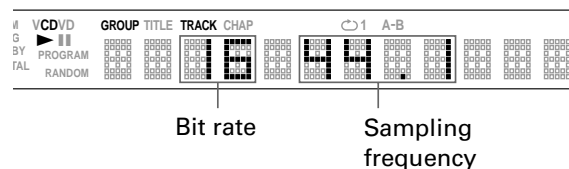

The sampling frequencies indicated are as follows: 44.1, 48.0, 88.2, 96.0, 176.4, and 192 (kHz). Note that any figure below the first decimal place is omitted in the display window.

#### NOTE

- With some discs, "NO INFO." may appear instead of the sampling frequency and bit rate.

# Menu bar functions

This section describes the functions you can perform via the menu bar.

The available menu bar functions differ depending on the disc type.

## To bring up the menu bar

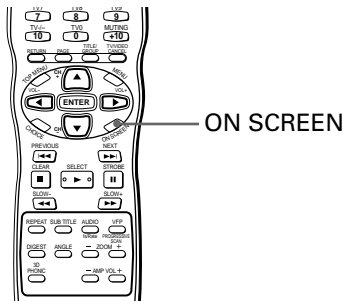

- When a disc is inserted

### 1 Press ON SCREEN.

The status bar, according to the disc type, appears on the TV screen.

See page 27 about the status bar.

(Example of the status bar for DVD VIDEO)



### 2 Press ON SCREEN again.

The appropriate menu bar, according to the disc type, appears together with the status bar. The menu bar includes some icons which indicate the associated functions.

(for DVD AUDIO)



(for DVD VIDEO)



(for SVCD)



(for Video CD)



(for Audio CD)

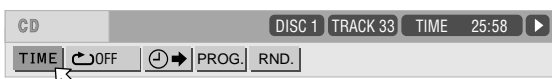

#### NOTE

- **To dismiss the menu bar (and status bar):**  
Press ON SCREEN.

## Basic operation procedure

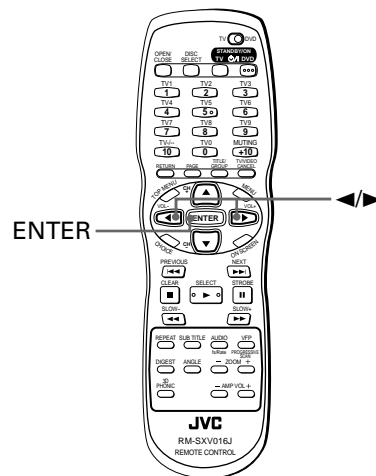

### 1 Use ◀▶ to select the icon you want to work with.

The selected icon is pointed by ↘.



### 2 Press ENTER.

With many icons, an appropriate pull-down window appears, however, there are some exceptions.

- See the following pages for details about each function.
- Note that some functions are not available during playback. (You cannot move ↘ to the associated icon when it is not available.)

#### NOTES

- When ⏸ appears on the TV screen:  
You cannot use the selected function because of disc contents.
- A mark or text on the menu icon for the function or mode currently selected is shown in blue.



## Menu bar functions for DVD AUDIO

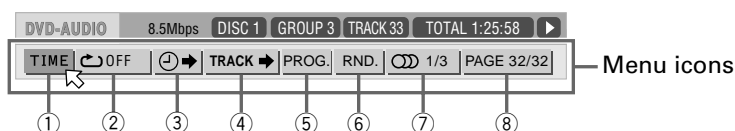

The following table shows the menu bar functions available for DVD AUDIO. Note that, in the description of the operation column, we assume the associated icon is selected.



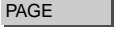

Selected Icon	Operation	Note
<p>① <b>TIME</b></p> <p><b>Time mode selection</b> (During playback only)</p> <p>Selects the time mode shown in the display window on the front panel and in the status bar.</p>	<p>Press ENTER to select the time mode among the following.</p> <p><b>TIME</b> → <b>REM</b> → <b>TOTAL</b> → <b>T.REM</b> → Return to initial</p> <ul style="list-style-type: none"> <li>• <b>TIME:</b> Current track elapsed time</li> <li>• <b>REM:</b> Current track remaining time</li> <li>• <b>TOTAL:</b> Current group elapsed time</li> <li>• <b>T.REM:</b> Current group remaining time</li> </ul>	<ul style="list-style-type: none"> <li>• If the disc has only one group and one track, "TOTAL" and "TIME" show the same value.</li> </ul>
<p>② <b>Repeat mode</b> (During playback only)</p> <p>Select the repeat mode.</p>	<p>1 Press ENTER to open the pull-down window.</p> <p>2 Use ▲/▼ to select the repeat mode among the following.</p> <p><b>TRACK</b> ↔ <b>GROUP</b> ↔ <b>ALL</b> ↔ <b>A-B</b> ↔ <b>OFF</b></p> <ul style="list-style-type: none"> <li>• <b>TRACK:</b> Current Track repeat</li> <li>• <b>GROUP:</b> Current group repeat</li> <li>• <b>ALL:</b> Repeats all the available discs</li> <li>• <b>A-B:</b> Repeats a desired part (A-B repeat)</li> </ul> <p>3 Press ENTER to make the selected repeat function active. (See pages 37 to 39 for details about repeat function.)</p>	<ul style="list-style-type: none"> <li>• If you select "OFF" during repeat playback, the unit continues playback without repeating.</li> <li>• For the subsequent operations for the A-B repeat, see page 38.</li> <li>• "A-B" is not shown in stop mode.</li> </ul>
<p>③ <b>Time search</b></p> <p>Specifies the elapsed time from the beginning of the current group, from which the unit starts playback.</p>	<p>1 Press ENTER to open the pull-down window.</p> <p>2 Use numeric buttons to enter a desired time.</p> <p>3 Press ENTER to play back from the specified time. (See page 31 for details about time search function.)</p>	_____
<p>④ <b>Track search</b></p> <p>Specifies a desired track to be played back from.</p>	<p>1 Press ENTER to open the pull-down window.</p> <p>2 Use numeric buttons to enter a desired track number.</p> <ul style="list-style-type: none"> <li>• For example of entering "12," press "1" then "2."</li> </ul> <p>3 Press ENTER to play back from the specified track.</p> <ul style="list-style-type: none"> <li>• <b>When the track number is incorrect:</b> Overwrite the incorrect number with the correct number.</li> </ul>	<ul style="list-style-type: none"> <li>• The "10" and "+10" buttons are not used in this function.</li> <li>• You can also locate a desired track directly by specifying the track number using the numeric buttons during playback. See page 25.</li> </ul>
<p>⑤ <b>Program</b> (While stopped only)</p> <p>Specifies the playback order of tracks.</p>	<p>1 Press ENTER to bring up the program table.</p> <p>2 Specify tracks in the desired order using the numeric buttons.</p> <p>3 Press ► to start program playback. (See page 35 for details about program playback.)</p>	_____
<p>⑥ <b>Random</b> (While stopped only)</p> <p>Activates random playback.</p>	<p>1 Press ENTER to activate random playback. (See page 36 for details about random playback.)</p>	_____

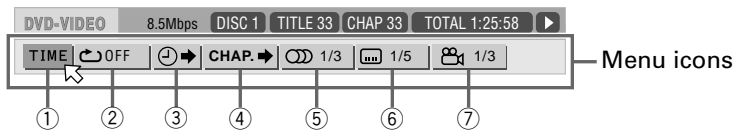

Selected Icon	Operation	Note
<p>⑦  <b>Audio selection</b> (During playback only) Selects the audio language or sound.</p>	<p>1 Press ENTER to open the pull-down window. 2 Use ▲/▼ to select a desired audio language or sound. <b>Example:</b> 1/3 ENGLISH ↔ 2/3 FRENCH ↔ 3/3 SPANISH 3 Press ENTER to play back with the selected audio. (See page 40 for details about audio selection.)</p>	_____
<p>⑧  <b>Page selection</b> (During playback only) Selects the page.</p>	<p>1 Press ENTER to open the pull-down window. 2 Use ▲/▼ to select a desired page number. 3 Press ENTER to play back with the selected page. (See page 33 for details about page selection.)</p>	_____

## Menu bar functions for DVD VIDEO



The following table shows the menu bar functions available for DVD VIDEO. Note that, in the description of the operation column, we assume the associated icon is selected.

Selected Icon	Operation	Note
<p>①  <b>Time mode selection</b> (During playback only) Selects the time mode shown in the display window on the front panel and in the status bar.</p>	<p>Press ENTER to select the time mode among the following. <b>TOTAL → T.REM → TIME → REM → Return to initial</b></p> <ul style="list-style-type: none"> <li>• <b>TOTAL:</b> Current title elapsed time</li> <li>• <b>T.REM:</b> Current title remaining time</li> <li>• <b>TIME:</b> Current chapter elapsed time</li> <li>• <b>REM:</b> Current chapter remaining time</li> </ul>	<ul style="list-style-type: none"> <li>• If the disc has only one title and one chapter, "TOTAL" and "TIME" show the same value.</li> </ul>
<p>②  <b>Repeat mode</b> (During playback only) Select the repeat mode.</p>	<p>1 Press ENTER to open the pull-down window. 2 Use ▲/▼ to select the repeat mode among the following. <b>CHAPTER ↔ TITLE ↔ ALL ↔ A-B ↔ OFF</b></p> <ul style="list-style-type: none"> <li>• <b>CHAPTER:</b> Current chapter repeat</li> <li>• <b>TITLE:</b> Current title repeat</li> <li>• <b>ALL:</b> Repeats all the available discs.</li> <li>• <b>A-B:</b> Repeats a desired part (A-B repeat)</li> </ul> <p>3 Press ENTER to make the selected repeat function active. (See pages 37 to 39 for details about repeat function.)</p>	<ul style="list-style-type: none"> <li>• If you select "OFF" during repeat playback, the unit continues playback without repeating.</li> <li>• For the subsequent operations for the A-B repeat, see page 38.</li> <li>• "A-B" is not shown in stop mode.</li> </ul>
<p>③  <b>Time search</b> Specifies the elapsed time from the beginning of the current title, from which the unit starts playback.</p>	<p>1 Press ENTER to open the pull-down window. 2 Use numeric buttons to enter a desired time. 3 Press ENTER to play back from the specified time. (See page 31 for details about time search function.)</p>	_____
<p>④  <b>Chapter search</b> (During playback only) Specifies a desired chapter to be played back from.</p>	<p>1 Press ENTER to open the pull-down window. 2 Use numeric buttons to enter a desired chapter number.</p> <ul style="list-style-type: none"> <li>• For example of entering "12", press "1" then "2".</li> </ul> <p>3 Press ENTER to play back from the specified chapter.</p> <ul style="list-style-type: none"> <li>• When the chapter number is incorrect: Overwrite the incorrect number with the correct number.</li> </ul>	<ul style="list-style-type: none"> <li>• The "10" and "+10" buttons are not used in this function.</li> <li>• You can also locate a desired chapter directly by specifying the chapter number using the numeric buttons during playback. See page 25.</li> </ul>



Selected Icon	Operation	Note
<p>⑤ </p> <p><b>Audio selection</b> (During playback only) Selects the audio language or sound.</p>	<p>1 Press ENTER to open the pull-down window. 2 Use ▲/▼ to select a desired audio language or sound. <b>Example:</b> 1/3 ENGLISH ↔ 2/3 FRENCH ↔ 3/3 SPANISH 3 Press ENTER to play back with the selected audio. (See page 40 for details about audio selection.)</p>	<ul style="list-style-type: none"> <li>For DVD VIDEO, the selected language may be abbreviated on the TV screen. See "Table of languages and their abbreviations" on page 62.</li> </ul>
<p>⑥ </p> <p><b>Subtitle selection</b> (During playback only) Selects the subtitle language.</p>	<p>1 Press ENTER to open the pull-down window. 2 Use ▲/▼ to select a desired subtitle language. <b>Example:</b> 1/3 ENGLISH ↔ 2/3 FRENCH ↔ 3/3 SPANISH ↔ -/3 OFF 3 Press ENTER to play back with the selected subtitle. (See page 39 for details about subtitle selection.)</p>	
<p>⑦ </p> <p><b>Angle selection</b> (during playback only) Selects a desired scene angle in the multi-angle part.</p>	<p>1 Press ENTER to open the pull-down window. 2 Use ▲/▼ to select a scene angle. <b>Example:</b> 1/3 ↔ 2/3 ↔ 3/3 3 Press ENTER to play back with the selected scene angle. (See page 41 for details about angle selection.)</p>	

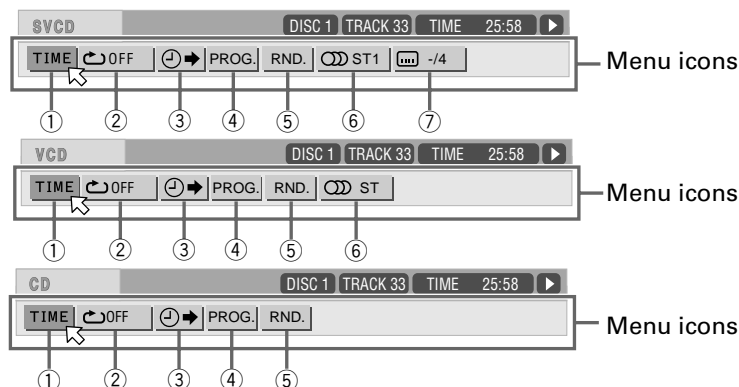



## Menu bar functions for SVCD/Video CD/Audio CD



The following table shows the menu bar functions available for SVCD/Video CD/Audio CD.

Note that, in the description of the operation column, we assume the associated icon is selected.

Selected Icon	Operation	Note
<p>① </p> <p><b>Time mode selection</b> Selects the time mode shown in the display window on the front panel and in the status bar.</p>	<p>Press ENTER to select the time mode among the following. <b>TIME</b> → <b>REM</b> → <b>TOTAL</b> → <b>T.REM</b> → Return to initial</p> <ul style="list-style-type: none"> <li><b>TIME:</b> Current track elapsed time</li> <li><b>REM:</b> Current track remaining time</li> <li><b>TOTAL:</b> Disc elapsed time</li> <li><b>T.REM:</b> Disc remaining time</li> </ul>	<ul style="list-style-type: none"> <li>When you select "REM" while stopped, you can change the track by pressing ◀◀ or ▶▶.</li> <li>During stopped, "REM" shows the recording time of the current track, while "T.REM" shows the total time of the disc.</li> </ul>
<p>② </p> <p><b>Repeat mode</b> Select the repeat mode. (During SVCD/Video CD playback only)</p>	<p>1 Press ENTER to open the pull-down window. 2 Use ▲/▼ to select the repeat mode among the following. <b>OFF</b> ↔ <b>TRACK</b> ↔ <b>DISC</b> ↔ <b>ALL</b> ↔ <b>A-B</b> ↔ <b>OFF</b></p> <ul style="list-style-type: none"> <li><b>TRACK:</b> Current track repeat</li> <li><b>DISC:</b> Repeats all tracks on the current disc.</li> <li><b>ALL:</b> Repeats all the available discs.</li> <li><b>A-B:</b> Repeats a desired part (A-B repeat)</li> </ul> <p>3 Press ENTER to make the selected repeat function active. (See pages 37 to 39 for details about repeat function.)</p>	<ul style="list-style-type: none"> <li>If you select "OFF" during repeat playback, the unit continues playback without repeating.</li> <li>For the subsequent operations for the A-B repeat, see page 38.</li> <li>"A-B" is not shown in stop mode.</li> </ul>

Selected Icon	Operation	Note
③  <b>Time search</b> (Except during SVCD/Video CD playback with PBC) Specifies the elapsed time from the beginning of the disc, from which the unit starts playback.	1 Press ENTER to open the pull-down window. 2 Use numeric buttons to enter a desired time. 3 Press ENTER to play back from the specified time. (See page 31 for details about time search function.)	<ul style="list-style-type: none"> <li>• This function cannot be used during program playback.</li> </ul>
④  <b>Program</b> (While stopped only) Specifies the playback order of tracks.	1 Press ENTER to bring up the program table. 2 Specify tracks in the desired order using the numeric buttons. 3 Press ► to start program playback. (See page 35 for details about program playback.)	<hr/>
⑤  <b>Random</b> (While stopped only) Activates random playback.	1 Press ENTER to activate random playback. (See page 36 for details about random playback.)	<hr/>
⑥  <b>Audio selection</b> (During SVCD/Video CD playback only) Selects the audio channel(s).	1 Press ENTER to open the pull-down window. 2 Use ▲/▼ to select a desired audio channel(s). 3 Press ENTER to play back with the selected audio channel(s). (See page 40 for details about audio selection.)	<hr/>
⑦  <b>Subtitle selection</b> (During SVCD playback only) Selects the subtitle.	1 Press ENTER to open the pull-down window. 2 Use ▲/▼ to select a desired subtitle. 3 Press ENTER to play back with the selected subtitle. (See page 39 for details about subtitle selection.)	<hr/>

# MP3 disc playback

The unit can play back MP3 files on a private CD-R/RW disc or commercial CD. We refer to a disc that contains MP3 file as an "MP3 disc" in this manual. Though available functions with MP3 discs are limited, operations for the available functions are similar to those with Audio CD discs. Note that, if a disc contains both of MP3 and JPEG files, you can only play back files of either type selected by the MP3/JPEG setting in the PICTURE preference display (see page 64).

## What is MP3?

"MP3" stands for "MPEG Audio Layer-3," and is the part of the MPEG standard. It can store high quality stereo audio using very little space by only saving the audible sounds and discarding the sounds your ears won't pick up. A CD can store up to around 10 hours of MP3 audio, which is 10 times as much as Audio CD.

### NOTE



Make sure that the TV - DVD switch on the remote control unit is set to "DVD" when using the ▲/▼/◀/▶ and numeric buttons for controlling the unit.

## About MP3 disc

On an MP3 disc, each material (song) is recorded on a file. Files are sometimes grouped into a folder by artist, album, category, etc. In addition, a folder can be a member of another folder, creating hierarchical folder layers. If you are familiar with a personal computer, you may easily understand the hierarchical file/folder construction of MP3 discs. This unit simplifies the hierarchical construction of a disc and manages files and folders by "Tracks" and "Groups" in the following manners.

- Each file is regarded as a Track.
- A folder which has one or more files (Tracks) is regarded as a Group.
- A folders' folder which does not manage any file directly is ignored.
- Files which do not belong to any folder are grouped into "Group 1."
- The unit recognizes up to 150 Tracks per Group, and up to 99 Groups per disc. It ignores those exceeding the maximum numbers and cannot play back them. If there is any type of files other than MP3 files in a folder. Those files are also counted down from the total number of 150.

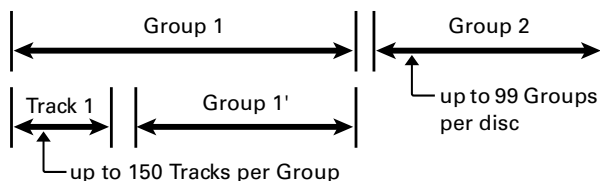

## NOTES for making a private MP3 disc using a CD-R/CD-RW disc:

- Select "ISO 9660" as the disc format.
- Finalize the disc after completing recording.
- We recommend to record a material at 44.1-kHz Fs and at the 128-kbps data transfer rate.

## NOTES

- Some discs may not be played back because of the disc characteristics or recording condition.
- Some tracks on an MP3 disc are skipped and may not be played back normally because of the disc configuration or characteristics determined by the writing (encoding) software and hardware used for recording. Such symptoms may occur regardless of whether using a disc you recorded or using a commercially available disc.
- The unit does not support "packet writing" discs.
- The unit does not support the ID3 tag.
- If the disc is recorded with multiple sessions, the unit supports up to five sessions.
- You cannot play back Tracks in the desired (programmed) or random order.
- The unit only can play back Tracks with any of the following file extensions; ".MP3", ".Mp3", ".mp3" and ".mP3".
- Time required for reading the disc contents differs with discs, depending on the numbers of Groups (folders) and Tracks (files) recorded, etc.
- While an MP3 disc is loaded, you cannot bring up any preference display (see pages 60 and 61).

## Operations

### Basic operations

Available : **MP3**

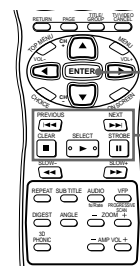

Basic control buttons

The following table shows basic functions of basic control buttons.

Buttons	Functions
	Starts playback while stopped.
	Starts playback while stopped or paused.
	Stops playback.
	Pauses playback.
	Skips back or forward a Track in the Group* during playback. Selects the previous or next Track in the Group* while stopped.

\*You can skip a Track across a Group.

- If you press ► during playback, or press ■ to stop playback followed by ►, the unit starts playback from the beginning of the current track.
- The ▲/▼ buttons work the same as the ◀/▶ buttons.

**NOTES**

- The current Group and Track numbers are shown on the display window in the following manner.



Current Group number      Current Track number      Current track elapsed time

- You cannot advance or reverse playback of an MP3 disc rapidly.
- You cannot see any other time information but the current track elapsed time.

## Selecting the desired Group and Track

Available :

When loading an MP3 disc, after the disc contents are read, the MP3 CONTROL display automatically appears on the TV screen.

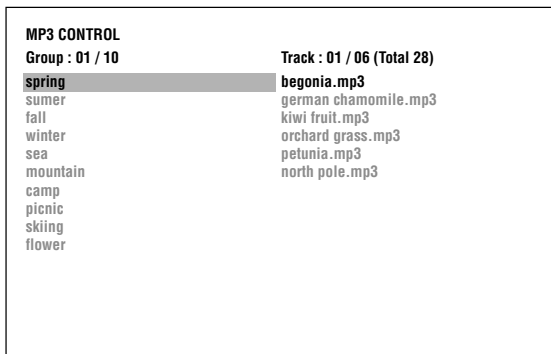

You can specify the desired Group/Track from the display by the following procedure.

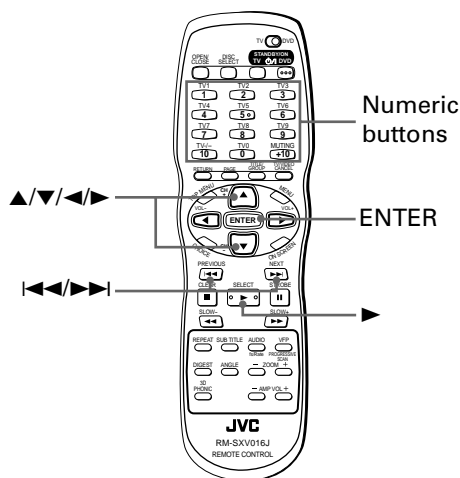

- When the MP3 CONTROL display is shown.

**1** Make sure that the black (cursor) bar is in the left (Group) column.

If it is in the right column, press ◀ to move it to the left column.

**2** Use ▲/▼ to move the bar to a desired Group.

On the right column, Tracks in the selected Group are shown.

When selecting a Group, Track 1 is initially selected (highlighted).

**3** Use ◀◀/▶▶ to select a desired Track, then press ENTER or ▶.

or

Use the numeric buttons to directly specify a desired Track number.

- To select a number between 1 and 10: Press the corresponding button for the number.
- To select a number higher than 10: Use the +10 button.

Examples:

To select 13: +10 → 3

To select 34: +10 → +10 → +10 → 4

To select 40: +10 → +10 → +10 → 10

To select 150: +10 (14 times) → 10

The unit starts playback from the selected Track. In the MP3 CONTROL display and the display window on the front panel, you can see the current Group and Track numbers, as well as Track elapsed time.

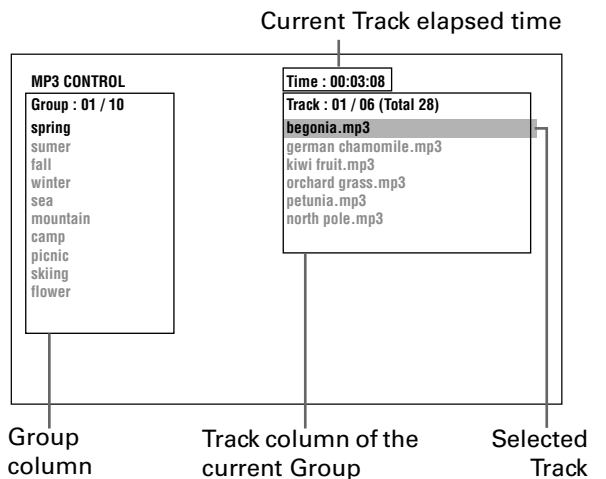

Hints

- You can also select a desired Track by pressing ▶ to move the black bar to the right (Track) column then using ▲/▼.

**NOTES**

- Up to 32 characters are displayed as a group or track name on the MP3 CONTROL display.
- If an MP3 file name includes any 2-byte character, the unit may not show the file name correctly.
- Only MP3 files are shown on the MP3 CONTROL display.
- The order of Groups/Tracks shown in the MP3 CONTROL display may differ from the order shown on your personal computer when you set the disc on your computer.
- If you remove the MP3 disc, the MP3 CONTROL display disappears.

## Direct selection

Available : **MP3**

You can select a desired Group directly by specifying the Group number.

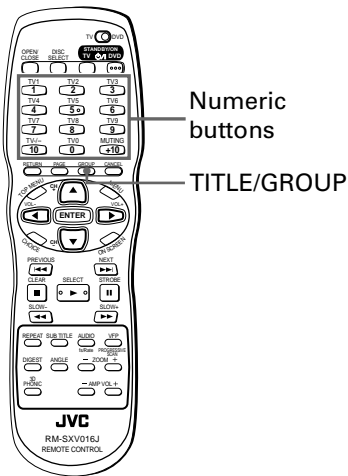

- During playback or while stopped

### 1 Press TITLE/GROUP.

"--" is shown in the Group display area of the display window.

(Example for the indication of window)

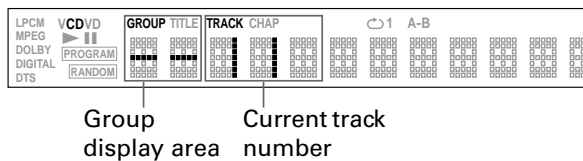

### 2 Use the numeric buttons to specify a desired Group number.

- To select a number between 1 and 10: Press the corresponding button for the number.
- To select a number higher than 10: Use the +10 button.

Examples:

- To select 13: +10 → 3
- To select 34: +10 → +10 → +10 → 4
- To select 40: +10 → +10 → +10 → 10

Specify the Group number within several seconds after pressing TITLE/GROUP (i.e. while the display window shows "--" for the Group number, instead of the current Group number).

The unit starts playback from Track 1 of the selected Group.

### 3 Use the numeric buttons to specify a desired Track number.

The unit starts playback from the specified Track. You can also use ◀◀/▶▶ or ▲/▼ for specifying a track, instead of the numeric buttons.

## Repeat playback

Available : **MP3**

You can repeat playback of the current Track, current Group or all MP3 files on the disc.

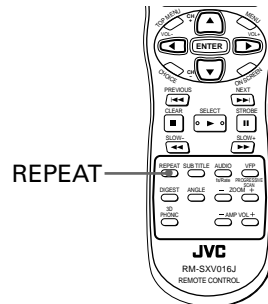

- During playback or while stopped

### 1 Press REPEAT.

Each time you press REPEAT, the repeat mode changes as follows. You can see the current mode via the display window as well as the MP3 CONTROL display.

If you press REPEAT while stopped, you need to press ENTER or ▶ to start repeat playback.

MP3 CONTROL display	Display Window	Function
REPEAT TRACK	↻ 1	Repeats the current Track.
REPEAT GROUP	↻	Repeats all Tracks in the current Group.
REPEAT DISC	↻	Repeats all Tracks on the disc.
REPEAT ALL	↻	Repeats all Tracks on the loaded discs.
No indication		The repeat mode is off.

(TV screen) Selected repeat mode

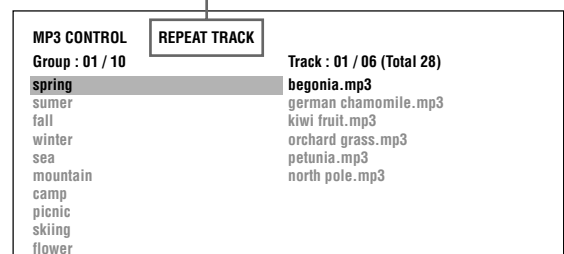

(Display window)



Repeat mode indicator

Press ■. Note that the repeat mode remains.

- **To quit repeat playback**

During playback, press REPEAT as many times until no repeat icon is shown on the display window. While stopped, press REPEAT as many times until repeat mode indication on the MP3 CONTROL display goes off.

## Checking the sampling frequency and bit rate

Available : **MP3**

You can check the sampling frequency and bit rate of digital audio during playback.

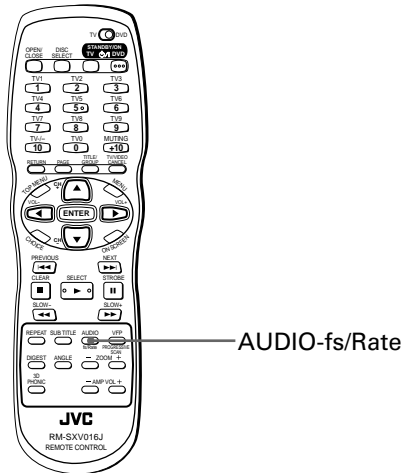

- During playback

**1** Press and hold down AUDIO-fs/Rate for a few seconds.

The sampling frequency and bit rate of the current digital audio are shown in the display window temporarily.

(Example)

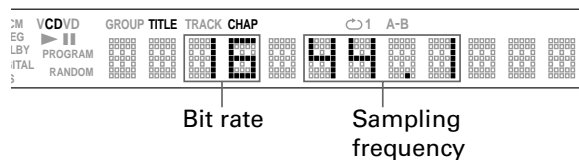

Note that any figure below the first decimal place is omitted in the display window.

### NOTE

- With some discs, "NO INFO." may appear instead of the sampling frequency and bit rate.



The unit can play back JPEG files on a private CD-R/RW disc. We refer to a disc that contains JPEG files as a "JPEG disc" in this manual.

Note that, if a disc contains both of MP3 and JPEG files, you can only play back files of either type selected by the MP3/JPEG setting in the PICTURE preference display (See page 64).

## What is JPEG?

"JPEG" is an abbreviation for the Joint Photographic Experts Group and is an image format that utilizes a compression technique.

There are three sub-types of the JPEG format as follows.

- baseline JPEG: used for digital cameras, web, etc.
- progressive JPEG: used for web
- lossless JPEG: an old type and rarely used now

The unit supports only the baseline JPEG type, therefore, it cannot display pictures of the other types (progressive and lossless). If a JPEG disc contains JPEG files of non-baseline type, the unit recognizes those files as JPEG files, the JPEG CONTROL display and the display window shows the information of the contents (file name, file number, etc.), but you cannot show the still pictures of those files (the TV screen appears only in black and "NON PLAYABLE FILE" is shown in the display window).

### NOTE



Make sure that the TV - DVD switch on the remote control unit is set to "DVD" when using the ▲/▼/◀/▶, numeric buttons for controlling the unit.

## About JPEG disc

On a JPEG disc, each material (still picture) is recorded on a file. Files may be grouped into a folder by category, etc. In addition, a folder can be a member of another folder, creating hierarchical folder layers. If you are familiar with a personal computer, you may easily understand the hierarchical file/folder construction of JPEG discs. This unit simplifies the hierarchical construction of a disc and manages folders by "Groups" in the following manners.

- A folder which has one or more files is regarded as a Group.
- A folders' folder which does not manage any file directly is ignored.
- Files which do not belong to any folder are grouped into "Group 1."
- The unit recognizes up to 150 files per Group, and up to 99 Groups per disc. It ignores those exceeding the maximum numbers and cannot play back them. If there is any type of files other than JPEG files in a folder. Those files are also counted down from the total number of 150.

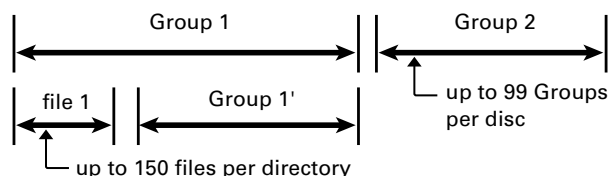

## NOTES for making a private JPEG disc using a CD-R/CD-RW disc:

- Select "ISO 9660" as the disc format.
- Finalize the disc after completing recording.
- We recommend to record a material at "640 x 480" resolution.
- The unit supports only the baseline JPEG type, therefore, it cannot display pictures of the other types (progressive and lossless). If a JPEG disc contains JPEG files of non-baseline type, the unit recognizes those files as JPEG files. the JPEG CONTROL display and the display window shows the information of the contents (file name, file number, etc.), but you cannot show the still pictures of those files (the TV screen appears only in black).

### NOTES

- The unit does not support "packet writing" discs.
- If the disc is recorded with multiple sessions, the unit supports up to five sessions.
- Some discs may not be played back, or take some times to open the whole picture because of the disc characteristics or recording condition.
- You cannot play back files in the desired (programmed) or random order.
- The screen saver function is activated while same picture is displayed for more than 5 minutes except during slide show playback (see page 57).
- The unit only can play back files with any of the following file extensions; ".jpg", ".jpeg", ".JPG", ".JPEG" and any uppercase and lowercase combination (such as ".Jpg").
- If a JPEG file name includes any 2-byte character, the unit may not show the file name correctly.
- When a picture resolution is more than "640 x 480", it takes some time to open the whole picture.
- Carry out an operation after opening the whole picture. The unit does not accept any operation (Stopping the unit, zooming in/out a picture etc.) while opening the picture.
- Time required for reading the disc contents differs with discs, depending on the numbers of Groups (folders) and files recorded, etc.
- If you play back a non-baseline JPEG file: The unit cannot display the still picture of the file. (The TV screen appears only in black.) In this case, other operations (such as stopping playback, selecting a file, etc.) are possible but may take a long time.
- While a JPEG disc is loaded, you cannot bring up any preference display (see pages 60 and 61).
- The available horizontal resolution of a JPEG file is up to 2,400 lines.

# Basic operations

## To see a desired picture

Available : **JPEG**

When loading a JPEG disc, after the disc contents are read, the JPEG CONTROL display automatically appears on the TV screen.

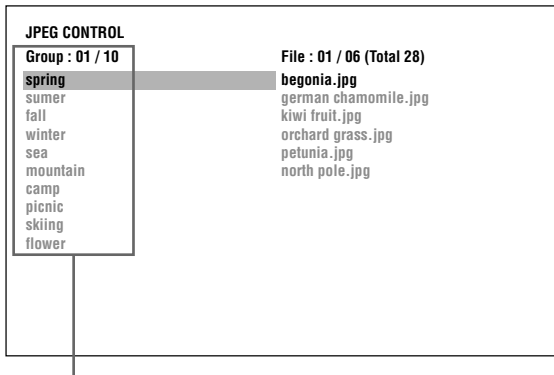

You can select a desired file for playback via this display.

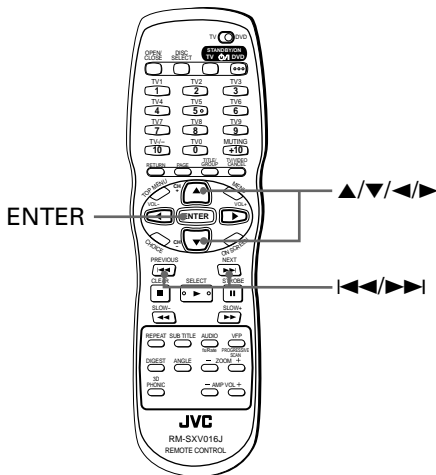

- When the JPEG CONTROL display is shown
  - Make sure that the black (cursor) bar is in the left (Group) column.  
If it is in the right column, press ◀ to move it to the left column.
  - Use ▲/▼ to move the bar to a desired Group.  
On the right column, files in the selected Group are shown.  
When selecting a Group, file 1 is initially selected (highlighted).

**3** Use ◀/▶ to select a desired file.

**4** Press ENTER.

The selected file (still picture) is shown on the TV. In the display window, you can see the current Group and file numbers.

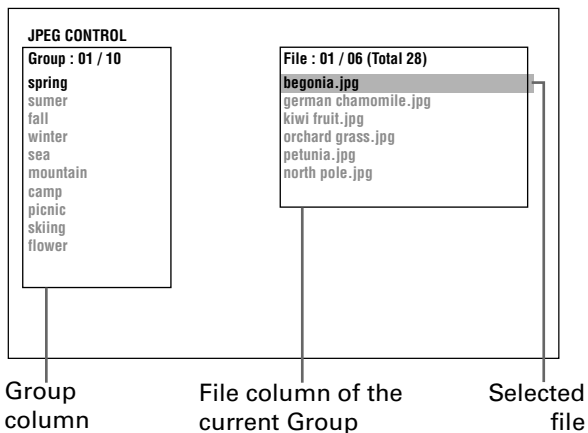

### Hints

- You can also select a desired file by pressing ▶ to move the black bar to the right (file) column then using ▲/▼.
- To return the black bar to the Group column, press ◀.
- To play back another picture:**  
Use ◀/▶ or ▲/▼ to select the desired picture. You can select a picture in another Group.
- To dismiss the picture:**  
Press ■ or MENU.  
The TV screen returns to the JPEG CONTROL display.  
Changing the disc dismisses the JPEG CONTROL display, and the opening screen appears.

### NOTES

- Up to 32 characters are displayed as a group or file name on the JPEG CONTROL display.
- The current Group and file number are also shown on the display window in the following manner.

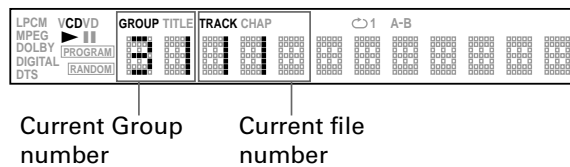

- Only JPEG files are shown on the display window.

## To zoom in/out the picture [ZOOM]

Available : **JPEG**

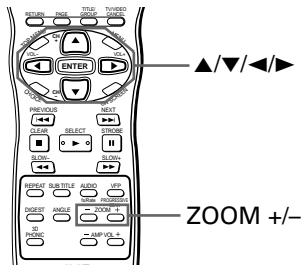

- While JPEG picture is shown on the TV screen

### 1 Press ZOOM + or -.

The unit zooms in by pressing ZOOM + or zooms out by pressing ZOOM - .  
 Each time you press ZOOM +, the magnification is doubled (up to x 1024).  
 Each time you press ZOOM -, the magnification is halved (down to x 1/8).

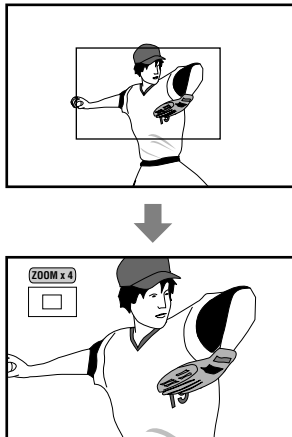

At the top-left of the screen, the information for the current magnification appears. While zoomed in, the indication for the zoomed-in position, which can be moved by operating the next step, appears together.

### 2 Use ▲/▼/◀/▶ to move the zoomed position.

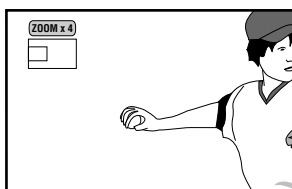

#### NOTES

- Even in the slide show mode, you can zoom in or out a picture while paused (see the next column).
- To return to normal screen:  
Press ENTER.
- While zoomed, the picture may look coarse.
- The zoom information on the screen will disappear if you do not operate the zoom function for five seconds.
- The indication for the zoomed-in position appears again when you press ZOOM +/-, or ▲/▼/◀/▶.

## To see pictures continuously [slide show mode]

You can see files (still pictures) one after another automatically in the slide show mode.  
 In this mode, each file (still picture) is shown on the TV for approximately 3 seconds and then automatically changed to the next file one after another.

## To play back pictures from the beginning of the disc

Available : **JPEG**

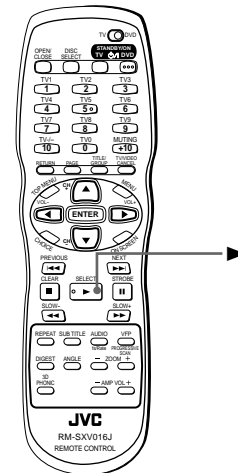

- After inserting a JPEG disc

### 1 Press ▶.

The slide show starts from the beginning of the disc.

#### NOTES

- To stop slide show playback (to dismiss the picture) in the middle of the slide show playback:  
Press ■ or MENU.  
The TV screen returns to the JPEG CONTROL display.  
Pressing ▶ resumes slide show playback from the last picture you opened.
- To keep showing a current picture during the slide show  
Press || or ENTER.  
The picture does not change to the next picture.  
Pressing ▶ resumes the slide show playback from the next picture.
- If a black screen appears continuously in the slide show playback:  
The file currently played may be non-baseline JPEG file. In this case, select a playable file (a baseline JPEG file) again (e.g., pressing ■ or MENU to open the JPEG CONTROL display, etc.)  
Note that it may take a long time to select another file.

## Selecting the start point of the slide show

Available : **JPEG**

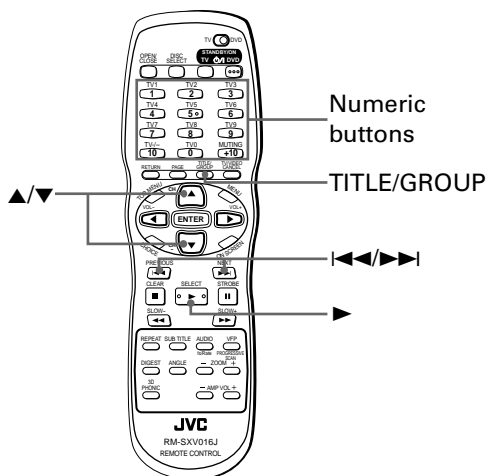

### From the JPEG CONTROL display

• While JPEG CONTROL display is shown

**1** Make sure that the black (cursor) bar is in the left (Group) column.

If it is in the right column, press ◀ to move it to the left column.

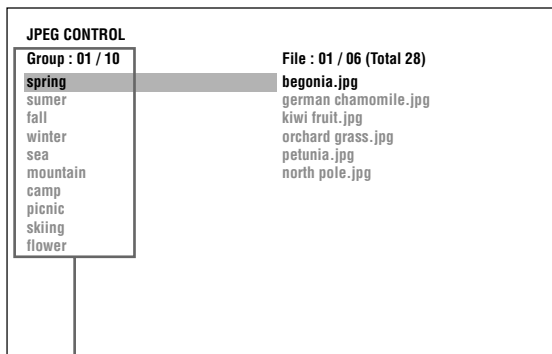

Group column

**2** Use ▲/▼ to move the bar to a desired Group.

On the right column, files in the selected Group are shown.

When selecting a Group, file 1 is initially selected (highlighted).

**3** Use ◀▶ to select a desired file.

**4** Press ▶.

The slide show starts from the specified file.

## Direct selection

• During playback or while stopped

**1** Press TITLE/GROUP.

"--" is shown in the Group display area of the display window.

(Example for the indication of display window)

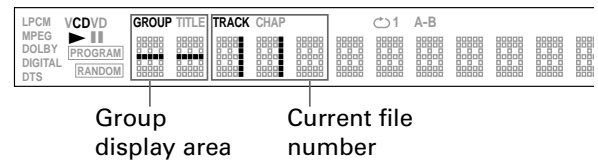

**2** Use the numeric buttons to specify a desired Group number.

- To select a number between 1 and 10:  
Press the corresponding button for the number.
- To select a number higher than 10:  
Use the +10 button.

Examples:

To select 13: +10 → 3

To select 34: +10 → +10 → +10 → 4

To select 40: +10 → +10 → +10 → 10

Specify the Group number within several seconds after pressing TITLE/GROUP (i.e. while the display window shows "--" for the Group number, instead of the current Group number).

**3** Use the numeric buttons to specify a desired file number.

You can specify the file number according to the order in the JPEG CONTROL display. You must specify a file number within 5 seconds after carrying out step 2.

The unit starts slide show playback from the specified file. If you do not specify a file number, the unit starts slide show playback from the first file in the Group.



- You can skip a file in the slide show by using ◀▶ or ▲/▼.
- You can select a file in the current group by using the numeric buttons.

### NOTES

- **To stop slide show playback (to dismiss the picture) in the middle of the slide show playback:**  
Press ■ or MENU.  
The TV screen returns to the JPEG CONTROL display. Pressing ▶ resumes slide show playback from the last picture you opened.
- **To keep showing a current picture during the slide show**  
Press || or ENTER.  
The picture does not change to the next picture. Pressing ▶ resumes the slide show playback from the next picture.
- **If a black screen appears continuously in the slide show playback:**  
The file currently played may be non-baseline JPEG file. In this case, select a playable file (a baseline JPEG file) again (e.g., pressing ■ or MENU to open the JPEG CONTROL display, etc.).  
Note that it may take a long time to select another file.

# Repeat function

Available : **JPEG**

In the slide show mode, you can repeat playback of JPEG files in a Group or on the disc.

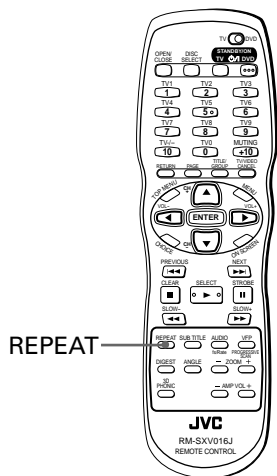

- To stop repeat playback**  
 Press **■**. Note that the repeat mode remains.
- To quit repeat playback**  
 During playback, press REPEAT as many times until no repeat icon is shown on the display window. While stopped, press REPEAT as many times until repeat mode indication on the JPEG CONTROL display goes off.

- While the JPEG CONTROL display is shown

## 1 Press REPEAT.

Pressing REPEAT switches the repeat mode. If you press REPEAT while stopped, you need to press **▶** to start repeat playback. The mode is shown in the display window by icons, while on the JPEG CONTROL display by mode names, as follows.

JPEG CONTROL display	Display Window	Function
REPEAT GROUP	↻	All files in the current Group are repeated.
REPEAT DISC		All files on the current disc are repeated.
REPEAT ALL		All files/tracks on the loaded discs are repeated.
No indication		The repeat mode is off.

(TV Screen)

Selected repeat mode

**JPEG CONTROL      REPEAT GROUP**

Group : 01 / 10      File : 01 / 06 (Total 28)

<p>spring</p> <p>summer</p> <p>fall</p> <p>winter</p> <p>sea</p> <p>mountain</p> <p>camp</p> <p>picnic</p> <p>skiing</p> <p>flower</p>	<p>begonia.jpg</p> <p>german chamomile.jpg</p> <p>kiwi fruit.jpg</p> <p>orchard grass.jpg</p> <p>petunia.jpg</p> <p>north pole.jpg</p>
--	--

(Display window)

LPCM	VCDVD	GROUP TITLE	TRACK	CHAP	↻	A-B
MPEG	<b>▶  </b>	PROGRAM	■■■■	■■■■	■■■■	■■■■
DOLBY	DIGITAL	RANDOM	■■■■	■■■■	■■■■	■■■■
DTS			■■■■	■■■■	■■■■	■■■■

Repeat mode indicator

# Changing the initial settings

## NOTE



Make sure that the TV - DVD switch on the remote control unit is set to "DVD" when using the ▲/▼/◀/▶ and numeric buttons for controlling the unit.

## Selecting preferences

This chapter refers to the settings which are already made when you purchase the unit. Read this section when you want to connect this machine to a wide-vision TV set or change the settings according to the environment you use this machine.

## About the Preference display

The preference display consists of the LANGUAGE, PICTURE, AUDIO, SPK.SETTING, and OTHERS setting displays, each having setting items.

### • LANGUAGE

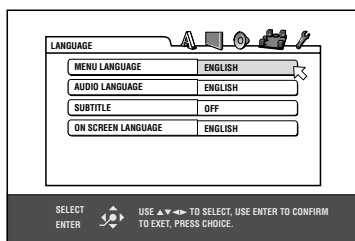

### • PICTURE

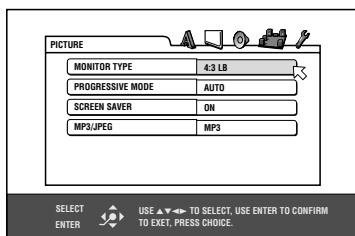

### • AUDIO

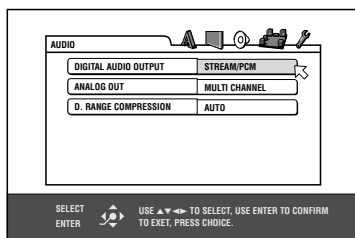

### • SPK.SETTING

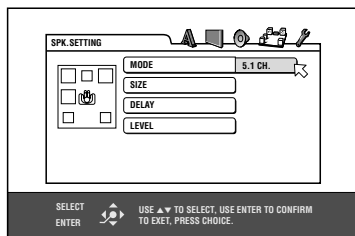

### • OTHERS

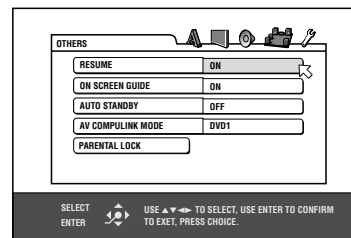

## How to set preferences

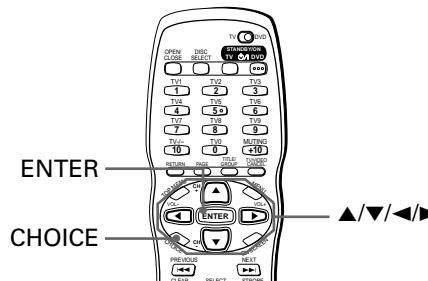

### • While stopped

#### 1 Press CHOICE.

One of the Preference on-screen displays appears on the TV screen.

You can see five icons at the top right of the on-screen display for the settings.

- : Setting menu for language
- : Setting menu for pictures
- : Setting menu for sound
- : Setting menu for speakers
- : Setting menu for the systems, etc.

#### 2 Use ◀/▶ to select the appropriate icon.

The appropriate display appears on the TV screen.

#### 3 Use ▲/▼ to move ▢ to the item you want to edit by.

The color of the selected item changes.

#### 4 Press ENTER.

The pull-down menu appears over the selected item.

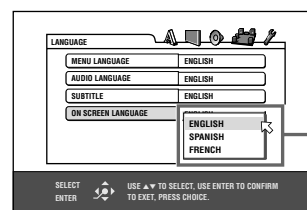

Selected item

#### 5 Use ▲/▼ to select from options and press ENTER.

The selected option is set.

- For details about each setting, see the following.

**NOTES**

- **To dismiss a preference display:**  
Press CHOICE.
- **While an MP3 or JPEG disc is loaded, you cannot bring up any preference display.**
- **When a preference display is shown on a wide TV screen, the upper and lower parts of the TV picture sometimes may be cut off. In such a case, adjust the picture size control of the TV.**

**LANGUAGE page**

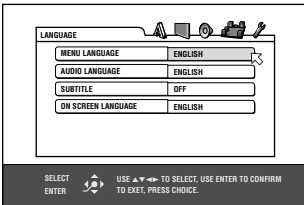

This page allows you to select languages concerning with DVD AUDIO/DVD VIDEO disc playback, as well as the on-screen display language of the unit.

**NOTES**

- **During playback, you can bring up any page of the preference displays, however, only "ON SCREEN LANGUAGE" can be set on the "LANGUAGE" page.**

Menu items	Setting options	Notes/examples
<p><b>MENU LANGUAGE</b> You can select the default menu language to be displayed if it is contained on a DVD AUDIO/DVD VIDEO disc.</p>	<p><b>ENGLISH ↔ SPANISH ↔ FRENCH ↔ CHINESE ↔ GERMAN ↔ ITALIAN ↔ JAPANESE ↔ language code from AA to ZU</b></p>	<ul style="list-style-type: none"> <li>• If the selected language is not recorded, the disc's default language is selected.</li> <li>• For details about language code, see "Table of languages and their abbreviations" (see page 62).</li> </ul>
<p><b>AUDIO LANGUAGE</b> You can select the default audio language to be played if it is contained on a DVD AUDIO/DVD VIDEO disc.</p>		
<p><b>SUBTITLE</b> You can select the default subtitle language to be displayed if it is contained on a DVD AUDIO/DVD VIDEO disc.</p>		
<p><b>ON SCREEN LANGUAGE</b> You can select the on-screen display language of the unit.</p>	<p><b>ENGLISH ↔ SPANISH ↔ FRENCH</b></p>	<p>English <input type="text" value="ON SCREEN LANGUAGE"/> <input type="text" value="ENGLISH"/></p> <p>Spanish <input type="text" value="IDIOMA EN PANTALLA"/> <input type="text" value="ESPAÑOL"/></p> <p>French <input type="text" value="LANGUE D'ECRAN"/> <input type="text" value="FRANCAIS"/></p> <ul style="list-style-type: none"> <li>• Some on-screen messages are shown in English regardless of the setting.</li> <li>• You cannot change the on-screen language shown on the MP3 and JPEG CONTROL displays.</li> </ul>

## Table of languages and their abbreviations

AA	Afar	FA	Persian	KM	Cambodian	OM	(Afan) Oromo	SU	Sundanese
AB	Abkhazian	FI	Finnish	KN	Kannada	OR	Oriya	SV	Swedish
AF	Afrikaans	FJ	Fiji	KO	Korean (KOR)	PA	Panjabi	SW	Swahili
AM	Ameharic	FO	Faroese	KS	Kashmiri	PL	Polish	TA	Tamil
AR	Arabic	FY	Frisian	KU	Kurdish	PS	Pashto, Pushto	TE	Telugu
AS	Assamese	GA	Irish	KY	Kirghiz	PT	Portuguese	TG	Tajik
AY	Aymara	GD	Scots Gaelic	LA	Latin	QU	Quechua	TH	Thai
AZ	Azerbaijani	GL	Galician	LN	Lingala	RM	Rhaeto-Romance	TI	Tigrinya
BA	Bashkir	GN	Guarani	LO	Laothian	RN	Kirundi	TK	Turkmen
BE	Byelorussian	GU	Gujarati	LT	Lithuanian	RO	Rumanian	TL	Tagalog
BG	Bulgarian	HA	Hausa	LV	Latvian, Lettish	RU	Russian	TN	Setswana
BH	Bihari	HI	Hindi	MG	Malagasy	RW	Kinyarwanda	TO	Tonga
BI	Bislama	HR	Croatian	MI	Maori	SA	Sanskrit	TR	Turkish
BN	Bengali, Bangla	HU	Hungarian	MK	Macedonian	SD	Sindhi	TS	Tsonga
BO	Tibetan	HY	Armenian	ML	Malayalam	SG	Sangho	TT	Tatar
BR	Breton	IA	Interlingua	MN	Mongolian	SH	Serbo-Croatian	TW	Twi
CA	Catalan	IE	Interlingue	MO	Moldavian	SI	Singhalese	UK	Ukrainian
CO	Corsican	IK	Inupiak	MR	Marathi	SK	Slovak	UR	Urdu
CS	Czech	IN	Indonesian	MS	Malay (MAY)	SL	Slovenian	UZ	Uzbek
CY	Welsh	IS	Icelandic	MT	Maltese	SM	Samoan	VI	Vietnamese
DA	Danish	IW	Hebrew	MY	Burmese	SN	Shona	VO	Volapuk
DZ	Bhutani	JI	Yiddish	NA	Nauru	SO	Somali	WO	Wolof
EL	Greek	JW	Javanese	NE	Nepali	SQ	Albanian	XH	Xhosa
EO	Esperanto	KA	Georgian	NL	Dutch	SR	Serbian	YO	Yoruba
ET	Estonian	KK	Kazakh	NO	Norwegian	SS	Siswati	ZU	Zulu
EU	Basque	KL	Greenlandic	OC	Occitan	ST	Sesotho		



# PICTURE page

This page allows you to select desired options concerning with a picture or monitor screen.

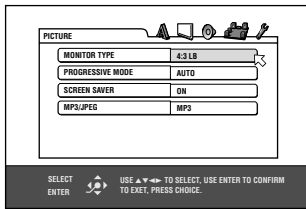

Menu items	Setting options	Notes/examples
<p><b>MONITOR TYPE</b></p> <p>You can select the monitor type to match your TV when you playback DVD VIDEO discs recorded for wide screen televisions.</p>	<ul style="list-style-type: none"> <li> <p><b>16:9 NORMAL (Wide Television screen)</b></p> <p>Should be selected when you connect the unit to a wide-screen (16:9) TV whose aspect ratio is fixed to 16:9 (the unit automatically adjusts the screen width of the output signal correctly when playing back a "4:3" source).</p> </li> <li> <p><b>16:9 AUTO (Wide Television screen)</b></p> <p>Should be selected when you connect a wide-screen (16:9) TV to the unit.</p> </li> <li> <p><b>4:3 LB (Letter Box Conversion)</b></p> <p>Should be selected when you connect a normal (4:3) TV to the unit.</p> <p>When playing back a DVD VIDEO disc recorded by the wide picture format, the picture is shown with black bars at the top and bottom.</p> </li> <li> <p><b>4:3 PS (Pan Scanning Conversion)</b></p> <p>Should be selected when you connect a normal (4:3) TV to the unit.</p> <p>When playing back a DVD VIDEO disc recorded by the wide picture format, the picture is automatically zoomed and the left and right sides are chopped off.</p> </li> </ul>	<div data-bbox="1058 528 1370 705" data-label="Image"> </div> <ul style="list-style-type: none"> <li> <p>If you play back a "4:3" DVD VIDEO source with the "16:9 NORMAL" mode, the picture character slightly changes due to the process for converting the picture width.</p> </li> </ul> <div data-bbox="1058 954 1295 1133" data-label="Image"> </div> <div data-bbox="1058 1211 1295 1391" data-label="Image"> </div> <ul style="list-style-type: none"> <li> <p>With some discs recorded by the wide picture format, the picture is shown in the 4:3 LB mode even if you select the 4:3 PS mode.</p> </li> </ul>
<p><b>PROGRESSIVE MODE</b></p> <p>When the unit is in the progressive scanning mode, you can select a desired mode from three options. Normally, set to "AUTO."</p>	<ul style="list-style-type: none"> <li> <p><b>VIDEO</b></p> <p>Suitable for playing back a video source disc.</p> </li> <li> <p><b>FILM</b></p> <p>Suitable for playing back a film or progressive source disc.</p> </li> <li> <p><b>AUTO</b></p> <p>Used to play back a disc containing both video and film source materials.</p> <p>The unit recognizes the picture type (film or video source) of the current disc according to the disc information.</p> </li> </ul>	<ul style="list-style-type: none"> <li> <p>When progressive scanning mode is active, the PROGRESSIVE indicator is lit. Note that the color of indication changes depending on this setting, source type and the unit's status. (See pages 7 and 8.)</p> </li> <li> <p>Some DVD VIDEO discs may not be played back correctly with the "AUTO" mode. If the playback picture is unclear or noisy with a particular DVD VIDEO disc, try to change the mode.</p> </li> </ul>

Menu items	Setting options	Notes/examples
<b>SCREEN SAVER</b> You can select the screen saver function ON or OFF. See page 19 for details about screen saver function.	<ul style="list-style-type: none"> <li>• <b>ON</b> The current picture gets dark.</li> </ul>	<ul style="list-style-type: none"> <li>• The screen saver function does not work for still images during DVD AUDIO playback.</li> </ul>
	<ul style="list-style-type: none"> <li>• <b>OFF</b> The screen saver function is off.</li> </ul>	
<b>MP3/JPEG</b> The unit can play back MP3 and JPEG files recorded on a CD-R/CD-RW disc, however, if a disc contains both of MP3 and JPEG files, you can only play back files of either type selected by this menu item.	<ul style="list-style-type: none"> <li>• <b>MP3</b> MP3 files can be played back if a disc contains both of MP3 and JPEG files.</li> </ul>	<ul style="list-style-type: none"> <li>• When a disc contains either MP3 or JPEG files, the unit can play back the files regardless of the setting.</li> </ul>
	<ul style="list-style-type: none"> <li>• <b>JPEG</b> JPEG files can be played back if a disc contains both of MP3 and JPEG files.</li> </ul>	

## AUDIO page

This page allows you to select desired options concerning with audio sound.

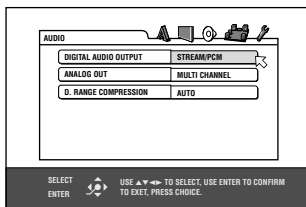

Menu items	Setting options	Notes/examples
<b>DIGITAL AUDIO OUTPUT</b> To connect the unit's digital output to an external device equipped with a digital input, this item must be set correctly. See the table below for details about the relation between the setting and output signals.	<ul style="list-style-type: none"> <li>• <b>PCM ONLY</b> Should be selected when you connect the DIGITAL OUT jacks of the unit to the linear PCM digital input of other audio equipment.</li> </ul>	<ul style="list-style-type: none"> <li>• When playing a DVD VIDEO or Audio CD disc with DTS, use a DTS decoder to get correct signals from your speakers.</li> <li>• With some DVD VIDEO discs that are not fully copy-protected, a 20 or 24 bit digital signal may be output.</li> </ul>
	<ul style="list-style-type: none"> <li>• <b>DOLBY DIGITAL/PCM</b> Should be selected when you connect the digital input of a Dolby Digital decoder or an amplifier with a built-in Dolby Digital decoder. When this option is selected, playing back a disc recorded by the DTS or MPEG Multichannel format outputs a linear PCM digital signal.</li> </ul>	
	<ul style="list-style-type: none"> <li>• <b>STREAM/PCM</b> Should be selected when you connect the digital input of an amplifier with a built-in DTS, MPEG Multichannel or Dolby Digital decoder, or the stand-alone unit of such a decoder.</li> </ul>	

### Digital output signal chart

Playback discs	Output		
	PCM ONLY	DOLBY DIGITAL/PCM	STREAM/PCM
DVD with 48/44.1 kHz, 16/20/24 bit linear PCM	48/44.1 kHz, 16 bit, stereo linear PCM		
DVD with 192/176.4/96/88.2 kHz, 16/22/24 bit linear PCM	No output		
DVD with DTS	48 kHz, 16 bit, stereo linear PCM		DTS bitstream
DVD with Dolby Digital	48 kHz, 16 bit, stereo linear PCM	Dolby Digital bitstream	
Audio CD/Video CD/SVCD	44.1 kHz, 16 bit, stereo linear PCM		
Audio CD with DTS	44.1 kHz, 16 bit, stereo linear PCM		DTS bitstream
CD-R/RW with MP3	Linear PCM		

Menu items	Setting options	Notes/examples
<p><b>ANALOG OUT</b> To play back a DVD VIDEO disc recorded with surround multichannel audio correctly, this setting must be properly made according to your audio system.</p>	<ul style="list-style-type: none"> <li>• <b>2-CH DOLBY SURROUND</b> Should be selected when you enjoy multichannel surround audio by connecting the unit's AUDIO OUT jacks to a surround decoder.</li> <li>• <b>2-CH STEREO</b> Should be selected when you enjoy conventional 2-channel stereo audio by connecting the unit's AUDIO OUT jacks to a stereo amplifier/receiver or television set, or when you duplicate audio of a DVD VIDEO disc recorded with surround audio to your MD, cassette, etc.</li> <li>• <b>MULTI CHANNEL</b> When you enjoy multichannel surround audio by connecting the unit's 5.1-channel audio outputs to an amplifier equipped with 5.1-channel inputs.</li> </ul>	<ul style="list-style-type: none"> <li>• This function does not work when the 3D PHONIC function is activated (see page 44).</li> <li>• "2-CH DOLBY SURROUND" and "2-CH STEREO" settings affect only the output signal from the AUDIO OUT jacks when playing back a DVD VIDEO disc recorded with surround multichannel audio.</li> <li>• Some DVD AUDIO discs prohibit the 2-channel down-mix. For such a disc, you cannot get the down-mixed signal even if you set "ANALOG OUT" to "2-DOLBY SURROUND" or "2-CH STEREO."</li> </ul>
<p><b>D. RANGE COMPRESSION</b> When enjoying a DVD VIDEO disc recorded with the Dolby Digital format at low or middle volume, this setting makes you hear sound comfortably.</p>	<ul style="list-style-type: none"> <li>• <b>AUTO</b> Audio is played back with the dynamic range compressed.</li> <li>• <b>ON</b> Audio is always played back with the dynamic range compressed.</li> </ul>	<ul style="list-style-type: none"> <li>• This function works only when playing back a disc recorded with Dolby Digital. The setting is not effective for other discs.</li> <li>• This function does not work when the 3D PHONIC function is activated (see page 44).</li> </ul>

# SPK.SETTING page

This setting allows you to select desired options concerning with the speakers.

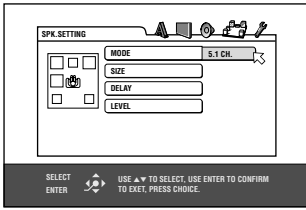

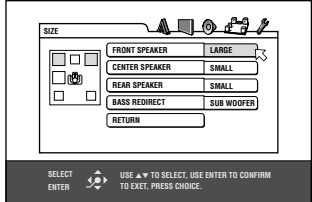
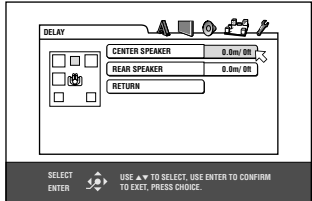
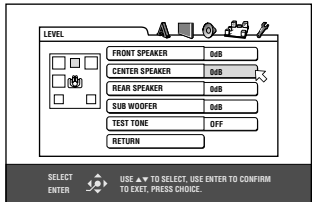
Menu items	Setting options	Notes/examples
<p><b>MODE</b> You can select the speaker configuration type according to your speaker systems. Normally, set to "5.1 CH."</p>	<ul style="list-style-type: none"> <li><b>5.1 CH.</b> When you connect to a 5.1-channel amplifier and use the front, rear, center and sub-woofer speakers.</li> <li><b>EXPERT</b> When you want to make fine tuning to match your speakers. The SIZE, DELAY, and LEVEL setting items are available.</li> </ul>	<ul style="list-style-type: none"> <li>When selecting "5.1 CH.," set "ANALOG OUT" to "MULTI CHANNEL" in the "AUDIO" preference display (see page 65).</li> <li>The Dolby Digital LEF (Low Frequency Effect) signal is always fed from the SUBWOOFER jack on the rear panel of the unit regardless of speaker setting.</li> <li>If you connect the unit's digital output to an external Dolby Digital or DTS decoder (and set "DIGITAL AUDIO OUTPUT" to "STREAM/PCM" in the "AUDIO" preference display), the speaker settings shown left is not effective. Make the speaker settings of the external decoder properly.</li> </ul>
<p><b>SIZE</b> You can set the speaker sizes according to your speakers.</p>	<p>See page 68 for details about the speaker size setting.</p>	<p>(SIZE display)</p>  <ul style="list-style-type: none"> <li>When playing back a DVD AUDIO disc with either [CENTER SPEAKER] or [REAR SPEAKER] set to [NONE], their audio does not output from the front speakers.</li> </ul>
<p><b>DELAY</b> You can set the speaker delay time according to your speakers.</p>	<p>See page 68 for details about the speaker delay time setting.</p>	<p>(DELAY display)</p> 
<p><b>LEVEL</b> You can set the speaker output level according to your speakers.</p>	<p>See page 69 for details about the speaker output level setting.</p>	<p>(LEVEL display)</p> 

Changing the initial settings

# OTHERS page

This page allows you to select desired options concerning with the system.

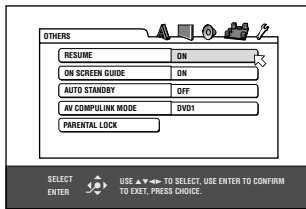

Menu items	Setting options	Notes/examples
<p><b>RESUME</b> You can select the resume playback mode.</p>	<ul style="list-style-type: none"> <li><b>ON</b> The unit can resume playback of the disc from the position you interrupted playback last time if it is still on the disc tray.</li> <li><b>OFF</b> The resume function is not active.</li> <li><b>DISC RESUME</b> The unit can resume playback of last 30 discs (the unit keeps memory positions even if a disc is removed from the disc tray).</li> </ul>	<ul style="list-style-type: none"> <li>See page 23 for details about resume playback function.</li> </ul>
<p><b>ON SCREEN GUIDE</b> The unit can display "on-screen guide" icons or characters on the picture, which show what is happening to the disc or the unit.</p>	<ul style="list-style-type: none"> <li><b>ON</b> The on-screen guide will be displayed.</li> <li><b>OFF</b> The on-screen guide will not be displayed.</li> </ul>	<ul style="list-style-type: none"> <li>See page 19 about on-screen guide icons.</li> <li>Examples of "on-screen guide" icons or characters: </li> </ul>
<p><b>AUTO STANDBY</b> When the unit is stopped for more than 30 minutes or 60 minutes, the unit enters standby mode automatically.</p>	<p>60 ↔ 30 ↔ OFF</p>	<hr/>
<p><b>AV COMPLINK MODE</b> If you use the AV COMPU LINK system, you must set this item correctly.</p>	<p>DVD 1 ↔ DVD 2 ↔ DVD 3</p>	<ul style="list-style-type: none"> <li>See page 75 for details about AV COMPU LINK function.</li> </ul>
<p><b>PARENTAL LOCK</b> When selecting this option, pressing ENTER on the remote control unit brings up the "PARENTAL LOCK" display shown right, in which you can restrict playback of DVD VIDEO discs for children.</p>	<p>See page 70 for details about the Parental Lock setting.</p>	<p>(PARENTAL LOCK display)</p>

# Making fine tuning for your speakers

You can make fine tuning to match your speaker system. This adjustment is available only when "ANALOG OUT" is set to "MULTI CHANNEL" in the "AUDIO" preference display and "MODE" is set to "EXPERT" in the "SPK.SETTING" preference display.

## To set the speaker sizes

You can set the speaker sizes according to your speakers.

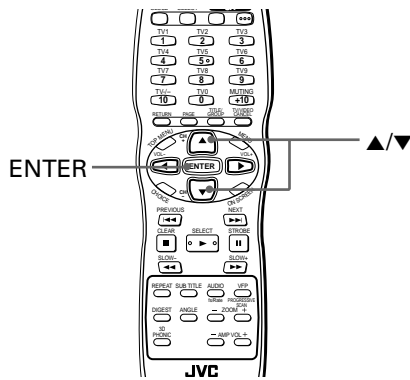

- While the "SPK.SETTING" page of the preference display is shown

1 Use ▲/▼ to move to [SIZE] and press ENTER.

The SIZE display page appears on the TV screen. points to [FRONT SPEAKER]. See page 60 for details about how to bring up the "SPK.SETTING" page.

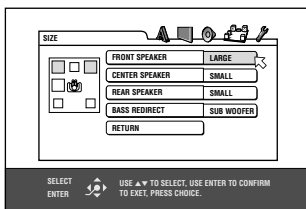

2 Use ▲/▼ to select the speaker to be set and press ENTER.

FRONT SPEAKER: Front speakers  
 CENTER SPEAKER: Center speaker  
 REAR SPEAKER: Rear speakers

3 Use ▲/▼ to select the size and press ENTER.

LARGE: Large speaker(s) which can fully reproduce the low-frequency range.  
 SMALL: Small speaker(s) which cannot fully reproduce the low-frequency range.  
 NONE: No speaker(s) connected. This option is only for "CENTER SPEAKER" and "REAR SPEAKER."

4 Repeat steps 2 and 3 if you set other speakers.

- To return to the "SPK.SETTING" page  
 Use ▲/▼ to move to [RETURN] and press ENTER.

### NOTES

- If you set the "FRONT SPEAKER" to "SMALL," you cannot set the other speakers to "LARGE."
- When playing back a DVD AUDIO disc with either [CENTER SPEAKER] or [REAR SPEAKER] set to [NONE], their audio does not output from the front speakers.

## BASS REDIRECT function

When you use the small speakers which do not fully reproduce the low-frequency range, you can boost up the low-frequency signal of the subwoofer or front speakers.

- 1 Use ▲/▼ to select [BASS REDIRECT] and press ENTER.
- 2 Use ▲/▼ to select [SUB WOOFER] or [FRONT L/R] and press ENTER.

SUB WOOFER: The low-frequency signal fed from the subwoofer output is boosted up.

FRONT L/R: The low-frequency signals fed from the front speaker outputs are boosted up.

The "BASS REDIRECT" setting is effective only when at least any one of the speaker sizes is set to "SMALL." If none of them is set to "SMALL," this setting is no activated.

("NONE" appears in the setting field.)



Please note that the "FRONT L/R" setting is effective only when playing back a Dolby Digital encoded DVD VIDEO disc. If the front speaker size is set to "SMALL," the "BASS REDIRECT" setting is fixed to "SUB WOOFER."

## To set the delay time

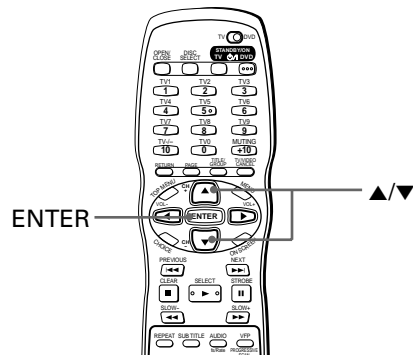
You can adjust the delay time of each speaker. Selecting each speaker distance, which is on the basis of the distance between the front speakers and the listening position, sets an appropriate delay time. Check that what the distance to each speaker is and set distance values following the procedure.



- While the "SPK.SETTING" page of the preference display is shown

- 1 Use ▲/▼ to move  to [DELAY] and press ENTER.  
The DELAY display page appears on the TV screen.  points to [CENTER SPEAKER].  
See page 60 for details about how to bring up the "SPK.SETTING" page.

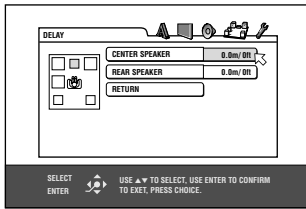

- 2 Use ▲/▼ to select the speaker to be set and press ENTER.  
CENTER SPEAKER: Center speaker  
REAR SPEAKER: Rear speakers
  - 3 Use ▲/▼ to select the delay time and press ENTER.  
When you select "CENTER SPEAKER," you can select the delay time from "0.0m/0ft" to "1.5m/5ft" in 1ft units.  
When you select "REAR SPEAKER," you can select the delay time from "0.0m/0ft" to "4.5m/15ft" in 1ft units.
  - 4 Repeat steps 2 and 3 if you set other speakers.
- To return to the "SPK. SETTING" page  
Use ▲/▼ to move  to [RETURN] and press ENTER.

**NOTE**



- For the speaker(s) whose size is set to "NONE," the delay time cannot be set.

**To set the speaker level**

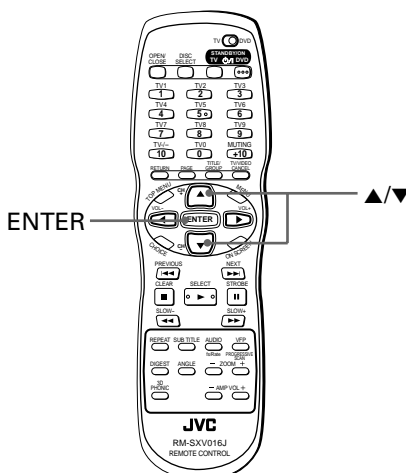
You can adjust the output level of each speaker.



- While the "SPK.SETTING" page of the preference display is shown

- 1 Use ▲/▼ to move  to [LEVEL] and press ENTER.  
The LEVEL display page appears on the TV screen.  points to [CENTER SPEAKER].  
See page 60 for details about how to bring up the "SPK.SETTING" page.

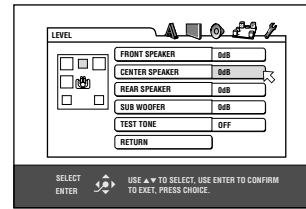

- 2 Use ▲/▼ to select the speaker to be set and press ENTER.  
FRONT SPEAKER: Front speakers (This item cannot be selected. The level is fixed to 0dB.)  
CENTER SPEAKER: Center speaker  
REAR SPEAKER: Rear speakers  
SUB WOOFER: Subwoofer speaker
  - 3 Use ▲/▼ to set the level and press ENTER.  
When you select "CENTER SPEAKER," "REAR SPEAKER" or "SUB WOOFER," you can select the level from -6 to 6dB in 1dB units.
  - 4 Repeat steps 2 and 3 if you set other speakers.
- To return to the "SPK.SETTING" page  
Use ▲/▼ to move  to [RETURN] and press ENTER.

**NOTE**

- For the speaker(s) whose size is set to "NONE," the speaker level cannot be set.

**To generate test tone signals**

You can check the level setting by monitoring the test tone.

- 1 Use ▲/▼ to select [TEST TONE] and press ENTER.
- 2 Use ▲/▼ to select [ON] and press ENTER.  
The test tone will be generated when you select the speaker(s) in the "LEVEL" display.

## Limiting playback by children

This function restricts playback of DVD VIDEO discs which contain violent (and other) scenes according to the level set by the user. For example, if a movie which includes violent scenes supports the parental lock feature, such scenes which you do not want to let children view can be cut or replaced with other scenes. When selecting "PARENTAL LOCK" in the "OTHERS" page of the preference display (see page 67), pressing ENTER on the remote control unit brings up the PARENTAL LOCK sub-page shown below, in which you can make setting for limiting playback.

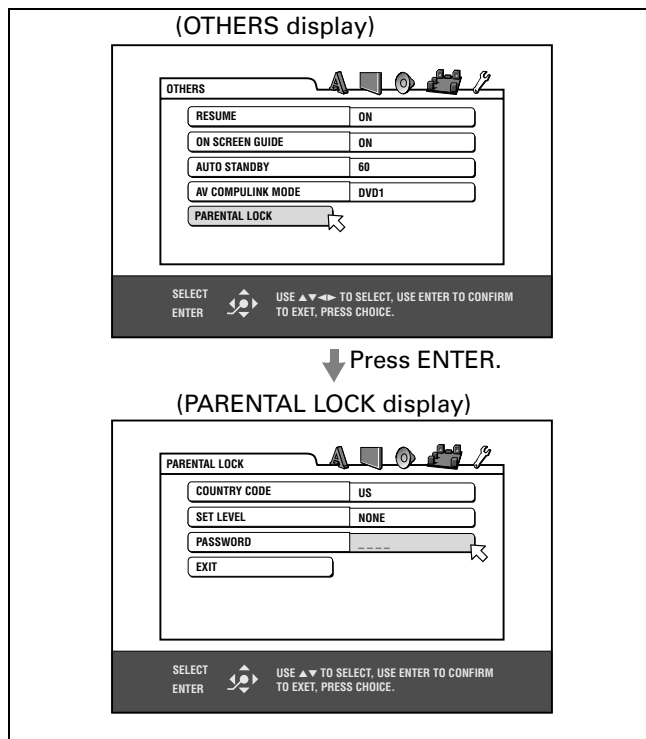

## To set Parental Lock for the first time [PARENTAL LOCK]

Available :

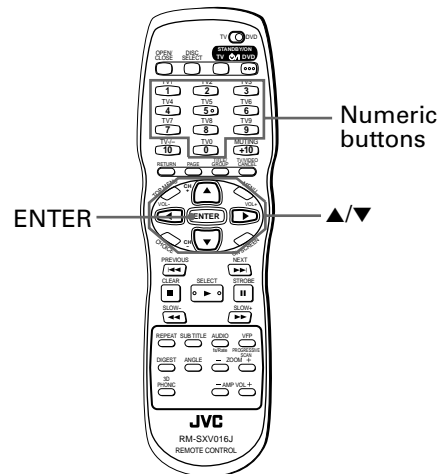

- While the "OTHERS" page of the preference display is shown

1 Use ▲/▼ to move to [PARENTAL LOCK] and press ENTER.

The Parental Lock on-screen display appears on the TV screen.

points to [COUNTRY CODE].

See page 60 for details about how to bring up the "OTHERS" page.

2 While points to [COUNTRY CODE], press ENTER to bring up the pull-down menu.

3 Use ▲/▼ to select the country code.

The country code whose standards were applied to rate the DVD VIDEO disc should be selected.

See "Appendix A: Country/Area code list for Parental Lock" on page 80.

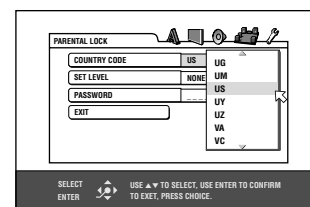

4 Press ENTER.

moves to [SET LEVEL].



- 5 While  points to [SET LEVEL], press ENTER to bring up the pull-down menu.

In the pull-down menu, "NONE" and level "1" to "8" are available.

"NONE" does not restrict playback. Level "1" is the strictest level. Discs rated higher than the selected level are restricted.

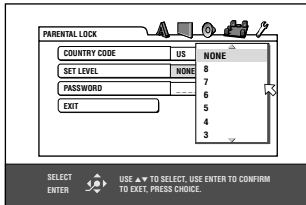

- 6 Use  to select a desired parental lock level, then press ENTER.

 moves to [PASSWORD].

- 7 Enter your 4-digit password using the numeric buttons (0 to 9).

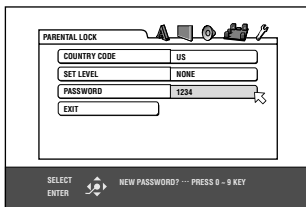

- 8 Press ENTER.

The setting is set.

 moves to [EXIT].

Pressing ENTER again returns to the "OTHERS" page of the preference display.

### Hints

- If you enter an undesired password in step 7, reenter the password before pressing ENTER.

## To change the settings [PARENTAL LOCK]



English

Available : 

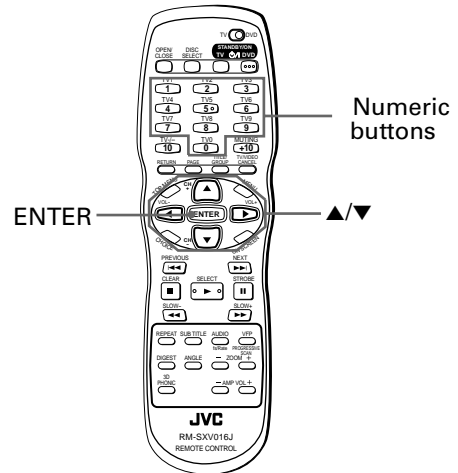
You can change the Parental Lock settings later.



- While the "OTHERS" page of the preference display is shown

- 1 Use  to move  to [PARENTAL LOCK] and press ENTER.

The Parental Lock on-screen display appears on the TV screen.

 points to [PASSWORD].

See page 60 for details about how to bring up the "OTHERS" page.

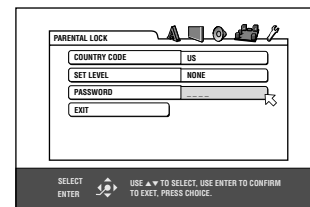



- 2 Enter your current 4-digit password using the numeric buttons (0 to 9) and press ENTER.

 moves to [COUNTRY CODE] if you enter the correct password.

If you enter the wrong password, "WRONG! RETRY..." appears on the TV screen, and you cannot go to the next step.

### NOTES

- If you enter the wrong password more than three times in step 2 above,  moves to [EXIT] automatically and  does not work.
- If you forget your password in step 2  
Enter "8888" The current password is deleted and you can set a new password.

**3** Press ENTER to bring up the pull-down menu.

The country code whose standards were applied to rate the DVD VIDEO disc should be selected. See "Appendix A: Country/Area code list for Parental Lock" on page 80. Note that if you change the country code, you must reselect the Parental Lock level.

**4** Press ENTER.

↵ moves to [SET LEVEL].

**5** Press ENTER to bring up the pull-down menu.

In the pull-down menu, "NONE" and level "1" to "8" are available. "NONE" does not restrict playback. Level "1" is the strictest level. Discs rated higher than the selected level are restricted.

**6** Use ▲/▼ to select a desired parental lock level, then press ENTER.

↵ moves to [PASSWORD].

**7** Enter a 4-digit password using the numeric buttons (0 to 9).

The password entered in the above step becomes the new password. If you do not change the password, enter the same password as in the step 2. Even if you want to change only the country code and/or parental level, do not forget to enter the password after changing the country code and/or parental level. Otherwise, the new country code and/or parental level will not become effective.

**8** Press ENTER.

↵ moves to [EXIT].

Pressing ENTER again returns to the "OTHERS" page of the preference display.

## To temporarily release the Parental Lock [PARENTAL LOCK]

Available : 

When you set the parental level strictly, some discs may not be played back at all. When you insert such a disc and try to play it, the following Parental Lock on-screen display appears on the TV screen, asking you whether you want the Parental Lock to be temporarily released or not.

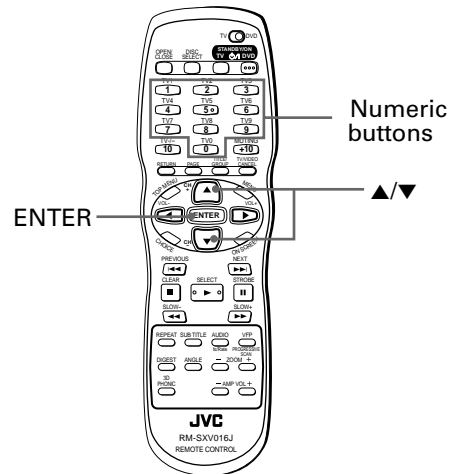

**1** Use ▲/▼ to move ↵ to [TEMPORARY RELEASE], then press ENTER.

↵ moves to the [PASSWORD].

When selecting [NOT RELEASE], press ▲ OPEN/CLOSE to remove the disc.

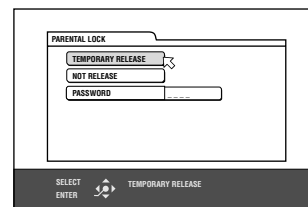

**2** Enter your 4-digit password using the numeric buttons (0 to 9).

The Parental Lock is released, and the unit starts playback.

If you enter the wrong password, "WRONG! RETRY..." appears on the TV screen.

Enter the correct password.

**3** Press ENTER.

**NOTE**

- When you enter the wrong password more than three times in step 2 above, ↵ moves to [NOT RELEASE] automatically and ▲/▼ does not work. In such cases, press ENTER.

## Names of parts and controls

Refer to the corresponding pages indicated in ( ) for details.

### Front panel

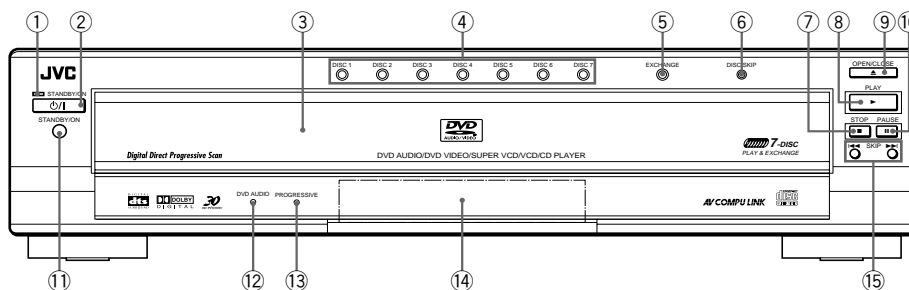

- ① STANDBY/ON indicator (11, 14)
- ② STANDBY/ON  $\text{\textcircled{I}}$  button (14)
- ③ Disc tray carousel (17, 22, 23)
- ④ DISC 1-7 buttons/indicators (14, 17, 19)
- ⑤ EXCHANGE button/indicator (17, 20)
- ⑥ DISC SKIP button (17, 20)
- ⑦ ■ STOP button (20, 22, 51)
- ⑧ ► PLAY button (19, 23)
- ⑨ ▲ OPEN/CLOSE button (17, 22, 23)
- ⑩ || PAUSE button (20, 26)
- ⑪ Remote sensor (12)
- ⑫ DVD AUDIO indicator (17)
- ⑬ PROGRESSIVE indicator (7, 8, 63)
- ⑭ Display windows (see the illustration below)
- ⑮ ◀◀/▶▶ SKIP buttons (24, 26)

### Display window

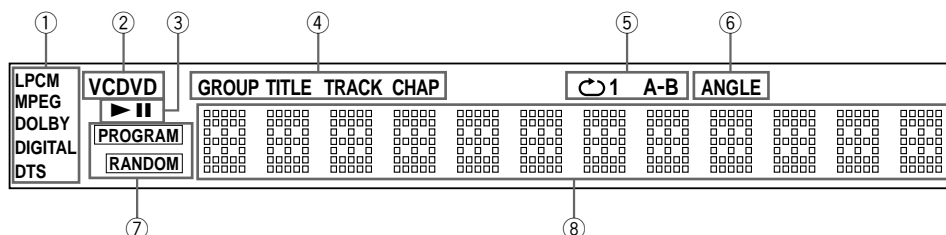

- ① Audio format indicators
- ② Disc indicator
- ③ ► (play)/|| (pause) indicators
- ④ Group/title/track/chapter indicators
- ⑤ Repeat mode indicators (37, 53, 59)
- ⑥ ANGLE indicator
- ⑦ PROGRAM/RANDOM indicators (35, 36)
- ⑧ Multi-information window

### Rear panel

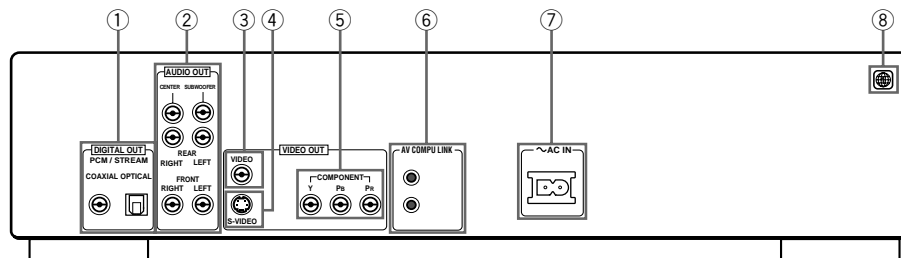

- ① DIGITAL OUT jacks (OPTICAL/COAXIAL) (10)
- ② AUDIO OUT jacks (FRONT RIGHT/FRONT LEFT/SUBWOOFER/CENTER/REAR RIGHT/REAR LEFT) (6, 7, 9, 10)
- ③ VIDEO OUT - VIDEO jack (6)
- ④ VIDEO OUT - S-VIDEO jack (6)
- ⑤ VIDEO OUT - COMPONENT jacks (Y/P<sub>B</sub>/P<sub>R</sub>) (7)
- ⑥ AV COMPU LINK jacks (75)
- ⑦ ~ AC IN connector (11)
- ⑧ Region code label (4)

Additional information

## Remote control unit

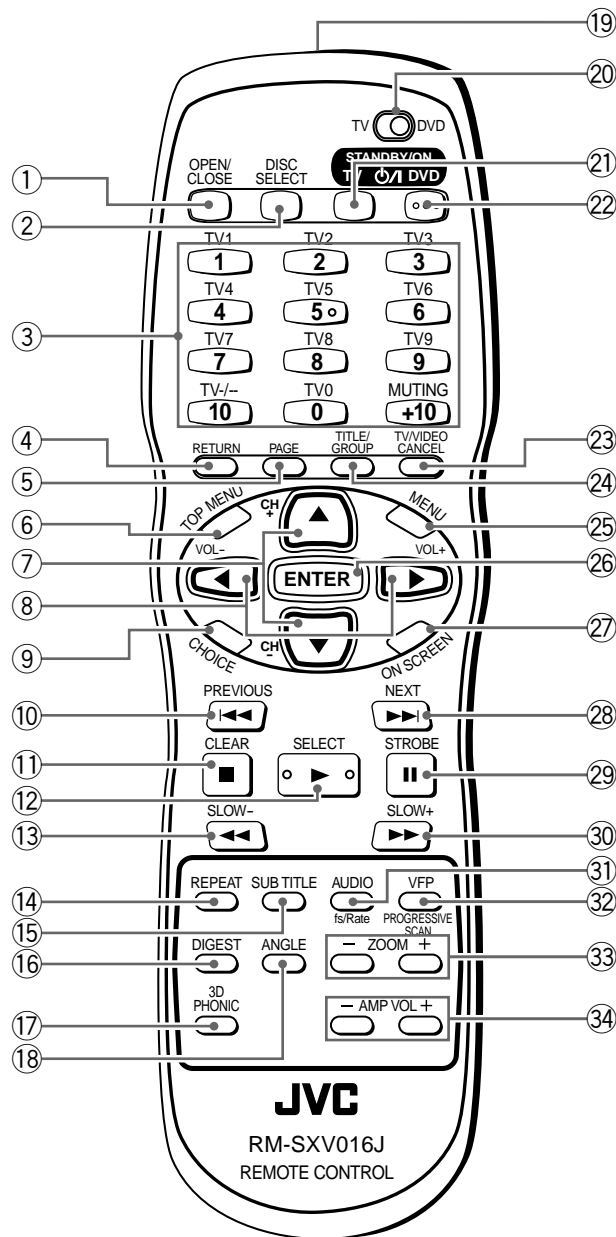

- |  |  |
|--|--|
| <ul style="list-style-type: none"> <li>① OPEN/CLOSE button (17, 18, 22, 23)</li> <li>② DISC SELECT button (17, 19)</li> <li>③ Numeric buttons</li> <li>④ RETURN button (31)</li> <li>⑤ PAGE button (33)</li> <li>⑥ TOP MENU button (30, 31)</li> <li>⑦ Cursor selection (▲ Up, ▼ Down) - CH (+/-) buttons (13)</li> <li>⑧ Cursor selection (◀ Left, ▶ Right) - VOL (+/-) buttons (13)</li> <li>⑨ CHOICE button (15, 60)</li> <li>⑩ ◀◀/PREVIOUS button (24, 26, 51, 56)</li> <li>⑪ ■/CLEAR button (20, 22, 36, 51)</li> <li>⑫ ▶/SELECT button (19, 21, 23, 30, 36, 51, 57)</li> <li>⑬ ◀◀/SLOW- button (26)</li> <li>⑭ REPEAT button (37, 53, 59)</li> <li>⑮ SUBTITLE button (39)</li> <li>⑯ DIGEST button (32)</li> </ul> | <ul style="list-style-type: none"> <li>⑰ 3D PHONIC button (44)</li> <li>⑱ ANGLE button (28, 41, 42)</li> <li>⑲ Infrared signal-emitting window (12)</li> <li>⑳ TV - DVD switch (13, 14, 29, 51, 55, 60)</li> <li>㉑ TV STANDBY/ON ⏻/⏻ button (13)</li> <li>㉒ DVD STANDBY/ON ⏻/⏻ button (14)</li> <li>㉓ TV/VIDEO - CANCEL button (13, 29, 35)</li> <li>㉔ TITLE/GROUP button (31, 53, 58)</li> <li>㉕ MENU button (30)</li> <li>㉖ ENTER button</li> <li>㉗ ON SCREEN button (27, 31, 35, 36, 38, 46)</li> <li>㉘ ▶▶/NEXT button (24, 26, 51, 56)</li> <li>㉙ ⏏/STROBE button (20, 26, 42, 51)</li> <li>㉚ ▶▶/SLOW+ button (26)</li> <li>㉛ AUDIO-fs/Rate button (40, 45, 54)</li> <li>㉜ VFP - PROGRESSIVE SCAN button (8, 43)</li> <li>㉝ ZOOM +/- buttons (43, 57)</li> <li>㉞ AMP VOL +/- buttons (13)</li> </ul> |
|--|--|

Additional information

## AV COMPU LINK remote control system

The JVC AV COMPU LINK system allows you to enjoy video or audio with the simplest operation. If your video/audio player (such as a DVD player, CD player and VCR) and television or/and amplifier/receiver support the JVC AV COMPU LINK system and are tied with the JVC AV COMPU LINK cable(s), when you simply starting the player, all the necessary settings of the television and/or amplifier/receiver for enjoying playback are automatically performed.

### AV COMPU LINK

### Connection and setup

Using the AV COMPU LINK cable, connect the AV COMPU LINK terminals of each component to one another.

- The unit's AV COMPU LINK setting is operated in the OTHERS page in the preference display. See page 67 for operation.
- For information on the connection between the TV and the receiver, refer to the receiver's Instructions.

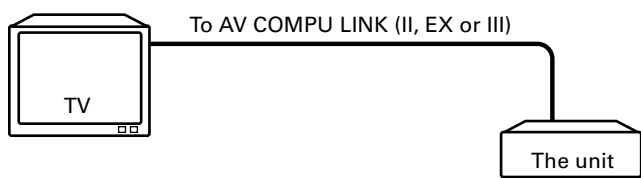

- If you connect the unit to a television via AV COMPU LINK, set the unit's AV COMPU LINK setting as follows.
  - When connecting to VIDEO-1 input terminal of the television: DVD2
  - When connecting to VIDEO-2 input terminal of the television: DVD3

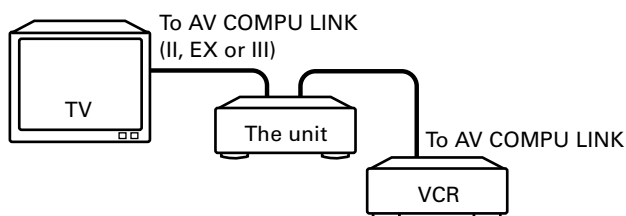

- If you connect the unit to a television and VCR via AV COMPU LINK, set the VCR's Remote Control Code and the unit's AV COMPU LINK setting as follows.
  - When connecting to VIDEO-1 input terminal of the television:  
The unit's AV COMPU LINK setting: DVD2  
VCR's Remote Control Code: B
  - When connecting to VIDEO-2 input terminal of the television:  
The unit's AV COMPU LINK setting: DVD3  
VCR's Remote Control Code: A

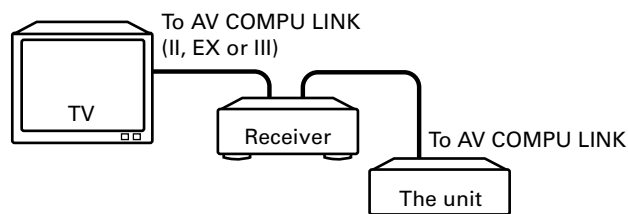

- If you connect the unit to a television and receiver via AV COMPU LINK, set the unit's AV COMPU LINK setting to DVD1.

#### IMPORTANT!

- When you make video connection between the unit and another device (such as a receiver and TV) via the composite, S-video or component jacks, as well as AV COMPU LINK connection, see also the instruction manual of the other device.

#### Notes for connection

- If you connect the unit to a receiver via AV COMPU LINK in a system including a Dolby Digital decoder, some functions may not be performed automatically.
- Connect the AUDIO OUT jacks of the unit to the audio input jacks of a receiver that indicating "DVD." Otherwise, the system will not work correctly.
- There may be no description about connections to the unit in the instruction manual of a television or VCR. However a television or VCR with AV COMPU LINK terminals indicating "II," "EX" or "III" can be connected to the unit.

### Operation

You can enjoy pictures and/or sound by just putting a source component (which plays back the pictures and/or sound such as a DVD player or VCR) into play mode. You do not have to operate the TV and receiver including not having to perform power switching.

- 1 Turn on the main power of the television.
- 2 Insert a disc (or tape) into the source component.
- 3 Press ► of the source component.

The following actions are performed automatically:

- Turning on the power for the television.
- Setting the source of the television to the external input (VIDEO-1 or VIDEO-2).
- Turning on the power for the receiver.
- Setting the source of the receiver to the component which has started playback.

## Troubleshooting

What appears to be a malfunction may not always be serious. Please go through the following list before requesting service.

POWER		
Symptom	Possible cause	Remedy
Power does not come on.	Power plug is not inserted securely.	Plug in securely.
OPERATION		
Symptom	Possible cause	Remedy
The remote control unit does not work.	Too far from the unit.	More closer to the unit.
	The tip of the remote control unit is not pointed in the right direction.	Point the infrared light- emitting window toward the remote sensor on the front panel (see page 12).
	Batteries are exhausted.	Replace the batteries with new ones.
	Battery polarity is incorrect.	Take out the batteries and insert them again in the correct direction.
	The remote control unit is not set for operating your TV.	Set the remote control unit for operating your TV (see page 13).
The TV/VIDEO - CANCEL, ▲/▼/◀/▶ or numeric buttons do not work.	The TV - DVD switch is not correctly set.	To control the unit, set the TV - DVD switch to "DVD." To control your TV, set the TV - DVD switch to "TV" (see page 13).
Operation is not possible.	Microcomputer malfunction due to lightning or static electricity.	Turn off the power and unplug the power cord, then connect the power cord again.
	Moisture condensation caused by a sudden change of temperature or humidity.	Turn off the power, then turn it on a few hours later.
	The disc does not allow the operation. Or a non-playable disc is loaded.	Check and replace the disc (see page 4).
The disc tray carousel does not move.	The system malfunctions. An alien substance is jammed on the carousel.	Press ■ or turn off the power.
When using the TITLE/GROUP button to select a title during DVD VIDEO playback, ⊙ appears on the TV screen and the title cannot be selected.	The disc does not allow the operation because of disc contents.	Try to press ■ and select a title using the numeric buttons on the remote control unit.

<b>PICTURE</b>		
<b>Symptom</b>	<b>Possible cause</b>	<b>Remedy</b>
No picture is displayed on the monitor.	Connection of video cable is incorrect.	Connect the cable correctly.
	Input selection of TV is incorrect.	Select correctly.
	Disc is not playable.	Use a playable disc (see page 4).
No picture is displayed on the monitor or the screen is blurred or divided into two parts.	The Progressive scanning mode is set to ON though the unit is connected to a TV via the VIDEO OUT jack.	Set the Progressive scanning mode to OFF (see page 8).
A picture is noisy or blurred.	The unit is connected to a VCR directly and the copyguard function is activated.	Connect the unit so that the picture signal flows directly to the TV.
	With some discs, a picture may be blurred when setting "PROGRESSIVE MODE" to "FILM" or "AUTO."	Set "PROGRESSIVE MODE" to "VIDEO" (see page 63).
A picture does not fit the television screen.	"MONITOR TYPE" is not correctly set.	Select monitor type correctly (see page 63).
	Television is not correctly set.	Set the television correctly.
The upper and lower parts of the preference display are cut off when using wide-aspect TV.	It depends on the setting on the TV.	Adjust the TV screen using the control on the TV.
<b>AUDIO</b>		
<b>Symptom</b>	<b>Possible cause</b>	<b>Remedy</b>
No audio is reproduced.	Connection is incorrect.	Check the connection.
	Input selection of amplifier is incorrect.	Select correctly.
Audio volume is low when playing back the unit, compared with the TV or VCR.	The audio level recorded on a DVD VIDEO is lower, compared with TV broadcasting.	Turn up the volume of the TV or amplifier/receiver. Note that you should turn down the volume before switching back to TV broadcasting, to prevent outputting the sudden big sound.
Sound is distorted or noise is generated.	Disc is dirty.	Wipe the disc surface (see page 5).
"MULTI CH" is shown in the display window when playing back a DVD AUDIO disc.	The track is prohibited from down-mixing to 2-channel stereo audio.	Listen in multichannel surround audio.

## Frequently Asked Questions

Question	Answer	Ref. page
Can I play back DVD VIDEO and Video CD purchased abroad?	You can play back the DVD VIDEO discs with the Region Code (local code) containing "ALL" or "1" recorded in the NTSC or PAL system (PAL disc signals are reproduced by converting to the NTSC system). You can also play back the Video CD discs recorded in the NTSC system. Please check the information on each disc jacket.	4
Can I play back a DVD VIDEO disc without any Region Code number?	The Region code indicates the conformity of the disc to the standards. Any DVD VIDEO not conforming to the standards cannot be played back.	4
Can I play back a CD-R/RW disc with still pictures in other than the JPEG format?	No, you cannot play back that disc.	4
Can I play back audio on a disc labeled "Dolby Digital EX"?	Yes, you can play back the disc because Dolby Digital EX is compatible with Dolby Digital. However, to get the maximum performance of Dolby Digital EX, we recommend to connect the DIGITAL OUT jack to a decoder or amplifier/receiver with built-in decoder that supports Dolby Digital EX. In this case, set "DIGITAL AUDIO OUTPUT" on the "AUDIO" preference display to "STREAM/PCM."	64
Can I play back audio on a disc labeled "DTS ES"? Is there any difference in the playback settings between Discrete and Matrix recording systems for DTS ES?	Though you cannot enjoy audio using the analog audio outputs (AUDIO OUT), you can enjoy DTS ES audio by connecting the DIGITAL OUT jack to a decoder or amplifier/receiver with built-in decoder that supports DTS ES. In this case, set "DIGITAL AUDIO OUTPUT" on the "AUDIO" preference display to "STREAM/PCM."	64
Can this unit play back a disc labeled "THX"? What does "THX" mean?	Yes you can. "THX" is a name of the original standard for high quality picture/audio recording and playback established by Lucasfilm Ltd. A disc labeled "THX" is certified that it passed this standard.	—
When files of the MP3 and Audio CD formats are recorded on a same disc, can the unit play back files of both formats?	The disc is of the data CD format, therefore, the unit can play back only files of the MP3 format.	4, 51
Some Dolby Digital discs contain 5.1-ch Surround or Dolby Surround audio data. What is the difference between these two types?	Both are surround sound standards developed by Dolby Laboratories Inc. in the U.S.A. Dolby Surround records 2-channel surround audio information are recorded onto the analog stereo (left and right) channels together with front stereo audio information. When played back, the surround signals are separated by a Dolby Surround or Dolby Pro Logic decoder. Dolby Digital digitally encodes and records up to six channel information for left, right, center, rear left, rear right and LFE (Low-Frequency Effect for Sub-woofer etc.). When played back, a Dolby Digital decoder decodes data and outputs signals separately. Generally, Dolby Digital sounds better.	4
When playing back a DVD VIDEO or Video CD disc, something like mosaic appears on the TV screen. Is this because of a malfunction of the unit?	It is a block noise specific to a motion picture recorded in digital, and is not a malfunction of the unit.	—
The unit does not function as described in this Instruction Manual.	The operation of this unit may occasionally be unacceptable due to the intention of the disc contents creator and/or structural restrictions.	—
Can I record DVD VIDEO data on a video tape?	Most of all DVD VIDEO discs are copy-protected so that you cannot record DVD VIDEO data onto any video tape.	3
Can this unit record data?	No, you cannot.	—



# Specifications

\*Specifications and appearance subject to change without prior notice.

## General

Readable discs: DVD AUDIO, DVD VIDEO, DVD-R (Video format), SVCD, Video CD, Audio CD (CD-DA), MP3 Format, JPEG, CD-R/RW (CD-DA, SVCD, Video CD, MP3 Format, JPEG)

Video format: NTSC, 480i (Interlaced scan)/480p (Progressive scan) selectable

## Other

Power requirements: AC 120 V  $\sim$ , 60 Hz

Power consumption: 18 W (POWER ON), 2.7 W (STANDBY mode)

Mass: 5.6 kg (12.4 lbs)

Dimensions (W x H x D): 435 mm x 102 mm x 448 mm  
(17-3/16 inch x 4-1/16 inch x 17-11/16 inch)

## Video outputs

COMPONENT (pin jacks): Y Output: 1.0 Vp-p (75  $\Omega$ )  
P<sub>B</sub>/P<sub>R</sub> Output: 0.7 Vp-p (75  $\Omega$ )

VIDEO OUT (pin jack): 1.0 Vp-p (75  $\Omega$ )

S-VIDEO OUT (S jack): Y Output: 1.0 Vp-p (75  $\Omega$ )  
C Output: 286 mVp-p (75  $\Omega$ )

Horizontal resolution: 500 Lines or more

## Audio outputs

ANALOG OUT (pin jack): 2.0 Vrms (10 k $\Omega$ )

DIGITAL OUT: (COAXIAL): 0.5 Vp-p (75  $\Omega$  termination)

(OPTICAL): -21 dBm to -15 dBm (peak)

## Audio characteristics

Frequency response: CD (sampling frequency 44.1 kHz): 2 Hz to 20 kHz  
DVD (sampling frequency 48 kHz): 2 Hz to 22 kHz  
(2 Hz to 20 kHz for DTS and Dolby Digital bitstream signals)

DVD (sampling frequency 96kHz/88.2 kHz): 2 Hz to 44 kHz  
DVD (sampling frequency 192kHz/176.4 kHz): 2 Hz to 88 kHz

Dynamic range: 16 bit: More than 98 dB  
20/24 bit: More than 108 dB

Wow and flutter: Unmeasurable (less than  $\pm$  0.002%)

Total harmonic distortion: 16 bit: Less than 0.0018%  
20/24 bit: Less than 0.0012%

## Appendix A: Country/Area code list for Parental Lock

This list is used for the Parental Lock operation. For details, see page 70.

AD	Andorra
AE	United Arab Emirates
AF	Afghanistan
AG	Antigua and Barbuda
AI	Anguilla
AL	Albania
AM	Armenia
AN	Netherlands Antilles
AO	Angola
AQ	Antarctica
AR	Argentina
AS	American Samoa
AT	Austria
AU	Australia
AW	Aruba
AZ	Azerbaijan
BA	Bosnia and Herzegovina
BB	Barbados
BD	Bangladesh
BE	Belgium
BF	Burkina Faso
BG	Bulgaria
BH	Bahrain
BI	Burundi
BJ	Benin
BM	Bermuda
BN	Brunei Darussalam
BO	Bolivia
BR	Brazil
BS	Bahamas
BT	Bhutan
BV	Bouvet Island
BW	Botswana
BY	Belarus
BZ	Belize
CA	Canada
CC	Cocos (Keeling) Islands
CF	Central African Republic
CG	Congo
CH	Switzerland
CI	Côte d'Ivoire
CK	Cook Islands
CL	Chile
CM	Cameroon
CN	China
CO	Colombia
CR	Costa Rica
CU	Cuba
CV	Cape Verde
CX	Christmas Island
CY	Cyprus
CZ	Czech Republic
DE	Germany
DJ	Djibouti
DK	Denmark
DM	Dominica
DO	Dominican Republic
DZ	Algeria
EC	Ecuador
EE	Estonia
EG	Egypt
EH	Western Sahara
ER	Eritrea
ES	Spain
ET	Ethiopia
FI	Finland
FJ	Fiji
FK	Falkland Islands
FM	Micronesia (Federated States of)
FO	Faroe Islands
FR	France
FX	France, Metropolitan
GA	Gabon
GB	United Kingdom
GD	Grenada
GE	Georgia
GF	French Guiana
GH	Ghana
GI	Gibraltar
GL	Greenland
GM	Gambia
GN	Guinea
GP	Guadeloupe
GQ	Equatorial Guinea
GR	Greece
GS	South Georgia and the South Sandwich
GT	Guatemala
GU	Guam
GW	Guinea-Bissau
GY	Guyana
HK	Hong Kong
HM	Heard Island and McDonald Islands
HN	Honduras
HR	Croatia
HT	Haiti
HU	Hungary
ID	Indonesia
IE	Ireland
IL	Israel
IN	India
IO	British Indian Ocean Territory
IQ	Iraq
IR	Iran (Islamic Republic of)
IS	Iceland
IT	Italy
JM	Jamaica
JO	Jordan
JP	Japan
KE	Kenya
KG	Kyrgyzstan
KH	Cambodia
KI	Kiribati
KM	Comoros
KN	Saint Kitts and Nevis
KP	Korea, Democratic People's Republic of
KR	Korea, Republic of
KW	Kuwait
KY	Cayman Islands
KZ	Kazakhstan
LA	Lao People's Democratic Republic
LB	Lebanon
LC	Saint Lucia
LI	Liechtenstein
LK	Sri Lanka
LR	Liberia
LS	Lesotho
LT	Lithuania
LU	Luxembourg
LV	Latvia
LY	Libyan Arab
MA	Morocco
MC	Monaco
MD	Moldova, Republic of
MG	Madagascar
MH	Marshall Islands
ML	Mali
MM	Myanmar
MN	Mongolia
MO	Macau
MP	Northern Mariana Islands
MQ	Martinique
MR	Mauritania
MS	Montserrat
MT	Malta
MU	Mauritius
MV	Maldives
MW	Malawi
MX	Mexico
MY	Malaysia
MZ	Mozambique
NA	Namibia
NC	New Caledonia
NE	Niger
NF	Norfolk Island
NG	Nigeria
NI	Nicaragua
NL	Netherlands
NO	Norway
NP	Nepal
NR	Nauru
NU	Niue
NZ	New Zealand
OM	Oman
PA	Panama
PE	Peru
PF	French Polynesia
PG	Papua New Guinea
PH	Philippines
PK	Pakistan
PL	Poland
PM	Saint Pierre and Miquelon
PN	Pitcairn
PR	Puerto Rico
PT	Portugal
PW	Palau
PY	Paraguay
QA	Qatar
RE	Réunion
RO	Romania
RU	Russian Federation
RW	Rwanda
SA	Saudi Arabia
SB	Solomon Islands
SC	Seychelles
SD	Sudan
SE	Sweden
SG	Singapore
SH	Saint Helena
SI	Slovenia
SJ	Svalbard and Jan Mayen
SK	Slovakia
SL	Sierra Leone
SM	San Marino
SN	Senegal
SO	Somalia
SR	Suriname
ST	Sao Tome and Principe
SV	El Salvador
SY	Syrian Arab Republic
SZ	Swaziland
TC	Turks and Caicos Islands
TD	Chad
TF	French Southern Territories
TG	Togo
TH	Thailand
TJ	Tajikistan
TK	Tokelau
TM	Turkmenistan
TN	Tunisia
TO	Tonga
TP	East Timor
TR	Turkey
TT	Trinidad and Tobago
TV	Tuvalu
TW	Taiwan
TZ	Tanzania, United Republic of
UA	Ukraine
UG	Uganda
UM	United States Minor Outlying Islands
US	United States
UY	Uruguay
UZ	Uzbekistan
VA	Vatican City State (Holy See)
VC	Saint Vincent and the Grenadines
VE	Venezuela
VG	Virgin Islands (British)
VI	Virgin Islands (U.S.)
VN	Vietnam
VU	Vanuatu
WF	Wallis and Futuna Islands
WS	Samoa
YE	Yemen
YT	Mayotte
YU	Yugoslavia
ZA	South Africa
ZM	Zambia
ZR	Zaire
ZW	Zimbabwe

## Appendix B: Glossary

### 480i/480p

Indicates the number of scanning lines and scanning format of an image signal. 480i indicates 480 scanning lines with interlaced format, and 480p indicates 480 scanning lines with progressive format.

### Aspect ratio

A ratio which defines the shape of the rectangular picture in a TV. It is the width of the picture relative to the height. The conventional TV picture is 4:3 in aspect ratio.

### Bitstream

The digital form of multichannel audio data (e.g., 5.1-channel) before it is decoded into its various channels.

### Channel, CH

Stereo or multichannel audio consists of "channel" signals. "Stereo" audio consists of left and right channels, while 5.1-channel Dolby Digital consists of six channels (front left, front right, rear left, rear right, center and LFE (Low-Frequency Effect) channel for sub-woofer, etc.).

### Chapter

The smallest division on DVD VIDEO. It is a division of a title and similar to a track for Audio CD or Video CD.

### Component video

Video signals with three channels of separate information that makes up the picture. There are some types of component video, such as R/G/B and Y/C<sub>B</sub>(P<sub>B</sub>)/C<sub>R</sub>(P<sub>R</sub>).

### Composite video

A single video signal commonly used in most consumer video products that contains all luminance, color, and synchronization information.

### Dolby Digital (AC3)

A six-channel system consisting of left, center, right, left rear, right rear and LFE (Low-Frequency Effect channel for sub-woofer, etc.) channels. All processing is done in the digital domain.

Not all Dolby Digital discs contain six (5.1) channel information.

### Dolby Surround/Dolby Prologic

Dolby Surround is a five-channel system consisting of left, center, right and left rear, right rear channels. All processing is done in the digital domain.

Dolby Prologic is a four-channel system consisting of left, center, right and rear channel (the single rear channel is usually played through two speakers).

### Down-mix

Internal stereo mix of multichannel surround audio by a DVD player. The down-mix signals are output from stereo output connectors.

### DTS

A Digital Surround audio encoding format configured with six (5.1) channels, similar to Dolby Digital. It requires a decoder, either in the player or in an external receiver. DTS stands for Digital Theater Systems.

Not all DTS discs contain six (5.1) channel information.

### Dynamic range

The difference between the loudest and softest sounds.

### Dynamic range compression

The dynamic range compression (DRC) reduces the dynamic range so that you can turn down the volume to avoid disturbing others yet still hear the detail of quiet passages.

### Extension

Several letters at the end of a file name. File name extensions usually follow a period and indicate the type of information stored in the file.

### Finalize

When conducting multisession recording, this means the closing of a session (fixing) by indicating the halting of writing so as to prevent the addition of any more sessions.

### Fs

See "Sampling frequency."

### Group

The largest division on DVD AUDIO.

### ID3 tag

The tag embedded in an MP3 file indicating what songs, artists, and album they comes from. You can edit these tags.

### Interlaced scan

In the conventional video system, a picture is shown on the display monitor in two halves. The Interlaced scanning system places lines of the second half of the picture in-between lines of the first half of the picture.

### ISO 9660 Format

The most common international standard for the logical format for files and directories on a CD-ROM.

### JPEG

A popular file format for still image compression. JPEG stands for Joint Photographic Experts Group. There are three sub-types of the JPEG format as follows.

- baseline JPEG: used for digital cameras, web, etc.
- progressive JPEG: used for web.
- lossless JPEG: an old type and rarely used now.

**Letter box**

A type of picture playback with the normal (4:3) TV screen. Black bars are shown at the top and bottom of the image to allow playing of wide-screen (16:9) DVD movie without cutting off any sides of the image on a 4:3 TV.

**Linear PCM audio**

Stands for "pulse code modulation." Linear PCM is the usual digital method without compression, used for audio playback of DVD Video discs, Audio CD discs, etc.

**Menu**

Most DVD AUDIO, DVD VIDEO or SVCD/Video CD discs provide a menu, through which users can select a desired playback material, condition, etc.

**MLP**

MLP stands for "Meridian Lossless Packing." A lossless audio compression system that can completely recreate the PCM signal.

**MP3**

MP3 is an audio data reduction format, which stands for MPEG-1 Audio Layer 3. Using MP3, you can achieve a data reduction of about 1:10.

**MPEG**

A family of Standards for compressing audio-visual information. "MPEG" standards include MPEG-1, MPEG-2 and MPEG-4. Video CD and MP3 are based on MPEG-1, while DVD is based on MPEG-2. MPEG stands for Moving Picture coding Experts Group.

**Multisession**

A method of adding data to a CD-R/CD-RW in more than one recording session using the Track-At-Once method.

**NTSC (National television system committee)**

A black & white and color television system format used in U.S.A., Canada, Mexico and Japan.

**Packet Writing**

A method of writing data on a CD-R/CD-RW in small increments. Packets can be of fixed or variable length.

**PAL (Phase Alternation by Line)**

A color television system format used extensively in Western Europe.

**Pan scanning**

A type of picture playback with the normal (4:3) TV screen, which is panned and zoomed across the wider movie picture, chopping off the left and right sides.

**Parental lock**

A DVD function that prevents undesired viewing by children depending on disc contents. You need a password to play back a locked disc in the normal condition. Otherwise, undesirable scenes are automatically skipped or replaced with other pictures.

**PBC**

PBC stands for "Playback control" and is a method of controlling disc play for Video CDs (VCD). You are able to interact with the disc through menus.

**Progressive scan**

Progressive scanning displays all the horizontal lines of a picture at one time, as a single frame. A progressive-scanning DVD player converts the interlaced (480i) video from DVD into progressive (480p) format for connection to a progressive display. It dramatically increases the vertical resolution.

**Region code**

Code identifying a geographic region of compatibility for a DVD.

**Sampling frequency**

The rate at which measurements of an audio signal are taken during A/D and D/A conversion. The measure is samples per second.

**Surround**

An audio system with more than two (left and right) channels, usually including rear channels, etc.

**S-video**

A video signal which improves picture quality over standard composite connections. Used on Super VHS, DVD, high end TV monitors, etc.

**Title**

The largest division on DVD VIDEO.

**Track**

The smallest division on DVD AUDIO, SVCD, Video CD and Audio CD discs.

**Transfer rate**

The rate of transferring digital data. Usually the measure is in baud per second. The DVD system applies variable transfer rate system for high efficiency.

# Appendix C: Index

## Numerics

3D PHONIC ..... 44, 45, 65

## A

A-B repeat..... 38, 39, 47, 48, 49

Angle..... 19, 41, 42, 49

Audio language..... 19, 40, 48, 49, 61

Auto standby..... 67

AV COMPU LINK..... 7, 9, 10, 67, 75

AV COMPULINK mode ..... 67

## B

Bonus group..... 5, 34

## C

Chapter ..... 5, 21, 24, 25, 27, 30, 32, 33, 37, 38, 39, 48

Chapter search ..... 48

Component video ..... 2, 7, 75, 79

Copyguard system..... 3

Copy-protected disc..... 6

Country code..... 70, 72, 80

## D

D. range compression ..... 10, 65

Digest..... 32, 33

Digital audio output..... 4, 10, 16, 64

Direct selection ..... 53

Disc resume..... 20, 22, 23, 67

Dolby..... 3, 75

Dolby Digital..... 4, 10, 16, 45, 64, 65, 75, 79

DTS ..... 3, 4, 10, 16, 64, 79

DVD menu ..... 30

DVD PLAYER SET UP ..... 15

## E

Extension..... 51, 55

## F

Finalize..... 4, 51, 55

## G

Group..... 5, 24, 25, 27, 30, 31, 35, 37,  
47, 51, 52, 53, 55, 56, 58, 59

## I

ID3 tag..... 51

Initial setting..... 15, 16, 60

Initial setup..... 15

Interlaced scanning ..... 7, 8

ISO 9660 ..... 51, 55

## J

JPEG ..... 4, 51, 55, 56, 59, 61, 64

JPEG CONTROL ..... 56, 57, 58, 59

JPEG disc..... 3, 23, 55, 56, 57, 61

## L

Language code..... 61

Linear PCM..... 4, 64

## M

Macrovision..... 3

Manufacturer code ..... 13

Menu..... 5, 15, 18, 19, 25, 30, 31, 47, 48,  
49, 60, 61, 63, 64, 65, 67, 70, 71, 72

Menu bar ..... 28, 31, 32, 35, 36, 37, 38, 39,  
40, 41, 42, 46, 47, 48, 49

Menu language..... 61

Monitor type..... 15, 63, 77

MP3 ..... 4, 51, 52, 53, 55, 64

MP3 CONTROL..... 52, 53, 61

MP3 disc ..... 3, 23, 51, 61

MPEG ..... 16, 51, 64

Multi-angle part ..... 41, 49

Multiple session..... 51, 55

## N

NTSC..... 4, 7, 79

## O

One touch replay function..... 21

On-screen guide..... 19, 67

On-screen language ..... 15, 61

Opening display..... 14, 16, 18

## P

Packet writing..... 51, 55

PAL..... 4

Pan scanning ..... 63

Parental lock..... 67, 70, 71, 72, 80

Playback control (PBC) ..... 5, 23, 24, 25, 30, 31, 32, 37, 38

Preference ..... 9, 10, 15, 16, 19, 22, 23, 39, 40, 41,  
43, 51, 55, 60, 61, 70, 71, 72, 75

Program (playback)..... 35, 36, 37, 47, 50

Progressive mode..... 63, 77

Progressive scanning ..... 7, 8, 43, 63, 77

## R

Random (playback)..... 36, 47, 50

Region code ..... 4, 14, 18

Repeat (playback)..... 37, 38, 39, 47, 48, 49, 53, 59

Resume (playback)..... 20, 22, 23, 67

## S

Sampling rate..... 4

Scanning mode..... 7, 8, 63, 77

Screen saver..... 19, 55, 64

Slide show..... 57, 58

Slide show mode ..... 57, 59

Slide show playback..... 57, 58

Slow-motion..... 19, 26, 28

Status bar ..... 27, 28, 36, 39, 40, 41, 46, 47, 48, 49

Strobe (playback)..... 42

Subtitle language..... 19, 39, 40, 49

S-video..... 6, 7, 79

## T

Time search..... 31, 32, 47, 48, 50

Transfer rate ..... 27, 51

Transport status ..... 27, 28

## V

VFP (Video fine processor)..... 8, 43, 44

## Z

Zoom (playback) ..... 43, 57

# Authorized Service Centers

---

QUALITY **JVC**<sup>®</sup> SERVICE

*HOW TO LOCATE YOUR JVC SERVICE CENTER*

**TOLL FREE: 1 (800) 537-5722**

**<http://www.jvc.com>**

Dear Customer,

In order to receive the most satisfaction from your purchase, please read the instruction booklet before operating the unit. In the event that repairs are necessary, please call 1 (800)537-5722 for your nearest authorized servicer or visit our website at **[www.JVC.com](http://www.JVC.com)**

Remember to retain your Bill of Sale for Warranty Service.

---

## **Do not service the television yourself**

---

### **Caution**

To prevent electrical shock, do not open the cabinet. There are no user serviceable parts inside. Please refer to qualified service personnel for repairs.

### **Accessories**

To purchase accessories for your JVC product, please call toll free: 1 (800)882-2345 or on the web at **[www.JVC.com](http://www.JVC.com)**

---



# LIMITED WARRANTY

## CONSUMER VIDEO 1-90

JVC COMPANY OF AMERICA warrants this product and all parts thereof, except as set forth below ONLY TO THE ORIGINAL PURCHASER AT RETAIL to be FREE FROM DEFECTIVE MATERIALS AND WORKMANSHIP from the date of original retail purchase for the period as shown below. ("The Warranty Period")

PARTS	<b>1 YR</b>	LABOR	<b>90 DAYS</b>
-------	-------------	-------	----------------

THIS LIMITED WARRANTY IS VALID ONLY IN THE FIFTY (50) UNITED STATES, THE DISTRICT OF COLUMBIA AND IN COMMONWEALTH OF PUERTO RICO.

### WHAT WE WILL DO:

If this product is found to be defective, JVC will repair or replace defective parts at no charge to the original owner. Such repair and replacement services shall be rendered by JVC during normal business hours at JVC authorized service centers. Parts used for replacement are warranted only for the remainder of the Warranty Period. All products and parts thereof may be brought to a JVC authorized service center on a carry-in basis except for Television sets having a screen size 25 inches and above which are covered on an in-home basis.

### WHAT YOU MUST DO FOR WARRANTY SERVICE:

Return your product to a JVC authorized service center with a copy of your bill of sale. For your nearest JVC authorized service center, please call toll free: (800) 537-5722.

If service is not available locally, box the product carefully, preferably in the original carton, and ship, insured, with a copy of your bill of sale plus a letter of explanation of the problem to the nearest JVC Factory Service Center, the name and location of which will be given to you by the toll-free number.

If you have any questions concerning your JVC Product, please contact our Customer Relations Department.

### WHAT IS NOT COVERED:

This limited warranty provided by JVC does not cover:

1. Products which have been subject to abuse, accident, alteration, modification, tampering, negligence, misuse, faulty installation, lack of reasonable care, or if repaired or serviced by anyone other than a service facility authorized by JVC to render such service, or if affixed to any attachment not provided with the products, or if the model number or serial number has been altered, tampered with, defaced or removed;
2. Initial installation and installation and removal for repair;
3. Operational adjustments covered in the Owner's Manual, normal maintenance, video and audio head cleaning;
4. Damage that occurs in shipment, due to act of God, and cosmetic damage;
5. Signal reception problems and failures due to line power surge;
6. Video Pick-up Tubes/CCD Image Sensor, Cartridge, Stylus (Needle) are covered for 90 days from the date of purchase;
7. Accessories;
8. Batteries (except that Rechargeable Batteries are covered for 90 days from the date of purchase);

There are no express warranties except as listed above.

THE DURATION OF ANY IMPLIED WARRANTIES, INCLUDING THE IMPLIED WARRANTY OF MERCHANTABILITY, IS LIMITED TO THE DURATION OF THE EXPRESS WARRANTY HEREIN.

JVC SHALL NOT BE LIABLE FOR THE LOSS OF USE OF THE PRODUCT, INCONVENIENCE, LOSS OR ANY OTHER DAMAGES, WHETHER DIRECT, INCIDENTAL OR CONSEQUENTIAL (INCLUDING, WITHOUT LIMITATION, DAMAGE TO TAPES, RECORDS OR DISCS) RESULTING FROM THE USE OF THIS PRODUCT, OR ARISING OUT OF ANY BREACH OF THIS WARRANTY. ALL EXPRESS AND IMPLIED WARRANTIES, INCLUDING THE WARRANTIES OF MERCHANTABILITY AND FITNESS FOR PARTICULAR PURPOSE, ARE LIMITED TO THE WARRANTY PERIOD SET FORTH ABOVE.

Some states do not allow the exclusion of incidental or consequential damages or limitations on how long an implied warranty lasts, so these limitations or exclusions may not apply to you. This warranty gives you specific legal rights and you may also have other rights which vary from state to state.

JVC COMPANY OF AMERICA  
 DIVISION OF JVC AMERICAS CORP.

1700 Valley Road  
 Wayne, NJ 07470

REFURBISHED PRODUCTS CARRY A SEPARATE WARRANTY, THIS WARRANTY DOES NOT APPLY. FOR DETAILS OF REFURBISHED PRODUCT WARRANTY, PLEASE REFER TO THE REFURBISHED PRODUCT WARRANTY INFORMATION PACKAGED WITH EACH REFURBISHED PRODUCT.

#### For customer use:

Enter below the Model No. which is located either on the rear, bottom or side of the cabinet. Retain this information for future reference.

Model No. : \_\_\_\_\_ Serial No. : \_\_\_\_\_  
 Purchase data : \_\_\_\_\_ Name of dealer : \_\_\_\_\_

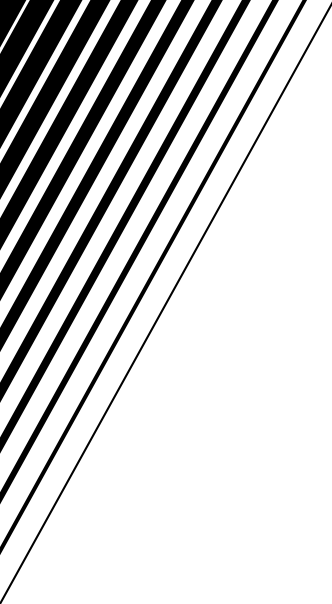

**JVC**  
VICTOR COMPANY OF JAPAN, LIMITED



## Free Manuals Download Website

<http://myh66.com>

<http://usermanuals.us>

<http://www.somanuals.com>

<http://www.4manuals.cc>

<http://www.manual-lib.com>

<http://www.404manual.com>

<http://www.luxmanual.com>

<http://aubethermostatmanual.com>

Golf course search by state

<http://golfingnear.com>

Email search by domain

<http://emailbydomain.com>

Auto manuals search

<http://auto.somanuals.com>

TV manuals search

<http://tv.somanuals.com>