

MV-P618 SUPER DIRECTIONAL MICROPHONE *Instructions*

This instruction book is made from 100% recycled paper.

Thank you for purchasing this SUPER DIRECTIONAL MICROPHONE. To get maximum benefit from its use, it is suggested that you read this instructions carefully. After reading, please keep this instructions for future reference.

COMPATIBLE UNITS

MV-P618 : JVC camera equipped with an XLR 3-pin connector supplying 48 V (phantom)

PRECAUTIONS

- MV-P618 is a SUPER DIRECTIONAL MICROPHONE exclusively for JVC color video cameras.
- Do not drop or hit the microphone. A strong shock may degrade the characteristics of microphone.
- Do not disassemble the microphone. The original performance may not be obtained.
- Be careful not to use or leave long time the microphone in a hot or humid place, such as, direct sunlight, near a heater, closed automobile in summer.

■ Notes for operation

- MV-P618 is a high-sensitivity microphone designed to give optimum performance. This is designed to give best performance at a certain distance from the source. Do not locate your microphone too close to the source. Otherwise the tone balance is disordered due to the proximity effect.
- A loud sound near the microphone may cause to distort the sound signal due to the built-in mic amp of the camera. In addition, the sound level may fluctuate due to AGC of VCR. (Adjust the volume control of the camera to avoid sound signal distortion.)
- When this unit is used on the GY-DV300, it may pick up the operating noise of the camera. To reduce this noise, set the menu item of the GY-DV300 WIND CUT in the SYSTEM [1/2] to ON. In this case, however, note that low frequencies may not be picked up properly.
- While recording, always monitor the sound level with headphone etc.
- Do not wet the microphone. (Especially when using in rainy conditions.)

INSTALLATION

(An example of mounting on the GY-DV300 by using KA-A33)

This unit can be installed on the camera using the optional KA-A33 microphone holder.

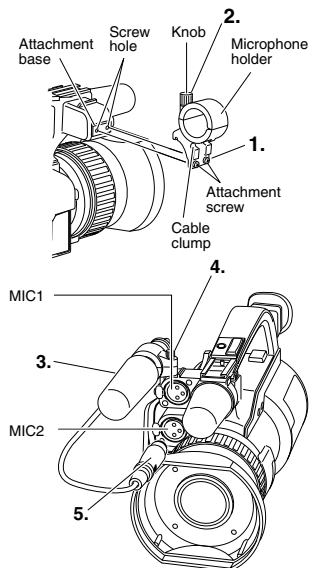

1. Loosen the mounting screws on the microphone holder and install the microphone holder on the mount base.
2. Turn the knob on the microphone holder counterclockwise to open the microphone holder.
3. Mount the microphone on the microphone holder.
4. Turn the knob on the microphone holder clockwise to clamp the microphone.
5. Attach the microphone cable to the cable clamp on the microphone holder and connect the cable to the MIC 1 or 2 input connector.

MICROPHONE CHARACTERISTICS

Standard Directional Characteristics

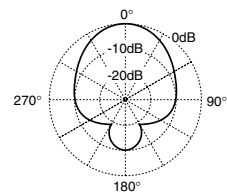

Standard Frequency Response

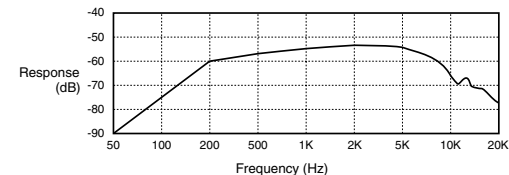

SPECIFICATIONS

Reception	: Second-order pressure gradient super-directional	Power supply voltage	: 48 V (Phantom)
Type	: Back-electret condenser type	Current consumption	: 2.6 mA
Sensitivity	: -62 dB (0 dB = 1 V/0.1 Pa, at 1 kHz, 0°)	Ambient temperature	: -5°C to 45°C
Frequency response	: 200 Hz to 10,000 Hz	Dimensions	: Microphone 160 mm(L) x 21 mm(Dia.) (With windscreen)
Output impedance	: 50 ± 20 Ω	Mass	: 85g (With windscreen)
Max. input SPL	: 115 dB SPL or more (1 kHz, 1% distortion, microphone itself)	Accessory	: Windscreen
S/N ratio	: More than 42 dB		
Connector	: 3-pin XLR (male)		

• Design and specification subject to change without notice.

JVC[®]
VICTOR COMPANY OF JAPAN, LIMITED

JVC[®] is a registered trademark owned by VICTOR COMPANY OF JAPAN, LTD.

JVC[®] is a registered trademark in Japan, the U.S.A., the U.K. and many other countries.

© 2002 VICTOR COMPANY OF JAPAN, LIMITED

Printed in Japan
LWT0056

Free Manuals Download Website

<http://myh66.com>

<http://usermanuals.us>

<http://www.somanuals.com>

<http://www.4manuals.cc>

<http://www.manual-lib.com>

<http://www.404manual.com>

<http://www.luxmanual.com>

<http://aubethermostatmanual.com>

Golf course search by state

<http://golfingnear.com>

Email search by domain

<http://emailbydomain.com>

Auto manuals search

<http://auto.somanuals.com>

TV manuals search

<http://tv.somanuals.com>