



VISUAL PRESENTER

MANUEL D'INSTRUCTIONS : PRÉSENTOIR DE VISUALISATION

AV-P720U

INSTRUCTIONS

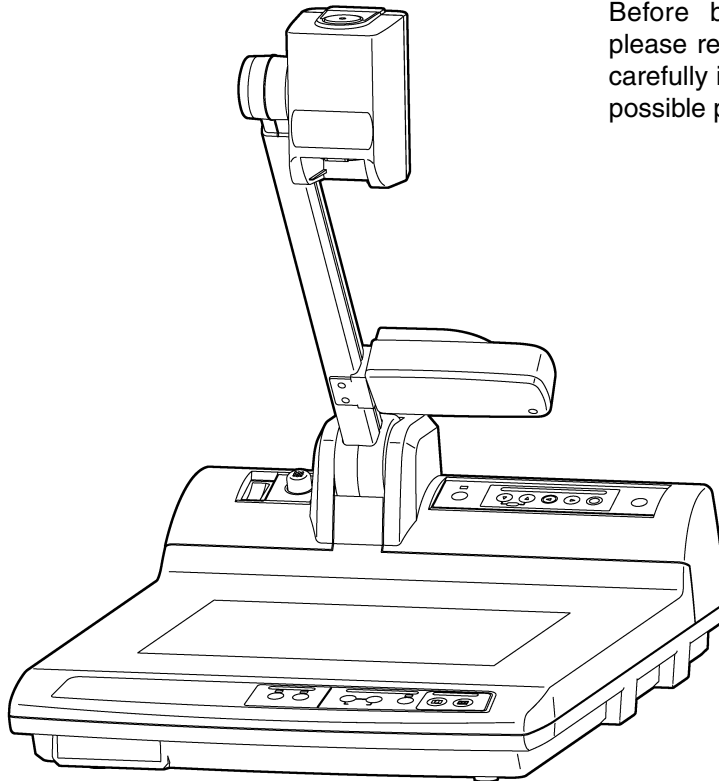

Before beginning to operate this unit, please read the INSTRUCTIONS MANUAL carefully in order to make sure that the best possible performance is obtained.

For Customer Use:

Enter below the Serial No. which are located on the fram.

Retain this information for future reference.

Model No. AV-P720U

Serial No. _____

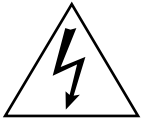
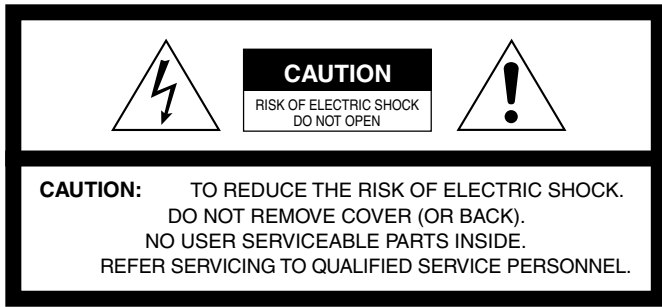

The lightning flash with arrowhead symbol, within an equilateral triangle is intended to alert the user to the presence of uninsulated "dangerous voltage" within the product's enclosure that maybe of sufficient magnitude to constitute a risk of electric shock to persons.



The exclamation point within an equilateral triangle is intended to alert the user to the presence of important operating and maintenance (servicing) instructions in the literature accompanying the appliance.

WARNING:
TO PREVENT FIRE OR SHOCK HAZARD, DO NOT EXPOSE THIS UNIT TO RAIN OR MOISTURE.

AVERTISSEMENT:
DE PREVENTION D'INCENDIE OU D'ELECTROCUTION, NE PAS EXPOSER CET APPAREIL A LA PLUIE OU L'HUMIDITE.

WARNING:
THIS IS A CLASS A PRODUCT. IN A DOMESTIC ENVIRONMENT THIS PRODUCT MAY CAUSE RADIO INTERFERENCE IN WHICH CASE THE USER MAY BE REQUIRED TO TAKE ADEQUATE MEASURES AT HIS OWN EXPENSE.

AVERTISSEMENT:
CECI EST UN APPAREIL DE CLASSE A. DANS UN ENVIRONNEMENT DOMESTIQUE CET APPAREIL PEUT CAUSER UNE INTERFERENCE RADIO DANS QUEL CAS L'UTILISATEUR PEUT AVOIR À PRENDRE DES MESURES ADÉQUATES À SES PROPRES FRAIS.

WARNING: This equipment generates, uses, and can radiate radio frequency energy. If not installed and used in accordance with the instruction manual, it may cause interference to radio communications. The rules with which it must comply afford reasonable protection against such interference when it is used in a commercial environment. Operation of this equipment in a residential area is likely to cause interference, in which case the user will be required to correct the interference at his own expense.

The instructions are given in two languages :

English from page 2 to 14 and French from page 15 to 26

Les instructions sont donnés en deux langues :

En anglais de la page 2 à 14 et en français de la page 15 à 26.

NOTE:

The rating plate (serial number plate) and safety caution are on the bottom and/or the back of the main unit.

Information for Canada

This Class A digital apparatus meets all requirements of the Canadian Interference-Causing Equipment Regulations.

Informations pour le Canada

Cet appareil numérique de la class A respecte toutes les exigences du Règlement sur le matériel brouilleur du Canada.

Thank you for purchasing the JVC AV-P720 Visual Presenter. To make the most of this unit's many features, please read this booklet carefully. After reading, keep it handy for future reference.

TABLE OF CONTENTS

SAFETY PRECAUTIONS	2
CONTENTS	3
CHARACTERISTICS	3
OPERATIONAL PRECAUTIONS	3
PARTS NAMES	4
Main Unit	4
Front Operation Panel	4
Rear Operation Panel	5
Back Panel	5
BEFORE STARTING	6
STORING THE EQUIPMENT	7
PRESENTATIONS	8
1. Presentation of Printed Matter and Three-dimensional Materials	8
2. Presentation of Slides	8
3. Filming Peripheral Subjects	8
OPERATION	9
Zooming	9
Focusing	9
Input Select	9
Lighting	10
Brightness	10
Auto White Set	10
On Screen Adjustment	11
Function	12
TROUBLESHOOTING	13
SPECIFICATIONS	14

CHARACTERISTICS

- This equipment is a presentation device that enables presentation materials such as slides to be shown on a monitor screen.
- Auto focus function automatically adjusts and corrects focus as required.
- The x 16 electric zoom lens enables materials of varying size from a 35mm slide to a lateral B4 size paper to be presented on a screen.

OPERATIONAL PRECAUTIONS

- Do not leave the equipment in direct sunshine or close to heating appliances.
- During operation do not cover the lighting device with flammable materials such as fabric or paper.
- When the main unit needs cleaning, wipe it first with a damp cloth that had been soaked in solution of neutral detergent and tightly wrung; then dry it off with clean cloth. Never use volatile solvents such as paint thinner, benzene, insecticide, etc. on the unit as they may deform, discolour and damage it. Also do not immerse the unit in water, as it will result in breakdown.

PARTS NAMES

Main Unit

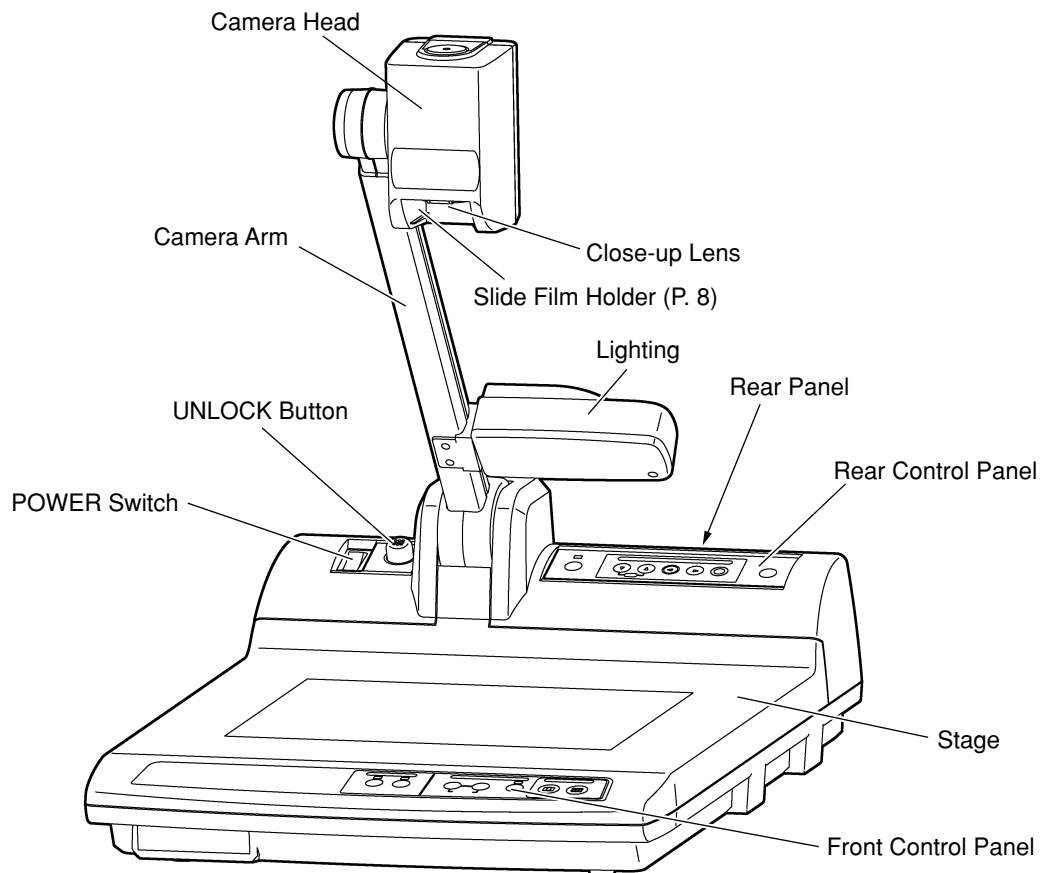

Front Operation Panel

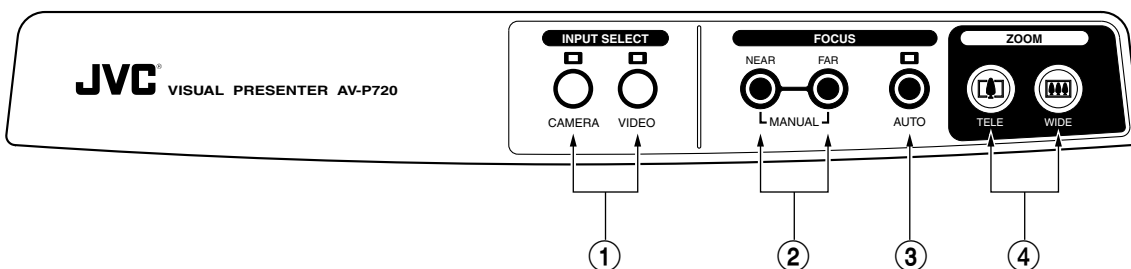

- ① INPUT SELECT button : changes the input system to the camera or video terminals. (P9)
- ② MANUAL FOCUS button : manually adjusts the camera focus. (P9)
- ③ AUTO FOCUS buttons : automatically adjusts the camera focus. (P9)
- ④ ZOOM button : changes the size of the material to be presented on a monitor screen. (P9)

Rear Operation Panel

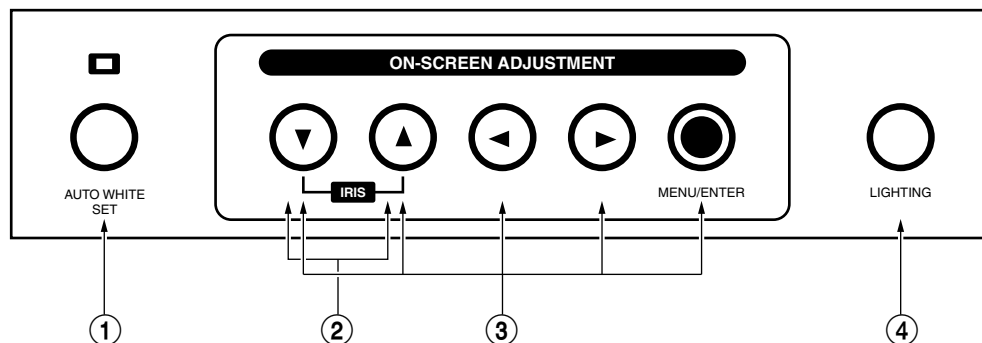

- ① AUTO WHITE SET button : selects the AUTO WHITE BALANCE ADJUSTMENT mode. (P10)
- ② IRIS button : adjusts brightness of the material presented on the monitor screen. (P10)
- ③ ON SCREEN ADJUSTMENT button : operates the ON SCREEN ADJUSTMENT function. (P11)
- ④ LIGHTING button : turns LIGHTING on/off. (P10)

Back Panel

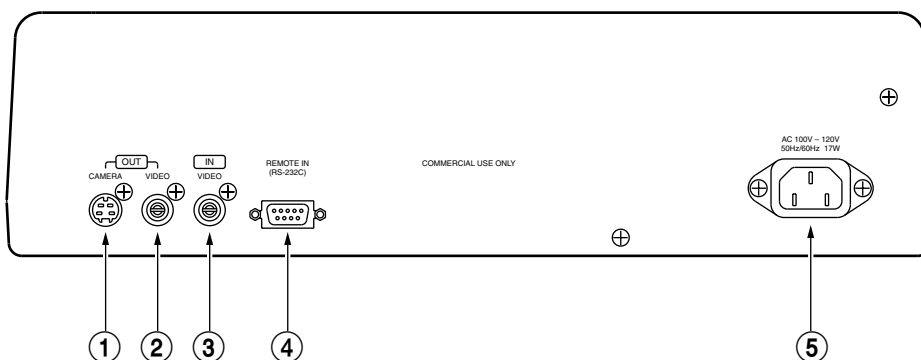

- ① CAMERA OUTPUT terminal : outputs camera image signals from the body regardless of setting of the INPUT SELECT button.
- ② VIDEO OUTPUT terminal : outputs image signals that have been selected by the INPUT SELECT button.
- ③ VIDEO INPUT terminal : is an input terminal for image signals from the external equipment. The signals that enter this terminal when 'VIDEO' was selected on the INPUT SELECT button will go out via the VIDEO OUTPUT terminal.
- ④ REMOTE INPUT terminal : is a RS-232C terminal that allows external functions, for instance by a PC, to control the operations. Information on communication protocols and commands is available separately. For details, consult your JVC dealer.
- ⑤ AC IN connector : connects the power cord. Please only use the power cord supplied.

BEFORE STARTING

1. Pull up the camera arm slightly towards the direction of ② while pressing the camera arm lock release button ①. Release the lock release button; then pull up the camera arm until the locking system engages completely.

Note:

- Do not let go of the camera arm while the lock release button is depressed. The camera arm section will drop down of its own weight and this could result in breakdown and/or injury.
- When pulling up the camera arm, make sure to pull it up by holding the arm section. If you try to pull up by holding either the camera section or the lighting section, it may cause breakdown.

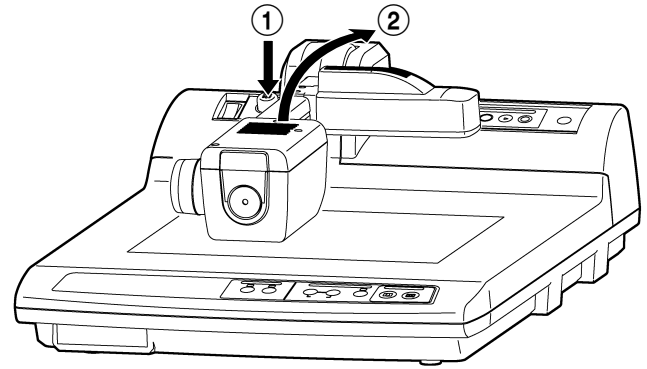

2. Rotate the camera head towards the direction of ③ until you hear a click and then let the lens section face towards the stage which is located directly below.

3. Carry out one or the other of the following connections depending on the type of a TV monitor image input terminal in use.

*We recommend the use of a S-image output because it can reduce bleeding at color borders.

Note:

- Signals that entered the VIDEO INPUT terminal can only come out of the VIDEO OUTPUT terminal. If you would like to use the VIDEO INPUT terminal make sure to connect the signals to the VIDEO OUTPUT terminal.

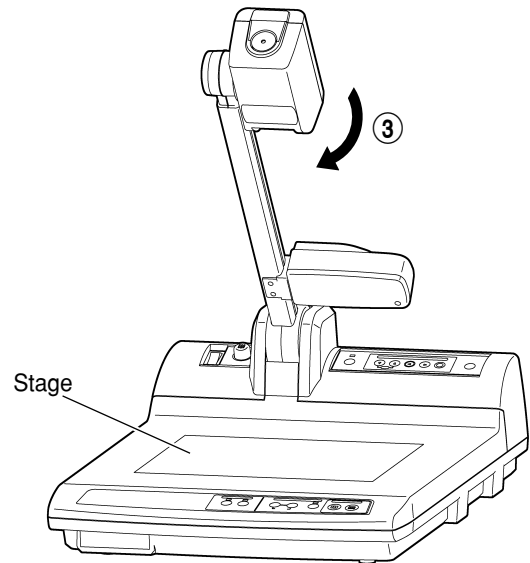

- **Connecting to the apparatus equipped with a composite video (C-video) input terminal**

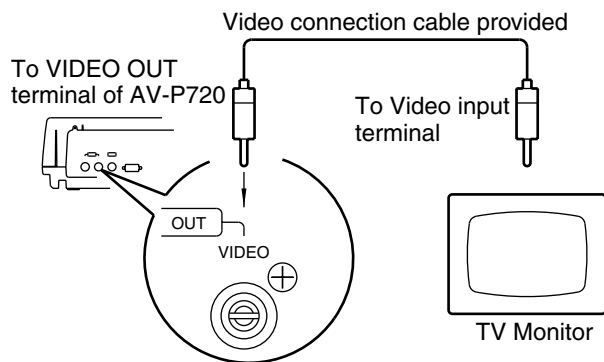

- **Connecting to the apparatus equipped with a S-image (S-video) input terminal**

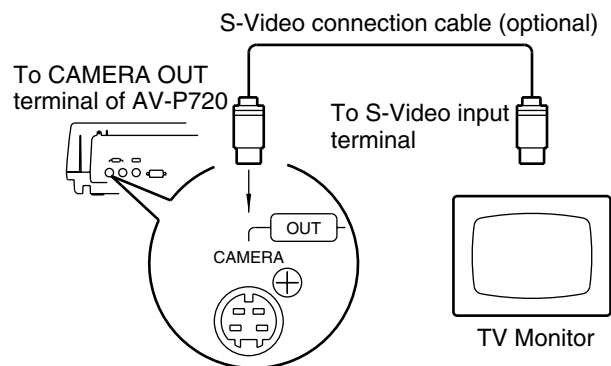

4. Connect the power cord connector to the AC IN connector and plug the other end into an AC outlet. Press the power switch to turn the power on.

Note:

- In order to protect this equipment and also other connected devices, make sure to turn off the power switch whenever you carry out connections.

STORING THE EQUIPMENT

1. Turn the power switch OFF, and then remove the power cord and the video cable from the terminals.

Note:

- Hold the plug sections of the power cord and the video cable when unplugging them from the terminals.

2. Rotate the camera head towards the direction of ① until you hear a click.

3. Press the lock release button ③ while moving the camera arm to the direction of ②. Then push down the camera arm towards the direction of ④. Release the lock release button and continue to push down the camera arm until you hear a click. Check and confirm that the camera arm is securely locked by trying to move it up and down slightly.

Note:

- Do not let go of the camera arm if it is not locked. Also hold the arm securely when pushing down the camera arm. Otherwise, the camera arm section will drop down of its own weight and this could result in breakdown and/or injury.
- If the camera arm is locked, do not apply extra force on the camera arm. This may result in breakdown.
- When storing, do not leave the equipment leaning against, for instance, a wall. The equipment may fall down causing breakdown and/or injury.
- When carrying around the equipment, make sure to hold it by the base section ⑤. Holding it by the camera arm or the lighting device will put too much strain on these parts. As a result the main unit may drop to the floor and cause breakdown or injury.

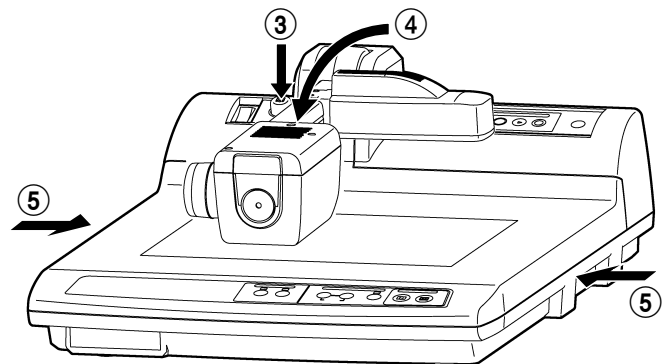
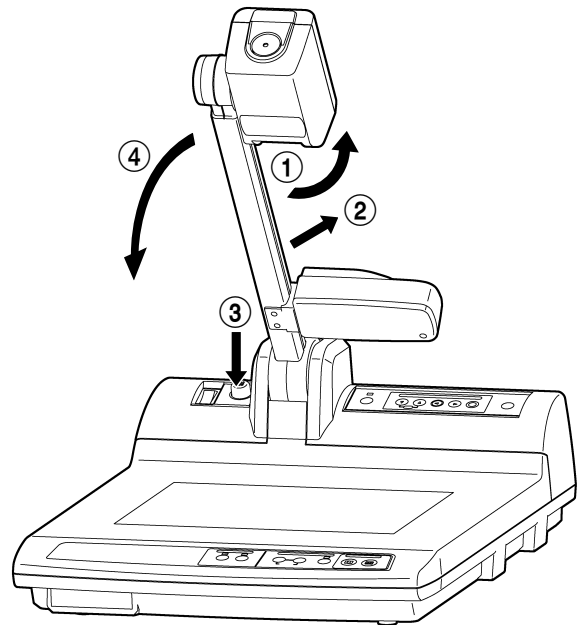

PRESENTATION

1. Presentation of Printed and Three-Dimensional Materials

- Place a subject on the stage, and adjust the subject size using the ZOOM button ① by looking at the monitor screen. (Focusing will be adjusted automatically.)
- * When using the equipment indoors, we recommend the use of lighting (see page 10 for lighting)

Note:

- The LIGHTING section will be hot while in use or immediately afterwards. Be careful not to touch it because it could cause burns.

2. Presentation of Slide Films

- Switch on lighting, insert a slide into the slide film holder ② and adjust the image size with the ZOOM button.
- Adjust the direction of lighting so that the stage will be at its brightest ③.
- Use the ZOOM at the WIDE setting. When the slide is a portrait, if you magnify it until the slide's frame is not visible, the image will be out of focus.

Note:

- Reflective light from the stage is used in this operation. Do not place any other materials on the stage.
- Depending on the slide, the image may become darker or acquire grittiness. In these cases, use a commercially available light box.

3. Filming peripheral subjects

When filming subjects such as faces or a blackboard that are not on the stage, remove the CLOSE-UP lens as shown in the diagram on the right of this page and then rotate the camera head towards the direction of ④.

Note:

- Avoid fingerprints or dust getting onto the close-up lens.
- When filming the subjects on the stage, the close-up lens needs to be fitted again. The camera head should be returned to the original position.

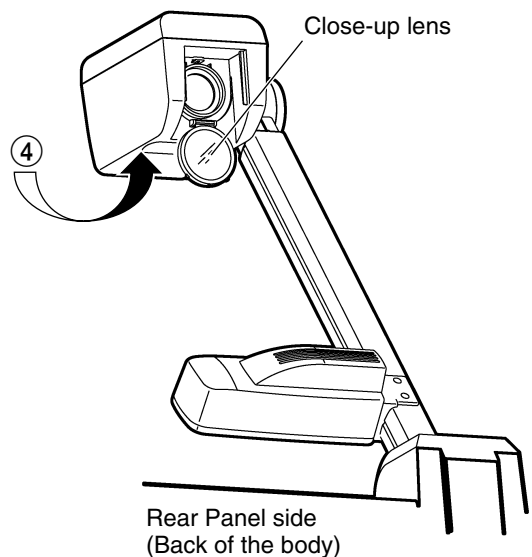
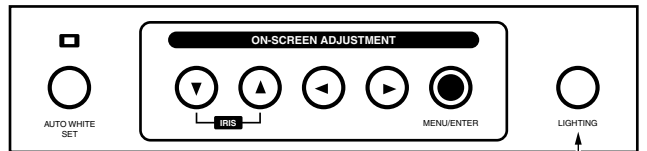
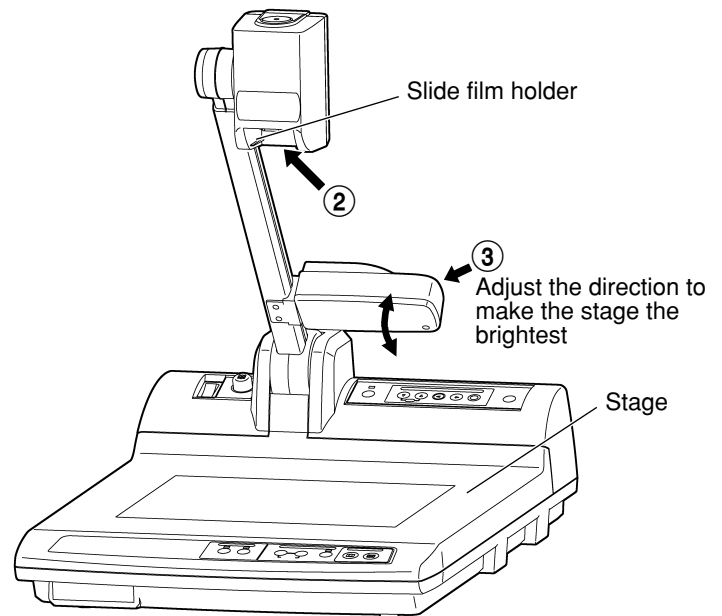
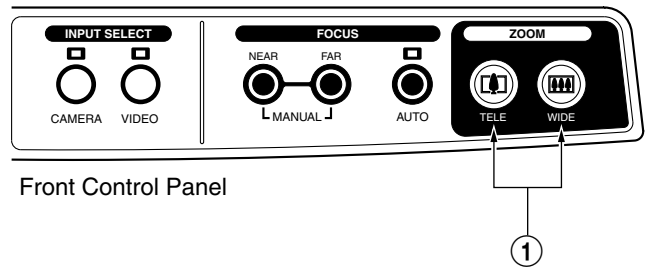

OPERATION

Zoom

- When the ZOOM button “TEL” is pressed, the image on the monitor screen will become gradually bigger; when the ZOOM button “WIDE” is pressed the image will become gradually smaller.
- Every time the ZOOM button is pressed, focusing will be automatically re-adjusted.
- When the ZOOM button is continually pressed, the zoom speed will increase after a while.

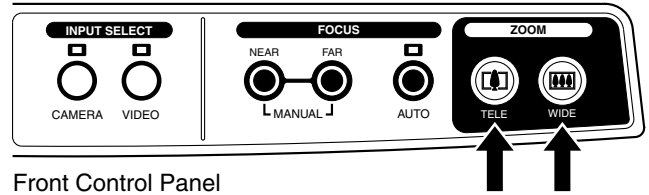

Front Control Panel

Focusing

AUTO FOCUSING

- When the AUTO button is pressed, focusing on the subject will be carried out automatically.
- Once auto focusing is completed, this particular function will be suspended and the focusing on the subject will remain constant. (The indicator lamp will blink while the auto focusing is in operation; once completed the lamp will remain lit for one second and then go out.)

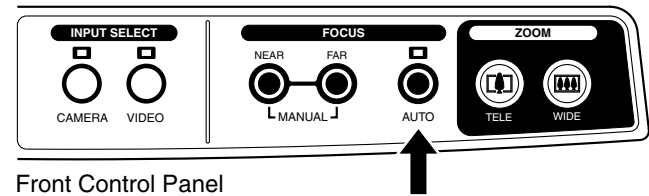

Front Control Panel

Note:

- Auto focusing may not work on the following subjects. If so, use manual focusing instead.
 - Subjects with minimal contrasts or shiny surfaces.
 - Subjects with detailed and repetitive patterns such as horizontal stripes, checked patterns, etc.
 - Three-dimensional or moving subjects
 - The subject is not centred on the screen.
 - The screen is dark.
- AUTO FOCUS will not operate while ‘ON SCREEN ADJUSTMENT’ is selected.

MANUAL FOCUSING

- When you wish to focus on a particular part of a three-dimensional object, adjust focusing by pressing the MANUAL FOCUS button.
- When the NEAR button of manual focusing is selected, focus will be on the higher part of the three-dimensional object; and when the FAR button is selected focus will be on the lower part of the three-dimensional object.

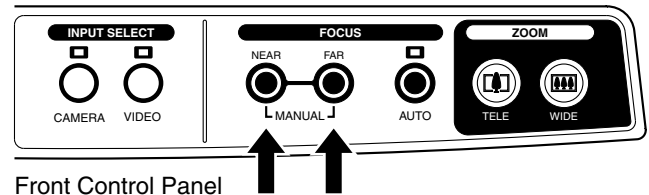

Front Control Panel

Input Select

- The INPUT SELECT button can change the signals of the main unit’s CAMERA IMAGE SIGNAL terminal and VIDEO INPUT terminal, and send them to the VIDEO OUTPUT terminal. Once selected, the indicator lamp will light up.
- When CAMERA is selected, image signals from the unit’s camera will be used.
- When VIDEO is selected, signals from the VIDEO INPUT terminal will be sent to the VIDEO OUTPUT terminal.

Note:

- Image signals from the VIDEO INPUT terminal cannot be sent to the CAMERA OUTPUT terminal.

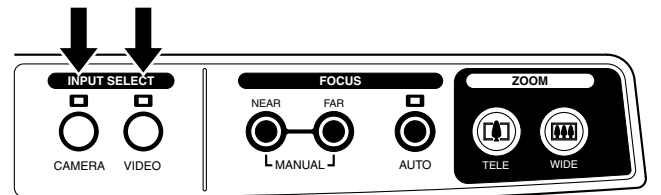

Front Control Panel

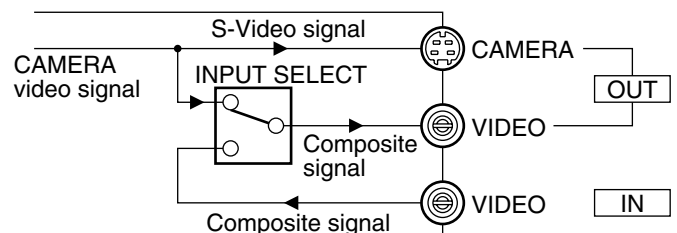

Lighting

- This button turns lighting ON/OFF.
- If you press this button while lighting is turned OFF, light will come on; if you push this button while lighting is turned ON, light will go out.

Note:

- Because a fluorescent lamp is used for lighting, it will take a few seconds to come on.

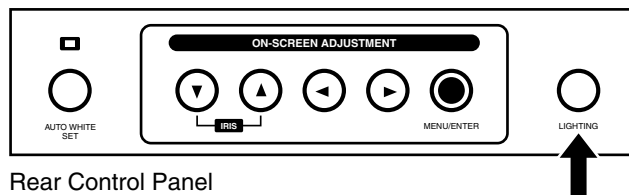

Brightness

- This function is used to adjust brightness of the material shown on the monitor screen.
- Adjustment is made with pressing the brightness adjustment buttons ▼ and ▲, and the level of adjustment can be confirmed with the values (+10 to -10) indicated at the upper right corner of the monitor screen. The initial setting is '0'.

Note:

- If brightness is lacking while IRIS is set at AUTO with the ON SCREEN ADJUSTMENT, the AUTO IRIS function may not start at all or take time before starting to operate.
- If you wish to fix the brightness, change the IRIS mode to MANUAL on the ON SCREEN ADJUSTMENT. (See page 11)

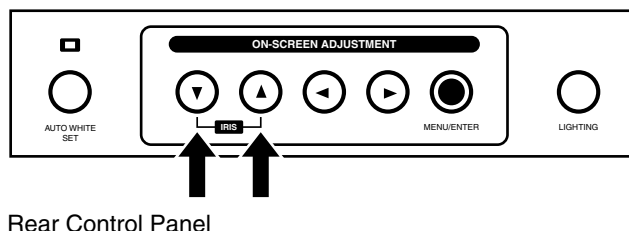

Auto White Set

- This function temporarily maintains the AUTO WHITE BALANCE adjustment. This will be particularly effective when filming a single color material.

[How to use AUTO WHITE SET]

- ① Press the AUTO WHITE SET button while filling the screen with colorless subject (e.g., the stage's white section).
- ② The indicator lamp will start blinking and the AUTO WHITE BALANCE adjustment will begin.
- ③ As soon as the AUTO WHITE BALANCE adjustment is completed, the indicator lamp will stop blinking and remain lit.
- ④ To return to the original setting, press the AUTO WHITE SET button. This will cancel the AUTO WHITE SET function and the indicator lamp will go out.

Note:

- Every time lighting on a subject changes, you must repeat the AUTO WHITE SET function.
- In order to adjust WHITE BALANCE manually set the WHITE BALANCE mode to MANUAL on the ON SCREEN ADJUSTMENT and then fine tune the balance using the RED LEVEL and the BLUE LEVEL.
- While the ON SCREEN ADJUSTMENT is shown on the monitor or the MANUAL setting is indicated, the AUTO WHITE SET button will not function.

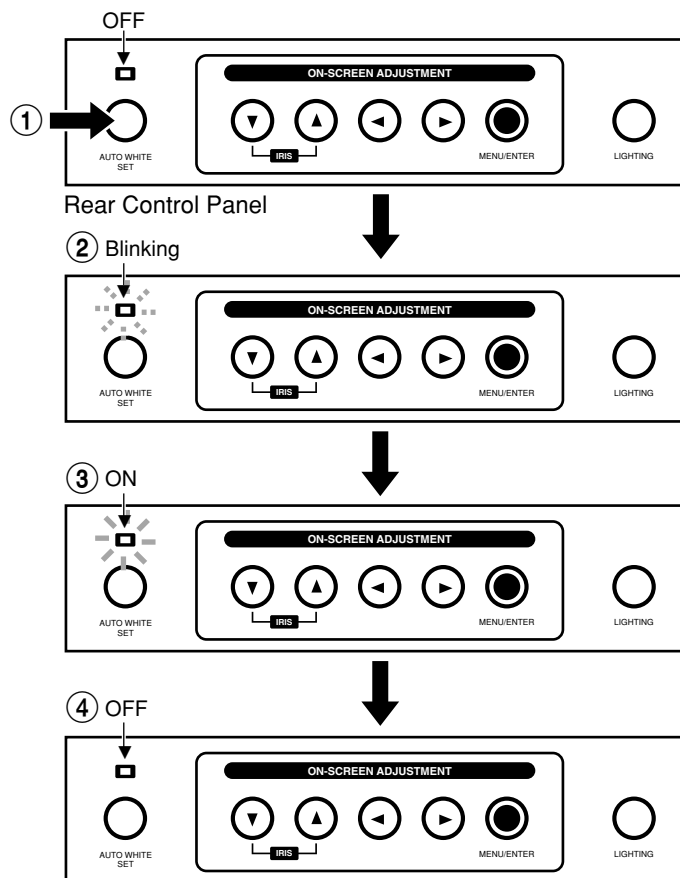

On-Screen Adjustments

This function will enable manual adjustment of the camera section and select settings such as NEG/POSI and/or BW/COLOR when presenting the negative film.

■ Operation Procedure

- The ON SCREEN Adjustment is performed using five different buttons : MENU/ENTER (5), ▼ button (1), ▲ button (2), ◀ button (3) and ▶ button (4).

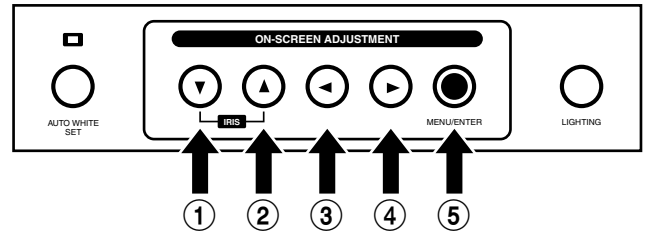

(Example) When changing screen brightness adjustment to MANUAL setting:

1. Press the MENU/ENTER button. The ON SCREEN ADJUSTMENT screen will appear on the monitor.

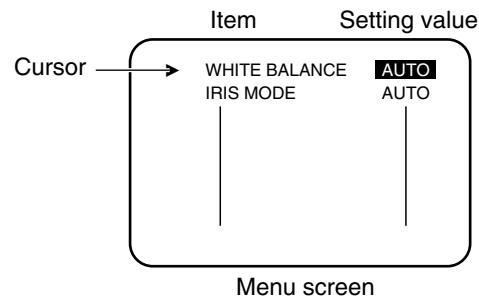

2. Line up the cursor with IRIS MODE by pressing the ▼ button (1), ▲ button (2).

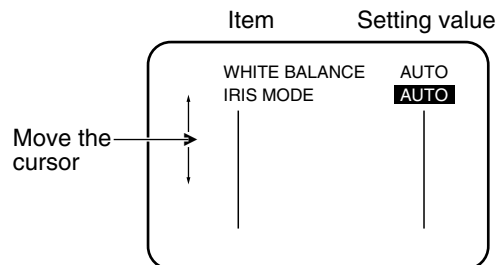

3. Change setting values using the ◀ button (3) and ▶ button (4).
Select MANUAL for setting value adjustment. At this point, the lowest line on the screen should be indicating the choices and variable range.

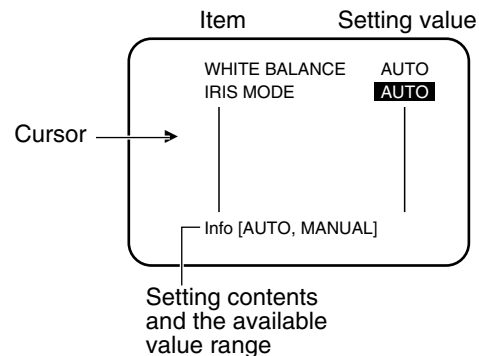

4. If the MENU/ENTER button (5) is pressed again, the ON SCREEN ADJUSTMENT screen will disappear from the monitor and the ON SCREEN ADJUSTMENT function will end.

■ Functions

Functions and setting values of the ON SCREEN ADJUSTMENT are as follows:

Item	Function	The Choices and Variable Range	Initial Value	
WHITE BALANCE MODE	AUTO : Automatically corrects tone of the image whenever the colour temperature changes in the environment where the equipment is used. MANUAL : Manually adjusts the image tone using the RED LEVEL and BLUE LEVEL.	AUTO, MANUAL	AUTO	
	RED LEVEL	If MANUAL is selected, the red level is adjusted.	-50 ~ +50	0
	BLUE LEVEL	If MANUAL is selected, the blue level is adjusted.	-50 ~ +50	0
IRIS MODE	AUTO : Automatically corrects brightness of the image whenever brightness of the surroundings and/or the subject changes. MANUAL : Fix the image brightness.	AUTO, MANUAL	AUTO	
	IRIS LEVEL	If AUTO is selected, finely adjusts brightness within $\pm F2$.	-10 ~ +10	0
		If MANUAL is selected, manually adjusts brightness.	-50 ~ +50	0
NEGA/POSI	Reverses tone and contrast of an image. This is used when presenting negative film.	POSI, NEGA	POSI	
BW/COLOR	BW : Creates B/W images. Use it with B/W text presentation, as it will enhance the sharpness of the image. COLOR : Creates color images.	COLOR, B/W	COLOR	
DETAIL	Modifies the contours of images.	NORMAL, SHARP, SOFT	NORMAL	
AGC	ON : Amplifies image level and automatically corrects brightness when used with little light. OFF : Is a normal setting.	OFF, ON	OFF	
GAMMA	ON : Is a normal setting. OFF : The monitor tone adjustment will not be modified. It is used when adjustments such as visual analysis are not necessary.	ON, OFF	ON	
SHUTTER	Changes shutter speed. If the shutter speed of 1/100 is selected, this reduces flickering of the screen by fluorescent lights in the 50Hz regions.	1/60, 1/100	1/60	

- If VIDEO is selected on the INPUT SELECT button, the ON SCREEN ADJUSTMENT cannot be used.
- Under normal circumstances, it is recommended to use the lighting device and keep the AGC turned off. The images on the monitor will be less gritty than those from the image signals that are electronically amplified.
- When the power is turned off, all settings go back to the initial values.
- When presenting negative film, please use a commercially available light box.

TROUBLE SHOOTING

Please check the following list of possible problems and their solutions first. If you cannot solve the problem(s) after consulting the list, stop using the product at once and contact your retailer or the nearest JVC customer service.

Problem	Check points
No images	<ul style="list-style-type: none"> • Check the power cord is properly plugged in. • Is the power switch ON? • Are all the cables correctly connected? • Is the camera head set at the correct position? • Is the setting value of IRIS LEVEL suitable? • Is the correct signal chosen by the INPUT SELECT button?
Images are out of focus.	<ul style="list-style-type: none"> • Is the close-up lens correctly attached? • Isn't the text material too close to the lens; is it placed more than 90mm above the stage? • Is the slide in the slide film holder over-magnified? • Auto focusing may at times cause difficulty in focusing. (See page 9)
Images are hazy. Dust is visible	<ul style="list-style-type: none"> • Check the close-up lens or camera lens for dirt. If so, clean them using commercially available lens cleaning products.
Dark images	<ul style="list-style-type: none"> • Is the lighting device turned on? • Is the setting value for IRIS suitable?
Stripe patterns appear on images of printed text.	<ul style="list-style-type: none"> • The halftone dot of printed text and the pixel of the microelectronics devices of the filmed images by the camera may interfere with each other to cause coloured stripes. In such a case, change the image size slightly using the ZOOM button.
Abnormal tone	<ul style="list-style-type: none"> • If AUTO WHITE BALANCE is used: in the case of single color materials it may be difficult to obtain correct white balance. If so, use the AUTO WHITE SET button to correct the tone. • If MANUAL WHITE BALANCE is used: correct the tone by increasing the setting values of 'RED LEVEL' and 'BLUE LEVEL' on the ON SCREEN ADJUSTMENT screen.
Gritty images	<ul style="list-style-type: none"> • If the surrounding area is dark, images may become gritty as the image signals are amplified electronically by AGC. Use the lighting device.
Beats appear in images	<ul style="list-style-type: none"> • If the equipment is used near any appliance that emits strong radio waves, beats may appear in the images. In that case, move the equipment away from the offending appliance.
Pressing buttons will not operate the equipment	<ul style="list-style-type: none"> • If two buttons are pressed at the same time or a button is tapped on continuously, they may not operate correctly. Press buttons one at a time.
Tinting around letter edges	<ul style="list-style-type: none"> • Depending on the materials you want to present, using the ZOOM function at its maximum or near maximum capacity may cause coloring around the edges of letters and lines in the materials. In that case the problem can be minimized by reducing the image size using the ZOOM WIDE button or changing the image to B/W. Use the ON SCREEN Adjustment function to change the image to B/W (See pages 11 & 12).

SPECIFICATIONS

GENERAL

Power supply	: AC100V – 120V, 50 Hz/60 Hz
Power consumption	: 17W
Dimensions	: During normal use: 450 × 605 × 585 mm (w/d/h) During storage : 450 × 605 × 230 mm (w/d/h)
Mass	: 5.9 kg

OPTICS SECTION

Photographic lens	: F1.6 ~ F2.6, f = 4.0mm ~ 64mm (×16)
Range	: Max. 350 × 260mm and over (equiva lent of B4 landscape) Min. 24 × 18mm and below
Focusing limit	: Stage surface to up to 90mm above the stage (with camera looking downwards and close-up lens in use) ~ 0.9 m (camera looking sideways and no close-up lens in use)
Size(zoom)	: Electric operation
Focus	: Automatic/electric operation
Iris	: Automatic(with fine adjustment)/ manual

LIGHTING SECTION

Light source	: 6W (fluorescent lamp)
--------------	-------------------------

CAMERA SECTION

TV system	: NTSC
Camera elemental device	: Interline transfer _ inch CCD
Active pixel number	: 768 (H) × 494 (V)
Synchronous system	: Internal synchronous
Horizontal resolution	: 450 TV standard (mainly Y-signals)
Vertical resolution	: 350 TV standard
S/N	: Over 46 dB
Electronic shutter	: 1/60, 1/100
White balance	: Auto/Auto White Set/Manual
AGC	: ON/OFF
Contour adjustmen	: Soft/Normal/Sharp
Gamma adjustment	: ON/OFF
Neg/Pos reversal	: Neg/Pos
BW/Colour reversal	: Colour/BW
Input selection	: Camera/Video

INPUT/OUTPUT TERMINALS

Input terminal :	
Video input	: RCA pin × 1 (1 Vp.p, 75 Ω)
Output terminals :	
Video output	: RCA pins × 1 (1 Vp.p, 75 Ω)
Camera output	: Mini DIN4 connector × 1 (1 Vp.p, 75 Ω), (C:0.3 Vp.p, 75 Ω)
Control terminal :	
Remote input	: D-SUB 9P (RS-232C) × 1

Operating environment

Temperature	: +5°C ~ +40°C
Humidity	: 30% ~ 85%

ACCESSORIES

Video cable (5 m)	× 1
Instruction manual	× 1
Power cord (2.5 m)	× 1

** Design and specifications are subject to change without notice.*

To reduce power consumption, turn off the power when not using the Presenter.

JVC[®]

VICTOR COMPANY OF JAPAN, LIMITED

JVC[®] is a registered Trademark owned by VICTOR COMPANY OF JAPAN, LTD.

JVC[®] is a registered Trademark in Japan, the U.S.A., the U.K. and many other countries.

© 2001 VICTOR COMPANY OF JAPAN, LIMITED

Download from Www.Somanuals.com. All Manuals Search And Download.



Printed in THAILAND
SS961572H-001

Free Manuals Download Website

<http://myh66.com>

<http://usermanuals.us>

<http://www.somanuals.com>

<http://www.4manuals.cc>

<http://www.manual-lib.com>

<http://www.404manual.com>

<http://www.luxmanual.com>

<http://aubethermostatmanual.com>

Golf course search by state

<http://golfingnear.com>

Email search by domain

<http://emailbydomain.com>

Auto manuals search

<http://auto.somanuals.com>

TV manuals search

<http://tv.somanuals.com>