



MICRO COMPONENT SYSTEM

UX-N1S

—Consists of CA-UXN1S and SP-UXN1S

UX-N1W

—Consists of CA-UXN1W and SP-UXN1W



INSTRUCTIONS

GNT0065-018A[US/UB/A/UW/UJ]
0306MOCMDWJSC

©2006 Victor Company of Japan, Limited

Warnings, Cautions and Others

Caution — button!

Disconnect the mains plug to shut the power off completely. When installing the apparatus, ensure that the plug is easily accessible.

- The button in any position does not disconnect the mains line. The power can be remote controlled.
- When the unit is on standby, the STANDBY lamp lights red.
- When the unit is turned on, the STANDBY lamp goes off.

CAUTION

To reduce the risk of electrical shocks, fire, etc.:
1. Do not remove screws, covers or cabinet.
2. Do not expose this appliance to rain or moisture.

CAUTION:

- Do not block the ventilation openings or holes. (If the ventilation openings or holes are blocked by a newspaper or cloth, etc., the heat may not be able to get out.)
- Do not place any naked flame sources, such as lighted candles, on the apparatus.
- When discarding batteries, environmental problems must be considered and local rules or laws governing the disposal of these batteries must be followed strictly.
- Do not expose this apparatus to rain, moisture, dripping or splashing and that no objects filled with liquids, such as vases, shall be placed on the apparatus.

Mains (AC) Line Instruction (not applicable for Europe, U.S.A., Canada, Australia, Hong Kong and U.K.)

Adjusting the voltage selector
Use a screwdriver to slide the voltage marker so that it is set to the same voltage as where you are plugging in the unit.

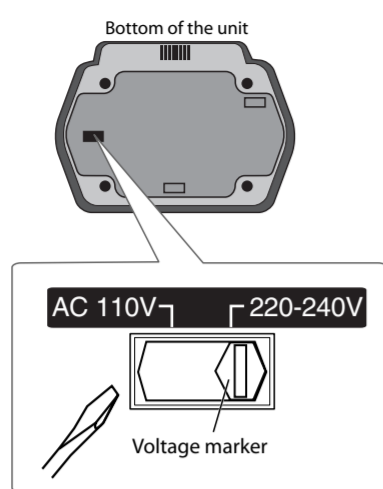

Caution for mains (AC) line

BEFORE PLUGGING IN, check that your mains (AC) line voltage corresponds with the position of the voltage selector switch on the bottom of the unit and, if different, set the voltage selector correctly to prevent any damage or risk of fire/electric shock.

CAUTION: DO NOT plug in before setting the voltage selector and all connection procedures are complete.

IMPORTANT FOR LASER PRODUCTS

- CLASS 1 LASER PRODUCT
- CAUTION:** Do not open the top cover. There are no user-serviceable parts inside the System; leave all servicing to qualified service personnel.
- CAUTION:** Visible and/or invisible class 1M laser radiation when open. Do not view directly with optical instruments.



CAUTION: Proper Ventilation

To avoid risk of electric shock and fire, and to prevent damage, locate the apparatus as follows:
1. Front: No obstructions and open spacing.
2. Sides/Top/Back: No obstructions should be placed in the areas shown by the dimensions below.
3. Bottom: Place on the level surface. Maintain an adequate air path for ventilation by placing on a stand with a height of 10 cm or more.

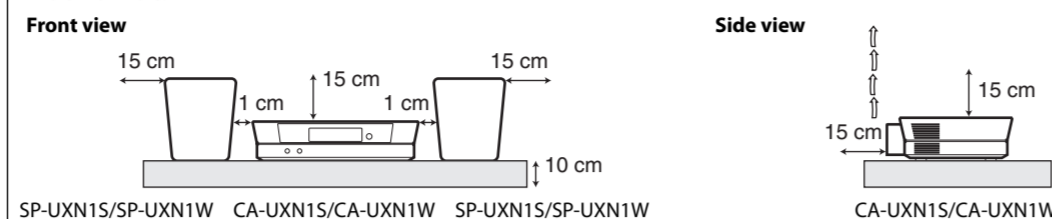

About the cooling fan
A cooling fan is mounted on the rear panel of the unit to prevent abnormal temperature inside the unit, thus assuring normal operation of the unit.

The model information is located on the bottom.

Precautions

Notes on the power cord

- When you are away on travel or otherwise for an extended period of time, remove the plug from the wall outlet. A small amount of power (5.0W) is always consumed while the power cord is connected to the wall outlet.
- When unplugging the System from the wall outlet, always pull the plug, not the power cord.
- Do not handle the power cord with wet hands.
- Disconnect the power cord before cleaning the System or moving the System.
- Do not alter, twist or pull the power cord, or put anything heavy on it, which may cause fire, electric shock, or other accidents.
- If the cord is damaged, consult a dealer and have the power cord replaced with a new one.

Avoid moisture, water, dust, and high temperatures

- Do not place the System in moist or dusty places.
- If water gets inside the System, turn off the power and remove the plug from the wall outlet, then consult your dealer. Using the System in this state may cause a fire or electrical shock.
- Do not expose the System to direct sunlight or place it near a heating device.

Notes on installation

- Select a place which is level, dry and neither too hot nor too cold between 5°C and 35°C.
- Do not install the System in a place subject to vibrations.
- Do not put heavy objects on the System.

To prevent malfunction or damage of the System

- Do not insert any metallic objects, such as wires, hairpins, coins, etc. into the System.
- Do not block the vents.

To clean the cabinet

- Use a soft cloth. Follow the relevant instructions on the use of chemically-coated cloths.
- Do not use benzene, thinner or other organic solvents and disinfectants. These may cause deformation or discoloring.

There are no user-serviceable parts inside. If anything goes wrong, unplug the power cord and consult your dealer.

Basic and Common Operations

Operating on the System

To	Press
Turn on or off (standby) the power	The STANDBY lamp on the System turns off/on.
Select a source*	See "Playing Back Discs" on page 4. See "Listening to FM and AM Broadcasts" on page 5. See "Connecting a Portable Audio Device" on page 6.
Adjust the volume	You can adjust the volume level from level 0 (VOL MIN) to level 31 (VOL MAX).

Using Headphones

Be sure to turn down the volume before connecting or wearing the headphones.
• Connecting the headphones will deactivate the speakers.

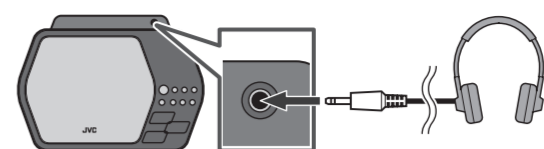

* You can operate the source select buttons on the System only touch lightly, because these buttons are "touch sensor panel." If you touch any one of these buttons, they lights in blue briefly.

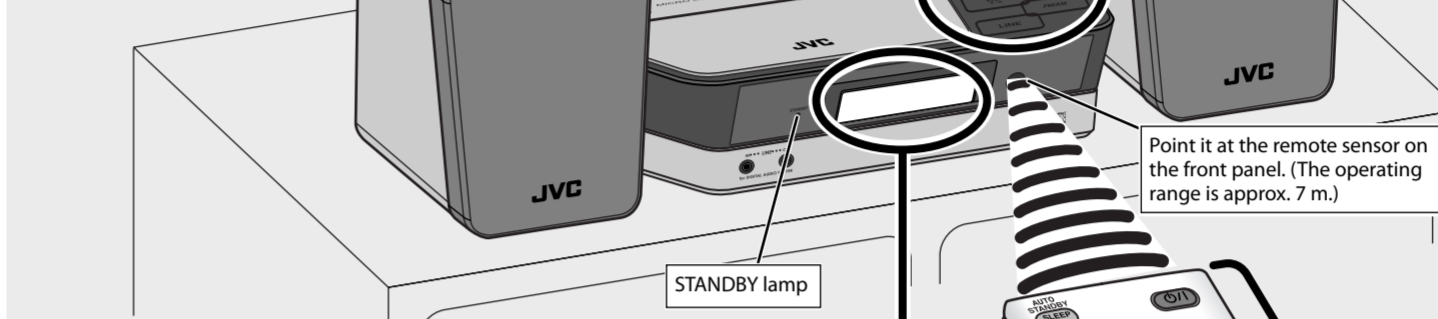

NOTE

DO NOT turn off (standby) the System with the volume set to an extremely high level; Otherwise, the sudden blast of sound can damage your hearing, speakers and/or headphones when you turn on the System or start playback.

Display Information

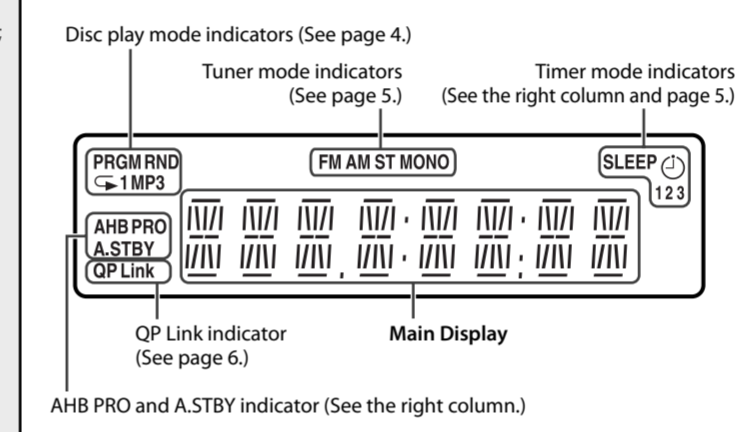

Operating on the Remote Control

To	Press
Turn on or off (standby) the power	The STANDBY lamp on the System turns off/on.
Select a source	See "Playing Back Discs" on page 4. See "Listening to FM and AM Broadcasts" on page 5. See "Connecting a Portable Audio Device" on page 6.
Adjust the volume	You can adjust the volume level from level 0 (VOL MIN) to level 31 (VOL MAX).
Drop the volume in a moment	To restore the volume, press again, or adjust the volume level.
Reinforce the bass sound	AHB PRO indicator appears on the display. To cancel this function, press again.
Adjust the tone (Bass/Treble)	Press once to adjust the bass level or press twice to adjust the treble level. Then press VOLUME + to increase the level or press VOLUME - to decrease it. • You can adjust the bass and treble level from -3 to +3.
Changing the display brightness	Press when the System is turned on. To cancel this function, press again.
Set the Save mode	Press and hold for more than 2 seconds when the System is on standby. To cancel this function, press and hold for more than 2 seconds again. • Setting the Save mode allows you to reduce power consumption by turning the display off while on standby.
Changing the display information (Clock and Source)	Press briefly (except for FM mode). For setting the clock, see page 5.
Turn off the System automatically after CD playback is over (AUTO STANDBY function)	Press and hold until ASTBY indicator appears on the display. To cancel this function, press and hold again. • If no operation is done for about 3 minutes after CD playback stops, the System turns off.
Turn off the System by using the sleep timer	Press briefly and repeatedly to specify the time (in minutes) as follows: 10 → 20 → 30 → 60 → 90 → 120 → 150 Canceled • To check the time remaining until the shut-off time after setting the sleep timer, press SLEEP once.

Getting Started

Supplied Accessories

After unpacking, check to be sure that you have all the following items. The number in parentheses indicates the quantity of each piece supplied.

- Remote control (x 1)
- Lithium coin battery CR2025 (x 1) (The battery has been installed when shipped from the factory.)
- AM loop antenna (x 1)
- FM antenna (x 1)
- AC plug adapter (x 1) (except for Hong Kong and Australia)

If anything is missing, consult your dealer immediately.

Prepare the Remote Control

When you use the remote control for the first time, pull out the insulation sheet.

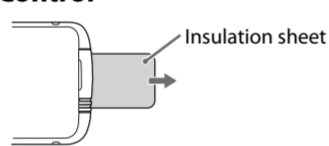

Replacing the Battery in the Remote Control

Insert the battery into the remote control by matching the polarity (+ and -) correctly.

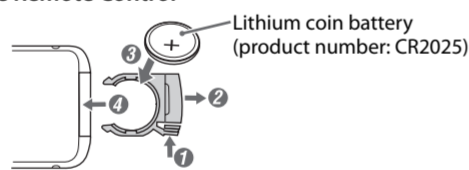

NOTES

- Store the battery in a place where children cannot reach. If a child accidentally swallows the battery, consult a doctor immediately.
- Do not recharge, short, disassemble or heat the battery or dispose of it in a fire. Doing any of these things may cause the battery to give off heat, crack, or start a fire.
- Do not leave the battery with other metallic materials. Doing this may cause the battery to give off heat, crack, or start a fire.
- When throwing away or saving the battery, wrap it in tape and insulate; otherwise, the battery may start to give off heat, crack, or start a fire.
- Do not poke the battery with tweezers or similar tools. Doing this may cause the battery to give off heat, crack, or start a fire.
- Dispose of battery in the proper manner, according to federal, state, and local regulations.

CAUTION: Danger of explosion if battery is incorrectly replaced. Replace only with the same or equivalent type.

Connections

Do not connect the AC power cord until all other connections have been made.

NOTES

- Make sure the antenna conductors do not touch any other terminals, connecting cords and power cord. Also, keep the antennas away from metallic parts of the System, connecting cords, and the AC power cord. This could cause poor reception.
- If the cords are covered with vinyl, remove the vinyl to expose the tip of the cord by twisting the vinyl.

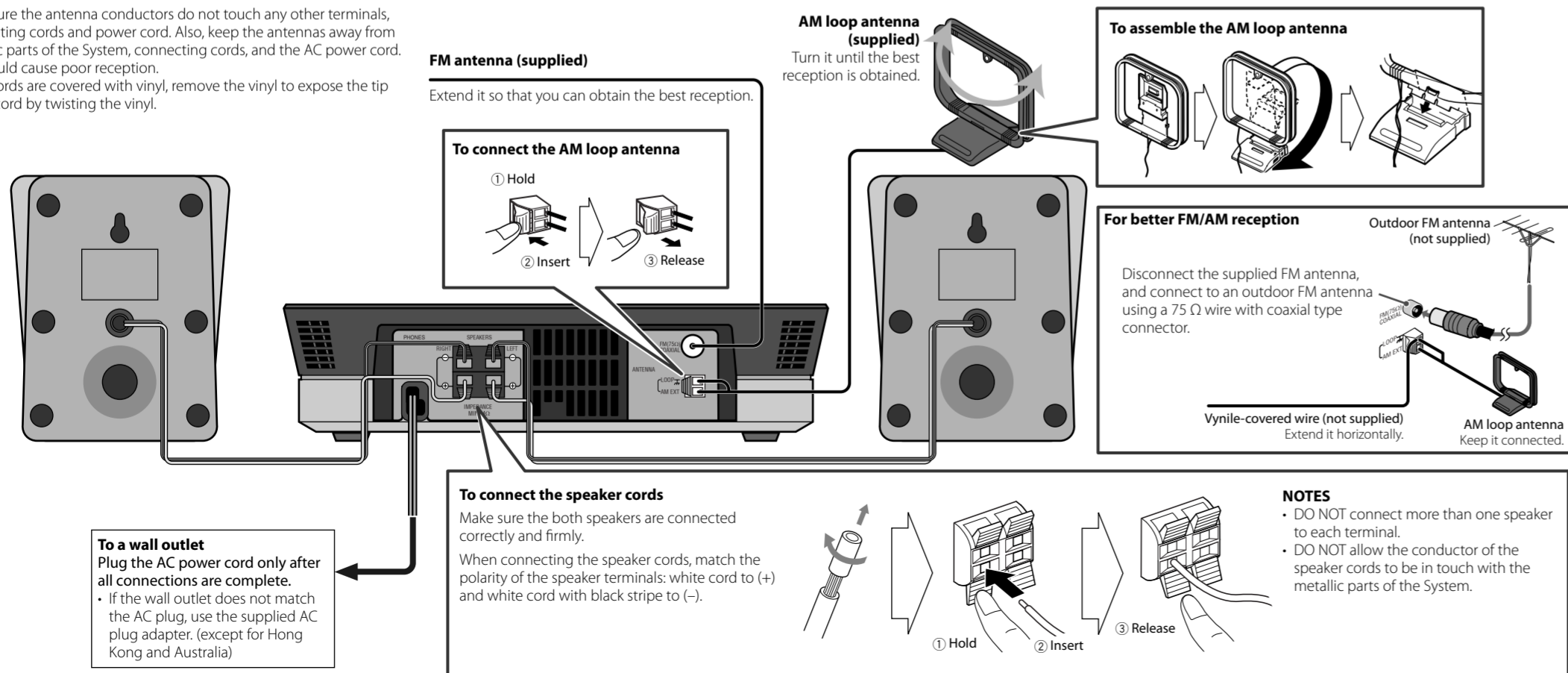

Playing Back Discs

This System can play back the following discs—regular CD and CD-R/CD-RW (recorded either in the audio CD or MP3 format).
• When playing back the MP3 track, MP3 indicator appears on the display.

To Set a Disc

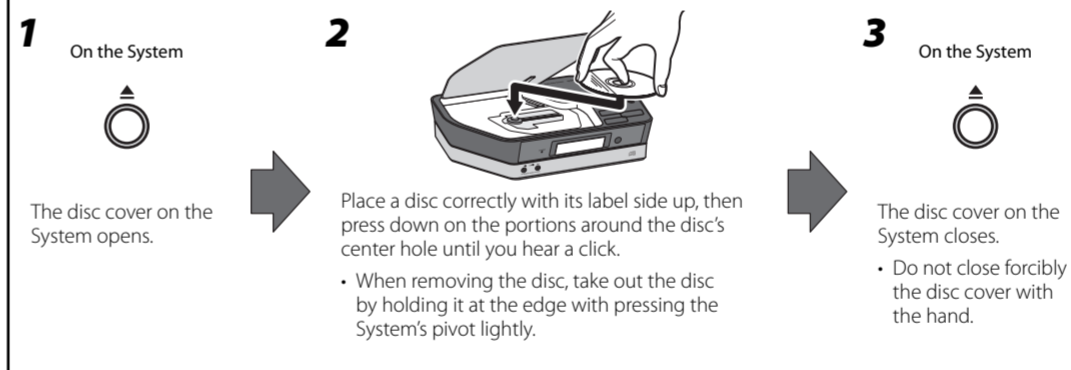

Basic Disc Operations

To	On the System	On the remote	Press
Playback the disc			Current track number and elapsed playing time appear on the main display. • During playback, press again to stop playing for a moment.
Stop playback			• While playback is stopped, total track number and total playing time (for MP3 disc, group number and track number) appear on the main display.
Select a track			Increases the track numbers. Decreases the track numbers.
Select a group (MP3 only)			Increases the group numbers while playback is stopped. Decreases the group numbers while playback is stopped.
Forward search / Reverse search			Fast-forwards the track by pressing briefly. To stop searching, press . Fast-reverses the track by pressing briefly. To stop searching, press .

NOTES

- If the disc cannot be read correctly (because it is scratched, for example) or an unreadable CD-R or CD-RW is loaded, playback will not start.
- If no disc is inserted, "NO DISC" appears on the main display.

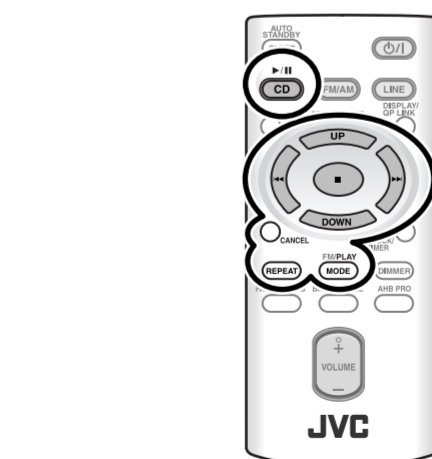

Playing Repeatedly—Repeat Play

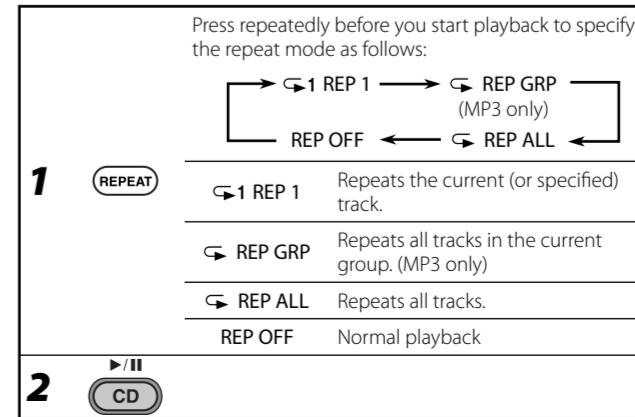

Programming the Playing Order—Program Play (except for MP3)

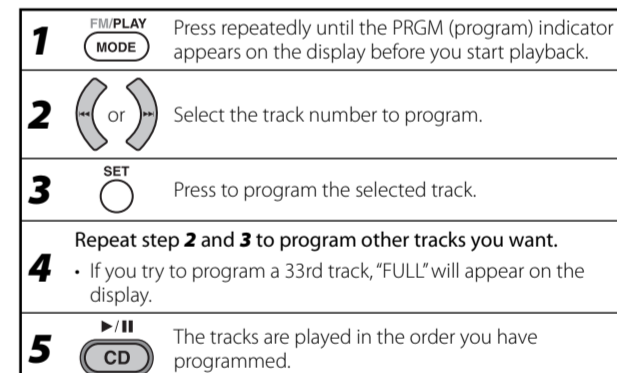

Operations on the Program Play Mode

To	Press
Check the programmed contents	Press while playback is stopped.
To erase the last step	
To erase the entire program	Press while playback is stopped.
To exit from program play	Press twice while playback is stopped to exit from the program play. • The stored program is erased.

Playing at Random—Random Play

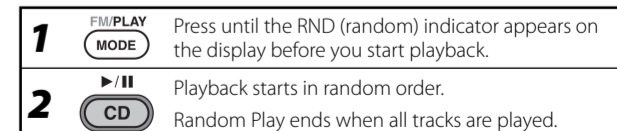

Operations on the Random Play Mode

To	Press
To skip a track	does not work.
To exit from random play	Press once while playback is stopped to exit from the random play.

Listening to FM and AM Broadcasts

Basic Tuner Operations

To	On the System	On the remote	Press
Set the AM tuner intervals to 9 kHz spacing	VOLUME +	—	Press and hold VOLUME +, then press when the System is on standby.
Set the AM tuner intervals to 10 kHz spacing	UP	—	Press and hold UP, then press when the System is on standby.
Select FM or AM			Each time you press the button, the band alternates between FM and AM. • "FM" or "AM" and selected frequency appear on the main display. • If an FM program is broadcast in stereo, the ST (stereo) indicator lights up on the display (only when the reception is good).
Select a frequency	DOWN UP	UP OR DOWN	Press and hold for more than 2 seconds. The System starts searching for stations and stops when a station of sufficient signal strength is tuned in. • Press during searching to stop. • Press repeatedly to change the frequency step by step.
Tune in to a preset station	—		Press to select a preset number for the station you store. • For presetting stations, see below.
Change the FM reception mode (When an FM stereo broadcast is hard to receive or noisy)	—		Press to improve reception. The MONO indicator appears on the display. Reception will improve though the stereo effect is lost. To restore the stereo effect, press again.

Presetting Stations

You can preset 30 FM and 15 AM stations manually.

1		Tune in to a station you want to preset. • You can also store the monaural reception mode for FM preset stations if selected.
2		Press to activate the preset number entry mode. • Finish the following process while the indication on the display is flashing.
3		Press to select a preset number for the station you store.
4		Press to store the station.

NOTE

When you unplug the AC power cord or if a power failure occurs, the preset stations will be erased in two days.



Setting the Clock and Daily Timer

Setting the Clock

Without setting the built-in clock, you cannot use Daily Timer and Sleep Timer.

1		Press to activate the clock setting mode. • If you have already adjusted the clock before, press the button repeatedly until the clock setting mode is selected.
2		Adjust the hour, then the minute.

- To exit from the clock setting, press CLOCK/TIMER as required.
- To go back to the previous step, press CANCEL.

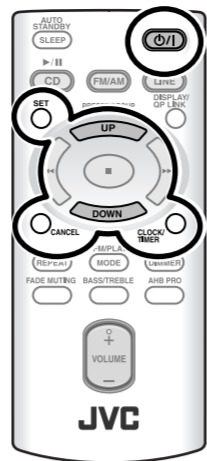

Setting the Daily Timer

- Using Daily Timer, you can wake up with your favorite music.
- You can store three Daily Timer settings; however, you can activate only one of Daily Timers at the same time.

1		Press repeatedly to select one of the timer setting modes you want to set—DAILY 1 ON time, DAILY 2 ON time, or DAILY 3 ON time—as follows: Daily 1 Timer → ON (Time) → Daily 2 Timer → ON (Time) → Daily 3 Timer → ON (Time) → Canceled → Clock setting (See above.) → ON (Time) → Daily 3 Timer
2		<ol style="list-style-type: none"> Adjust the hour then the minute for on-time. Adjust the hour then the minute for off-time. Select the playback source—"FM/AM," "CD," or "LINE." For "FM/AM": Select a preset channel. Select the volume level. For "LINE": Make the external device ready for playback. • You can select the volume level ("VOLUME 0" to "VOLUME 31" and "VOLUME --"). If you select "VOLUME --," the volume is set to the last level when the System is turned off.
3		Turn off the System (on standby).

- To exit from the timer setting, press CLOCK/TIMER as required.
- To correct a misentry during the process, press CANCEL. You can return to the previous step.

To turn off the Daily Timer

1		Press repeatedly to select "DAILY 1," "DAILY 2," or "DAILY 3."
2		

To turn on the Daily Timer again, select one of the timer settings by pressing CLOCK/TIMER, then press SET.

5

Learning More about This System

Basic and Common Operations (see page 3)

- Sound adjustments also affect the sound through the headphones.
- Sound adjustments do not affect recording to the external device.
- You can set the clock and daily timer while the Save mode is turned on. While setting the clock or daily timer, the display is turning on.

Playing Back Discs (see page 4)

- This System cannot play "packet write" discs.
- For MP3 playback...
 - MP3 discs are required a longer readout time than regular CDs. (It depends on the complexity of the group/file configuration.)
 - Some MP3 files cannot be played back and will be skipped. This result from their recording processes and conditions.
 - When making MP3 discs, use ISO 9660 Level 1 or Level 2 for the disc format.
 - This System can play back MP3 files with the extension code <.mp3> (regardless of the letter case—upper/lower).
 - It is recommended that you make each MP3 file at a sampling rate of 44.1 kHz and at bit rate of 128 kbps. This System cannot play back files made at bit rate of less than 64 kbps.
 - Playback order of MP3 tracks may be different from the one you have intended while recording. If a folder does not include MP3 tracks, they are ignored.
- This System can recognize up to 511 tracks in a disc. Also, the System can recognize up to 150 tracks per group and up to 99 groups in a disc. (for MP3)
 - If there are any unplayable files in a folder, those files are also counted in the total file number.
 - Playable files which do not belong to any groups are handled as Group 1.

MP3 groups/tracks configuration				
This System plays back MP3 tracks as follows.				
Hierarchy				
Level 1	Level 2	Level 3	Level 4	Level 5
ROOT	02	04	05	06
	03	10	01	08
		01	06	09
01	Group with its play order			
	MP3 track with its play order			

Maintenance

To get the best performance of the System, keep your discs and mechanism clean.

Handling discs

- Remove the disc from its case by holding it at the edge while pressing the center hole lightly.
- Do not touch the shiny surface of the disc, or bend the disc.
- Put the disc back in its case after use.
- Be careful not to scratch the surface of the disc when placing it back in its case.
- Avoid exposure to direct sunlight, temperature extremes, and moisture.

To clean the disc:

Wipe the disc with a soft cloth in a straight line from center to edge.

Connecting a Portable Audio Device (see page 6)

Playing back a portable audio device:

- If a component connected to the LINE IN jack is not loud enough, QP Link may not work properly. In such cases, adjust the volume level of the component louder so that the System can detect the sound signal properly.
- Changing from "LINE" to another source while QP Link works will deactivate QP Link temporarily. In this case, the following reactivates QP Link:
 - Pressing QP LINK on the remote control
 - When no sound signal comes from the LINE IN jack for about 30 seconds after the System is turned off
- If you press to turn the System off or if preset Timer turns the System off while QP Link works, the System deactivates QP Link temporarily. In such cases, the following reactivates QP Link:
 - When no sound signal comes from the LINE IN jack for about 30 seconds after the System is turned off
 - When you turn on the power again

Setting the Clock and Daily Timer (see page 5)

- "0:00" will flash on the display until you set the clock.
- The clock may gain or lose 1 to 2 minutes per month. If this happens, readjust the clock.
- When you unplug the AC power cord or if a power failure occurs, the clock and the timer will be canceled. You need to set the clock first, then the timer again.
- If you do not specify the preset station correctly while setting a timer, the currently selected station will be played when the timer is activated.
- When the on-time of the daily timer comes, the System sets the volume level gradually to the preset level after about 5 seconds.

Timer Priority:

- If you set the Sleep Timer after Daily Timer starts playing the selected source, Daily Timer is canceled.

Troubleshooting

If you are having a problem with your System, check this list for a possible solution before calling for service.

General

Power does not come on.

- Power plug is not inserted securely. Plug in securely.

Adjustments or settings are suddenly canceled before you finish.

- There is a time limit. Repeat the procedure again.

Operations are disabled.

- The built-in microprocessor may malfunction due to external electrical interference. Unplug the AC power cord and then plug it back in.

Unable to operate the System from the remote control.

- The path between the remote control and the remote sensor on the System is blocked.
- The batteries are exhausted.

No sound is heard.

- Speaker connections are incorrect or loose.
- Headphones are connected.

Radio Operations

Hard to listen to broadcasts because of noise.

- Antennas connections are incorrect or loose.
- The AM loop antenna is too close to the System.
- The FM antenna is not properly extended and positioned.

Disc Operations

The disc does not play.

- The disc is placed upside down. Place the disc with the label side up.
- MP3 disc is recorded with the "packet writing (UDF file)." It cannot be played. Check the files you want to play back.

ID3 Tag on an MP3 disc cannot be shown.

- There are two types of ID3 Tag—Version 1 and Version 2. This System can only show ID3 Tag Version 1.

MP3 groups and tracks are not played back as you expect.

- The playing order is determined when the disc was recorded. It depends on the writing application.

The disc sound is discontinuous.

- The disc is scratched or dirty.

The disc tray does not open or close.

- The AC power cord is not plugged in.

Timer Operations

Daily Timer does not work.

- The System has been turned on when the on-time comes. Timer starts working only when the System is turned off.

7

Connecting a Portable Audio Device

This System has LINE IN/OUT jacks to connect a portable audio device.

Connect between the device and the System by using the stereo mini plug cord (not supplied).

IMPORTANT:

It may be unlawful to record or play back copyrighted material without the consent of the copyright owner.

Playing back a portable audio device

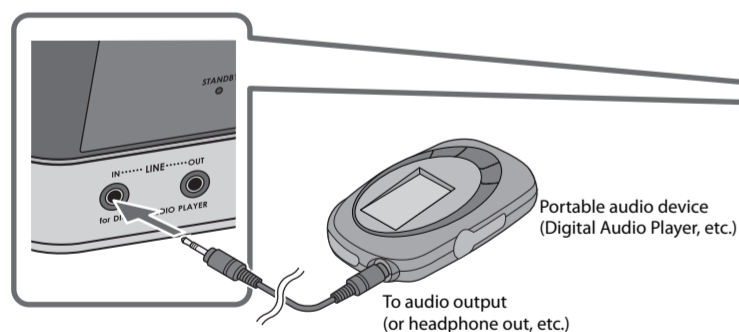

To audio output (or headphone out, etc.)

Portable audio device (Digital Audio Player, etc.)

1		"LINE" appears on the main display.
2		Start playing the device connected.
3		Adjust the volume level to the level you want to listen to.

To Adjust the Audio Input Level

If the sound from the device connected to the LINE IN jack is too loud or too quiet, you can change the audio input level through the LINE IN jack (without changing the volume level).

On the remote		Press and hold for more than 2 seconds while "LINE" is selected as a source. You can select one of three levels alternately.
---------------	--	--

To Play Back a Portable Audio Device Easily

By using QP Link (Quick Portable Link), you can easily start playing back a portable audio device connected to the LINE IN jack.

On the remote		Press and hold for more than 2 seconds to activate QP Link. QP Link indicator appears on the display. To cancel this function, press and hold for more than 2 seconds again.
---------------	--	--

When QP Link is activated, connecting a portable device to the LINE IN jack and starting playback performs the following:

- While listening to another source... Changes the source to "LINE" automatically. (If you change from "LINE" to another source, QP Link will be canceled.)
- While the System is on standby... Turns on the System and changes the source to "LINE" automatically (except when the display is turned off).

NOTE

See "Learning More about This System" on page 7.

6

Recording to a portable audio device

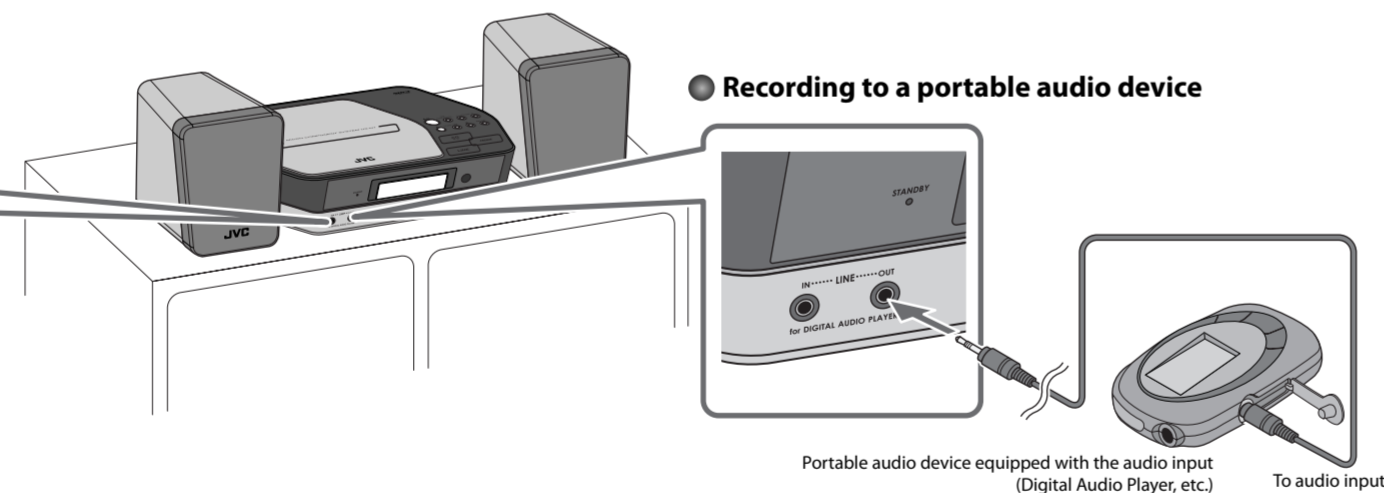

Portable audio device equipped with the audio input (Digital Audio Player, etc.)

To audio input

1		Start recording or standby recording on the device.
2	or	Start playing the CD or tune into the station you want to recording.

To Select the Audio Output Level

If the recorded sound on the device connected to the LINE OUT jack is too loud or too quiet, you can change the audio output level through the LINE OUT jack (without changing the volume level).

On the System		Press to change the audio output level. You can select one of two levels alternately as follows: OUT_LVL1 ↔ OUT_LVL2
---------------	--	---

8

Free Manuals Download Website

<http://myh66.com>

<http://usermanuals.us>

<http://www.somanuals.com>

<http://www.4manuals.cc>

<http://www.manual-lib.com>

<http://www.404manual.com>

<http://www.luxmanual.com>

<http://aubethermostatmanual.com>

Golf course search by state

<http://golfingnear.com>

Email search by domain

<http://emailbydomain.com>

Auto manuals search

<http://auto.somanuals.com>

TV manuals search

<http://tv.somanuals.com>