

JVC



AUDIO/VIDEO CONTROL RECEIVER

RECEPTOR DE CONTROL DE AUDIO/VÍDEO
RECEPTOR DE COMANDO AUDIO/VÍDEO
聲/視頻控制接收機

RX-774PBK

**TEXT
COMPU LINK**

**COMPU LINK
/// Remote ///**

**3D
3D-PHONIC**

DIGITAL AP

**DOLBY SURROUND
PRO • LOGIC**

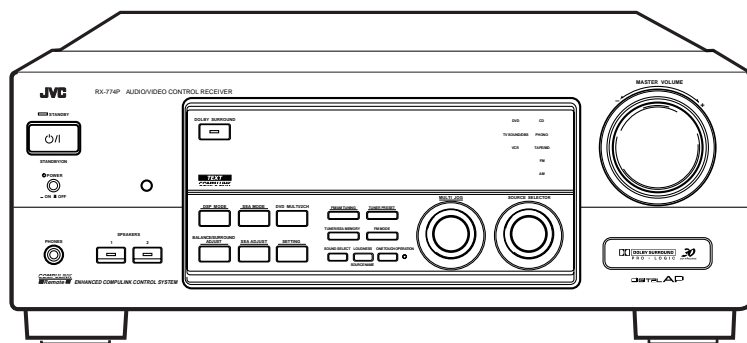
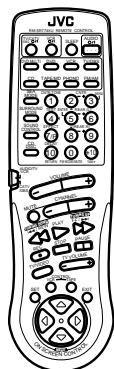

INSTRUCTIONS

MANUAL DE INSTRUCCIONES
INSTRUÇÕES
使用説明書

For Customer Use:

Enter below the Model No. and Serial No. which are located either on the rear, bottom or side of the cabinet. Retain this information for future reference.

Model No. _____

Serial No. _____

LVT0014-001A
[U, US]



Warnings, Cautions and Others / Avisos, precauciones y otras notas / Advertências, precauções e outras notas / 警告，注意及其他須知事項

تحذيرات، تنبيهات وأشياء أخرى

CAUTION

To reduce the risk of electrical shocks, fire, etc.:

1. Do not remove screws, covers or cabinet.
2. Do not expose this appliance to rain or moisture.

PRECAUCIÓN

Para reducir riesgos de choques eléctricos, incendio, etc.:

1. No extraiga los tornillos, los cubiertas ni la caja.
2. No exponga este aparato a la lluvia o a la humedad.

ATENÇÃO

Para reduzir riscos de choques eléctricos, incêndio, etc.:

1. Não retire parafusos nem desmonte as tampas ou o gabinete.
2. Não exponha este aparelho à chuva nem à umidade.

警告

為了減低觸電，火災等危險：

1. 請勿擅自卸下螺絲釘，蓋子或機殼。
2. 切勿讓本機受雨淋或置潮濕環境中。

تحذير

لتجنب خطر الحريق، الصدمات الكهربائية، الخ.:

1. لا تقم بفك البراغي، الاغطية أو الخزانات.
2. لا تقم بتعريض هذا الجهاز للمطر أو للرطوبة.

Caution — ① POWER switch and STANDBY/ON ①/I button!

This apparatus is provided with a ① POWER switch to be able to minimize power consumption for safe use. Therefore,

1. When doing initial setting, complete all the connections required, connect the mains plug into the wall outlet, and set the ① POWER switch to ON. After these, it will be available to operate STANDBY/ON ①/I button and so on.
2. When not in use, set the ① POWER switch to OFF.
3. Disconnect the mains plug to shut the power off completely. The ① POWER switch and STANDBY/ON ①/I button in any position do not disconnect the mains line.
4. The power can be remote controlled.

Precaución — Interruptor ① POWER y botón STANDBY/ON ①/I!

Esta unidad dispone de un interruptor ① POWER que sirve para reducir al mínimo el consumo de alimentación para proporcionar mayor seguridad operacional. Por lo tanto,

1. Al ejecutar el ajuste inicial, después de completar todas las conexiones requeridas, conectar el cable de alimentación a una toma de pared, y activar el interruptor ① POWER. Entonces, será posible ejecutar operaciones tales como la conmutación del estado de alimentación.
2. Desactivar el interruptor ① POWER al dejar la unidad fuera de uso.
3. Desconectar el cable de alimentación para desactivar la alimentación totalmente. Cualquier que sea la posición de ajustes del interruptor ① POWER y el botón STANDBY/ON ①/I, la alimentación no es cortada completamente.
4. La alimentación puede ser controlada remotamente.

Precaução — ① Interruptor POWER e botão STANDBY/ON ①/I!

Este aparelho dispõe de um interruptor ① POWER que possibilita reduzir ao mínimo o seu consumo de energia por medida de segurança. Assim,

1. Nos ajustes iniciais, efetue todas as conexões necessárias, ligue o plugue de alimentação à tomada e coloque o interruptor ① POWER em ON. Feito isso, será possível operar o botão STANDBY/ON ①/I e as diversas funções.
2. Quando não utilizar o aparelho, coloque o interruptor ① POWER em OFF.
3. Remova o plugue de alimentação da tomada para desligar o aparelho completamente. O interruptor ① POWER e o botão STANDBY/ON ①/I, em qualquer de suas posições, não desligam a alimentação do aparelho.
4. É possível controlar remotamente a função do interruptor POWER.

注意— ① POWER 開關及 STANDBY/ON ①/I 鍵！

本機備有 ① POWER 開關，能減少電能消耗，使用安全。因此：

1. 在開始設定時，確保完成所有必要的銜接，主電源插頭銜接至牆壁插座，並且把 ① POWER 開關置為 ON（開始）。之後，它便可操作 STANDBY/ON ①/I 鍵等等。
2. 不用本機時，把 ① POWER 開關置為 OFF（關閉）。
3. 若要完全切斷電源，必須把主電源插頭拔出。① POWER 開關和 STANDBY/ON ①/I 鍵的任何位置皆不能切斷主電源。
4. 遙控器可用來開關電源。

تحذير - مفتاح الطاقة الكهربائية POWER ① وزر الاستعداد للتشغيل/التشغيل ①/I STANDBY/ON!

هذا الجهاز مزود بمفتاح للطاقة الكهربائية POWER ① ليكون بالامكان تقليل استهلاك الطاقة الكهربائية وايضا من اجل سلامة الاستعمال. لذلك يرجى عمل ما يلي،

1. عند اجراء الضبط الاولي، اعمل كافة التوصيلات المطلوبة، اوصل قابس الطاقة الكهربائية مع فتحة مخرج الطاقة الكهربائية، ثم اضبط مفتاح الطاقة الكهربائية POWER ① على وضع التشغيل ON. بعد ذلك، سيكون بالامكان تشغيل زر الاستعداد للتشغيل/التشغيل ①/I STANDBY/ON وهكذا.
2. في حالة عدم استعمال الجهاز، اضبط مفتاح الطاقة الكهربائية POWER ① على وضع ايقاف التشغيل OFF.
3. انزع قابس الطاقة الكهربائية من اجل فصل الطاقة الكهربائية كلياً عن الجهاز. لا يفصل مفتاح الطاقة الكهربائية POWER ① وزر الاستعداد للتشغيل/التشغيل ①/I STANDBY/ON في اي وضع خط الطاقة الكهربائية الرئيسي عن الجهاز.
4. يمكن التحكم عن بعد بالطاقة الكهربائية.



Caution: Proper Ventilation

To avoid risk of electric shock and fire and to protect from damage.

Locate the apparatus as follows:

- Front: No obstructions open spacing.
Sides: No obstructions in 10 cm from the sides.
Top: No obstructions in 10 cm from the top.
Back: No obstructions in 15 cm from the back.
Bottom: No obstructions, place on the level surface.
In addition, maintain the best possible air circulation as illustrated.

Precaución: Ventilación Adecuada

Para evitar el riesgo de choque eléctrico e incendio y para proteger el aparato contra daños.

Ubique el aparato de la siguiente manera:

- Frente: Espacio abierto sin obstrucciones
Lados: 10 cm sin obstrucciones a los lados
Parte superior: 10 cm sin obstrucciones en la parte superior
Parte trasera: 15 cm sin obstrucciones en la parte trasera
Fondo: Sin obstrucciones, colóquelo sobre una superficie nivelada

Además, mantenga la mejor circulación de aire posible como se ilustra.

Precaução: ventilação apropriada

Para prevenir o risco de choque elétrico ou incêndio e para proteger o aparelho contra danos.

Localize-o da seguinte maneira:

- Frente: Espaço aberto, sem obstruções
Lados: Espaço de 10 cm sem obstruções nos lados
Topo: Espaço de 10 cm sem obstruções acima
Atrás: Espaço de 15 cm sem obstruções atrás
Parte inferior: Sem obstruções. Coloque o aparelho em superfície nivelada.

Mantenha, além disso, a maior circulação de ar possível, como indica a ilustração.

注意：正確的通風方法

為了防止觸電、火災以及避免損壞，

按如下要求放置機器：

- 前面：留下空間不要放置障礙物。
側面：側面的 10cm 之內不要放置障礙物。
上面：上面的 10cm 之內不要放置障礙物。
背面：背面的 15cm 之內不要放置障礙物。
底部：不要放置障礙物，水平放置。

此外，如圖所示，盡可能保持最佳的空氣循環。

تنبيه: حول التهوية الصحيحة

لتفادي وقوع الصدمة الكهربائية والحريق، ولحماية الأجهزة من التلف قم بتحديد مواقع تركيب الأجهزة كالتالي:

- الامام: مساحة فارغة بدون عوائق
الجوانب: عدم وجود أية عوائق بطول ١٠ سم من الجوانب
السطح العلوي: عدم وجود أية عوائق بطول ١٠ سم من السطح العلوي
الخلف: عدم وجود أية عوائق بطول ١٥ سم من اللوحة الخلفية
القاع: عدم وجود أية عوائق، يجب وضع الأجهزة على السطح المستوي.
بالإضافة الى ذلك، احتفظ بأفضل توزيع للهواء كما هو مبين في الرسم.

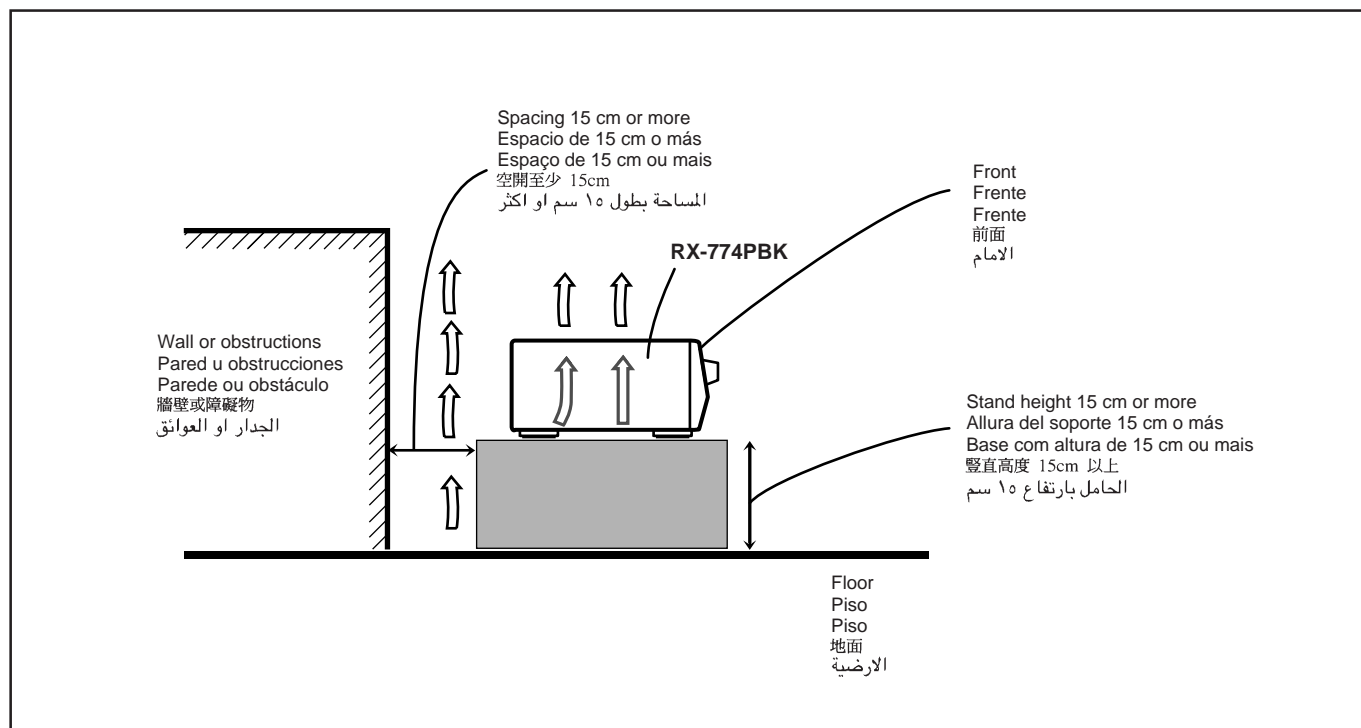

Table of Contents

Parts Identification	3
Easy Set Up & Operations	5
Getting Started.....	9
Before Installation.....	9
Checking the Supplied Accessories	9
Setting the Voltage Selector Switch	9
Connecting the FM and AM Antennas	10
Connecting the Speakers	11
Connecting Audio/Video Components	14
Connecting the Power Cord	19
Putting Batteries in the Remote Control	19
Basic Operations	20
Turning the Power On and Off (Standby)	20
Selecting the Source to Play	20
Adjusting the Volume	21
Selecting the Front Speakers	22
Muting the Sound	22
Recording a Source	22
Basic Settings	23
Changing the Source Name	23
Adjusting the Front Speaker Output Balance	23
Listening at Low Volume (Loudness)	23
Using the Sleep Timer.....	24
Setting Center and Rear Speakers for DSP Modes	24
One Touch Operation	26
About the One Touch Operation	26
Using the One Touch Operation.....	26
Receiving Radio Broadcasts	27
Setting the AM Tuner Interval Spacing	27
Tuning in Stations Manually	27
Using Preset Tuning	28
Selecting the FM Reception Mode	29
Assigning Names to Preset Stations	30
Using the SEA Modes	31
Selecting Your Favorite SEA Mode	31
Creating Your Own SEA Mode.....	32

Using the DSP Modes	33
Using the 3D-PHONIC Modes	34
Using the DAP Modes	36
Preparing for Surround Modes	39
Using Surround Modes	43
Using the DVD MULTI Playback Mode	44
Speaker Arrangements for DVD MULTI Playback	44
Activating the DVD MULTI Playback	44
Using the On-Screen Menus.....	47
Selecting the Source to Play	47
Selecting the Different Sources for Picture and Sound	47
Using the DSP Modes	47
Adjusting the Front Speaker Output Balance	48
Listening at Low Volume (Loudness)	48
Adjusting the DSP Modes	48
Selecting Your Favorite SEA Mode	49
Creating Your Own SEA Mode.....	50
Setting the Center Speaker Size	50
Setting the Rear Speaker	51
Setting the Delay Time	51
Operating the Tuner	51
Storing the Preset Stations	52
Assigning Names to the Preset Stations	52
COMPU LINK Remote Control System	54
TEXT COMPU LINK Remote Control System	55
Showing the Disc Information on the TV Screen	56
Searching a Disc (Only for the CD player).....	57
Using the User File (Only for the CD Player with the User File Function)	59
Entering the Disc Information	60
Operating JVC's Audio/Video Components	62
Operating Other Manufactures' Components	65
Troubleshooting	70
Specifications	71

Parts Identification

Become familiar with the buttons and controls on the receiver before use.

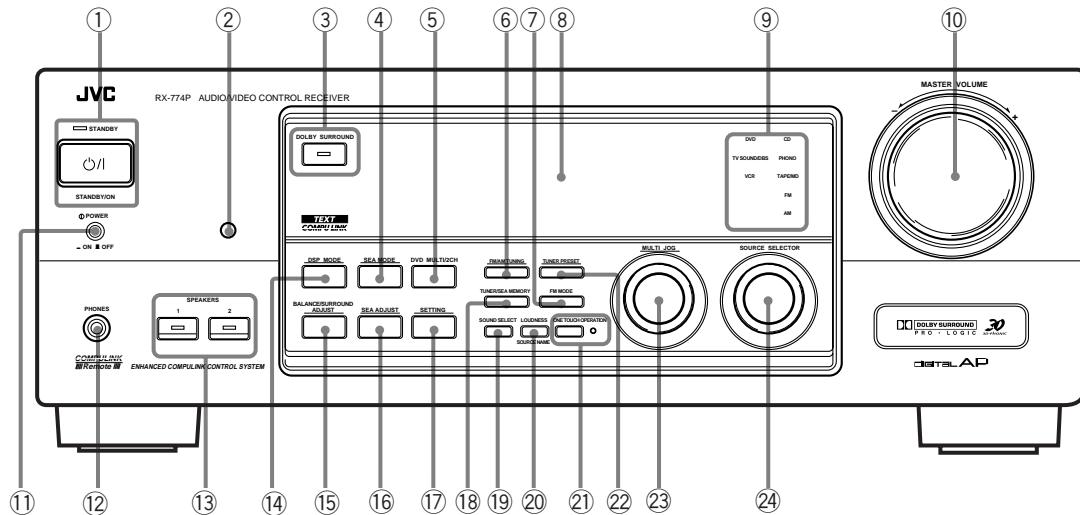

Refer to the pages in parentheses for details.

Front Panel

- | | |
|---|---|
| ① STANDBY/ON \cup/I button and STANDBY lamp (20) | ⑬ SPEAKERS 1/2 buttons and lamps (22) |
| ② Remote sensor (19) | ⑭ DSP MODE button (34) * |
| ③ DOLBY SURROUND button and lamp (41) | ⑮ BALANCE/SURROUND ADJUST button (23, 34) * |
| ④ SEA MODE button (31) * | ⑯ SEA ADJUST button (32) * |
| ⑤ DVD MULTI/2CH button (20) | ⑰ SETTING button (24) * |
| ⑥ FM/AM TUNING button (27) * | ⑱ TUNER/SEA MEMORY button (28, 32) |
| ⑦ FM MODE button (27, 29) | ⑲ SOUND SELECT button (21) |
| ⑧ Display (20) | ⑳ LOUDNESS/SOURCE NAME button (23) |
| ⑨ Source lamps (20) | ㉑ ONE TOUCH OPERATION button and lamp (26) |
| ⑩ MASTER VOLUME control (21) | ㉒ TUNER PRESET button (27, 28) * |
| ⑪ $\text{\textcircled{O}}$ POWER switch (19) | ㉓ MULTI JOG control (23) |
| ⑫ PHONES jack (22) | ㉔ SOURCE SELECTOR control (20) |

IMPORTANT:

To use the MULTI JOG control (㉓) on the front panel:

What this control actually does depends on which function you are trying to adjust. Before using this control, select the function by pressing one of the buttons marked with *.

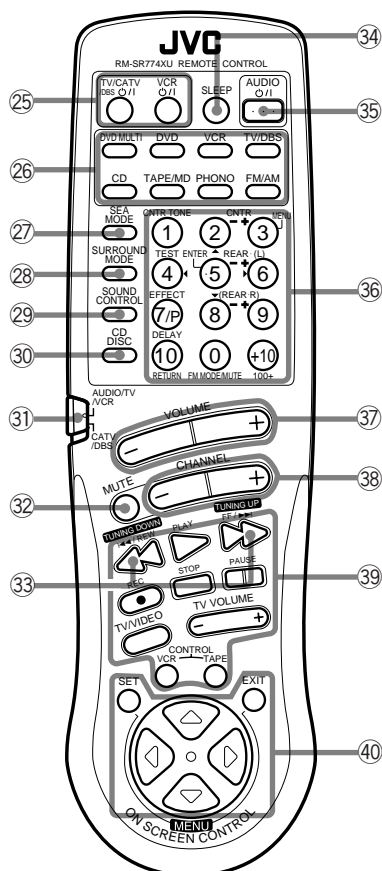

Refer to the pages in parentheses for details.

Remote Control

- ②5 TV/CATV/DBS \odot/I and VCR \odot/I buttons (65, 67)
- ②6 Source selecting buttons (21)
- ②7 SEA MODE button (31)
- ②8 SURROUND MODE button (35)
- ②9 SOUND CONTROL button (35, 38, 39, 46)
- ③0 CD DISC button (63)
- ③1 Remote control mode selector (AUDIO/TV/VCR, CATV/DBS) (20)
- ③2 MUTE button (22)
- ③3 TUNING UP/TUNING DOWN buttons (27)
Before using this control, make sure that you have pressed FM/AM button on the remote control.
- ③4 SLEEP button (24)
- ③5 AUDIO \odot/I button (20)
- ③6 10 keys for selecting preset channel (28)
10 keys for adjusting sound (35, 38, 39, 46)
10 keys for operating audio/video components (62, 65)
- ③7 VOLUME buttons (+/-) (21)
- ③8 CHANNEL buttons (+/-) (64)
- ③9 Operating buttons for audio/video components (62, 65)
- ④0 MENU operation buttons (SET, EXIT, Δ , ∇ , \triangleleft , \triangleright) (47)

IMPORTANT:

When using the remote control:

Check to see if its remote control mode selector (③1) is set to the correct position.

To operate an audio system, TV, and VCR, set it to “AUDIO/TV/VCR.”

To operate a CATV converter and DBS (Direct Broadcasting Satellite) tuner, set it to “CATV/DBS.”

Easy Set Up & Operations

If you are already familiar with audio components, following four pages just you opened give you enough information to operate your RX-774PBK for enjoyment of surround sound in your listening room.

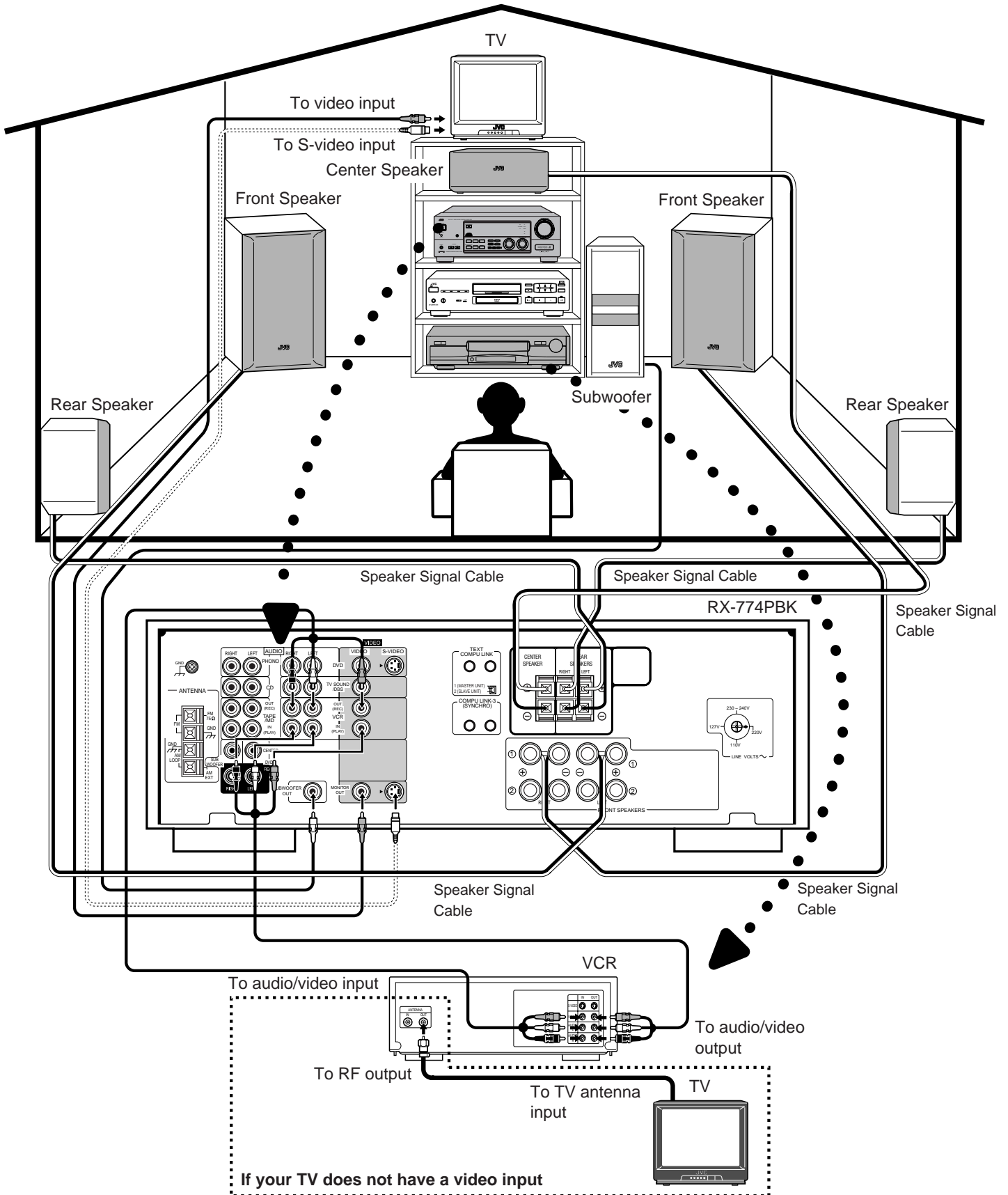

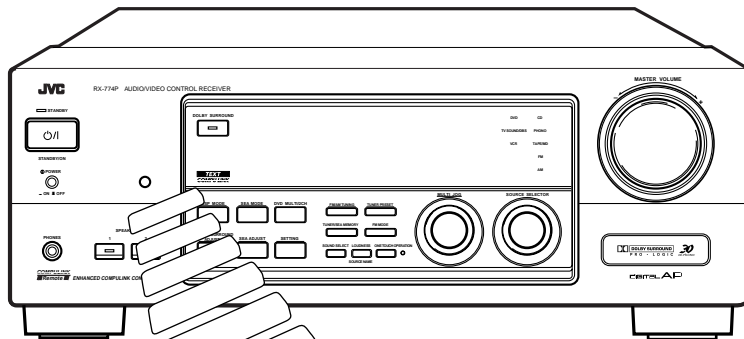

1. Turn on the power.



2. Select the source.

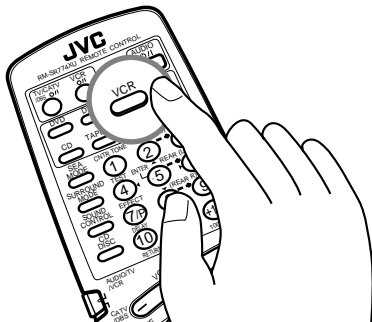

3. Adjust the volume.

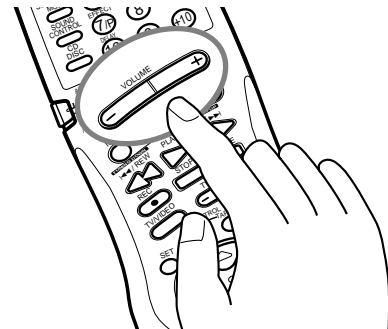

4. Select an appropriate DSP mode.



5. DSP mode settings are preset at the factory. However, if you need to make further adjustments, see pages 34 to 42.

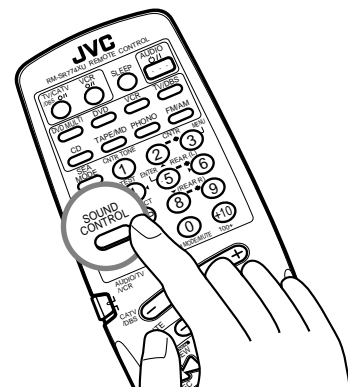

Easy Set Up & Operations

For Reproducing DVD MULTI playback with your DVD player

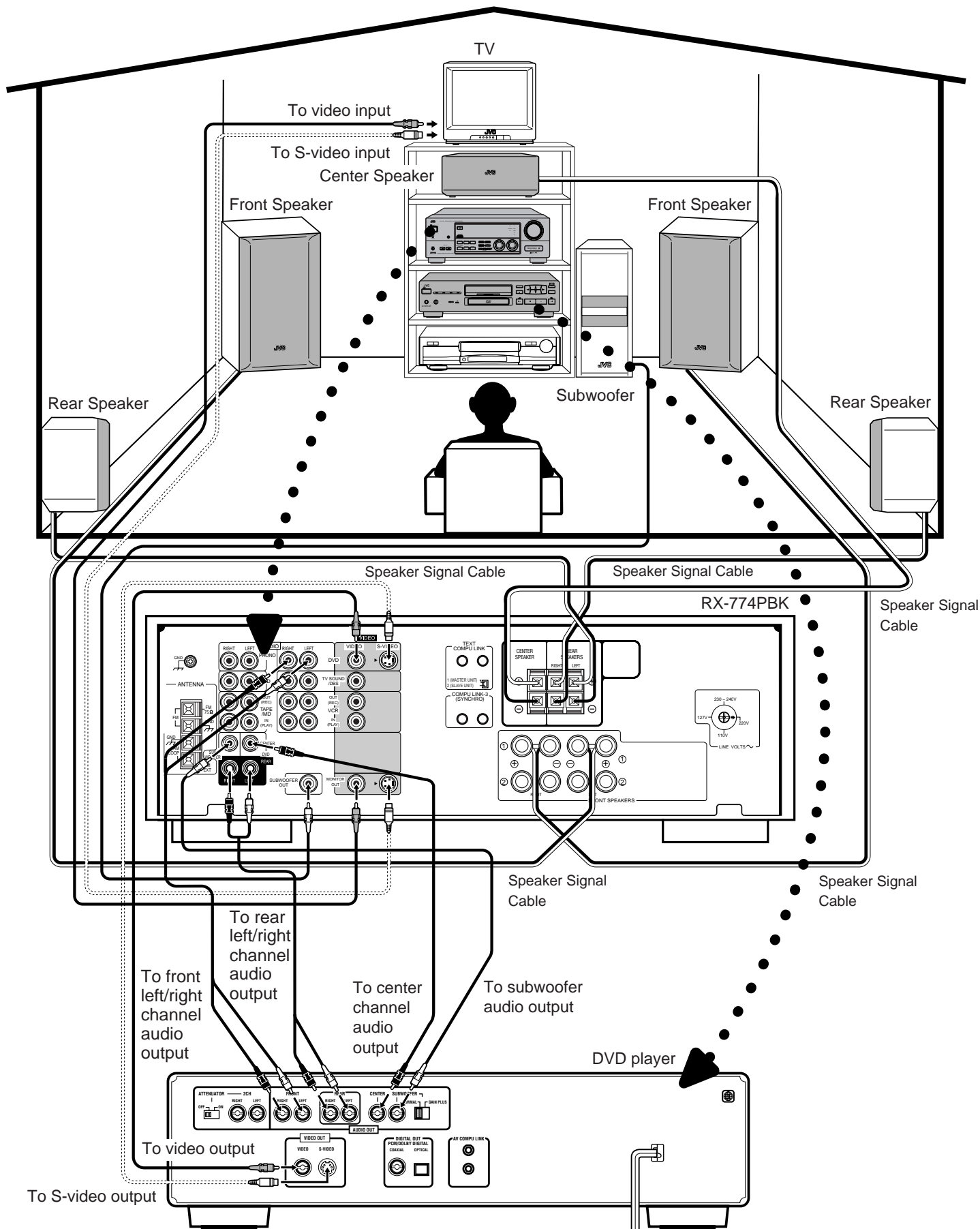

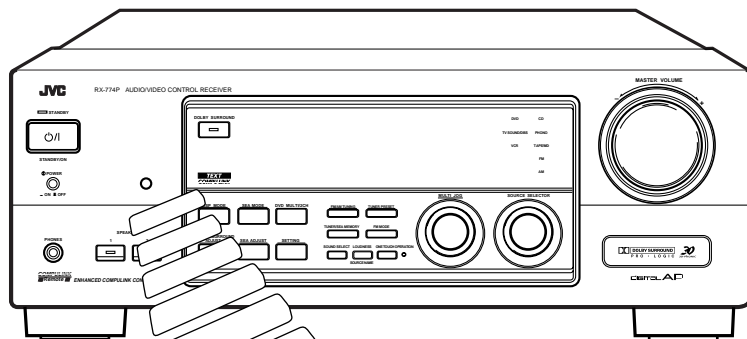

1. Turn on the power.



2. Select the source.

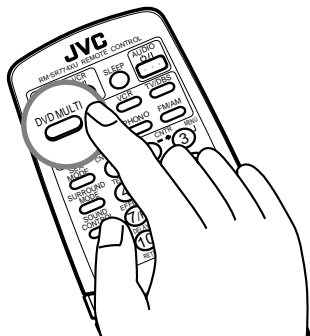

3. Adjust the volume.

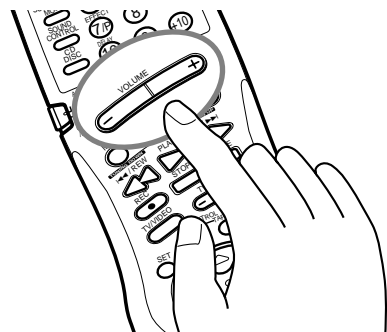

- 4. DVD MULTI playback settings are preset at the factory.**
However, if you need to make further adjustments, see pages 44 to 46.



Getting Started

This section explains how to connect audio/video components and speakers to the receiver, and how to connect the power supply.

Before Installation

General

- Be sure your hands are dry.
- Turn the power off to all components.
- Read the manuals supplied with the components you are going to connect.

Locations

- Install the receiver in a location that is level and protected from moisture.
- The temperature around the receiver must be between -5° and 35° C (23° and 95° F).
- Make sure there is good ventilation around the receiver. Poor ventilation could cause overheating and damage the receiver.

Handling the receiver

- Do not insert any metal object into the receiver.
- Do not disassemble the receiver or remove screws, covers, or cabinet.
- Do not expose the receiver to rain or moisture.

Checking the Supplied Accessories

Check to be sure you have all of the following items, which are supplied with the receiver.

The number in the parentheses indicates quantity of the pieces supplied.

- **Remote Control (1)**
- **Batteries (2)**
- **AM Loop Antenna (1)**
- **FM Antenna (1)**
- **Audio Signal Attenuating Cord (1)**
- **AC Plug Adaptor (1) (except for Peoples's Republic of China)**

If anything is missing, contact your dealer immediately.

Setting the Voltage Selector Switch

Before connections, always do the following first if necessary.

How to set the voltage selector:

Set the correct voltage for your area with the voltage selector switch on the rear panel. Use a screw driver to rotate the switch so the number the arrow is pointing at is the same as the voltage where you are plugging in the receiver.

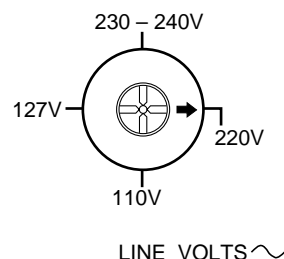

Connecting the FM and AM Antennas

FM Antenna Connections

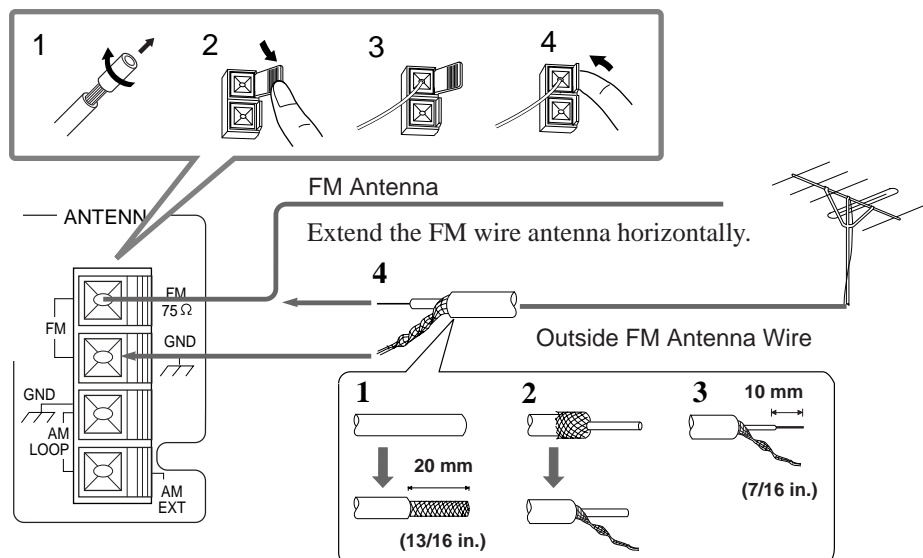

Note:

If reception is poor, connect the outside antenna. Before attaching a 75Ω coaxial cable (the kind with a round wire going to an outside antenna), disconnect the supplied FM wire antenna.

How to strip the 75Ω coaxial cable and connect it to the FM terminals

1. Strip back the outside covering of the 75Ω coaxial cable to expose the braided metallic mesh about 20 mm (13/16 inches).
2. Pull the mesh back and twist it into a single connector as shown in the illustration above.
3. Strip the insulation about 10 mm (7/16 inches) back from the central wire.
4. Insert the twisted mesh and the central wire to the FM terminals, as shown in the illustration above.

AM Antenna Connections

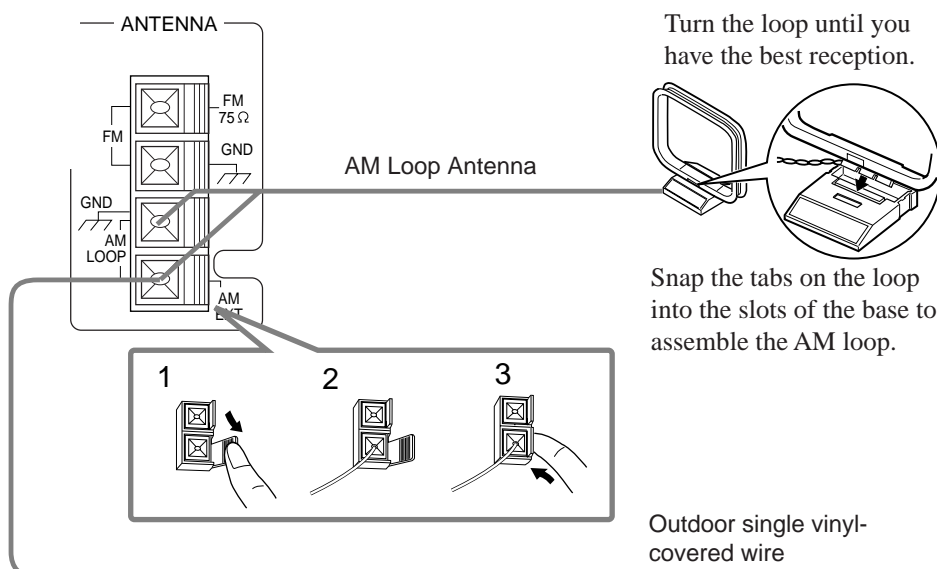

Notes:

- Make sure the antenna conductors do not touch any other terminals, connecting cords and power cord. This could cause poor reception.
- If reception is poor, connect an outdoor single vinyl-covered wire to the AM EXT terminal. (Keep the AM loop antenna connected.)

Getting Started

Connecting the Speakers

You can connect the following speakers:

- Two pairs of front speakers to produce normal stereo sound.
- One pair of rear speakers to enjoy the surround effect.
- One center speaker to produce more effective surround effect (to emphasize human voices).
- One subwoofer to enhance the bass.

IMPORTANT:

After connecting the speakers listed above, set the speaker setting information properly to obtain the best possible surround effect. For details, see page 24.

For each speaker (except for subwoofer), connect the (–) and (+) terminals on the rear panel to the (–) and (+) terminals marked on the speakers. For connecting a subwoofer, see page 12.

Connecting the front speakers

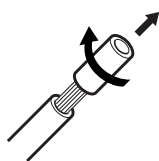

Cut, twist and remove the insulation at the end of each speaker signal cable first, and then, connect the front speakers to the FRONT SPEAKERS terminals by using the cables.

You can connect two pairs of front speakers (one pair to the FRONT SPEAKERS ① terminals, and another pair to the FRONT SPEAKERS ② terminals).

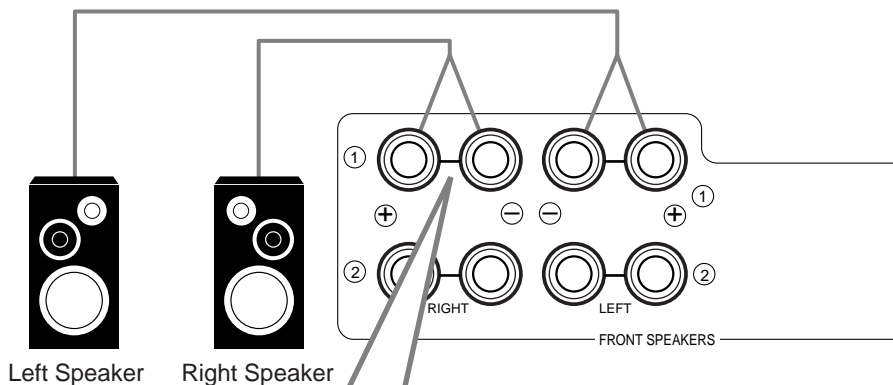

1 Turn the knob counterclockwise.

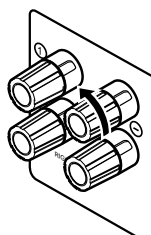

2 Insert the speaker signal cable.

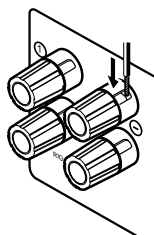

3 Turn the knob clockwise.

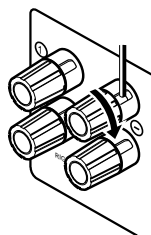

CAUTION:

Use speakers with the SPEAKER IMPEDANCE indicated by the speaker terminals.

Connecting the rear and center speakers

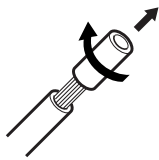

Cut, twist and remove the insulation at the end of each speaker signal cable first, and then, connect rear speakers to the REAR SPEAKERS terminals and a center speaker to the CENTER SPEAKER terminals by using the cables.

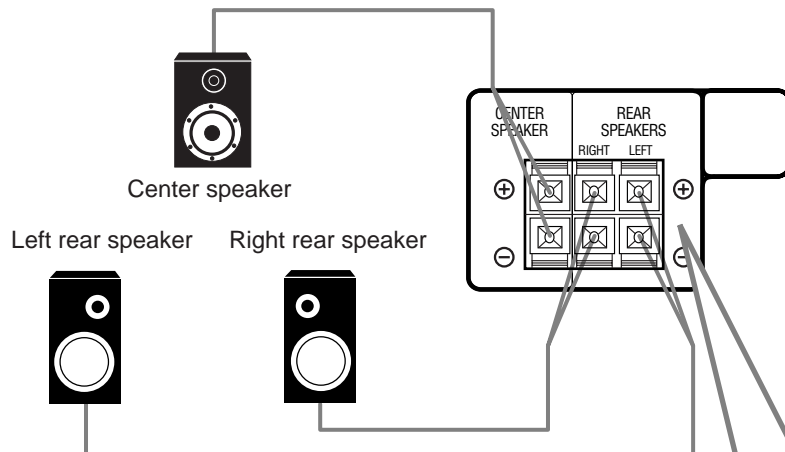

1 Open the terminal and then insert the speaker signal cable.

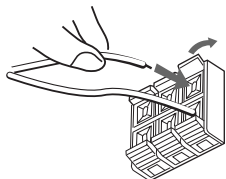

2 Close the terminal.

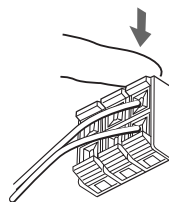

Connecting the subwoofer speaker

You can enhance the bass by connecting a subwoofer.

Connect the input jack of a powered subwoofer to the SUBWOOFER OUT jack on the rear panel, using a cable with RCA pin plugs.



Getting Started

About the speaker impedance

CASE 1 When you connect only one set of front speakers

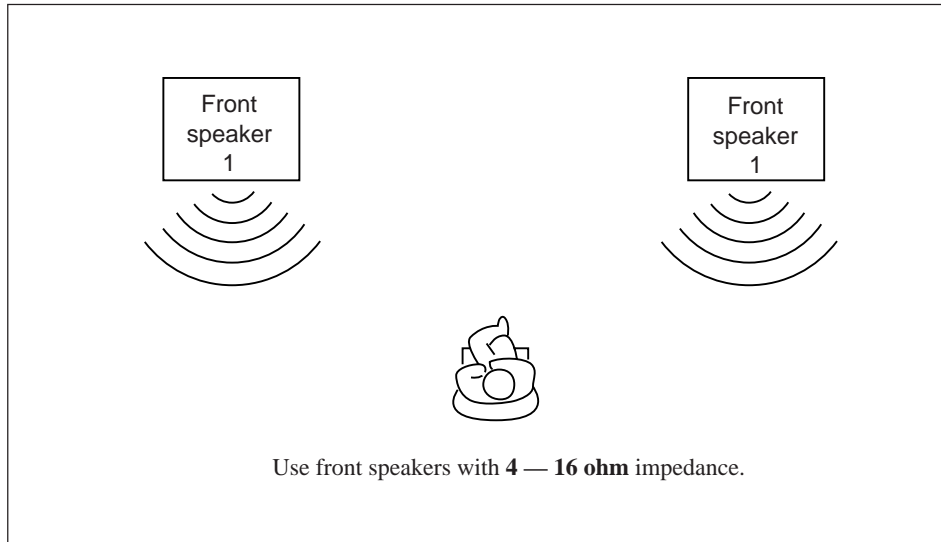

CASE 2 When you connect two sets of front speakers

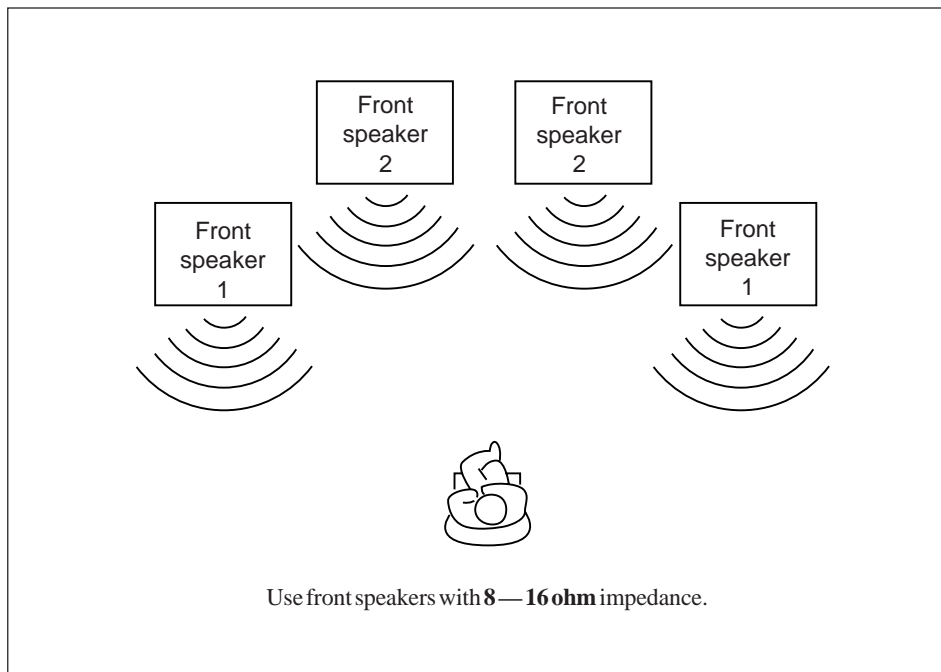

CAUTION:

When connecting speakers, use speakers with the same **SPEAKER IMPEDANCE** indicated by the speaker terminals.

Note:

The required speaker impedance of the front speakers does differ depending on whether both the **FRONT SPEAKERS ①** and **FRONT SPEAKERS ②** terminals are used or only one of them is used.

Connecting Audio/Video Components

You can connect the following audio/video components to this receiver using cables with RCA pin plugs (not supplied). Refer also to the manuals supplied with your components. If you want to connect a component not listed in the table below, refer to the manual supplied with it.

Audio Components	Video Components
• Turntable	• DVD (Digital Video Disc) player
• CD player	• TV
• Cassette deck (or MD recorder)	• DBS (Direct Broadcasting Satellite) tuner
	• VCR

Audio component connections

Use the cables with RCA pin plugs (not supplied).

Connect the white plug to the audio left jack, and the red plug to the audio right jack.

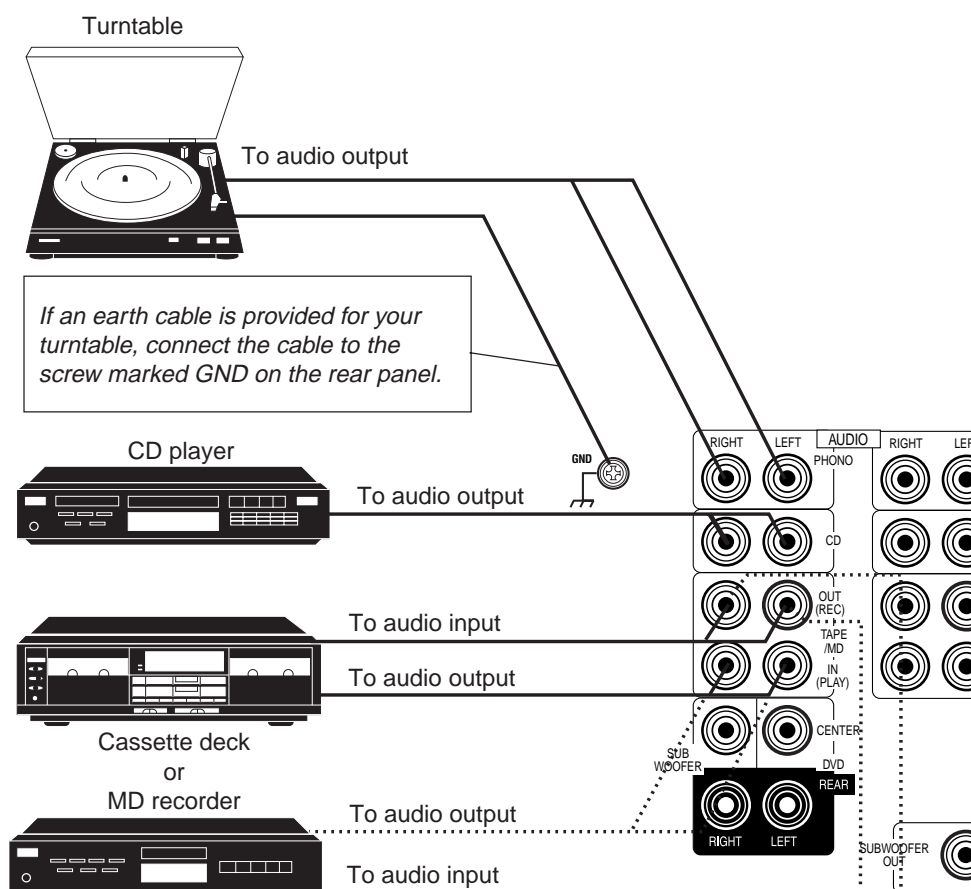

If your audio components have a COMPU LINK-3 or TEXT COMPU LINK terminal

- See also page 54 for detailed information about the connection and the COMPU LINK-3 remote control system.
- See also page 55 for detailed information about the connection and the TEXT COMPU LINK remote control system.

CAUTION:

If you connect a sound-enhancing device such as a graphic equalizer between the source components and this receiver, the sound output through this receiver may be distorted.

Notes:

- Any turntables incorporating a small-output cartridge such as an MC (moving-coil type) must be connected to this receiver through a commercial head amplifier or step-up transformer. Direct connection may result in insufficient volume.
- You can connect either a cassette deck or an MD recorder to the TAPE/MD jacks. When connecting an MD recorder to the TAPE/MD jacks, change the source name, which will be shown on the display when selected as the source, to "MD." See page 23 for details.
- When connecting an audio/video component (ex.: Video CD player) with "karaoke" — singing along — function, use the audio signal attenuating cord **supplied with this receiver**. If not, sound may be distorted.

Getting Started

Video component connections

Use the cables with RCA pin plugs (not supplied).

Connect the white plug to the audio left jack, the red plug to the audio right jack, and the yellow plug to the video jack.

If DVD player and TV have S-video (Y/C-separation) terminals, connect them using S-video cables (not supplied). Connecting these video components through the S-video input/output terminals will give you better picture playback quality.

IMPORTANT:

This receiver is equipped with both the composite video and S-video input terminals for the DVD player connection.

You do not have to connect both the composite video and S-video terminals.

However, **remember that the video signals from the composite video input terminal are output only through the composite video output terminals, while the ones from the S-video input terminal are output only through the S-video output terminal.**

Therefore, if your DVD player is connected to the receiver only through the S-video input terminal, you cannot record the picture from the DVD player on the VCR.

In addition, if the TV and the DVD player are connected to the receiver through the different video terminals, you cannot view the playback picture from the DVD player on the TV.

Note:

When connecting an audio/video component (ex.: Video CD player) with "karaoke" — singing along — function, use the audio signal attenuating cord **supplied with this receiver**. If not, sound may be distorted.

TV connection (as the monitor)

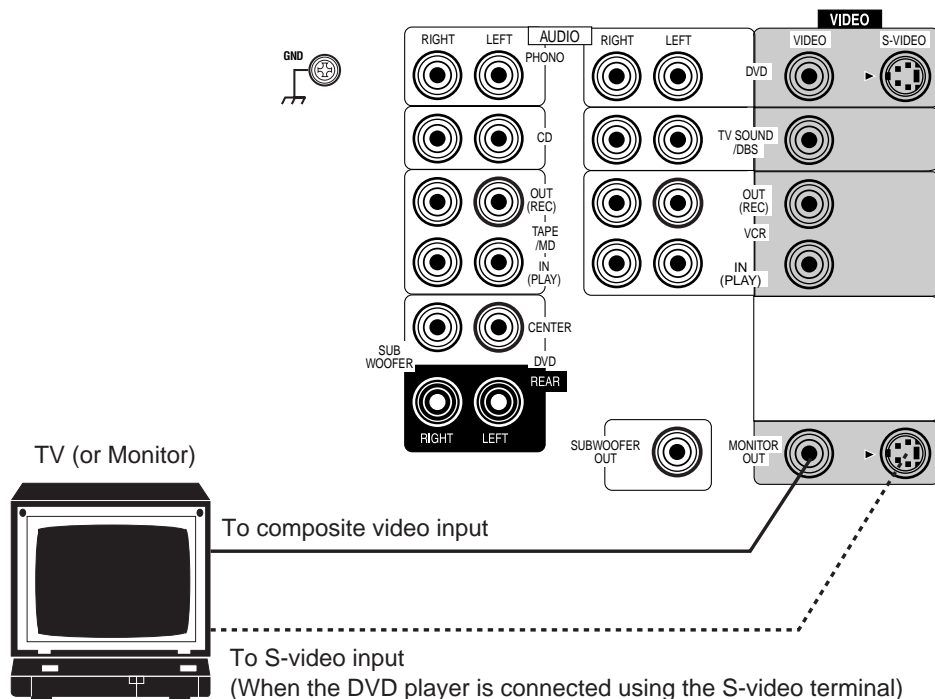

Note:

Use the video components of the PAL color system.

DVD player connection

- When you connect the DVD player with stereo output jacks:

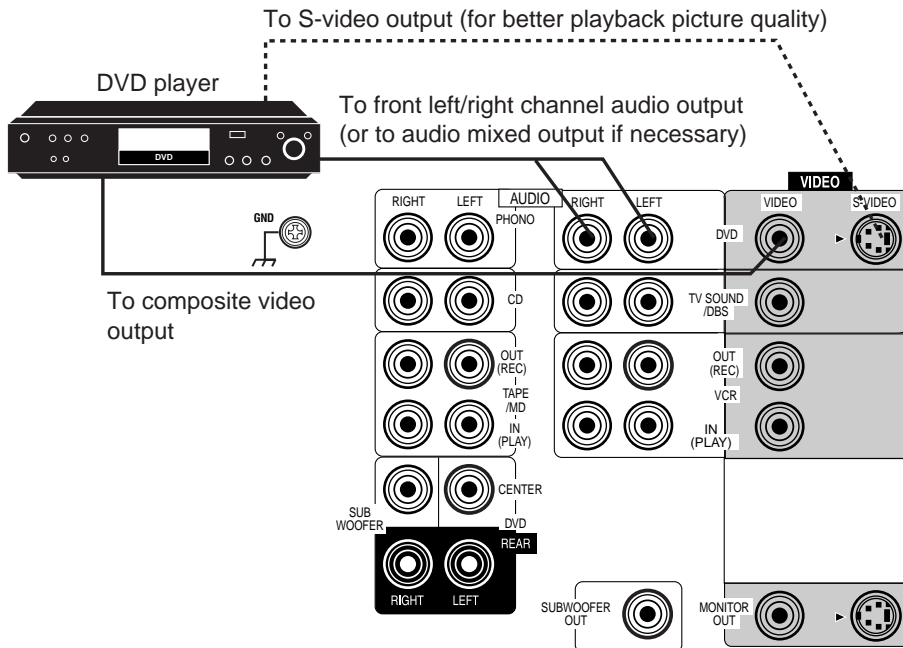

- When you connect the DVD player with its analog discrete output (5.1 CH reproduction) jacks:

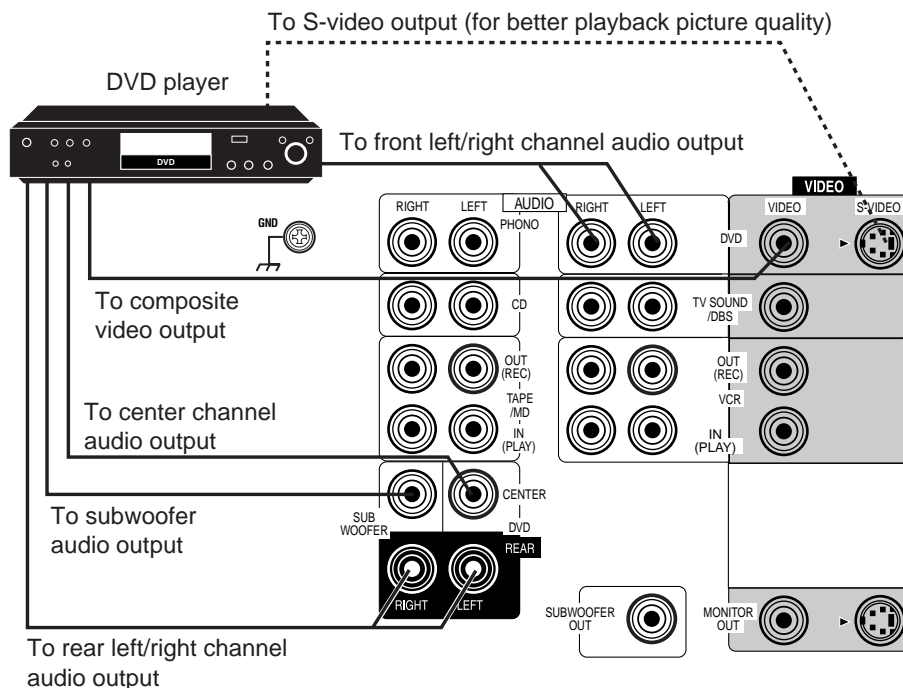

Getting Started

TV (as the sound source) or DBS tuner connection

You can connect either the TV or DBS tuner to the TV SOUND/DBS jacks.

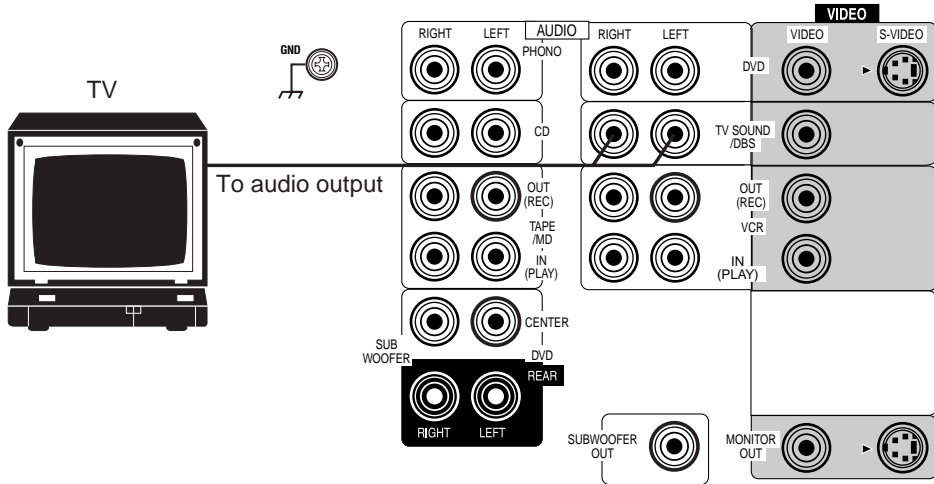

Note:

When connecting the TV to the TV SOUND/DBS jacks, DO NOT connect the TV's video output to the video input terminal of the TV SOUND/DBS jacks.

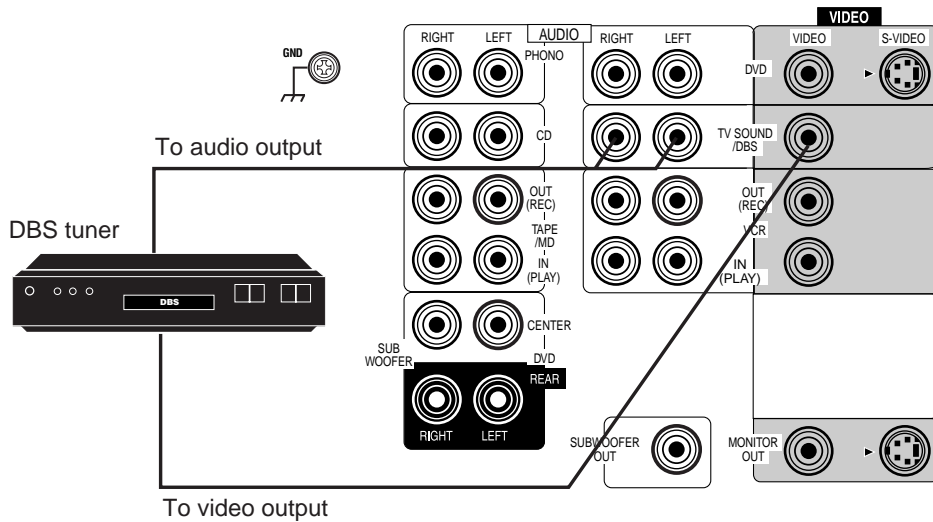

Note:

When connecting the DBS tuner to the TV SOUND/DBS jacks, change the source name, which will be shown on the display when selected as the source, to "DBS." See page 23 for details.

VCR connection

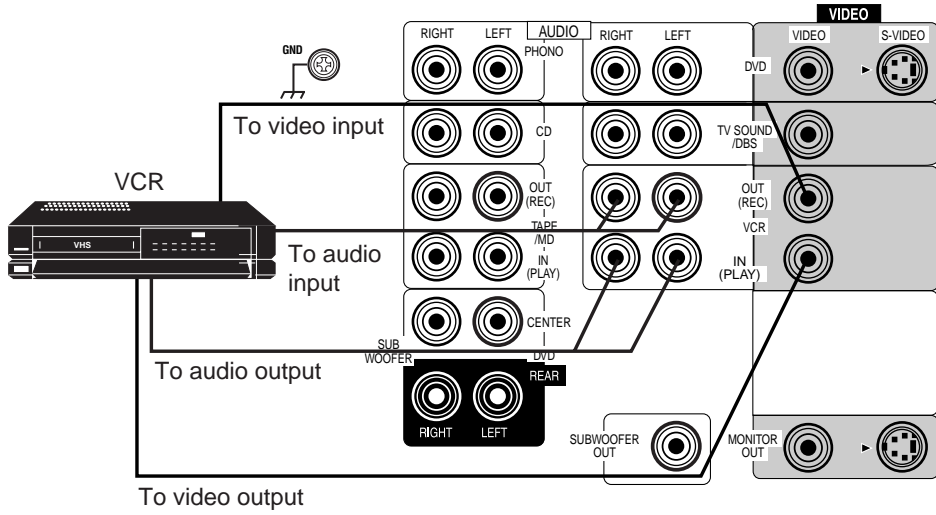

Getting Started

Connecting the Power Cord

Before plugging the receiver into an AC outlet, make sure that all connections have been made.

1. Plug the power cord into an AC outlet.
2. Press **⓪ POWER** to set it in the **■ ON** position.
The STANDBY lamp lights up. A small amount of power is always consumed.



To shut off the power completely

Press **⓪ POWER** to set it in the **■ OFF** position.

Keep the power cord away from the connecting cables and the antenna. The power cord may cause noise or screen interference. We recommend that you use a coaxial cable to connect the antenna, since it is well-shielded against interference.

The difference between the **⓪ POWER** switch and the **STANDBY/ON** button

- The **⓪ POWER** switch is the mains supply switch, allowing the receiver to connect to the mains supply. To shut off the power completely, press the **⓪ POWER** switch to set it in the **■ OFF** position.
- The **STANDBY/ON**  button is a functional on/off (standby) switch, and does not disconnect the receiver from the mains supply. A small amount of power is consumed even in standby mode for the receiver to accept signals from the remote control.

Notes:

- If the wall outlet does not match the AC plug, use the supplied AC plug adaptor.
- The preset settings such as preset channel and sound adjustment may be erased in the following cases:
 - When you press **⓪ POWER** to set it in the **■ OFF** position.
 - When you unplug the power cord.
 - When a power failure occurs.

CAUTIONS:

- Do not touch the power cord with wet hands.
- Do not pull on the power cord to unplug the cord. When unplugging the cord, always grasp the plug so as not to damage the cord.

Putting Batteries in the Remote Control

Before using the remote control, put two supplied batteries first. When using the remote control, aim the remote control directly at the remote sensor on the receiver.

1. On the back of the remote control, remove the battery cover as illustrated.
2. Insert batteries. Make sure to observe the proper polarity: (+) to (+) and (–) to (–).
3. Replace the cover.

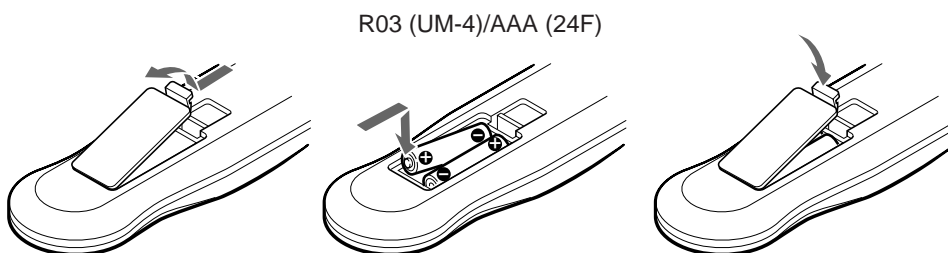

If the range or effectiveness of the remote control decreases, replace the batteries. Use two R03 (UM-4)/AAA (24F) type dry-cell batteries.

CAUTION:

- Follow these precautions to avoid leaking or cracking cells:
- Place batteries in the remote control so they match the polarity indicated: (+) to (+) and (–) to (–).
 - Use the correct type of batteries. Batteries that look similar may differ in voltage.
 - Always replace both batteries at the same time.
 - Do not expose batteries to heat or flame.

Basic Operations

The following operations are commonly used when you play any sound source.

IMPORTANT:

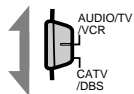

When using the Remote Control, check to see if its remote control mode selector is set to the correct position:
To operate an audio system, TV, and VCR, set it to “AUDIO/TV/VCR.”
To operate a CATV converter and DBS tuner, set it to “CATV/DBS.”

Turning the Power On and Off (Standby)

On the front panel:

To turn on the power, press STANDBY/ON . The STANDBY lamp goes off. The name of the current source (or station frequency) appears on the display.

Current source name appears

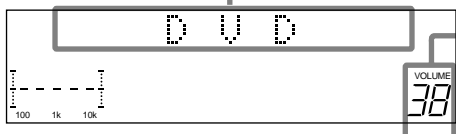

Current volume level is shown here

To turn off the power (into standby mode), press STANDBY/ON again. The STANDBY lamp lights up.

From the remote control:

To turn on the power, press AUDIO . The STANDBY lamp goes off. The name of the current source (or station frequency) appears on the display.

To turn off the power (into standby mode), press AUDIO again. The STANDBY lamp lights up.

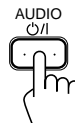
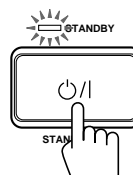
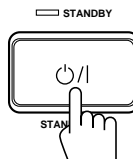

Note:

Pressing the STANDBY/ON button again turns off the power (into standby mode) and lights the STANDBY lamp. A small amount of power is consumed in standby mode. To turn the power off completely, press the POWER switch to set it in the OFF position on the front panel.

Selecting the Source to Play

On the front panel:

Turn SOURCE SELECTOR until the source name you want appears on the display.

As you turn the selector, the source changes as follows:

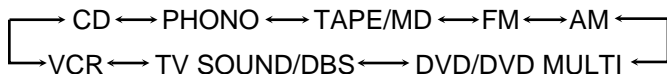

The selected source lamp also lights up.

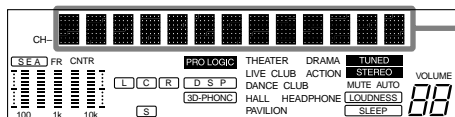

Selected source name appears

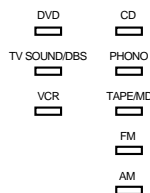
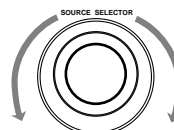

Source lamps on the front panel

For selecting DVD MULTI playback mode as the source:

Press DVD MULTI/2CH so that “DVD MULTI” appears on the display.

Each time you press the button, the DVD MULTI playback mode turns on and off, and the “DVD” and “DVD MULTI” alternately appears on the display.

- Select “DVD” when you play back a disc in stereo or the audio output setting of the DVD player is mixed to two front channels.
- Select “DVD MULTI” when you play back a disc on the DVD player with its analog discrete output mode (5.1 CH reproduction) selected. To enjoy the DVD MULTI playback mode, see page 44.

Note:

When connecting an MD recorder (to the TAPE/MD jacks), and a DBS tuner (to the TV SOUND/DBS jacks), change the source name appears on the display. See page 23 for details.

Basic Operations

From the remote control:

Press one of the source selecting buttons directly.

- | | |
|-----------|---|
| DVD MULTI | Select the DVD player for viewing the digital video disc using the analog discrete output mode (5.1CH reproduction) on the DVD player. Each time you press the button, the source alternates between "DVD" and "DVD MULTI." |
| DVD | Select the DVD player for viewing the stereo digital video disc player. ("DVD MULTI" will be selected when the last mode for the DVD playback has been the DVD MULTI playback mode.) |
| VCR | Select the video component connected to the VCR jacks. |
| TV/DBS | <ul style="list-style-type: none"> Select the TV sound, when the remote control selector is set to "AUDIO/TV/VCR." Select the DBS tuner, when the remote control selector is set to "CATV/DBS." |
| CD* | Select the CD player. |
| TAPE/MD* | Select the cassette deck (or the MD recorder). |
| PHONO* | Select the turntable. |
| FM/AM* | Select an FM or AM broadcast. Each time you press the button, the band alternates between FM and AM. |

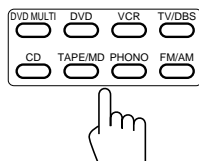

Note:

When you press one of the source selecting buttons marked above with an asterisk (*), the receiver automatically turns on.

Selecting different sources for picture and sound

You can watch picture from a video component while listening to sound from another component.

On the front panel:

- Press SOUND SELECT briefly while viewing the picture from a video component such as the VCR or DVD player, etc. "SOUND SELECT" appears on the display.
- Turn SOURCE SELECTOR to select the sounds (except the TV sound), while the indication of the above step is still on the display.

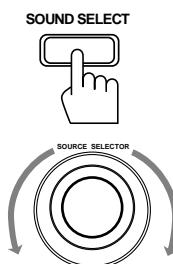

From the remote control:

Press one of the audio source selecting buttons (CD, TAPE/MD, PHONO, FM/AM), while viewing the picture from a video component such as the VCR or DVD player, etc.

Notes:

- Once you have selected a video source, pictures of the selected source are sent to the TV until you select another video source.
- When you select TV sound as the source, this function does not work.

Adjusting the Volume

On the front panel:

To increase the volume, turn MASTER VOLUME clockwise.

To decrease the volume, turn it counterclockwise.

When you turn MASTER VOLUME **rapidly**, the volume level also changes **rapidly**.
When you turn MASTER VOLUME **slowly**, the volume level also changes **slowly**.

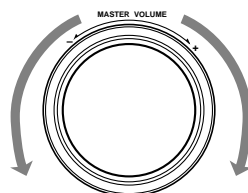

From the remote control:

To increase the volume, press VOLUME +.

To decrease the volume, press VOLUME -.

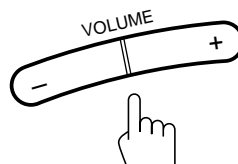

CAUTION:

Always set the volume to the minimum before starting any source. If the volume is set at its high level, the sudden blast of sound energy can permanently damage your hearing and/or ruin your speakers.

Note:

The volume level can be adjusted within the range of "0" (minimum) to "90" (maximum).

Selecting the Front Speakers

On the front panel *only*:

When you have connected two pairs of the front speakers, you can select which to use.

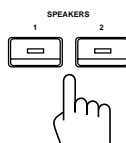

Press SPEAKERS 1 or SPEAKERS 2 to select the speaker to use.

Each time you press the button, the lamp on the respective button turns on and off. When the lamp on either button lights up, the respective speakers are activated.

IMPORTANT:

You can activate two pairs of the front speakers at the same time only when no signals are sent to the center and rear speakers. Otherwise, activating one pair of the speakers deactivates the other.

Listening only with headphones

1. Connect a pair of headphones to the PHONES jack on the front panel.
2. Press SPEAKERS 1 and/or 2 so that no lamps on the buttons are turned on.

Muting the Sound

From the remote control *only*:

Press MUTE to mute the sound through all speakers and headphones connected.

“MUTE” appears on the display and the volume turns off (the volume level indicator goes off).



To restore the sound, press MUTE again so that “OFF” appears on the display. Turning MASTER VOLUME or pressing VOLUME +/- also restores the sound at the previous volume level.

Recording a Source

You can record any source playing through the receiver to a cassette deck (or a MD recorder) connected to the TAPE/MD jacks and the VCR connected to the VCR jacks at the same time.

While recording, you can listen to the selected sound source at whatever sound level you like, without affecting the sound levels of the recording.

Note:

If you use any of the DSP modes other than the 3D-PHONIC modes and “HEADPHONE” with both front speakers activated, the speakers connected to the FRONT SPEAKERS ② terminals are deactivated.

CAUTION:

Be sure to turn down the volume before connecting or putting on headphones, as high volume can damage both the headphones and your hearing.

Note:

You cannot shut off the sound through the subwoofer using the SPEAKERS 1 and 2 buttons.

Note:

The output volume level, SEA and DSP modes cannot affect the recording.

IMPORTANT:

Before recording, turn off the DVD MULTI playback mode.

Basic Settings

Some of the following settings are required after connecting and positioning your speakers in your listening room, while others will make operations easier.

IMPORTANT:

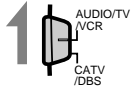

When using the Remote Control, check to see if its remote control mode selector is set to the correct position:
To operate this receiver, set it to "AUDIO/TV/VCR (except when selecting the DBS tuner as the source)."

Changing the Source Name

When you have connected an MD recorder to the TAPE/MD jacks or the DBS tuner to the TV SOUND/DBS jacks on the rear panel. Change the source name shown on the display when you select the MD recorder or DBS tuner as the source.

On the front panel only:

- When changing the source name from "TAPE" to "MD":
 - Turn SOURCE SELECTOR until "TAPE" appears.
 When changing the source name from "TV SOUND" to "DBS":
 - Turn SOURCE SELECTOR until "TV SOUND" appears.
- Press and hold LOUDNESS/SOURCE NAME until "ASSGN. MD" or "ASSGN. DBS" appears on the display.

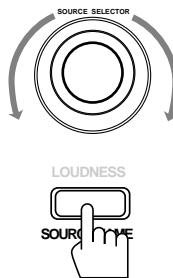

To change the source names to "TAPE" or "TV SOUND," repeat the same procedure above (in step 1, select "MD" or "DBS" then press and hold SOURCE NAME).

Adjusting the Front Speaker Output Balance

If the sounds you hear from the front right and left speakers are unequal, you can adjust the speaker output balance.

On the front panel only:

- Press BALANCE/SURROUND ADJUST repeatedly until "L/R BALANCE" appears on the display.
The display changes to show the current setting.
- Turn MULTI JOG to adjust the balance, while the indication of the previous step is still on the display.
 - Turning it clockwise decreases the left channel output.
 - Turning it counterclockwise decreases the right channel output.

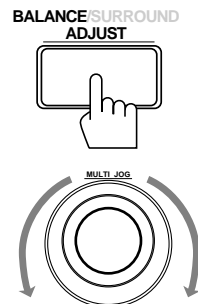

Listening at Low Volume (Loudness)

Human ears are not sensitive to bass at low volume. To compensate for this, the loudness function automatically boosts the bass level as you lower the volume.

On the front panel only:

Press LOUDNESS/SOURCE NAME briefly to select the loudness function.

Each time you press the button, the loudness function alternates between "LOUDNESS ON" and "LOUDNESS OFF."

- Select "LOUDNESS ON" to activate the loudness function.
The LOUDNESS indicator lights up on the display.
- Select "LOUDNESS OFF" to cancel it.
The indicator goes off.

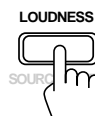

Note:

Without changing the source name, you can still use the connected components. However, there may be some inconvenience.

- "TAPE" or "TV SOUND" will appear on the display when you select the MD recorder or DBS tuner.
- You cannot use the COMPU LINK remote control system (see page 54) to operate the MD recorder.

Note:

The loudness function affects the front speaker sounds only.

Using the Sleep Timer

Using the Sleep Timer, you can fall asleep to music and know the receiver will turn off by itself rather than play all night.

From the remote control *only*:

Press **SLEEP** repeatedly.

The shut-off time on the display changes as follows, and the SLEEP indicator lights up on the display.

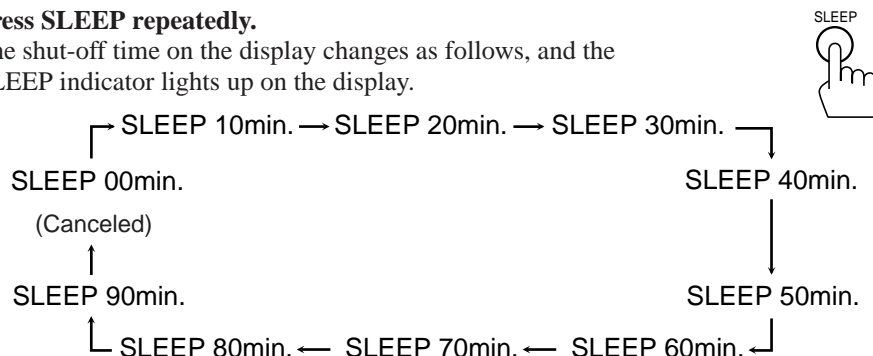

When the shut-off time comes

The receiver turns off automatically.

To check or change the time remaining until the shut-off time

Press **SLEEP** once.

The remaining time until the shut-off time appears in minutes.

- To change the shut-off time, press **SLEEP** repeatedly.

To cancel the Sleep Timer

Press **SLEEP** repeatedly until “SLEEP 00min.” appears on the display. (The SLEEP indicator goes off.)

Turning off the power also cancels the Sleep Timer.

Setting Center and Rear Speakers for DSP Modes

To obtain the best possible surround sound of the DSP modes, you have to register the information about the speakers arrangement after all connections are completed.

Center Speaker Setting

Register the center speaker size.

On the front panel *only*:

1. Press **SETTING** repeatedly until “**CENTER SPK**” (Center Speaker Size) appears on the display.
The display changes to show the current setting.
2. Turn **MULTI JOG** to select the appropriate item about your center speaker, while the indication of the previous step is still on the display.
As you turn it, the display changes to show the following:

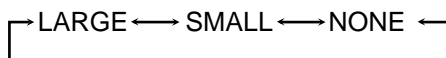

LARGE:	Select this mode when the size of the center speaker is the same as that of the front speakers.
SMALL:	Select this mode when the size of the center speaker is smaller than that of the front speakers.
NONE:	Select this mode when you do not use a center speaker.

Note:

When you change your speakers, you need to register the information about the speakers again.

Basic Settings

Rear Speaker Setting

Register whether you have connected the rear speakers or not.

On the front panel only:

1. Press **SETTING** repeatedly until “**REAR SPK**” (Rear Speaker) appears on the display.

The display changes to show the current setting.

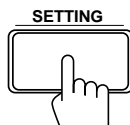

2. Turn **MULTI JOG** to register whether you have connected the rear speaker or not, while the indication of the previous step is still on the display.

As you turn it, the rear speaker setting alternates between “YES” and “NO.”

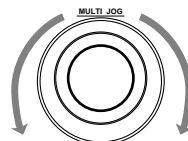

YES:	Select this mode when you use rear speakers.
NO:	Select this mode when you do not use rear speakers.

Delay Time Setting

Register the delay time of the sound from the rear speakers, comparing the sound from the front speakers.

On the front panel:

1. Press **SETTING** repeatedly until “**DELAY TIME**” appears on the display.

The display changes to show the current setting.

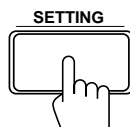

2. Turn **MULTI JOG** to select the delay time of the rear speaker output, while the indication of the previous step is still on the display.

As you turn it, the delay time changes as follows:

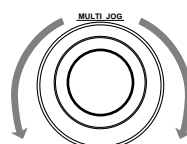

DELAY 15msec ↔ DELAY 20msec ↔ DELAY 30msec

As the distance from you to your rear speakers decreases, you will get the better surround sound by using smaller delay time.

From the remote control:

1. Press **SOUND CONTROL**.
2. Press **DELAY** repeatedly until an appropriate delay time appears on the display.

Each time you press the button, the delay time changes as follows:

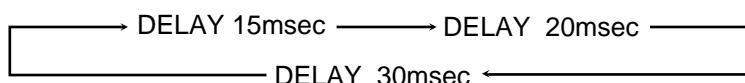

Note:

When you change your speakers, you need to register the information about the speakers again.

One Touch Operation

This receiver can memorize the optimum sound settings for each playing source.

About the One Touch Operation

JVC's One Touch Operation function is used to assign and store different sound settings for each different playing source. By using this function, you don't have to change the settings every time you change the source. The stored settings for the newly selected source are automatically recalled.

The following can be stored for each source:

- Volume level (see page 21)
- Balance (see page 23)
- Loudness (see page 23)
- SEA modes (see page 31)
- DSP modes
 - 3D-PHONIC mode settings (see page 34)
 - DAP mode settings (see page 36)
 - Surround mode settings (see page 39)
- DVD MULTI playback mode settings (see page 44)

Using the One Touch Operation

On the front panel *only*:

To store the sound settings

1. Press ONE TOUCH OPERATION.

The ONE TOUCH OPERATION lamp lights up, then the previously memorized settings are recalled.



2. Adjust the sound using the functions listed above.

The newly adjusted settings are memorized.

To recall the sound settings

With the ONE TOUCH OPERATION lamp lit, the settings for the currently selected source is recalled, when the source is selected.



To cancel the One Touch Operation function

Press ONE TOUCH OPERATION so that the lamp goes off.

(Even though the One Touch Operation function is canceled, the recalled sound effects remain active.)

Notes:

- If the source is FM or AM, you can assign a different setting for each band.
- The DSP modes and DVD MULTI playback mode cannot be used at the same time.

Receiving Radio Broadcasts

You can browse through all the stations or use the preset function to go immediately to a particular station.

IMPORTANT:

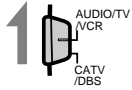

When using the Remote Control, check to see if its remote control mode selector is set to the correct position:

To operate this receiver, set it to “AUDIO/TV/VCR (except when selecting the DBS tuner as the source).”

Setting the AM Tuner Interval Spacing

Some countries space AM stations 9 kHz apart, and other countries use 10 kHz spacing. When shipped, the spacing is set to 9 kHz.

On the front panel *only*:

To select the 10 kHz interval:

Be sure the receiver is turned off, but is plugged into an AC outlet and \odot POWER is pressed to set it in the \blacksquare ON position. Hold down TUNER PRESET and press STANDBY/ON \odot /I. “10K STEP” appears on the display for about three seconds. Now the 10 kHz interval is selected.

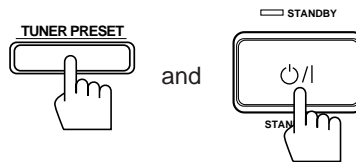

To change back to the 9 kHz interval:

Be sure the receiver is turned off, but is plugged into an AC outlet and \odot POWER is pressed to set it in the \blacksquare ON position. Hold down FM MODE and press STANDBY/ON \odot /I. “9K STEP” appears on the display for about three seconds. Now the 9 kHz interval is selected.

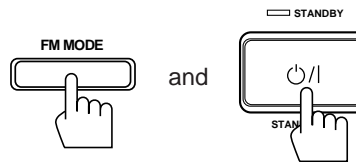

Tuning in Stations Manually

On the front panel:

1. Press FM/AM TUNING to select the band.
Each time you press the button, the band alternates between FM and AM.
2. Turn MULTI JOG until you find the frequency you want.
 - Turning it clockwise increases the frequency.
 - Turning it counterclockwise decreases the frequency.

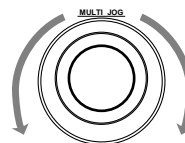
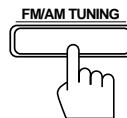

From the remote control:

1. Press FM/AM to select the band.
Each time you press the button, the band alternates between FM and AM.
2. Press TUNING DOWN or TUNING UP repeatedly until you find the frequency you want.

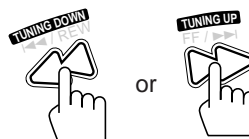

Notes:

- When you turn MULTI JOG quickly or hold TUNING DOWN or TUNING UP in step 2, the frequency keeps changing until a station is tuned in.
- When a station of sufficient signal strength is tuned in, the TUNED indicator lights up on the display. When an FM stereo program is received, the STEREO indicator also lights up.

Using Preset Tuning

Once a station is assigned to a channel number, the station can be quickly tuned. You can preset up to 40 stations at random.

To store the preset stations

On the front panel only:

1. **Tune in the station you want to preset (see page 27).**
If you want to store the FM reception mode for this station, select the FM reception mode you want. See page 29 for details.
2. **Press TUNER/SEA MEMORY.**
“CH-” appears and the channel number position starts flashing on the display for about 5 seconds.
3. **Turn MULTI JOG to select a channel number while the channel number position is flashing.**
4. **Press TUNER/SEA MEMORY again while the selected channel number is flashing on the display.**
The selected channel number stops flashing.
The station is assigned to the selected channel number.
5. **Repeat steps 1 to 4 until you store all the stations you want.**

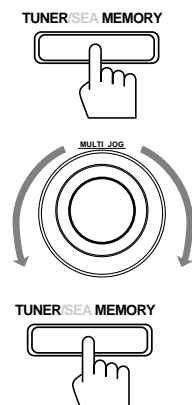

To erase a stored preset station

Storing a new station on a used number erases the previously stored one.

To tune in a preset station

On the front panel:

1. Press TUNER PRESET.
2. Turn MULTI JOG to select a preset channel.

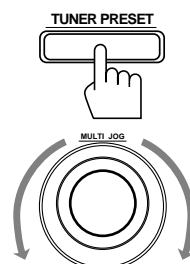

From the remote control:

1. **Press FM/AM.**
Each time you press the button, the band alternates between FM and AM.
2. **Press 10 keys to select a preset channel number.**
 - For channel number 5, press 5.
 - For channel number 15, press +10 then 5.
 - For channel number 20, press +10 then 10.
 - For channel number 30, press +10, +10, then 10.

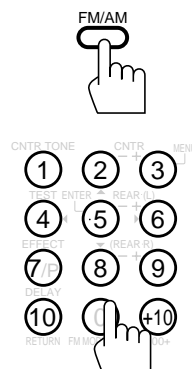

Note:

You can use the 10 keys on the remote control to select the preset number. When using the 10 keys, be sure that they are activated for tuner, not for the CD and others. (See page 62.)

Note:

When you use the 10 keys on the remote control, be sure that they are activated for tuner, not for the CD and others. (See page 62.)

Receiving Radio Broadcasts

Selecting the FM Reception Mode

On the front panel:

When an FM stereo broadcast is hard to receive or noisy, set the FM reception mode to MONO. (When shipped from the factory, this mode has been set to AUTO.)

You can change the FM reception mode while receiving an FM broadcast.

Press FM MODE to select the FM reception mode.

Each time you press the button, the FM reception mode alternates between AUTO and MONO.

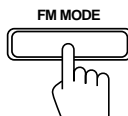

AUTO:	When a program is broadcasted in stereo, you will hear stereo sound; when in monaural, you will hear monaural sounds. This mode is also useful to suppress static noise between stations. The MUTE AUTO indicator lights up on the display.
MONO:	Reception will be improved although you will lose the stereo effect. In this mode, you will hear noise while tuning into the stations. The MUTE AUTO indicator goes off on the display.

From the remote control:

Press FM MODE/MUTE to select the FM reception mode.

Each time you press the button, the FM reception mode alternates between AUTO and MONO.



Note:

You can store the FM reception mode for each preset station.

Note:

When using the FM MODE/MUTE button, be sure that the 10 keys are activated for tuner, not for the CD and others. (See page 62.)

Assigning Names to Preset Stations

You can assign a name of up to four characters to each preset station. When a preset station is tuned in, its assigned name will appear on the display.

On the front panel *only*:

1. Tune in a preset station.

See page 28 for details.

2. Press TUNER/SEA MEMORY.

The preset channel number starts flashing for about 5 seconds.

TUNER/SEA MEMORY

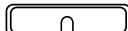

TUNER PRESET



3. Press TUNER PRESET, while the preset channel number is flashing.

The first character position starts flashing.



4. Turn MULTI JOG to select a character, while the first character position is flashing.

You can use characters listed below.

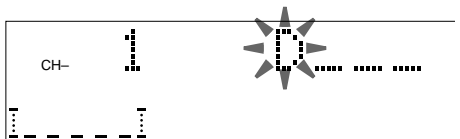
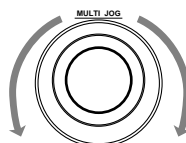

5. Press TUNER PRESET, while a character you want is flashing.

The next (or previous) character position starts flashing.

TUNER PRESET

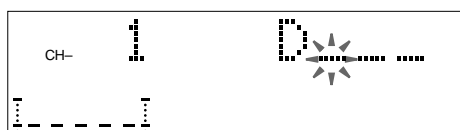
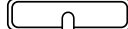

6. Repeat steps 4 and 5 to enter up to four characters.

7. Press TUNER/SEA MEMORY while the last selected character is flashing after you have assigned a name.

TUNER/SEA MEMORY

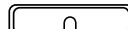

Note:

If you turn MULTI JOG while the preset channel number is flashing, you can change the preset channel number.

Note on step 3 to 7:

You cannot select any entry after the indication on the display stops flashing.

In this case, repeat the procedure from step 2 again.

To erase the input characters

Insert spaces using the same procedure described above.

Available characters

Space	A	B	C	D	E	F	G	H	I	J	K	L	M	N	O	
	P	Q	R	S	T	U	V	W	X	Y	Z	0	1	2	3	4
	5	6	7	8	9											

Using the SEA Modes

The SEA (Sound Effect Amplifier) modes give you control of the way your music sounds.

IMPORTANT:

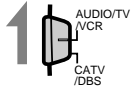

When using the Remote Control, check to see if its remote control mode selector is set to the correct position:

To operate this receiver, set it to “AUDIO/TV/VCR (except when selecting the DBS tuner as the source).”

Selecting Your Favorite SEA Mode

On the front panel:

1. Press SEA MODE.

The display changes to show the current setting.



2. Turn MULTI JOG until the mode you want appears on the display, while the indication of the previous step is still on the display.

As you turn it, the SEA mode changes as follows:

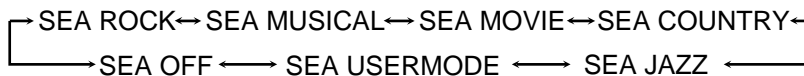
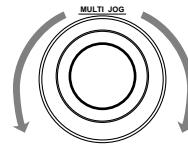

SEA ROCK:	Gives a heavy sound. Both high and low frequencies are boosted.
SEA MUSICAL:	Enhance the mid-frequency range, which the human voice is mostly made up of.
SEA MOVIE:	Adds breadth to sounds so you feel like you are in a movie theater.
SEA COUNTRY:	Enhances the high-frequency range so that instruments such the violin and banjo are emphasized.
SEA JAZZ:	Gives a feeling of a live atmosphere. Good for acoustic music.
SEA USERMODE:	Your original SEA adjustment (see page 32).
SEA OFF:	No SEA mode is applied (see below).

To cancel the SEA mode

Turn MULTI JOG until “SEA OFF” appears in step 2 above.

The SEA indicator goes off from the display.

From the remote control:

Press SEA MODE repeatedly until the SEA mode you want appears on the display.

Each time you press the button, the SEA mode changes as follows:

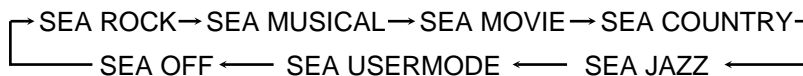
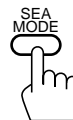

To cancel the SEA mode

Press SEA MODE repeatedly until “SEA OFF” appears.

The SEA indicator goes off from the display.

Notes:

- The SEA modes cannot be used for recording.
- When the SEA mode is turned on, the SEA indicator lights up on the display.

Note:

When the SEA mode is turned on, the SEA indicator lights up on the display.

Creating Your Own SEA Mode

You can adjust and store your own SEA adjustment into memory (SEA USERMODE).

On the front panel *only*:

If you do not want to store your adjustment, but rather want to adjust the SEA temporarily, skip step 4 below.

1. Press SEA ADJUST repeatedly until the frequency range (100Hz, 1kHz or 10kHz) you want appears on the display.

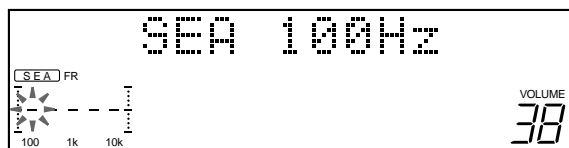

2. Turn MULTI JOG to adjust the SEA level of the selected frequency range, while the indication of the previous step is still on the display.

- Turning it clockwise increases the level.
- Turning it counterclockwise decreases the level.

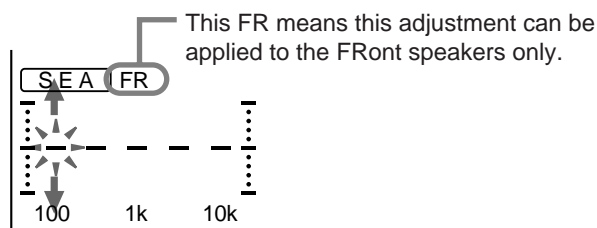
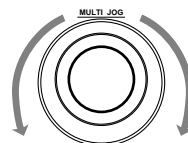

3. Repeat step 1 and 2 to adjust other frequency ranges if necessary.

4. Press TUNER/SEA MEMORY, while the indication of the previous step is still on the display.
Your adjustment is stored into SEA USERMODE.



To recall your own SEA adjustment

See page 31.

To erase a stored adjustment

Storing a new adjustment into SEA USERMODE erases the previously stored one.

Using the DSP Modes

The built-in Surround Processor provides three types of the DSP (Digital Signal Processor) mode — 3D-PHONIC mode, DAP (Digital Acoustic Processor) mode and Surround mode (Dolby Pro Logic and Theater Surround.)

On 3D-PHONIC mode

The 3D-PHONIC mode gives you such a nearly surround effect as it is reproduced through the Dolby Surround decoder, which is widely used to reproduce sounds with a feeling of movement like those experienced in movie theaters. The 3D-PHONIC mode is the result of research on sound localization technology carried out at JVC for many years and makes it possible to reproduce the surround sound **with only two front speakers**.

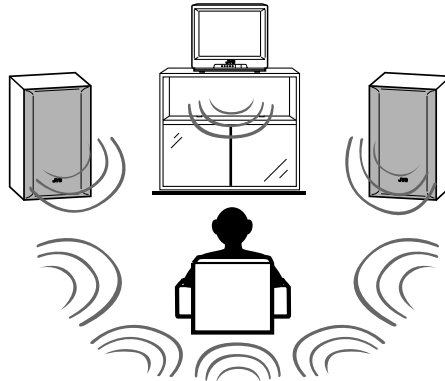

On the DAP mode

The sound heard in a concert hall or club consists of direct sound and indirect sound — early reflections and reflections from behind. Direct sounds reach the listener directly without any reflection. On the other hand, indirect sounds are delayed by the distances of the ceiling and walls. These direct sounds and indirect sounds are the most important elements of the acoustic surround effects. The DAP mode can create these important elements, and gives you a real “being there” feeling.

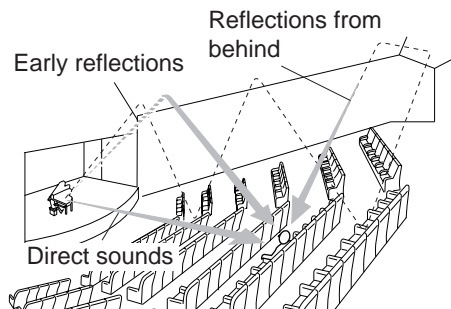

On Surround mode

With this receiver, you can use two types of the surround mode.

Dolby Pro Logic

Dolby Pro Logic has been developed to reproduce the important elements of the acoustic surround at home.

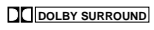
To watch the soundtracks of video software bearing the mark  * which includes the same encoded surround information as found in Dolby Stereo films, the receiver can provide you with Dolby Pro Logic.

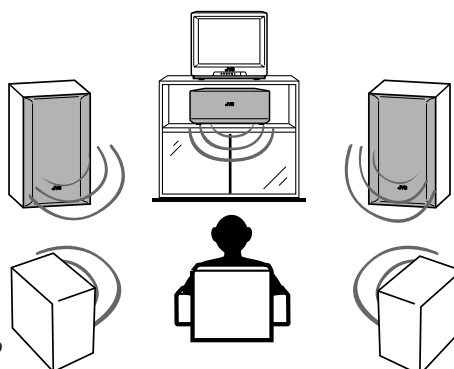

JVC's Theater Surround

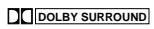
In order to reproduce a more realistic sound field in your listening room while playing soundtracks of video software bearing the mark , JVC's Theater Surround has been designed to give you clearer vocals and to create a real “being there” feeling.

Notes:

- The DSP modes has no effect on monaural sources.
- You can not use the two types of the DSP modes at the same time.
- The DSP modes cannot be used for recording.
- When you select “DVD MULTI” as the source to play, you cannot select or adjust the DSP modes.

IMPORTANT:

Before recording, turn off the DVD MULTI playback mode.

* Manufactured under license from Dolby Laboratories Licensing Corporation. “Dolby,” the double-D symbol, and “Pro Logic” are trademarks of Dolby Laboratories Licensing Corporation.

As for the DVD MULTI Playback Mode, see pages 44 to 46.



IMPORTANT:

When using the Remote Control, check to see if its remote control mode selector is set to the correct position:

To operate this receiver, set it to “AUDIO/TV/VCR (except when selecting the DBS tuner as the source).”

Using the 3D-PHONIC Modes

When using JVC’s 3D-PHONIC modes, you need only two front speakers to reproduce the soundtracks of video software bearing the mark .

The 3D-PHONIC modes give you a very realistic surround effect as if the sound is reproduced through the Dolby Pro Logic decoder.

On the front panel:

1. Press DSP MODE.

The current DSP mode appears on the display.

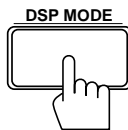

2. Turn MULTI JOG until the mode (3D ACTION, 3D DRAMA, or 3D THEATER) you want appears on the display, while the indication of the previous step is still on the display.

The 3D-PHONIC, DSP and PRO LOGIC indicators also light up on the display.

As you turn it, the DSP modes change as follows (the indicator of the DSP mode also lights up on the display):

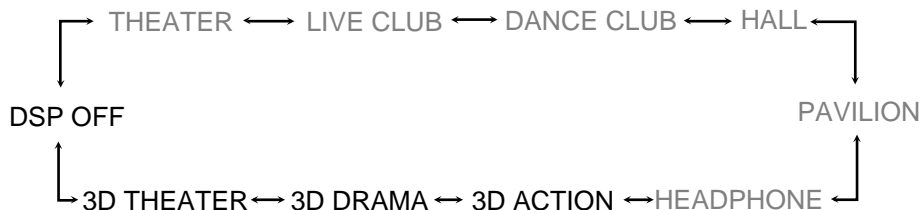
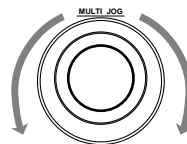

3D ACTION:	Best for action and war movies — where the action is fast and explosive.
3D DRAMA:	Best for dramas and romantic movies — where the action is slow and soft.
3D THEATER:	Reproduces the sound field of a large theater.
DSP OFF:	No DSP mode is applied.

For the other modes, see pages 36 and 39.

If you need to make any adjustment, go to the following steps.

3. Press BALANCE/SURROUND ADJUST repeatedly until “DSP EFFECT” appears on the display.

The display changes to show the current setting.



4. Turn MULTI JOG to select the effect level, while the indication of the previous step is still on the display.

As you turn it, the effect level changes as follows:

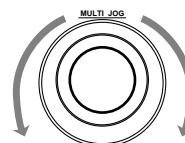
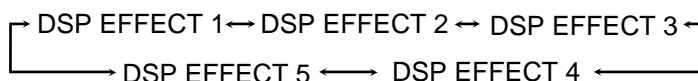

As the number increases, the selected 3D-PHONIC mode becomes stronger.

Notes:

- When you select “DVD MULTI” as the source to play, you cannot select the 3D-PHONIC modes.
- The 3D-PHONIC mode is not used with the other DSP modes such as the Dolby Pro Logic and the DAP mode. When the 3D-PHONIC mode is turned on, the other DSP mode, if used, will be turned off.

Using the DSP Modes

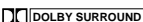
5. Select and play a sound source which was processed with Dolby Surround and is labeled with  mark.

To cancel the 3D-PHONIC mode

Turn MULTI JOG until "DSP OFF" appears in step 2.
The 3D-PHONIC, DSP and PRO LOGIC indicators go off from the display.

From the remote control:

1. Press SURROUND MODE repeatedly until the mode (3D ACTION, 3D DRAMA, or 3D THEATER) you want appears on the display.

The 3D-PHONIC, DSP and PRO LOGIC indicators also light up on the display.

Each time you press the button, the DSP modes change as follows (the indicator of the DSP mode also lights up on the display):

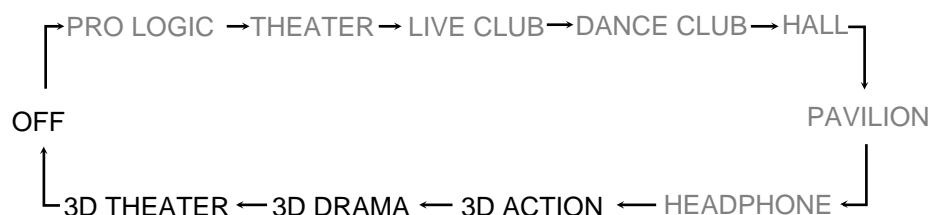

2. Press SOUND CONTROL.

10 keys are activated for sound adjustments.



3. Press EFFECT to select the effect level.

Each time you press the button, the effect level changes as follows:

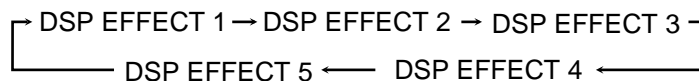

As the number increases, the selected 3D-PHONIC mode becomes stronger.

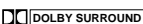
4. Select and play a sound source which was processed with Dolby Surround and is labeled with  mark.

To cancel the 3D-PHONIC mode

Press SURROUND MODE repeatedly until "OFF" appears.
The 3D-PHONIC, DSP, and PRO LOGIC indicators go off from the display.

Note:

Once you have adjusted the effect level, it is memorized for each 3D-PHONIC mode.

Notes:

- When you select "DVD MULTI" as the source to play, you cannot select the 3D-PHONIC modes.
- The 3D-PHONIC mode is not used with the other DSP modes such as the Dolby Pro Logic and the DAP mode. When the 3D-PHONIC mode is turned on, the other DSP mode, if used, will be turned off.

Using the DAP Modes

You can use five DAP modes — “Live Club, Dance Club, Hall, Pavilion, and Headphones.”

Among the DAP modes, “Headphones” is very special. It can create the same stereo sound as you listen through the speakers off air while listening to a source using headphones. So, you can feel as if you were not using the headphones and listening to music in a room.

On the front panel:

1. Press DSP MODE.

The current DSP mode appears on the display.

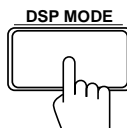

2. Turn MULTI JOG until the mode (LIVE CLUB, DANCE CLUB, HALL, PAVILION, or HEADPHONE) you want appears on the display, while the indication of the previous step is still on the display.

The DSP indicator also lights up on the display.

As you turn it, the DSP modes change as follows (the indicator of the selected DSP mode also lights up on the display):

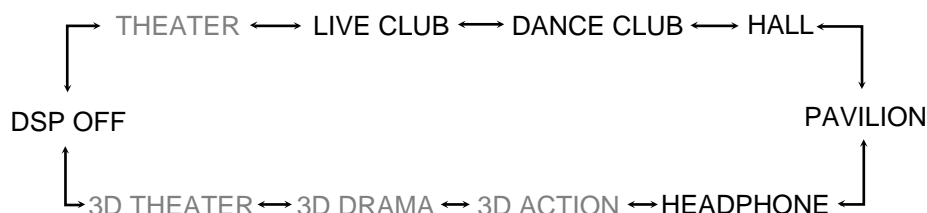
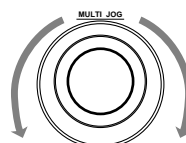

LIVE CLUB:	Gives the feeling of a live music club with a low ceiling.
DANCE CLUB:	Gives a throbbing bass beat.
HALL:	Gives clear vocal and the feeling of a concert hall.
PAVILION:	Gives the spacious feeling of a pavilion with a high ceiling.
HEADPHONE:	Gives a spacious stereo effect when listening with headphones.
DSP OFF:	No DSP mode is applied.

For the other modes, see pages 34 and 39.

If you need to make any adjustment, go to the following steps.

3. Press BALANCE/SURROUND ADJUST repeatedly until “REAR LEVEL” appears on the display.

The display changes to show the current setting.



4. Turn MULTI JOG to adjust the rear speaker output level (from -10 dB to +10 dB), while the indication of the previous step is still on the display.

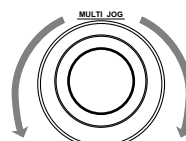

Notes:

- When you select “DVD MULTI” as the source to play, you cannot select the DAP modes.
- The DAP mode is not used with the other DSP modes such as the Dolby Pro Logic and 3D-PHONIC mode. When the DAP mode is turned on, the other DSP mode, if used, will be turned off.

Note:

When you select “HEADPHONE” (the HEADPHONE indicator lights up), you cannot go to the following steps. No adjustments can be made for “HEADPHONE.”

Notes:

- You cannot adjust the left and right rear speaker output level separately.
- You cannot adjust the rear speaker level when “REAR SPK” is set to “NO” (see page 25).

Continued to the next page.

Using the DSP Modes

5. Press **BALANCE/SURROUND ADJUST** repeatedly until “**DSP EFFECT**” appears on the display. The display changes to show the current setting.



6. Turn **MULTI JOG** to select the effect level, while the indication of the previous step is still on the display. As you turn it, the effect level changes as follows:

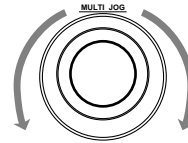
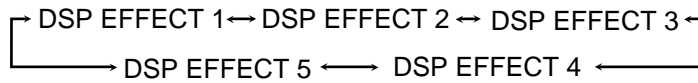

As the number increases, the selected DAP mode becomes stronger.

To cancel the DAP mode

Turn **MULTI JOG** until “**DSP OFF**” appears in step 2. The DSP indicator goes off from the display.

Note:

Once you have adjusted the DAP modes, the adjustment is memorized for each DAP mode.

From the remote control:

1. Press **SURROUND MODE** repeatedly until the mode you want appears on the display.

The DSP indicator also lights up on the display.

Each time you press the button, the DSP modes change as follows (the indicator of the selected DSP mode also lights up on the display):

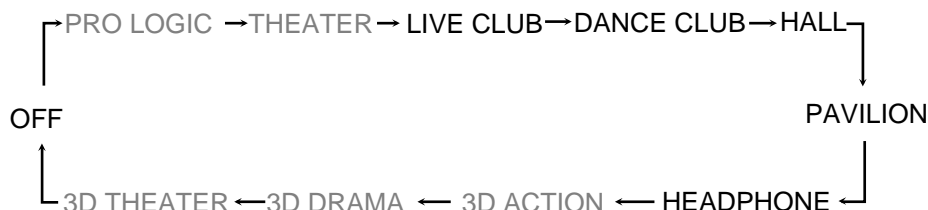

If you need to make any adjustment, go to the following steps.

2. Press **SOUND CONTROL**.

10 keys are activated for sound adjustments.



3. Press **REAR•(L) +/-** to adjust the rear speaker output level.

- Pressing REAR•(L) – decreases the output level up to –10 dB.
- Pressing REAR•(L) + increases the output level up to +10 dB.

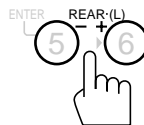

4. Press **EFFECT** to select the effect level.

Each time you press the button, the effect level changes as follows:

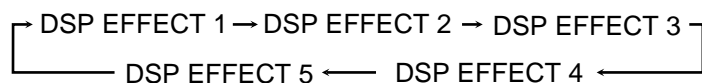

As the number increases, the selected DAP mode becomes stronger.



To cancel the DAP mode

Press **SURROUND MODE** repeatedly until “OFF” appears. The DSP indicator goes off from the display.

Notes:

- When you select “DVD MULTI” as the source to play, you cannot select the DAP modes.
- The DAP mode is not used with the other DSP modes such as the Dolby Pro Logic and 3D-PHONIC mode. When the DAP mode is turned on, the other DSP mode, if used, will be turned off.

Note:

When you select “HEADPHONE” (the HEADPHONE indicator lights up), you cannot go to the following steps. No adjustments can be made for “HEADPHONE.”

Notes:

- You cannot adjust the left and right rear speaker output level separately.
- You cannot adjust the rear speaker level when “REAR SPK” is set to “NO” (see page 25).

Note:

Once you have adjusted the DAP modes, the adjustment is memorized for each DAP mode.

Using the DSP Modes

Preparing for Surround Modes

The receiver memorizes two types of Surround modes adjustments; one for Dolby Pro Logic and the other for Theater Surround.

To do the adjustment procedure, use the remote control.

From the remote control:

1. Press **SURROUND MODE** until **“PRO LOGIC”** or **“THEATER”** appears on the display.



When **“PRO LOGIC”** is selected, the PRO LOGIC indicator also lights up on the display.

When **“THEATER”** is selected, the PRO LOGIC, DSP and THEATER indicators also light up on the display.

Each time you press the button, the DSP modes change as follows:

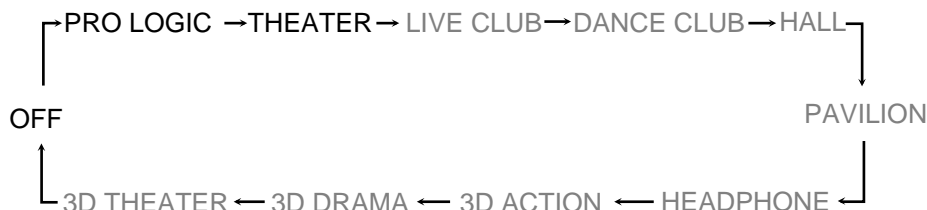

PRO LOGIC:	Select this mode to watch a video source with Dolby Surround.
THEATER:	Select this mode to watch a video source with Dolby Surround. This is JVC original surround mode and gives you the feeling of a movie theater.
OFF:	No DSP mode is applied.

For the other modes, see pages 34 and 36.

If you need to make any adjustment, go to the following steps.

2. Press **SOUND CONTROL**.

10 keys are activated for sound adjustments.



3. Press **TEST** to start checking the speaker output balance.

“TEST TONE L” starts flashing on the display, and a test tone comes out of the speakers in the following order:

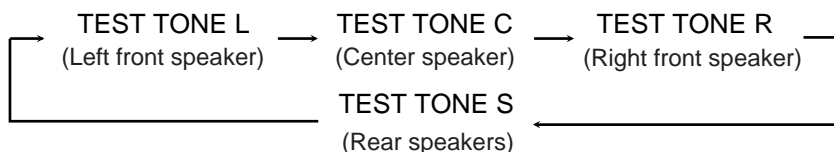

L C R	The speaker indicators also light on the display while the test tone comes out of the speakers.
S	L: Lights when the test tone comes out of the left front speaker. C: Lights when the test tone comes out of the center speaker. R: Lights when the test tone comes out of the right front speaker. S: Lights when the test tone comes out of the rear speakers.

Notes:

- When you select **“DVD MULTI”** as the source to play, you cannot select the Surround modes.
- The Surround mode is not used with the other DSP modes such as the DAP mode and 3D-PHONIC mode. When the Surround mode is turned on, the other DSP mode, if used, will be turned off.

Notes:

- No test tone comes out of the center speaker when **“CENTER SPK”** is set to **“NONE”** (see page 24).
- No test tone comes out of the rear speakers when **“REAR SPK”** is set to **“NO”** (see page 25).

4. If necessary, adjust the speaker output level as follows:

- To adjust the center speaker output level, press CNTR +/-.
- To adjust the rear speaker output level, press REAR•(L) +/-.

Pressing – decreases the output level up to –10 dB.

Pressing + increases the output level up to +10 dB.

5. Press TEST again to stop the test tone.

6. Press CNTR TONE to select the center tone level you want.

The center tone adjustment affects the mid-frequency range, which the human voice is mostly made up of. Each time you press the button, the display changes as follows:



Adjusted level are also shown on the equalizer display.

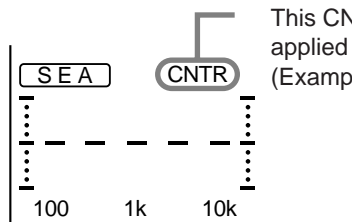

This CNTR means this adjustment can be applied to the center speaker only. (Example: When “FLAT” is selected.)

To make the dialogue clearer, select “SHARP1” (little) or “SHARP2” (much).

To make the dialogue softer, select “SOFT1” (little) or “SOFT2” (much).

When “FLAT” is selected, no adjustment is applied.

If you have selected Theater Surround, go to the following steps.

7. Press EFFECT to select the effect level.

Each time you press the button, the effect level changes as follows:

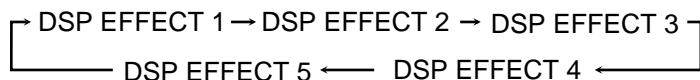

As the number increases, the surround effect becomes stronger.

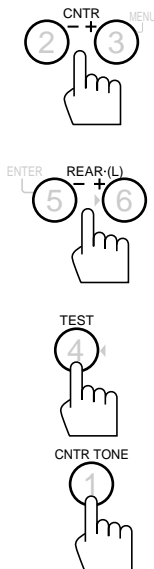

Note:

- You can adjust the speaker output levels and center tone without outputting the test tone.
- You cannot adjust the left and right rear speaker output level separately.
- You cannot adjust the center speaker level when “CENTER SPK” is set to “NONE” (see page 24).
- You cannot adjust the rear speaker level when “REAR SPK” is set to “NO” (see page 25).

Note:

The center tone cannot be adjusted when “CENTER SPK” is set to “NONE” (see page 24).

Note:

When you have selected Dolby Pro Logic, you cannot select the effect level.

Note:

Once you have adjusted the Surround modes, the adjustment is memorized for each Surround mode.

Using the DSP Modes

On the front panel:

You can also use the buttons on the front panel to adjust the Surround modes. However, no test tone is available when using the buttons on the front panel. So, make adjustments while listening to the sound of the source played back.

1. For Dolby Pro Logic:

Press **DOLBY SURROUND** so that the lamp on the button lights up and “**PRO LOGIC**” appears on the display.

The PRO LOGIC indicator also lights up.

Each time you press the button, the Dolby Pro Logic mode turns on and off.

DOLBY SURROUND

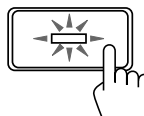

For Theater Surround:

1) Press DSP MODE.

The current DSP mode appears on the display.

2) Turn MULTI JOG until “THEATER” appears on the display, while the indication of the previous step is still on the display.

The PRO LOGIC, DSP and THEATER indicators also light up on the display.

As you turn it, the DSP modes change as follows:

DSP MODE

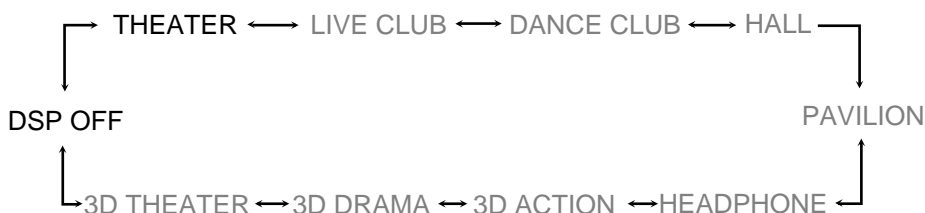
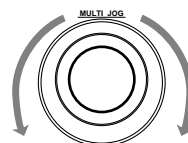
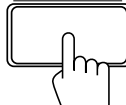

If you need to make any adjustment, go to the following steps.

2. If necessary, adjust the center speaker output level as follows.

1) Press BALANCE/SURROUND ADJUST repeatedly until “CENTER LEVEL” appears on the display.

The display changes to show the current setting.

2) Turn MULTI JOG to adjust the center speaker output level (from -10 dB to +10 dB), while the indication of the previous step is still on the display.

BALANCE/SURROUND ADJUST

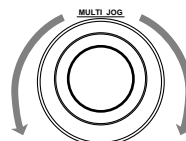

3. If necessary, adjust the rear speaker output level as follows.

1) Press BALANCE/SURROUND ADJUST repeatedly until “REAR LEVEL” appears on the display.

The display changes to show the current setting.

2) Turn MULTI JOG to adjust the rear speaker output level (from -10 dB to +10 dB), while the indication of the previous step is still on the display.

Notes:

- When you select “DVD MULTI” as the source to play, you cannot select the Surround modes.
- The Surround mode is not used with the other DSP modes such as the DAP mode and 3D-PHONIC mode. When the Surround mode is turned on, the other DSP mode, if used, will be turned off.

Note:

You cannot adjust the center speaker level when “CENTER SPK” is set to “NONE” (see page 24).

Notes:

- You cannot adjust the left and right rear speaker output level separately.
- You cannot adjust the rear speaker level when “REAR SPK” is set to “NO” (see page 25).

4. Press **BALANCE/SURROUND ADJUST** repeatedly until “**CENTER TONE**” appears on the display.
The display changes to show the current setting.



5. Turn **MULTI JOG** to select the center tone level you want, while the indication of the previous step is still on the display.

As you turn it, the display changes to show the following:

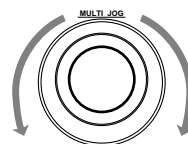

SOFT2 ↔ SOFT1 ↔ FLAT ↔ SHARP1 ↔ SHARP2

If you have selected Theater Surround, go to the following steps.

6. Press **BALANCE/SURROUND ADJUST** repeatedly until “**DSP EFFECT**” appears on the display.
The display changes to show the current setting.



7. Turn **MULTI JOG** to select the effect level, while the indication of the previous step is still on the display.
As you turn it, the effect level changes as follows:

DSP EFFECT 1 ↔ DSP EFFECT 2 ↔ DSP EFFECT 3
↔ DSP EFFECT 5 ↔ DSP EFFECT 4

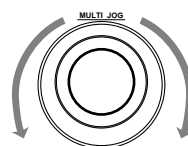

As the number increases, the surround effect becomes stronger.

Note:

The center tone cannot be adjusted when “**CENTER SPK**” is set to “**NONE**” (see page 24).

Note:

When you have selected Dolby Pro Logic, you cannot select the effect level.

Note:

Once you have adjusted the Surround modes, the adjustment is memorized for each Surround mode.

Using the DSP Modes

Using Surround Modes

Once you have finished adjustments for Dolby Pro Logic and Theater Surround, you can use the same adjustments every time you want to use these modes.

On the front panel:

1. For Dolby Pro Logic:

Press **DOLBY SURROUND** so that the lamp on the button lights up and “**PRO LOGIC**” appears on the display.

The PRO LOGIC indicator also lights up.

Each time you press the button, the Dolby Pro Logic mode turns on and off.

DOLBY SURROUND

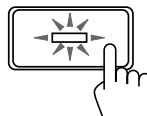

For Theater Surround:

1) Press DSP MODE.

The current DSP mode appears on the display.

2) Turn MULTI JOG until “THEATER” appears on the display, while the indication of the previous step is still on the display.

The PRO LOGIC, DSP and THEATER indicators also light up on the display.

DSP MODE

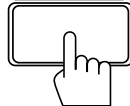

MULTI JOG



2. Select and play a sound source which was processed with Dolby Surround and is labeled with mark.

To cancel the Surround mode

For Dolby Pro Logic: Press DOLBY SURROUND again so that “SURROUND OFF” appears on the display.

For Theater Surround: Press DSP MODE, then turn MULTI JOG until “DSP OFF” appears on the display.

From the remote control:

1. Press SURROUND MODE repeatedly until “PRO LOGIC” or “THEATER” appears on the display.

When “PRO LOGIC” is selected, the PRO LOGIC indicator also lights up on the display.

When “THEATER” is selected, the PRO LOGIC, DSP and THEATER indicators also light up on the display.

SOUND CONTROL



2. Select and play a sound source which was processed with Dolby Surround and is labeled with mark.

To cancel the surround mode

Press SURROUND MODE repeatedly until “OFF” appears.

Notes:

- When you select “DVD MULTI” as the source to play, you cannot select the Surround modes.
- The Surround mode is not used with the other DSP modes such as the DAP mode and 3D-PHONIC mode. When the Surround mode is turned on, the other DSP mode, if used, will be turned off.

Using the DVD MULTI Playback Mode

This receiver provides the DVD MULTI playback mode for reproducing the analog discrete output mode of the DVD player.

Before playing back a DVD, refer also to the manual supplied with the DVD player.

Speaker Arrangements for DVD MULTI Playback

The following illustrations show how to obtain the optimum sound environment for the DVD MULTI playback mode. Try to find the speaker direction and location to create the optimum sound field.

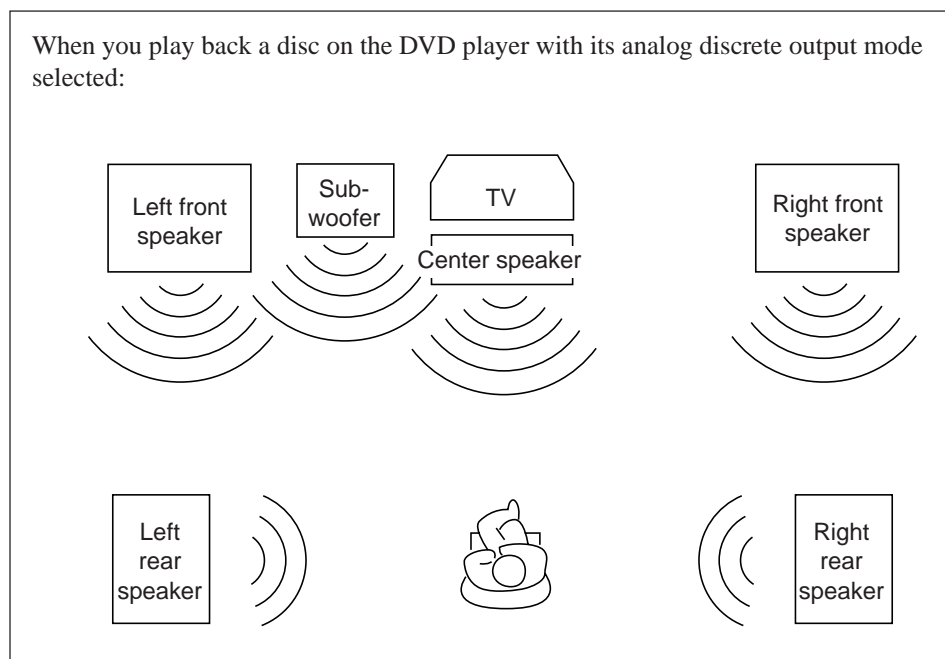

Note:

You can place the subwoofer anywhere around you.

Activating the DVD MULTI Playback

You can adjust the DVD MULTI playback mode while playing back a DVD using the analog discrete output mode on the DVD player.

Once you made adjustments, the receiver memorizes the adjustments until you change them. You also need to set the DVD player to the analog discrete output mode.

On the front panel:

1. Press DVD MULTI/2CH so that "DVD MULTI" appears on the display.



2. Select the analog discrete output mode on the DVD player, and start playing a DVD.
 - Refer to the manual supplied with the DVD player.

If you need to make any adjustment, go to the following steps.

3. Press BALANCE/SURROUND ADJUST repeatedly until "CENTER LEVEL" appears on the display. The display changes to show the current setting.



Note:

When you select "DVD MULTI" as the source to play, the DSP modes are canceled temporarily.

Note:

You cannot adjust the center speaker level when "CENTER SPK" is set to "NONE" (see page 24).

Continued to the next page.

Using the DVD MULTI Playback Mode

4. Turn **MULTI JOG** to adjust the center speaker output level (from -10 dB to $+10$ dB), while the indication of the previous step is still on the display.

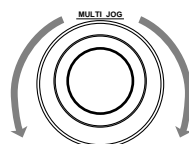

5. Press **BALANCE/SURROUND ADJUST** repeatedly until “**REAR L LEVEL**” appears on the display. The display changes to show the current setting.



6. Turn **MULTI JOG** to adjust the left rear speaker output level (from -10 dB to $+10$ dB), while the indication of the previous step is still on the display.

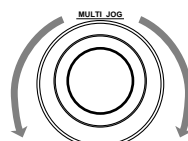

7. Press **BALANCE/SURROUND ADJUST** repeatedly until “**REAR R LEVEL**” appears on the display. The display changes to show the current setting.



8. Turn **MULTI JOG** to adjust the right rear speaker output level (from -10 dB to $+10$ dB), while the indication of the previous step is still on the display.

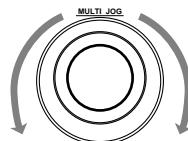

9. Press **BALANCE/SURROUND ADJUST** repeatedly until “**CENTER TONE**” appears on the display. The display changes to show the current setting.



10. Turn **MULTI JOG** to select the center tone level, while the indication of the previous step is still on the display.

The center tone level affects the mid-frequency range, which the human voice is mostly made up of. As you turn it, the display changes to show the following:

SOFT2 ↔ SOFT1 ↔ FLAT ↔ SHARP1 ↔ SHARP2

To make the dialogue clearer, select “**SHARP1**” (little) or “**SHARP2**” (much).

To make the dialogue softer, select “**SOFT1**” (little) or “**SOFT2**” (much).

When “**FLAT**” is selected, no adjustment is applied.

Note:

You cannot adjust the left rear speaker level when “**REAR SPK**” is set to “**NO**” (see page 25).

Note:

You cannot adjust the right rear speaker level when “**REAR SPK**” is set to “**NO**” (see page 25).

Note:

The center tone cannot be adjusted when “**CENTER SPK**” is set to “**NONE**” (see page 24).

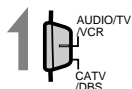
IMPORTANT:

When using the Remote Control, check to see if its remote control mode selector is set to the correct position:

To operate this receiver, set it to “AUDIO/TV/VCR (except when selecting the DBS tuner as the source).”

From the remote control:

1. Press DVD MULTI so that “DVD MULTI” appears on the display.

Each time you press the button, the source alternates between “DVD” and “DVD MULTI.”



2. Select the analog discrete output mode on the DVD player, and start playing a DVD.

- Refer to the manual supplied with the DVD player.

If you need to make any adjustment, go to the following steps.

3. Press SOUND CONTROL.

10 keys are activated for adjusting the sound.



4. Press CNTR +/- to adjust the center speaker output level.

- Pressing CNTR – decreases the output level up to –10 dB.
- Pressing CNTR + increases the output level up to +10 dB.

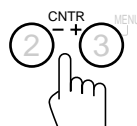

5. Press REAR•(L) +/- to adjust the left rear speaker output level.

- Pressing REAR•(L) – decreases the output level up to –10 dB.
- Pressing REAR•(L) + increases the output level up to +10 dB.



6. Press (REAR•R) +/- to adjust the right rear speaker output level.

- Pressing (REAR•R) – decreases the output level up to –10 dB.
- Pressing (REAR•R) + increases the output level up to +10 dB.



7. Press CENTER TONE to select the center tone level.

Each time you press the button, the display changes to show the following:



To make the dialogue clearer, select “SHARP1” (little) or “SHARP2” (much).

To make the dialogue softer, select “SOFT1” (little) or “SOFT2” (much).

When “FLAT” is selected, no adjustment is applied.

Note:

You cannot adjust the center speaker level when “CENTER SPK” is set to “NONE” (see page 24).

Note:

You cannot adjust the left rear speaker level when “REAR SPK” is set to “NO” (see page 25).

Note:

You cannot adjust the right rear speaker level when “REAR SPK” is set to “NO” (see page 25).

Note:

The center tone cannot be adjusted when “CENTER SPK” is set to “NONE” (see page 24).

Using the On-Screen Menus

You can use the Menus on the TV screen to control the receiver.

To use this function, you need to connect the TV to the MONITOR OUT jack on the rear panel (see page 15), and set the TV's input mode to the proper position to which the receiver is connected.

Selecting the Source to Play (Also see page 20)

1. Press any button of ON SCREEN CONTROL Δ / ∇ / \triangleleft / \triangleright once.

The MAIN MENU appears on the TV.

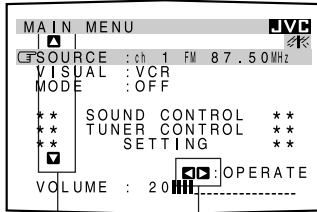

MAIN MENU

Shows the buttons you can use on the current menu.

In this case, use Δ / ∇ to move \square up and down, and \triangleleft / \triangleright to select, adjust or set the item.

2. Press ON SCREEN CONTROL Δ / ∇ to move \square to "SOURCE."

3. Press ON SCREEN CONTROL \triangleleft / \triangleright to select the source.

4. When you finish, press EXIT.

The menu disappears from the TV.

Selecting the Different Sources for Picture and Sound

You can view the pictures played back on a video component while listening to any source.

1. Press any button of ON SCREEN CONTROL Δ / ∇ / \triangleleft / \triangleright once.

The MAIN MENU appears on the TV.

2. Press ON SCREEN CONTROL Δ / ∇ to move \square to "VISUAL."

3. Press ON SCREEN CONTROL \triangleleft / \triangleright to select a different video source.

- When you select "OSD," see page 56.

4. When you finish, press EXIT.

The menu disappears from the TV.

Using the DSP Modes (Also see pages 34, 36, and 39)

1. Press any button of ON SCREEN CONTROL Δ / ∇ / \triangleleft / \triangleright once.

The MAIN MENU appears on the TV.

2. Press ON SCREEN CONTROL Δ / ∇ to move \square to "MODE."

3. Press ON SCREEN CONTROL \triangleleft / \triangleright to select the DSP mode you want to use.

4. When you finish, press EXIT.

The menu disappears from the TV.

Notes:

- If your TV is not of the PAL color system, the TV screen will be distorted.
- The on-screen display will disappear if no operation is done for about 1 minute.

MAIN MENU

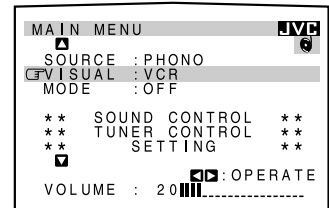

MAIN MENU

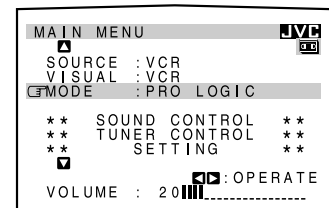

■ Adjusting the Front Speaker Output Balance (Also see page 23)

1. Press any button of ON SCREEN CONTROL $\Delta / \nabla / \triangleleft / \triangleright$ once.
The MAIN MENU appears on the TV.
2. Press ON SCREEN CONTROL Δ / ∇ to move \square to "SOUND CONTROL," then press $\triangleleft / \triangleright$.
The SOUND CONTROL menu appears on the TV.
3. Press ON SCREEN CONTROL Δ / ∇ to move \square to "BAL." (Balance).
4. Press ON SCREEN CONTROL $\triangleleft / \triangleright$ to adjust the balance.
5. When you finish, press EXIT repeatedly until the menu disappears from the TV.

■ Listening at Low Volume (Loudness) (Also see page 23)

1. Press any button of ON SCREEN CONTROL $\Delta / \nabla / \triangleleft / \triangleright$ once.
The MAIN MENU appears on the TV.
2. Press ON SCREEN CONTROL Δ / ∇ to move \square to "SOUND CONTROL," then press $\triangleleft / \triangleright$.
The SOUND CONTROL menu appears on the TV.
3. Press ON SCREEN CONTROL Δ / ∇ to move \square to "LOUDNESS."
4. Press ON SCREEN CONTROL $\triangleleft / \triangleright$ to turn the loudness "ON" or "OFF."
5. When you finish, press EXIT repeatedly until the menu disappears from the TV.

■ Adjusting the DSP Modes (Also see pages 34, 36, and 39)

1. Press any button of ON SCREEN CONTROL $\Delta / \nabla / \triangleleft / \triangleright$ once.
The MAIN MENU appears on the TV.
2. Press ON SCREEN CONTROL Δ / ∇ to move \square to "MODE."
3. Press ON SCREEN CONTROL $\triangleleft / \triangleright$ to select the DSP mode you want to adjust.
4. Press ON SCREEN CONTROL Δ / ∇ to move \square to "SOUND CONTROL," then press $\triangleleft / \triangleright$.
The SOUND CONTROL menu appears.
5. Press ON SCREEN CONTROL Δ / ∇ to move \square to "SURROUND LEVEL," then press $\triangleleft / \triangleright$.
The SURROUND LEVEL menu appears.

MAIN MENU

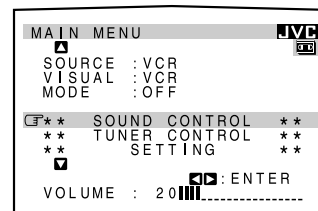

SOUND CONTROL menu

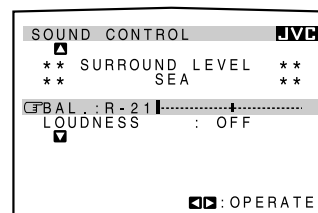

SOUND CONTROL menu

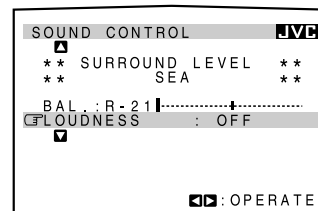

SOUND CONTROL menu

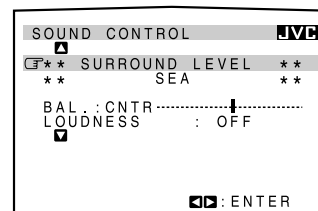

Note:

If you select "HEADPHONE" in step 3, the SURROUND LEVEL menu will not appear.

Continued to the next page.

Using the On-Screen Menus

6. Press ON SCREEN CONTROL Δ / ∇ to move \leftarrow to the item you want to set or adjust, then press ON SCREEN CONTROL $\triangleleft / \triangleright$.

On these adjustment menus, you can do the following:

For 3D-PHONIC modes:

“DSP EFFECT”*: Select the effect level.

For DAP modes (LIVE CLUB, DANCE CLUB, HALL, PAVILION):

“REAR LEVEL”*: Adjust the rear speaker output level. *

“DSP EFFECT”*: Select the effect level.

For Dolby Pro Logic surround mode:

“TEST TONE”*: Output a test tone.

“CENTER LEVEL”*: Adjust the center speaker output level. **

“REAR LEVEL”*: Adjust the rear speaker output level. *

“CENTER TONE”*: Select the center tone level. **

For Theater surround mode:

“TEST TONE”*: Output a test tone.

“CENTER LEVEL”*: Adjust the center speaker output level. **

“REAR LEVEL”*: Adjust the rear speaker output level. *

“CENTER TONE”*: Select the center tone level. **

“DSP EFFECT”*: Select the effect level. *

For DVD MULTI playback mode:

“CENTER LEVEL”*: Adjust the center speaker output level.

“REAR L LEVEL”*: Adjust the left rear speaker output level.

“REAR R LEVEL”*: Adjust the right rear speaker output level.

“CENTER TONE”*: Select the center tone level.

7. When you finish, press EXIT repeatedly until the menu disappears from the TV.

Selecting Your Favorite SEA Mode (Also see page 31)

1. Press any button of ON SCREEN CONTROL $\Delta / \nabla / \triangleleft / \triangleright$ once.
The MAIN MENU appears on the TV.
2. Press ON SCREEN CONTROL Δ / ∇ to move \leftarrow to “SOUND CONTROL,” then press $\triangleleft / \triangleright$.
The SOUND CONTROL menu appears.
3. Press ON SCREEN CONTROL Δ / ∇ to move \leftarrow to “SEA,” then press $\triangleleft / \triangleright$.
The SEA menu appears.
4. Press ON SCREEN CONTROL Δ / ∇ to move \leftarrow to “SEA MODE.”
5. Press ON SCREEN CONTROL $\triangleleft / \triangleright$ to select the SEA mode you want.
6. When you finish, press EXIT repeatedly until the menu disappears from the TV.

Example:
SURROUND LEVEL menu
for Theater surround

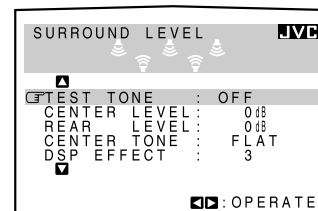

Notes:

* Not displayed when “REAR SPK” is set to “NO” (see page 25).

** Not displayed when “CENTER SPK” is set to “NONE” (see page 24).

MAIN MENU

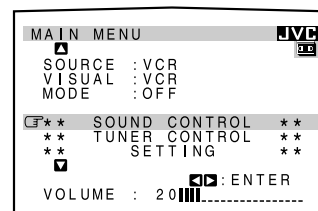

SOUND CONTROL menu

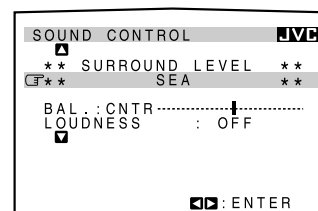

SEA menu

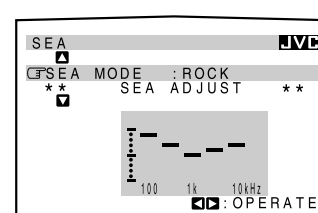

Creating Your Own SEA Mode (Also see page 32)

1. Press any button of ON SCREEN CONTROL $\Delta / \nabla / \triangleleft / \triangleright$ once.
The MAIN MENU appears on the TV.
2. Press ON SCREEN CONTROL Δ / ∇ to move \square to "SOUND CONTROL," then press $\triangleleft / \triangleright$.
The SOUND CONTROL menu appears.
3. Press ON SCREEN CONTROL Δ / ∇ to move \square to "SEA," then press $\triangleleft / \triangleright$.
The SEA menu appears.
4. Press ON SCREEN CONTROL Δ / ∇ to move \square to "SEA ADJUST," then press $\triangleleft / \triangleright$.
The SEA ADJUST menu appears.
5. Press ON SCREEN CONTROL $\Delta / \nabla / \triangleleft / \triangleright$ to adjust the SEA mode as you want.
 $\triangleleft / \triangleright$: Select the frequency ranges.
 Δ / ∇ : Adjust the frequency levels.
6. Press SET to store the setting into the SEA USERMODE.
 - If you press EXIT, without pressing SET in this step, you can return to the SEA menu. (The adjustment you have made is active but not stored.)
7. When you finish, press EXIT repeatedly until the menu disappears from the TV.

Setting the Center Speaker Size (Also see page 24)

1. Press any button of ON SCREEN CONTROL $\Delta / \nabla / \triangleleft / \triangleright$ once.
The MAIN MENU appears on the TV.
2. Press ON SCREEN CONTROL Δ / ∇ to move \square to "SETTING," then press $\triangleleft / \triangleright$.
The SETTING menu appears.
3. Press ON SCREEN CONTROL Δ / ∇ to move \square to "CENTER SPK" (Center Speaker Size).
4. Press ON SCREEN CONTROL $\triangleleft / \triangleright$ repeatedly until the appropriate center speaker size is selected.
5. When you finish, press EXIT repeatedly until the menu disappears from the TV.

MAIN MENU

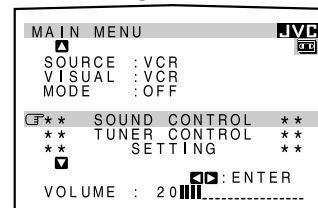

SOUND CONTROL menu

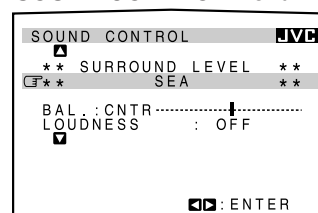

SEA menu

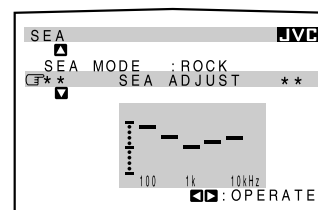

SEA ADJUST menu

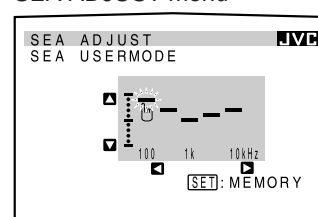

SETTING menu

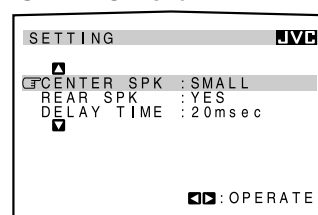

Using the On-Screen Menus

Setting the Rear Speaker (Also see page 25)

1. Press any button of ON SCREEN CONTROL $\Delta / \nabla / \triangleleft / \triangleright$ once.
The MAIN MENU appears on the TV.
2. Press ON SCREEN CONTROL Δ / ∇ to move \square to "SETTING," then press $\triangleleft / \triangleright$.
The SETTING menu appears.
3. Press ON SCREEN CONTROL Δ / ∇ to move \square to "REAR SPK" (Rear Speaker).
4. Press ON SCREEN CONTROL $\triangleleft / \triangleright$ to set your rear speakers.
5. When you finish, press EXIT repeatedly until the menu disappears from the TV.

Setting the Delay Time (Also see page 25)

1. Press any button of ON SCREEN CONTROL $\Delta / \nabla / \triangleleft / \triangleright$ once.
The MAIN MENU appears on the TV.
2. Press ON SCREEN CONTROL Δ / ∇ to move \square to "SETTING," then press $\triangleleft / \triangleright$.
The SETTING menu appears.
3. Press ON SCREEN CONTROL Δ / ∇ to move \square to "DELAY TIME."
4. Press ON SCREEN CONTROL $\triangleleft / \triangleright$ to set the delay time of the rear speaker sound.
5. When you finish, press EXIT repeatedly until the menu disappears from the TV.

Operating the Tuner

1. Press any button of ON SCREEN CONTROL $\Delta / \nabla / \triangleleft / \triangleright$ once.
The MAIN MENU appears on the TV.
2. Press ON SCREEN CONTROL Δ / ∇ to move \square to "TUNER CONTROL," then press $\triangleleft / \triangleright$.
The TUNER CONTROL menu appears.
3. Press ON SCREEN CONTROL Δ / ∇ to move \square to the item you want to set or adjust, then press ON SCREEN CONTROL $\triangleleft / \triangleright$.
On the TUNER CONTROL menu, you can do the following:
 - "PRESET CH": Select a preset channel station. (See page 28)
 - "BAND": Select the band. (See page 27)
 - "FREQUENCY": Tune in a station manually. (See page 27)
 - "FM MODE": Select the FM reception mode. (See page 29) *
 - "PRESET MEMORY": See "Storing the Preset Stations" on the next page.
4. When you finish, press EXIT repeatedly until the menu disappears from the TV.

MAIN MENU

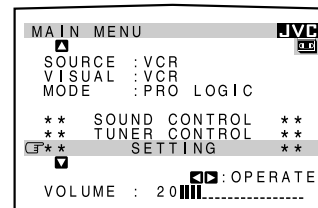

SETTING menu

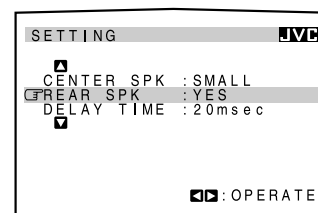

SETTING menu

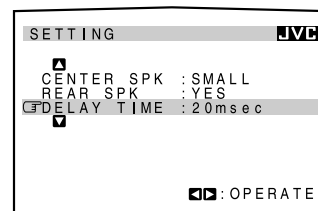

MAIN MENU

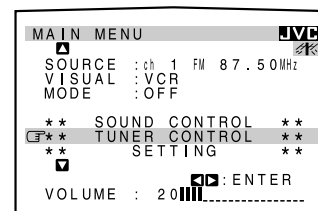

TUNER CONTROL menu

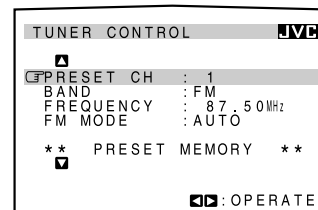

Note:

* Not displayed when an AM station is selected.

Storing the Preset Stations (Also see page 28)

1. Press any button of ON SCREEN CONTROL Δ / ∇ / \triangleleft / \triangleright once.
The MAIN MENU appears on the TV.
2. Press ON SCREEN CONTROL Δ / ∇ to move \square to "TUNER CONTROL," then press \triangleleft / \triangleright .
The TUNER CONTROL menu appears.
3. Tune into a station on the TUNER CONTROL menu, referring to "Operating the Tuner".
4. Press ON SCREEN CONTROL Δ / ∇ to move \square to "PRESET MEMORY," then press \triangleleft / \triangleright .
The PRESET MEMORY menu appears.
5. Press ON SCREEN CONTROL Δ / ∇ to move \square to "PRESET CH."
6. Press ON SCREEN CONTROL \triangleleft / \triangleright to select a preset station number you want.
7. Press SET to store the setting.
8. When you finish, press EXIT repeatedly until the menu disappears from the TV.

Assigning Names to the Preset Stations (Also see page 30)

1. Press any button of ON SCREEN CONTROL Δ / ∇ / \triangleleft / \triangleright once.
The MAIN MENU appears on the TV.
2. Press ON SCREEN CONTROL Δ / ∇ to move \square to "TUNER CONTROL," then press \triangleleft / \triangleright .
The TUNER CONTROL menu appears.
3. Press ON SCREEN CONTROL Δ / ∇ to move \square to "PRESET CH."
4. Press ON SCREEN CONTROL \triangleleft / \triangleright to select a preset station.
5. Press ON SCREEN CONTROL Δ / ∇ to move \square to "PRESET MEMORY," then press \triangleleft / \triangleright .
The PRESET MEMORY menu appears.
6. Press ON SCREEN CONTROL Δ / ∇ to move \square to "PRESET NAME," then press SET.
The character entry screen appears.

Continued to the next page.

MAIN MENU

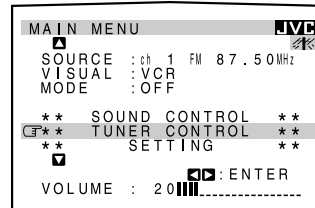

TUNER CONTROL menu

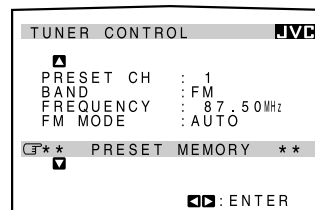

PRESET MEMORY menu

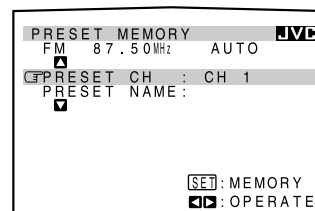

MAIN MENU

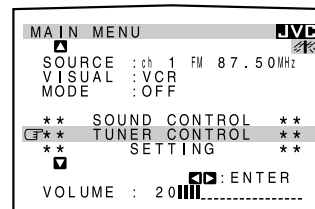

TUNER CONTROL menu

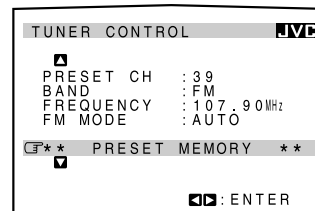

PRESET MEMORY menu

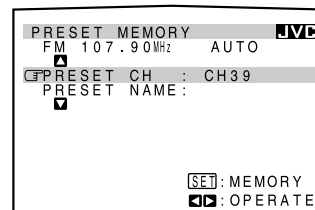

Using the On-Screen Menus

7. Press ON SCREEN CONTROL $\Delta / \nabla / \leftarrow / \rightarrow$ to move C in front of a character you want.

You can also select the following:

SPACE: To enter space

CANCEL: To erase the character

\leftarrow \rightarrow : To go back to the previous character position or go to the next character position

8. Press SET to enter the selected character.

9. Repeat steps 7 and 8 to enter up to four characters.

10. Press ON SCREEN CONTROL $\Delta / \nabla / \leftarrow / \rightarrow$ to move C to "PRESET NAME," then press SET to store the setting.

The TUNER CONTROL menu appears again.

11. When you finish, press EXIT repeatedly until the menu disappears from the TV.

PRESET MEMORY menu:
Character entry screen

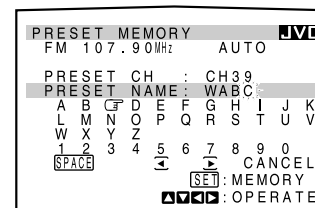
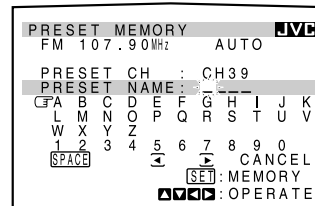

COMPU LINK Remote Control System

The COMPU LINK remote control system allows you to operate JVC audio components through the remote sensor on the receiver.

To use this remote control system, you need to connect JVC audio components through the COMPU LINK-3 (SYNCHRO) jacks (see below) in addition to the connections using cables with RCA pin plugs (see page 14).

- Make sure that the AC power cords of these components are unplugged before connection. Plug the AC power cords only after all connections are complete.

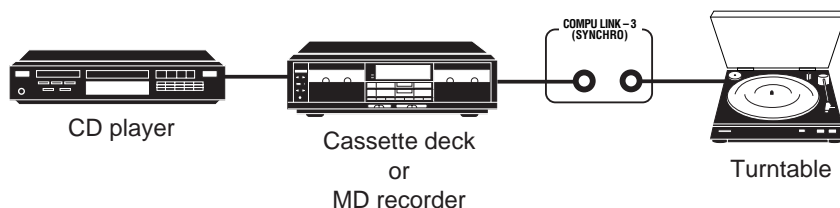

This remote control system allows you to use four functions listed below.

Remote Control through the Remote Sensor on the Receiver

You can control the connected audio components through the remote sensor on the receiver using this remote control. Aim the remote control directly at the remote sensor on the receiver. For details, see pages 62 and 63.

Automatic Source Selection

When you press the play (▶) button on a connected component or on its own remote control, the receiver automatically turns on and changes the source to the component. On the other hand, if you select a new source on the receiver or the remote control, the selected component begins playing immediately. In both cases, the previously selected source continues playing without sound for a few seconds.

Automatic Power On/Off (Standby): only possible with the COMPU LINK-3 connection

Both the CD player and cassette deck (or MD recorder) turn on and off (standby) along with the receiver.

When you turn on the receiver, the CD player or cassette deck (or MD recorder) will turn on automatically, depending on which component has been previously selected. When you turn off the receiver, both the CD player and cassette deck (or MD recorder) will turn off (standby).

Synchronized Recording

Synchronized recording means the cassette deck (or MD recorder) starts recording as soon as a CD or a record begins playing.

To use synchronized recording, follow these steps:

1. Put a tape in the cassette deck (or an MD in the MD recorder), and a disc in the CD player (or a record on the turntable).
2. Press the record (●) button and the pause (||) button on the cassette deck (or MD recorder) at the same time.

This puts the cassette deck (or MD recorder) into recording pause.

If you do not press the record (●) button and pause (||) button at the same time, the synchronized recording feature will not operate.

3. Press the play (▶) button on the CD player or on the turntable.

The source changes on the receiver, and as soon as play starts, the cassette deck (or MD recorder) starts recording. When the play ends, the cassette deck (or MD recorder) enters recording pause, and stops about 4 seconds later.

Notes:

- If your audio component has two COMPU LINK-3 (SYNCHRO) jacks, you can use either one. If it has only one COMPU LINK-3 (SYNCHRO) jack, connect it so that it is the last item in the series of components. (For example, the turntable or CD player in the diagram to the left.)
- To operate the cassette deck or MD recorder using the COMPU LINK remote control system, set the source name correctly. (See page 23.)
- Refer also to the manuals supplied with your audio components.

Notes:

- During synchronized recording, the selected source cannot be changed.
- If your CD player is playing in program mode, a 4-second blank is recorded between tracks so that the music scan feature of your cassette deck can be used on the recorded tape.
- If the power of any component is shut off during synchronized recording, the COMPU LINK remote control system may not operate properly. In this case, you must start again from the beginning.

TEXT COMPU LINK Remote Control System

The TEXT COMPU LINK remote control system has been newly developed to deal with the disc information recorded in the CD Text* and MDs. Using these information in the discs, you can operate the CD player or MD recorder equipped with the TEXT COMPU LINK remote control system through the receiver.

CONNECTIONS:

To use this remote control system, you need to connect the CD player and/or MD recorder you want to operate, following the procedures below.

1. If you have already plugged your CD player, MD recorder, and this receiver into the AC outlets, unplug their AC power cords first.
2. Connect your CD player, MD recorder, and this receiver as follows, through the COMPU LINK-3 (SYNCHRO) jacks and TEXT COMPU LINK jacks.

- 1) **COMPU LINK-3 (SYNCHRO) jacks:** Use the cables with the monaural mini-plugs (not supplied with this receiver)

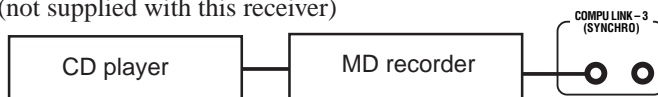

- 2) **TEXT COMPU LINK jacks:** Use the cables with the stereo mini-plugs (not supplied with this receiver)



IMPORTANT:

Set the Master/Slave Selector on the rear to "1(MASTER UNIT)."

- "2(SLAVE UNIT)" is just for the serviceman's use. The TEXT COMPU LINK remote control system does not function with the selector set to "2(SLAVE UNIT)."

3. Connect your CD player, MD recorder and this receiver, using the cables with RCA pin plugs (see page 14).
4. Plug the AC power cords of these components above into the AC outlets.
5. When turning on these components for the first time, turn on the connected components first, then turn on this receiver.

FUNCTIONS:

This remote control system allows you to use the functions listed below.

Displaying the Disc Information on the TV screen

Disc information such as its performer and disc title (and track titles only when a CD Text is selected) is shown on the TV screen.

Disc Search: Only for CD Player

This remote control system can allow you to search discs by the performer, disc title, and music genre.

With this disc search, you can easily find the disc you want to play.

Additional Functions:

- If your CD player has the User File function, you can select a disc from the groups.
* A "user file" is a group of the discs you make as you like on the CD player.
- If your CD player has the disc memory function, you can input the performer, disc title, and music genre about these normal audio CDs on the TV screen.

*What is a CD Text?

In a CD Text, some information about the disc (its disc title, performer, composer, arranger, etc.) is recorded.

Notes:

- If your audio component has two COMPU LINK-3 (SYNCHRO) jacks, you can use either one. If it has only one COMPU LINK-3 (SYNCHRO) jack, connect it so that it is the last item in the series of components. (For example, the CD player in the diagram to the left.)
- If your audio component has two TEXT COMPU LINK jacks, you can use either one. If it has only one TEXT COMPU LINK jack, connect it so that it is the last item in the series of components. (For example, the CD player in the diagram to the left.)
- Refer also to the manuals supplied with your CD player or MD recorder.

Note:

If you turn on the receiver before turning on the other components after connecting components, the TEXT COMPU LINK remote control system does not work correctly.

If this happens:

1. Turn off the all components including this receiver.
2. Turn on the connected components.
3. Turn on this receiver.

OPERATIONS

To use this remote control system, you need to connect the TV to the MONITOR OUT jack on the rear panel (see page 15), and set the TV's input mode to the proper position to which the receiver is connected. **Make sure you have connected the CD player or MD recorder equipped with the TEXT COMPU LINK remote control system. If not, you cannot use the following functions.**

Showing the Disc Information on the TV Screen

1. Press any button of ON SCREEN CONTROL $\Delta / \nabla / \triangleleft / \triangleright$ once. The MAIN MENU appears on the TV.
2. Press ON SCREEN CONTROL Δ / ∇ to move \square to "SOURCE."
3. Press ON SCREEN CONTROL $\triangleleft / \triangleright$ to select "CD" or "MD."
4. Press ON SCREEN CONTROL Δ / ∇ to move \square to "VISUAL."
5. Press ON SCREEN CONTROL $\triangleleft / \triangleright$ to select "OSD," then press EXIT. The Disc Information screen appears on the TV.

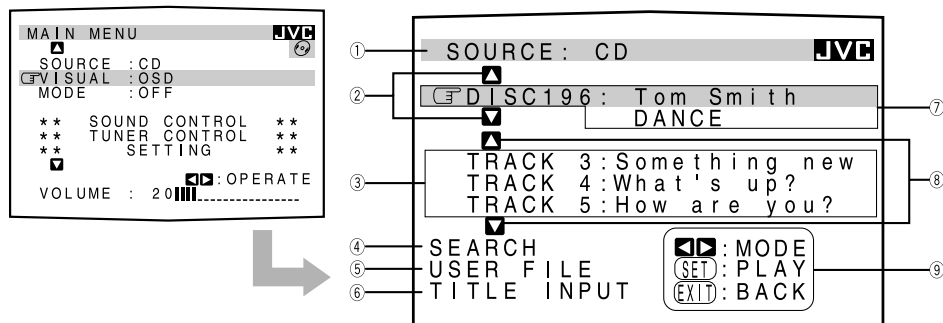

- ① Source name: CD or MD
 - ② Select \blacktriangle or \blacktriangledown , then press SET to change the disc.
 - ③ Track numbers and track titles.
 - The current playing (selected) track is indicated in yellow.
 - When you move \square to a track number, you can change the track information by pressing $\triangleleft / \triangleright$. Each time you press the button, track information alternates between its track title and its performer. (You can also start playing the track by pressing SET.)
 - ④ Select this (move \square in front), then press SET to go to the DISC SEARCH screen (see page 57).
 - ⑤ Select this (move \square in front), then press SET to go to the USER FILE screen (see page 59).
 - ⑥ Select this (move \square in front), then press SET to go to the TITLE INPUT screen (see page 60).
 - ⑦ Disc information such as the disc title, performer, and music genre. When this is selected (\square in front), you can change the disc information by pressing $\triangleleft / \triangleright$. Each time you press the button, disc information (see the note) changes.
 - ⑧ Select \blacktriangle or \blacktriangledown , then press SET to change the track.
 - ⑨ Usable buttons and their functions for the current selection. Indication here will be changed what is currently selected (\square in front) on the screen.
6. When you finish, press EXIT repeatedly until the MAIN MENU appears on the TV.

To exit from the MAIN MENU:

- 1) Press ON SCREEN CONTROL Δ / ∇ to move \square to "VISUAL."
- 2) Press ON SCREEN CONTROL $\triangleleft / \triangleright$ to select any one other than "OSD," then press EXIT.

Notes:

- The on-screen display will not appear about one minute after the power is turned on.
- The on-screen display will disappear in the following case:
 - if no operation is done for about 10 minutes.
 - if you do any operation other than explained in this section.
- To control the MD recorder using the TEXT COMPU LINK remote control system, you have to change the source name shown on the display from "TAPE" to "MD." (See page 23.)
- The number of characters to show the disc information such as the disc title or track title is limited to 32. So if the disc title, for example, is longer than 32 characters, only the first 32 characters are shown.
- Some special characters such as accented letters cannot be displayed correctly.

Note on ⑦:

The following information will appear on the display:

- Disc title
- Performer
- Genre
- Song writer
- Composer
- Arranger
- Message

Only recorded information will be shown. If there is no data, "NO DATA" will appear.

Note on ⑨:

For example, the SET button will be used to start play (PLAY), to go to the next screen (ENTER), and to determine the selection (ENTER).

TEXT COMPU LINK Remote Control System

■ Searching a Disc (Only for the CD player)

Search a disc by its performer:

1. Display the disc information screen by following the procedure on page 56.
2. Press ON SCREEN CONTROL Δ / ∇ to move \square to "SEARCH," then press SET.
The DISC SEARCH screen appears on the TV.
3. Press ON SCREEN CONTROL Δ / ∇ to move \square to "PERFORMER", then press SET.
The PERFORMER SEARCH screen appears.
4. Press ON SCREEN CONTROL $\Delta / \nabla / \triangleleft / \triangleright$ to move \square in front of the first character of the performer you want to search, then press SET.

To correct the incorrect entry, press ON SCREEN CONTROL Δ / ∇ to move \square in front of the correct character, then press SET.

To erase the incorrect entry, press ON SCREEN CONTROL Δ / ∇ to move \square to CANCEL, then press SET.
5. Press SET again.
Disc search starts, then the SEARCH RESULT screen, showing the performers, appears.
6. On the SEARCH RESULT screen, you can do the following:
 - **Changing the indication of the disc information:** Press ON SCREEN CONTROL Δ / ∇ to move \square to a searched disc, then press $\triangleleft / \triangleright$. Each time you press $\triangleleft / \triangleright$, the disc information alternates between its performer and its disc title.
 - **Going to the Disc Information screen (see page 56):** Press ON SCREEN CONTROL Δ / ∇ to move \square to a searched disc, then press SET.
 - **Showing unseen disc information** (if more than 5 discs are listed as a result of the search): Press ON SCREEN CONTROL Δ / ∇ to move \square to \blacktriangledown (or \blacktriangle), then press SET.
 - **Going back to the PERFORMER SEARCH screen:** Press EXIT.

Search a disc by its disc title:

1. Display the disc information screen by following the procedure on page 56.
2. Press ON SCREEN CONTROL Δ / ∇ to move \square to "SEARCH," then press SET.
The DISC SEARCH screen appears on the TV.
3. Press ON SCREEN CONTROL Δ / ∇ to move \square to "DISC TITLE", then press SET.
The DISC TITLE SEARCH screen appears.
4. Press ON SCREEN CONTROL $\Delta / \nabla / \triangleleft / \triangleright$ to move \square in front of the first character of the disc title you want to search, then press SET.

To correct the incorrect entry, press ON SCREEN CONTROL Δ / ∇ move \square in front of the correct character, then press SET.

To erase the incorrect entry, press ON SCREEN CONTROL Δ / ∇ move \square to CANCEL, then press SET.

DISC SEARCH screen

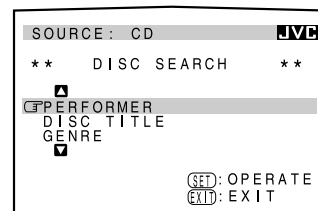

PERFORMER SEARCH screen

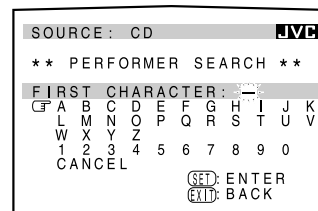

SEARCH RESULT screen

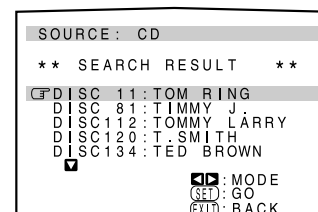

Note:

Symbols such as @, # or \$ cannot be available for search.

DISC SEARCH screen

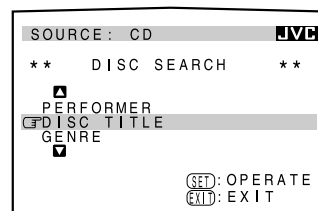

DISC TITLE SEARCH screen

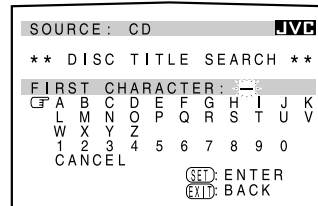

5. Press SET again.

Disc search starts, then the SEARCH RESULT screen, showing the disc titles, appears.

6. On the SEARCH RESULT screen, you can do the following:

- **Changing the indication of the disc information:** Press ON SCREEN CONTROL Δ / ∇ to move ⏏ to a searched disc, then press $\triangleleft / \triangleright$. Each time you press $\triangleleft / \triangleright$, the disc information alternates between its disc title and its performer.
- **Going to the Disc Information screen (see page 56):** Press ON SCREEN CONTROL Δ / ∇ to move ⏏ to a searched disc, then press SET.
- **Showing unseen disc information** (if more than 5 discs are listed as a result of the search): Press ON SCREEN CONTROL Δ / ∇ to move ⏏ to \blacktriangledown (or \blacktriangle), then press SET.
- **Going back to the DISC TITLE SEARCH screen:** Press EXIT.

Search a disc by its genre:

1. Display the disc information screen by following the procedure on page 56.

2. Press ON SCREEN CONTROL Δ / ∇ to move ⏏ to “SEARCH,” then press SET.

The DISC SEARCH screen appears on the TV.

3. Press ON SCREEN CONTROL Δ / ∇ to move ⏏ to “GENRE”, then press SET.

The GENRE SEARCH screen appears.

4. Press ON SCREEN CONTROL Δ / ∇ to move ⏏ to the genre you want to search, then press SET.

To show the unseen genres, press ON SCREEN CONTROL Δ / ∇ until they appear.

Disc search starts, then the SEARCH RESULT screen, showing the disc titles, appears.

5. On the SEARCH RESULT screen, you can do the following:

- **Changing the indication of the disc information:** Press ON SCREEN CONTROL Δ / ∇ to move ⏏ to a searched disc, then press $\triangleleft / \triangleright$. Each time you press $\triangleleft / \triangleright$, the disc information alternates between its disc title and its performer.
- **Going to the Disc Information screen (see page 56):** Press ON SCREEN CONTROL Δ / ∇ to move ⏏ to a searched disc, then press SET.
- **Showing unseen disc information** (if more than 5 discs are listed as a result of the search): Press ON SCREEN CONTROL Δ / ∇ to move ⏏ to \blacktriangledown (or \blacktriangle), then press SET.
- **Going back to the GENRE SEARCH screen:** Press EXIT.

SEARCH RESULT screen

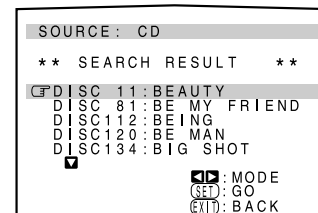

Note:

Symbols such as @, # or \$ cannot be available for search.

GENRE SEARCH screen

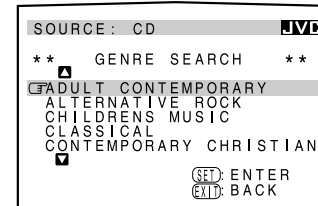

SEARCH RESULT screen

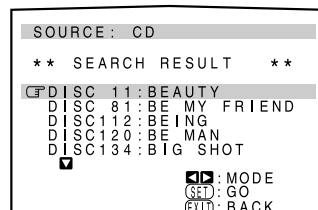

TEXT COMPU LINK Remote Control System

Using the User File (Only for the CD Player with the User File Function)

You can use the User File function through this receiver.

For the User File function, refer to the manual supplied with your CD player.

Using your own User Files:

1. Display the disc information screen by following the procedure on page 56.

2. Press ON SCREEN CONTROL Δ / ∇ to move \square to "USER FILE," then press SET.

The USER FILE screen appears on the TV.

To show the unseen user files, press ON SCREEN CONTROL Δ / ∇ until they appear.

3. Press ON SCREEN CONTROL Δ / ∇ to move \square to the User File you want, then press SET.

The selected User File screen appears on the TV.

The disc information shown will be the disc title. (If no disc title information is recorded for the discs, only the disc numbers will be shown.)

4. On this selected User File screen, you can do the following:

- **Changing the indication of the disc information:** Press ON SCREEN CONTROL Δ / ∇ to move \square to a disc, then press $\triangleleft / \triangleright$. Each time you press $\triangleleft / \triangleright$, the disc information alternates between its disc title and its performer.
- **Starting a disc play:** Press ON SCREEN CONTROL Δ / ∇ to move \square to a disc, then press SET.
- **Showing unseen disc information** (if more than 5 discs are listed): Press ON SCREEN CONTROL Δ / ∇ to move \square to \blacktriangledown (or \blacktriangle) and press SET.
- **Going back to the USER FILE screen:** Press EXIT.

USER FILE screen

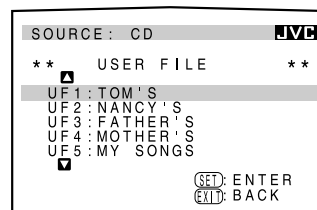

User File 1 screen

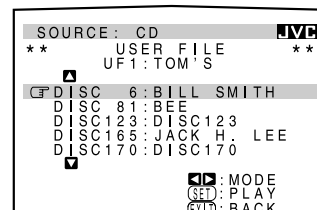

Entering the Disc Information

For the CD Player with the disc memory function:

You can use the disc memory function through this receiver.

The disc information (its performer, disc title, and its music genre) of normal audio CDs will be stored into the memory built in the CD player.

For the disc memory function, refer to the manual supplied with your CD player.

- The performer, disc title, and music genre information are usually recorded in a CD Text. However, if a CD Text has no genre information recorded in the disc itself, you can input its music genre by yourself.

Note: You can enter the TITLE INPUT screens for a CD Text and input its titles.

However, **you cannot store the titles you have input for a CD Text.**

Example: Entering the following information for Disc 1
Performer: "MICHEAL"
Disc title: "MY FAVORITE"

- Display the disc information screen by following the procedure on page 56.
- Press ON SCREEN CONTROL Δ / ∇ to move C to "TITLE INPUT," then press SET.
The TITLE INPUT: PERFORMER screen appears on the TV.
- Press ON SCREEN CONTROL $\Delta / \nabla / \triangleleft / \triangleright$ to move C in front of a character you want, then press SET to enter the character.
 - If the current CD is a CD Text, go to step 5 without entering the performer.

To use the lower case letters, press ON SCREEN CONTROL $\Delta / \nabla / \triangleleft / \triangleright$ to move C to [SHIFT] , then press SET.

To use the upper case letters again, press ON SCREEN CONTROL $\Delta / \nabla / \triangleleft / \triangleright$ to move C to [SHIFT] , then press SET.

- Repeat step 3 until you finish putting a name (up to 32 characters) to this User File.

To insert a space, press ON SCREEN CONTROL $\Delta / \nabla / \triangleleft / \triangleright$ to move C to [SPACE] , then press SET.

To correct an incorrect character:

- Press ON SCREEN CONTROL $\Delta / \nabla / \triangleleft / \triangleright$ to move C to [LEFT] or [RIGHT] , then press SET until the incorrect character is selected.
 - Press ON SCREEN CONTROL $\Delta / \nabla / \triangleleft / \triangleright$ to move C to CANCEL, then press SET to erase the character.
 - Press ON SCREEN CONTROL $\Delta / \nabla / \triangleleft / \triangleright$ to move C in front of a correct character, then press SET to enter a correct character.
- Press ON SCREEN CONTROL $\Delta / \nabla / \triangleleft / \triangleright$ to move C to "DISC1: MICHEAL (in this example)," then press SET.
The TITLE INPUT: DISC TITLE screen appears.
 - Enter the disc title, referring to steps 3 and 4.
 - If the current CD is a CD Text, go to the next step without entering the disc title.

TITLE INPUT: PERFORMER screen

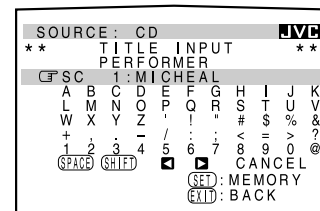
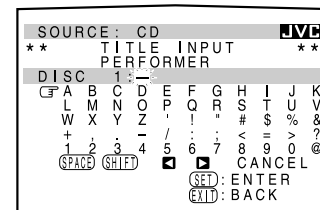

TITLE INPUT: DISC TITLE screen

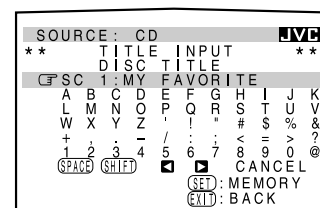
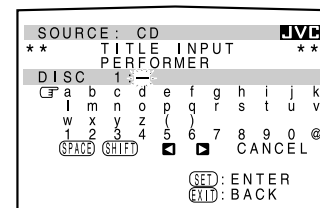
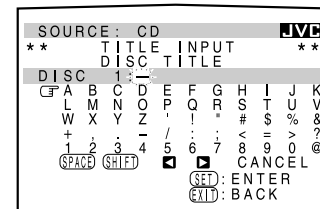

Continued to the next page.

TEXT COMPU LINK Remote Control System

7. Press ON SCREEN CONTROL $\Delta / \nabla / \triangleleft / \triangleright$ to move F to "DISC1: MY FAVORITE (in this example)," then press SET.

The TITLE INPUT: DISC 1 GENRE screen appears.

8. Press ON SCREEN CONTROL Δ / ∇ to move F to the genre you want, then press SET.

The Disc Information screen appears again.

To show the unseen genres, press ON SCREEN CONTROL Δ / ∇ until they appear.

For the MD recorder:

You can write the disc information (disc title and song titles) into the disc. You can only write the song title for the song currently selected.

- If you have the CD-MD combination deck, you can also enter the disc information (its performer, disc title, and its music genre) of normal audio CDs into the memory built in the CD-MD combination deck. (To do this, follow the procedure on page 60.)

1. Display the disc information screen by following the procedure on page 56.

2. Press ON SCREEN CONTROL Δ / ∇ to move F to "TITLE INPUT," then press SET.

The DISC TITLE INPUT screen appears on the TV.

3. Enter the title, referring to steps 3 and 4 on page 60.

- You can enter up to 32 character for the disc title.

4. Press ON SCREEN CONTROL $\Delta / \nabla / \triangleleft / \triangleright$ to move F to the disc title you have just entered, then press SET.

The disc title is stored into the memory, and the SONG TITLE INPUT screen for the currently selected song appears.

- You can enter a song title for the song currently selected (indicated in yellow on the TV screen).

5. Enter the song title, referring to steps 3 and 4 on page 60.

- You can enter up to 32 character for the song title.

6. Press ON SCREEN CONTROL $\Delta / \nabla / \triangleleft / \triangleright$ to move F to the song title you have just entered, then press SET.

The song title is stored into the memory, and the Disc Information screen appears again.

TITLE INPUT: DISC 1 GENRE screen

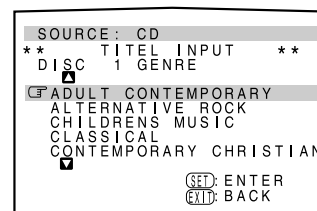

Disc Information screen

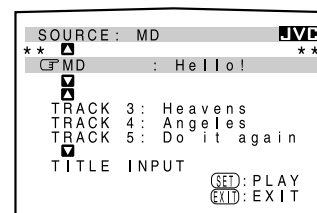

DISC TITLE INPUT screen

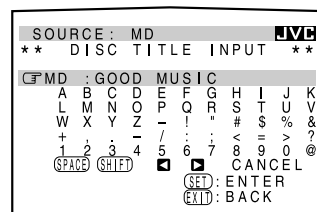
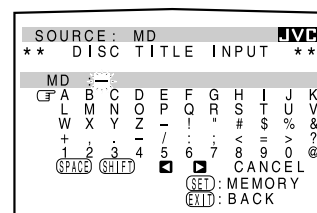

Operating JVC's Audio/Video Components

You can operate JVC's audio and video components with this receiver's remote control, since control signals for JVC components are preset in the remote control.

IMPORTANT:

To operate JVC's audio components using this remote control:

- You need to connect JVC audio components through the COMPU LINK-3 (SYNCHRO) jacks (see page 54) in addition to the connections using cables with RCA pin plugs (see page 14).
- Aim the remote control directly at the remote sensor on the receiver.

Tuner

After pressing FM/AM (with the remote control mode selector set to "AUDIO/TV/VCR"), you can perform the following operations:

- FM/AM:** Alternates between FM and AM.
- 1 — 10, +10:** Selects a preset channel number directly. For channel number 5, press 5. For channel number 15, press +10, then 5. For channel number 20, press +10, then 10.

TUNING UP/TUNING DOWN:

Tunes into stations.

FM MODE/MUTE: Changes the FM reception mode.

Sound control section (Amplifier)

You can always perform the following operations (with the remote control mode selector set to "AUDIO/TV/VCR"):

- SEA MODE:** Changes the SEA modes.
- SURROUND MODE:** Changes the DSP modes.

After pressing SOUND CONTROL (with the remote control mode selector set to "AUDIO/TV/VCR"), you can perform the following operations:

- CNTR +/-:** Adjusts the center speaker output level for the Surround/DVD MULTI playback modes.
- REAR•(L) +/-:** Adjusts the left/right rear speaker output level for the DSP modes.
Adjusts the left rear speaker output level for the DVD MULTI playback mode.
- (REAR•R) +/-:** Adjusts the right rear speaker output level for the DVD MULTI playback mode.
- DELAY:** Selects the delay time of the rear speaker sound.
- EFFECT:** Selects the effect level for the DSP modes.
- TEST:** Turns on or off the test tone output for the Surround mode.
- CNTR TONE:** Selects the center tone level for the Surround/DVD MULTI playback modes.

CD player

After pressing CD (with the remote control mode selector set to "AUDIO/TV/VCR"), you can perform the following operations on a CD player:

- PLAY:** Starts playing.
- ◀◀:** Returns to the beginning of the current (or previous) track.
- ▶▶:** Skips to the beginning of the next track.
- STOP:** Stops playing.
- PAUSE:** Pauses playing. To release it, press PLAY.
- 1 — 10, +10:** Selects a track number directly. For track number 5, press 5. For track number 15, press +10, then 5. For track number 20, press +10, then 10. For track number 30, press +10, +10, then 10.

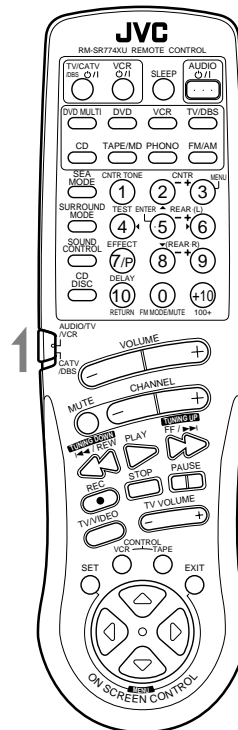

Notes:

- If you use the buttons on the front panel or the menu function to choose a source, the remote control will not operate that source. To operate a source with the remote control, the source must be selected using buttons on the remote control.
- Check to see if its remote control mode selector is set to the correct position. To operate audio system, TVs, and VCRs, set it to "AUDIO/TV/VCR."
- Refer also to the manuals supplied with your components.

Note:

After adjusting sounds, press the corresponding source selecting button or CD DISC to operate your target source by using 10 keys; otherwise, 10 keys cannot be used for operating your target source.

Operating JVC's Audio/Video Components

CD player-changer

After pressing CD DISC (with the remote control mode selector set to "AUDIO/TV/VCR"), you can perform the following operations on a CD player-changer:

- PLAY:** Starts playing.
◀◀: Returns to the beginning of the current (or previous) track.
▶▶: Skips to the beginning of the next track.
STOP: Stops playing.
PAUSE: Pauses playing. To release it, press the PLAY button.
1 — 6, 7/P: Select the number of a disc installed in a CD player-changer.

After pressing CD (with the remote control mode selector set to "AUDIO/TV/VCR"), you can perform the following operations on the CD player-changer:

- 1 — 10, +10:** Selects a track number directly.
 For track number 5, press 5. For track number 15, press +10, then 5. For track number 20, press +10, then 10. For track number 30, press +10, +10, then 10.

Turntable

After pressing PHONO (with the remote control mode selector set to "AUDIO/TV/VCR"), you can perform the following operations on a turntable:

- PLAY:** Starts playing.
STOP: Stops playing.

Cassette deck

After pressing TAPE/MD or TAPE CONTROL (with the remote control mode selector set to "AUDIO/TV/VCR"), you can perform the following operations on a cassette deck:

- PLAY:** Starts playing.
REW: Fast winds the tape from right to left.
FF: Fast winds the tape from left to right.
STOP: Stops operations.
PAUSE: Pauses playing or recording temporarily. To release it, press the PLAY button.
REC ●: Press this button with the PLAY button to start recording.
 Press this button with the PAUSE button to enter recording pause.

MD recorder

After pressing TAPE/MD or TAPE CONTROL (with the remote control mode selector set to the "AUDIO/TV/VCR" position), you can perform the following operations on the MD recorder:

- PLAY:** Starts playing.
◀◀: Returns to the beginning of the current (or previous) track.
▶▶: Skips to the beginning of the next track.
STOP: Stops playing.
PAUSE: Pauses playing. To release it, press the PLAY button.
REC ●: Press this button with the PLAY button to start recording.
 Press this button with the PAUSE button to enter recording pause.

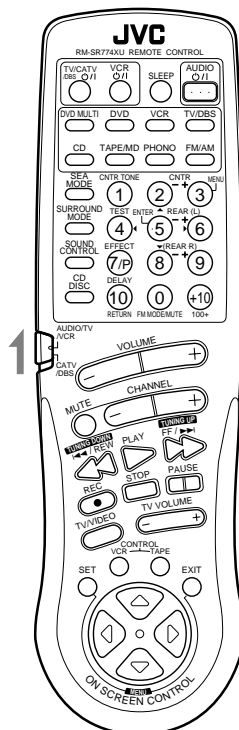

Notes:

- To operate the cassette deck or MD recorder using the COMPU LINK remote control system, set the source name correctly. (See page 23.)
- You can use either the TAPE/MD button or the TAPE CONTROL button to activate the buttons listed to the left. If you press TAPE/MD, the playing source also changes. On the other hand, if you press TAPE CONTROL, the playing source does not change.

IMPORTANT:

To operate JVC's video components using this remote control:

- Aim the remote control directly at the remote sensor on the VCR, DVD player or TV, not on the receiver.
- Some JVC VCRs can accept two types of the control signals — remote code "A" and "B." Before using this remote control, make sure that the remote control code of the VCR connected to the VCR jacks is set to code "A."

VCR

You can always perform the following operations (*with the remote control mode selector set to "AUDIO/TV/VCR"*):

VCR \odot/I : Turns on or off the VCR.

After pressing VCR or VCR CONTROL (*with the remote control mode selector set to "AUDIO/TV/VCR"*), you can perform the following operations on the VCR:

- PLAY:** Starts playing.
- REW:** Rewinds a tape.
- FF:** Fast winds a tape.
- STOP:** Stops operations.
- PAUSE:** Pauses playing or recording temporarily. To release it, press the PLAY button.
- REC** \bullet : Press this button with the PLAY button to start recording.
Press this button with the PAUSE button to enter recording pause.
- CHANNEL +/-:** Changes the channels on the VCR.
- 1 – 9, 0:** Selects the channels on the VCR.
For channel 5, press 5.
For channel 10, press 1, then 0.

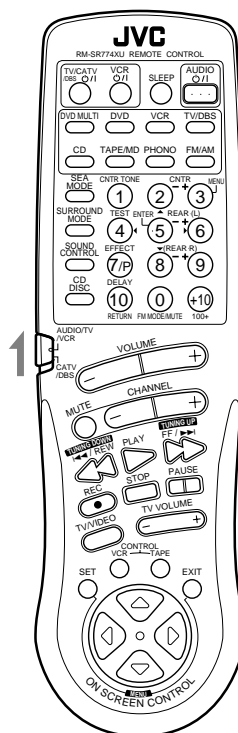
**Note:**

You can use either the VCR button or the VCR CONTROL button to activate the buttons listed to the left. If you press VCR, the playing source also changes. On the other hand, if you press VCR CONTROL, the playing source does not change.

DVD player

After pressing DVD or DVD MULTI (*with the remote control mode selector set to "AUDIO/TV/VCR"*), you can perform the following operations on a DVD player:

- PLAY:** Starts playing.
- ◀◀:** Returns to the beginning of the current (or previous) track.
- ▶▶:** Skips to the beginning of the next track.
- STOP:** Stops playing.
- PAUSE:** Stops playing temporarily. To release it, press the PLAY button.

TV

You can always perform the following operations (*with the remote control mode selector set to "AUDIO/TV/VCR"*):

- TV/CATV/DBS** \odot/I : Turns on or off the TV.
- TV VOLUME +/-:** Adjusts the volume.
- TV/VIDEO:** Sets the input mode (either TV or VIDEO).

After pressing TV/DBS (*with the remote control mode selector set to "AUDIO/TV/VCR"*), you can perform the following operations on a TV:

- CHANNEL +/-:** Changes the channels.
- 1 – 9, 0, 100+:** Selects the channels.
- RETURN:** Alternates between the previously selected channel and the current channel.

After pressing DVD or DVD MULTI (*with the remote control mode selector set to the "AUDIO/TV/VCR" position*), these buttons can be used for the DVD menu operations.

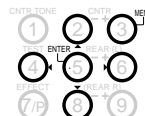
**Note:**

For detailed menu operations, refer to the instructions supplied with the discs or the DVD player.

Operating Other Manufactures' Components

This remote control supplied with the receiver can transmit control signals for other manufacturers' VCRs, TVs, CATV converters and DBS tuners. By changing the transmittable signals from preset ones to the other manufacturers', you can operate the other manufacturer's components using this remote control.

When operating the other manufacturers' components, refer also to the manuals supplied with them.

To operate these components with the remote control, first you need to set the manufacturer's code each for the VCR, TV, CATV converter, and DBS tuner.

IMPORTANT:



When using the Remote Control, check to see if its remote control mode selector is set to the correct position:

To operate an audio system, TV, and VCR, set it to "AUDIO/TV/VCR."

To operate a CATV converter and DBS tuner, set it to "CATV/DBS."

To change the transmittable signals for operating another manufacturer's TV

1. Set the remote control mode selector to "AUDIO/TV/VCR."
2. Press and hold TV/CATV/DBS \odot/I .
3. Press TV/DBS.
4. Enter the manufacturer's code (three digits) using buttons 1 – 9, and 0.
See the lists on page 68 to find the code.
5. Release TV/CATV/DBS \odot/I .

The following buttons can be used for operating the TV (with the remote control mode selector set to "AUDIO/TV/VCR"):

- | | |
|---|---|
| TV/CATV/DBS \odot/I: | Turns on and off TV. |
| TV VOLUME +/-: | Adjusts the volume. |
| TV/VIDEO: | Sets the input mode (either TV or VIDEO). |

After pressing TV/DBS (with the remote control mode selector set to "AUDIO/TV/VCR"), you can perform the following operations on the TV:

- | | |
|------------------------------|---|
| CHANNEL +/-: | Changes the channels. |
| 1 – 10, 0, 100+(+10): | Selects the TV channels.
100+(+10) button will function as the ENTER button if your TV requires pressing ENTER after selecting a channel number. |

6. Try to operate your TV by pressing TV/CATV/DBS \odot/I .
When your TV turns on or off, you have entered the correct code.
7. If there are more than one code listed for your brand of TV, try each one until the correct one is entered.

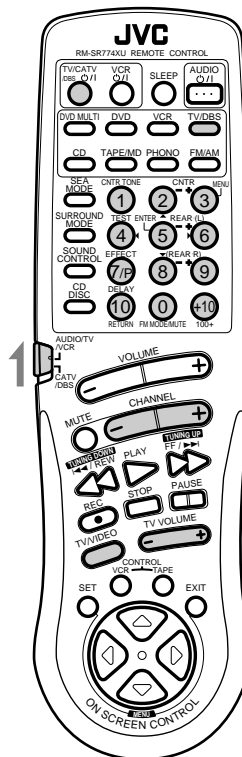

Note:

Refer also to the manual supplied with your TV.

To change the transmittable signals for operating a CATV converter or DBS tuner

1. Set the remote control mode selector to “CATV/DBS.”

2. Press and hold TV/CATV/DBS \cup/\downarrow .

3. Press TV/DBS.

4. Enter the manufacturer’s code (three digits) using buttons 1 – 9, and 0.

See the lists on page 68 to find the code.

5. Release TV/CATV/DBS \cup/\downarrow .

After setting the remote control mode selector to “CATV/DBS,” you can perform the following operations on the CATV converter or on the DBS tuner:

TV/CATV/DBS \cup/\downarrow : Turns on and off the CATV converter or DBS tuner.

CHANNEL +/-: Changes the channels.

1 – 10, 0, 100+(+10): Selects the channels. 100+(+10) button will function as the ENTER button if your CATV converter or DBS tuner requires pressing ENTER after selecting a channel number.

6. Try to operate your CATV converter or DBS tuner by pressing TV/CATV/DBS \cup/\downarrow .

When your CATV converter or DBS tuner turns on or off, you have entered the correct code.

7. If there are more than one code listed for your brand of CATV converter or DBS tuner, try each one until the correct one is entered.

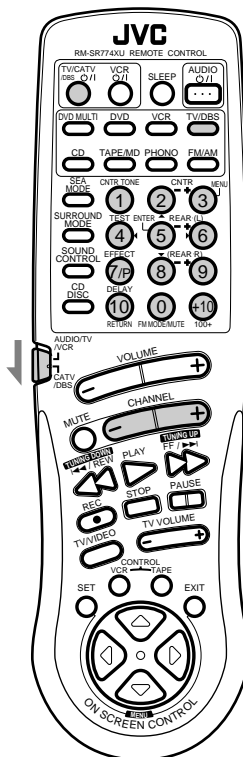

Note:

Refer also to the manual supplied with your CATV converter or DBS tuner.

Operating Other Manufactures' Components

To change the transmittable signals for operating another manufacturer's VCR

1. Set the remote control mode selector to "AUDIO/TV/VCR."
2. Press and hold VCR \cup/\downarrow .
3. Press VCR.
4. Enter the manufacturer's code (three digits) using buttons 1 – 9, and 0.
See the lists on page 69 to find the code.
5. Release VCR \cup/\downarrow .
The following buttons can be used for operating the VCR (with the remote control mode selector set to "AUDIO/TV/VCR"):
VCR \cup/\downarrow : Turns on and off VCR.

After pressing VCR or VCR CONTROL (with the remote control mode selector set to "AUDIO/TV/VCR"), you can perform the following operations on the VCR:

- CHANNEL +/-:** Changes the channels on the VCR.
1 – 10, 0, 100+(+10): Selects the channels on the VCR. 100+(+10) button will function as the ENTER button if your VCR requires pressing ENTER after selecting a channel number.
- PLAY:** Starts playback.
STOP: Stops operations.
PAUSE: Pauses.
REW: Rewinds a tape.
FF: Fast winds a tape.
REC ●: Starts recording or enters recording pause.

6. Try to operate your VCR by pressing VCR \cup/\downarrow .
When your VCR turns on or off, you have entered the correct code.
7. If there are more than one code listed for your brand of VCR, try each one until the correct one is entered.

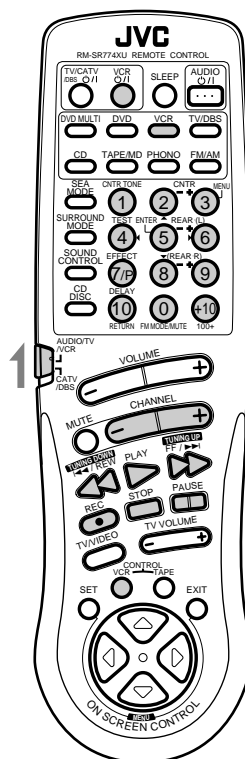

Notes:

- You can use either the VCR button or the VCR CONTROL button to activate the buttons listed to the left. If you press VCR, the playing source also changes. On the other hand, if you press VCR CONTROL, the playing source does not change.
- Refer also to the manual supplied with your VCR.

Manufacturers' codes for TV

Anam	003, 004, 009, 068, 161, 425, 426
Anam National	161, 250, 425
Blaupunkt	554
Daewoo	066, 092, 154, 391, 402, 451
ECE	037
Etron	009, 283
Fortress	093
Funai	264, 342
General	186
GoldStar	002, 037, 039, 178, 283, 457, 467
Grundig	535
Hitachi	145
JVC	036, 053, 069, 094, 160
Marantz	054
Matsushita	250
Mitsubishi	150, 241
National	226
NEC	030, 170
Nicamagic	216
Panasonic	161, 250
Philips	037
Pioneer	166
Samsung	060, 090, 427
Sanyo	208, 376, 424
Sharp	093, 256
Sony	000
Telefunken	252
Thomson	560
Toshiba	156, 502
Victor	036, 053, 160, 250, 376

Manufacturers' codes for CATV converters

Daeryung	008
GoldStar	838
LG Alps	779
Now	776
Samsung	702
Seawoo	780
Tongkook	777, 840
Zenith	000

Manufacturers' codes for DBS tuner

Dae Young	735
DX Antenna	752
Marantz	200
Panasonic	739
Pantech	747
Samsung	773
Sony	661
Toshiba	486

Operating Other Manufactures' Components

Manufacturers' codes for VCR

Akai	281, 288
Anam	037, 162, 226, 240, 278
Anam National	162, 226
Blaupunkt	226
Daewoo	020, 046, 278, 368, 552
Funai	000
General	052
GoldStar	037, 225, 471
Grundig	195
Hitachi	042, 166, 235
JVC	008, 041, 067, 384
Marantz	081
Matsushita	227
Mitsubishi	043, 061, 196
National	226
NEC	038, 040, 370
Panasonic	162, 226, 227, 367
Philips	062, 081
Pioneer	058
Samsung	240, 426, 432
Sanyo	046, 104, 368, 369
Sharp	048, 062, 363
Shintom	072
Sony	032, 033, 034
Telefunken	187
Thomson	320
Toshiba	045, 366
Victor	008, 041, 067, 384

Manufacturers' codes listed on pages 68 and 69 are subject to change without notice. If they are changed, this remote control cannot operate the equipment.

Troubleshooting

Use this chart to help you solve daily operational problems. If there is any problem you cannot solve, contact your JVC service center.

PROBLEM	POSSIBLE CAUSE	SOLUTION
The display does not light up.	The power cord is not plugged in or the ⓪ POWER switch pressed to set it in the ■ OFF position.	Plug the power cord into an AC outlet and/or press ⓪ POWER to set it in the ■ ON position.
No sound from speakers.	Speaker signal cables are not connected.	Check speaker wiring and reconnect if necessary.
	The SPEAKERS 1 and 2 buttons are not set correctly.	Press SPEAKERS 1 and 2 correctly.
	An incorrect source is selected.	Select the correct source.
	Muting is activated.	Press MUTE to cancel the mute.
Sound from one speaker only.	Speaker signal cables are not connected properly.	Check speaker wiring and reconnect if necessary.
	The balance is set to one extreme.	Adjust the balance properly (see page 23).
Continuous hiss or buzzing during FM reception.	Incoming signal is too weak.	Connect an outside FM antenna or contact your dealer.
	The station is too far away.	Select a new station.
	An incorrect antenna is used.	Check with your dealer to be sure you have the correct antenna.
	Antennas are not connected properly.	Check connections.
Occasional cracking noise during FM reception.	Ignition noise from automobiles.	Move the antenna farther from automobile traffic.
No colors on the on-screen display.	The color system of the connected TV is not PAL.	Connect a PAL TV.
Howling during record playing.	Your turntable is too close to speakers.	Move speakers away from the turntable.
"OVERLOAD" starts flashing on the display.	Speakers are overloaded because of high volume.	Rotate the MASTER VOLUME control counterclockwise three or four times, then press STANDBY/ON ⓪ /I on the front panel. If "OVERLOAD" does not disappear, unplug the AC power cord, then plug it back again.
	Speakers are overloaded because of short circuit of speaker terminals.	Press STANDBY/ON ⓪ /I on the front panel, then check the speaker wiring. If "OVERLOAD" does not disappear, unplug the AC power cord, then plug it back again. If speaker wiring is not short-circuited, contact your dealer.
Remote control does not work.	The remote control mode selector is not set correctly.	Set the selector correctly either to "AUDIO/TV/VCR" or to "CATV/DBS."
	There is an obstruction in front of the remote sensor on the receiver.	Remove the obstruction.
	Batteries are weak.	Replace batteries.

Specifications

Amplifier

Output Power	At Stereo operation	100 watts per channel, min. RMS, driven into 4 ohms, at 1 kHz with no more than 0.7 % total harmonic distortion. (IEC268-3/DIN)
		50 watts per channel, min. RMS, driven into 8 ohms, at 1 kHz with no more than 0.7 % total harmonic distortion. (IEC268-3/DIN)
	At Surround operation	
	Front Channels	70 watts per channel, min. RMS, driven into 4 ohms at 1 kHz with no more than 0.8 % total harmonic distortion.
	Center channel	70 watts, min. RMS, driven into 4 ohms at 1 kHz, with no more than 0.8 % total harmonic distortion.
	Rear channels	70 watts per channel, min. RMS, driven into 4 ohms at 1kHz, with no more than 0.8 % total harmonic distortion.
Total Harmonic Distortion (8 ohms, 1 kHz)		0.02 %* at 50 watts output (* Measured by JVC Audio Analysis System)
Audio Input Sensitivity/Impedance (1 kHz)	PHONO (MM)	2.5 mV/47 k ohms
	CD, TAPE/MD, TV SOUND/DBS, VCR, DVD	200 mV/47 k ohms
Audio Output Level	TAPE/MD, VCR	200 mV
Signal-to-Noise Ratio (ˆ66 IHF/DIN)	PHONO	70 dB/66 dB
	CD, TAPE/MD, TV SOUND/DBS, VCR, DVD	87 dB/67 dB
Frequency Response (8 ohms)	PHONO	20 Hz to 20 kHz (±1 dB)
	CD, TAPE/MD, TV SOUND/DBS, VCR, DVD	20 Hz to 20 kHz (±1 dB)
RIAA Phono Equalization		±0.5 dB (20 Hz to 20 kHz)
Loudness Control (Volume Control at -30 dB)		+6 ±1 dB at 100 Hz +4 ±1 dB at 10 kHz
S.E.A.	Center Frequencies	100 Hz, 1 kHz, 10 kHz
	Control Range	±10 dB ±2 dB

Video

Video Input Sensitivity/Impedance	Composite video: TV SOUND/DBS, VCR, DVD	1 Vp-p/75 ohms
	S-video: DVD	
	(Y: luminance):	1 Vp-p/75 ohms
	(C: chrominance, burst):	0.286 Vp-p/75 ohms
Video Output Level	Composite video: VCR, MONITOR OUT	1 Vp-p/75 ohms
	S-video: MONITOR OUT	1 Vp-p/75 ohms
	(Y: luminance):	1 Vp-p/75 ohms
	(C: chrominance, burst):	0.286 Vp-p/75 ohms
Synchronization		Negative
Signal-to-Noise Ratio		45 dB
On-Screen Color System		PAL

FM tuner (IHF)

Tuning Range		87.5 MHz to 108.0 MHz
Usable Sensitivity	Monaural	12.7 dBf (1.2 μ V/75 ohms)
50 dB Quieting Sensitivity	Monaural	16.3 dBf (1.8 μ V/75 ohms)
	Stereo	38.3 dBf (22.5 μ V/75 ohms)
Signal-to-Noise Ratio (IHF-A weighted)	Monaural	80 dB at 85 dBf
	Stereo	73 dB at 85 dBf
Total Harmonic Distortion	Monaural	0.15 % at 1 kHz
	Stereo	0.2 % at 1 kHz
Stereo Separation at REC OUT		40 dB at 1 kHz
Capture Ratio		1.5 dB at 85 dBf
Alternate Channel Selectivity		60 dB: (\pm 400 kHz)
Frequency Response		30 Hz to 15 kHz: (+0.5 dB, -3 dB)

AM tuner

Tuning Range		531 kHz to 1,602 kHz (at 9 kHz interval)
		530 kHz to 1,600 kHz (at 10 kHz interval)
Usable Sensitivity	Loop antenna	300 μ V/m
Signal-to-Noise Ratio		50 dB (100 mV/m)

General

Power Requirements		AC 110/127/220/230-240V [^] , adjustable with the voltage selector, 50/60 Hz
Power Consumption		280 watts 2 watts (in standby mode)
Dimensions (W x H x D)		435 x 157 x 412.5 mm (17 ³ / ₁₆ x 6 ³ / ₁₆ x 16 ¹ / ₄ inches)
Mass		11.3 kg (25.0 lbs)

Designs & specifications are subject to change without notice.

Mains (AC) Line Instruction (not applicable for Europe, U.S.A., Canada, Australia and U.K.)

Instrucción sobre la línea de la red (CA) (no aplicable para Europa, EE.UU., Canadá, Australia, ni el Reino Unido)

Instrução sobre a tensão da rede eléctrica (CA) (não aplicável para a Europa, os E.U.A., o Canadá, a Austrália e o Reino Unido)

主 (AC) 電源線路說明 (不適用於歐洲、美國、加拿大、澳洲及英國型號)

تعليمات التيار الرئيسي (التردد) (لا ينطبق لأوروبا وأمريكا وكندا وأستراليا والمملكة المتحدة)

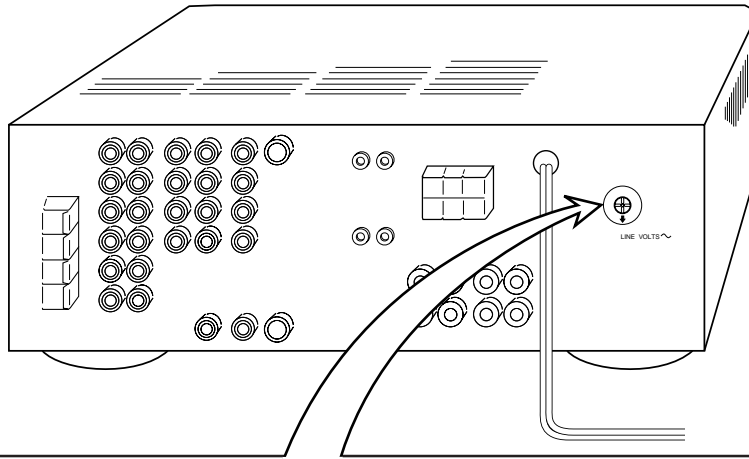

IMPORTANT for mains (AC) line

BEFORE PLUGGING IN, do check that your mains (AC) line voltage corresponds with the position of the voltage selector switch provided on the outside of this equipment and, if different, reset the voltage selector switch, to prevent from a damage or risk of fire/electric shock.

有關主(AC)電源線路的重要事項

接插電源以前，務請檢查當地的主(AC)電源線路電壓是否和位於本機外面的電壓選擇開關設定的位置一致。如果不一致，即重新設定電壓選擇開關使符合當地電壓，以免損壞機器或引起火災/觸電的危險。

IMPORTANTE para la línea de la red (CA)

ANTES DE ENCHUFAR EL EQUIPO, compruebe si la tensión de la línea de la red (CA) corresponde con la posición del selector de tensión situado en la parte exterior del equipo, y si es diferente, reajuste el selector de tensión para evitar el riesgo de incendios/ descargas eléctricas.

هام من أجل خط التيار المتردد (AC) الرئيسي

قبل ادخال القابس، تأكد من أن فولتية خط التيار المتردد (AC) الرئيسي لديك متوافقة مع موضع مفتاح اختيار الفولتية المتوفر خارج هذه المعدات وإذا اختلفت، فقم بإعادة ضبط مفتاح اختيار الفولتية، لمنع التلف أو الصدمة الكهربائية وخطر الحريق.

IMPORTANTE para a ligação à tensão da rede (CA)

ANTES DE LIGAR O APARELHO A UMA TOMADA DA REDE, verifique se a tensão da rede CA corresponde à posição do selector de voltagem localizado na parte externa deste equipamento. Caso não corresponda, reajuste o selector de voltagem a fim de evitar avarias ou riscos de incêndio e choque eléctrico.

JVC

VICTOR COMPANY OF JAPAN, LIMITED

Free Manuals Download Website

<http://myh66.com>

<http://usermanuals.us>

<http://www.somanuals.com>

<http://www.4manuals.cc>

<http://www.manual-lib.com>

<http://www.404manual.com>

<http://www.luxmanual.com>

<http://aubethermostatmanual.com>

Golf course search by state

<http://golfingnear.com>

Email search by domain

<http://emailbydomain.com>

Auto manuals search

<http://auto.somanuals.com>

TV manuals search

<http://tv.somanuals.com>