

# JVC



## AUDIO/VIDEO CONTROL RECEIVER

RECEPTOR DE CONTROL DE AUDIO/VÍDEO

RECEPTOR DE COMANDO AUDIO/VÍDEO

AV功率放大器 (带收音)

# RX-7001PGD

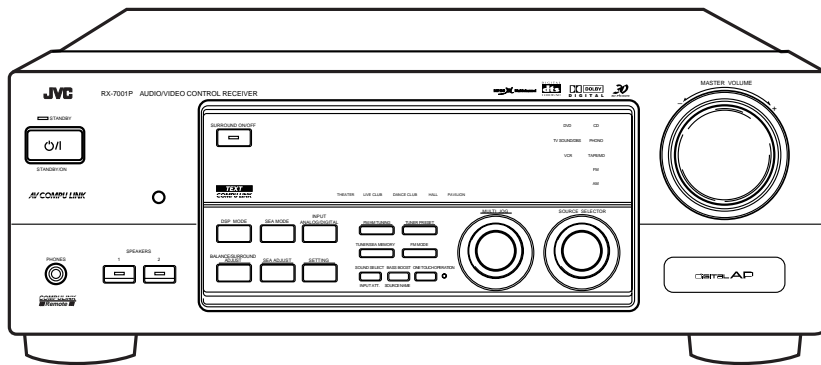
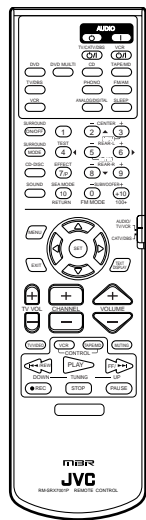

DIGITAL AP

TEXT  
COMPU LINK

AV COMPU LINK

COMPU LINK  
Remote

MPEG Multichannel

3D-PHONIC

DIGITAL  
DTS  
SURROUND

DOLBY  
DIGITAL

## INSTRUCTIONS

MANUAL DE INSTRUCCIONES  
INSTRUÇÕES  
使用说明书

### For Customer Use:

Enter below the Model No. and Serial No. which are located either on the rear, bottom or side of the cabinet. Retain this information for future reference.

Model No. \_\_\_\_\_

Serial No. \_\_\_\_\_

LVT0396-008A  
[U, US]

# Warnings, Cautions and Others / Avisos, precauciones y otras notas / Advertências, precauções e outras notas / 警告，注意及其他须知事项 تحذيرات، تنبيهات وأشياء أخرى

## CAUTION

To reduce the risk of electrical shocks, fire, etc.:

1. Do not remove screws, covers or cabinet.
2. Do not expose this appliance to rain or moisture.

## PRECAUCIÓN

Para reducir riesgos de choques eléctricos, incendio, etc.:

1. No extraiga los tornillos, los cubiertas ni la caja.
2. No exponga este aparato a la lluvia o a la humedad.

## ATENÇÃO

Para reduzir riscos de choques eléctricos, incêndio, etc.:

1. Não retire parafusos nem desmonte as tampas ou o gabinete.
2. Não exponha este aparelho à chuva nem à umidade.

## 警告

为了减低触电，火灾等危险：

1. 请勿擅自卸下螺丝钉，盖子或机壳。
2. 切勿让本机受雨淋或置潮湿环境中。

## تحذير

لتجنب خطر الحريق، الصدمات الكهربائية، الخ.:

١. لا تقم بفك البراغي، الاغطية أو الخزانات.
٢. لا تقم بتعرض هذا الجهاز للمطر أو للرطوبة.

### Caution — STANDBY/ON switch!

Disconnect the mains plug to shut the power off completely. The STANDBY/ON  switch in any position does not disconnect the mains line. The power can be remote controlled.

### Precaución — Interruptor STANDBY/ON /!

Desconectar el cable de alimentación para desactivar la alimentación totalmente. Cualquier que sea la posición de ajuste del interruptor STANDBY/ON , la alimentación no es cortada completamente. La alimentación puede ser controlada remotamente.

### Precaução — Interruptor STANDBY/ON /!

Desconectar o cabo de alimentação para desligar a alimentação por completo. Qualquer que seja a posição de ajuste do interruptor STANDBY/ON , a alimentação não é completamente cortada. A alimentação pode ser controlada remotamente.

### 注意— 开关！

无论  开关在任何位置，电源线的电源还是没有被切断，若要将电源完全关闭，应把电源插头拔离插座。电源开关可用遥控器控制。

### تحذير — الطاقة

انزع قابس الطاقة الكهربائية من اجل فصل الطاقة الكهربائية عن الجهاز كلياً. لا يفصل مفتاح الطاقة الكهربائية عندما يكون باي وضع  الطاقة الكهربائية عن الجهاز. يمكن التحكم عن بعد بالطاقة الكهربائية.

### Caution: Proper Ventilation

To avoid risk of electric shock and fire and to protect from damage. Locate the apparatus as follows:

- Front: No obstructions open spacing.  
Sides: No obstructions in 10 cm from the sides.  
Top: No obstructions in 10 cm from the top.  
Back: No obstructions in 15 cm from the back  
Bottom: No obstructions, place on the level surface.  
In addition, maintain the best possible air circulation as illustrated.

### Precaución: Ventilación Adecuada

Para evitar el riesgo de choque eléctrico e incendio y para proteger el aparato contra daños.

Ubique el aparato de la siguiente manera:

- Frente: Espacio abierto sin obstrucciones  
Lados: 10 cm sin obstrucciones a los lados  
Parte superior: 10 cm sin obstrucciones en la parte superior  
Parte trasera: 15 cm sin obstrucciones en la parte trasera  
Fondo: Sin obstrucciones, colóquelo sobre una superficie nivelada

Además, mantenga la mejor circulación de aire posible como se ilustra.

### Precaução: ventilação apropriada

Para prevenir o risco de choque elétrico ou incêndio e para proteger o aparelho contra danos.

Localize-o da seguinte maneira:

- Frente: Espaço aberto, sem obstruções  
Lados: Espaço de 10 cm sem obstruções nos lados  
Topo: Espaço de 10 cm sem obstruções acima  
Atrás: Espaço de 15 cm sem obstruções atrás  
Parte inferior: Sem obstruções. Coloque o aparelho em superfície nivelada.

Mantenha, além disso, a maior circulação de ar possível, como indica a ilustração.

### 注意：正确的通风方法

为了防止触电、火灾以及避免损坏，按如下要求放置机器：

- 前面：留下空间不要放置障碍物。  
侧面：侧面的 10cm 之内不要放置障碍物。  
上面：上面的 10cm 之内不要放置障碍物。  
背面：背面的 15cm 之内不要放置障碍物。  
底部：不要放置障碍物、水平放置。

此外，如图所示，尽可能保持最佳的空气循环。

تنبيه: حول التهوية الصحيحة لتفادي وقوع الصدمة الكهربائية والحريق، ولحماية الأجهزة من التلف قم بتحديد مواقع تركيب الأجهزة كالتالي:

الامام: مساحة فارغة بدون عوائق  
الجوانب: عدم وجود أية عوائق بطول ١٠ سم من الجوانب  
السطح العلوي: عدم وجود أية عوائق بطول ١٠ سم من السطح العلوي  
الخلف: عدم وجود أية عوائق بطول ١٥ سم من اللوحة الخلفية  
القاع: عدم وجود أية عوائق، يجب وضع الأجهزة على السطح المستوي.  
بالإضافة الى ذلك، احتفظ بأفضل توزيع للهواء كما هو مبين في الرسم.

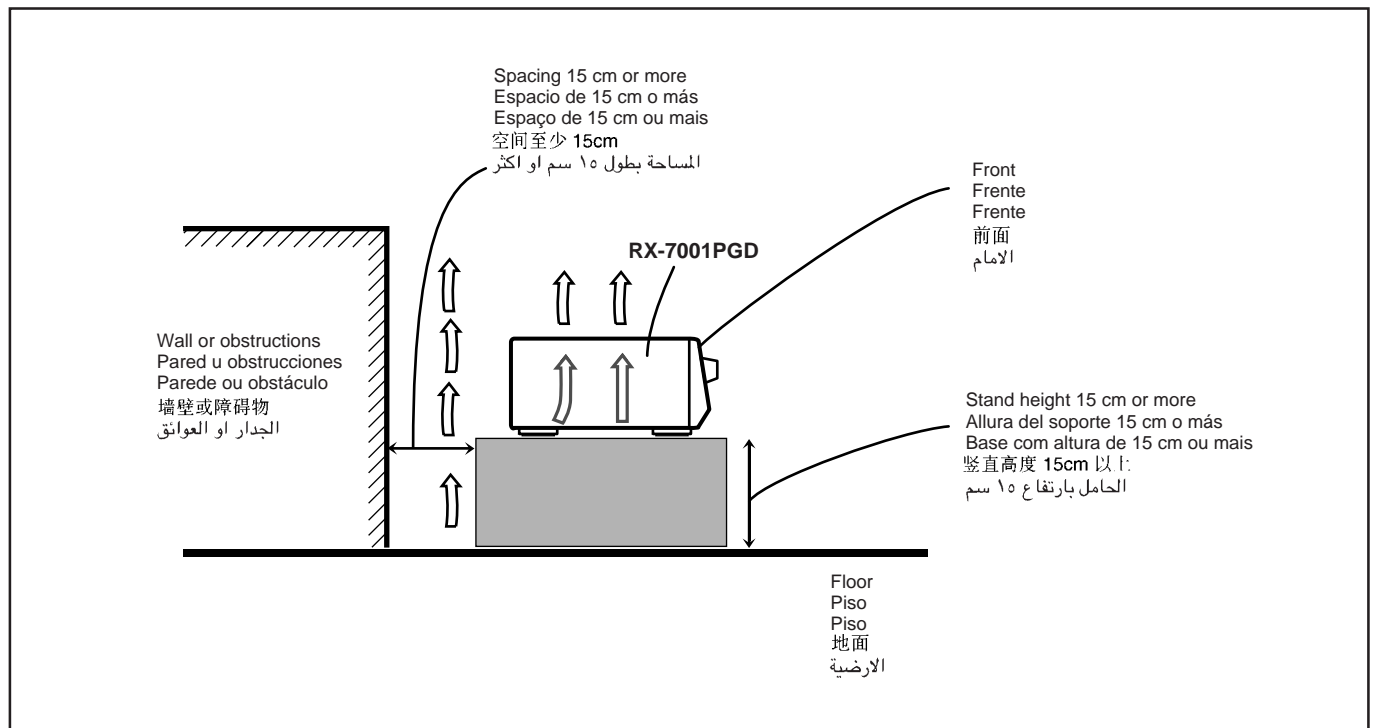

# Table of Contents

<b>Parts Identification .....</b>	<b>2</b>	<b>Using the DSP Modes .....</b>	<b>21</b>
<b>Getting Started .....</b>	<b>3</b>	Available DSP Modes According to the Speaker Arrangement ..	23
Before Installation .....	3	Adjusting the 3D-PHONIC Modes .....	24
Checking the Supplied Accessories .....	3	Adjusting the DAP Modes .....	24
Setting the Voltage Selector Switch .....	3	Adjusting the Surround Modes .....	25
Connecting the FM and AM Antennas .....	3	Activating the DSP Modes .....	27
Connecting the Speakers .....	4	<b>Using the DVD MULTI Playback Mode .....</b>	<b>29</b>
Connecting Audio/Video Components .....	5	Activating the DVD MULTI Playback Mode .....	29
Connecting the Power Cord .....	9	<b>Using the On-Screen Menus .....</b>	<b>30</b>
Putting Batteries in the Remote Control .....	9	Selecting the Source to Play .....	30
<b>Basic Operations .....</b>	<b>10</b>	Selecting Different Sources for Picture and Sound .....	30
Turning the Power On and Off (Standby) .....	10	Activating the DSP Modes .....	30
Selecting the Source to Play .....	10	Selecting the Analog or Digital Input Mode .....	30
Adjusting the Volume .....	11	Adjusting the Front Speaker Output Balance .....	31
Selecting the Front Speakers .....	11	Reinforcing the Bass .....	31
Muting the Sound .....	12	Attenuating the Input Signal .....	31
Reinforcing the Bass .....	12	Adjusting the Subwoofer Output Level .....	31
Attenuating the Input Signal .....	12	Adjusting the DSP Modes .....	31
Adjusting the Subwoofer Output Level .....	12	Adjusting the DVD MULTI Playback Mode .....	32
<b>Basic Settings .....</b>	<b>13</b>	Selecting Your Favorite SEA Mode .....	32
Recording a Source .....	13	Creating Your Own SEA Mode .....	32
Adjusting the Front Speaker Output Balance .....	13	Setting the Basic Setting Items .....	33
Changing the Source Name .....	13	Operating the Tuner .....	33
Setting the Subwoofer Information .....	14	Storing the Preset Stations .....	34
Setting the Speakers for the DSP Modes .....	14	Assigning Names to Preset Stations .....	34
Digital Input (DIGITAL IN) Terminal Setting .....	16	<b>COMPU LINK Remote Control System .....</b>	<b>35</b>
Selecting the Analog or Digital Input Mode .....	16	<b>TEXT COMPU LINK Remote Control System ..</b>	<b>36</b>
Showing the Text Information on the Display .....	17	Showing the Disc Information on the TV Screen .....	37
Setting the AM Tuner Interval Spacing .....	17	Searching for a Disc (Only for the CD player) .....	38
Storing the Basic Settings and Adjustments — One Touch		Entering the Disc Information .....	39
Operation .....	17	<b>AV COMPU LINK Remote Control System ....</b>	<b>41</b>
Using the Sleep Timer .....	17	<b>Operating JVC's Audio/Video Components ...</b>	<b>43</b>
<b>Receiving Radio Broadcasts .....</b>	<b>18</b>	Operating Audio Components .....	43
Tuning in Stations Manually .....	18	Operating Video Components .....	45
Using Preset Tuning .....	18	<b>Operating Other Manufacturers' Video</b>	
Selecting the FM Reception Mode .....	19	<b>Equipment .....</b>	<b>46</b>
Assigning Names to Preset Stations .....	19	<b>Troubleshooting .....</b>	<b>52</b>
<b>Using the SEA Modes .....</b>	<b>20</b>	<b>Specifications .....</b>	<b>53</b>
Selecting Your Favorite SEA Mode .....	20		
Creating Your Own SEA Mode .....	20		

# Parts Identification

Become familiar with the buttons and controls on the receiver before use.  
Refer to the pages in parentheses for details.

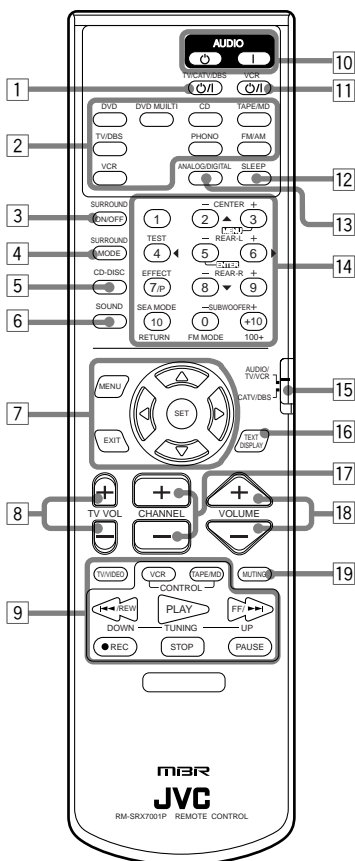
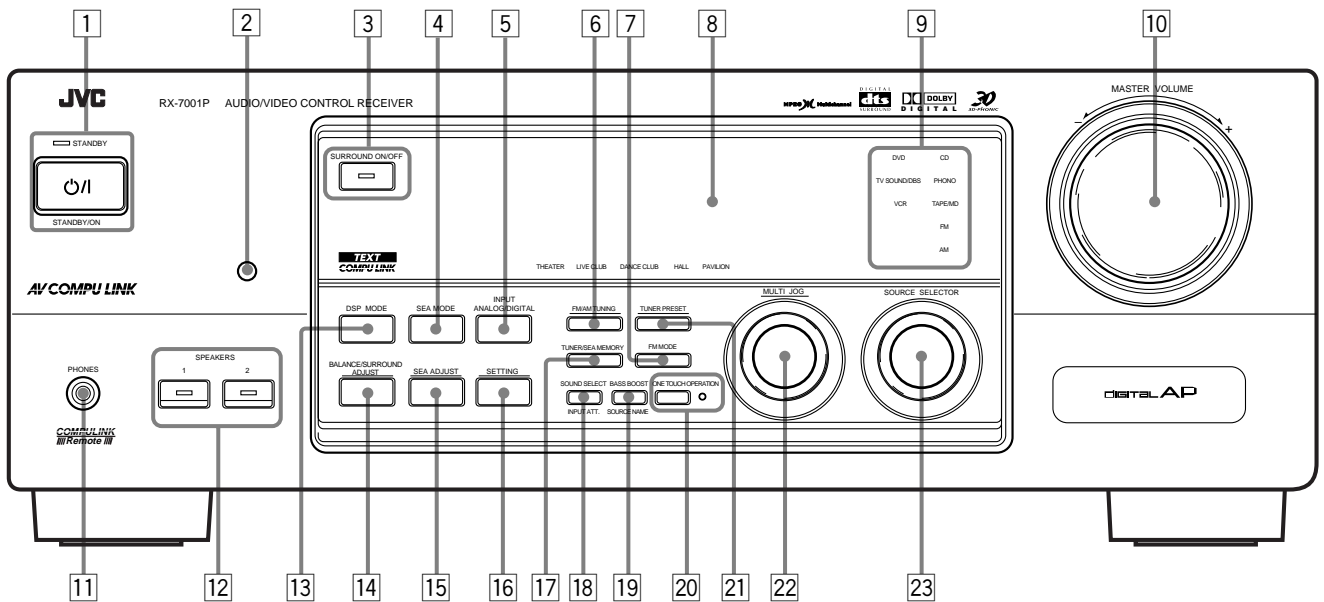

## Remote Control

- 1 TV/CATV/DBS  $\odot$ /I button (45, 46)
- 2 Source selecting buttons (10)  
DVD, DVD MULTI, CD, TAPE/MD, TV/DBS, PHONO, FM/AM, VCR
- 3 SURROUND ON/OFF button (25, 27)
- 4 SURROUND MODE button (25, 26)
- 5 CD-DISC button (44)
- 6 SOUND button (20, 24, 29)
- 7 On-screen operation buttons (30, 37)  
MENU, SET, EXIT,  $\Delta$ ,  $\nabla$ ,  $\triangleleft$ ,  $\triangleright$
- 8 TV VOL +/- buttons (45, 46)
- 9 Operating buttons for audio/video components (43 - 47)
- 10 AUDIO buttons  $\odot$ , | (10)
- 11 VCR  $\odot$ /I button (45, 47)
- 12 SLEEP button (17)
- 13 ANALOG/DIGITAL button (16)
- 14
  - 10 keys for selecting preset channels (19)
  - 10 keys for adjusting sound (20, 24 - 27, 29)
  - 10 keys for operating audio/video components (43 - 47)
- 15 Remote control mode selector (10, 43, 46)
- 16 TEXT DISPLAY button (37)
- 17 CHANNEL +/- buttons (45 - 47)
- 18 VOLUME +/- buttons (11)
- 19 MUTING button (12)

## Front Panel

- 1 STANDBY/ON  $\odot$ /I button and STANDBY lamp (10)
- 2 Remote sensor (9)
- 3 SURROUND ON/OFF button and lamp (26, 27)
- 4 SEA MODE button (20)
- 5 INPUT ANALOG/DIGITAL button (16)
- 6 FM/AM TUNING button (18)\*
- 7 FM MODE button (19)
- 8 Display (10)
- 9 Source lamps (10)
- 10 MASTER VOLUME control (11)
- 11 PHONES jack (12)
- 12 SPEAKERS 1/2 buttons and lamps (11)
- 13 DSP MODE button (24)
- 14 BALANCE/SURROUND ADJUST button (12, 13, 24)\*
- 15 SEA ADJUST button (20)\*
- 16 SETTING button (14 - 17)\*
- 17 TUNER/SEA MEMORY button (18 - 20)
- 18 SOUND SELECT/INPUT ATT. button (11, 12)
- 19 BASS BOOST/SOURCE NAME button (12, 13)
- 20 ONE TOUCH OPERATION button and lamp (17)
- 21 TUNER PRESET button (19)\*
- 22 MULTI JOG control  
What this control actually does depends on which function you are trying to adjust. Before using this control, select the function by pressing one of the buttons marked with \*.
- 23 SOURCE SELECTOR control (10)

# Getting Started

This section explains how to connect audio/video components and speakers to the receiver, and how to connect the power supply.

## Before Installation

### General

- Be sure your hands are dry.
- Turn the power off to all components.
- Read the manuals supplied with the components you are going to connect.

### Locations

- Install the receiver in a location that is level and protected from moisture.
- The temperature around the receiver must be between  $-5^{\circ}\text{C}$  and  $35^{\circ}\text{C}$  ( $23^{\circ}\text{F}$  and  $95^{\circ}\text{F}$ ).
- Make sure there is good ventilation around the receiver. Poor ventilation could cause overheating and damage the receiver.

### Handling the receiver

- Do not insert any metal object into the receiver.
- Do not disassemble the receiver or remove screws, covers, or cabinet.
- Do not expose the receiver to rain or moisture.

## Checking the Supplied Accessories

Check to be sure you have all of the following items, which are supplied with the receiver.

The number in the parentheses indicates quantity of the pieces supplied.

- Remote Control (1)
- Batteries (2)
- AM Loop Antenna (1)
- FM Antenna (1)
- AC Plug Adaptor (1)

If anything is missing, contact your dealer immediately.

## Setting the Voltage Selector Switch

Before connections, always do the following first if necessary.

Set the correct voltage for your area with the voltage selector switch on the rear panel. Use a screw driver to rotate the switch so the number the arrow is pointing at is the same as the voltage where you are plugging in the receiver.

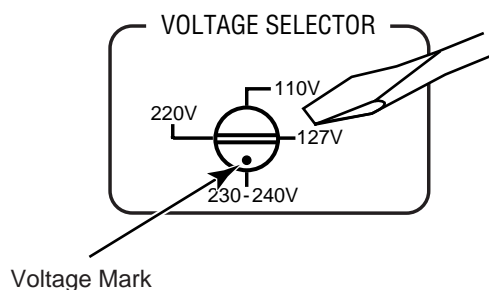

## Connecting the FM and AM Antennas

### FM Antenna Connections

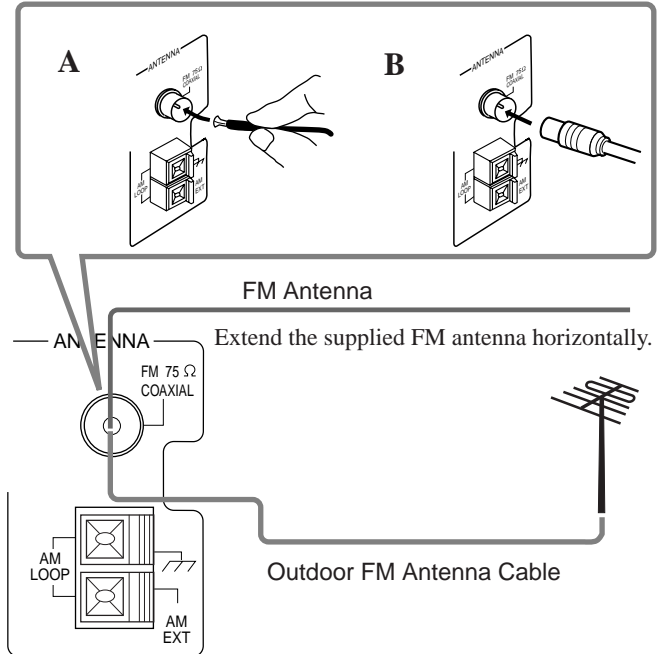

#### A. Using the Supplied FM Antenna

The FM antenna provided can be connected to the FM 75  $\Omega$  COAXIAL terminal as temporary measure.

#### B. Using the Standard Type Connector (Not Supplied)

A standard type connector should be connected to the FM 75  $\Omega$  COAXIAL terminal.

#### Note:

If reception is poor, connect the outdoor antenna.

Before attaching a 75  $\Omega$  coaxial cable (the kind with a round wire going to an outdoor antenna), disconnect the supplied FM antenna.

## AM Antenna Connections

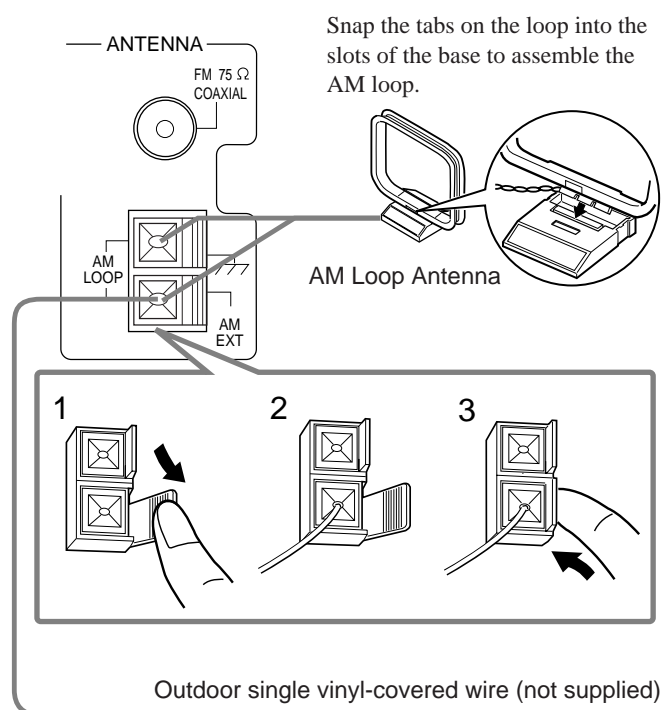

Turn the loop until you have the best reception.

### Notes:

- Make sure the antenna conductors do not touch any other terminals, connecting cords and power cord. This could cause poor reception.
- If reception is poor, connect an outdoor single vinyl-covered wire to the AM EXT terminal. (Keep the AM loop antenna connected.)

## Connecting the Speakers

You can connect the following speakers:

- Two pairs of front speakers to produce normal stereo sound.
- One pair of rear speakers to enjoy the surround effect.
- One center speaker to produce more effective surround effect (to emphasize human voices).
- One subwoofer to enhance the bass.

### IMPORTANT:

After connecting the speakers listed above, set the speaker setting information properly to obtain the best possible DSP effect. For details, see page 14.

For each speaker (except for a subwoofer), connect the (-) and (+) terminals on the rear panel to the (-) and (+) terminals marked on the speakers. For connecting a subwoofer, see page 5.

### CAUTION:

Use speakers with the SPEAKER IMPEDANCE indicated by the speaker terminals.

## Basic connecting procedure

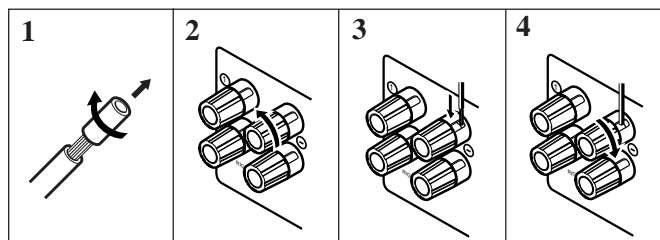

- 1 Cut, twist and remove the insulation at the end of each speaker signal cable (not supplied).
- 2 Turn the knob counterclockwise.
- 3 Insert the speaker signal cable.
- 4 Turn the knob clockwise.

## Connecting the front speakers

You can connect two pairs of front speakers (one pair to the FRONT SPEAKERS ① terminals, and another pair to the FRONT SPEAKERS ② terminals).

Right speaker — FRONT SPEAKERS ① — Left speaker

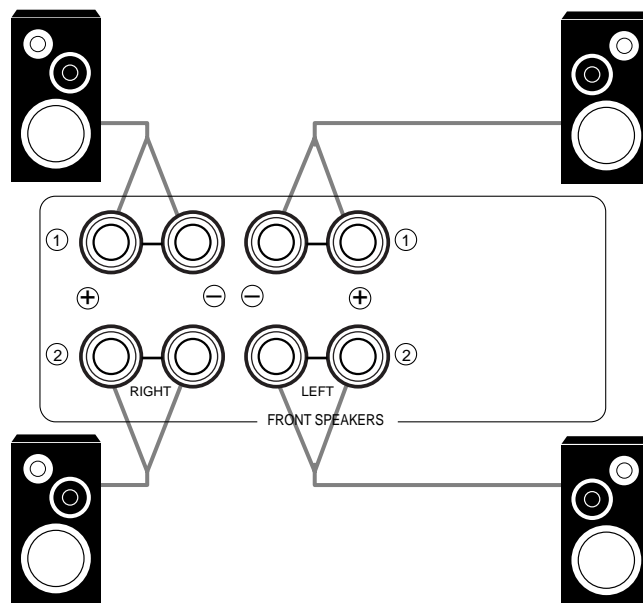

Right speaker — FRONT SPEAKERS ② — Left speaker



### About the speaker impedance

The required speaker impedance of the front speakers does differ depending on whether both the FRONT SPEAKERS ① and FRONT SPEAKERS ② terminals are used or only one of them is used.

**CASE 1** When you connect only one set of front speakers

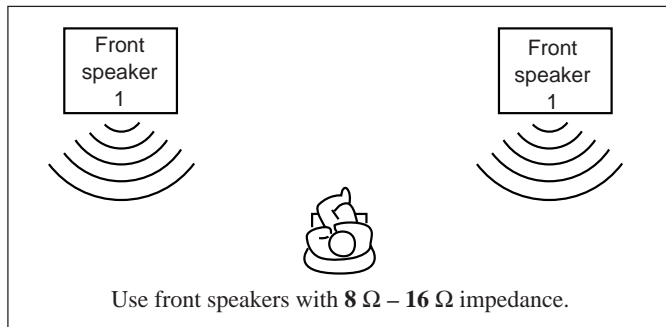

**CASE 2** When you connect two sets of front speakers

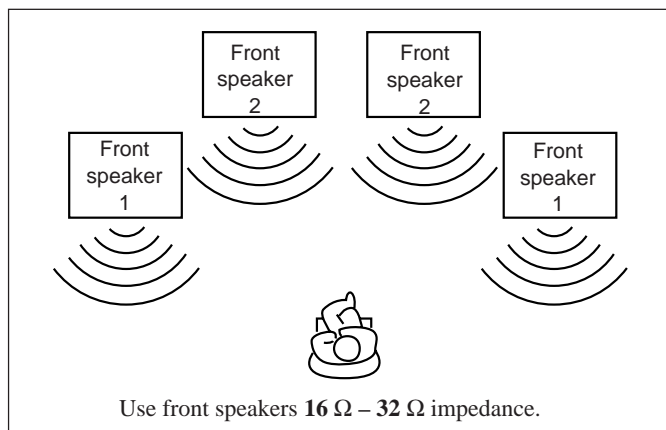

### Connecting the rear and center speakers

Connect rear speakers to the REAR SPEAKERS terminals and a center speaker to the CENTER SPEAKER terminals.

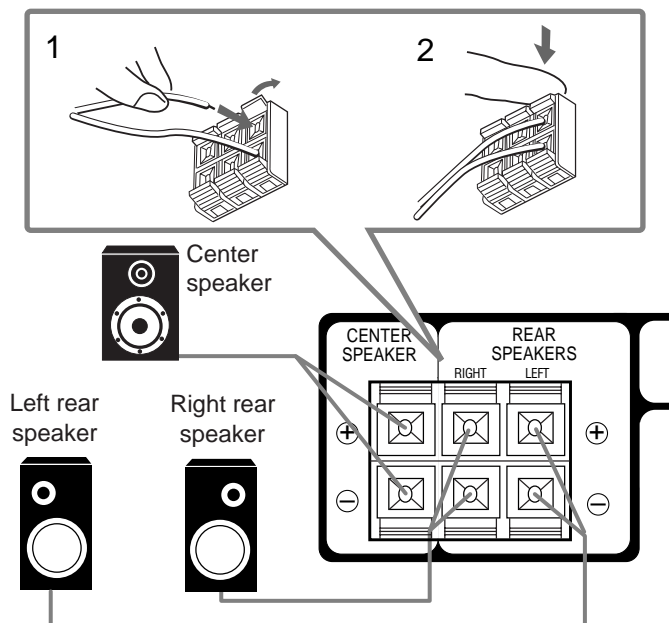

### Connecting the subwoofer speaker

You can enhance the bass by connecting a subwoofer. Connect the input jack of a powered subwoofer to the SUBWOOFER OUT jack on the rear panel, using a cable with RCA pin plugs (not supplied).

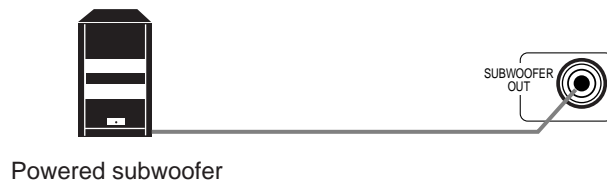

### Connecting Audio/Video Components

You can connect the following audio/video components to this receiver. Refer also to the manuals supplied with your components.

Audio Components	Video Components
• Turntable	• DVD player*
• CD player*	• TV*
• Cassette deck or MD recorder*	• DBS tuner*
	• VCR

\* You can connect these components using the methods described in "Analog connections" (below) or in "Digital connections" (see page 8).

#### Analog connections

##### Audio component connections

Use the cables with RCA pin plugs (not supplied). Connect the white plug to the audio left jack, and the red plug to the audio right jack.

#### CAUTION:

If you connect a sound-enhancing device such as a graphic equalizer between the source components and this receiver, the sound output through this receiver may be distorted.

#### Turntable

If an earth cable is provided for your turntable, connect the cable to the screw marked (⊕) on the rear panel.

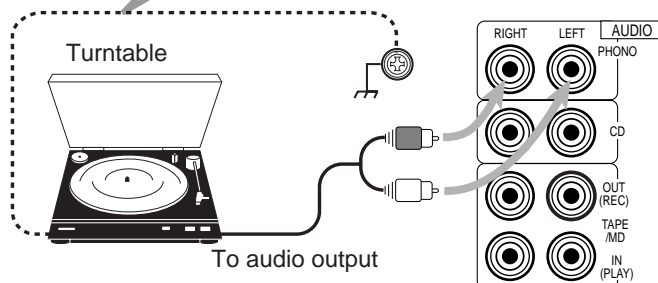

#### Note:

Any turntables incorporating a small-output cartridge such as an MC (moving-coil) type must be connected to this receiver through a commercial head amplifier or step-up transformer. Direct connection may result in insufficient volume.



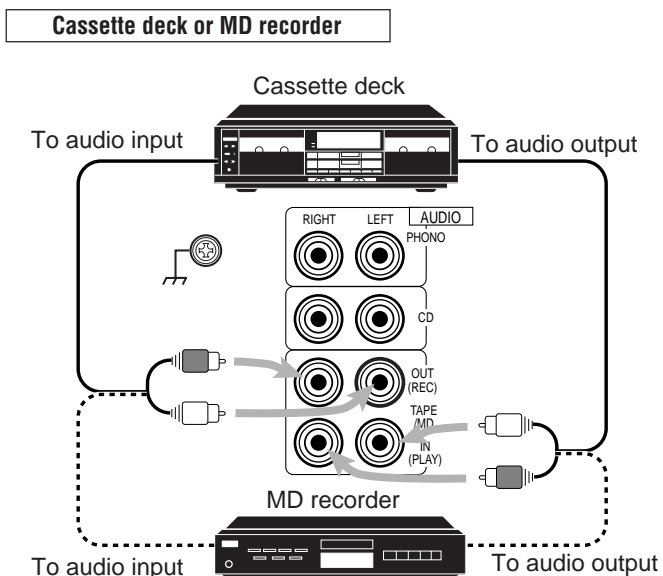
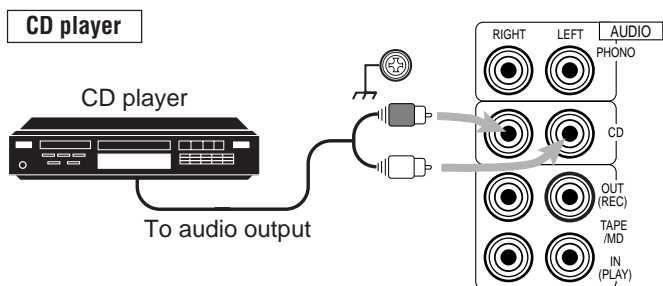

**Note:**

You can connect either a cassette deck or an MD recorder to the TAPE/MD jacks. When connecting an MD recorder to the TAPE/MD jacks, change the source name, which will be shown on the display when selected as the source, to "MD." See page 13 for details.

**If your audio components have a COMPU LINK-3 or TEXT COMPU LINK jack**

- See also page 35 for detailed information about the connection and the COMPU LINK-3 remote control system.
- See also page 36 for detailed information about the connection and the TEXT COMPU LINK remote control system.

**Video component connections**

Use the cables with RCA pin plugs (not supplied). Connect the white plug to the audio left jack, the red plug to the audio right jack, and the yellow plug to the video jack. If your video components have S-video (Y/C-separation) terminals, connect them using S-video cables (not supplied). Connecting these video components through the S-video input/output terminals will give you better picture playback (or recording) quality.

**IMPORTANT:**

This receiver is equipped with both the composite video and S-video input/output terminals for connecting video components. You do not have to connect both the composite video and S-video terminals.

However, **remember that the video signals from the composite video input terminals are output only through the composite video output terminals, while the ones from the S-video input terminals are output only through the S-video output terminals.** Therefore, if a recording video component and a playing video component are connected to the receiver through the different video terminals, you cannot record the picture from the playing component on the recording component. In addition, if the TV and a playing video component are connected to the receiver through the different video terminals, you cannot view the playback picture from the playing component on the TV.

**VCR**

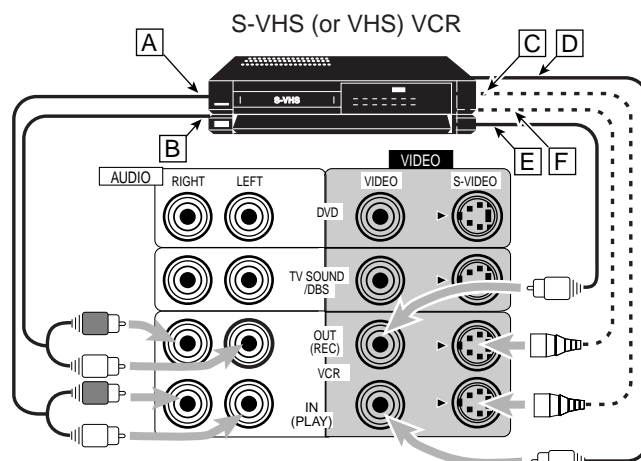

- [A] To left/right channel audio output
- [B] To left/right channel audio input
- [C] To S-video output
- [D] To composite video output
- [E] To composite video input
- [F] To S-video input

**TV and/or DBS tuner**

When connecting the TV, DO NOT connect the TV's video output to these video input terminals.

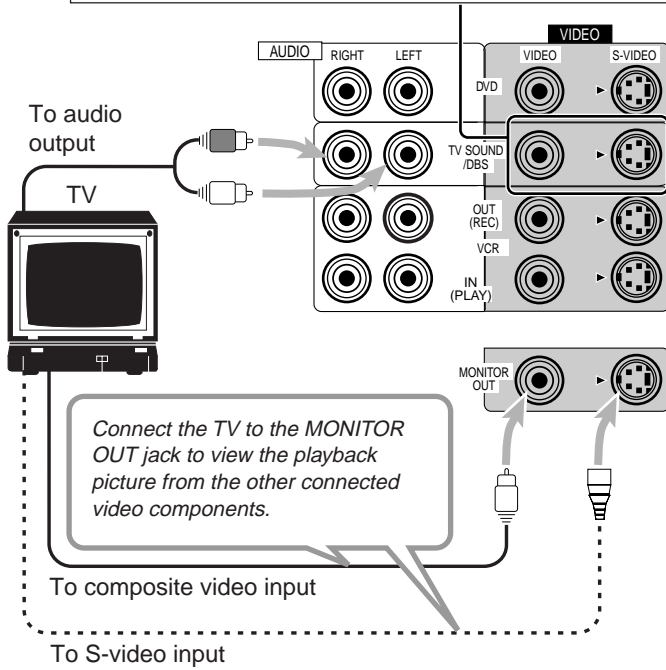

**Note:**

Use a TV of the PAL- or multi-color system.

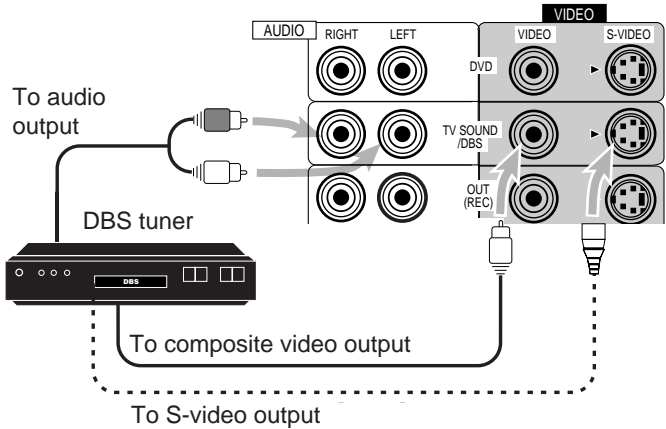

**Note:**

When connecting the DBS tuner to the TV SOUND/DBS jacks, change the source name, which will be shown on the display when selected as the source, to "DBS." See page 13 for details.

**DVD player**

- When you connect the DVD player with stereo output jacks:

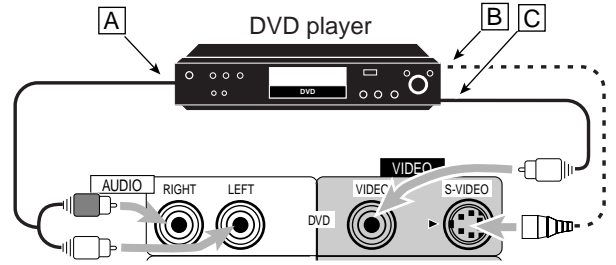

- A To front left/right channel audio output (or to audio mixed output if necessary)
- B To S-video output
- C To composite video output

- When you connect the DVD player with its analog discrete output (5.1 CH reproduction) jacks:

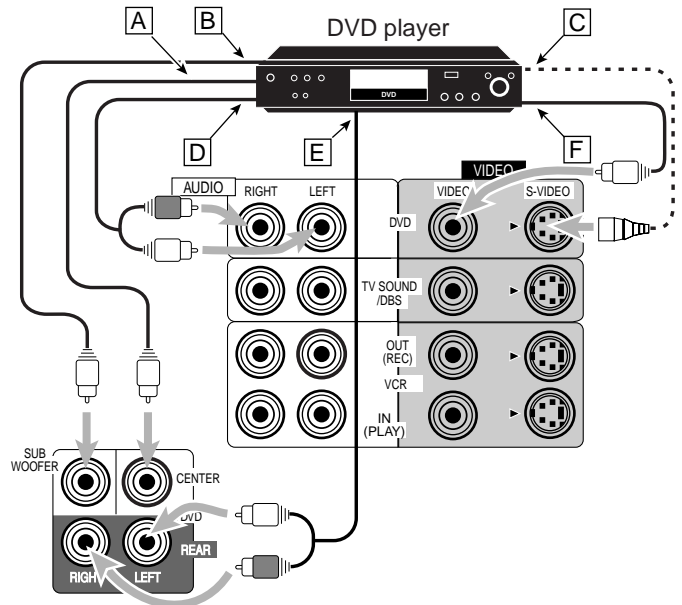

- A To center channel audio output
- B To subwoofer audio output
- C To S-video output
- D To front left/right channel audio output
- E To rear left/right channel audio output
- F To composite video output

## Digital connections

This receiver is equipped with three DIGITAL IN terminals — one digital coaxial terminal and two digital optical terminals, and one DIGITAL OUT terminal.

You can connect any digital equipment such as —

- DBS tuner,
- Digital TV broadcast tuner,
- DVD player,
- CD player,
- and MD recorder.

### IMPORTANT:

- When connecting the DVD player, digital TV broadcast tuner or DBS tuner using the digital terminals, you also need to connect it to the video jack (either composite video terminal or S-video terminal) on the rear. Without connecting it to the video jack, you can view no playback picture.
- After connecting the components using the DIGITAL IN terminals, set the following correctly if necessary.
  - Set the digital input (DIGITAL IN) terminal setting correctly. For details, see “Digital Input (DIGITAL IN) Terminal Setting” on page 16.
  - Select the digital input mode correctly. For details, see “Selecting the Analog or Digital Input Mode” on page 16.

### Digital input terminals

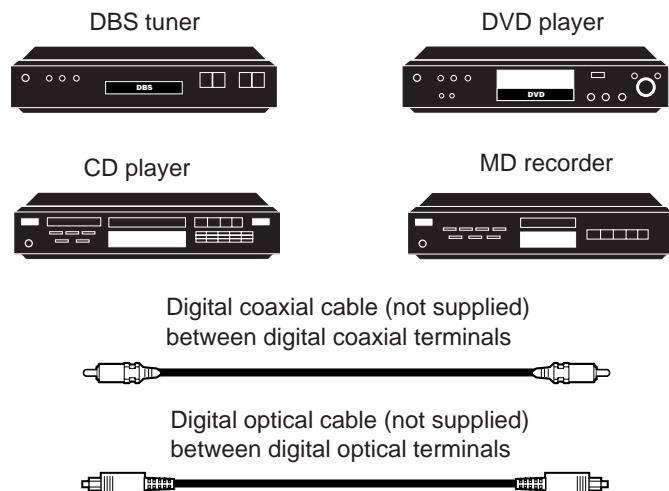

### Notes:

- When shipped from the factory, the DIGITAL IN terminals have been set for use with the following components.
  - DIGITAL 1 (coaxial): For DVD player
  - DIGITAL 2 (optical): For CD player
  - DIGITAL 3 (optical): For digital TV broadcast tuner
- When you want to operate the CD player or MD recorder using the COMPU LINK remote control system, connect the target component also as described in “Analog connections” (see pages 5 and 6).
- When you want to operate the DVD player using the AV COMPU LINK remote control system, connect the DVD player also as described in “Analog connections” (see page 7).

### Digital output terminal

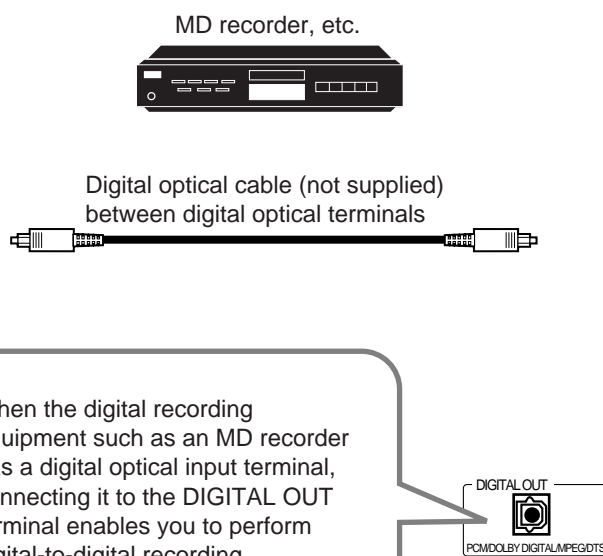

When the component has a digital coaxial output terminal, connect it to the DIGITAL 1 (DVD) terminal, using the digital coaxial cable (not supplied).

When the component has a digital optical output terminal, connect it to the DIGITAL 2 (CD), or DIGITAL 3 (TV) terminal, using the digital optical cable (not supplied).

Before connecting a digital optical cable, unplug the protective plug.

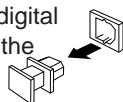

## Connecting the Power Cord

Before plugging the receiver into an AC outlet, make sure that all connections have been made.

### Plug the power cord into an AC outlet.

Keep the power cord away from the connecting cables and the antenna. The power cord may cause noise or screen interference. We recommend that you use a coaxial cable to connect the antenna, since it is well-shielded against interference.

### Notes:

- The preset settings such as preset channels and sound adjustment may be erased in a few days in the following cases:
  - When you unplug the power cord.
  - When a power failure occurs.
- If the wall outlet does not match the AC plug, use the supplied AC plug adaptor.

### CAUTIONS:

- Do not plug in before setting the voltage selector switch on the rear of the unit and all connection procedures are complete.
- Do not touch the power cord with wet hands.
- Do not pull on the power cord to unplug the cord. When unplugging the cord, always grasp the plug so as not to damage the cord.

## Putting Batteries in the Remote Control

Before using the remote control, put two supplied batteries first. When using the remote control, aim the remote control directly at the remote sensor on the receiver.

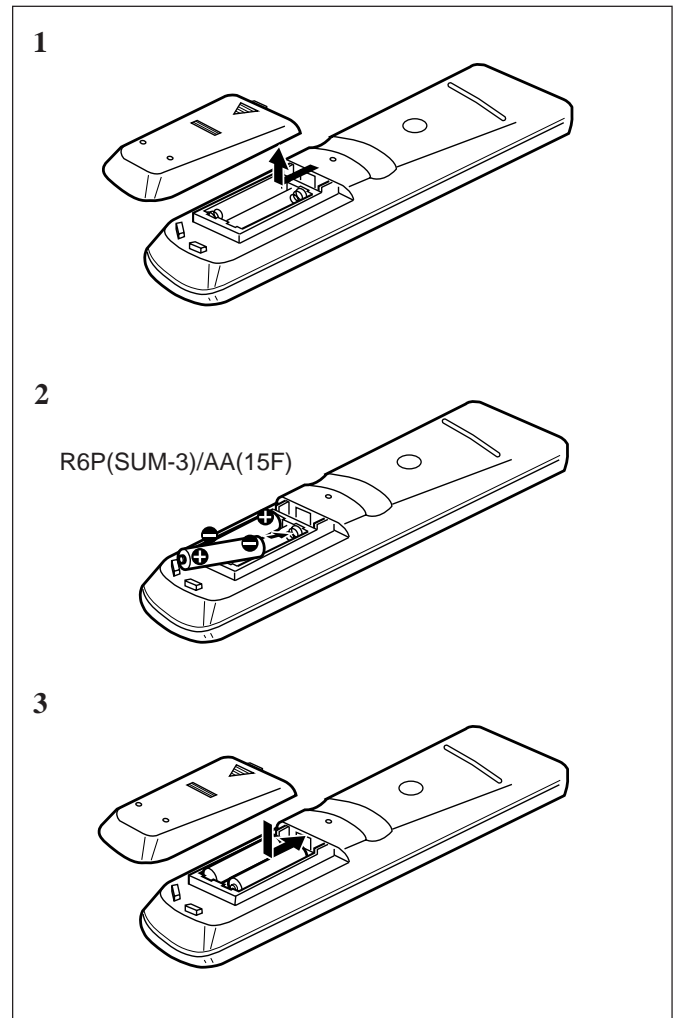

1. On the back of the remote control, remove the battery cover.
2. Insert batteries. Make sure to match the polarity: (+) to (+).
3. Replace the cover.

If the range or effectiveness of the remote control decreases, replace the batteries. Use two R6P(SUM-3)/AA(15F) type dry-cell batteries.

### CAUTION:

Follow these precautions to avoid leaking or cracking cells:

- Place batteries in the remote control so they match the polarity: (+) to (+).
- Use the correct type of batteries. Batteries that look similar may differ in voltage.
- Always replace both batteries at the same time.
- Do not expose batteries to heat or flame.

# Basic Operations

The following operations are commonly used when you play any sound source.

## IMPORTANT:

When using the remote control, check to see if its remote control mode selector is set to the correct position:

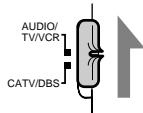

To operate this receiver, set it to "AUDIO/TV/VCR."

## From the remote control:

Press one of the source selecting buttons.

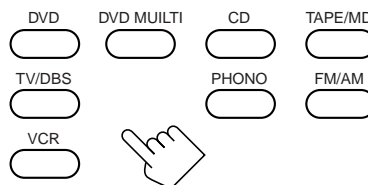

## Turning the Power On and Off (Standby)

### On the front panel:

To turn on the power, press STANDBY/ON . The STANDBY lamp goes off. The name of the current source (or station frequency) appears on the display.

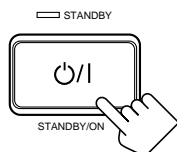

Current source name appears

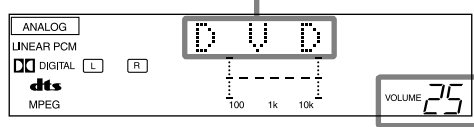

Current volume level is shown here

To turn off the power (into standby mode), press STANDBY/ON again.

The STANDBY lamp lights up. A small amount of power is consumed in standby mode. To turn the power off completely, unplug the AC power cord.

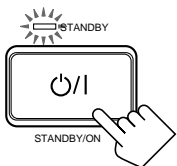

### From the remote control:

To turn on the power, press AUDIO .

The STANDBY lamp goes off. The name of the current source (or station frequency) appears on the display.

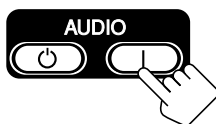

To turn off the power (into standby mode), press AUDIO .

The STANDBY lamp lights up.



## Selecting the Source to Play

### On the front panel:

Turn SOURCE SELECTOR until the source name you want appears on the display.

- As you turn the selector, the source changes as follows:

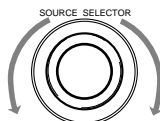

CD ⇄ PHONO ⇄ TAPE (or MD) ⇄ FM ⇄ AM ⇄ DVD ⇄ DVD MULTI ⇄ TV SOUND (or DBS) ⇄ VCR ⇄ (back to the beginning)

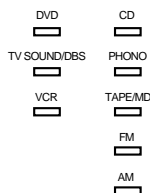

The selected source lamp also lights up.

- The DVD lamp lights up both for "DVD" and "DVD MULTI."

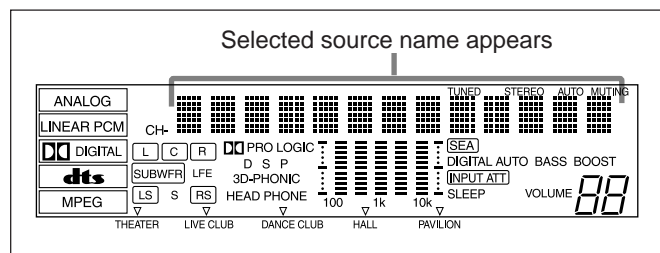

- DVD** Select the DVD player.
- DVD MULTI** Select the DVD player for viewing the digital video disc using the analog discrete output mode (5.1CH reproduction) on the DVD player. To enjoy the DVD MULTI playback, see page 29.
- CD\*** Select the CD player.
- TAPE/MD\*** Select the cassette deck (or the MD recorder).
- TV/DBS** Select TV sounds (or the DBS tuner).
- PHONO\*** Select the turntable.
- FM/AM\*** Select an FM or AM broadcast.
  - Each time you press the button, the band alternates between FM and AM.
- VCR** Select the video component connected to the VCR jacks.

### Notes:

- When connecting an MD recorder (to the TAPE/MD jacks), and a DBS tuner (to the TV SOUND/DBS jacks), change the source name shown on the display. For details, see page 13.
- When you press one of the source selecting buttons on the remote control marked above with an asterisk (\*), the receiver automatically turns on.

### Signal and speaker indicators on the display

- The signal indicators light up to indicate the incoming channel signals.
  - Only the indicators for the incoming signals light up.
- The frame of the signal indicator (except for "LFE" and "S") lights up if the corresponding speaker is set to "LARGE" or "SMALL" (for subwoofer, "YES").
  - The frames of "L" and "R" indicators always light up.

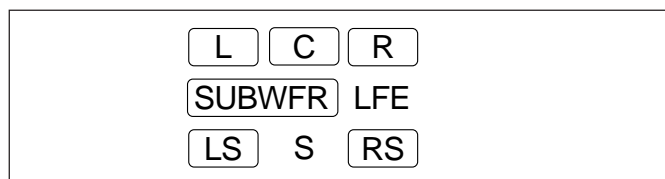

- L: **When digital input is selected:** Lights up when the left channel signal comes in.  
**When analog input is selected:** Always lights up.
- R: **When digital input is selected:** Lights up when the right channel signal comes in.  
**When analog input is selected:** Always lights up.
- C: Lights up when the center channel signal comes in.
- LS: Lights up when the left rear channel signal comes in.
- RS: Lights up when the right rear channel signal comes in.
- S: Lights up when the monaural rear channel signal comes in.
- LFE: Lights up when the LFE channel signal comes in.

#### Notes:

- When "SUBWOOFER" is set to "YES," **SUBWFR** lights up.
- When you select "DVD MULTI," all the signal indicators except "S" light up.

### Selecting different sources for picture and sound

You can watch picture from a video component while listening to sound from another component.

#### On the front panel:

- Press **SOUND SELECT (INPUT ATT.)** briefly while viewing the picture from a video component such as the VCR or DVD player, etc.

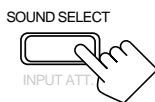

"SOUND SELECT" appears on the display.

- Turn **SOURCE SELECTOR** to select the sound (except the TV sound), while the indication of the above step is still on the display.

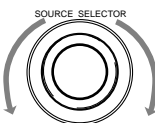

#### From the remote control:

Press one of the audio source selecting buttons (CD, TAPE/MD, PHONO, FM/AM, TV/DBS\*), while viewing the picture from a video component such as the VCR or DVD player, etc.

#### Notes:

- Once you have selected a video source, pictures of the selected source are sent to the TV until you select another video source.
- \* The TV/DBS button only works for selecting "DBS" as the source but not for selecting "TV SOUND." When you use the DBS tuner, change the source name correctly (see page 13).

### Adjusting the Volume

#### On the front panel:

To increase the volume, turn MASTER VOLUME clockwise.

To decrease the volume, turn it counterclockwise.

- When you turn MASTER VOLUME rapidly, the volume level also changes rapidly.
- When you turn MASTER VOLUME slowly, the volume level also changes slowly.

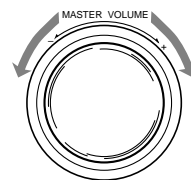

#### From the remote control:

To increase the volume, press VOLUME +.

To decrease the volume, press VOLUME -.

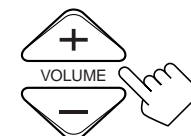

#### CAUTION:

Always set the volume to the minimum before starting any source. If the volume is set at its high level, the sudden blast of sound energy can permanently damage your hearing and/or ruin your speakers.

#### Note:

The volume level can be adjusted within the range of "0" (minimum) to "90" (maximum).

### Selecting the Front Speakers

#### On the front panel ONLY:

When you have connected two pairs of the front speakers, you can select which to use.

Press **SPEAKERS 1** or **SPEAKERS 2** to select the speaker to use.

- Each time you press the button, the lamp on the respective button turns on and off. When the lamp on either button lights up, the respective speakers are activated.

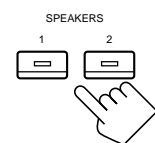

#### Note:

If you use any of the DSP modes other than the 3D-PHONIC modes with both front speakers activated, the speakers connected to the FRONT SPEAKERS ② terminals are deactivated.



## Listening only with headphones

You can listen with the headphones without deactivating both pairs of speakers; however, if you want to use the HEADPHONE mode (see below), you must turn off both pairs of speakers.

1. Connect a pair of headphones to the PHONES jack on the front panel.
2. Press SPEAKERS 1 and/or 2 so that no lamps on the buttons are turned on.

This cancels the surround mode or DSP mode currently selected, and activates the HEADPHONE mode (see below).

- The HEAD PHONE indicator lights up on the display.

### HEADPHONE mode:

This mode can reproduce the LFE channel signals, mixing them with the front channel signals. So you will not miss the subwoofer sounds even if you listen to a source using the headphones.

### Notes:

- While in the HEADPHONE mode, you cannot use any other DSP modes (see page 21.)
- Activating the speaker cancels the headphones mode and turns on the DSP mode previously selected.

### CAUTION:

Be sure to turn down the volume before connecting or putting on headphones, as high volume can damage both the headphones and your hearing.

## Muting the Sound

### From the remote control ONLY:

Press **MUTING** to mute the sound through all speakers and headphones connected.

“MUTING” appears on the display and the volume turns off (the volume level indicator goes off).



To restore the sound, press **MUTING** again so that “OFF” appears on the display.

- Turning MASTER VOLUME on the front panel or pressing VOLUME +/- on the remote control also restores the sound.

## Reinforcing the Bass

You can boost the bass level.

### On the front panel ONLY:

Press **BASS BOOST (SOURCE NAME)** briefly to select the bass boost function.

- Each time you press the button, the bass boost function turns on (“BASSBOOST ON”) and off (“BASSBOOST OFF”).
  - Select “BASSBOOST ON” to activate the bass boost function. The BASS BOOST indicator lights up on the display.
  - Select “BASSBOOST OFF” to cancel it. The indicator goes off.



### Note:

This function affects the front speaker sounds only.

## Attenuating the Input Signal

When the input level of the playing source is too high, the sounds will be distorted. If this happens, you need to attenuate the input signal level to prevent the sound distortion.

### On the front panel ONLY:

Press and hold **INPUT ATT. (SOUND SELECT)** so that the **ATT** indicator lights up on the display.

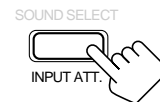

- Each time you press and hold the button, the Input Attenuator mode turns on (“INPUT ATT ON”) or off (“INPUT NORMAL”).

### Notes:

- This function is available only for the sources connected using the analog terminals.
- This function takes effect when the DSP mode is in use.
- When selecting “DVD MULTI” as the source, this effect does not work.

## Adjusting the Subwoofer Output Level

You can adjust the subwoofer output level if you have selected “YES” for the “SUBWOOFER” (see page 14).

Once it has been adjusted, the receiver memorizes the adjustment.

### Before you start, remember...

- There is a time limit in doing the following steps. If the setting is canceled before you finish, start from step 1 again.
- When the front speakers are all deactivated, the subwoofer level cannot be adjusted.

### On the front panel:

1. Press **(BALANCE/) SURROUND ADJUST** repeatedly until “SUBWFR LEVEL” appears on the display.



The display changes to show the current setting.

2. Turn **MULTI JOG** to adjust the subwoofer output level (–10 dB to +10 dB).

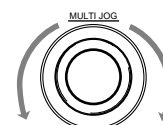

### From the remote control:

1. Press **SOUND**.

The 10 keys are activated for sound adjustments.

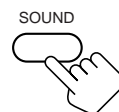

2. Press **SUBWOOFER –/+** to adjust the subwoofer output level (–10 dB to +10 dB).

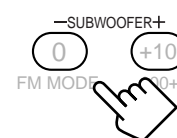



# Basic Settings

Some of the following settings are required after connecting and positioning your speakers in your listening room, while others will make operations easier.

## IMPORTANT:

When using the remote control, check to see if its remote control mode selector is set to the correct position:

To operate this receiver, set it to "AUDIO/TV/VCR."

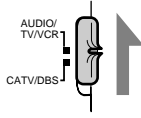

## 2. Turn MULTI JOG to adjust the balance.

- Turning it clockwise decreases the left channel output.
- Turning it counterclockwise decreases the right channel output.

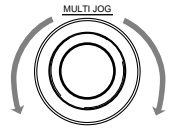

## Recording a Source

### For analog-to-analog recording

You can record any analog source through the receiver to —

- the cassette deck (or MD recorder) connected to the TAPE/MD jacks, and
  - the VCR connected to the VCR jacks
- at the same time.

### For digital-to-digital recording

You can record the currently selected digital input through the receiver to a digital recording device connected to the DIGITAL OUT terminal.

#### Notes:

- Analog-to-digital and digital-to-analog recordings are not possible.
- The output volume level, bass boost (see page 12), SEA modes (see page 20), and DSP modes (see page 21) cannot affect the recording.
- The test tone signal (see page 25, 26) does not come out through the DIGITAL OUT terminal.

## Adjusting the Front Speaker Output Balance

If the sounds you hear from the front right and left speakers are unequal, you can adjust the speaker output balance.

### Before you start, remember...

- There is a time limit in doing the following steps. If the setting is canceled before you finish, start from step 1 again.

### On the front panel ONLY:

1. Press **BALANCE (/SURROUND) ADJUST** repeatedly until "L/R BALANCE" appears on the display.

The display changes to show the current setting.



## Changing the Source Name

When you have connected an MD recorder to the TAPE/MD jacks or the DBS tuner to the TV SOUND/DBS jacks on the rear panel, change the source name which will be shown on the display when you select the MD recorder or DBS tuner as the source.

### On the front panel ONLY:

1. When changing the source name from "TAPE" to "MD":

- Turn **SOURCE SELECTOR** until "TAPE" appears.

When changing the source name from "TV SOUND" to "DBS":

- Turn **SOURCE SELECTOR** until "TV SOUND" appears.

2. Press and hold **SOURCE NAME (BASS BOOST)** until "ASSGN. MD" or "ASSGN. DBS" appears on the display.

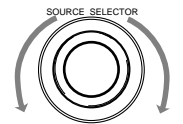

To change the source name to "TAPE" or "TV SOUND," repeat the same procedure above — in step 1, select "MD" or "DBS" then press and hold SOURCE NAME (BASS BOOST).

### Note:

Without changing the source name, you can still use the connected components. However, there may be some inconvenience.

- "TAPE" or "TV SOUND" will appear on the display when you select the MD recorder or DBS tuner.
- You cannot use the digital input (see page 16) for the MD recorder.
- You cannot use the COMPU LINK remote control system (see page 35) to operate the MD recorder.

## Setting the Subwoofer Information

Register whether or not you have connected a subwoofer.

**Before you start, remember...**

- There is a time limit in doing the following steps. If the setting is canceled before you finish, start from step 1 again.

**On the front panel ONLY:**

1. Press **SETTING** repeatedly until **"SUBWOOFER"** appears on the display.

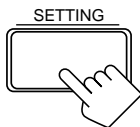

The display changes to show the current setting.

2. Turn **MULTI JOG** to register whether you have connected a subwoofer or not.

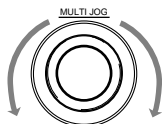

- As you turn it, the subwoofer setting alternates between "YES" and "NO."

<b>YES:</b>	Select this when a subwoofer is used. <b>[SUBWFR]</b> lights up on the display (see page 11).
<b>NO:</b>	Select this when no subwoofer is used.

## Setting the Speakers for the DSP Modes

To obtain the best possible surround sound of the DSP modes, you have to register the information about the speakers arrangement after all connections are completed.

**Before you start, remember...**

- There is a time limit in doing the following steps. If the setting is canceled before you finish, start from step 1 again.

### Front, Center, and Rear Speaker Setting

Register the sizes of all the connected speakers.

- When you change your speakers, you need to register the information about the speakers again.

**On the front panel ONLY:**

1. Press **SETTING** repeatedly until **"FRONT SPK"** (Front Speaker), **"CENTER SPK"** (Center Speaker) or **"REAR SPK"** (Rear Speaker) appears on the display.

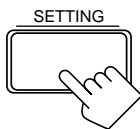

The display changes to show the current setting.

2. Turn **MULTI JOG** to select the appropriate item about the speaker selected in the above step.

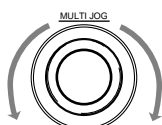

- As you turn it, the display changes to show the following:

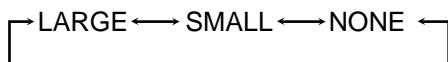

<b>LARGE:</b>	Select this when the speaker size is relatively large.
<b>SMALL:</b>	Select this when the speaker size is relatively small.
<b>NONE:</b>	Select this when you have not connected a speaker. (Not selectable for the front speakers.)

3. Repeat steps 1 and 2 to select the appropriate items for the other speakers.

**Notes:**

- Keep the following comment in mind as reference when adjusting.
  - If the size of the cone speaker unit built in your speaker is greater than 12 cm, select "LARGE," and if it is smaller than 12 cm, select "SMALL."
- If you have selected "NO" for the subwoofer setting, you can only select "LARGE" for the front speaker setting.
- If you have selected "SMALL" for the front speaker setting, you cannot select "LARGE" for the center and rear speaker settings.

### Center Delay Time Setting

Register the delay time of the sound from the center speaker, comparing to that of the sound from the front speakers.

If the distance from your listening point to the center speaker is equal to that to the front speakers, select 0 msec. As the distance to the center speaker becomes shorter, increase the delay time.

- 1 msec increase (or decrease) in delay time corresponds to 30 cm decrease (or increase) in distance.
- When shipped from the factory, delay time is set to 0 msec.

**On the front panel ONLY:**

1. Press **SETTING** repeatedly until **"CENTER DELAY"** appears on the display.

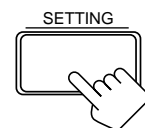

The display changes to show the current setting.

2. Turn **MULTI JOG** to select the delay time of the center speaker output.

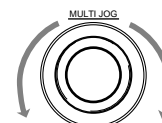

- Turn it clockwise to increase the delay time from 0 msec ("C. DELAY: 0ms") to 5 msec ("C. DELAY: 5ms").
- Turn it counterclockwise to decrease the delay time from 5 msec ("C. DELAY: 5ms") to 0 msec ("C. DELAY: 0ms").

**Notes:**

- Center delay time setting is not valid for the DVD MULTI playback mode.
- You cannot adjust the center delay time when you have set "CENTER SPK" to "NONE."

### Rear Delay Time Setting

Register the delay time of the sound from the rear speakers, comparing to that of the sound from the front speakers.

If the distance from your listening point to the rear speakers is equal to that to the front speakers, select 0 msec. As the distance to the rear speakers becomes shorter, increase the delay time.

- 1 msec increase (or decrease) in delay time corresponds to 30 cm decrease (or increase) in distance.
- Rear delay time for Dolby Digital, DTS Digital Surround and MPEG Multichannel is to be set to 5 msec.
- When shipped from the factory, delay time is set to 5 msec.

**On the front panel ONLY:**

1. Press **SETTING** repeatedly until **"REAR DELAY"** appears on the display.

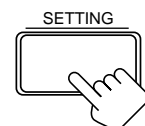

The display changes to show the current setting.

## 2. Turn MULTI JOG to select the delay time of the rear speaker output.

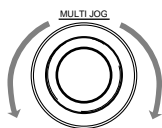

- Turn it clockwise to increase the delay time from 0 msec ("R. DELAY: 0ms") to 15 msec ("R. DELAY: 15ms").
- Turn it counterclockwise to decrease the delay time from 15 msec ("R. DELAY: 15ms") to 0 msec ("R. DELAY: 0ms").

### Notes:

- Rear delay time setting is not valid for the DVD MULTI playback mode.
- You cannot adjust the rear delay time when you have set "REAR SPK" to "NONE."

## Crossover Frequency Setting

Small speakers cannot reproduce the bass sound very well. So, if you have used a small speaker for any of the front, center, and rear channels, this receiver automatically reallocate the bass elements, originally assigned to the channel for which you have connected the small speaker, to another channel (for which you have connected the large speaker).

To use this function properly, you need to set the crossover frequency level according to the size of the small speaker connected.

- If you have selected "LARGE" for all speakers (see page 14), this function is set to "OFF" and cannot be adjusted.

### On the front panel ONLY:

#### 1. Press SETTING repeatedly until "CROSSOVER FRQ" (Crossover Frequency) appears on the display.

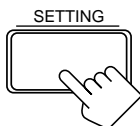

The display changes to show the current setting.

#### 2. Turn MULTI JOG to select the crossover frequency level according to the size of the small speaker connected.

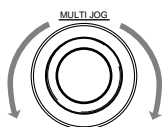

- As you turn it, the display changes to show the following:

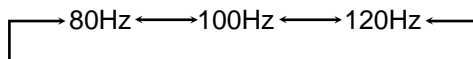

- Use the following comments as reference when adjusting.

**80Hz:** Select this when the cone speaker unit built in the speaker is about 12 cm.

**100Hz:** Select this when the cone speaker unit built in the speaker is about 10 cm.

**120Hz:** Select this when the cone speaker unit built in the speaker is about 8 cm.

### Note:

Crossover frequency setting is not valid for the DVD MULTI playback mode, 3D-PHONIC mode, and HEADPHONE mode.

## Low Frequency Effect Attenuator Setting

If the bass sound is distorted while playing back a source using Dolby Digital, DTS Digital Surround or MPEG Multichannel follow the procedure below.

### On the front panel ONLY:

#### 1. Press SETTING repeatedly until "LFE ATT" (Low Frequency Effect Attenuator) appears on the display.

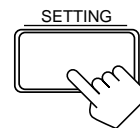

The display changes to show the current setting.

#### 2. Turn MULTI JOG to select the low frequency effect attenuator level.

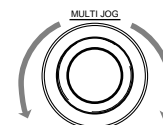

- As you turn it, the display changes to show the following:

0dB ←→ 10dB

**0dB:** Normally select this.

**10dB:** Select this when the bass sound is distorted.

### Note:

Low frequency effect attenuator setting is not valid for the DVD MULTI playback mode.

## Dynamic Range Compression Setting

You can compress the dynamic range (difference between maximum sound and minimum sound) of the reproduced sound. This is useful when enjoying surround sound at night.

- This function takes effect only when playing back a source using Dolby Digital.

### On the front panel ONLY:

#### 1. Press SETTING repeatedly until "D. RANGE COMP." (Dynamic Range Compression) appears on the display.

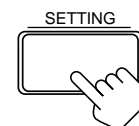

The display changes to show the current setting.

#### 2. Turn MULTI JOG to select the appropriate item about the compression level.

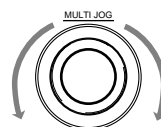

- As you turn it, the display changes to show the following:

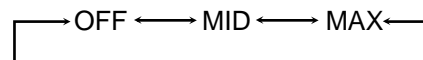

**OFF:** Select this when you want to enjoy surround with its full dynamic range. (No effect applied.)

**MID:** Select this when you want to reduce the dynamic range a little. (Factory setting.)

**MAX:** Select this when you want to apply the compression effect fully. (Useful at night.)

### Note:

Dynamic Range Compression setting is not valid for the DTS Digital Surround, MPEG Multichannel and DVD MULTI playback mode.

## Digital Input (DIGITAL IN) Terminal Setting

When you use the digital input terminals, you have to register what components are connected to which terminals (DIGITAL IN 1/2/3).

Before you start, remember...

- There is a time limit in doing the following steps. If the setting is canceled before you finish, start from step 1 again.

**On the front panel ONLY:**

1. Press **SETTING** repeatedly until “DIGITAL IN” appears on the display.

The display changes to show the current setting.

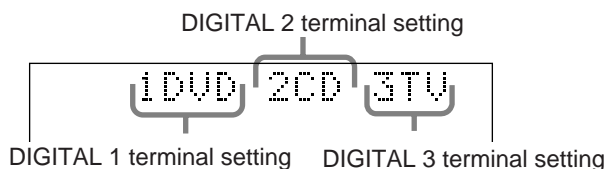

2. Turn **MULTI JOG** to select the appropriate digital terminal setting.

- As you turn it, the display changes to show the following:

1 DVD 2 CD 3 TV (or DBS\*) ⇐  
 1 DVD 2 CD 3 MD ⇐  
 1 DVD 2 MD 3 TV (or DBS\*) ⇐  
 1 CD 2 DVD 3 TV (or DBS\*) ⇐  
 1 CD 2 DVD 3 MD ⇐  
 1 CD 2 MD 3 TV (or DBS\*) ⇐  
 1 TV (or DBS\*) 2 CD 3 DVD ⇐  
 1 TV (or DBS\*) 2 CD 3 MD ⇐  
 1 TV (or DBS\*) 2 DVD 3 MD ⇐  
 1 MD 2 CD 3 TV (or DBS\*) ⇐  
 1 MD 2 CD 3 DVD ⇐  
 1 MD 2 DVD 3 TV (or DBS\*) ⇐  
 (back to the beginning)

\* If you have changed the source name from “TV SOUND” to “DBS,” “DBS” appears.

**Note:**

When shipped from the factory, the DIGITAL IN terminals can be used as the digital input for the following components.

- DIGITAL 1 (coaxial): For DVD player
- DIGITAL 2 (optical): For CD player
- DIGITAL 3 (optical): For digital TV broadcast tuner

## Selecting the Analog or Digital Input Mode

When you have connected some digital source components using the digital terminals (see page 8), you need to change the input mode for these components to the appropriate digital input mode correctly — AUTO/PCM, DOLBY DIGITAL, DTS, or MPEG.

Before you start, remember...

- The digital input (DIGITAL IN) terminal setting should be correctly done for the sources you want to select the digital input mode for. Without setting this digital input terminal correctly, you cannot change the input mode from analog input to digital input even if you follow the procedure below.

**On the front panel:**

1. Turn **SOURCE SELECTOR** until the source (CD, MD, TV SOUND, DBS, or DVD)\* for which you want to change the input mode appears on the display.

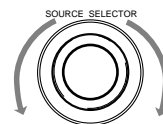

**Note:**

\* Among the sources listed above, you can select the digital input only for the sources which you have selected the digital input terminals for. (See “Digital Input (DIGITAL IN) Terminal Setting.”)

2. Press **INPUT ANALOG/DIGITAL** repeatedly until the digital input mode you want appears on the display.

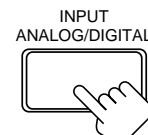

- Each time you press the button, the input mode changes as follows:

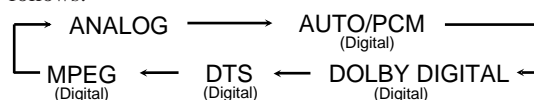

Normally select “AUTO/PCM,” so the receiver automatically detects the incoming digital signal format. (The DIGITAL AUTO indicator lights up on the display.)

- When the receiver can recognize the digital signal format coming into the receiver, the frame of the digital signal indicator for the detected signal lights up automatically.
- When the receiver cannot recognize the incoming signal format correctly, the frame of the digital signal indicator flashes.

If this happens, select the same digital input mode with the incoming digital signal — either “DOLBY DIGITAL”, “DTS” or “MPEG.”

To change the input mode back to analog input, select “ANALOG.”

**From the remote control:**

1. Press the source selecting button (CD, TAPE/MD, TV/DBS, or DVD)\* for which you want to change the input mode.

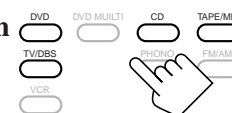

**Note:**

\* Among the sources listed above, you can select the digital input only for the sources which you have selected the digital input terminals for. (See “Digital Input (DIGITAL IN) Terminal Setting.”)

2. Press **ANALOG/DIGITAL** to change the input mode.



- Each time you press the button, the input mode changes as follows:

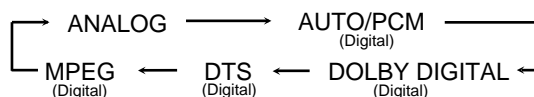

**Notes:**

- Noise may come out of the speakers while searching or skipping a multi-sound source encoded with Dolby Digital, DTS Digital Surround or MPEG Multichannel. If this happens, select “DOLBY DIGITAL”, “DTS” or “MPEG” for digital input mode.
- When you change the source, the digital input mode will be automatically reset to “AUTO/PCM.”



## Showing the Text Information on the Display

When you have connected an MD recorder or CD player equipped with TEXT COMPU LINK remote control system (see page 36), you can show the text information, such as disc title or track title, on the display of this receiver. To show it on the display, follow the procedure below.

### Before you start, remember...

- There is a time limit in doing the following steps. If the setting is canceled before you finish, start from step 1 again.

### On the front panel ONLY:

1. Press **SETTING** repeatedly until “**FL DISPLAY**” appears on the display.

The display changes to show the current setting.

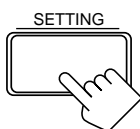

2. Turn **MULTI JOG** to select either the source name or the text information to be shown on the display.

- As you turn it, the display changes to show the following:

NORMAL ←→ TEXT

**NORMAL:** Source name appears during play.

**TEXT:** Text information appears during play.

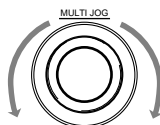

### Note:

Though you have selected “TEXT,” the source name such as “CD” or “MD” appears if a playing disc has no text information.

## Setting the AM Tuner Interval Spacing

Some countries space AM stations 9 kHz apart, and other countries use 10 kHz spacing.

### On the front panel ONLY:

#### To select the 10 kHz interval:

Be sure the receiver is turned off, but is plugged into an AC outlet. Hold down **TUNER PRESET** and press **STANDBY/ON** . Now the 10 kHz interval is selected.

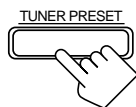

and

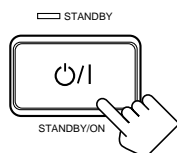

#### To change back to the 9 kHz interval:

Be sure the receiver is turned off, but is plugged into an AC outlet. Hold down **FM MODE** and press **STANDBY/ON** . Now the 9 kHz interval is selected.

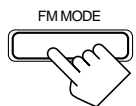

and

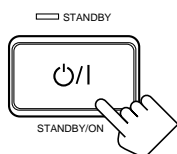

## Storing the Basic Settings and Adjustments — One Touch Operation

JVC's One Touch Operation function is used to assign and store different sound settings for each different playing source. By using this function, you do not have to change the settings every time you change the source. The stored settings for the newly selected source are automatically recalled. The following can be stored for each source:

- Volume level (see page 11)
- Bass boost (see page 12)
- Input attenuator mode (see page 12)
- Subwoofer output level (see page 12)
- Balance (see page 13)
- SEA modes (see page 20)
- DSP modes
  - 3D-PHONIC mode settings (see page 24)
  - DAP mode settings (see page 24)
  - Surround mode settings (see page 25)
- DVD MULTI playback mode settings (see page 29)

### On the front panel ONLY:

#### To store the sound settings

1. Press **ONE TOUCH OPERATION**.

The ONE TOUCH OPERATION lamp lights up, then the previously memorized settings are recalled.



2. Adjust the sound using the functions listed above.

The newly adjusted settings are memorized.

#### To recall the sound settings

With the ONE TOUCH OPERATION lamp lit, the settings for the currently selected source are recalled when the source is selected.

#### To cancel the One Touch Operation function

Press ONE TOUCH OPERATION so that the lamp goes off.

(Even though the One Touch Operation function is canceled, the recalled sound effects remain active.)

### Notes:

- If the source is FM or AM, you can assign a different setting for each band.
- The DSP modes and DVD MULTI playback mode cannot be used at the same time.

## Using the Sleep Timer

Using the Sleep Timer, you can fall asleep to music and know the receiver will turn off by itself rather than play all night.

### From the remote control ONLY:

#### Press SLEEP repeatedly.

The SLEEP indicator lights up on the display, and the shut-off time changes as follows (in minutes):

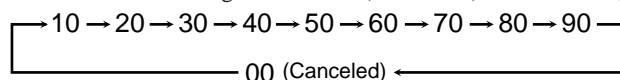

#### When the shut-off time comes

The receiver turns off automatically.

#### To check or change the time remaining until the shut-off time

Press SLEEP once.

The remaining time until the shut-off time appears in minutes.

- To change the shut-off time, press SLEEP repeatedly.

#### To cancel the Sleep Timer

Press SLEEP repeatedly until “SLEEP 00min.” appears on the display. (The SLEEP indicator goes off.)

- Turning off the power also cancels the Sleep Timer.

# Receiving Radio Broadcasts

You can browse through all the stations or use the preset function to go immediately to a particular station.

## IMPORTANT:

When using the remote control, check to see if its remote control mode selector is set to the correct position:

To operate this receiver, set it to "AUDIO/TV/VCR."

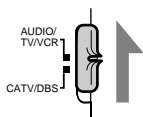

## Using Preset Tuning

Once a station is assigned to a channel number, the station can be quickly tuned. You can preset up to 30 FM and 15 AM stations.

### To store the preset stations

Before you start, remember...

- There is a time limit in doing the following steps. If the setting is canceled before you finish, start from step 1 again.

### On the front panel ONLY:

#### 1. Tune in the station you want to preset (see "Tuning in Stations Manually").

- If you want to store the FM reception mode for this station, select the FM reception mode you want. See "Selecting the FM Reception Mode" on page 19.

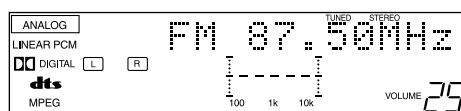

#### 2. Press TUNER (/SEA) MEMORY.

"CH-" appears and the channel number position starts flashing on the display for about 10 seconds.

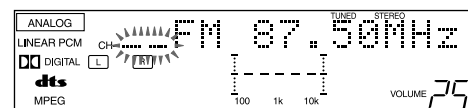

#### 3. Turn MULTI JOG to select a channel number while the channel number position is flashing.

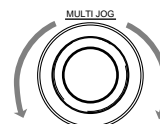

### Note:

You can use the 10 keys on the remote control to select the preset number. When using the 10 keys, be sure that they are activated for the tuner, not for the CD and others. (See page 43.)

#### 4. Press TUNER (/SEA) MEMORY again while the selected channel number is flashing on the display.

The selected channel number stops flashing. The station is assigned to the selected channel number.

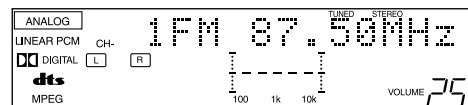

#### 5. Repeat steps 1 to 4 until you store all the stations you want.

### To erase a stored preset station

Storing a new station on a used number erases the previously stored one.

## Tuning in Stations Manually

Before you start, remember...

- Check the AM tuner interval spacing (9 kHz or 10 kHz) for your area. (See page 17.)

### On the front panel:

#### 1. Turn SOURCE SELECTOR to select the band (FM or AM).

The last received station of the selected band is tuned in.

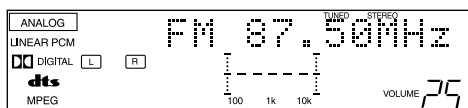
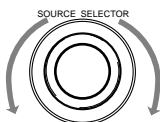

#### 2. Press FM/AM TUNING.

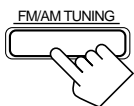

#### 3. Turn MULTI JOG until you find the frequency you want.

- Turning it clockwise increases the frequency.
- Turning it counterclockwise decreases the frequency.
- When you turn MULTI JOG quickly, the frequency keeps changing until a station is tuned in.

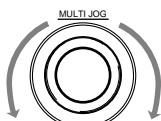

### From the remote control:

#### 1. Press FM/AM to select the band.

- Each time you press the button, the band alternates between FM and AM.

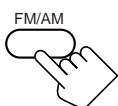

#### 2. Press TUNING UP or TUNING DOWN repeatedly until you find the frequency you want.

- When you hold the button (and release it), the frequency keeps changing until a station is tuned in.

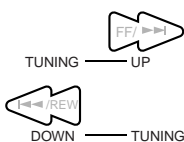

### Note:

When a station of sufficient signal strength is tuned in, the TUNED indicator lights up on the display.

When an FM stereo program is received, the STEREO indicator also lights up.

## To tune in a preset station

### On the front panel:

#### 1. Turn SOURCE SELECTOR to select the band (FM or AM).

The last received station of the selected band is tuned in.

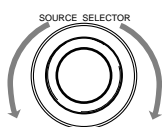

#### 2. Press TUNER PRESET.

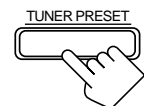

#### 3. Turn MULTI JOG until you find the channel you want.

- Turning it clockwise increases the channel numbers.
- Turning it counterclockwise decreases the channel numbers.



### From the remote control:

#### 1. Press FM/AM.

- Each time you press the button, the band alternates between FM and AM.

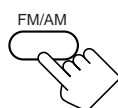

#### 2. Press the 10 keys to select a preset channel number.

- For channel number 5, press 5.
- For channel number 15, press +10 then 5.
- For channel number 20, press +10 then 10.
- For channel number 30, press +10, +10, then 10.

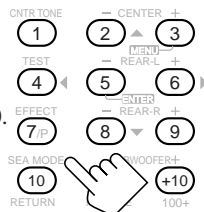

### Note:

When you use the 10 keys on the remote control, be sure that they are activated for the tuner, not for the CD and others. (See page 43.)

## Selecting the FM Reception Mode

### When an FM stereo broadcast is hard to receive or noisy

You can change the FM reception mode while receiving an FM broadcast.

- You can store the FM reception mode for each preset station.

#### Press FM MODE on the front panel or on the remote control.

- Each time you press the button, the FM reception mode alternates between "AUTO MUTING" and "MONO."

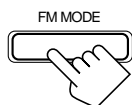

On the front panel



On the remote control

**AUTO MUTING:** When a program is broadcasted in stereo, you will hear stereo sound; when in monaural, you will hear monaural sounds. This mode is also useful to suppress static noise between stations. The AUTO MUTING indicator lights up on the display.

**MONO:** Reception will be improved although you will lose the stereo effect. In this mode, you will hear noise while tuning into the stations. The AUTO MUTING indicator goes off on the display.

### Note:

When using the FM MODE button on the remote control, be sure that the 10 keys are activated for the tuner, not for the CD and others. (See page 43.)

## Assigning Names to Preset Stations

You can assign a name of up to four characters to each preset station. When a preset station is tuned in, its assigned name will appear on the display.

### Before you start, remember...

- There is a time limit in doing the following steps. If the setting is canceled before you finish, start from step 1 again.
- You can use the following characters: Space ( ), A – Z, and 0 – 9.

### On the front panel ONLY:

#### 1. Tune in a preset station.

See the left.

#### 2. Press TUNER (/SEA) MEMORY.

The preset channel number starts flashing for about 10 seconds.



- If you turn MULTI JOG while the preset channel number is flashing, you can change the preset channel number.

#### 3. Press TUNER PRESET, while the preset channel number is flashing.

The first character position starts flashing.

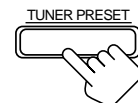

#### 4. Turn MULTI JOG to select the first character, while the first character position is flashing.

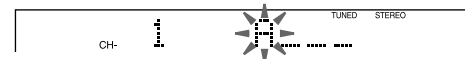
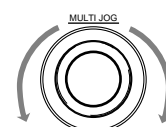

#### 5. Press TUNER PRESET, while a character you want is flashing.

The next character position starts flashing.

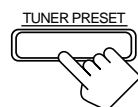

#### 6. Repeat steps 4 and 5 to enter up to four characters.

#### 7. Press TUNER (/SEA) MEMORY while the last selected character is flashing after you have assigned a name.



### To erase the input characters

Insert spaces using the same procedure described above.



# Using the SEA Modes

The SEA (Sound Effect Amplifier) modes give you control of the way your music sounds.

## IMPORTANT:

When using the remote control, check to see if its remote control mode selector is set to the correct position:

To operate this receiver, set it to "AUDIO/TV/VCR."

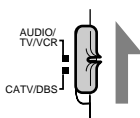

## Selecting Your Favorite SEA Mode

### On the front panel:

Press SEA MODE repeatedly until the SEA mode you want appears on the display.

- Each time you press the button, the SEA mode changes as follows:

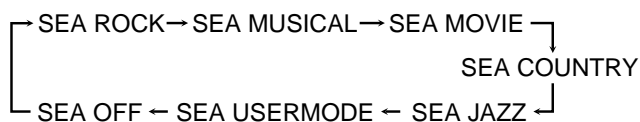

<b>SEA ROCK:</b>	Gives a heavy sound. Both high and low frequencies are boosted.
<b>SEA MUSICAL:</b>	Enhances the mid-frequency range, which the human voice is mostly made up of.
<b>SEA MOVIE:</b>	Adds breadth to sounds so you feel like you are in a movie theater.
<b>SEA COUNTRY:</b>	Enhances the high-frequency range so that instruments such as the violin and banjo are emphasized.
<b>SEA JAZZ:</b>	Gives a feeling of a live atmosphere. Good for acoustic music.
<b>SEA USERMODE:</b>	Your original SEA adjustment (see the right).
<b>SEA OFF:</b>	No SEA mode is applied (see below).

### Notes:

- The SEA modes cannot be used for recording.
- When the SEA mode is turned on, the SEA indicator lights up on the display.
- When the SEA mode is used with the DAP mode (see page 24), sounds may be distorted. If this happens, turn off the DAP mode or decrease the effect level of the DAP mode.

### To cancel the SEA mode

Press SEA MODE repeatedly until "SEA OFF" appears. The SEA indicator goes off from the display.

### From the remote control:

#### 1. Press SOUND.

The 10 keys are activated for sound adjustments.

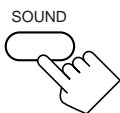

#### 2. Press SEA MODE repeatedly until the SEA mode you want appears on the display.



### To cancel the SEA mode

Press SEA MODE repeatedly until "SEA OFF" appears in step 2 above. The SEA indicator goes off from the display.

## Creating Your Own SEA Mode

You can adjust and store your own SEA adjustment into memory (SEA USERMODE).

### Before you start, remember...

- There is a time limit in doing the following steps. If the setting is canceled before you finish, start from step 1 again.

### On the front panel ONLY:

If you do not want to store your adjustment, but rather want to adjust the SEA temporarily, skip step 4 below.

- Press SEA ADJUST repeatedly until the frequency range (100 Hz, 1 kHz or 10 kHz) you want appears on the display.

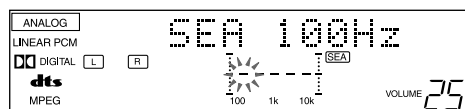
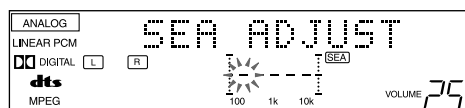

- Turn MULTI JOG to adjust the SEA level of the selected frequency range.

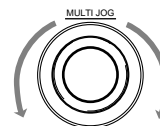

- Turning it clockwise increases the level.
- Turning it counterclockwise decreases the level.

- Repeat step 1 and 2 to adjust other frequency ranges if necessary.

- Press (TUNER/) SEA MEMORY.

Your adjustment is stored into the SEA USERMODE.

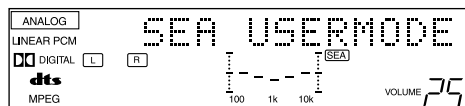

### To recall your own SEA adjustment

Press SEA MODE repeatedly until "SEA USERMODE" appears.

### To erase a stored adjustment

Storing a new adjustment into SEA USERMODE erases the previously stored one.

# Using the DSP Modes

The built-in Surround Processor provides three types of the DSP (Digital Signal Processor) mode — 3D-PHONIC mode, DAP (Digital Acoustic Processor) mode and Surround mode.

## 3D-PHONIC modes

The 3D-PHONIC mode gives you such a nearly surround effect as is reproduced through the Dolby Surround decoder, which is widely used to reproduce sounds with a feeling of movement like those experienced in movie theaters. The 3D-PHONIC mode is the result of research on sound localization technology carried out at JVC for many years. **This mode can be used when the front speakers are connected to this receiver (without respect to the rear/center speaker connection).**

---

**3D ACTION:** Best for action and war movies — where the action is fast and explosive.

---

**3D THEATER:** Reproduces the sound field of a large theater. This mode can be selected when only front speakers are connected to this receiver and “REAR SPK” and “CENTER SPK” are set to “NONE” (see page 14).

---

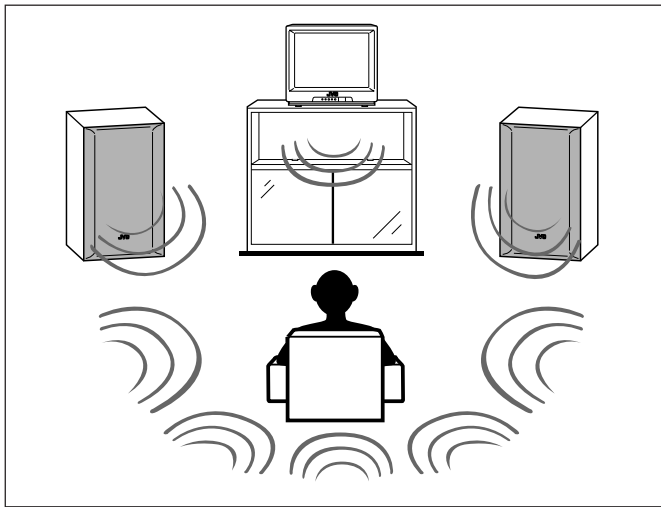

## DAP modes

The sound heard in a concert hall or club consists of direct sound and indirect sound — early reflections and reflections from behind. Direct sounds reach the listener directly without any reflection. On the other hand, indirect sounds are delayed by the distances of the ceiling and walls. These direct sounds and indirect sounds are the most important elements of the acoustic surround effects. The DAP mode can create these important elements, and gives you a real “being there” feeling. **This mode can be used when the front speakers are connected to this receiver (without respect to the rear/center speaker connection).**

You can select one of the following to your preference while playing an analog or linear PCM source.

---

**LIVE CLUB:** Gives the feeling of a live music club with a low ceiling.

---

**DANCE CLUB:** Gives a throbbing bass beat.

---

**HALL:** Gives clear vocal and the feeling of a concert hall.

---

**PAVILION:** Gives the spacious feeling of a pavilion with a high ceiling.

---

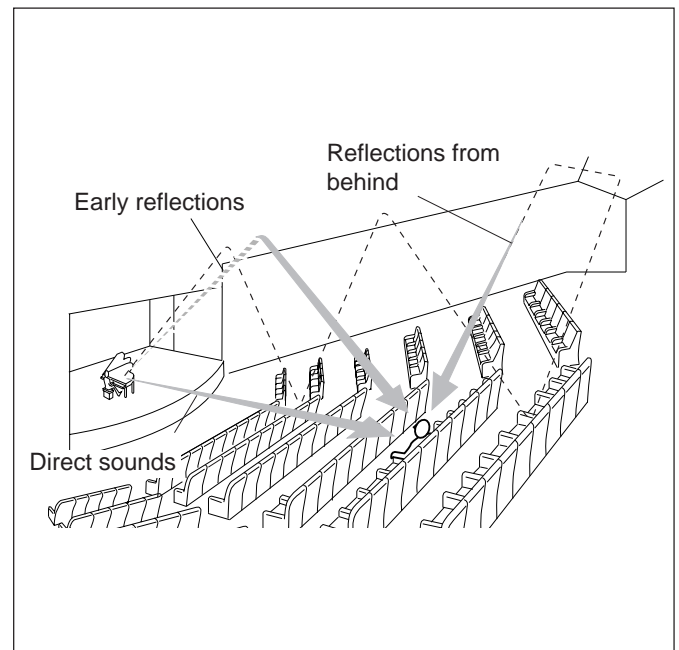

## Surround modes

With this receiver, you can use four types of the Surround mode. **Following modes cannot be used when only the front speakers are connected to this receiver (without the rear speakers or center speaker).**

### **Dolby Surround (Dolby Digital and Dolby Pro Logic)\***

Used to watch the soundtracks of software encoded with Dolby Digital (bearing the mark ) or with Dolby Surround (bearing the mark .

Dolby Surround encoding format records the left front channel, right front channel, center channel, and rear channel (total 4 channels) signals into 2 channels. The Dolby Pro Logic decoder built in this receiver decode these 2 channel signals into original 4 channel signals — matrix-based multichannel reproduction, and allows you to enjoy the realistic stereo sounds in your listening room.

On the other hand, Dolby Digital encoding method (so called a discrete 5.1 channel digital audio format) records and compresses the left front channel, right front channel, center channel, left rear channel, right rear channel, and LFE channel (total 6 channels, but LFE channel is counted as 0.1 channel, therefore called 5.1 channels) signals digitally. Each channel is completely independent from other channel signals to avoid interference, therefore, you can obtain much better sound quality with much stereo and surround effects.

The Dolby Digital decoder built in this receiver can create much more realistic sound field in your listening room. You may feel as if you were in a real theater.

In addition, Dolby Digital enables stereo rear sounds, and sets the cutoff frequency of the rear treble at 20 kHz, comparing to 7 kHz for Dolby Pro Logic. These facts enhance the sound movement and being-there feelings much more than Dolby Pro Logic.

- To enjoy the software encoded with Dolby Digital, you must connect the source component using the digital terminal on the rear of this receiver. (See page 8.)

### **DTS Digital Surround\*\***

DTS Digital Surround is another discrete 5.1 channel digital audio format available on CD, LD, and DVD software.

Comparing to Dolby Digital, audio compression rate is relatively low. This fact allows DTS Digital Surround format to have more data recorded than Dolby Digital even using the same media, and to add breadth and depth to the reproduced sounds. As a result, DTS Digital Surround features natural, solid and clear sound.

- To enjoy the software encoded with DTS Digital Surround, you must connect the source component using the digital terminal on the rear of this receiver. (See page 8.)

### **MPEG Multichannel**

MPEG Multichannel is another discrete 5.1 channel digital audio format available on DVD software, and uses encoding method called MPEG2-Audio. (MPEG stands for “Motion Picture Expert Group” and has been originally developed for compressing video signals.) To watch the soundtracks of video software bearing the mark , the receiver can provide you with MPEG Multichannel decoder.

MPEG Multichannel is automatically selected according to software played back and the speaker arrangement you have done.

- To enjoy the software encoded with MPEG Multichannel, you must connect the source component using the digital terminal on the rear of this receiver. (See page 8.)

### **JVC Theater Surround**

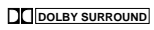
In order to reproduce a more realistic sound field in your listening room while playing soundtracks of software encoded with Dolby Surround (bearing the mark ) you can use JVC Theater Surround.

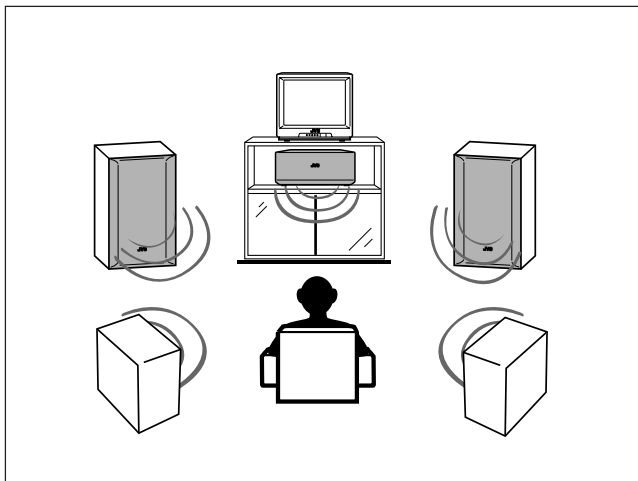

#### **Notes:**

- The DSP modes have no effect on monaural sources.
- When you select “DVD MULTI” as the source to play, you cannot select or adjust the DSP modes.
- The  PRO LOGIC indicator lights up when the Dolby Pro Logic decoder built in this receiver is activated.

### **DVD MULTI Playback Mode**

This receiver provides the DVD MULTI playback mode for reproducing the analog discrete 5.1 channel output mode of the DVD player or other equipment.

You can adjust the DVD MULTI playback mode while playing back a video software such as a DVD using the analog discrete 5.1 channel output mode.

- For the DVD MULTI playback mode connection, see page 7.
- For details on the DVD MULTI playback mode, see page 29.

\* Manufactured under license from Dolby Laboratories. “Dolby,” “Pro Logic,” and the double-D symbol are trademarks of Dolby Laboratories. Confidential Unpublished Works. ©1992–1997 Dolby Laboratories, Inc. All rights reserved.

\*\* Manufactured under license from Digital Theater Systems, Inc. US Pat. No. 5,451,942 and other world-wide patents issues and pending. “DTS” and “DTS Digital Surround” are trademarks of Digital Theater Systems, Inc. ©1996 Digital Theater Systems, Inc. All rights reserved.

## Available DSP Modes According to the Speaker Arrangement

Available DSP modes will vary depending on how many speakers are used with this receiver.  
**Make sure that you have set the speaker information correctly (see page 14).**

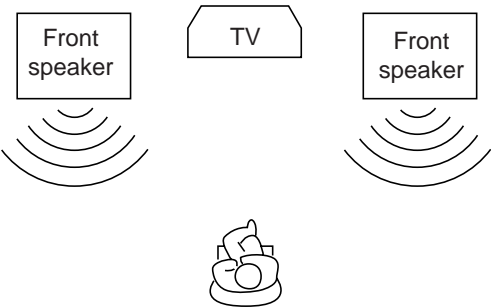
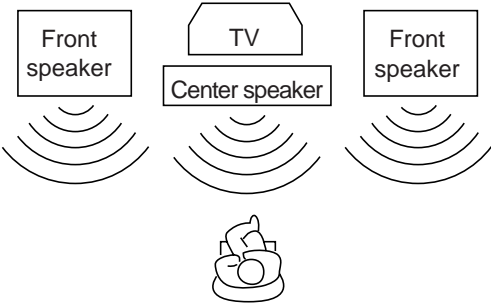
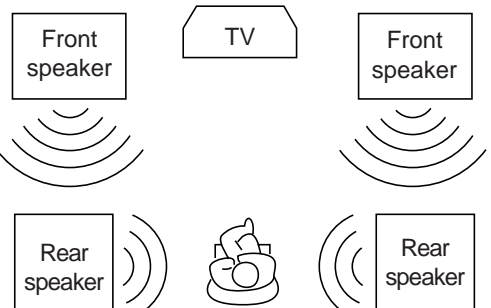
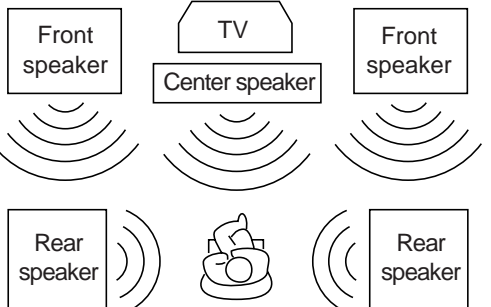
Speaker arrangements	Available DSP modes		
	<p>Each time you press DSP MODE on the front panel or SURROUND MODE on the remote control, the DSP modes change as follows:</p> <ul style="list-style-type: none"> <li>• 3D THEATER</li> <li>• LIVE CLUB</li> <li>• DANCE CLUB</li> <li>• HALL</li> <li>• PAVILION</li> <li>• 3D ACTION</li> <li>• DSP OFF (DSP mode is canceled)</li> </ul>		
	<p>Each time you press DSP MODE on the front panel or SURROUND MODE on the remote control, the DSP modes change as follows:</p> <table border="0" style="width: 100%;"> <tr> <td style="vertical-align: top; width: 50%;"> <p><b>By pressing DSP MODE:</b></p> <ul style="list-style-type: none"> <li>• THEATER</li> <li>• LIVE CLUB</li> <li>• DANCE CLUB</li> <li>• HALL</li> <li>• PAVILION</li> <li>• 3D ACTION</li> <li>• DSP OFF (DSP mode is canceled)</li> </ul> </td> <td style="vertical-align: top; width: 50%;"> <p><b>By pressing SURROUND MODE:</b></p> <ul style="list-style-type: none"> <li>• DOLBY/DTS/MPEG SURROUND (DOLBY PRO LOGIC, DOLBY DIGITAL*, DTS SURROUND**, or MPEG SURROUND***)</li> <li>• THEATER</li> <li>• LIVE CLUB</li> <li>• DANCE CLUB</li> <li>• HALL</li> <li>• PAVILION</li> <li>• 3D ACTION</li> <li>• DSP OFF (DSP mode is canceled)</li> </ul> </td> </tr> </table>	<p><b>By pressing DSP MODE:</b></p> <ul style="list-style-type: none"> <li>• THEATER</li> <li>• LIVE CLUB</li> <li>• DANCE CLUB</li> <li>• HALL</li> <li>• PAVILION</li> <li>• 3D ACTION</li> <li>• DSP OFF (DSP mode is canceled)</li> </ul>	<p><b>By pressing SURROUND MODE:</b></p> <ul style="list-style-type: none"> <li>• DOLBY/DTS/MPEG SURROUND (DOLBY PRO LOGIC, DOLBY DIGITAL*, DTS SURROUND**, or MPEG SURROUND***)</li> <li>• THEATER</li> <li>• LIVE CLUB</li> <li>• DANCE CLUB</li> <li>• HALL</li> <li>• PAVILION</li> <li>• 3D ACTION</li> <li>• DSP OFF (DSP mode is canceled)</li> </ul>
<p><b>By pressing DSP MODE:</b></p> <ul style="list-style-type: none"> <li>• THEATER</li> <li>• LIVE CLUB</li> <li>• DANCE CLUB</li> <li>• HALL</li> <li>• PAVILION</li> <li>• 3D ACTION</li> <li>• DSP OFF (DSP mode is canceled)</li> </ul>	<p><b>By pressing SURROUND MODE:</b></p> <ul style="list-style-type: none"> <li>• DOLBY/DTS/MPEG SURROUND (DOLBY PRO LOGIC, DOLBY DIGITAL*, DTS SURROUND**, or MPEG SURROUND***)</li> <li>• THEATER</li> <li>• LIVE CLUB</li> <li>• DANCE CLUB</li> <li>• HALL</li> <li>• PAVILION</li> <li>• 3D ACTION</li> <li>• DSP OFF (DSP mode is canceled)</li> </ul>		
	<div style="border: 1px solid black; padding: 5px; margin-bottom: 10px;"> <p><b>To activate the Surround mode</b>, press SURROUND ON/OFF button so that the lamp on the button lights up.</p> </div> <div style="border: 1px solid black; padding: 5px;"> <p><b>To activate the Surround mode</b>, you can also use the SURROUND ON/OFF button.</p> </div>		
	<p>* Activated automatically only when "AUTO/PCM" is selected as the digital input and playback source is encoded with Dolby Digital.</p> <p>** Activated automatically only when "AUTO/PCM" is selected as the digital input and playback source is encoded with DTS Digital Surround.</p> <p>*** Activated automatically only when "AUTO/PCM" is selected as the digital input and playback source is encoded with MPEG Surround.</p> <p><b>Notes:</b></p> <ul style="list-style-type: none"> <li>• If Surround mode is canceled while playing back a multichannel source such as Dolby Digital, DTS Digital Surround and MPEG Multichannel, all channel signals are mixed with left and right front channel and are output through the front speakers.</li> <li>• While playing back a multichannel source such as Dolby Digital, DTS Digital Surround and MPEG Multichannel, Theater Surround, DAP modes, and 3D-PHONIC modes cannot be used. On the other hands, if you select a Dolby Digital, DTS Digital Surround and MPEG Multichannel as the source to play while using any of Theater Surround, DAP modes, and 3D-PHONIC modes, the currently selected mode will be canceled and Dolby Digital, DTS Digital Surround or MPEG Multichannel mode will be activated.</li> </ul>		

**IMPORTANT:**

When using the remote control, check to see if its remote control mode selector is set to the correct position:

To operate this receiver, set it to "AUDIO/TV/VCR"

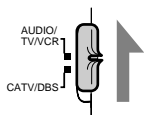

## Adjusting the 3D-PHONIC Modes

Once you have adjusted the 3D-PHONIC modes, the adjustment is memorized for each 3D-PHONIC mode.

Before you start, remember...

- Make sure that you have set the speaker information correctly (see page 14).
- There is a time limit in doing the following steps. If the setting is canceled before you finish, start from step 1 again.

**On the front panel:**

1. Press **DSP MODE** repeatedly until "3D ACTION" or "3D THEATER" appears on the display.

The 3D-PHONIC, DSP, and PRO LOGIC indicators also light up on the display.

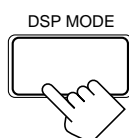

2. Adjust the effect level.

- 1) Press (BALANCE/) **SURROUND ADJUST** repeatedly until "DSP EFFECT" appears on the display. The display changes to show the current setting.
- 2) Turn **MULTI JOG** to select the effect level.
  - As you turn it, the effect level changes as follows:

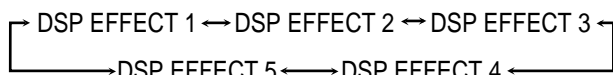
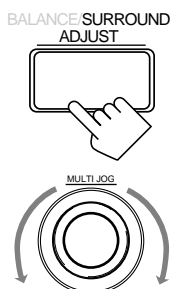

As the number increases, the selected 3D-PHONIC mode becomes stronger.

**From the remote control:**

1. Press **SURROUND MODE** repeatedly until "3D ACTION" or "3D THEATER" appears on the display.

The 3D-PHONIC, DSP, and PRO LOGIC indicators also light up on the display.



2. Press **SOUND**.

The 10 keys are activated for sound adjustments.

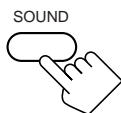

3. Press **EFFECT** to select an effect level you want.

- Each time you press the button, the effect level changes as follows:

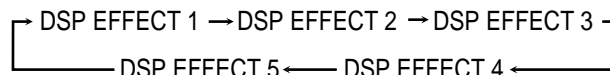

As the number increases, the selected 3D-PHONIC mode becomes stronger.

## Adjusting the DAP Modes

Once you have adjusted the DAP modes, the adjustment is memorized for each DAP mode.

Before you start, remember...

- Make sure that you have set the speaker information correctly (see page 14).
- There is a time limit in doing the following steps. If the setting is canceled before you finish, start from step 1 again.
- You cannot adjust the rear speaker output level when you have set "REAR SPK" to "NONE." See page 14.
- When the DAP mode is used with the SEA mode (see page 20), sounds may be distorted. If this happens, turn off the SEA mode.

**On the front panel:**

1. Press **DSP MODE** repeatedly until the DAP mode — **LIVE CLUB, DANCE CLUB, HALL, or PAVILION** — appears on the display.

The DSP indicator also lights up on the display.

- When you have set "REAR SPK" to "NONE," the 3D-PHONIC indicator also lights up.

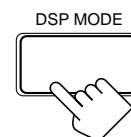

2. Adjust the speaker output levels.

- 1) Press (BALANCE/) **SURROUND ADJUST** repeatedly until one of the indications appears on the display.

"REAR L LEVEL":

To adjust the left rear speaker level.

"REAR R LEVEL":

To adjust the right rear speaker level.

- 2) Turn **MULTI JOG** to adjust the selected speaker output level (from -10 dB to +10 dB).
- 3) Repeat 1) and 2) to adjust the other speaker output level.

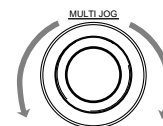



### 3. Adjust the effect level.

- 1) Press (BALANCE/SURROUND ADJUST) repeatedly until "DSP EFFECT" appears on the display. The display changes to show the current setting.
- 2) Turn MULTI JOG to select the effect level.
  - As you turn it, the effect level changes as follows:

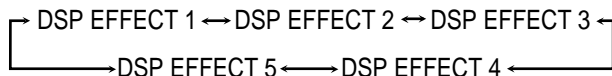
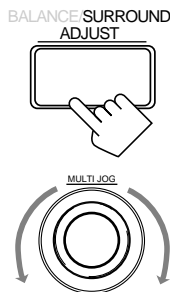

As the number increases, the selected DAP mode becomes stronger.

#### From the remote control:

1. Press SURROUND MODE repeatedly until the DAP mode — LIVE CLUB, DANCE CLUB, HALL, or PAVILION — appears on the display.

The DSP indicator also lights up on the display.

- When you have set "REAR SPK" to "NONE," the 3D-PHONIC indicator also lights up.



2. Press SOUND.

The 10 keys are activated for sound adjustments.

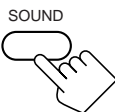

3. Adjust the speaker output levels.

- To adjust the left rear speaker level, press REAR•L +/- (from -10 dB to +10 dB).
- To adjust the right rear speaker level, press REAR•R +/- (from -10 dB to +10 dB).

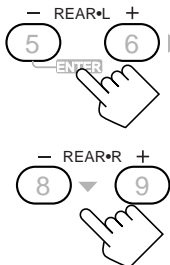

4. Press EFFECT to select an effect level you want.

- Each time you press the button, the effect level changes as follows:

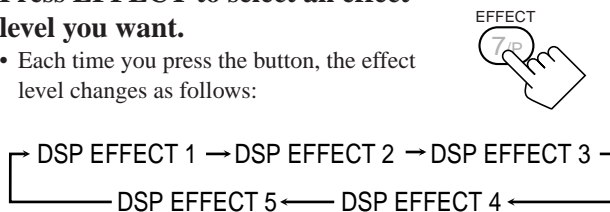

As the number increases, the selected DAP mode becomes stronger.

## Adjusting the Surround Modes

Once you have adjusted the Surround modes, the adjustment is memorized for each Surround mode.

### Dolby, DTS and MPEG Surround adjustments

Before you start, remember...

- Make sure that you have set the speaker information correctly (see page 14).
- There is a time limit in doing the following steps. If the setting is canceled before you finish, start from step 1 again.
- You cannot adjust the rear speaker output levels when you have set "REAR SPK" to "NONE." See page 14.
- You cannot adjust the center speaker output level you have set "CENTER SPK" to "NONE." See page 14.

#### From the remote control:

1. Press SURROUND ON/OFF to activate an appropriate Surround mode — PRO LOGIC, DOLBY DIGITAL, DTS SURROUND or MPEG SURROUND.



- Each time you press the button, the Surround mode turns on and off alternately.
- When "PRO LOGIC" is selected, the PRO LOGIC indicator lights up on the display.

#### Note:

You can also press SURROUND MODE to activate an appropriate Surround mode.

2. Press SOUND.

The 10 keys are activated for sound adjustments.

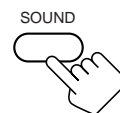

3. Press TEST to check the speaker output balance.

"TEST TONE L" starts flashing on the display, and a test tone comes out of the speakers in the following order:

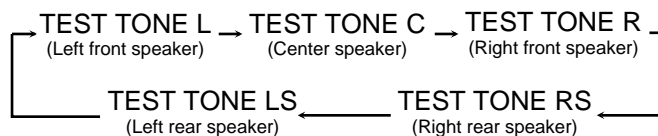
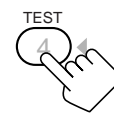

#### Notes:

- You can adjust the speaker output levels without outputting the test tone.
- No test tone comes out of the center speaker when "CENTER SPK" is set to "NONE" (see page 14).
- No test tone comes out of the rear speakers when "REAR SPK" is set to "NONE" (see page 14).
- If the TV is turned on and the proper video input is selected on the TV, the test tone screen will appear on the TV.

#### 4. Adjust the speaker output levels.

- To adjust the center speaker level, press CENTER  $-/+$  (from  $-10$  dB to  $+10$  dB).
- To adjust the left rear speaker level, press REAR•L  $-/+$  (from  $-10$  dB to  $+10$  dB).
- To adjust the right rear speaker level, press REAR•R  $-/+$  (from  $-10$  dB to  $+10$  dB).

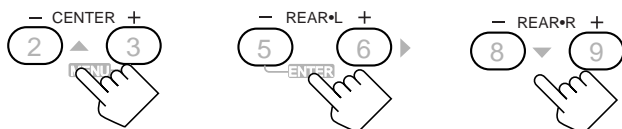

#### 5. Press TEST again to stop the test tone.

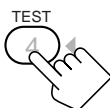

#### On the front panel:

You can also use the buttons on the front panel to adjust the Surround modes. However, no test tone is available when using the buttons on the front panel. So, make adjustments while listening to the sound of the source played back.

#### 1. Press SURROUND ON/OFF to activate an appropriate Surround mode — PRO LOGIC, DOLBY DIGITAL, DTS SURROUND or MPEG SURROUND.



- Each time you press the button, the Surround mode turns on and off alternately.
- When “PRO LOGIC” is selected, the PRO LOGIC indicator lights up on the display.

#### 2. Adjust the speaker output levels.

##### 1) Press (BALANCE/) SURROUND ADJUST repeatedly until one of the indications appears on the display.

“CENTER LEVEL”:

To adjust the center speaker level.

“REAR L LEVEL”:

To adjust the left rear speaker level.

“REAR R LEVEL”:

To adjust the right rear speaker level.

##### 2) Turn MULTI JOG to adjust the selected speaker output level (from $-10$ dB to $+10$ dB).

##### 3) Repeat 1) and 2) to adjust the other speaker output levels.

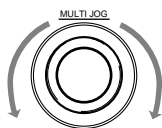

#### JVC Theater Surround adjustments

##### Before you start, remember...

- Make sure that you have set the speaker information correctly (see page 14).
- There is a time limit in doing the following steps. If the setting is canceled before you finish, start from step 1 again.
- You cannot adjust the rear speaker output levels when you have set “REAR SPK” to “NONE.” See page 14.
- You cannot adjust the center speaker output level when you have set “CENTER SPK” to “NONE.” See page 14.

##### From the remote control:

#### 1. Press SURROUND MODE repeatedly until “THEATER” appears on the display.

The PRO LOGIC and DSP indicators also light up on the display.



#### 2. Press SOUND.

The 10 keys are activated for sound adjustments.

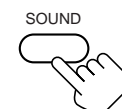

#### 3. Press TEST to check the speaker output balance.

“TEST TONE L” starts flashing on the display, and a test tone comes out of the speakers in the following order:

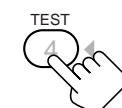
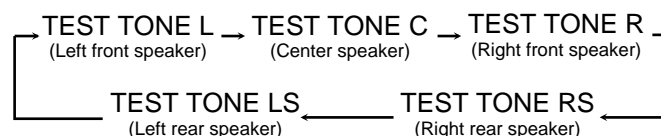

##### Notes:

- You can adjust the speaker output levels without outputting the test tone.
- No test tone comes out of the center speaker when “CENTER SPK” is set to “NONE” (see page 14).
- No test tone comes out of the rear speakers when “REAR SPK” is set to “NONE” (see page 14).
- If the TV is turned on and the proper video input is selected on the TV, the test tone screen will appear on the TV.

#### 4. Adjust the speaker output levels.

- To adjust the center speaker level, press CENTER  $-/+$  (from  $-10$  dB to  $+10$  dB).
- To adjust the left rear speaker level, press REAR•L  $-/+$  (from  $-10$  dB to  $+10$  dB).
- To adjust the right rear speaker level, press REAR•R  $-/+$  (from  $-10$  dB to  $+10$  dB).

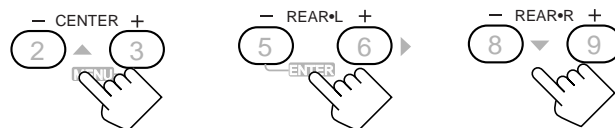



## 5. Press TEST again to stop the test tone.

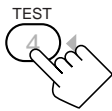

## 6. Press EFFECT to select an effect level you want.

- Each time you press the button, the effect level changes as follows:

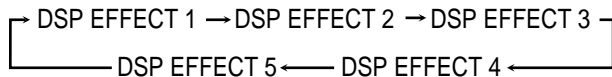

As the number increases, JVC Theater Surround becomes stronger.

### On the front panel:

You can also use the buttons on the front panel to adjust the Surround modes. However, no test tone is available when using the buttons on the front panel. So, make adjustments while listening to the sound of the source played back.

## 1. Press DSP MODE repeatedly until "THEATER" appears on the display.

The PRO LOGIC and DSP indicators also light up on the display.

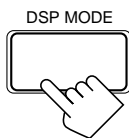

## 2. Adjust the speaker output levels.

### 1) Press (BALANCE/) SURROUND ADJUST repeatedly until one of the indications appears on the display.

"CENTER LEVEL":

To adjust the center speaker level.

"REAR L LEVEL":

To adjust the left rear speaker level.

"REAR R LEVEL":

To adjust the right rear speaker level.

### 2) Turn MULTI JOG to adjust the selected speaker output level (from -10 dB to +10 dB).

### 3) Repeat 1) and 2) to adjust the other speaker output levels.

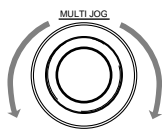

## 3. Adjust the effect level.

### 1) Press (BALANCE/) SURROUND ADJUST repeatedly until "DSP EFFECT" appears on the display.

The display changes to show the current setting.

### 2) Turn MULTI JOG to select the effect level.

As you turn it, the effect level changes as follows:

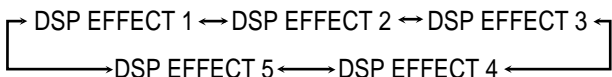
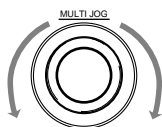

As the number increases, JVC Theater Surround becomes stronger.

## Activating the DSP Modes

You can use only one DSP mode at a time. When a DSP mode is activated, another DSP mode is canceled if in use.

### For Dolby Pro Logic, Dolby Digital, DTS Digital Surround and MPEG Multichannel

## 1. Press SURROUND ON/OFF so that the lamp on the front panel button lights up.

- Each time you press the button, the Dolby/DTS/MPEG Surround turns on and off alternately.



On the front panel



On the remote control

## 2. Select and play a sound source.

- To enjoy Dolby Pro Logic, play back a software encoded with Dolby Surround and labeled with mark.
- To enjoy Dolby Digital, play back a software encoded with Dolby Digital and labeled with mark.
- To enjoy DTS Digital Surround, play back a software encoded with DTS Digital Surround and labeled with mark.
- To enjoy MPEG Multichannel, play back a software encoded with MPEG Multichannel and labeled with mark.

### To cancel the Dolby/DTS/MPEG Surround mode

Press SURROUND ON/OFF again so that the lamp on the front panel button goes off. ("SURROUND OFF" appears on the display.)

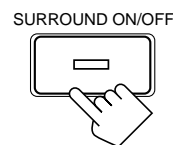

On the front panel



On the remote control



# Using the DVD MULTI Playback Mode

This receiver provides the DVD MULTI playback mode for reproducing the analog discrete output mode of the DVD player. Before playing back a DVD, refer also to the manual supplied with the DVD player.

## IMPORTANT:

When using the remote control, check to see if its remote control mode selector is set to the correct position:

To operate this receiver, set it to "AUDIO/TV/VCR."

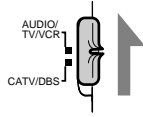

## Activating the DVD MULTI Playback Mode

You can adjust the DVD MULTI playback mode while playing back a DVD using the analog discrete output mode on the DVD player. Once you have made adjustments, the receiver memorizes the adjustments until you change them. You also need to set the DVD player to the analog discrete output mode.

### Before you start, remember...

- There is a time limit in doing the following steps. If the setting is canceled before you finish, start from step 1 again.

### On the front panel:

1. Turn SOURCE SELECTOR until "DVD MULTI" appears on the display.

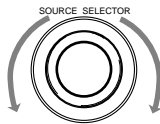

### Note:

When you select "DVD MULTI" as the source to play, the DSP mode is canceled temporarily, and the SURROUND ON/OFF and DSP MODE buttons do not work.

2. Select the analog discrete output mode on the DVD player, and start playing a DVD.

- Refer to the manual supplied with the DVD player.

If you need to make any adjustment, go to the following steps.

3. Adjust the speaker output levels.

- 1) Press (BALANCE/) SURROUND ADJUST repeatedly until one of the indications appears on the display.

"CENTER LEVEL":

To adjust the center speaker level.

"REAR L LEVEL":

To adjust the left rear speaker level.

"REAR R LEVEL":

To adjust the right rear speaker level.

- 2) Turn MULTI JOG to adjust the selected speaker output level (from -10 dB to +10 dB).
- 3) Repeat 1) and 2) to adjust the other speaker output levels.

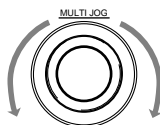

### From the remote control:

1. Press DVD MULTI so that "DVD MULTI" appears on the display.



### Note:

When you select "DVD MULTI" as the source to play, the DSP mode is canceled temporarily, and the SURROUND ON/OFF and SURROUND MODE buttons do not work.

2. Select the analog discrete output mode on the DVD player, and start playing a DVD.

- Refer to the manual supplied with the DVD player.

If you need to make any adjustment, go to the following steps.

3. Press SOUND.

The 10 keys are activated for adjusting the sound.

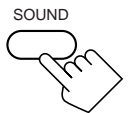

4. Adjust the speaker output levels.

- To adjust the center speaker level, press CENTER +/- (from -10 dB to +10 dB).
- To adjust the left rear speaker level, press REAR•L +/- (from -10 dB to +10 dB).
- To adjust the right rear speaker level, press REAR•R +/- (from -10 dB to +10 dB).

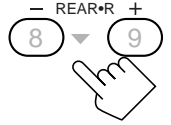
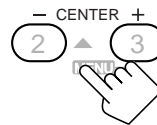

# Using the On-Screen Menus

You can use the Menus on the TV screen to control the receiver.

To use this function, you need to connect the TV to the MONITOR OUT jack on the rear panel (see page 7), and set the TV's input mode to the proper position to which the receiver is connected.

- When the TV's input mode is incorrect; for example, a different video input or TV tuner mode is selected, you cannot show the Menus on the TV screen.

On-Screen Operation buttons (on the remote control)

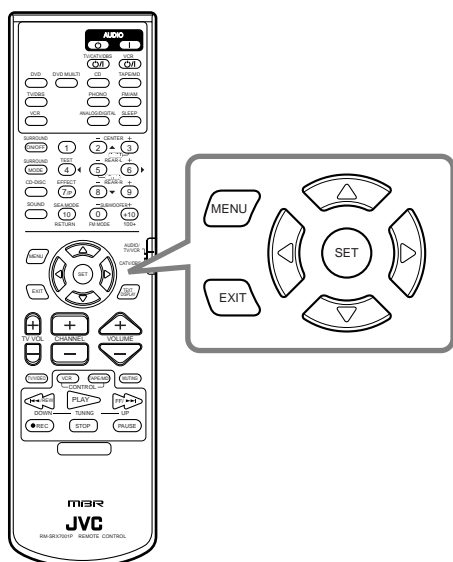

## Selecting Different Sources for Picture and Sound (Also see page 11)

### 1. Press MENU.

The MAIN MENU appears on the TV.

- Pressing one of the  $\Delta$  /  $\nabla$  /  $\triangleleft$  /  $\triangleright$  buttons also displays the MAIN MENU.

### 2. Press $\Delta$ / $\nabla$ to move to "VISUAL."

### 3. Press $\triangleleft$ / $\triangleright$ to select a different video source.

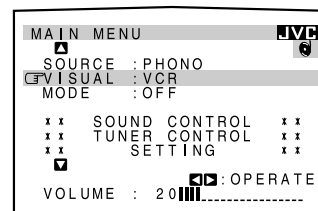

### 4. When you finish, press EXIT.

The menu disappears from the TV.

## Activating the DSP Modes (Also see page 27)

### 1. Press MENU.

The MAIN MENU appears on the TV.

- Pressing one of the  $\Delta$  /  $\nabla$  /  $\triangleleft$  /  $\triangleright$  buttons also displays the MAIN MENU.

### 2. Press $\Delta$ / $\nabla$ to move to "MODE."

### 3. Press $\triangleleft$ / $\triangleright$ to select the DSP mode you want to use.

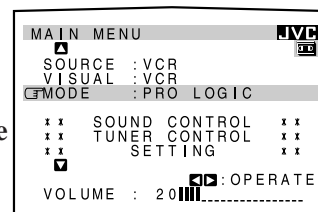

### 4. When you finish, press EXIT.

The menu disappears from the TV.

## Selecting the Source to Play (Also see page 10)

### 1. Press MENU.

The MAIN MENU appears on the TV.

- Pressing one of the  $\Delta$  /  $\nabla$  /  $\triangleleft$  /  $\triangleright$  buttons also displays the MAIN MENU.

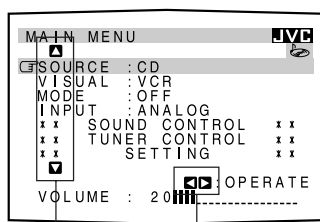

Shows the buttons you can use on the current menu. In this case, use  $\Delta$  /  $\nabla$  to move up and down, and  $\triangleleft$  /  $\triangleright$  to select, adjust or set the item.

#### Notes:

- "INPUT" appears only when the digital input (DIGITAL IN) terminal setting have been correctly done for the digital source currently selected. (See page 16.)
- The on-screen display will disappear if no operation is done for about 1 minute.

### 2. Press $\Delta$ / $\nabla$ to move to "SOURCE."

### 3. Press $\triangleleft$ / $\triangleright$ to select the source.

### 4. When you finish, press EXIT.

The menu disappears from the TV.

## Selecting the Analog or Digital Input Mode (Also see page 16)

This selection is only possible when the digital input (DIGITAL IN) terminal setting have been correctly done for the digital source currently selected.

### 1. Press MENU.

The MAIN MENU appears on the TV.

- Pressing one of the  $\Delta$  /  $\nabla$  /  $\triangleleft$  /  $\triangleright$  buttons also displays the MAIN MENU.

### 2. Press $\Delta$ / $\nabla$ to move to "INPUT."

### 3. Press $\triangleleft$ / $\triangleright$ to select the digital or analog input you want.

For details, see page 16.

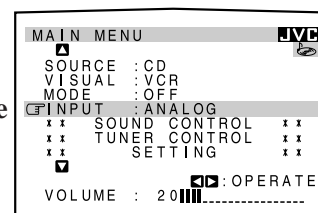

### 4. When you finish, press EXIT.

The menu disappears from the TV.

## ■ Adjusting the Front Speaker Output Balance

(Also see page 13)

### 1. Press MENU.

The MAIN MENU appears on the TV.

- Pressing one of the  $\Delta$  /  $\nabla$  /  $\triangleleft$  /  $\triangleright$  buttons also displays the MAIN MENU.

### 2. Press $\Delta$ / $\nabla$ to move $\leftarrow$ to "SOUND CONTROL," then press $\triangleleft$ / $\triangleright$ .

The SOUND CONTROL menu appears.

### 3. Press $\Delta$ / $\nabla$ to move $\leftarrow$ to "BAL." (Balance).

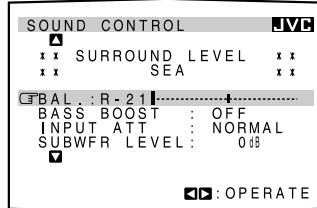

### 4. Press $\triangleleft$ / $\triangleright$ to adjust the balance.

### 5. When you finish, press EXIT repeatedly until the menu disappears from the TV.

## ■ Reinforcing the Bass

(Also see page 12)

### 1. Press MENU.

The MAIN MENU appears on the TV.

- Pressing one of the  $\Delta$  /  $\nabla$  /  $\triangleleft$  /  $\triangleright$  buttons also displays the MAIN MENU.

### 2. Press $\Delta$ / $\nabla$ to move $\leftarrow$ to "SOUND CONTROL," then press $\triangleleft$ / $\triangleright$ .

The SOUND CONTROL menu appears.

### 3. Press $\Delta$ / $\nabla$ to move $\leftarrow$ to "BASS BOOST."

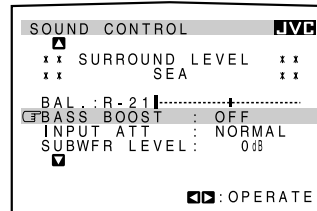

### 4. Press $\triangleleft$ / $\triangleright$ to turn the bass boost function "ON" or "OFF."

### 5. When you finish, press EXIT repeatedly until the menu disappears from the TV.

## ■ Attenuating the Input Signal

(Also see page 12)

### 1. Press MENU.

The MAIN MENU appears on the TV.

- Pressing one of the  $\Delta$  /  $\nabla$  /  $\triangleleft$  /  $\triangleright$  buttons also displays the MAIN MENU.

### 2. Press $\Delta$ / $\nabla$ to move $\leftarrow$ to "SOUND CONTROL," then press $\triangleleft$ / $\triangleright$ .

The SOUND CONTROL menu appears.

### 3. Press $\Delta$ / $\nabla$ to move $\leftarrow$ to "INPUT ATT."

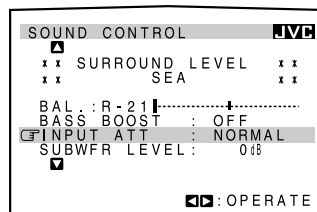

### 4. Press $\triangleleft$ / $\triangleright$ to turn the Input Attenuator mode "ATT ON" or "NORMAL."

### 5. When you finish, press EXIT repeatedly until the menu disappears from the TV.

## ■ Adjusting the Subwoofer Output Level

(Also see page 12)

### 1. Press MENU.

The MAIN MENU appears on the TV.

- Pressing one of the  $\Delta$  /  $\nabla$  /  $\triangleleft$  /  $\triangleright$  buttons also displays the MAIN MENU.

### 2. Press $\Delta$ / $\nabla$ to move $\leftarrow$ to "SOUND CONTROL," then press $\triangleleft$ / $\triangleright$ .

The SOUND CONTROL menu appears.

### 3. Press $\Delta$ / $\nabla$ to move $\leftarrow$ to "SUBWFR LEVEL."

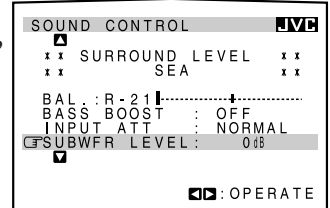

### 4. Press $\triangleleft$ / $\triangleright$ to adjust the subwoofer output level.

### 5. When you finish, press EXIT repeatedly until the menu disappears from the TV.

## ■ Adjusting the DSP Modes

(Also see pages 24 – 27)

### 1. Press MENU.

The MAIN MENU appears on the TV.

- Pressing one of the  $\Delta$  /  $\nabla$  /  $\triangleleft$  /  $\triangleright$  buttons also displays the MAIN MENU.

### 2. Press $\Delta$ / $\nabla$ to move $\leftarrow$ to "MODE."

### 3. Press $\triangleleft$ / $\triangleright$ to select the DSP mode you want to adjust.

- In this example, "THEATER" is selected.

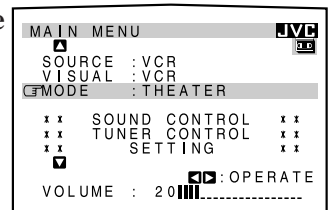

### 4. Press $\Delta$ / $\nabla$ to move $\leftarrow$ to "SOUND CONTROL," then press $\triangleleft$ / $\triangleright$ .

The SOUND CONTROL menu appears.

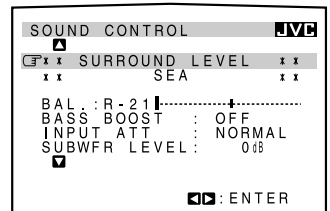

### 5. Press $\Delta$ / $\nabla$ to move $\leftarrow$ to "SURROUND LEVEL," then press $\triangleleft$ / $\triangleright$ .

The SURROUND LEVEL menu appears.

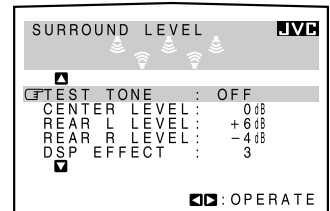

### 6. Press $\Delta$ / $\nabla$ to move $\leftarrow$ to the item you want to set or adjust, then press $\triangleleft$ / $\triangleright$ .

On these adjustment menus, you can do the following:

**For 3D-PHONIC (3D ACTION, 3D THEATER):**

"DSP EFFECT": Select the effect level.

**For DAP (LIVE CLUB, DANCE CLUB, HALL, PAVILION):**

- “REAR L LEVEL”: Adjust the left rear speaker output level. \*
- “REAR R LEVEL”: Adjust the right rear speaker output level. \*
- “DSP EFFECT”: Select the effect level.

**For Dolby Pro Logic:**

- “TEST TONE”: Output a test tone.
- “CENTER LEVEL”: Adjust the center speaker output level. \*\*
- “REAR L LEVEL”: Adjust the left rear speaker output level. \*
- “REAR R LEVEL”: Adjust the right rear speaker output level. \*

**For Dolby Digital, DTS Digital Surround and MPEG Multichannel:**

- “TEST TONE”: Output a test tone.
- “CENTER LEVEL”: Adjust the center speaker output level. \*\*
- “REAR L LEVEL”: Adjust the left rear speaker output level. \*
- “REAR R LEVEL”: Adjust the right rear speaker output level. \*

**For JVC Theater Surround:**

- “TEST TONE”: Output a test tone.
- “CENTER LEVEL”: Adjust the center speaker output level. \*\*
- “REAR L LEVEL”: Adjust the left rear speaker output level. \*
- “REAR R LEVEL”: Adjust the right rear speaker output level. \*
- “DSP EFFECT”: Select the effect level.

**Notes:**

- \* Not displayed when “REAR SPK” is set to “NONE” (see page 14).
- \*\* Not displayed when “CENTER SPK” is set to “NONE” (see page 14).

**7. When you finish, press EXIT repeatedly until the menu disappears from the TV.****■ Adjusting the DVD MULTI Playback Mode**  
(Also see page 29)**1. Press MENU.**

The MAIN MENU appears on the TV.

- Pressing one of the  $\Delta / \nabla / \triangleleft / \triangleright$  buttons also displays the MAIN MENU.

**2. Press  $\Delta / \nabla$  to move  $\square$  to “SOURCE.”****3. Press  $\triangleleft / \triangleright$  to select “DVD MULTI.”****4. Press  $\Delta / \nabla$  to move  $\square$  to “SOUND CONTROL,” then press  $\triangleleft / \triangleright$ .**

The SOUND CONTROL menu appears.

**5. Press  $\Delta / \nabla$  to move  $\square$  to “SURROUND LEVEL,” then press  $\triangleleft / \triangleright$ .**

The SURROUND LEVEL menu appears.

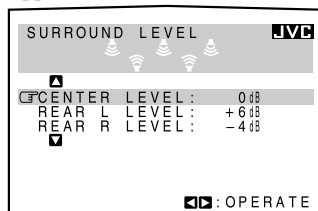
**6. Press  $\Delta / \nabla$  to move  $\square$  to the item you want to set or adjust, then press  $\triangleleft / \triangleright$ .**

On this adjustment menu, you can do the following:

- “CENTER LEVEL”: Adjust the center speaker output level.
- “REAR L LEVEL”: Adjust the left rear speaker output level.
- “REAR R LEVEL”: Adjust the right rear speaker output level.

**7. When you finish, press EXIT repeatedly until the menu disappears from the TV.****■ Selecting Your Favorite SEA Mode**  
(Also see page 20)**1. Press MENU.**

The MAIN MENU appears on the TV.

- Pressing one of the  $\Delta / \nabla / \triangleleft / \triangleright$  buttons also displays the MAIN MENU.

**2. Press  $\Delta / \nabla$  to move  $\square$  to “SOUND CONTROL,” then press  $\triangleleft / \triangleright$ .**

The SOUND CONTROL menu appears.

**3. Press  $\Delta / \nabla$  to move  $\square$  to “SEA,” then press  $\triangleleft / \triangleright$ .**

The SEA menu appears.

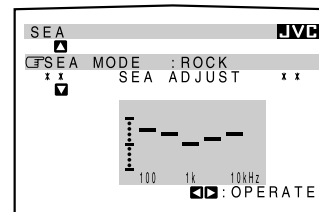
**4. Press  $\Delta / \nabla$  to move  $\square$  to “SEA MODE.”****5. Press  $\triangleleft / \triangleright$  to select the SEA mode you want.****6. When you finish, press EXIT repeatedly until the menu disappears from the TV.****■ Creating Your Own SEA Mode**  
(Also see page 20)**1. Press MENU.**

The MAIN MENU appears on the TV.

- Pressing one of the  $\Delta / \nabla / \triangleleft / \triangleright$  buttons also displays the MAIN MENU.

**2. Press  $\Delta / \nabla$  to move  $\square$  to “SOUND CONTROL,” then press  $\triangleleft / \triangleright$ .**

The SOUND CONTROL menu appears.

**3. Press  $\Delta / \nabla$  to move  $\square$  to “SEA,” then press  $\triangleleft / \triangleright$ .**

The SEA menu appears.



#### 4. Press $\Delta$ / $\nabla$ to move

$\square$  to “SEA ADJUST.”

The SEA ADJUST menu appears.

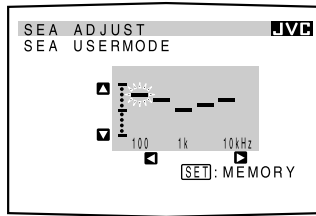

#### 5. Press $\Delta$ / $\nabla$ / $\triangleleft$ / $\triangleright$ to adjust the SEA mode as you want.

$\triangleleft$  /  $\triangleright$  : Select the frequency ranges.

$\Delta$  /  $\nabla$  : Adjust the frequency levels.

#### 6. Press SET to store the setting into the SEA USERMODE.

• If you press EXIT, without pressing SET in this step, you can return to the SEA menu. (The adjustment you have made is active but not stored.)

#### 7. When you finish, press EXIT repeatedly until the menu disappears from the TV.

### Setting the Basic Setting Items (Also see pages 14 – 17)

#### 1. Press MENU.

The MAIN MENU appears on the TV.

• Pressing one of the  $\Delta$  /  $\nabla$  /  $\triangleleft$  /  $\triangleright$  buttons also displays the MAIN MENU.

#### 2. Press $\Delta$ / $\nabla$ to move $\square$ to “SETTING,” then press $\triangleleft$ / $\triangleright$ .

The SETTING 1 or SETTING 2 menu appears.

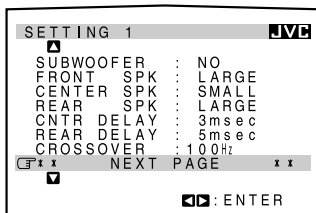

#### 3. Press $\Delta$ / $\nabla$ to move $\square$ to the item you want to set or adjust, then press $\triangleleft$ / $\triangleright$ .

- To go to the SETTING 2 menu, move  $\square$  to “NEXT PAGE,” then press  $\triangleleft$  /  $\triangleright$ .
- To go back to the SETTING 1 menu, move  $\square$  to “PREVIOUS PAGE,” then press  $\triangleleft$  /  $\triangleright$ .

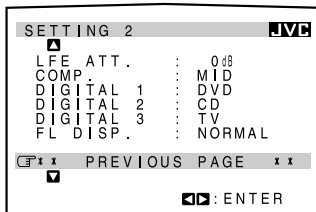

On the SETTING 1 and 2 menus, you can do the following:

- “SUBWOOFER”: Set the subwoofer information (see page 14).
- “FRONT SPK”: Set the front speaker information (see page 14).
- “CENTER SPK”: Set the center speaker information (see page 14).
- “REAR SPK”: Set the rear speaker information (see page 14).
- “CNTR DELAY”: Adjust the delay time of the center speaker output (see page 14).\*
- “REAR DELAY”: Adjust the delay time of the rear speaker output (see page 14).\*\*
- “CROSSOVER”: Set the crossover frequency (see page 15).

- “LFE ATT.”: Set the low frequency effect attenuator level (see page 15).
- “COMP.”: Set the dynamic range compression (see page 15).
- “DIGITAL 1/2/3”:

  - Set the digital input terminals (see page 16).

- “FL DISP.”: Shows the disc text information on the display (see page 17).

#### Notes:

\* Not adjustable when “CENTER SPK” is set to “NONE” (see page 14).

\*\*Not adjustable when “REAR SPK” is set to “NONE” (see page 14).

#### 4. When you finish, press EXIT repeatedly until the menu disappears from the TV.

### Operating the Tuner (Also see pages 18 and 19)

#### 1. Press MENU.

The MAIN MENU appears on the TV.

• Pressing one of the  $\Delta$  /  $\nabla$  /  $\triangleleft$  /  $\triangleright$  buttons also displays the MAIN MENU.

#### 2. Press $\Delta$ / $\nabla$ to move $\square$ to “TUNER CONTROL,” then press $\triangleleft$ / $\triangleright$ .

The TUNER CONTROL menu appears.

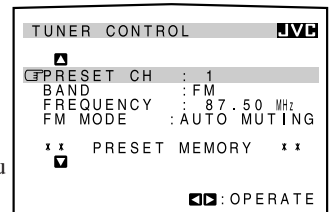

#### 3. Press $\Delta$ / $\nabla$ to move $\square$ to the item you want to set or adjust, then press $\triangleleft$ / $\triangleright$ .

On the TUNER CONTROL menu, you can do the following:

- “PRESET CH”:

  - Select a preset channel station.

- “BAND”:

  - Select the band.

- “FREQUENCY”:

  - Tune in a station manually.

- “FM MODE”:

  - Select the FM reception mode.\*

- “PRESET MEMORY”:

  - See “Storing the Preset Stations” on the next page.

#### Note:

\* Not displayed when an AM station is selected.

#### 4. When you finish, press EXIT repeatedly until the menu disappears from the TV.



## Storing the Preset Stations (Also see page 18)

### 1. Press MENU.

The MAIN MENU appears on the TV.

- Pressing one of the  $\Delta$  /  $\nabla$  /  $\triangleleft$  /  $\triangleright$  buttons also displays the MAIN MENU.

### 2. Press $\Delta$ / $\nabla$ to move $\leftarrow$ to "TUNER CONTROL," then press $\triangleleft$ / $\triangleright$ .

The TUNER CONTROL menu appears.

### 3. Tune into a station on the TUNER CONTROL menu, referring to "Operating the Tuner" on the previous page.

### 4. Press $\Delta$ / $\nabla$ to move $\leftarrow$ to "PRESET MEMORY," then press $\triangleleft$ / $\triangleright$ .

The PRESET MEMORY menu appears.

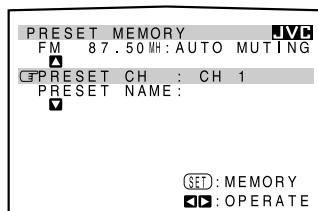

### 5. Press $\triangleleft$ / $\triangleright$ to select a preset station number you want.

### 6. Press SET to store the setting.

### 7. When you finish, press EXIT repeatedly until the menu disappears from the TV.

## Assigning Names to Preset Stations (Also see page 19)

### 1. Press MENU.

The MAIN MENU appears on the TV.

- Pressing one of the  $\Delta$  /  $\nabla$  /  $\triangleleft$  /  $\triangleright$  buttons also displays the MAIN MENU.

### 2. Press $\Delta$ / $\nabla$ to move $\leftarrow$ to "TUNER CONTROL," then press $\triangleleft$ / $\triangleright$ .

The TUNER CONTROL menu appears.

### 3. Press $\Delta$ / $\nabla$ to move $\leftarrow$ to "PRESET CH."

### 4. Press $\triangleleft$ / $\triangleright$ to select a preset station.

### 5. Press $\Delta$ / $\nabla$ to move $\leftarrow$ to "PRESET MEMORY," then press $\triangleleft$ / $\triangleright$ .

The PRESET MEMORY menu appears.

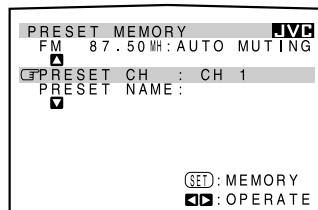

### 6. Press $\Delta$ / $\nabla$ to move $\leftarrow$ to "PRESET NAME," then press SET.

The character entry screen appears.

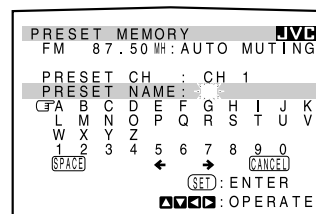

### 7. Press $\Delta$ / $\nabla$ / $\triangleleft$ / $\triangleright$ to move $\leftarrow$ in front of a character you want.

You can also select the following:

- SPACE : To enter space
- CANCEL : To erase the character
- $\triangleleft$  /  $\triangleright$  : To go back to the previous character position or go to the next character position

### 8. Press SET to enter the selected character.

### 9. Repeat steps 7 and 8 to enter up to four characters.

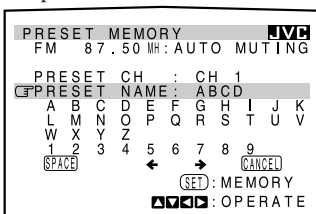

### 10. Press $\Delta$ / $\nabla$ / $\triangleleft$ / $\triangleright$ to move $\leftarrow$ to "PRESET NAME," then press SET to store the setting.

The TUNER CONTROL menu appears again.

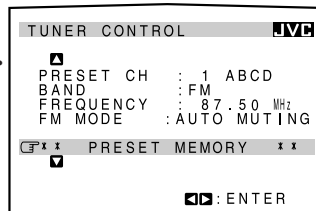

### 11. When you finish, press EXIT repeatedly until the menu disappears from the TV.

# COMPU LINK Remote Control System

The COMPU LINK remote control system allows you to operate JVC audio components through the remote sensor on the receiver.

To use this remote control system, you need to connect JVC audio components through the COMPU LINK-3 (SYNCHRO) jacks (see below) in addition to the connections using cables with RCA pin plugs (see pages 5 and 6).

- Make sure that the AC power cords of these components are unplugged before connection. Plug the AC power cords only after all connections are complete.

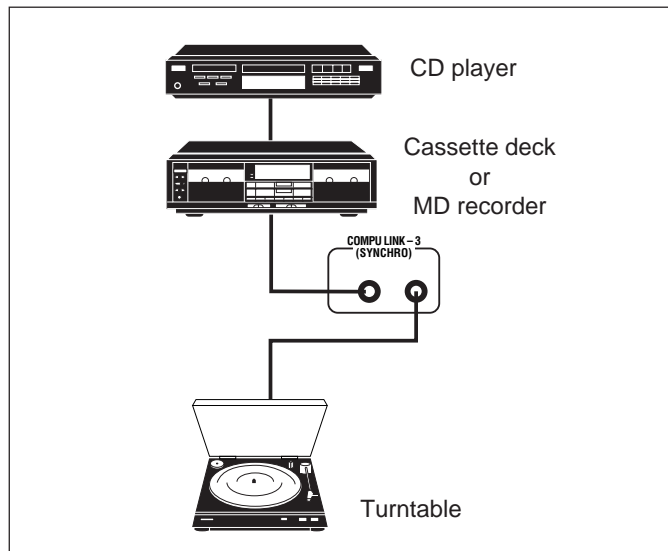

## Notes:

- If your audio component has two COMPU LINK-3 (SYNCHRO) jacks, you can use either one. If it has only one COMPU LINK-3 (SYNCHRO) jack, connect it so that it is the last item in the series of components. (For example, the turntable or CD player in the diagram above.)
- To operate the cassette deck or MD recorder using the COMPU LINK remote control system, set the source name correctly. (See page 13.)
- Refer also to the manuals supplied with your audio components.

This remote control system allows you to use four functions listed below.

## Remote Control through the Remote Sensor on the Receiver

You can control the connected audio components through the remote sensor on the receiver using this remote control. Aim the remote control directly at the remote sensor on the receiver. For details, see pages 43 and 44.

## Automatic Source Selection

When you press the play (▶) button on a connected component or on its own remote control, the receiver automatically turns on and changes the source to the component. On the other hand, if you select a new source on the receiver or on the remote control, the selected component begins playing immediately.

In both cases, the previously selected source continues playing without sound for a few seconds.

## Automatic Power On/Off (Standby): only possible with the COMPU LINK-3 connection

Both the CD player and cassette deck (or MD recorder) turn on and off (standby) along with the receiver.

When you turn on the receiver, the CD player or cassette deck (or MD recorder) will turn on automatically, depending on which component has been previously selected.

When you turn off the receiver, both the CD player and cassette deck (or MD recorder) will turn off (standby).

## Synchronized Recording

Synchronized recording means the cassette deck (or MD recorder) starts recording as soon as a CD or a record begins playing.

To use synchronized recording, follow these steps:

1. Put a tape in the cassette deck (or an MD in the MD recorder), and a disc in the CD player (or a record on the turntable).
2. Press the record (●) button and the pause (||) button on the cassette deck (or MD recorder) at the same time.

This puts the cassette deck (or MD recorder) into recording pause.

If you do not press the record (●) button and pause (||) button at the same time, the synchronized recording feature will not operate.

3. Press the play (▶) button on the CD player or on the turntable.

The source changes on the receiver, and as soon as play starts, the cassette deck (or MD recorder) starts recording. When the play ends, the cassette deck (or MD recorder) enters recording pause, and stops about 4 seconds later.

## Notes:

- During synchronized recording, the selected source cannot be changed.
- If the power of any component is shut off during synchronized recording, the COMPU LINK remote control system may not operate properly. In this case, you must start again from the beginning.

# TEXT COMPU LINK Remote Control System

The TEXT COMPU LINK remote control system has been newly developed to deal with the disc information recorded in the CD Text\* and MDs. Using these information in the discs, you can operate the CD player or MD recorder equipped with the TEXT COMPU LINK remote control system through the receiver.

## CONNECTIONS:

To use this remote control system, you need to connect the CD player and/or MD recorder you want to operate, following the procedures below.

1. If you have already plugged your CD player, MD recorder, and this receiver into the AC outlets, unplug their AC power cords first.
2. Connect your CD player, MD recorder, and this receiver as follows, through the COMPU LINK-3 (SYNCHRO) jacks and TEXT COMPU LINK jacks.

- 1) **COMPU LINK-3 (SYNCHRO) jacks:** Use the cables with the monaural mini-plugs (not supplied with this receiver).

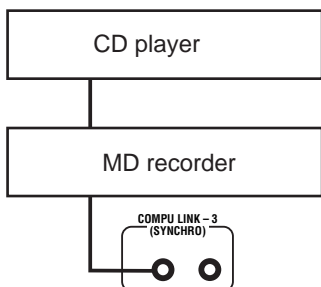

- 2) **TEXT COMPU LINK jacks:** Use the cables with the stereo mini-plugs (not supplied with this receiver).

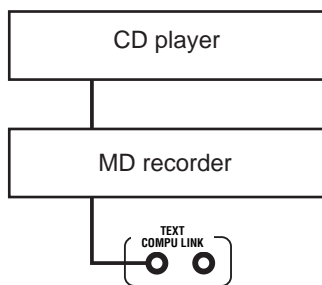

3. Connect your CD player, MD recorder and this receiver, using the cables with RCA pin plugs (see pages 5 and 6).
4. Plug the AC power cords of these components above into the AC outlets.
5. When turning on these components for the first time, turn on the connected components first, then turn on this receiver.

## FUNCTIONS:

This remote control system allows you to use the functions listed below.

### **Displaying the Disc Information on the TV screen**

Disc information such as its performer and disc title (and track titles only when a CD Text is selected) is shown on the TV screen.

### **Disc Search: Only for CD Player**

This remote control system can allow you to search discs by the performer, disc title, and music genre. With this disc search, you can easily find the disc you want to play.

### **Disc Title Input:**

If your CD player or MD recorder has the disc memory function, you can input the following information about the normal audio CDs or MDs on the TV screen.

- For CDs: Performer, disc title, and music genre
- For MDs: Disc title and song titles

### **\*What is a CD Text?**

In a CD Text, some information about the disc (its disc title, performer, composer, arranger, etc.) is recorded.

### **Notes:**

- If your audio component has two COMPU LINK-3 (SYNCHRO) jacks, you can use either one. If it has only one COMPU LINK-3 (SYNCHRO) jack, connect it so that it is the last item in the series of components. (For example, the CD player in the diagram to the left.)
- If your audio component has two TEXT COMPU LINK jacks, you can use either one. If it has only one TEXT COMPU LINK jack, connect it so that it is the last item in the series of components. (For example, the CD player in the diagram to the left.)
- "TEXT COMPULINK SOURCE NOT CONNECTED" appears on the display in the following cases:
  - When the connections explained to the left are not correctly done.
  - When you try to use the TEXT COMPU LINK function a few seconds after you turn on the connected equipment. This is not a malfunction of the units.
- Refer also to the manuals supplied with your CD player or MD recorder.

### **IMPORTANT:**

If you turn on the receiver before turning on the other components after connecting the components, the TEXT COMPU LINK remote control system does not work correctly.

If this happens:

1. Turn off all the components including this receiver.
2. Turn on the connected components.
3. Turn on this receiver.

## OPERATIONS

To use this remote control system, you need to connect the TV to the MONITOR OUT jack on the rear panel (see page 7), and set the TV's input mode to the proper position to which the receiver is connected. **Make sure you have connected the CD player or MD recorder equipped with the TEXT COMPU LINK remote control system. If not, you cannot use the following functions.**

On-Screen Operation buttons (on the remote control)

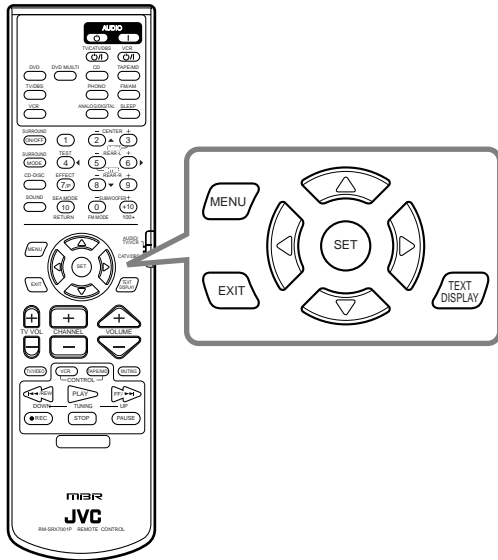

- ① Source name: CD or MD
- ② Select **▲** or **▼**, then press SET to change the disc.
- ③ Track numbers and track titles.
  - The current playing (selected) track is indicated in yellow.
  - When you move **⇐** to a track number, you can change the track information by pressing **◀/▶**. Each time you press the button, track information alternates between its track title and its performer. (You can also start playing the track by pressing SET.)
- ④ Select this (move **⇐** in front), then press SET to go to the DISC SEARCH screen (see page 38).
- ⑤ Select this (move **⇐** in front), then press SET to go to the TITLE INPUT screen (see page 39).
- ⑥ This appears only when a CD Text is selected.
- ⑦ Disc information such as the disc title, performer, and music genre.
  - When this is selected (**⇐** in front), you can change the disc information by pressing **◀/▶**. Each time you press the button, disc information (see “Note on ⑦”) changes.
- ⑧ Select **▲** or **▼**, then press SET to change the track.
- ⑨ Usable buttons and their functions for the current selection.
  - Indication here will be changed according to what is currently selected (**⇐** in front) on the screen. See “Note on ⑨.”

### Note on ⑦:

The following information will appear on the display:

- For CD Texts — Disc title, Performer, Genre, Song writer, Composer, Arranger, Message  
Only recorded information will be shown. If there is no data, “NO DATA” will appear.
- For MDs — Disc title  
If there is no data, “NO DATA” will appear.

### Note on ⑨:

For example, the SET button will be used to start play (PLAY), to go to the next screen (ENTER), and to determine the selection (ENTER).

### To exit from the Disc information screen:

Press EXIT.

### Notes:

- The on-screen display will disappear in the following cases:
  - if no operation is done for about 10 minutes.
  - if you do any operation other than explained in this section.
- To control the MD recorder using the TEXT COMPU LINK remote control system, you have to change the source name shown on the display from “TAPE” to “MD.” (See page 13.)
- Some special characters and marks cannot be displayed correctly.

## Showing the Disc Information on the TV Screen

Press TEXT DISPLAY while “CD” or “MD” is selected as the source.

The Disc Information screen appears on the TV.

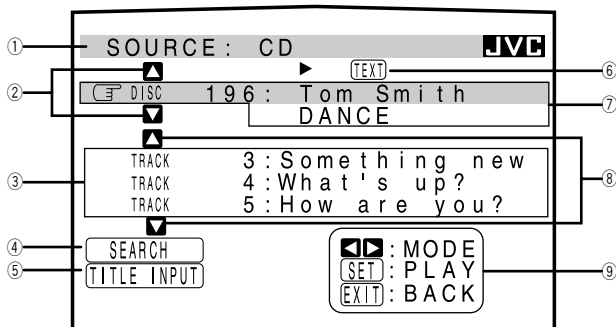

## Searching for a Disc (Only for the CD player)

### Search for a disc by its performer:

1. Press TEXT DISPLAY while "CD" is selected as the source.

The Disc Information screen appears on the TV.

2. Press  $\Delta$  /  $\nabla$  to move  $\leftarrow$  to "SEARCH," then press SET.

The DISC SEARCH screen appears.

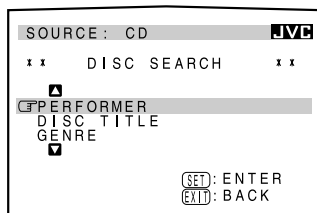

3. Press  $\Delta$  /  $\nabla$  to move  $\leftarrow$  to "PERFORMER", then press SET.

The PERFORMER SEARCH screen appears.

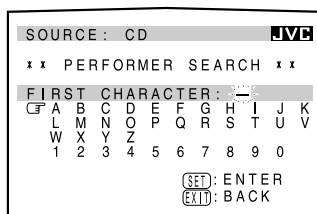

4. Press  $\Delta$  /  $\nabla$  /  $\leftarrow$  /  $\rightarrow$  to move  $\leftarrow$  in front of the first character of the performer you want to search, then press SET.

To correct the incorrect entry, press  $\Delta$  /  $\nabla$  /  $\leftarrow$  /  $\rightarrow$  to move  $\leftarrow$  in front of the correct character, then press SET.

#### Note:

Symbols such as @, # or \$ cannot be available for search.

5. Press SET again.

Disc search starts, then the SEARCH RESULT screen, showing the performers, appears.

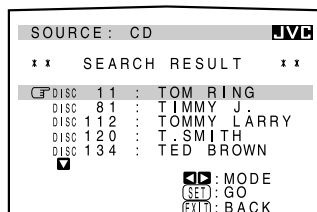

6. On the SEARCH RESULT screen, you can do the following:

- **Changing the indication of the disc information:** Press  $\Delta$  /  $\nabla$  to move  $\leftarrow$  to a searched disc, then press  $\leftarrow$  /  $\rightarrow$ . Each time you press  $\leftarrow$  /  $\rightarrow$ , the disc information alternates between its performer and its disc title.
- **Starting a disc play and going to the Disc Information screen (see page 37):** Press  $\Delta$  /  $\nabla$  to move  $\leftarrow$  to a searched disc, then press SET.
- **Showing unseen disc information (if more than 5 discs are listed as a result of the search):** Press  $\Delta$  /  $\nabla$  until they appear.
- **Going back to the PERFORMER SEARCH screen:** Press EXIT.

### Search for a disc by its disc title:

1. Press TEXT DISPLAY while "CD" is selected as the source.

The Disc Information screen appears on the TV.

2. Press  $\Delta$  /  $\nabla$  to move  $\leftarrow$  to "SEARCH," then press SET.

The DISC SEARCH screen appears.

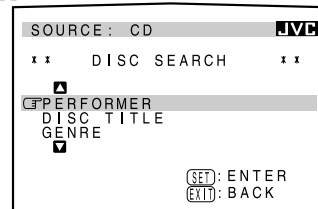

3. Press  $\Delta$  /  $\nabla$  to move  $\leftarrow$  to "DISC TITLE," then press SET.

The DISC TITLE SEARCH screen appears.

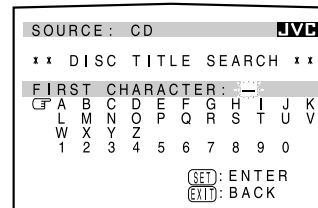

4. Press  $\Delta$  /  $\nabla$  /  $\leftarrow$  /  $\rightarrow$  to move  $\leftarrow$  in front of the first character of the disc title you want to search, then press SET.

To correct the incorrect entry, press  $\Delta$  /  $\nabla$  /  $\leftarrow$  /  $\rightarrow$  to move  $\leftarrow$  in front of the correct character, then press SET.

#### Note:

Symbols such as @, # or \$ cannot be available for search.

5. Press SET again.

Disc search starts, then the SEARCH RESULT screen, showing the disc titles, appears.

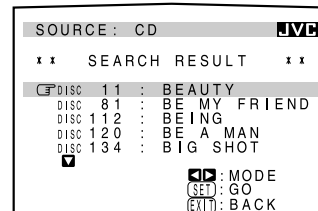

6. On the SEARCH RESULT screen, you can do the following:

- **Changing the indication of the disc information:** Press  $\Delta$  /  $\nabla$  to move  $\leftarrow$  to a searched disc, then press  $\leftarrow$  /  $\rightarrow$ . Each time you press  $\leftarrow$  /  $\rightarrow$ , the disc information alternates between its disc title and its performer.
- **Starting a disc play and going to the Disc Information screen (see page 37):** Press  $\Delta$  /  $\nabla$  to move  $\leftarrow$  to a searched disc, then press SET.
- **Showing unseen disc information (if more than 5 discs are listed as a result of the search):** Press  $\Delta$  /  $\nabla$  until they appear.
- **Going back to the DISC TITLE SEARCH screen:** Press EXIT.



**Search for a disc by its genre:**

1. Press TEXT DISPLAY while “CD” is selected as the source.

The Disc Information screen appears on the TV.

2. Press  $\Delta$  /  $\nabla$  to move  $\leftarrow$  to “SEARCH,” then press SET.

The DISC SEARCH screen appears.

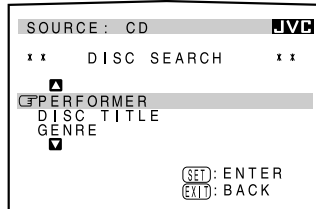

3. Press  $\Delta$  /  $\nabla$  to move  $\leftarrow$  to “GENRE”, then press SET.

The GENRE SEARCH screen appears.

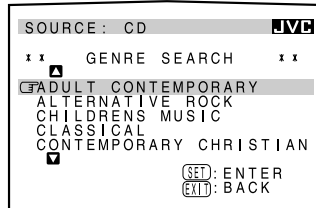

4. Press  $\Delta$  /  $\nabla$  to move  $\leftarrow$  to the genre you want to search, then press SET.

To show the unseen genres, press  $\Delta$  /  $\nabla$  until they appear.

Disc search starts, then the SEARCH RESULT screen, showing the disc titles, appears.

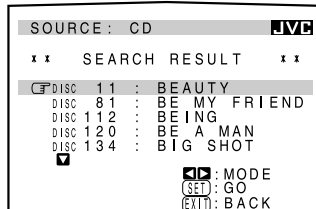

5. On the SEARCH RESULT screen, you can do the following:

- **Changing the indication of the disc information:** Press  $\Delta$  /  $\nabla$  to move  $\leftarrow$  to a searched disc, then press  $\triangleleft$  /  $\triangleright$ . Each time you press  $\triangleleft$  /  $\triangleright$ , the disc information alternates between its disc title and its performer.
- **Starting a disc play and going to the Disc Information screen (see page 37):** Press  $\Delta$  /  $\nabla$  to move  $\leftarrow$  to a searched disc, then press SET.
- **Showing unseen disc information (if more than 5 discs are listed as a result of the search):** Press  $\Delta$  /  $\nabla$  until they appear.
- **Going back to the GENRE SEARCH screen:** Press EXIT.

**Entering the Disc Information****For the CD Player with the disc memory function:**

You can use the disc memory function through this receiver.

The disc information (its performer, disc title, and music genre) of normal audio CDs will be stored into the memory built in the CD player.

For the disc memory function, refer to the manual supplied with your CD player.

- The performer, disc title, and music genre information are usually recorded in a CD Text. However, if a CD Text has no genre information recorded in the disc itself, you can input its music genre by yourself.

**Note:**

You can enter the TITLE INPUT screens for a CD Text and input its titles. However, you cannot store the titles you have input for a CD Text.

**Example: Entering the following information for Disc 1**

Performer: “MICHAEL”

Disc title: “MY FAVORITE”

1. Press TEXT DISPLAY while “CD” is selected as the source.

The Disc Information screen appears on the TV.

2. Press  $\Delta$  /  $\nabla$  to move  $\leftarrow$  to “TITLE INPUT,” then press SET.

The TITLE INPUT:  
PERFORMER screen appears.

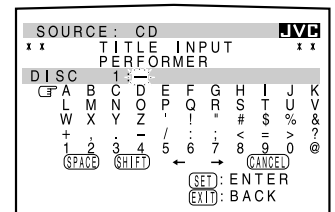

3. Press  $\Delta$  /  $\nabla$  /  $\triangleleft$  /  $\triangleright$  to move  $\leftarrow$  in front of a character you want, then press SET to enter the character.

- If the current CD is a CD Text, go to step 5 without entering the performer.

To use the lower case letters, press  $\Delta$  /  $\nabla$  /  $\triangleleft$  /  $\triangleright$  to move  $\leftarrow$  to (SHIFT), then press SET.

To use the upper case letters again, press  $\Delta$  /  $\nabla$  /  $\triangleleft$  /  $\triangleright$  to move  $\leftarrow$  to (SHIFT), then press SET.

4. Repeat step 3 until you finish putting a performer name (up to 32 characters).

To insert a space, press  $\Delta / \nabla$  /  $\triangleleft / \triangleright$  to move  $\text{C}$  to  $\text{SPACE}$ , then press SET.

To correct an incorrect character:

- 1) Press  $\Delta / \nabla$  /  $\triangleleft / \triangleright$  to move  $\text{C}$  to  $\leftarrow$  or  $\rightarrow$ , then press SET until the incorrect character is selected.
- 2) Press  $\Delta / \nabla$  /  $\triangleleft / \triangleright$  to move  $\text{C}$  to  $\text{CANCELED}$ , then press SET to erase the character.
- 3) Press  $\Delta / \nabla$  /  $\triangleleft / \triangleright$  to move  $\text{C}$  in front of the correct character, then press SET to enter the correct character.

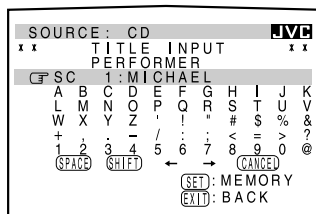

5. Press  $\Delta / \nabla$  /  $\triangleleft / \triangleright$  to move  $\text{C}$  to "DISC 1: MICHAEL (in this example)," then press SET.

The TITLE INPUT: DISC TITLE screen appears.

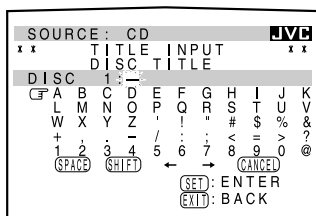

6. Enter the disc title, referring to steps 3 and 4.

- If the current CD is a CD Text, go to the next step without entering the disc title.

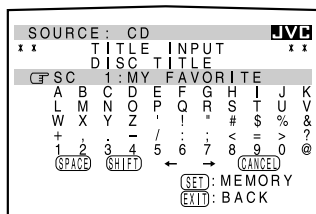

7. Press  $\Delta / \nabla$  /  $\triangleleft / \triangleright$  to move  $\text{C}$  to "DISC 1: MY FAVORITE (in this example)," then press SET.

The TITLE INPUT: DISC 1 GENRE screen appears.

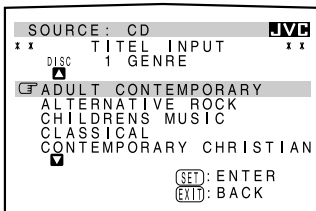

8. Press  $\Delta / \nabla$  to move  $\text{C}$  to the genre you want, then press SET.

The Disc Information screen appears again.

To show the unseen genres, press  $\Delta / \nabla$  until they appear.

### For the MD recorder:

You can write the disc information (disc title and song titles) into the disc. You can only write the song title for the song currently selected.

- If you have the CD-MD combination deck, you can also enter the disc information (its performer, disc title, and its music genre) of normal audio CDs into the memory built in the CD-MD combination deck. (To do this, follow the procedure of "For the CD Player with the disc memory function" on page 39.)
- If you change the disc or song title with more than 32 characters, the characters following 32nd will be erased from the title.

1. Press TEXT DISPLAY while "MD" is selected as the source.

The Disc Information screen appears on the TV.

2. Press  $\Delta / \nabla$  to move  $\text{C}$  to "TITLE INPUT," then press SET.

The DISC TITLE INPUT screen appears.

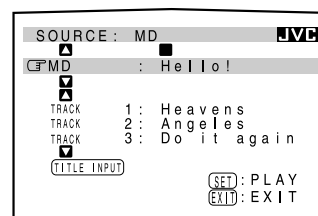

3. Enter the title, referring to steps 3 and 4 of "For the CD Player with the disc memory function" on page 39.

- You can enter up to 32 characters for the disc title.

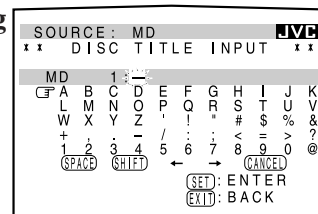

4. Press  $\Delta / \nabla$  /  $\triangleleft / \triangleright$  to move  $\text{C}$  to the disc title you have just entered, then press SET.

The disc title is stored into the memory, and the SONG TITLE INPUT screen for the currently selected song appears.

- You can enter a song title for the song currently selected (indicated in yellow on the TV screen).

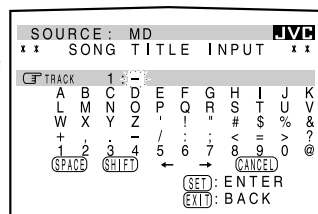

5. Enter the song title, referring to steps 3 and 4 of "For the CD Player with the disc memory function" on page 39.

- You can enter up to 32 characters for the song title.

6. Press  $\Delta / \nabla$  /  $\triangleleft / \triangleright$  to move  $\text{C}$  to the song title you have just entered, then press SET.

The song title is stored into the memory, and the Disc Information screen appears again.

# AV COMPU LINK Remote Control System

The AV COMPU LINK remote control system allows you to operate JVC video components (TV, VCR, and DVD player) through the receiver.

To use this remote control system, you need to connect the video components you want to operate, following the diagrams below and the procedure on the next page.

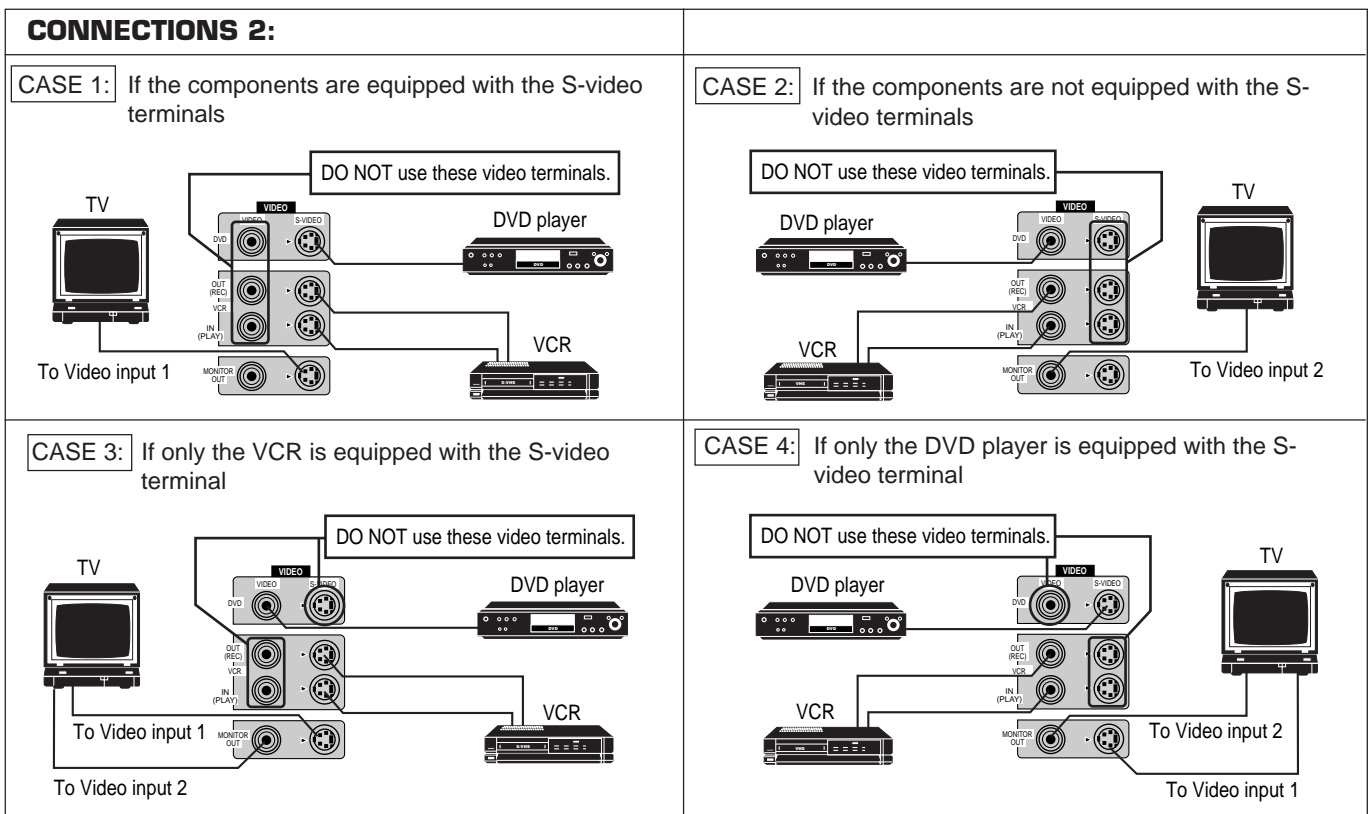
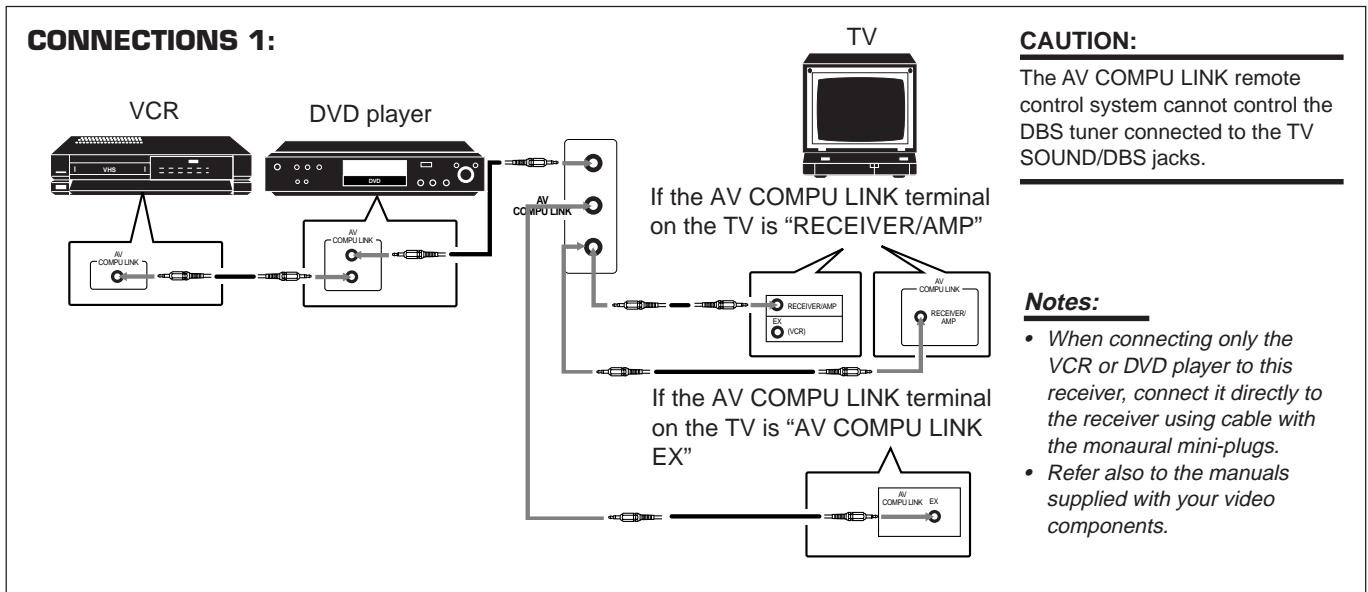

1. **If you have already plugged your VCR, DVD player, TV, and this receiver into the AC outlets, unplug their AC power cords first.**
2. **Connect your VCR, DVD player, TV, and this receiver, using the cables with the monaural mini-plugs (not supplied).**
  - See "CONNECTIONS 1" on the previous page.
3. **Connect the audio input/output jacks on VCR, DVD player, TV, and this receiver using the cables with RCA pin plug.**
  - See pages 6 and 7.
4. **Connect the video input/output jacks on VCR, DVD player, TV, and this receiver, using the cables with RCA pin plug or with S-video plug.**
  - See "CONNECTIONS 2" on the previous page.
5. **Plug the AC power cords of the components into the AC outlets.**
6. **When turning on the TV for the first time after the AV COMPU LINK connection, turn the TV volume to the minimum using the TV volume control on the TV.**
7. **Turn on the other connected components first, then turn on this receiver.**
  - When turning on the VCR, use the remote control supplied with this receiver (press VCR  $\odot$ /1).

The AV COMPU LINK remote control system allows you to use the five basic functions listed below.

#### **Remote Control of the TV, DVD player, and VCR Using This Remote Control**

See page 45 for details.

##### **For the DVD player and the VCR:**

- Aim the remote control directly at **the remote sensor on each component.**

##### **For the TV having AV COMPU LINK terminal "RECEIVER/AMP":**

- Aim the remote control directly at **the remote sensor on the receiver.**

##### **For the TV having AV COMPU LINK terminal "AV COMPU LINK EX":**

- Aim the remote control directly at **the remote sensor on the TV.**

#### **One-Touch Video Play**

Simply by inserting a video cassette without its safety tab into the VCR, you can enjoy the video playback without setting other switches manually. The receiver automatically turns on and changes the source to "VCR."

The TV automatically turns on and changes the input mode to the position so that you can view the playback picture.

When you insert a video cassette with its safety tab, press the play ( $\blacktriangleright$ ) button on the VCR or on the remote control. So, you can get the same result.

#### **One-Touch DVD Play**

Simply by starting playback on the DVD player, you can enjoy the DVD playback without setting other switches manually.

- When the DVD player is connected through the analog input jacks on this receiver (and analog input is selected), the receiver automatically turns on and changes the source to "DVD" or "DVD MULTI."
- When the DVD player is connected through the digital input terminal on this receiver (and digital input is selected), the receiver automatically turns on and changes the source to "DVD DIGITAL."

The TV automatically turns on and changes the input mode to the position so that you can view the playback picture.

#### **Automatic Selection of TV's Input Mode**

- When you select "TV SOUND" (or "TV DIGITAL") as the source to play on the receiver, the TV automatically changes the input mode to the TV tuner so that you can watch TV.
- When you select "DVD" (or "DVD DIGITAL"), "DVD MULTI," "VCR," or "DBS" (or "DBS DIGITAL") as the source to play on the receiver, the TV automatically changes the input mode to the appropriate position (either Video Input 1 or Video Input 2) so that you can view the playback picture.

#### **Note:**

When you select "TV SOUND" (or "TV DIGITAL") as the source on the receiver, you cannot see the menu on the TV screen since the AV COMPU LINK remote control system automatically changes the TV's input mode to the TV tuner.

If you do not mind stopping listening to the TV sounds, you can then show the on-screen displays after changing the TV's input mode to the appropriate position (either Video Input 1 or Video Input 2) the receiver is connected to.

#### **Automatic Power On/Off**

The TV, VCR, and DVD player turn on and off along with the receiver.

When you turn on the receiver;

- If the previously selected source is "VCR," the TV and VCR will turn on automatically.
- If the previously selected source is "TV SOUND" (or "TV DIGITAL") or "DBS" (or "DBS DIGITAL"), only the TV will turn on automatically.
- If the previously selected source is "DVD" (or "DVD DIGITAL") or "DVD MULTI," the TV and DVD player will turn on automatically.

When you turn off the receiver, the TV, VCR and the DVD player will turn off.

#### **Note:**

If you turn off the receiver while recording on the VCR, the VCR will not turn off, but continue recording.

# Operating JVC's Audio/Video Components

You can operate JVC's audio and video components with this receiver's remote control, since control signals for JVC components are preset in the remote control.

## Operating Audio Components

### IMPORTANT:

To operate JVC's audio components using this remote control:

- You need to connect JVC audio components through the COMPU LINK-3 (SYNCHRO) jacks (see page 35) in addition to the connections using cables with RCA pin plugs (see pages 5 and 6).
- Aim the remote control directly at the remote sensor on the receiver.
- If you use the buttons on the front panel or the menu function to choose a source, the remote control will not operate that source. To operate a source with the remote control, the source must be selected using source selecting buttons on the remote control.
- To operate the cassette deck or MD recorder using the COMPU LINK remote control system, set the source name correctly. (See page 13.)
- Refer also to the manuals supplied with your components.

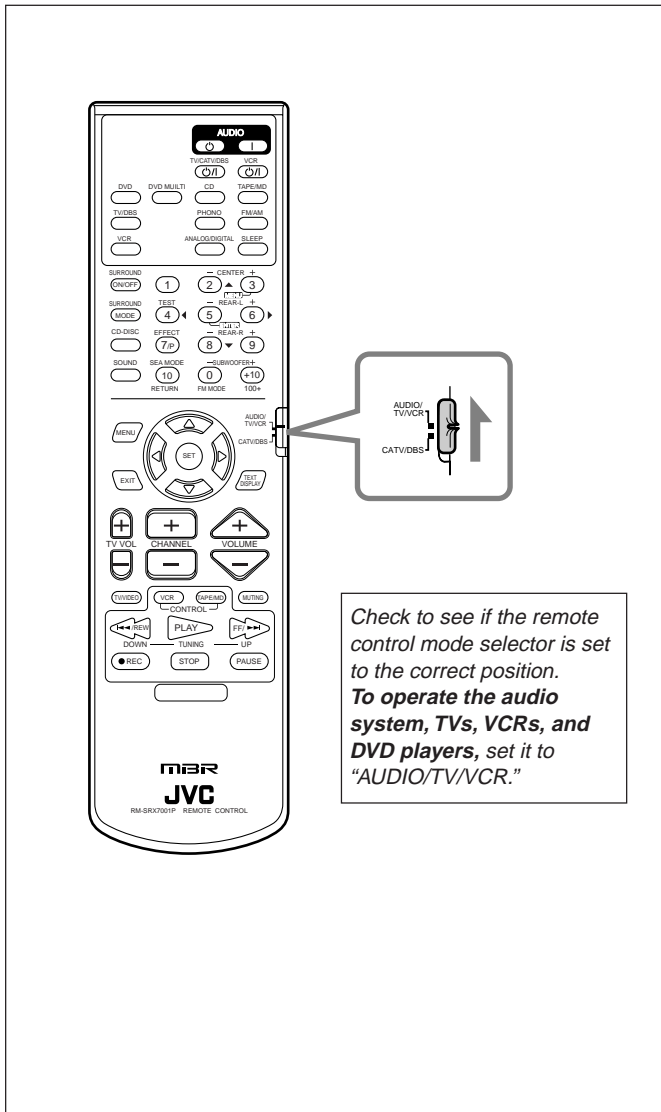

### Tuner

You can always perform the following operations (with the remote control mode selector set to "AUDIO/TV/VCR"):

FM/AM: Alternates between FM and AM.

After pressing FM/AM (with the remote control mode selector set to "AUDIO/TV/VCR"), you can perform the following operations:

- 1 – 10, +10: Selects a preset channel number directly.  
 For channel number 5, press 5.  
 For channel number 15, press +10, then 5.  
 For channel number 20, press +10, then 10.

### TUNING UP/TUNING DOWN:

Tunes into stations.

FM MODE: Changes the FM reception mode.

### Sound control section (Amplifier)

You can always perform the following operations (with the remote control mode selector set to "AUDIO/TV/VCR"):

SURROUND ON/OFF: Turns on or off the Surround modes — Dolby Pro Logic, Dolby Digital, DTS Digital Surround and MPEG Multichannel.

SURROUND MODE: Selects the DSP modes.

After pressing SOUND (with the remote control mode selector set to "AUDIO/TV/VCR"), you can perform the following operations:

- SEA MODE: Changes the SEA modes.  
 SUBWOOFER – / +: Adjusts the subwoofer output level.  
 CENTER – / +: Adjusts the center speaker output level.  
 REAR•L – / +: Adjusts the left rear speaker output level.  
 REAR•R – / +: Adjusts the right rear speaker output level.  
 EFFECT: Selects the effect level.  
 TEST: Turns on or off the test tone output.

### Note:

After adjusting sounds, press the corresponding source selecting button or CD-DISC to operate your target source by using the 10 keys; otherwise, the 10 keys cannot be used for operating your target source.

### CD player

After pressing CD (with the remote control mode selector set to "AUDIO/TV/VCR"), you can perform the following operations on the CD player:

- PLAY: Starts playing.  
 ⏮: Returns to the beginning of the current (or previous) track.  
 ⏭: Skips to the beginning of the next track.  
 STOP: Stops playing.  
 PAUSE: Pauses playing. To release it, press PLAY.  
 1 – 10, +10: Selects a track number directly.  
 For track number 5, press 5.  
 For track number 15, press +10, then 5.  
 For track number 20, press +10, then 10.  
 For track number 30, press +10, +10, then 10.



**CD player-changer**

After pressing CD-DISC (with the remote control mode selector set to "AUDIO/TV/VCR"), you can perform the following operations on a CD player-changer:

PLAY:	Starts playing.
◀◀:	Returns to the beginning of the current (or previous) track.
▶▶:	Skips to the beginning of the next track.
STOP:	Stops playing.
PAUSE:	Pauses playing. To release it, press PLAY.
1 – 6, 7/P:	Selects the number of a disc installed in a CD player-changer.

After pressing CD (with the remote control mode selector set to "AUDIO/TV/VCR"), you can perform the following operations on the CD player-changer:

1 – 10, +10:	Selects a track number directly. For track number 5, press 5. For track number 15, press +10, then 5. For track number 20, press +10, then 10. For track number 30, press +10, +10, then 10.
--------------	--

**Turntable**

After pressing PHONO (with the remote control mode selector set to "AUDIO/TV/VCR"), you can perform the following operations on a turntable:

PLAY:	Starts playing.
STOP:	Stops operations.

**Cassette deck**

After pressing TAPE/MD or TAPE/MD CONTROL (with the remote control mode selector set to "AUDIO/TV/VCR"), you can perform the following operations on a cassette deck:

PLAY:	Starts playing.
◀◀:	Fast winds the tape from right to left.
▶▶:	Fast winds the tape from left to right.
STOP:	Stops operations.
PAUSE:	Pauses playing. To release it, press PLAY.
● REC:	Press this button with the PLAY button to start recording. Press this button with the PAUSE button to enter recording pause.

**MD recorder**

After pressing TAPE/MD or TAPE/MD CONTROL (with the remote control mode selector set to "AUDIO/TV/VCR"), you can perform the following operations on the MD recorder:

PLAY:	Starts playing.
◀◀:	Returns to the beginning of the current (or previous) track.
▶▶:	Skips to the beginning of the next track.
STOP:	Stops playing.
PAUSE:	Pauses playing. To release it, press PLAY.
● REC:	Press this button with the PLAY button to start recording. Press this button with the PAUSE button to enter recording pause.

**Note:**

*You can use either TAPE/MD button or the TAPE/MD CONTROL button to activate the buttons listed above. If you press TAPE/MD, the playing source also changes. On the other hand, if you press TAPE/MD CONTROL, the playing source does not change.*

## Operating Video Components

### IMPORTANT:

To operate JVC's video components using this remote control:

- You need to connect JVC video components through the AV COMPU LINK terminals (see page 41) in addition to the connections using cables with RCA pin plugs (see pages 6 and 7).
- Some JVC VCRs can accept two types of the control signals — remote code “A” and “B.” Before using this remote control, make sure that the remote control code of the VCR is set to code “A.”
- When using the remote control:
  - For the DVD player and VCR operations, aim the remote control directly at the remote sensor on each component, not on the receiver.
  - For the TV operations:
    - If the TV has the AV COMPU LINK terminal “RECEIVER/AMP,” aim the remote control directly at the remote sensor on the receiver.
    - If the TV has the AV COMPU LINK terminal “AV COMPU LINK EX,” aim the remote control directly at the remote sensor on the TV.

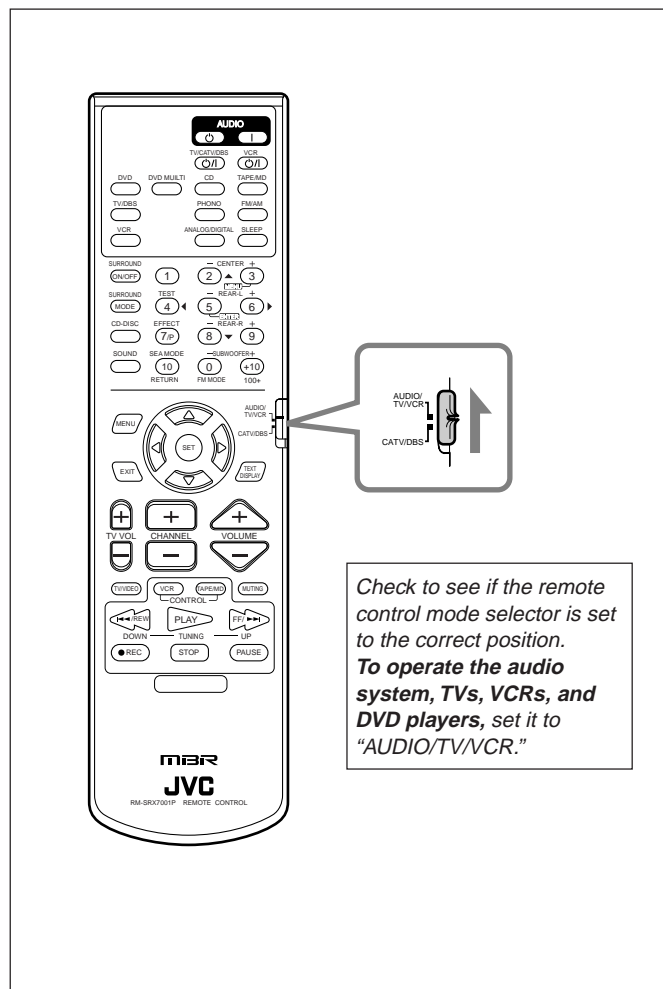

### VCR

You can always perform the following operations (with the remote control mode selector set to “AUDIO/TV/VCR”):

VCR  $\odot/|$ : Turns on or off the VCR.

After pressing VCR or VCR CONTROL (with the remote control mode selector set to “AUDIO/TV/VCR”), you can perform the following operations on the VCR:

- 1 – 9, 0: Selects the TV channels on VCR.
- PLAY: Starts playing.
- ◀◀: Rewinds a tape.
- ▶▶: Fast winds a tape.
- STOP: Stops operations.
- PAUSE: Pauses playing. To release it, press PLAY.
- REC: Press this button with the PLAY button to start recording. Press this button with the PAUSE button to enter recording pause.

CHANNEL +/-: Changes the TV channels on the VCR.

### Note:

You can use either VCR button or the VCR CONTROL button to activate the buttons listed above. If you press VCR, the playing source also changes. On the other hand, if you press VCR CONTROL, the playing source does not change.

### DVD player

After pressing DVD or DVD MULTI (with the remote control mode selector set to “AUDIO/TV/VCR”), you can perform the following operations on a DVD player:

- PLAY: Starts playing.
- ◀◀: Returns to the beginning of the current (or previous) track.
- ▶▶: Skips to the beginning of the next track.
- STOP: Stops playing.
- PAUSE: Stops playing temporarily. To release it, press PLAY.

After pressing DVD or DVD MULTI, these buttons can be used for the DVD menu operations.

### Note:

For detailed menu operations, refer to the instructions supplied with the discs or the DVD player.

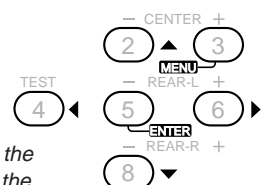

### TV

You can always perform the following operations (with the remote control mode selector set to “AUDIO/TV/VCR”):

- TV/CATV/DBS  $\odot/|$ : Turns on or off the TV.
- TV VOL +/-: Adjusts the volume.
- TV/VIDEO: Sets the input mode (either TV or VIDEO).

After pressing TV/DBS (with the remote control mode selector set to “AUDIO/TV/VCR”), you can perform the following operations on a TV:

- CHANNEL +/-: Changes the channels.
- 1 – 9, 0, 100+: Selects the channels.
- RETURN: Alternates between the previously selected channel and the current channel.

This remote control supplied with the receiver can transmit control signals for other manufacturers' VCRs, TVs, CATV converters and DBS tuners. By changing the transmittable signals from preset ones to the other manufacturers', you can operate the other manufacturer's components using this remote control.

When operating the other manufacturers' components, refer also to the manuals supplied with them. To operate these components with the remote control, first you need to set the manufacturer's code each for VCR, TV, CATV converters and DBS tuners.

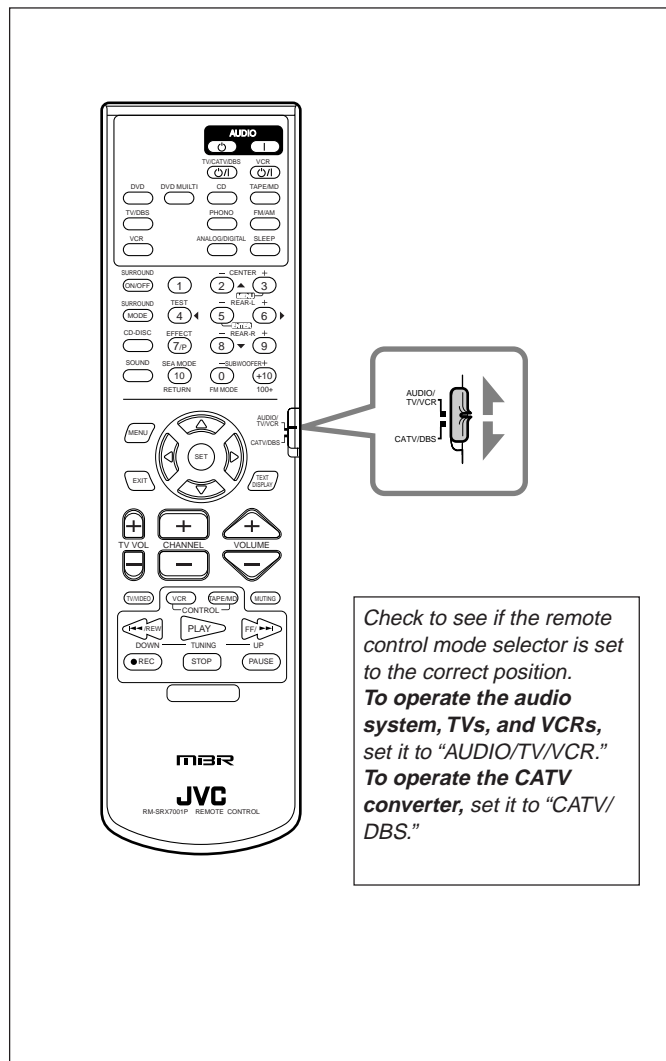

## To change the transmittable signals for operating another manufacturer's TV

1. Set the remote control mode to "AUDIO/TV/VCR."
2. Press and hold TV/CATV/DBS  $\odot/|$ .
3. Press TV/DBS.
4. Enter manufacturer's code (three digits) using buttons 1 – 9, and 0.

See the list on pages 48 and 49 to find the code.

Examples: For a JVC product, press 0, 3, then 6.

For a Sony product, press 0, 0, then 0.

5. Release TV/CATV/DBS  $\odot/|$ .

The following buttons can be used for operating the TV (with the remote control mode selector set to "AUDIO/TV/VCR"):

TV/CATV/DBS  $\odot/|$ : Turns on and off the TV.

TV VOL +/-: Adjusts the volume.

TV/VIDEO: Sets the input mode (either TV or VIDEO).

After pressing TV/DBS (with the remote control mode selector set to "AUDIO/TV/VCR"), you can perform the following operations on a TV:

CHANNEL +/-: Changes the channels.

1 – 10, 0, 100+ (+10): Selects the channels.

The 100+ (+10) button will function as the ENTER button if your TV requires pressing ENTER after selecting a channel number.

### Note:

Refer to the manual supplied with your TV.

6. Try to operate your TV by pressing TV/CATV/DBS  $\odot/|$ .

When your TV turns on or off, you have entered the correct code.

If there are more than one code listed for your brand of TV, try each one until the correct one is entered.

## To change the transmittable signals for operating a CATV converter or DBS tuner

1. Set the remote control mode to "CATV/DBS."
2. Press and hold TV/CATV/DBS  $\odot/|$ .
3. Press TV/DBS.
4. Enter manufacturer's code (three digits) using buttons 1 – 9, and 0.

See the list on pages 49 and 50 to find the code.

Examples: For a Toshiba product, press 0, 0, then 0.  
For a Samsung product, press 7, 0, then 2.

### 5. Release TV/CATV/DBS $\odot/|$ .

After setting the remote control mode selector to "CATV/DBS," you can perform the following operations on the CATV converter or on the DBS tuner:

TV/CATV/DBS $\odot/ $ :	Turns on and off the CATV converter or the DBS tuner.
CHANNEL +/-:	Changes the channels.
1 – 10, 0, 100+ (+10):	Selects the channels. The 100+ (+10) button will function as the ENTER button if your equipment requires pressing ENTER after selecting a channel number.

#### **Note:**

Refer to the manual supplied with your CATV converter or DBS tuner.

### 6. Try to operate your CATV converter or DBS tuner by pressing TV/CATV/DBS $\odot/|$ .

When your CATV converter or DBS tuner turns on or off, you have entered the correct code.

**If there are more than one code listed for your brand of CATV converter or DBS tuner,** try each one until the correct one is entered.

## To change the transmittable signals for operating another manufacturer's VCR

1. Set the remote control mode to "AUDIO/TV/VCR."
2. Press and hold VCR  $\odot/|$ .
3. Press VCR.
4. Enter manufacturer's code (three digits) using buttons 1 – 9, and 0.

See the list on pages 50 and 51 to find the code.

Examples: For a JVC product, press 0, 0, then 8.  
For an NEC product, press 0, 3, then 8.

### 5. Release VCR $\odot/|$ .

The following button can be used for operating the VCR (with the remote control mode selector set to "AUDIO/TV/VCR"):

VCR  $\odot/|$ : Turns on and off the VCR.

After pressing VCR or VCR CONTROL (with the remote control mode selector set to "AUDIO/TV/VCR"), you can perform the following operations on the VCR:

CHANNEL +/-:	Changes the TV channels on the VCR.
1 – 10, 0, 100+ (+10):	Selects the TV channels. The 100+ (+10) button will function as the ENTER button if your VCR requires pressing ENTER after selecting a channel number.
PLAY:	Starts playback.
◀◀:	Rewinds a video tape.
▶▶:	Fast winds a video tape.
STOP:	Stops operation.
PAUSE:	Pauses.
● REC:	Starts recording or enters recording pause.

#### **Notes:**

- Refer to the manual supplied with your VCR.
- You can use either VCR button or the VCR CONTROL button to activate the buttons listed above. If you press VCR, the playing source also changes. On the other hand, if you press VCR CONTROL, the playing source does not change.

### 6. Try to operate your VCR by pressing VCR $\odot/|$ .

When your VCR turns on or off, you have entered the correct code.

**If there are more than one code listed for your brand of VCR,** try each one until the correct one is entered.

**Manufacturers' codes for TV**

A-Mark	003	Finlux	037
Acura	009	Firstline	009, 216
Admiral	093	Fisher	154, 208
Aiko	092	Formenti	037
Akai	030, 208	Fortress	093
Akura	264	Frontech	264
Alaron	216	Funai	264, 342
Alba	009, 036, 037	GE	047, 093, 178, 451
Amstrad	009, 037	GEC	037
Anam	003, 004, 009, 068, 161, 250, 425, 426	Geloso	009
Anam National	161, 250, 425	General	186
Anitech	009, 068	Gibraltar	030
AOC	003, 030	GoldStar	001, 002, 030, 037, 039, 178, 283, 409, 457, 467
Arcam	216	Goodmans	036, 037
Archer	003	Gradiente	053, 170
Audinac	391	Granada	037, 208, 502
Audiosonic	037	Grundig	037, 535, 554
Audiovox	003, 092, 451	Hallmark	178
Basic Line	009	Hanseatic	037
Baur	037, 535, 554	Harman/Kardon	054
Bell & Howell	154	Harvard	068
Beon	037	HCM	009
Blaupunkt	535, 554	Hinari	009, 036, 037, 283
Britannia	216	Hitachi	036, 145, 409, 576
Broksonic	003, 426	Huanyu	216
Bush	009, 036, 037	Hypson	037, 264
Candle	030, 186	ICE	264
Carnivale	030	Indiana	037
Carrefour	036	Infinity	054
Carver	054, 170	Inkel	571
Cascade	009	Interbuy	068
Cathay	037	Interfunk	037
CCE	037	Intervision	037, 068, 264
Celebrity	000	ITT	283
Centurion	037	JBL	054
Cimline	009	JCB	000
Cineral	092, 451	JEC	502
Citizen	030, 039, 060, 092, 186	JVC	036, 053, 069, 160
Clarivox	037	Kaisui	009, 216
Contec	009, 036, 216	Kamp	216
Continental Edison	489	Kawasho	216
Craig	161	Kendo	037
Crosley	054	Kenwood	030
Crown	009, 037, 039	Kingsley	216
CS Electronics	216	Korpel	037
Curtis Mathes	030, 039, 047, 054, 060, 093, 145, 154, 166, 451	Koyoda	009
Daewoo	009, 037, 039, 066, 092, 154, 391, 402, 451	KTV	030, 039
Dansai	037	Leyco	037, 264
Dayton	009	Liesenk & Tter	037
De Graaf	208	Logik	001
Decca	037	LXI	047, 054, 154, 156, 178
Denon	145	M Electronic	009, 037, 068
Dixi	004, 009, 037	Magnavox	030, 036, 054, 186
ECE	037	Manesth	264
Ectec	391	Marantz	030, 037, 054
Electroband	000	Mark	037
Electrohome	409	Maruman	391
Elin	037	Matsui	009, 036, 037, 208
Elta	009	Matsushita	250
Emerson	039, 154, 178	Mediator	037
Envision	030	Megatron	003, 145, 178
Erres	037	Memorex	009, 150, 154, 178, 250
Etron	009, 283	Metz	535
Ferguson	037, 560	MGA	030, 150, 178
Fidelity	216	Midland	039, 047
Finlandia	208	Minerva	535, 554
		Mitsubishi	036, 093, 150, 178, 535



Mivar	216
Motorola	093
MTC	030, 060, 216
Multitech	009, 216
NAD	156, 166, 178
National	226
NEC	030, 036, 170
Neckermann	037, 554
NEI	037
Nicamagic	216
Nikkai	037, 216, 264
Nikko	030, 092, 178
Nisato	391
Nordmende	560
NTC	092
Optimus	154, 166, 250
Optonica	093
Orion	037
Osaki	264
Otto Versand	036, 037, 535, 554
Panama	264
Panasonic	161, 226, 250
Pathe Cinema	216
Pausa	009
Penney	002, 003, 030, 039, 047, 060, 156, 178
Philco	030, 054, 145
Philips	037, 054, 554
Phonola	037
Pilot	030, 039
Pioneer	166
Portland	039, 092
Profex	009
Proscan	047
Protech	009, 037, 264
Proton	003, 178
Quasar	250
Quelle	037, 252, 535, 554
Questa	036
R-Line	037
Radio Shack	030, 039, 047, 154, 178, 409
Radiola	037
Rank Arena	036
RCA	047, 090, 093
Realistic	030, 039, 154, 178
Revox	037
Rex	264
Rhapsody	216
Roadstar	009, 264
Runco	030
Saisho	009, 264
Sampo	030, 039
Samsung	009, 030, 037, 039, 060, 090, 178, 264, 427
Samsux	039
Sandra	216
Sansei	451
Sanyo	036, 154, 208, 376, 424
SBR	037
Schneider	037
Scotch	178
Scott	178
Sears	047, 054, 154, 156, 178
SEG	036, 264
Semp	156
Sentra	283
Sharp	036, 039, 093, 256
Siemens	037, 535, 554
Silver	036

Simpson	186
Sky-Worth	037
Sonitron	208
Sonoko	009, 037
Sonolor	208
Sontec	037
Sony	000, 036
Soundesign	178, 186
Soundwave	037
Spectricon	003
Standard	009
SuperTech	216
Supreme	000
Sylvania	030, 054
Sysline	037
Tandy	093
Tashiko	036
Tatung	003, 037
Technics	250
Techwood	003
Teknika	039, 054, 060, 092, 150, 186
Telefunken	252
Teletch	009
Teleton	186
Texet	216
Thomson	489, 560
Thorn	037, 535
TMK	178
Toshiba	036, 060, 154, 156, 241, 502
Totevision	039
Ultra	391
Universum	037, 264, 535
Vector Research	030
Vestel	037
Victor	036, 053, 160, 250, 376
Vidikron	054
Vidtech	036, 178
Wards	030, 054, 178
Watson	037
Wega	036
White Westinghouse	037, 216
Yamaha	030
Yoko	037, 264
Zenith	092
Zonda	003

### Manufacturers' codes for CATV converters

ABC	008
Daeryung	008
GoldStar	838
LG Alps	779
Memorex	000
Now	776
Panasonic	000
Paragon	000
Pulsar	000
Quasar	000
Runco	000
Samsung	702
Scientific Atlanta	008
Seawoo	780
TongKook	777, 840
Toshiba	000
Zenith	000

**Manufacturers' codes for DBS tuner**

Cyrus	200
Dae Young	735
DNT	200
DX Antenna	752
Kathrein	200
Marantz	200
Panasonic	739
Pantech	747
Philips	200
Radiola	200
RFT	200
Samsung	773
Sony	661
Toshiba	486
Ventana	200

**Manufacturers' codes for VCR**

Admiral	048
Adventura	000
Aiko	278
Aiwa	000, 037
Akai	041, 061, 281, 288
Akiba	072
Alba	020, 072, 278
Ambassador	020
Amstrad	000, 278
Anam	037, 162, 226, 240, 278, 553
Anam National	162, 226
Anitech	072
ASA	037, 081
Asha	240
Asuka	037
Audiovox	037
Baird	000, 041, 104
Basic Line	020, 072, 278
Beaumarck	240
Bell & Howell	104
Blaupunkt	034, 162, 195, 226, 227
Brandt	187, 320
Brandt Electronic	041
Bush	072, 278
Calix	037
Capehart	020
Carver	081
Catron	020
CCE	072, 278
CGE	000
Cimline	072
Cineral	278
Citizen	037, 278
Clatronic	020
Colt	072
Condor	020
Craig	037, 072, 240
Crown	020, 072, 278
Curtis Mathes	041, 162
Cybernex	240
Cyrus	081
Daewoo	020, 045, 046, 278, 368
Dansai	072
Daytron	020
De Graaf	042, 166
Decca	000, 081
Denon	042

Dual	041
Dumont	000, 081, 104
Dynatech	000
Elbe	038
Elcatech	072
Electrohome	037
Electroponic	037
Emerex	032
Emerson	000, 037, 043, 061, 278
ESC	240, 278
Ferguson	041, 320
Fidelity	000
Finlandia	081, 104
Finlux	000, 042, 081, 104
Firstline	037, 043, 045, 072
Fisher	046, 104
Frontech	020
Fuji	033
Funai	000
Garrard	000
GE	048, 240
GEC	081
General	020, 052
Go Video	432
GoldHand	072
GoldStar	037, 038, 225, 471
Goodmans	000, 020, 037, 062, 072, 278
Gradiente	000, 008
Graetz	041, 104, 240
Granada	046, 081, 104
Grandin	000, 037, 072
Grundig	072, 081, 195, 226
Hanseatic	037
Harley Davidson	000
Harman/Kardon	038, 081
Harwood	072
HCM	072
Headquarter	046
Hinari	072, 240
Hitachi	000, 041, 042, 166, 235, 240
Hypson	072
Imperial	000
Interfunk	081
ITT	041, 046, 104, 240, 384
ITV	037, 278
Jensen	041
JVC	008, 041, 067, 384
Kaisui	072
KEC	037, 278
Kenwood	038, 041, 067, 384
KLH	072
Kodak	037
Korpel	072
Lenco	278
Leyco	072
Lloyd's	000
Loewe	037, 081, 162
Logik	072, 240
Luxor	043, 046, 048, 062, 104
LXI	037
M Electronic	000
Magnasonic	278
Magnavox	000, 081
Magnin	240
Manesth	045, 072
Marantz	062, 081
Marta	037
Matsushita	162, 227



Melectronic	038
Memorex	000, 037, 046, 048, 104, 162, 240
Memphis	072
Metz	037, 162, 195, 227
MGA	043, 061, 240
MGN Technology	240
Minerva	195
Minolta	042
Mitsubishi	043, 048, 061, 067, 081, 173, 196
Motorola	048
MTC	000, 240
Multitech	000, 072
Murphy	000
NAD	058
National	226
NEC	038, 040, 041, 067, 104, 370
Neckermann	081
Nesco	072
Nikko	037
Nikon	034
Noblex	240
Nokia	041, 046, 104, 240
Nordmende	041, 320, 384
Oceanic	000, 041
Olympus	226
Optimus	037, 048, 058, 104, 162, 432
Optonica	062
Osaki	000, 037, 072
Otto Versand	081
Palladium	037, 041, 072
Panasonic	162, 225, 226, 227, 367
Pathe Marconi	041
Penney	037, 038, 040, 042, 240
Pentax	042
Perdio	000
Philco	038
Philips	062, 081, 384
Phonola	081
Pilot	037
Pioneer	058, 067, 081, 162, 235
Portland	020
Profitronic	240
Proline	000
Protec	072
Pye	081
Quarter	046
Quartz	046
Quasar	162
Quelle	081
Radio Shack	000, 037
Radiola	081
Radix	037
Randex	037
RCA	042, 048, 240
Realistic	000, 037, 046, 048, 062, 104
Rex	041, 384
Ricoh	034
Roadstar	037, 072, 240, 278
Saba	041, 320, 384
Salora	043, 046
Samsung	045, 240, 426, 432
Sanky	048
Sansui	000, 041, 067
Sanyo	046, 104, 240, 368, 369
SBR	081
Schaub Lorenz	000, 041, 104
Schneider	000, 072, 081
Scott	043, 045

Sears	000, 037, 042, 046, 104
SEG	240
SEI	081
Seleco	041
Semp	045
Sentra	020
Sharp	048, 062, 363
Shintom	072, 104
Shogun	240
Siemens	037, 081, 104, 195
Silva	037
Singer	045, 072
Sinudyne	081
Solavox	020
Sonolor	046
Sontec	037
Sony	000, 032, 033, 034
STS	042
Sunstar	000
Suntronic	000
Sylvania	000, 043, 081
Symphonic	000
Tashiko	000
Tatung	000, 041, 081
Teac	000, 041
Tec	020
Technics	162, 226
Teknika	000, 037, 052
Teleavia	041
Telefunken	041, 187, 320, 384
Tenosal	072
Tensai	000
Thomas	000
Thomson	041, 320, 384
Thorn	041, 104
TMK	240
Toshiba	041, 043, 045, 081, 366, 384
Totevision	037, 240
Uher	240
Unitech	240
Universum	000, 037, 081, 195, 240
Vector	045
Vector Research	038, 040
Victor	008, 041, 067, 384
Video Concepts	040, 045, 061
Videosonic	240
Wards	000, 042, 048, 062, 072, 081, 240
White Westinghouse	278
XR-1000	000, 072
Yamaha	038
Yamishi	072
Yokan	072
Yoko	020, 240
Zenith	000, 033, 034

Manufacturers' codes listed on pages 48 to 51 are subject to change without notice. If they are changed, this remote control cannot operate the equipment.

# Troubleshooting

Use this chart to help you solve daily operational problems. If there is any problem you cannot solve, contact your JVC service center.

PROBLEM	POSSIBLE CAUSE	SOLUTION
The display does not light up.	The power cord is not plugged in.	Plug the power cord into an AC outlet.
No sound from speakers.	Speaker signal cables are not connected.	Check speaker wiring and reconnect if necessary.
	The SPEAKERS 1 and 2 buttons are not set correctly.	Press SPEAKERS 1 and 2 correctly.
	An incorrect source is selected.	Select the correct source.
	Muting is activated.	Press MUTING to cancel the mute.
Sound from one speaker only.	Speaker signal cables are not connected properly.	Check speaker wiring and reconnect if necessary.
	The balance is set to one extreme.	Adjust the balance properly (see page 13).
Continuous hiss or buzzing during FM reception.	Incoming signal is too weak.	Connect an outdoor FM antenna or contact your dealer.
	The station is too far away.	Select a new station.
	An incorrect antenna is used.	Check with your dealer to be sure you have the correct antenna.
	Antennas are not connected properly.	Check connections.
Occasional cracking noise during FM reception.	Ignition noise from automobiles.	Move the antenna farther from automobile traffic.
No colors on the on-screen display.	The color system of the connected TV is not PAL.	Connect a PAL- or multi-color system TV.
Howling during record playing.	Your turntable is too close to speakers.	Move speakers away from the turntable.
"OVERLOAD" starts flashing on the display.	Speakers are overloaded because of high volume.	<ol style="list-style-type: none"> <li>1. Press STANDBY/ON  on the front panel to turn off the receiver.</li> <li>2. Stop the playback source.</li> <li>3. Turn on the receiver again, and adjust the volume.</li> </ol>
	Speakers are overloaded because of short circuit of speaker terminals.	Press STANDBY/ON  on the front panel, then check the speaker wiring. If "OVERLOAD" does not disappear, unplug the AC power cord, then plug it back again. If speaker wiring is not short-circuited, contact your dealer.
Remote control does not work.	The remote control mode selector is not set correctly.	Set the selector correctly either to "AUDIO/TV/VCR" or to "CATV/DBS."
	There is an obstruction in front of the remote sensor on the receiver.	Remove the obstruction.
	Batteries are weak.	Replace batteries.

## Amplifier

### Output Power

At Stereo operation:

Front channels: 100 W\* per channel, min. RMS, both channels driven into 8 Ω at 1 kHz with no more than 0.9% total harmonic distortion. (IEC268-3/DIN)

At Surround operation:

Front channels: 100 W\* per channel, min. RMS, driven into 8 Ω at 1 kHz with no more than 0.8% total harmonic distortion.

Center channel: 100 W\*, min. RMS, driven into 8 Ω at 1 kHz, with no more than 0.8% total harmonic distortion.

Rear channels: 100 W\* per channel, min. RMS, driven into 8 Ω at 1 kHz, with no more than 0.8% total harmonic distortion.

(\* Measured on AC 110 V, 127 V, 220 V and 240 V)

## Audio

Audio Input Sensitivity/Impedance (1 kHz):	PHONO (MM):	2.5 mV/47 kΩ
	CD, TAPE/MD, TV SOUND/DBS, VCR, DVD:	200 mV/47 kΩ
Audio Input (DIGITAL IN)*:	Coaxial: DIGITAL 1 (DVD):	0.5 V(p-p)/75 Ω
	Optical: DIGITAL 2 (CD), DIGITAL 3 (TV):	-21 dBm to -15 dBm (660 nm ±30 nm)
	*Corresponding to Linear PCM, Dolby Digital, DTS Digital Surround and MPEG Multichannel (with sampling frequency — 32 kHz, 44.1 kHz, 48 kHz).	
Audio Output Level:	TAPE/MD, VCR:	200 mV
Digital output:	Optical: DIGITAL OUTPUT	
	Signal wave length:	660 nm
	Output level:	-21 dBm to -15 dBm
Signal-to-Noise Ratio (*66 IHF/DIN):	PHONO:	70 dB/66 dB (at REC OUT)
	CD, TAPE/MD, TV SOUND/DBS, VCR, DVD:	87 dB/67 dB
Frequency Response (8 Ω):	PHONO:	20 Hz to 20 kHz (±1 dB)
	CD, TAPE/MD, TV SOUND/DBS, VCR, DVD:	20 Hz to 20 kHz (±1 dB)
RIAA Phono Equalization:	±1.0 dB (20 Hz to 20 kHz)	
Bass boost:	+6 dB ±1.0 dB at 100 Hz (Volume control at -30 dB)	
SEA:	Center frequencies:	100 Hz, 1 kHz, 10 kHz
	Control range:	±10 dB ±2 dB

## Video

Video Input Sensitivity/Impedance:		
Composite video:	TV SOUND/DBS, VCR, DVD:	1 V(p-p)/75 Ω
S-video:	TV SOUND/DBS, VCR, DVD: (Y: luminance):	1 V(p-p)/75 Ω
	(C: chrominance, burst):	0.286 V(p-p)/75 Ω
Video Output Level:		
Composite video:	VCR, MONITOR OUT:	1 V(p-p)/75 Ω
S-video:	VCR, MONITOR OUT: (Y: luminance):	1 V(p-p)/75 Ω
	(C: chrominance, burst):	0.286 V(p-p)/75 Ω
Synchronization:	Negative	
Signal-to-Noise Ratio:	45 dB	
On-Screen Color System:	PAL	



***FM tuner (IHF)***

Tuning Range:	87.50 MHz to 108.00 MHz	
Usable Sensitivity:	Monaural:	12.8 dBf (1.2 $\mu$ V/75 $\Omega$ )
50 dB Quieting Sensitivity:	Monaural:	21.3 dBf (3.2 $\mu$ V/75 $\Omega$ )
	Stereo:	41.3 dBf (31.5 $\mu$ V/75 $\Omega$ )
Signal-to-Noise Ratio (IHF-A weighted):	Monaural:	78 dB at 85 dBf
	Stereo:	73 dB at 85 dBf
Total Harmonic Distortion:	Monaural:	0.4% at 1 kHz
	Stereo:	0.6% at 1 kHz
Stereo Separation at REC OUT:	35 dB at 1 kHz	
Alternate Channel Selectivity:	45 dB: ( $\pm$ 400 kHz)	
Frequency Response:	30 Hz to 15 kHz: (+0.5 dB, -3 dB)	

***AM tuner***

Tuning Range:	531 kHz to 1 602 kHz (at 9 kHz intervals) 530 kHz to 1 600 kHz (at 10 kHz intervals)	
Usable Sensitivity:	Loop antenna	400 $\mu$ V/m
Signal-to-Noise Ratio	50 dB (100 mV/m)	

***General***

Power Requirements:	AC 110 V/127 V/220 V/230 V – 240 V $\sim$ , adjustable with the voltage selector, 50 Hz/60 Hz	
Power Consumption:	200 W(at operation) 5 W (in standby mode)	
Dimensions (W x H x D):	435 mm x 157 mm x 412.5 mm	
Mass:	11.3kg	

Designs & specifications are subject to change without notice.

## Mains (AC) Line Instruction (not applicable for Europe, U.S.A., Canada, Australia and U.K.)

## Instrucción sobre la línea de la red (CA) (no aplicable para Europa, EE.UU., Canadá, Australia, ni el Reino Unido)

## Instrução sobre a tensão da rede eléctrica (CA) (não aplicável para a Europa, os E.U.A., o Canadá, a Austrália e o Reino Unido)

## 主 (AC) 电源线路说明 (不适用于欧洲、美国、加拿大、澳洲及英国型号)

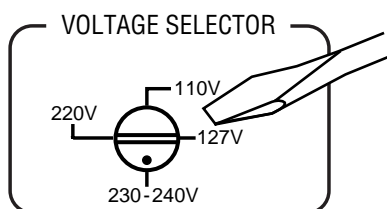
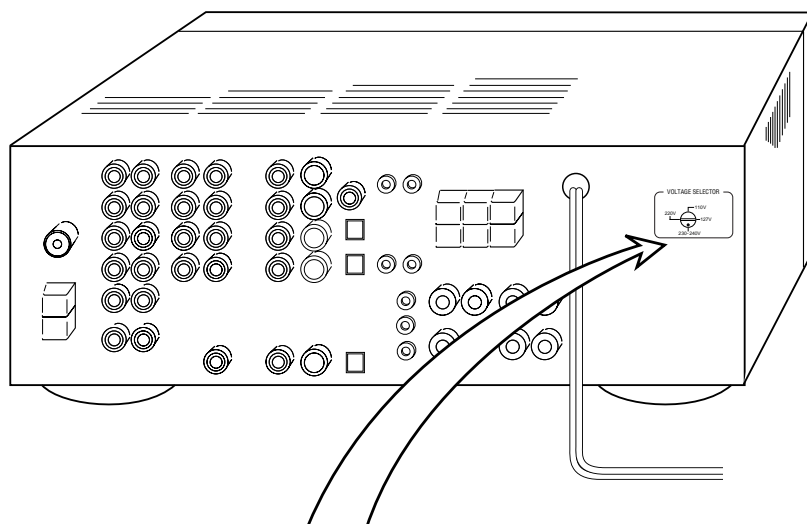

### CAUTION for mains (AC) line

BEFORE PLUGGING IN, do check that your mains (AC) line voltage corresponds with the position of the voltage selector switch provided on the outside of this equipment and, if different, reset the voltage selector switch, to prevent from a damage or risk of fire/electric shock.

### PRECAUCIÓN para la línea de la red (CA)

ANTES DE ENCHUFAR EL EQUIPO, compruebe si la tensión de la línea de la red (CA) corresponde con la posición del selector de tensión situado en la parte exterior del equipo, y si es diferente, reajuste el selector de tensión para evitar el riesgo de incendios/ descargas eléctricas.

### PRECAUÇÃO para a ligação à tensão da rede (CA)

ANTES DE LIGAR O APARELHO A UMA TOMADA DA REDE, verifique se a tensão da rede CA corresponde à posição do selector de voltagem localizado na parte externa deste equipamento. Caso não corresponda, reajuste o selector de voltagem a fim de evitar avarias ou riscos de incêndio e choque eléctrico.

### 有关主(AC)电源线路的注意事项

接插电源以前, 务请检查当地的主 (AC) 电源线路电压是否和位于本机外面的电压选择开关设定的位置一致。如果不一致, 即重新设定电压选择开关使符合当地电压, 以免损坏机器或引起火灾/触电的危险。

**JVC**  
VICTOR COMPANY OF JAPAN, LIMITED

## Free Manuals Download Website

<http://myh66.com>

<http://usermanuals.us>

<http://www.somanuals.com>

<http://www.4manuals.cc>

<http://www.manual-lib.com>

<http://www.404manual.com>

<http://www.luxmanual.com>

<http://aubethermostatmanual.com>

Golf course search by state

<http://golfingnear.com>

Email search by domain

<http://emailbydomain.com>

Auto manuals search

<http://auto.somanuals.com>

TV manuals search

<http://tv.somanuals.com>