

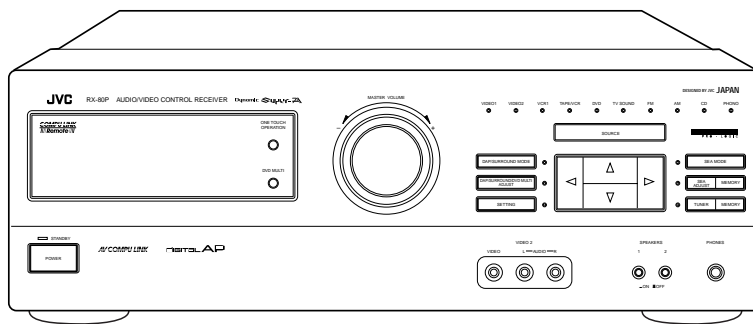

AUDIO/VIDEO CONTROL RECEIVER

AV功率放大器 (带收音)

RX-80PGD



Dynamic **Super-A**

COMPU LINK
Remote

DOLBY SURROUND
PRO • LOGIC

AV COMPU LINK

DIGITAL AP

INSTRUCTIONS

使用说明书

For Customer Use:

Enter below the Model No. and Serial No. which are located either on the rear, bottom or side of the cabinet. Retain this information for future reference.

Model No. _____

Serial No. _____

LVT0101-001B
[UF]

Warnings, Cautions and Others / 警告, 注意及其它须知事项

Caution — POWER switch!

Disconnect the mains plug to shut the power off completely. The POWER switch in any position does not disconnect the mains line. The power can be remote controlled.

注意—电源开关！

无论电源开关在什么位置，电源线的电源还是没有被切断，若要将电源完全切断，应把电源插头拔离插座。电源可用遥控器控制。

CAUTION

To reduce the risk of electrical shocks, fire, etc.:

1. Do not remove screws, covers or cabinet.
2. Do not expose this appliance to rain or moisture.

警告

为了减低触电，火灾等危险：

1. 请勿擅自卸下螺丝钉，盖子或机壳。
2. 切勿让本机受雨淋或置潮湿环境中。

Caution: Proper Ventilation

To avoid risk of electric shock and fire and to protect from damage. Locate the apparatus as follows:

- Front: No obstructions open spacing.
 - Sides: No obstructions in 10 cm from the sides.
 - Top: No obstructions in 10 cm from the top.
 - Back: No obstructions in 15 cm from the back
 - Bottom: No obstructions, place on the level surface.
- In addition, maintain the best possible air circulation as illustrated.

注意: 正确的通风方法

为防止触电、火灾以及避免损坏,

按如下要求放置机器:

- 前面: 留下空间不要放置障碍物。
 - 侧面: 侧面10厘米之内不要放置障碍物。
 - 上面: 上面10厘米之内不要放置障碍物。
 - 后面: 后面15厘米之内不要放置障碍物。
 - 底部: 不要放置障碍物, 水平放置。
- 此外, 如图所示, 尽可能保持最佳的空气循环。

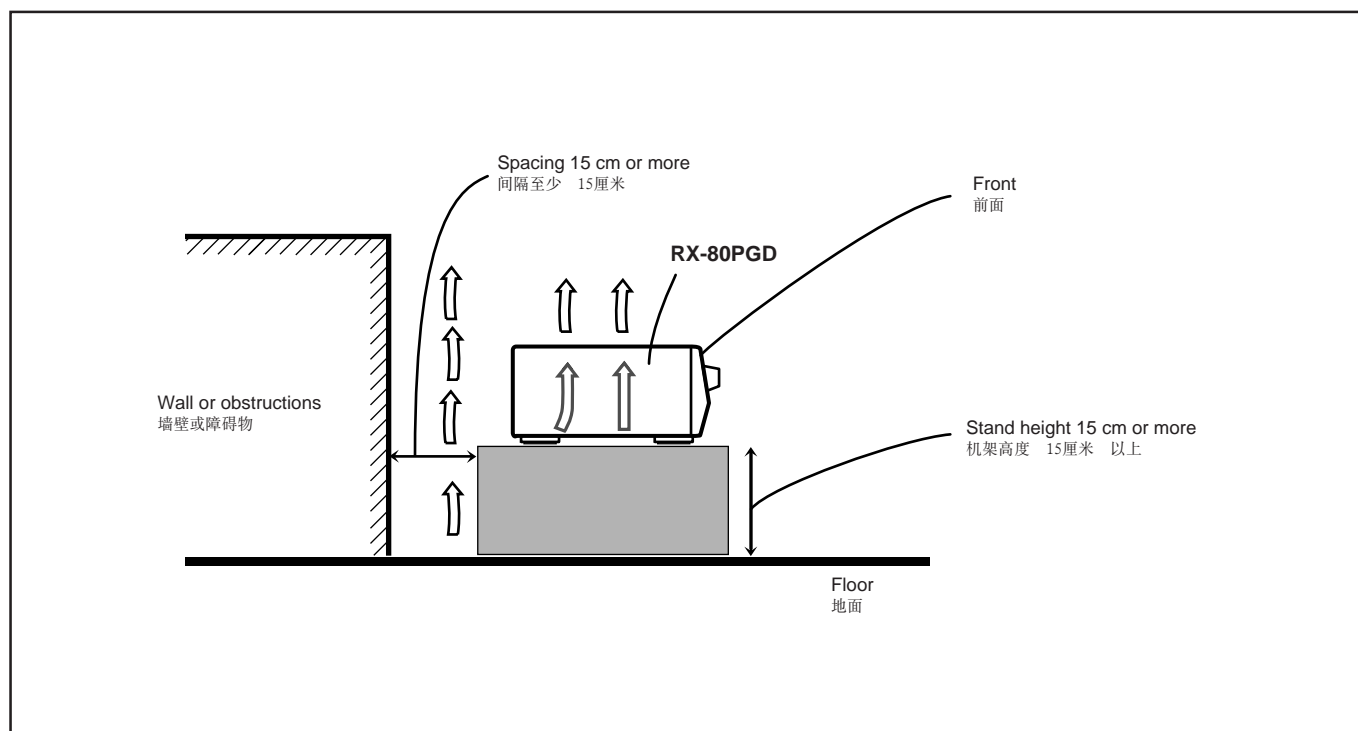

Getting Started	2
Before Installation	2
Checking the Supplied Accessories	2
Switches, Buttons and Controls	3
Connecting the FM and AM Antennas	5
Connecting the Speakers	6
Connecting Audio/Video Components	8
Connecting the Power Cord	11
Putting Batteries in the Remote Control	11
Basic Operations	12
Turning the Power On and Off	12
Selecting the Source to Play	12
Adjusting the Volume	13
Selecting the Front Speakers	13
Muting the Sound	14
Recording a Source	14
Basic Settings	15
Adjusting the Front Speaker Output Balance	15
Listening at Low Volume (Loudness)	15
Using the Sleep Timer	16
Selecting the Center Speaker Size	17
Using Visual Confirmation	18
One Touch Operation	19
About the One Touch Operation	19
Using the One Touch Operation	19
Receiving Radio Broadcasts	20
Tuning in Stations Manually	20
Using Preset Tuning	21
Selecting the FM Reception Mode	22
Assigning Names to Preset Stations	23
Using the SEA Modes	24
Selecting Your Favorite SEA Mode	24
Creating Your Own SEA Mode	25
Activating the Surround Sounds	26
Using the DAP Modes	27
Using the DVD MULTI Playback Mode	29
Using the Surround Modes	31
Using the On-Screen Display to Control the Receiver	37
COMPU LINK Remote Control System	41
AV COMPU LINK Remote Control System	42
Using the Remote Control for Operating JVC's Audio/Video Components	44
Operating Other Manufactures' TV	48
Troubleshooting	50
Specifications	51



This mark indicates that you can also use the menu function to do the same operations. Actual operations using the menu function are explained on the pages indicated next to the marks.

This section explains how to connect audio/video components and speakers to the receiver, and how to connect the power supply.

Before Installation

General

- Be sure your hands are dry.
- Turn the power off to all components.
- Read the manuals supplied with the components you are going to connect.

Locations

- Install the receiver in a location that is level and protected from moisture.
- The temperature around the receiver must be between -5° and 35° C .
- Make sure there is good ventilation around the receiver. Poor ventilation could cause overheating and damage the receiver.

Handling the receiver

- Do not insert any metal object into the receiver.
 - Do not disassemble the receiver or remove screws, covers, or cabinet.
 - Do not expose the receiver to rain or moisture.
-

Checking the Supplied Accessories

Check to be sure you have all of the following items, which are supplied with the receiver. The number in the parenthesis indicates the quantity of the pieces supplied.

- **Remote Control (1)**
- **Batteries (2)**
- **AM Loop Antenna (1)**
- **FM Antenna (1)**
- **Audio Signal Attenuating Cord (1)**
- **AV COMPU LINK Cable (1)**

If anything is missing, contact your dealer immediately.

Switches, Buttons and Controls

Become familiar with the main switches and controls on your receiver before use.

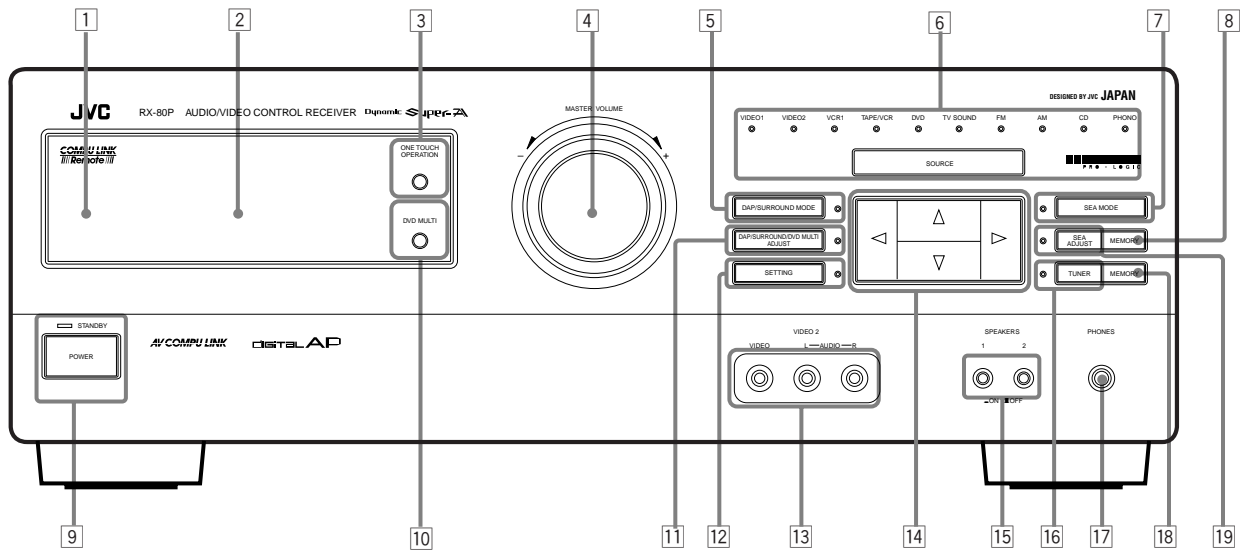

Refer to the pages in parentheses for details.

Front Panel

- 1 Remote sensor (11)
- 2 Display (12)
- 3 ONE TOUCH OPERATION button and lamp (19)
- 4 MASTER VOLUME control (13)
- 5 DAP/SURROUND MODE button and lamp (27, 32)
- 6 SOURCE button and lamps (12)
- 7 SEA MODE button and lamp (24)
- 8 MEMORY button for SEA adjustments (25)
- 9 POWER button and STANDBY lamp (12)
- 10 DVD MULTI button and lamp (12)
- 11 DAP/SURROUND/DVD MULTI ADJUST button and lamp (27, 29, 32)
- 12 SETTING button and lamp (15)
- 13 VIDEO 2 input jacks (10)
- 14 Control $\Delta / \nabla / \triangleleft / \triangleright$ buttons
- 15 SPEAKERS 1/2 buttons (13)
- 16 TUNER button and lamp (20)
- 17 PHONES jack (14)
- 18 MEMORY button for presetting channels (21)
- 19 SEA ADJUST button and lamp (25)

IMPORTANT

To use Control $\Delta / \nabla / \triangleleft / \triangleright$ buttons (14) on the front panel:

What these buttons actually do depends on which function you are trying to adjust. Before using these buttons, select the function by pressing one of **the function selecting buttons** (5, 6, 7, 11, 12, 16, 19), and being sure its lamp is lit.

However, pressing MENU SET (33) on the remote control overrides the selected function and causes Control $\Delta / \nabla / \triangleleft / \triangleright$ button to act like $\Delta / \nabla / \triangleleft / \triangleright$ buttons (34) of the ON SCREEN CONTROL section of the remote control (though a lamp for the selected function remains lit).

To return the Control $\Delta / \nabla / \triangleleft / \triangleright$ buttons to their usual behavior under the selected function, press the function button again.

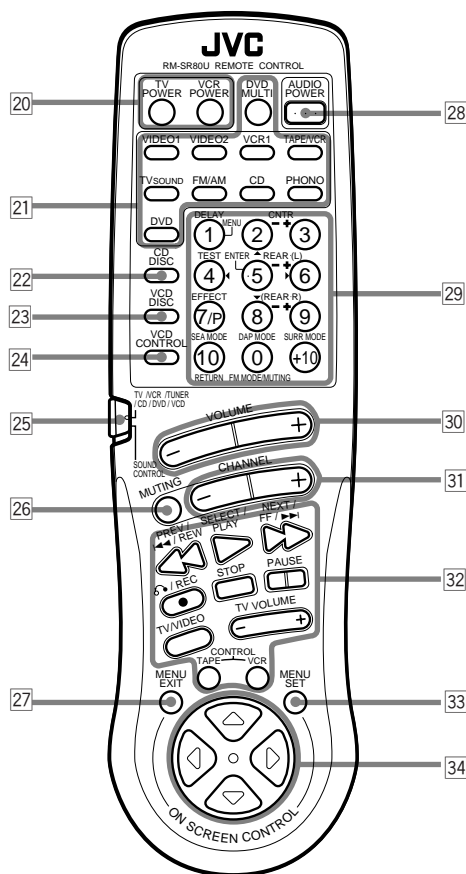

Remote Control Unit

- 20 TV POWER and VCR POWER buttons (46, 47)
- 21 Source selecting buttons (13)
- 22 CD DISC button (45)
- 23 VCD DISC button (47)
- 24 VCD CONTROL button (47)
- 25 Remote control mode selector (TV / VCR / TUNER / CD / DVD / VCD, SOUND CONTROL) (12, 24)
- 26 MUTE button (14)
- 27 MENU EXIT button (37)
- 28 AUDIO POWER button (12)
- 29
 - 10 keys for selecting preset channel (22)
 - 10 keys for adjusting sound (24, 28, 30, 35)
 - Operating buttons for audio/video components (44, 46)
- 30 VOLUME buttons (+/-) (13)
- 31 CHANNEL buttons (+/-) (46, 47)
- 32 Operating buttons for audio/video components (44, 46)
- 33 MENU SET button (37)
- 34 $\Delta / \nabla / \triangleleft / \triangleright$ buttons of the ON SCREEN CONTROL section (37)

IMPORTANT

When using the remote control:

Check to see if its remote control mode selector (25) is set to the correct position.

Normally, set it to the "TV / VCR / TUNER / CD / DVD / VCD" position.

To activate the 10 keys for adjusting the sound, set it to the "SOUND CONTROL" position.

About $\Delta / \nabla / \triangleleft / \triangleright$ buttons (34) of the ON SCREEN CONTROL section on the remote control:

If you press these buttons, the menu function starts operating. So, make sure you are showing the on-screen display on the TV before pressing these buttons.

Connecting the FM and AM Antennas

FM Antenna Connections

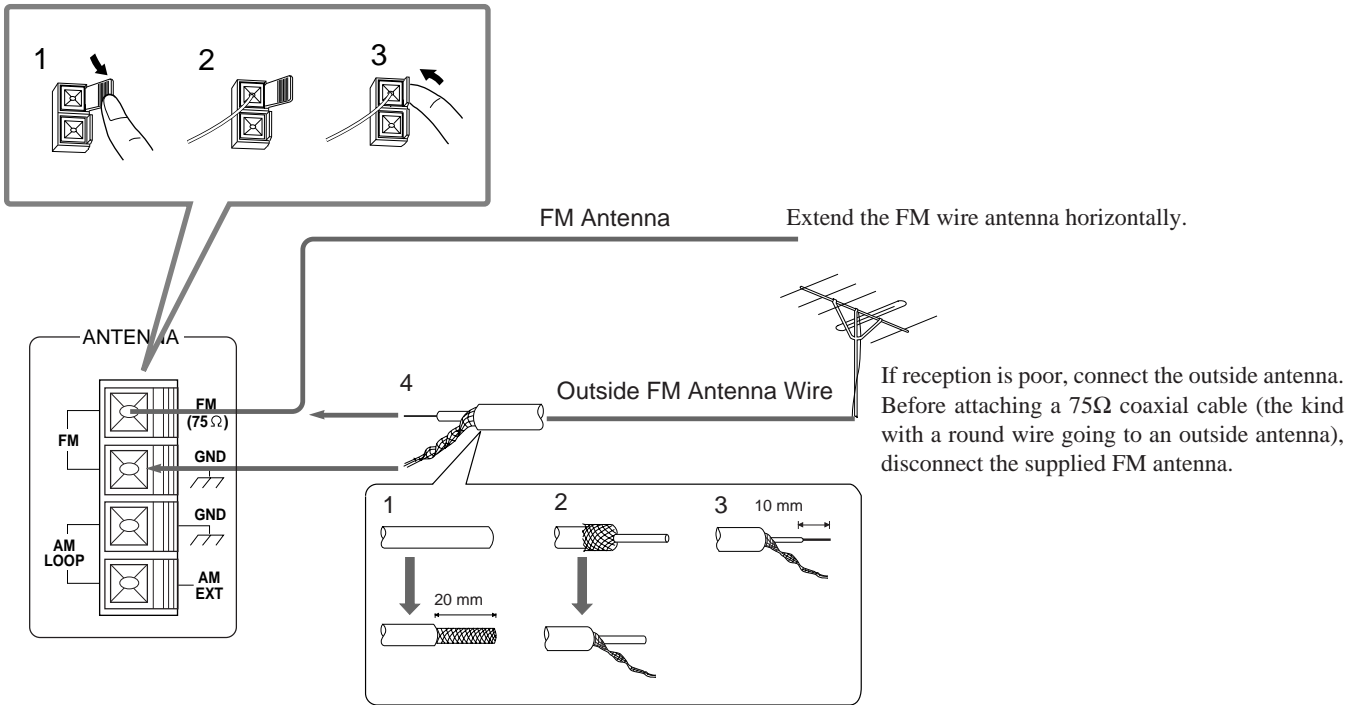

How to strip the 75Ω coaxial cable and connect it to the FM terminals

1. Strip back the outside covering of the 75Ω coaxial cable to expose the braided metallic mesh about 20 mm.
2. Pull the mesh back and twist it into a single connector, as shown in the illustration above.
3. Strip the insulation about 10 mm back from the central wire.
4. Insert the twisted mesh and the central wire to the FM terminals, as shown in the illustration above.

AM Antenna Connections

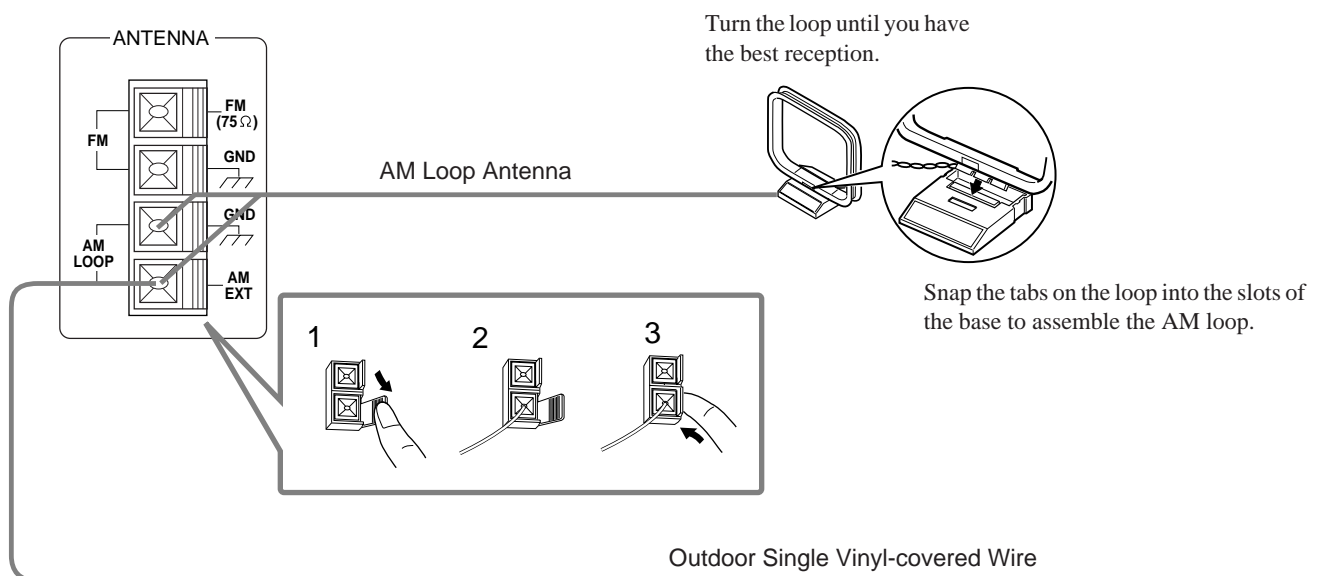

Note:

Make sure the antenna conductors do not touch any other terminals, connecting cords and power cord. This could cause poor reception.

If reception is poor, connect an outdoor single vinyl-covered wire to the AM EXT terminal. (Keep the AM loop antenna connected.)

Connecting the Speakers

You can connect the following speakers:

- Two pairs of front speakers to produce normal stereo sound.
- One pair of rear speakers to enjoy the surround effect.
- One center speaker to produce more effective surround effect (to emphasize human voices).
- One subwoofer to enhance the bass.

For each speaker (except for subwoofer), connect the black (-) and red (+) terminals on the rear panel to the black (-) and red (+) terminals marked on the speakers. For connecting a subwoofer, see page 7.

CAUTION:

Use speakers with the SPEAKER IMPEDANCE indicated by the speaker terminals.

Connecting the front speakers

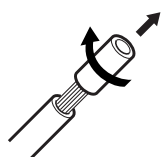

Cut, twist and remove the insulation at the end of each speaker signal cable first, and then, connect the front speakers to the FRONT SPEAKERS terminals by using the cables.

You can connect two pairs of front speakers (one pair to the FRONT SPEAKERS ① terminals, and another pair to the FRONT SPEAKERS ② terminals).

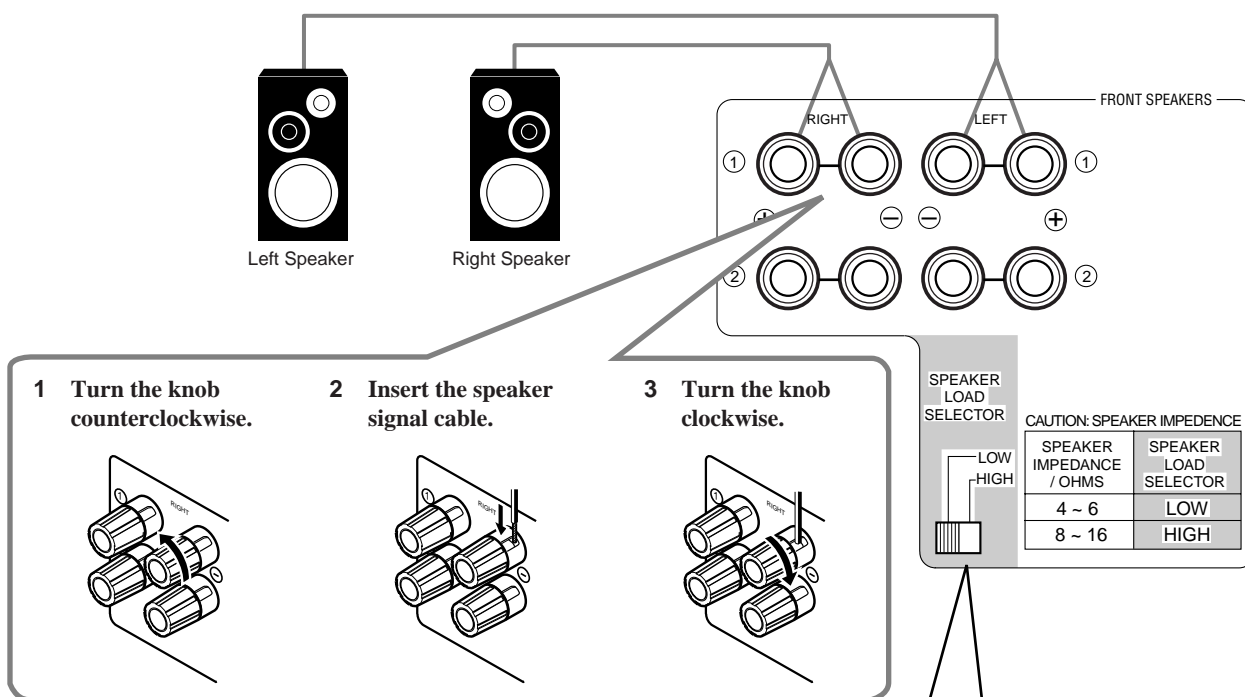

Notes:

- To obtain the best possible output power from the receiver, and to prevent the receiver from being overheated, the receiver has the SPEAKER LOAD SELECTOR which should be set to match the impedance of the connected speakers.
Set this selector according to the indications by the FRONT SPEAKERS terminals.
- When you connect two pairs of the speakers to the FRONT SPEAKERS terminals, use the speakers having the impedance within the same range.

Connecting the rear and center speakers

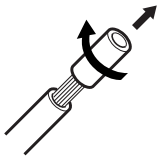

Cut, twist and remove the insulation at the end of each speaker signal cable first, and then, connect rear speakers to the REAR SPEAKERS terminals and a center speaker to the CENTER SPEAKER terminals by using the cables.

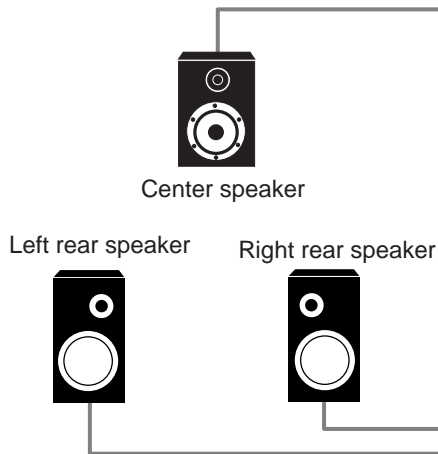

1 Open the terminal and then insert the speaker signal cable.



2 Close the terminal.

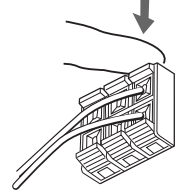

Note:

You can register the center speaker size after you finish its connection. If you register it, you do not have to set the center speaker mode when setting the surround mode. (If you do not use a center speaker, register that information.) See page 17.

Connecting the subwoofer speaker

You can enhance the bass by connecting a subwoofer.

Connect the input jack of a powered subwoofer to the SUBWOOFER OUT jack on the rear panel, using a cable with RCA pin plugs.



Powered subwoofer



Connecting Audio/Video Components

You can connect the following audio/video components to this receiver using cables with RCA pin plugs (not supplied). Refer also to the manuals supplied with your components. If you want to connect a component not listed in the table below, refer to the manual supplied with it.

Audio Components	Video Components
• Turntable	• DVD (Digital Video Disc) player
• CD player	• VCD (Video CD) player
• Cassette deck	• TV
_____	• VCR(s)
_____	• Video camera

Notes:

- If you connect a sound-enhancing device such as a graphic equalizer between the source components and this receiver, the sound output through this receiver may be distorted.
- You can connect either a cassette deck or a VCR to the TAPE/VCR jacks, whichever you want.
- Any turntables incorporating a small-output cartridge such as an MC (moving-coil type) must be connected to this receiver through a commercial head amplifier or step-up transformer. Direct connection may result in insufficient volume.

Audio component connections

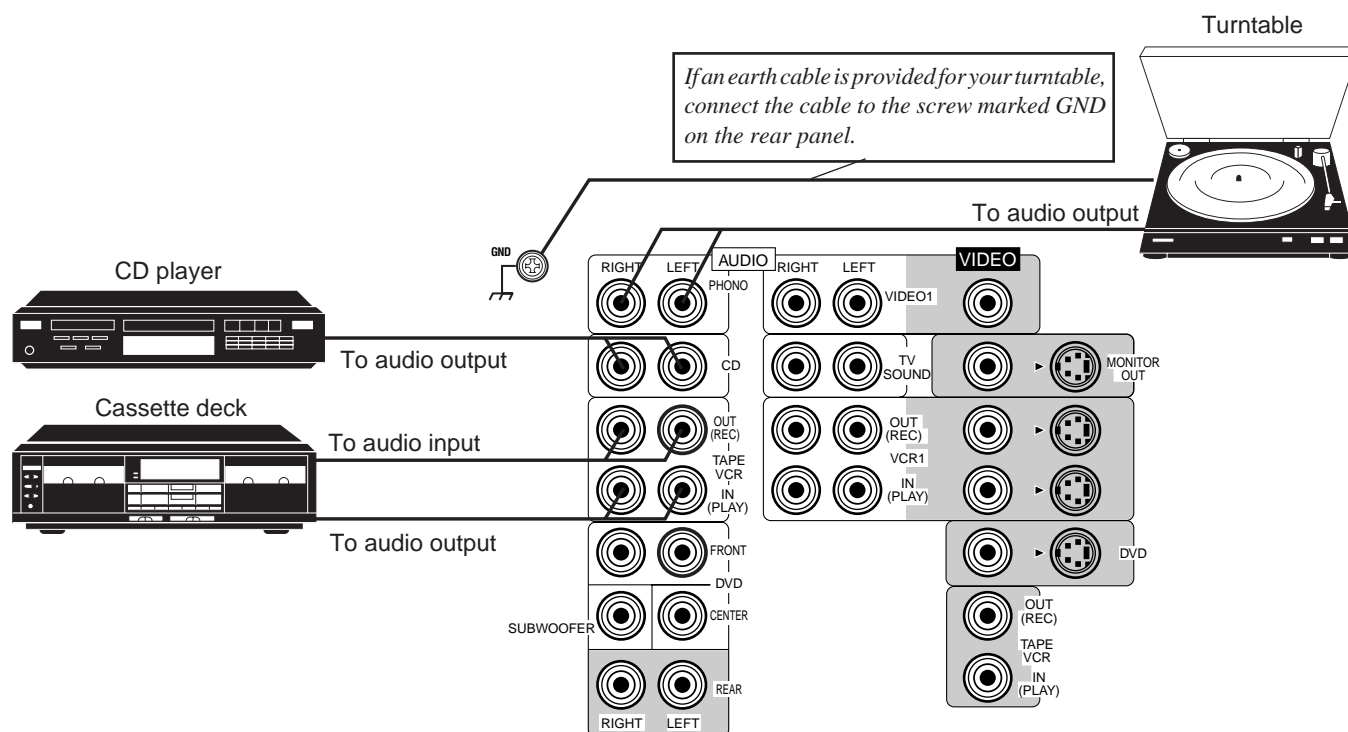

If your audio components have a COMPU LINK-3 terminal

The COMPU LINK remote control system allows you to control other JVC audio components from the receiver or vice versa.

Connect your audio components and the receiver with the cable (monaural mini-plug supplied with those components) as well as the connection above.

For detailed information about the connection and the COMPU LINK-3 remote control system, see page 41.

Notes:

- If you want to operate a cassette deck using the COMPU LINK remote control system, connect the cassette deck to the TAPE/VCR jacks, not to the VCR1 jacks.
- The COMPU LINK-3 remote control system is the upgraded version of the COMPU LINK-1 and COMPU LINK-2. Even if your component has the COMPU LINK-1 or COMPU LINK-2 jacks, you can still connect it in the COMPU LINK-3 remote control system, but some functions may not work correctly.

Video component connections

If your video components have S-video (Y/C-separation) terminals, connect them using S-video cables (not supplied). Connecting these video components through the S-video input/output terminals will give you can get better picture playback quality.

IMPORTANT

This receiver is equipped with both the composite video and S-video input/output terminals for connecting video components. You do not have to connect both the composite video and S-video terminals.

However, **remember that the video signals from the composite video input terminals on the rear are output only through the composite video output terminals, while the ones from the S-video input terminals on the rear are output only through the S-video output terminals.**

Therefore, if a recording video equipment and a playing video equipment are connected to the receiver through the different video terminals, you cannot record the picture from the playing equipment on the recording equipment. In addition, if the TV and a playing video equipment are connected to the receiver through the different video terminals, you cannot view the playback picture from the playing equipment on the TV.

To view and record the playback picture from the video components connected to the VIDEO1, VIDEO2 and TAPE/VCR jacks, you must connect the TV and the recording video equipment through the composite video terminals.

Note:

When connecting an audio/video component (ex.: Video CD player) with "karaoke" — singing along — function, use the audio signal attenuating cord **supplied with this receiver**. If not, sound may be distorted.

TV connection

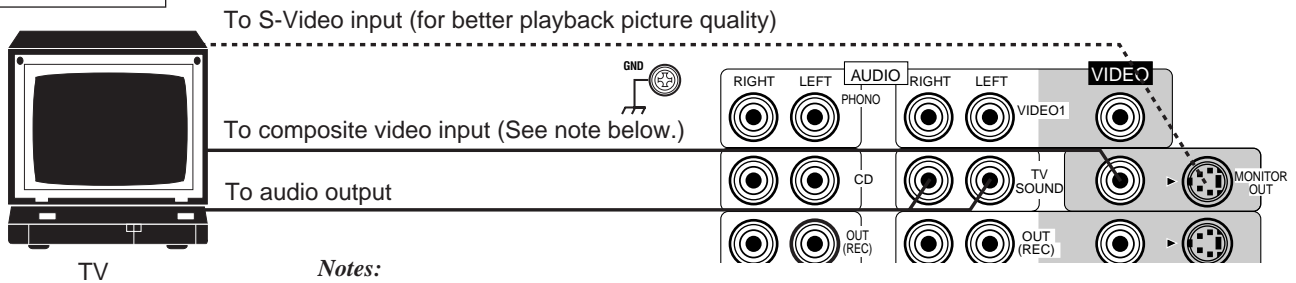

Notes:

- When connecting a JVC TV:
 - If you use the AV COMPU LINK remote control system to operate the TV, connect the receiver to the **Video Input 2 jack** on the TV.
 - If you do not use the AV COMPU LINK remote control system to operate TV, connect the receiver to the **Video Input 1 jack** on the TV.
- Use the video components of the PAL color system.

DVD player connection

- When you play back a disc on the DVD player in stereo (or the audio output setting of the DVD player is mixed to two front channels):

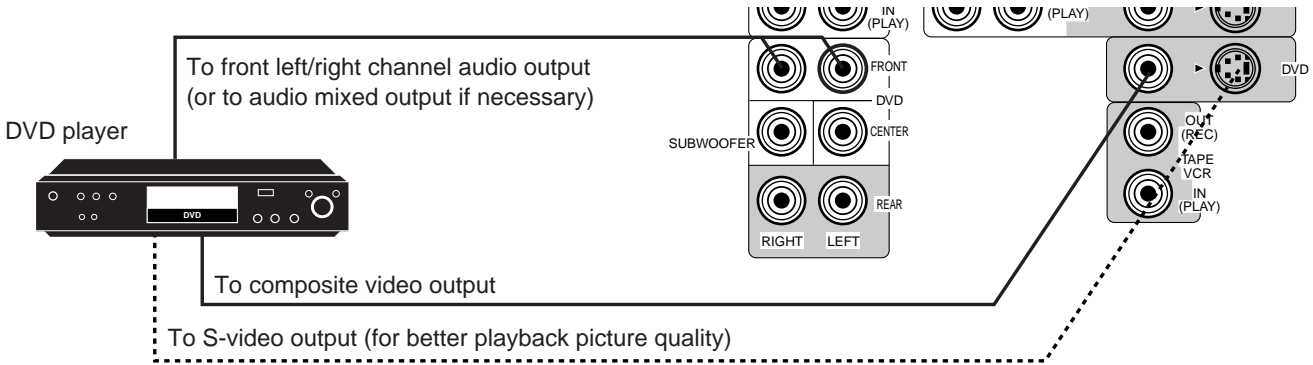

- When you play back a disc on the DVD player with its analog discrete output mode (5.1 CH reproduction) selected:

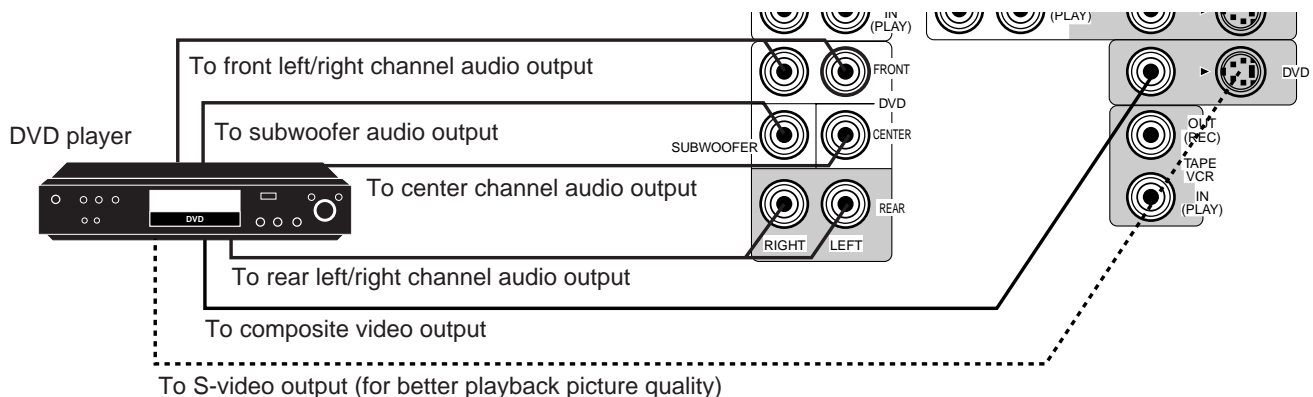

VCR and Video CD player connection

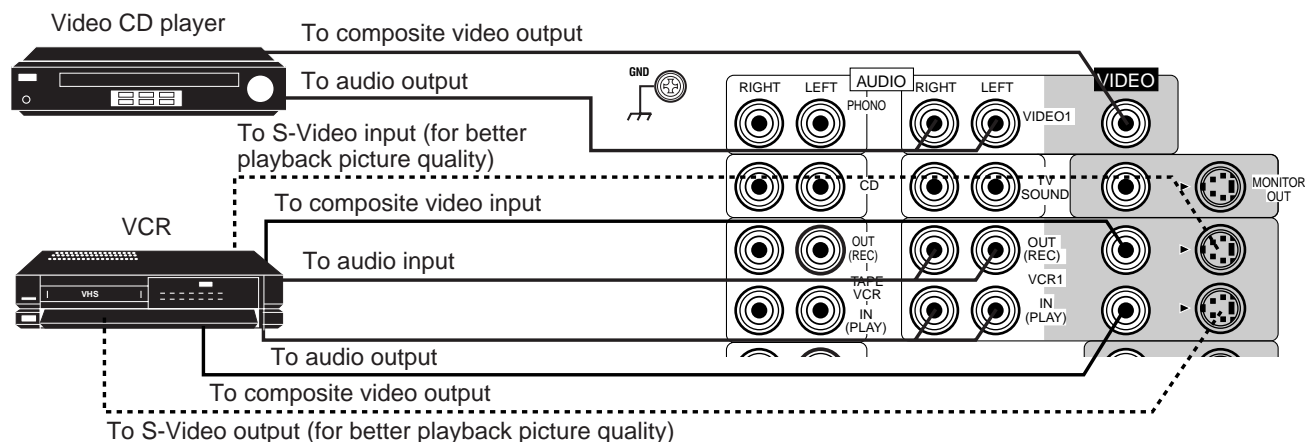

Note:

When connecting an audio/video component (ex.: Video CD player) with “karaoke” — singing along — function, use the audio signal attenuating cord **supplied with this receiver**. If not, sound may be distorted.

Another VCR connection

If you are not using a cassette deck, you can connect another VCR to the TAPE/VCR jacks.

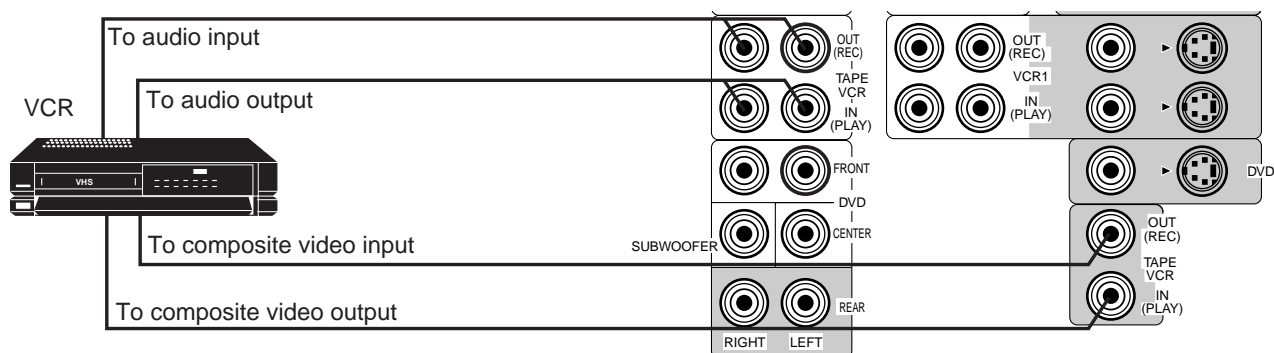

Video camera connection

You can use the VIDEO 2 input jacks on the front panel. These jacks are convenient for connecting and disconnecting the component frequently.

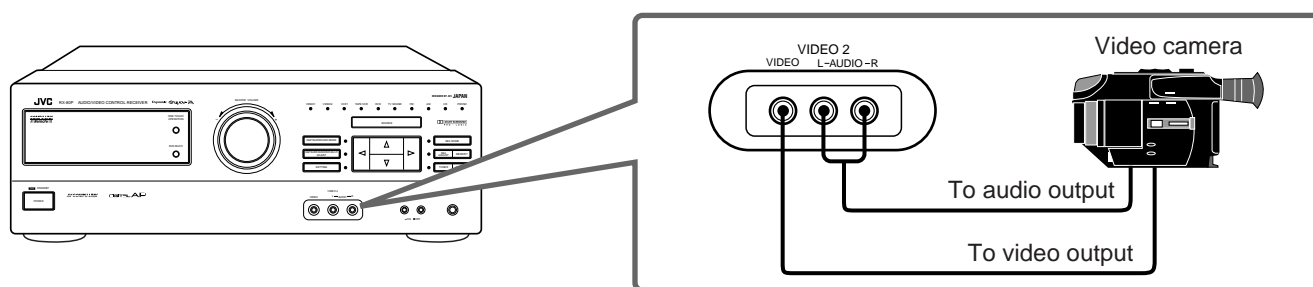

If your video components have an AV COMPU LINK terminal

The AV COMPU LINK remote control system allows you to control other JVC video components from the receiver or vice versa.

For detailed information about the connection and the AV COMPU LINK remote control system, see page 42.

Notes:

- The AV COMPU LINK remote control system cannot control the video components connected to the VIDEO1, VIDEO2, and TAPE/VCR jacks on the receiver, but can control only the VCR connected to the VCR1 jacks and the DVD player connected to the DVD jacks. You cannot connect two VCRs into the AV COMPU LINK remote control system.
- Some VCRs use the AV COMPU LINK jacks for the SWAP editing. However, you cannot use both the AV COMPU LINK remote control and the SWAP editing at the same time. For the SWAP editing, see the manual supplied with the VCR.

Connecting the Power Cord

Before plugging the receiver into an AC outlet, make sure that all connections have been made. When the power cord is connected, the STANDBY lamp above the POWER button lights up.

Keep the power cord away from the connecting cables for the TV, VCR, and antenna. The power cord may cause noise or screen interference. We recommend that you use a coaxial cable to connect the antenna, since it is well-shielded against interference.

Notes:

- A small amount of power is always consumed even in standby mode. To switch off the power completely, unplug the power cord from the AC outlet.
- If the power cord is unplugged or a power failure occurs, preset settings will be erased in a few days.

CAUTIONS:

- Do not touch the power cord with wet hands.
- Do not pull on the power cord to unplug the cord. When unplugging the cord, always grasp the plug so as not to damage the cord.

Putting Batteries in the Remote Control

Before using the remote control, put two supplied batteries first. When using the remote control, aim the remote control directly at the remote sensor on the receiver.

1. On the back of the remote control, remove the cover as illustrated.
2. Insert batteries. Make sure to observe the proper polarity: (+) to (+) and (-) to (-).
3. Replace the cover in.

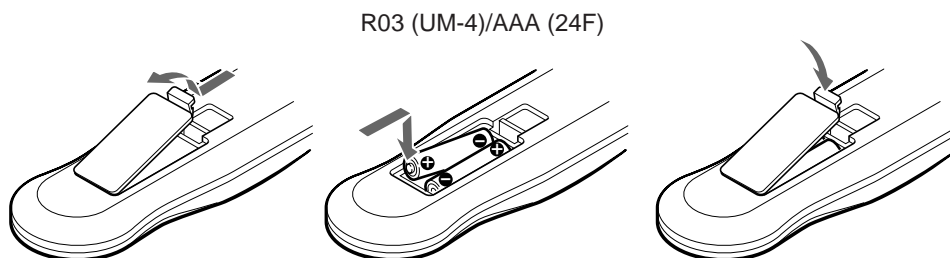

If the range or effectiveness of the remote control decreases, replace the batteries. Use two R03 (UM-4)/AAA (24F) type dry-cell batteries.

CAUTIONS:

Follow these precautions to avoid leaking or cracking cells:

- Place batteries in the remote control so they match the polarity indicated: (+) to (+) and (-) to (-).
- Use the correct type of batteries. Batteries that look similar may differ in voltage.
- Always replace both batteries at the same time.
- Do not expose batteries to heat or flame.

The following operations are commonly used when you play any sound source.

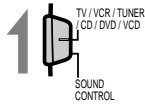

IMPORTANT

When using the Remote Control, check to see if its remote control mode selector is set to the “TV / VCR / TUNER / CD / DVD / VCD” position.

Turning the Power On and Off

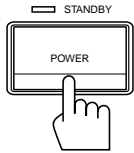

On the front panel:

To turn on the power, press POWER.

The STANDBY lamp goes off. The name of the current source appears on the display.

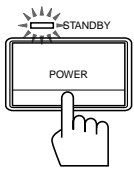

Front panel

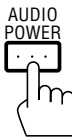

Remote Control

Current source name appears

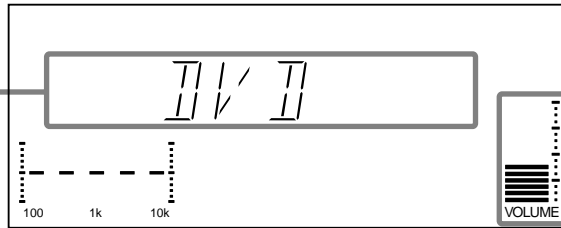

Volume level is also shown here whenever the power is on.

To turn off the power, press POWER again.

The STANDBY lamp lights up.

From the remote control:

To turn on the power, press AUDIO POWER.

The STANDBY lamp goes off. The name of the current source appears on the display.

To turn off the power, press AUDIO POWER again.

The STANDBY lamp lights up.



See also page 37.

Selecting the Source to Play

You need to select the source before you start playing any source.

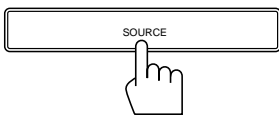

On the front panel:

1. Press SOURCE so that the Control Δ / ∇ / \triangleleft / \triangleright buttons work for selecting the source.

2. Press Control Δ / ∇ until the source name you want appears on the display.

The selected source lamp also lights up.

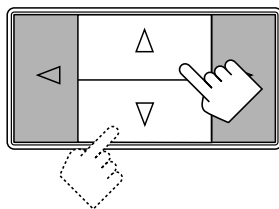

Front panel



Selected source name appears

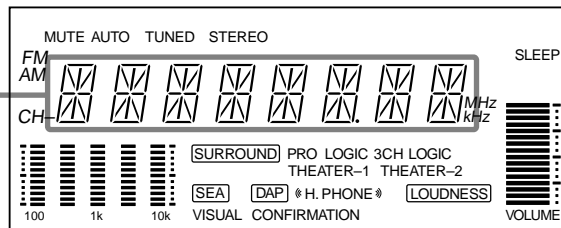

For selecting DVD MULTI playback mode as the source:

Press DVD MULTI so that the lamp above the button lights up.

Each time you press the button, the DVD MULTI playback mode turns on and off, and the “DVD” and “DVDMULTI” alternately appears on the display.

- Select “DVD” when you play back a disc in stereo or the audio output setting of the DVD player is mixed to two front channels.
- Select “DVDMULTI” when you play back a disc on the DVD player with its analog discrete output mode (5.1 CH reproduction) selected. To enjoy “DVDMULTI” mode, see page 29.

Notes:

- You can change the source to another even while the DVD MULTI lamp is lit.
- You can also select “DVDMULTI” by pressing Control \triangleleft / \triangleright when “DVD” is selected.

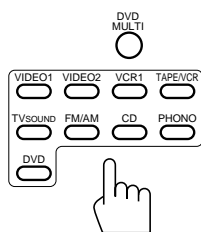

Remote Control

From the remote control:**Press one of the Source selecting buttons you want.**

DVD	Play back a stereo digital video disc.
DVD MULTI	Play back a digital video disc using the analog discrete output mode (5.1 CH reproduction) on the DVD player. Each time you press the button, the DVD MULTI playback mode turns on and off.
VIDEO1	Play back a video source on the video component connected to the VIDEO1 jacks.
VIDEO2	Play back a video source on the video component connected to the VIDEO2 jacks.
VCR1	Play back a video source on the video component connected to the VCR1 jacks.
TV SOUND	Listen to TV sounds.
FM/AM*	Listen to the radio. Each time you press the button, the band alternates between FM and AM.
TAPE/VCR*	Listen to a cassette tape (or play back a video source) connected to the TAPE/VCR jacks.
CD*	Listen to a CD.
PHONO*	Listen to a record.

Note:

When you press one of the Source selecting buttons marked above with an asterisk (*), the receiver automatically turns on.

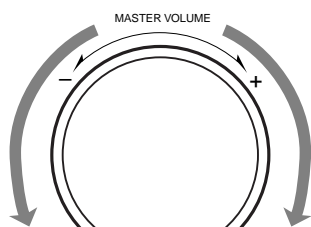
Adjusting the Volume

Front panel

When you change the volume level, the volume level is shown on the display.

On the front panel:

To increase the volume, turn MASTER VOLUME clockwise.

To decrease the volume, turn MASTER VOLUME counterclockwise.

Note:

When you turn MASTER VOLUME **rapidly**, the volume level also changes **rapidly**.

When you turn MASTER VOLUME **slowly**, the volume level also changes **slowly**.

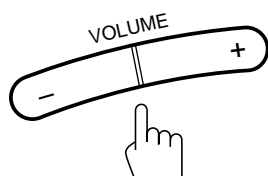

Remote Control

From the remote control:

To increase the volume, press VOLUME +.

To decrease the volume, press VOLUME -.

CAUTION:

Always set the volume level to the minimum before starting any source. If the volume level is left turned up, the sudden blast of sound energy can permanently damage your hearing and/ or ruin your speakers.

Selecting the Front Speakers

Front panel

On the front panel only:

When you have connected two pairs of the front speakers, you can select which to use. Pressing SPEAKERS 1 or SPEAKERS 2 to set it in the **ON** position activates the respective pair of the speakers.

To use the speakers connected to the FRONT SPEAKERS ① terminals, press SPEAKERS 1 to set it in the **ON** position, and press SPEAKERS 2 to set it in the **OFF** position.

To use the speakers connected to the FRONT SPEAKERS ② terminals, press SPEAKERS 2 to set it in the **ON** position, and press SPEAKERS 1 to set it in the **OFF** position.

To use both pairs of the speakers, press both SPEAKERS 1 and 2 to set them in the **ON** position.

To use neither pair of the speakers, press both SPEAKERS 1 and 2 to set them in the **OFF** position.

Note:

When only one set of the speakers is connected to either the FRONT SPEAKERS ① or ② terminals, do not press both SPEAKERS 1 and 2 to set them in the **ON** position. If you do, no sound comes out of the front speakers.

Listening with Headphones

A standard pair of headphones can be connected to the PHONES jack on the front panel.

To listen with only headphones, press both SPEAKERS 1 and 2 to set them in the **■OFF** position. No sound comes out of the front speakers.

CAUTION:

Be sure to turn down the volume before connecting or putting on headphones, as high volume can damage both the headphones and your hearing.

Muting the Sound



Remote Control

From the remote control only:

To mute the sound through all the speakers and headphones connected, press MUTING so that "MUTE" appears on the display and the volume turns off.

To cancel the mute, press MUTING again so that "OFF" appears on the display. Turning MASTER VOLUME or pressing VOLUME +/- also restores the sound at the previous volume level.

Recording a Source

You can record any source playing through the receiver to the cassette deck (or VCR) connected to the TAPE/ VCR jacks and the VCR connected to the VCR1 jacks at the same time.

While recording, you can listen to the selected sound source at whatever sound level you like, without affecting the sound levels of the recording.

Note:

The output volume level, SEA, DAP and surround adjustments cannot affect the recording.

Basic Settings

Some of the following settings are required after connecting and positioning your speakers in your listening room, while others will make operations easier.



See also page 37.

Adjusting the Front Speaker Output Balance

If the sounds you hear from the front right and left speakers are unequal, you can adjust the speaker output balance.

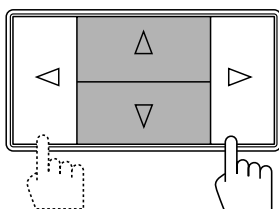
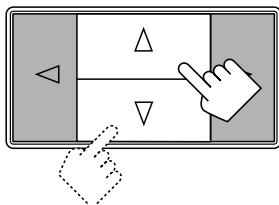
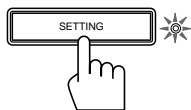

Front panel

On the front panel only:

1. Press **SETTING** so that the Control $\Delta / \nabla / \triangleleft / \triangleright$ buttons work for adjusting the balance.
The lamp next to the button lights up.
2. Press Control Δ / ∇ until **"BALANCE"** appears on the display.
3. Press Control $\triangleleft / \triangleright$ to adjust the balance.
 - Pressing Control \triangleleft decreases the right channel output.
 - Pressing Control \triangleright decreases the left channel output.



See also page 38.

Listening at Low Volume (Loudness)

Human ears are not sensitive to bass at low volume. To compensate for this, the loudness function automatically boosts the bass level as you lower the volume.

Note:

The loudness function affects the front speaker sounds only.

On the front panel only:

1. Press **SETTING** so that the Control $\Delta / \nabla / \triangleleft / \triangleright$ buttons work for setting the loudness function.
The lamp next to the button lights up.
2. Press Control Δ / ∇ until **"LOUDNESS"** appears on the display.
3. Press Control $\triangleleft / \triangleright$ to set the loudness function to **"ON"** or **"OFF."**
 - Select **"ON"** to activate the loudness function.
The **LOUDNESS** indicator lights up on the display.
 - Select **"OFF"** to cancel it.
The indicator goes off.

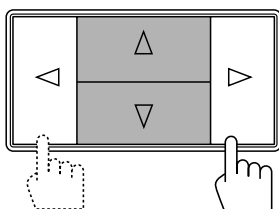
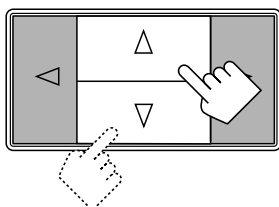
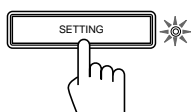

Front panel



Using the Sleep Timer

Using the Sleep Timer, you can fall asleep to music and know the receiver will turn off by itself rather than play all night.

On the front panel *only*:

1. Press **SETTING** so that the Control $\Delta / \nabla / \triangleleft / \triangleright$ buttons work for setting the Sleep Timer

The lamp next to the button lights up.

2. Press Control Δ / ∇ until “<SLEEP>” appears on the display.

3. Press Control $\triangleleft / \triangleright$ to set the shut-off time.

Each time you press the button, the shut-off time on the display changes as follows:

The SLEEP indicator lights up on the display.

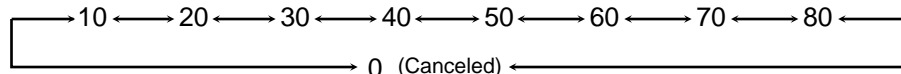

When the shut-off time comes

The receiver turns off automatically.

To check or change the time remaining until the shut-off time

1. Press **SETTING**, if necessary, so that the Control $\Delta / \nabla / \triangleleft / \triangleright$ buttons work for setting the Sleep Timer.

2. Press Control Δ / ∇ , if necessary, until “<SLEEP>” appears on the display.

3. Press Control $\triangleleft / \triangleright$ once.

The remaining time until the shut-off time appears in minutes.

- To change the shut-off time, press Control $\triangleleft / \triangleright$ repeatedly.

To cancel the Sleep Timer

Press Control $\triangleleft / \triangleright$ repeatedly in step 3 above until “0” appears on the display. (The SLEEP indicator goes off.) Turning off the power also cancels the Sleep Timer.

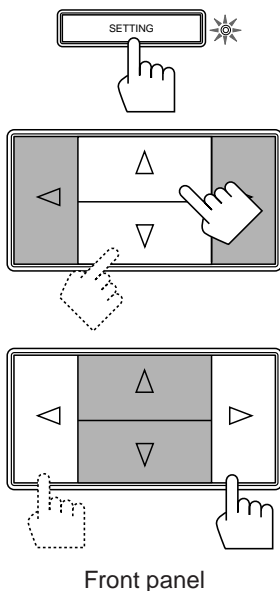

Front panel



Selecting the Center Speaker Size

You can register the information on the center speaker after all connections are completed. If you do this registration first, you do not have to adjust the center speaker mode when you want to activate the surround sound. However, to register the information, first you have to turn on the surround mode. (You cannot select the center speaker size when the surround mode is off.)

On the front panel only:

1. Press **DAP/SURROUND MODE** so that the Control $\triangle / \nabla / \triangleleft / \triangleright$ buttons work for selecting the DAP/surround mode.
The lamp next to the button lights up.
2. Press Control $\triangleleft / \triangleright$ until the **SURROUND** indicator lights up on the display.
3. Press **SETTING** so that the Control $\triangle / \nabla / \triangleleft / \triangleright$ buttons work for selecting the center speaker size.
The lamp next to the button lights up.
4. Press Control \triangle / ∇ until “**CNTR SPK**” (Center Speaker) appears on the display.
5. Press Control $\triangleleft / \triangleright$ to select the appropriate item about your center speaker.
Each time you press the button, the display changes to show the following:

→ LARGE ←
← SMALL →
← NO ←

LARGE:	Select this mode when the size of the center speaker is the same as that of the front speakers.
SMALL:	Select this mode when the size of the center speaker is smaller than that of the front speakers.
NO:	Select this mode when you do not use a center speaker. (You cannot select this mode when “3CHLOGIC” is selected for the surround mode.)

Note:

This center speaker size setting is so related to the center mode setting for the surround mode that changing this setting affects and changes the center mode to a relevant mode, and vice versa.

For example;

- If you select “**LARGE**,” the center mode is automatically set to “**WIDE**,” and vice versa.
- If you select “**SMALL**,” the center mode is automatically set to “**NORMAL**,” and vice versa.
- If you select “**NO**,” the center mode is automatically set to “**PHANTOM**” for Pro Logic and Theater Surround, and vice versa.

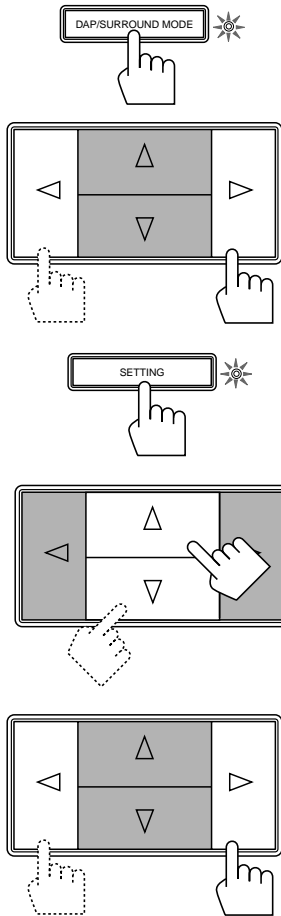

Front panel



Using Visual Confirmation

When you operate the receiver, you can see what you are doing, by showing it on the TV screen. To use this function, you need to connect the TV to the MONITOR OUT jack on the rear panel (see page 9), and set the TV's input mode to the proper position to which the receiver is connected. When the TV's input mode is for TV, you cannot see the on-screen display.

On the front panel only:

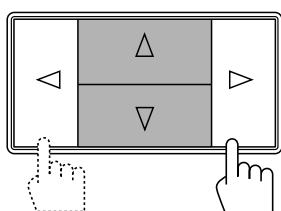
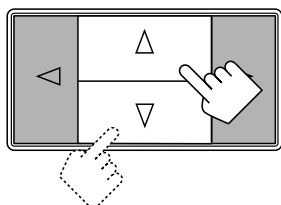
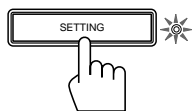

Front panel

1. Press SETTING so that the Control Δ / ∇ / \triangleleft / \triangleright buttons work for setting Visual Confirmation.

The lamp next to the button lights up.

2. Press Control Δ / ∇ until "VCONFIRM" appears on the display.

3. Press Control \triangleleft / \triangleright to set Visual Confirmation to "ON" or "OFF."

- Select "ON" to activate Visual Confirmation. The VISUAL CONFIRMATION indicator lights up on the display.
- Select "OFF" to cancel it. The indicator goes off.

EXAMPLES:

When changing the source:

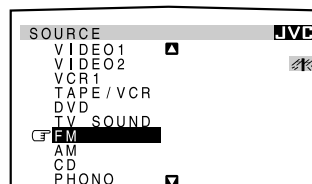

The SOURCE menu appears on the TV screen.

When adjusting the front speaker output balance:

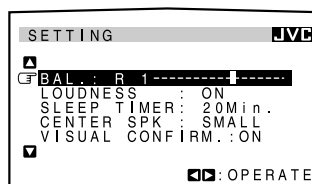

The SETTING menu appears on the TV screen.

When selecting your favorite SEA mode:

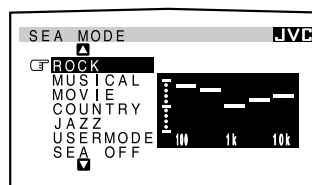

The SEA MODE menu appears on the TV screen.

One Touch Operation

This receiver can memorize the optimum sound settings for each playing source.

About the One Touch Operation

JVC's One Touch Operation function is used to assign and store different sound settings for each different playing source. By using this function, you don't have to change the settings every time you change the source. The stored settings for the newly selected source are automatically recalled.

The following can be stored for each source:

- Volume level (see page 13)
- Balance (see page 15)
- Loudness (see page 15)
- SEA modes (see page 24)
- DAP mode settings (see page 27)
- DVD MULTI playback mode settings (see page 29)
- Surround mode settings (see page 32)

Notes:

- *If the source is FM or AM, the One Touch Operation function works only when the preset channels from 1 — 20 are tuned in. You can assign a different setting for each preset channel.*
- *The DAP mode, DVD MULTI playback mode, and surround mode cannot be used at the same time.*

Using the One Touch Operation



Front panel

On the front panel only:

To store the sound settings

1. Press ONE TOUCH OPERATION.

The ONE TOUCH OPERATION lamp lights up, then the previously memorized settings are recalled and appear on the display in turn.

2. Adjust the sound using the functions listed above.

The newly adjusted settings are memorized.

To recall the sound settings

With the ONE TOUCH OPERATION lamp lit, the settings for the currently selected source is recalled, and appears on the display when the source is selected.

To cancel the One Touch Operation function

Press ONE TOUCH OPERATION so that the lamp goes off.

(Even though the One Touch Operation function is canceled, the recalled sound effects remain active.)

You can browse through all the stations or use the preset function to go immediately to a particular station.



See also page 39.

Tuning in Stations Manually

On the front panel only:

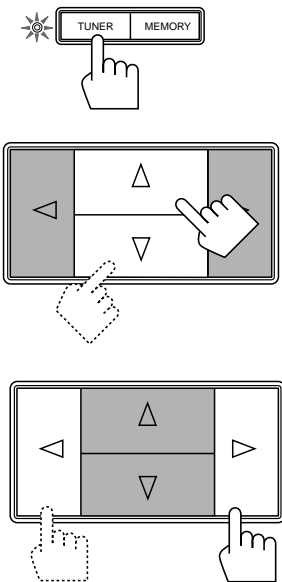

Front panel

1. Press TUNER so that the Control Δ / ∇ / \triangleleft / \triangleright buttons work for tuner settings. The lamp next to the button lights up.
2. Press Control Δ / ∇ until “<FM AM>” appears on the display.
3. Press Control \triangleleft / \triangleright to select the band. Each time you press the button, the band alternates between FM and AM.
4. Press Control Δ / ∇ until “-TUNING+” appears on the display.
5. Press Control \triangleleft / \triangleright until you find the frequency you want.
 - Pressing Control \triangleleft decreases the frequency.
 - Pressing Control \triangleright increases the frequency.

Notes:

- When you hold down Control \triangleleft / \triangleright in step 5, the frequency keeps changing until you press the button again or a station is tuned in.
- When a station of sufficient signal strength is tuned in, the TUNED indicator lights up on the display. When an FM stereo program is received, the STEREO indicator also lights up.



Using Preset Tuning

Once a station is assigned to a channel number, the station can be quickly tuned. You can preset up to 40 stations at random.

To store the preset stations

On the front panel only:

1. Tune in the station you want to preset (see above).

If you want to store the FM reception mode for this station, select the FM reception mode you want. See page 22 for details.

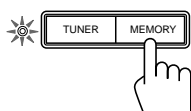

2. Press MEMORY (next to the TUNER button).

“CH-” appears and the channel number position starts flashing on the display for about 5 seconds.

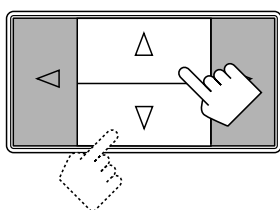

3. Press Control Δ / ∇ to select a channel number while the channel number position is flashing.

- Pressing Control Δ increases the number.
- Pressing Control ∇ decreases the number.

Note:

You can use the 10 keys on the remote control to select the preset number. When using the 10 keys, be sure that they are activated for tuner, not for the CD and others. (See page 44.)

4. Press MEMORY (next the TUNER button) again while the selected channel number is flashing on the display.

The selected channel number stops flashing.
The station is assigned to the selected channel number.

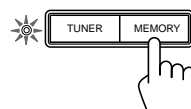

5. Repeat steps 1 to 4 until you store all the stations you want.

Front panel

To cancel a stored preset station

Storing a new station on a used number erases the previously stored one.

CAUTION:

Preset stations may be erased when power is cut off to the receiver, as when it is unplugged from the AC outlet or a power failure occurs. If the preset stations are lost, simply set the stations again.

To tune in a preset station

On the front panel:

1. Press TUNER so that the Control Δ / ∇ / \triangleleft / \triangleright buttons work for tuner settings.

The lamp next to the button lights up.

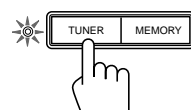

2. Press Control Δ / ∇ until “-PRESET+” appears on the display.

3. Press Control \triangleleft / \triangleright to select a preset channel.

Each time you press the button, the preset channels changes.

- Pressing Control \triangleleft changes preset channels in decreasing order.
- Pressing Control \triangleright changes preset channels in increasing order.

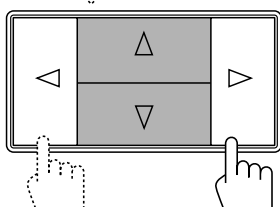
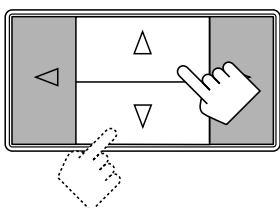

Front panel

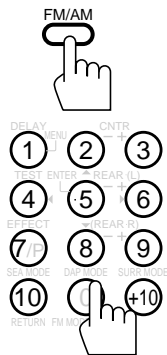

Remote Control

From the remote control:**1. Press FM/AM.**

Each time you press the button, the band alternates between FM and AM.

2. Press 10 keys to select a preset channel number.

- For channel number 5, press 5.
- For channel number 15, press +10 then 5.
- For channel number 20, press +10 then 10.
- For channel number 30, press +10, +10, then 10.

Note:

When you use the 10 keys on the remote control, be sure that they are activated for tuner, not for the CD and others. (See page 44.)

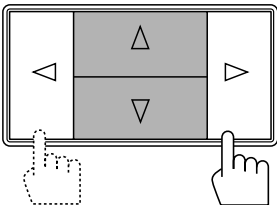
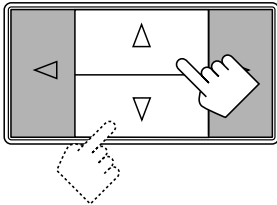
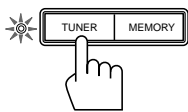

See also
page 39.

Selecting the FM Reception Mode

Front panel



Remote Control

You can change the FM reception mode while listening an FM broadcast.

You can also store the FM reception mode for each preset station. (See page 21.)

On the front panel:**1. Press TUNER so that the Control Δ / ∇ / \triangleleft / \triangleright buttons work for tuner settings.**

The lamp next to the button lights up.

2. Press Control Δ / ∇ until “FM MODE” appears on the display.**3. Press Control \triangleleft / \triangleright to select either “AUTO” or “MONO.”**

- Normally select “AUTO.”
- When an FM stereo broadcast is hard to receive or noisy, select “MONO.”

AUTO:	When a program is broadcast in stereo, you will hear stereo sound; when in monaural, you will hear monaural sounds. This mode is also useful to suppress static noise between stations. The MUTE AUTO indicator lights up on the display.
MONO:	Reception will be improved although you will lose the stereo effect. In this mode, you will hear noise while tuning into the stations. The MUTE AUTO indicator goes off on the display.

From the remote control:**Press FM MODE/MUTING.**

Each time you press the button, “AUTO” and “MONO” is alternately selected, and appears on the display.

Note:

When using the FM MODE/MUTING button, be sure that the 10 keys are activated for tuner, not for the CD and others. (See page 44.)



Assigning Names to Preset Stations

You can assign a name of up to five characters to each preset station (from preset channel number 1 to 20). When a preset station is tuned in, its assigned name will appear on the display.

On the front panel only:

1. Tune in a preset station (preset channel number 1 to 20).

See page 21 for details.

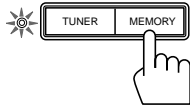

2. Press MEMORY (next to the TUNER button).

The preset channel number starts flashing.

Note:

If you press Control Δ / ∇ while the preset channel number is flashing, you can change the preset channel number.

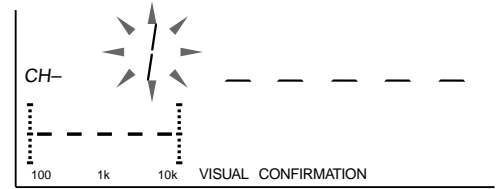

3. Press Control \triangleright (or \triangleleft) until the first character position starts flashing.

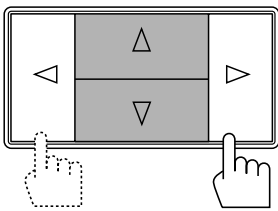
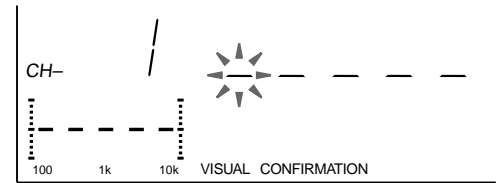

4. Press Control Δ / ∇ to select a character.

You can use characters listed below.

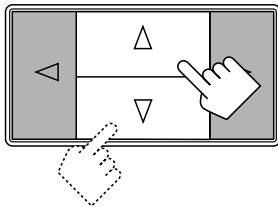
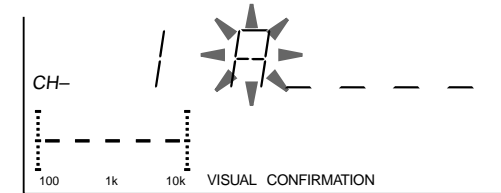

5. When a character you want appears, press

Control \triangleright (or \triangleleft).

The next (or previous) character position starts flashing.

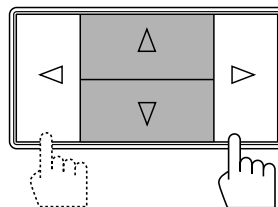
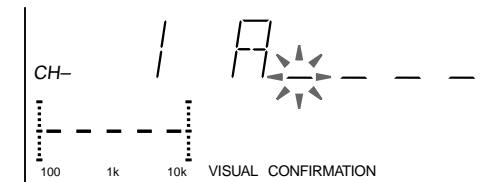

6. Repeat steps 4 and 5 to enter up to five characters.

7. Press MEMORY (next to the TUNER button) again, while the last selected character is flashing, after you have assigned a name.

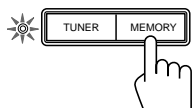

Front panel

To erase the input characters

Insert blanks using the same procedure described above.

Available characters

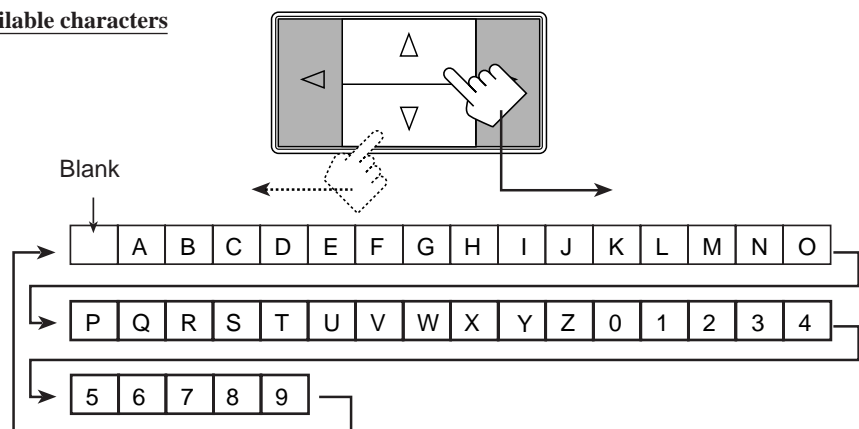

The SEA (Sound Effect Amplifier) modes give you control of the way your music sounds.

Note:
The SEA modes cannot be used for recording.



See also page 39.

Selecting Your Favorite SEA Mode

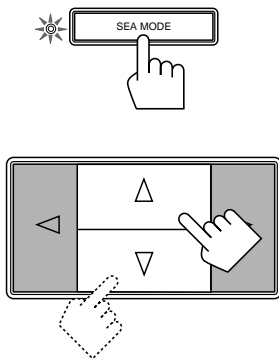

Front panel

On the front panel:

1. Press SEA MODE so that the Control Δ / ∇ buttons work for selecting the SEA mode. The lamp next to the button lights up.
2. Press Control Δ / ∇ until the mode you want appears on the display. Each time you press the button, the SEA mode changes as follows:

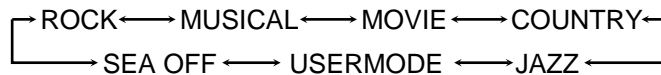

Note:
When the SEA mode is turned on, the SEA indicator lights up on the display.

ROCK:	Gives a heavy sound. Both high and low frequencies are boosted.
MUSICAL:	Enhance the mid-frequency range, which the human voice is mostly made up of.
MOVIE:	Adds breadth to sounds so you feel like you are in a movie theater.
COUNTRY:	Enhances the high-frequency range so that instruments such the violin and banjo are emphasized.
JAZZ:	Gives a feeling of a live atmosphere. Good for acoustic music.
USERMODE:	Your original SEA adjustment (see page 25).
SEA OFF:	No SEA mode is applied (see below).

To cancel the SEA mode, press Control Δ / ∇ until “SEA OFF” appears in step 2 above. The SEA indicator goes off from the display.

From the remote control:

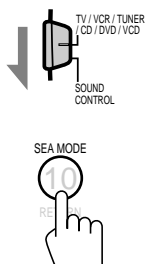

Remote Control

1. Set the remote control mode selector to the “SOUND CONTROL” position. 10 keys are activated for adjusting the sounds.
2. Press the SEA MODE button repeatedly until the SEA mode you want appears on the display. Each time you press the button, the SEA mode changes as follows:

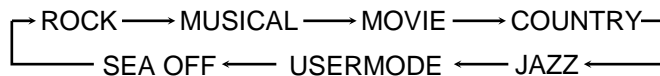

Note:
When the SEA mode is turned on, the SEA indicator lights up on the display.

To cancel the SEA mode, press SEA MODE until “SEA OFF” appears in step 2 above. The SEA indicator goes off from the display.

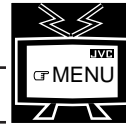

You can adjust and store your own SEA adjustment into memory (USERMODE).

On the front panel only:

If you do not want to store your adjustment, but rather want to adjust the SEA temporarily, skip step 3 below.

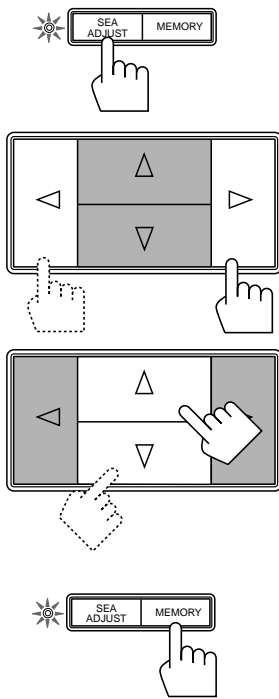

Front panel

1. Press SEA ADJUST so that the Control Δ / ∇ / \triangleleft / \triangleright buttons work for the SEA adjustment.
The lamp next to the button lights up.

2. Adjust the SEA frequency and its level.

- Press Control \triangleleft / \triangleright to select the frequency range to adjust.
- Press Control Δ / ∇ to adjust the level.

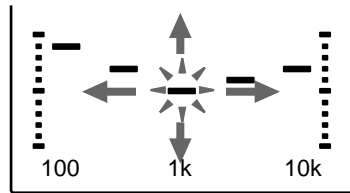

3. Press MEMORY (next to the SEA ADJUST button).
Your adjustment is stored into USERMODE.

To recall your own SEA adjustment

See page 24.

To erase a stored adjustment

Storing a new adjustment into USERMODE erases the previously stored one.

Activating the Surround Sounds

The receiver can reproduce the sounds of the DVD player with its the analog discrete output mode turned on. Moreover, the built-in digital surround processor provides two groups of programs — DAP (Digital Acoustic Processor) modes and surround modes (Dolby Surround and JVC Theater Surround).

You cannot use the DAP mode and surround mode at the same time. When you turn on the DAP mode, the surround mode is turned off (if it has been on), and vice versa.

Notes:

- The digital surround processor has no effect on monaural sources.
- The digital surround processor cannot be used for recording.

On the DAP mode

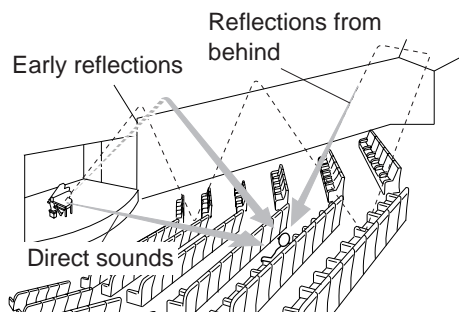

The sound heard in a concert hall or club consists of direct sound and indirect sound — early reflections and reflections from behind. Direct sounds reach the listener directly without any reflection. On the other hand, indirect sounds are delayed by the distances of the ceiling and walls. These direct sounds and indirect sounds are the most important elements of the acoustic surround effects. The DAP mode can create these important elements, and gives you a real “being there” feeling **by using the front speakers and rear speakers.**

On DVD multi playback mode

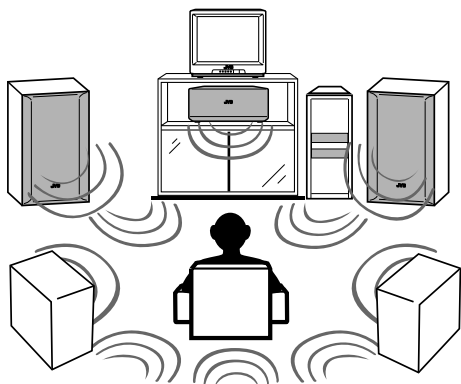

This receiver provides the DVD MULTI playback mode for reproducing the analog discrete output mode of the DVD player.

The soundtracks of the movies are designed to sound best in movie theaters. This means they cannot be reproduced in a home environment as intended by movie-makers. With the introduction of the discrete multi-channel soundtracks of the DVD player, enables dynamic sound experiences of a movie theater in your home in the same way as intended by movie-makers.

To activate the DVD MULTI playback mode, you need to **set the playing mode of the DVD player according to your speaker arrangement.**

On surround mode

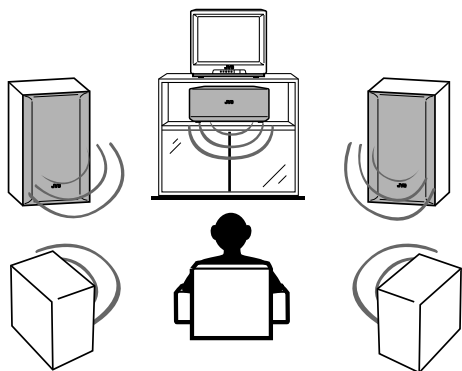

With this receiver, you can use two types of the surround mode.

Dolby Surround

Dolby Surround has been developed to reproduce the important elements of the acoustic surround at home.

To watch the soundtracks of video software bearing the mark  **DOLBY SURROUND** * which includes the same encoded surround information as found in Dolby Stereo films, the receiver can provide you with 2 Dolby Surround modes (Dolby Pro Logic and Dolby 3ch Logic).

Dolby Pro Logic: Select this mode when optional center and rear speakers are connected.

Dolby 3ch Logic: Select this mode when a center speaker is connected without rear speakers.

JVC's Theater (1 and 2) Surround

In order to reproduce a more realistic sound field in your listening room while playing soundtracks of video software bearing the mark  **DOLBY SURROUND**, JVC's Theater Surround has been designed to give you clearer vocals and to create a real “being there” feeling. The sound is reproduced through **the front speakers, rear speakers, and center speaker.**

* Manufactured under license from Dolby Laboratories Licensing Corporation. “Dolby,” the double-D symbol, and “Pro Logic” are trademarks of Dolby Laboratories Licensing Corporation.



You can use five DAP modes — “Dance Club, Live Club, Hall, Pavilion, and Headphones.” These modes (except “Headphones”) require the front speakers and the rear speakers, but do not require a center speaker to enlarge the sound field.

Among the DAP modes, “Headphones” is very special. It can create the same stereo sound as you listen through the speakers off air while listening to a source using headphones. So, you can feel as if you were not using the headphones and listening to music in a room.

Note:

When you select “DVDMULTI” as the source to play, you cannot select the DAP mode.

On the front panel:

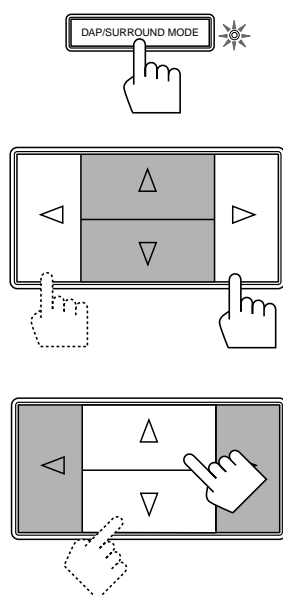

Front panel

1. Press **DAP/SURROUND MODE** so that the Control $\triangle / \nabla / \triangleleft / \triangleright$ buttons work for selecting the DAP/surround modes.

The lamp next to the button lights up.

2. Press Control $\triangleleft / \triangleright$ to select the DAP mode.

The DAP indicator lights up on the display.

Each time you press the button, the DAP and surround modes alternately comes into effect.

3. Press Control \triangle / ∇ until the DAP mode you want appears on the display.

Each time you press the button, the DAP modes change as follows:

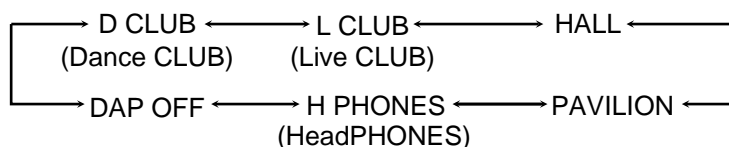

Dance CLUB:	Gives a throbbing bass beat.
Live CLUB:	Gives the feeling of a live music club with a low ceiling.
HALL:	Gives clear vocal and the feeling of a concert hall.
PAVILION:	Gives the spacious feeling of a pavilion with a high ceiling.
HeadPHONES*:	Gives a spacious stereo effect when listening with headphones.
DAP OFF:	No DAP mode is applied.

Note:

When you select “Headphones” (the «H.PHONE» indicator lights up), you cannot adjust the rear speaker output level in the following steps.

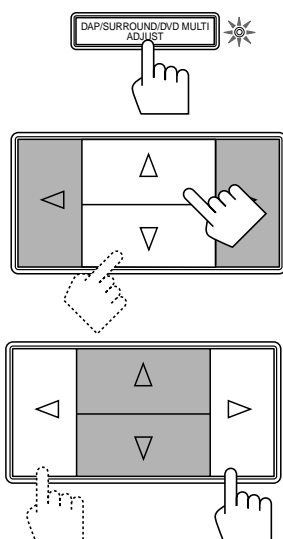

Front panel

4. Press **DAP/SURROUND/DVD MULTI ADJUST** so that the Control $\triangle / \nabla / \triangleleft / \triangleright$ buttons work for adjusting the selected mode.

The lamp next to the button lights up.

5. Press Control \triangle / ∇ until “- REAR +” appears on the display.

6. Press Control $\triangleleft / \triangleright$ to adjust the rear speaker output level.

- Pressing Control \triangleleft decreases the output level up to -10 dB.
- Pressing Control \triangleright increases the output level up to +10 dB.

Note:

You cannot adjust the left and right rear speaker output level separately.

7. Press Control \triangle / ∇ until “-EFFECT+” appears on the display.

8. Press Control $\triangleleft / \triangleright$ to adjust the effect level.

Each time you press the button, the effect level changes as follows:

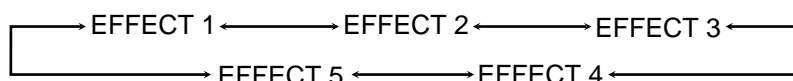

As the number increases, the selected DAP mode becomes stronger.

Note:

When you select “Headphones” (the «H.PHONE» indicator lights up), you cannot select “EFFECT 5.”

To cancel the DAP mode, press Control \triangle / ∇ until “DAP OFF” appears in step 3 above. The DAP indicator goes off from the display.

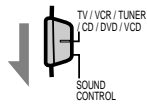

From the remote control:

- 1. Set the remote control mode selector to the “SOUND CONTROL” position.**
10 keys are activated for adjusting the sounds.
- 2. Press DAP MODE until the DAP mode you want appears on the display.**
The DAP indicator also lights up on the display.
Each time you press the button, the DAP modes change as follows:

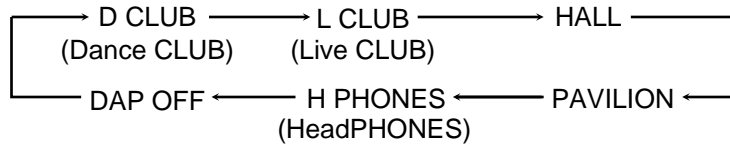

Note:

When you select “Headphones” (the «H.PHONE» indicator lights up), you cannot adjust the rear speaker output level in the following steps.

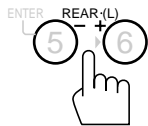

- 3. Press REAR•(L) +/- to adjust the rear speaker output level.**
 - Pressing REAR•(L) – decreases the output level up to –10 dB.
 - Pressing REAR•(L) + increases the output level up to +10 dB.

Note:

You cannot adjust the left and right rear speaker output level separately.



Remote Control

- 4. Press EFFECT to adjust the effect level.**
Each time you press the button, the effect level changes as follows:

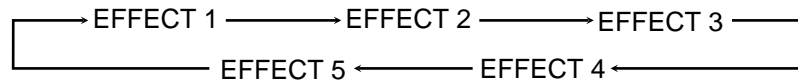

As the number increases, the selected DAP mode becomes stronger.

Note:

When you select “Headphones” (the «H.PHONE» indicator lights up), you cannot select “EFFECT 5.”

To cancel the DAP mode, press DAP MODE until “DAP OFF” appears in step 2 above.
The DAP indicator goes off from the display.



Using the DVD MULTI Playback Mode

This receiver provides the DVD MULTI playback mode for reproducing the analog discrete output mode of the DVD player.

Before playing back a DVD, refer also to the manual supplied with the DVD player.

Speaker arrangements for DVD MULTI playback

The following illustrations show how to obtain the optimum sound environment for the DVD MULTI playback mode. Try to find the speaker direction and location to create the optimum sound field.

When you play back a disc on the DVD player with its analog discrete output mode selected:

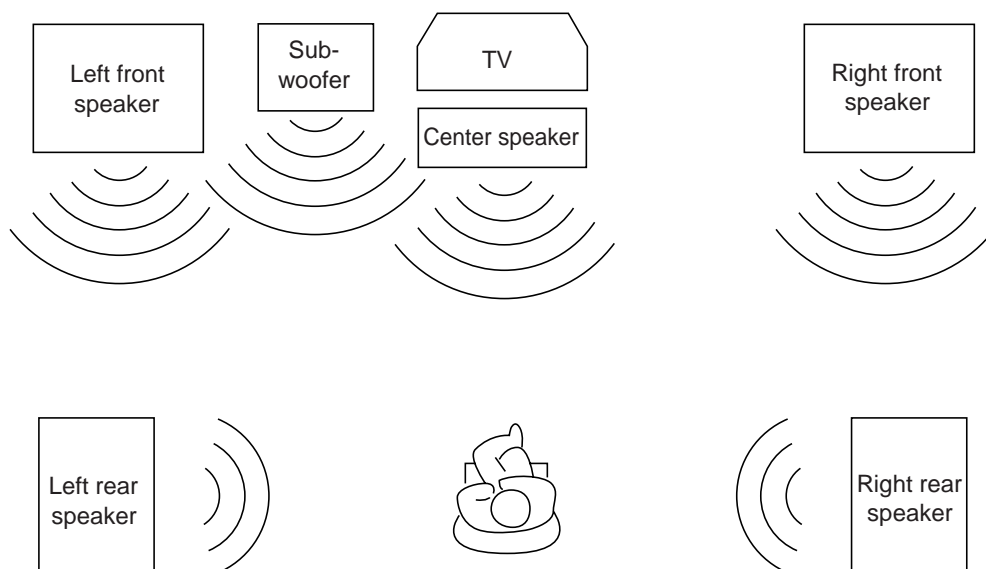

Activating the DVD MULTI playback

You can adjust the DVD MULTI playback mode while playing back a DVD using the analog discrete output mode on the DVD player.

Once you made adjustments, the receiver memorizes the adjustments until you change them. You also need to set the DVD player to the analog discrete output mode.

Note:

When you select "DVMULTI" as the source to play, the DAP and surround modes are canceled temporarily.



On the front panel:

1. Press DVD MULTI so that "DVMULTI" appears on the display.
The lamp above the button and the DVD lamp (of the source lamps) light up.
2. Select the analog discrete output mode on the DVD player, and start playing a DVD.
Refer to the manual supplied with the DVD player.

If you want to make any adjustment, go to the following steps.

3. Press DAP/SURROUND/DVD MULTI ADJUST so that the Control Δ / ∇ / \triangleleft / \triangleright buttons work for adjusting the DVD MULTI playback mode.
The lamp next to the button lights up.
4. Press Control Δ / ∇ until "-CENTER+" appears on the display.

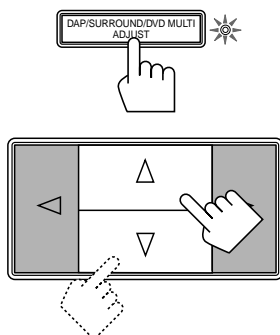

Front panel

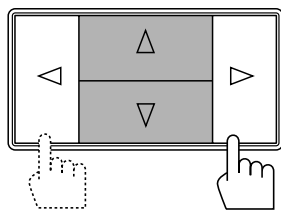
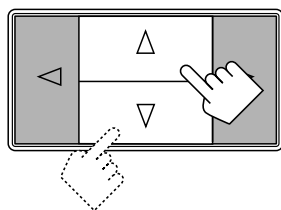
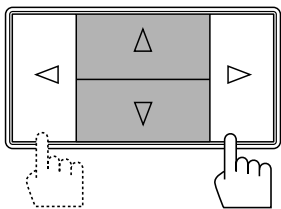

Front panel

5. Press Control </> to adjust the center speaker output level.

- Pressing Control </> decreases the output level up to -10 dB.
- Pressing Control >/> increases the output level up to +10 dB.

6. Press Control Δ/▽ until “-REAR L+” appears on the display.

7. Press Control </> to adjust the left rear speaker output level.

- Pressing Control </> decreases the output level up to -10 dB.
- Pressing Control >/> increases the output level up to +10 dB.

8. Press Control Δ/▽ until “-REAR R+” appears on the display.

9. Press Control </> to adjust the right rear speaker output level.

- Pressing Control </> decreases the output level up to -10 dB.
- Pressing Control >/> increases the output level up to +10 dB.

10. Press Control Δ/▽ until “CNT TONE” (Center Tone) appears on the display.

11. Press Control </> to select the center tone you want.

The center tone adjustment affects the mid-frequency range, which the human voice is mostly made up of.

Each time you press the button, the display changes to show the following:

SOFT2 ↔ SOFT1 ↔ FLAT ↔ SHARP1 ↔ SHARP2

To make the dialogue clearer, select “SHARP1” (little) or “SHARP2” (much).

To make the dialogue softer, select “SOFT1” (little) or “SOFT2” (much).

When “FLAT” is selected, no adjustment is applied.

From the remote control:

Note:

If you want to use the remote control for adjusting the center tone, use the menu function (see page 39).



1. Press DVD MULTI so that “DVMULTI” appears on the display.

The DVD MULTI lamp lights up and the DVD lamp (of the source lamps) lights up.

2. Select the analog discrete output mode on the DVD player, and start playing a DVD.

Refer to the manual supplied with the DVD player.

If you want to make any adjustment, go to the following steps.

3. Set the remote control mode selector to the “SOUND CONTROL” position.

10 keys are activated for adjusting the sounds.

4. Press CNTR +/- to adjust the center speaker output level.

- Pressing CNTR - decreases the output level up to -10 dB.
- Pressing CNTR + increases the output level up to +10 dB.

5. Press REAR•(L) +/- to adjust the left rear speaker output level.

- Pressing REAR•(L) - decreases the output level up to -10 dB.
- Pressing REAR•(L) + increases the output level up to +10 dB.

6. Press (REAR•R) +/- to adjust the right rear speaker output level.

- Pressing (REAR•R) - decreases the output level up to -10 dB.
- Pressing (REAR•R) + increases the output level up to +10 dB.

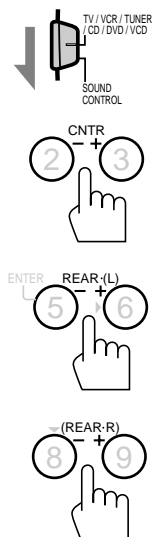

Remote Control



Using the Surround Modes

With this receiver, you can use two types of the surround mode — Dolby Surround and JVC Theater Surround

Speaker arrangements for surround mode

The following illustrations show how to obtain the optimum sound environment for surround modes. Try to find the speaker direction and location to create the optimum sound field.

CASE 1 When you have added a center speaker and rear speakers

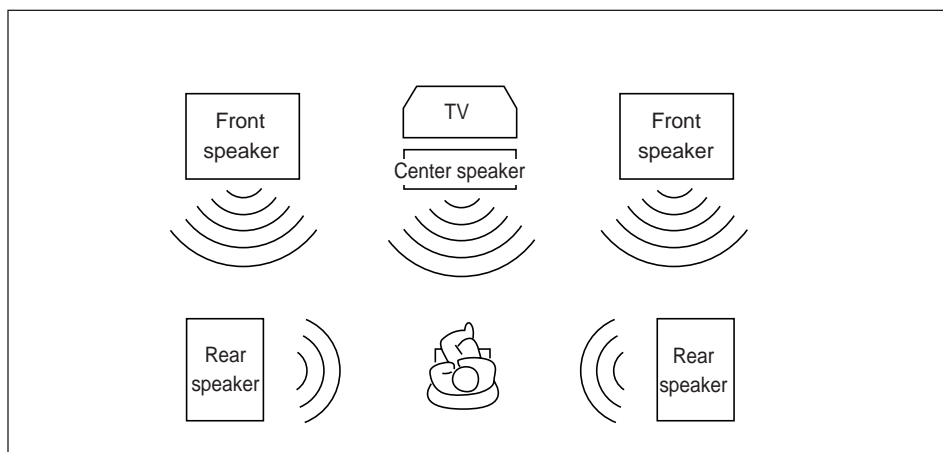

In this case:

1. Select “PROLOGIC,” “THEATER1” or “THEATER2.”
2. Select “NORMAL” or “WIDE” for center mode.

See pages 32 to 35 for more details.

CASE 2 When you have added rear speakers (without a center speaker)

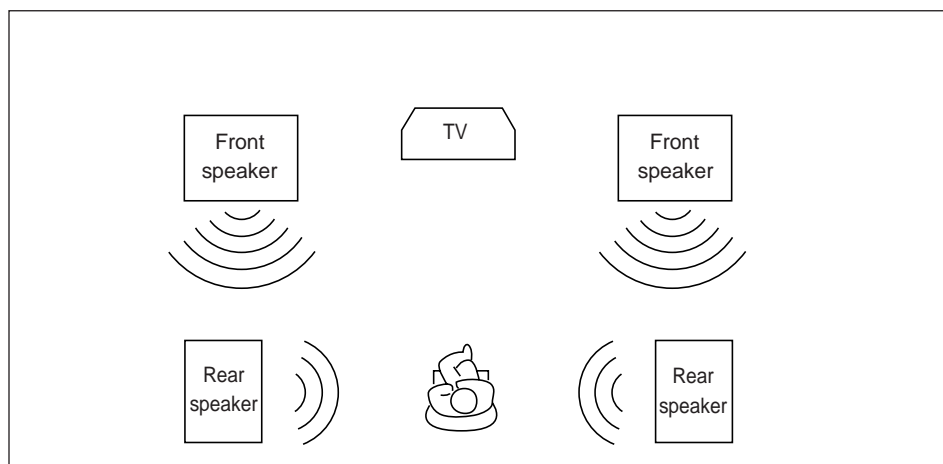

In this case:

1. Select “PROLOGIC,” “THEATER1” or “THEATER2.”
2. Select “PHANTOM” for center mode.

See pages 32 to 35 for more details.

CASE 3 When you have added a center speaker (without rear speakers)

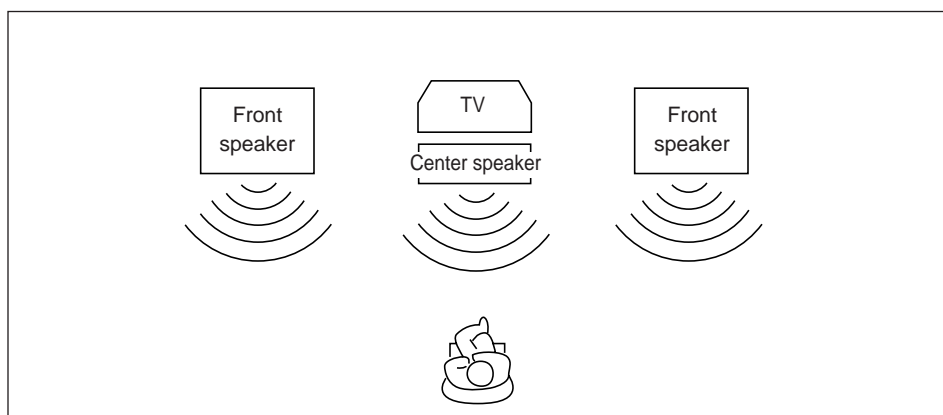

In this case:

1. Select “3CHLOGIC.”
2. Select “NORMAL” or “WIDE” for center mode.

See pages 32 to 35 for more details.

Preparing for the surround mode

Once you have set the surround modes, you can use the same adjustment every time you want to activate the surround you want. The receiver memorizes surround adjustments for each mode.

Note:

When you select "DVDMULTI" as the source to play, you cannot select or adjust the surround mode.

On the front panel:

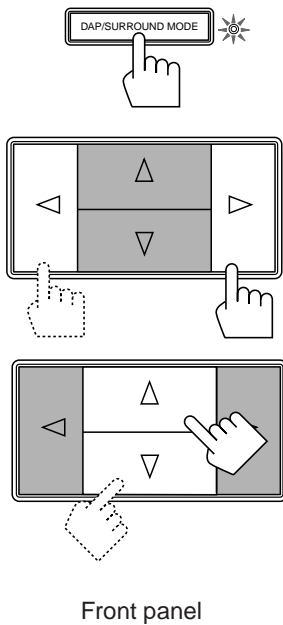

1. **Press DAP/SURROUND MODE so that the Control Δ / ∇ / \triangleleft / \triangleright buttons work for selecting the DAP/surround modes.**
The lamp next to the button lights up.
2. **Press Control \triangleleft / \triangleright to select the surround mode.**
The SURROUND indicator lights up on the display.
Each time you press the button, the DAP and surround modes alternately come into effect.
3. **Press Control Δ / ∇ until the surround mode you want appears on the display.**
Each time you press the button, the surround modes change as follows (the indicator of the selected surround mode also lights up on the display):

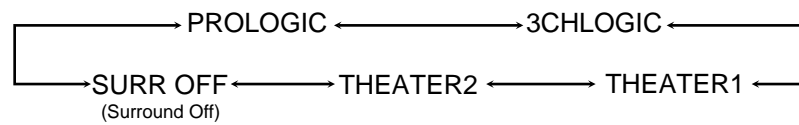

PROLOGIC:	Select this mode to watch a video source with Dolby Surround when you have connected the rear speakers (and a center speaker).
3CHLOGIC:	Select this mode to watch a video source with Dolby Surround when you have connected a center speaker and no rear speakers.
THEATER1:	Select this mode to watch a video source with Dolby Surround when you have connected the rear speakers (and a center speaker). This mode gives you the feeling of a small movie theater with a seating capacity of 100.
THEATER2:	Select this mode to watch a video source with Dolby Surround when you have connected the rear speakers (and a center speaker). This mode gives you the feeling of a large movie theater with a seating capacity of 1000.
SURR OFF:	No surround mode is applied.



4. **Press DAP/SURROUND/DVD MULTI ADJUST so that the Control Δ / ∇ / \triangleleft / \triangleright buttons work for adjusting the surround mode.**
The lamp next to the button lights up.

To be continued to the next page

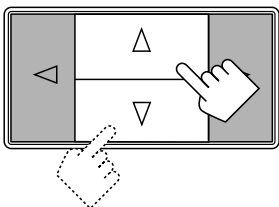

5. Press Control Δ / ∇ until “CNT MODE” (Center Mode) appears on the display.

6. Press Control $\triangleleft / \triangleright$ to select the center mode.

Each time you press the button, the center modes change as follows:

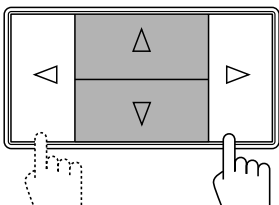
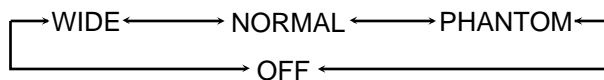

WIDE:	Select this mode when the center speaker can reproduce the bass better than the front speakers. All signals of the center channel are output through the center speaker.
NORMAL:	Select this mode when the center speaker cannot reproduce the bass better than the front speakers. The bass portions of the center channel signals are output through the front speakers.
PHANTOM:	Select this mode when you do not use a center speaker. The center speaker channel signals are output through the front speakers.
OFF:	Select this mode to turn off the center speaker channel.

Notes:

- If you have already set the “center speaker size” following the procedure described on page 17, you do not have to select the center mode in this procedure.
- When you have selected “3CHLOGIC,” you cannot select “PHANTOM.”

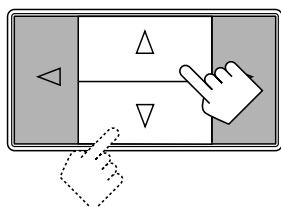

7. Press Control Δ / ∇ until “-DELAY +” appears on the display.

8. Press Control $\triangleleft / \triangleright$ to adjust the delay time of the rear speaker output.

Each time you press the button, the delay time changes as follows:

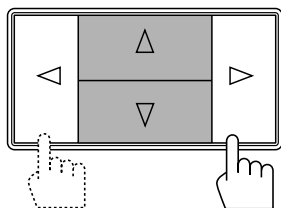
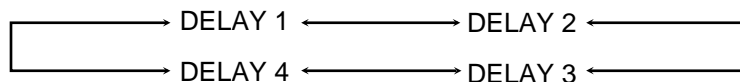

DELAY 1:	Select this when the distance from you to your rear speakers is greater than that to the front speakers.
DELAY 2:	Select this when the distance from you to your rear speakers is almost equal to that to the front speakers.
DELAY 3:	Select this when the distance from you to your rear speakers is a little less than that to the front speakers.
DELAY 4:	Select this when the distance from you to your rear speakers is much less than that to the front speakers.

Note:

When you have selected “3CHLOGIC,” you cannot adjust the delay time.

9. Press Control Δ / ∇ until “TEST” appears on the display, then press Control $\triangleleft / \triangleright$ to start checking the speaker output balance.

“TEST” starts flashing on the display, and a test tone comes out of the speakers in the following order:

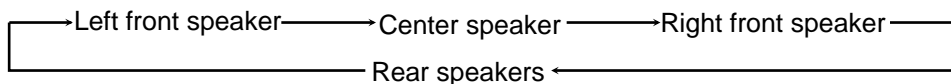

Notes:

- No test tone comes out of the rear speakers when you have selected “3CHLOGIC.”
- No test tone comes out of the center speaker when you select “PHANTOM” or “OFF” for the center mode.

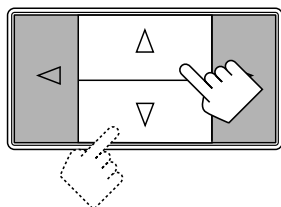

Front panel

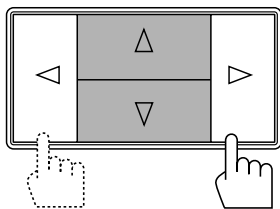
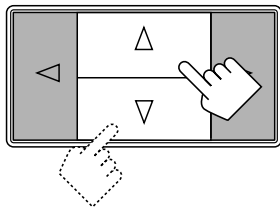

Front panel

10. If necessary, adjust the speaker output level as follows:

- To adjust the rear speaker output level, press Control Δ / ∇ until “- REAR +” appears on the display, then press Control $\triangleleft / \triangleright$.
- To adjust the center speaker output level, press Control Δ / ∇ until “-CENTER+” appears on the display, then press Control $\triangleleft / \triangleright$.

Notes:

- You cannot adjust the left and right rear speaker output level separately.
- You cannot adjust the rear speaker output level when you have selected “3CHLOGIC.”
- You cannot adjust the center speaker output level when you select “PHANTOM” or “OFF” for the center mode.

11. Press Control Δ / ∇ until “TEST” appears on the display, then press Control $\triangleleft / \triangleright$ to stop the test tone.**12. Press Control Δ / ∇ until “CNT TONE” (Center Tone) appears on the display.****13. Press Control $\triangleleft / \triangleright$ to select the center tone you want.**

The center tone adjustment affects the mid-frequency range, which the human voice is mostly made up of.

Each time you press the button, the display changes to show the following:

SOFT2 \longleftrightarrow SOFT1 \longleftrightarrow FLAT \longleftrightarrow SHARP1 \longleftrightarrow SHARP2

To make the dialogue clearer, select “SHARP1” (little) or “SHARP2” (much).

To make the dialogue softer, select “SOFT1” (little) or “SOFT2” (much).

When “FLAT” is selected, no adjustment is applied.

Note:

The center tone cannot be adjusted when sounds do not come out of the center speaker.

If you have selected the JVC Theater Surround, go to the following steps.

14. Press Control Δ / ∇ until “-EFFECT+” appears on the display.**15. Press Control $\triangleleft / \triangleright$ to adjust the effect level.**

Each time you press the button, the effect level changes as follows:

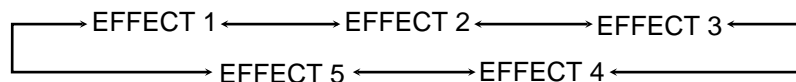

As the number increases, the surround mode becomes stronger.

Note:

When you have selected Dolby Surround, you cannot select the effect level.

From the remote control:**Note:**

If you want to use the remote control for adjusting the center mode and the center tone, use the menu function (see page 40).

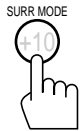
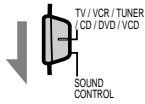
**1. Set the remote control mode selector to the “SOUND CONTROL” position.**

10 keys are activated for adjusting the sounds.

2. Press SURR MODE until the surround mode you want appears on the display.

The SURROUND indicator also lights up on the display.

Each time you press the button, the surround modes change as follows (the indicator of the selected surround mode also lights up on the display):

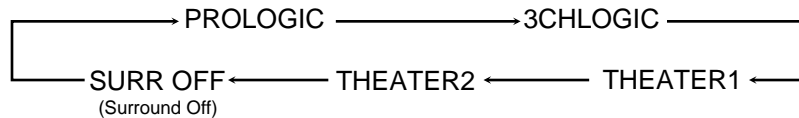
**3. Press DELAY to adjust the delay time of the rear speaker output.**

Each time you press the button, the delay time changes as follows:

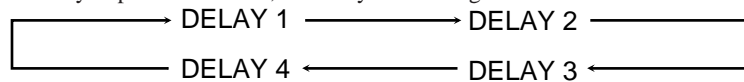
**Note:**

When you have selected “3CHLOGIC,” you cannot adjust the delay time.

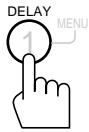
**4. Press TEST to start checking the speaker output balance.**

“TEST” starts flashing on the display, and a test tone comes out of the speakers in the following order:

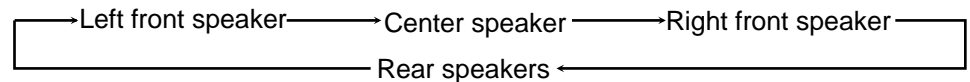
**Notes:**

- No test tone comes out of the rear speakers when you have selected “3CHLOGIC.”
- No test tone comes out of the center speaker when you select “PHANTOM” or “OFF” for the center mode.

**5. If necessary, adjust the speaker output level as follows:**

- To adjust the rear speaker output level, press REAR•(L) +/-.
- To adjust the center speaker output level, press CNTR +/-.

Pressing – decreases the output level up to –10 dB.

Pressing + increases the output level up to +10 dB.

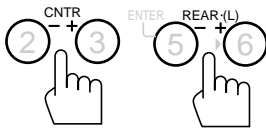
**Notes:**

- You cannot adjust the left and right rear speaker output level separately.
- You cannot adjust the rear speaker output level when you have selected “3CHLOGIC.”
- You cannot adjust the center speaker output level when you select “PHANTOM” or “OFF” for the center mode.

6. Press TEST again to stop the test tone.

If you have selected the JVC Theater Surround, go to the following steps.

7. Press EFFECT to adjust the effect level.

Each time you press the button, the effect level changes as follows:

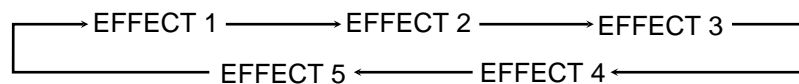

As the number increases, the surround mode becomes stronger.

Note:

When you have selected Dolby Surround, you cannot select the effect level.



Remote Control

Activating the surround modes

Once you have set the surround modes, you can use the same adjustment every time you want to enjoy the surround you want. The receiver memorizes surround adjustments for each mode.

Note:

When you select "DVDMULTI" as the source to play, the surround mode is canceled temporarily.

On the front panel:

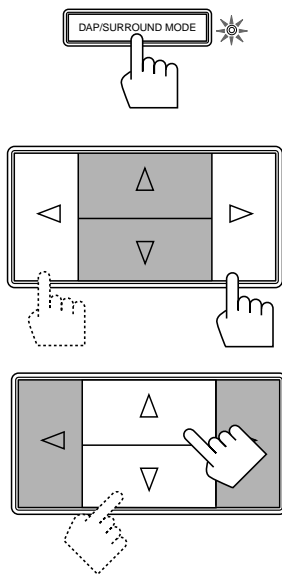

Front panel

1. Press **DAP/SURROUND MODE** so that the Control $\Delta / \nabla / \triangleleft / \triangleright$ buttons work for selecting the DAP/surround modes.

The lamp next to the button lights up.

2. Press Control $\triangleleft / \triangleright$ to select the surround mode.

The SURROUND indicator lights up on the display.

Each time you press the button, the DAP and surround modes alternately come into effect.

3. Press Control Δ / ∇ until the surround mode you want appears on the display.

Each time you press the button, the surround modes change as follows (the indicator of the selected surround mode also lights up on the display):

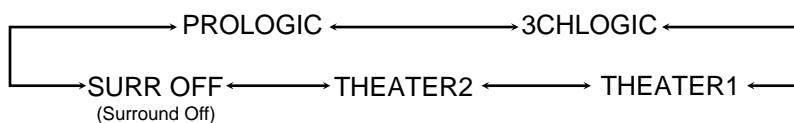

4. Select and play a sound source which was processed with Dolby Surround and is labeled with  mark.

To cancel the surround mode, press Control Δ / ∇ until "SURR OFF" appears in step 3 above.

The SURROUND indicator and the indicator of the selected surround mode goes off from the display.

From the remote control:

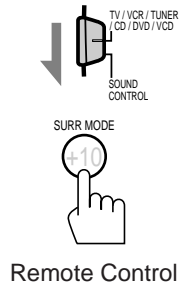

Remote Control

1. Set the remote control mode selector to the "SOUND CONTROL" position.

10 keys are activated for adjusting the sounds.

2. Press **SURR MODE** until the surround mode you want appears on the display.

The SURROUND indicator also lights up on the display.

Each time you press the button, the surround modes change as follows (the indicator of the selected surround mode also lights up on the display):

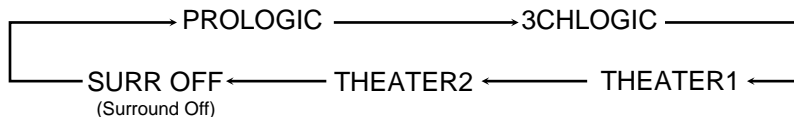

3. Select and play a sound source which was processed with Dolby Surround and is labeled with  mark.

To cancel the surround mode, press SURR MODE until "SURR OFF" appears in step 2 above.

The SURROUND indicator and the indicator of the selected surround mode goes off from the display.

Using the On-Screen Display to Control the Receiver

You can use the menu function on the TV screen to control the receiver.

To use this function, you need to connect the TV to the MONITOR OUT jack on the rear panel (see page 9), and set the TV's input mode to the appropriate position to which the receiver is connected.

When the TV's input mode is for TV, you cannot see the on-screen display.

IMPORTANT

When you use the menu functions, make sure that you have connected a TV and operate the menu function while watching the on-screen displays on the TV.

Note:

If your TV is not of the PAL color system, the TV screen will be distorted.

Basic Procedures

Menu function buttons

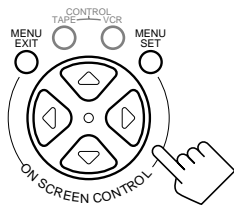

MAIN MENU

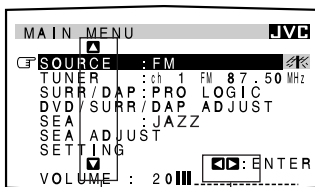

Shows the buttons you can use on the current menu. In this case, press Δ / ∇ to move \square up and down, and \triangleleft / \triangleright to select the item.

From the remote control:

1. Press MENU SET.

The MAIN MENU appears on the TV screen.

- If you press Δ / ∇ / \triangleleft / \triangleright , a sub-menu you can adjust at that time appears on the TV screen instead of the MAIN MENU.

2. Press Δ / ∇ to move \square to the sub-menu you want to set, then press \triangleleft / \triangleright .

The sub-menu you want appears.

3. If necessary, press Δ / ∇ / \triangleleft / \triangleright to set or adjust the item you want on the selected sub-menu.

When a item is selected, the item will be highlighted.

Note:

Moving \square to an item does not mean that you have selected it. If the item is not highlighted, press \triangleleft / \triangleright to highlight it.

4. When you finish, press MENU EXIT.

The menu disappears from the TV.

To go back to the MAIN MENU any time during the process

Press MENU SET again.

Selecting the Source to Play (Also see page 12)

1. Press MENU SET.

The MAIN MENU appears on the TV.

2. Press Δ / ∇ to move \square to "SOURCE," then press \triangleleft / \triangleright .

The SOURCE menu appears.

3. Press Δ / ∇ to move \square to the source you want to play.

To select the DVD MULTI playback mode, press \triangleleft / \triangleright while "DVD" is selected as the source.

4. When you finish, press MENU EXIT.

The menu disappears from the TV.

SOURCE menu

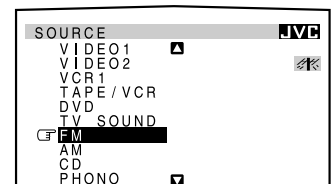

Adjusting the Front Speaker Output Balance (Also see page 15)

1. Press MENU SET.

The MAIN MENU appears on the TV.

2. Press Δ / ∇ to move \square to "SETTING," then press \triangleleft / \triangleright .

The SETTING menu appears.

3. Press Δ / ∇ to move \square to "BAL." (Balance).

4. Press \triangleleft / \triangleright repeatedly to adjust the balance.

5. When you finish, press MENU EXIT.

The menu disappears from the TV.

SETTING menu

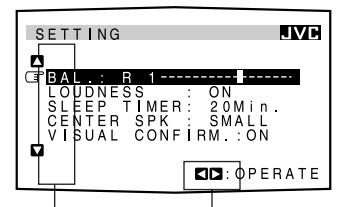

Shows the buttons you can use on the current menu.

In this case, press Δ / ∇ to move \square up and down, and \triangleleft / \triangleright to adjust or set the item.

■ Listening at Low Volume (Loudness) (Also see page 15)

1. Press **MENU SET**.
The MAIN MENU appears on the TV.
2. Press Δ / ∇ to move \square to "SETTING," then press $\triangle / \triangleright$.
The SETTING menu appears.
3. Press Δ / ∇ to move \square to "LOUDNESS."
4. Press $\triangle / \triangleright$ to set the loudness function to "ON" or "OFF."
5. When you finish, press **MENU EXIT**.
The menu disappears from the TV.

SETTING menu

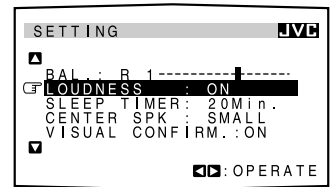

■ Using the Sleep Timer (Also see page 16)

1. Press **MENU SET**.
The MAIN MENU appears on the TV.
2. Press Δ / ∇ to move \square to "SETTING," then press $\triangle / \triangleright$.
The SETTING menu appears.
3. Press Δ / ∇ to move \square to "SLEEP TIMER."
4. Press $\triangle / \triangleright$ to set the shut-off time.
5. When you finish, press **MENU EXIT**.
The menu disappears from the TV.

SETTING menu

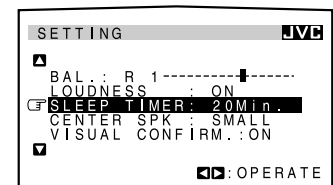

■ Selecting the Center Speaker Size (Also see page 17)

Note:

When the surround mode is off, you cannot select the center speaker size.

1. Press **MENU SET**.
The MAIN MENU appears on the TV.
2. Press Δ / ∇ to move \square to "SETTING," then press $\triangle / \triangleright$.
The SETTING menu appears.
3. Press Δ / ∇ to move \square to "CENTER SPK" (Center Speaker).
4. Press $\triangle / \triangleright$ repeatedly until the appropriate center speaker size is selected.
5. When you finish, press **MENU EXIT**.
The menu disappears from the TV.

SETTING menu

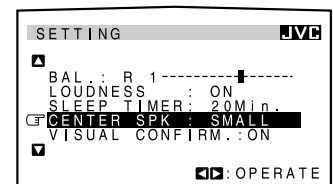

■ Using Visual Confirmation (Also see page 18)

1. Press **MENU SET**.
The MAIN MENU appears on the TV.
2. Press Δ / ∇ to move \square to "SETTING," then press $\triangle / \triangleright$.
The SETTING menu appears.
3. Press Δ / ∇ to move \square to "VISUAL CONFIRM." (Visual Confirmation).
4. Press $\triangle / \triangleright$ to set Visual Confirmation to "ON" or "OFF."
5. When you finish, press **MENU EXIT**.
The menu disappears from the TV.

SETTING menu

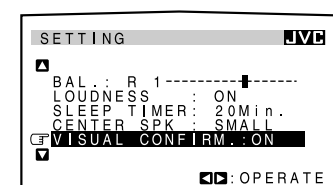

Operating the Tuner

1. **Press MENU SET.**
The MAIN MENU appears on the TV.
2. **Press Δ / ∇ to move \square to "TUNER," then press \triangleleft / \triangleright .**
The TUNER menu appears.
3. **Press Δ / ∇ to move \square to the item you want to set or adjust, then press \triangleleft / \triangleright .**
On the TUNER menu, you can do the following:
 - "CH.": Select a preset channel station. (See page 21)
If you want to assign a name to a preset channel, see page 23.
 - "BAND": Select the band. (See page 20)
 - "TUNING": Tune in a station manually. (See page 20)
 - "FM MODE": Select the FM reception mode. (See page 22)
4. **When you finish, press MENU EXIT.**
The menu disappears from the TV.

TUNER menu

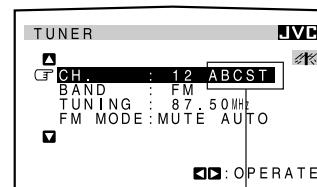

If you have assigned the name to this preset station, it appears here.

Selecting Your Favorite SEA Mode (Also see page 24)

1. **Press MENU SET.**
The MAIN MENU appears on the TV.
2. **Press Δ / ∇ to move \square to "SEA," then press \triangleleft / \triangleright .**
The SEA MODE menu appears.
3. **Press Δ / ∇ to move \square to the SEA mode you want.**
4. **When you finish, press MENU EXIT.**
The menu disappears from the TV.

SEA MODE menu

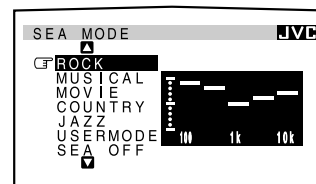

Creating Your Own SEA Mode (Also see page 25)

1. **Press MENU SET.**
The MAIN MENU appears on the TV.
2. **Press Δ / ∇ to move \square to "SEA ADJUST" then press \triangleleft / \triangleright .**
The SEA ADJUST menu appears.
3. **Press Δ / ∇ / \triangleleft / \triangleright to adjust the SEA mode as you want.**
 \triangleleft / \triangleright : Select the frequency ranges.
 Δ / ∇ : Adjust the frequency levels.
4. **Press MEMORY (next to the SEA ADJUST button).**
5. **When you finish, press MENU EXIT.**
The menu disappears from the TV.

SEA ADJUST menu

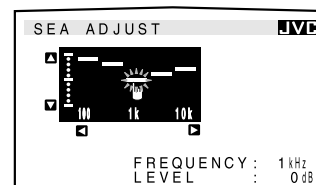

Adjusting the DVD MULTI Playback Mode (Also see page 29)

Before adjusting the DVD MULTI playback mode, you have to select "DVDMULTI" as the source to play.

1. **Press MENU SET.**
The MAIN MENU appears on the TV.
2. **Press Δ / ∇ to move \square to "DVD/SURR/DAP ADJUST," then press \triangleleft / \triangleright .**
The DVD MULTI menu appears.
3. **Press Δ / ∇ to move \square to the item you want to set or adjust, then press \triangleleft / \triangleright .**
On the DVD MULTI adjustment menu, you can do the following:
 - "CENTER": Adjust the center speaker output level.
 - "REAR L": Adjust the left rear speaker output level.
 - "REAR R": Adjust the right rear speaker output level.
 - "CENTER TONE": Select the center tone.
4. **When you finish, press MENU EXIT.**
The menu disappears from the TV.

DVD MULTI adjustment menu

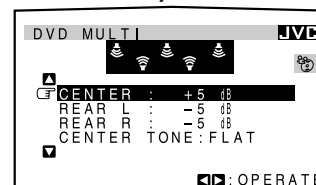

Selecting the DAP or Surround Modes (Also see pages 27 and 31)

Note:

When the source is "DVIDMULTI", you cannot select the DAP or the surround mode.

1. **Press MENU SET.**
The MAIN MENU appears on the TV.
2. **Press Δ / ∇ to move \leftarrow to "SURR/DAP," then press \triangleleft / \triangleright .**
The DAP or SURROUND menu (previously selected mode) appears.
3. **Press \triangleleft / \triangleright to select either the surround or DAP mode.**
The DAP MODE menu or SURROUND MODE menu appears.
4. **Press Δ / ∇ to move \leftarrow to one of the DAP modes or surround modes.**

If you want to adjust the selected mode, go to the following steps.

5. **Press MENU SET.**
The MAIN MENU appears on the TV again.
6. **Press Δ / ∇ to move \leftarrow to "DVD/SURR/DAP ADJUST," then press \triangleleft / \triangleright .**
The adjustment menu for the mode you have selected in step 4 appears.
7. **Press Δ / ∇ to move \leftarrow to the item you want to set or adjust, then press \triangleleft / \triangleright .**
On these adjustment menus, you can do the following:

For Dolby Pro Logic:

- "CENTER MODE": Select the center mode.
- "TEST": Output a test tone.
- "CENTER": Adjust the center speaker output level.
- "REAR": Adjust the rear speaker output level.
- "DELAY": Adjust the delay time of the rear speaker sound.
- "CENTER TONE": Select the center tone.

For Dolby 3ch Logic:

- "CENTER MODE": Select the center mode.
- "TEST": Output a test tone.
- "CENTER": Adjust the center speaker output level.
- "CENTER TONE": Select the center tone.

For JVC Theater Surround:

- "CENTER MODE": Select the center mode.
- "TEST": Output a test tone.
- "CENTER": Adjust the center speaker output level.
- "REAR": Adjust the rear speaker output level.
- "DELAY": Adjust the delay time of the rear speaker sound.
- "CENTER TONE": Select the center tone.
- "EFFECT": Adjust the effect level.

For DAP modes:

- "REAR": Adjust the rear speaker output level. (This cannot be adjusted for "Headphones.")
- "EFFECT": Adjust the effect level.

8. **When you finish, press MENU EXIT.**
The menu disappears from the TV.

DAP MODE menu

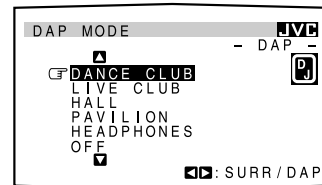

SURROUND MODE menu

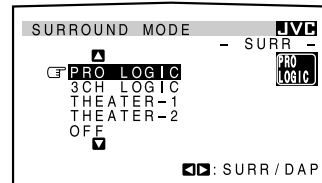

PRO LOGIC adjustment menu

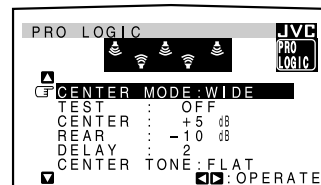

3CH LOGIC adjustment menu

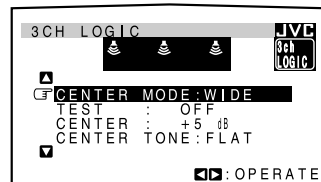

Theater Surround adjustment menu (eg. THEATER-1)

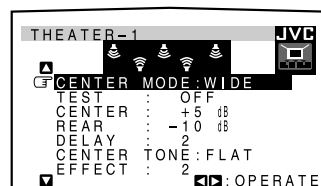

DAP mode adjustment menu (eg. DANCE CLUB)

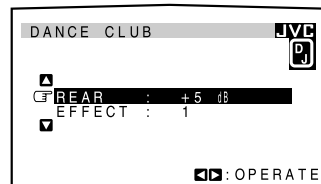

COMPU LINK Remote Control System

The COMPU LINK remote control system allows you to operate JVC audio components through the remote sensor on the receiver.

To use this remote control system, you need to connect JVC audio components through the COMPU LINK-3 (SYNCHRO) jacks (see below) in addition to the connections using cables with RCA pin plugs (see page 8).



Notes:

- If your audio component has two COMPU LINK-3 (SYNCHRO) jacks, you can use either one. If it has only one COMPU LINK-3 (SYNCHRO) jack, connect it so that it is the last item in the series of components. (For example, the turntable or CD player in the diagram above.)
- Refer also to the manuals supplied with your audio components.

This remote control system allows you to use four functions listed below.

■ Remote Control through the Remote Sensor on the Receiver

You can control the connected audio components through the remote sensor on the receiver using this remote control. For details, see pages 44 and 45.

Note:

Aim the remote control directly at the remote sensor on the receiver.

■ Automatic Source Selection

When you press the play (▶) button on a connected component or on its own remote control, the receiver automatically turns on and changes the source to the component. On the other hand, if you select a new source on the receiver or the remote control, the selected component begins playing immediately. In both cases, the previously selected source continues playing without sound for a few seconds.

■ Automatic Power On/Off (only possible with the COMPU LINK-3 connection)

Both the CD player and cassette deck turn on and off along with the receiver.

When you turn on the receiver, the CD player or cassette deck will turn on automatically, depending on which component has been previously selected.

When you turn off the receiver, both the CD player and cassette deck will turn off.

■ Synchronized Recording

Synchronized recording means the cassette deck starts recording as soon as a CD or a record begins playing.

To use synchronized recording, follow these steps:

- 1 Put a tape in the cassette deck, and a disc in the CD player (or a record on the turntable).
- 2 Press the record (●) button and the pause (||) button on the cassette deck at the same time. This puts the cassette deck into recording pause.

Note:

If you do not press the record (●) button and pause (||) button at the same time, the synchronized recording feature will not operate.

- 3 Press the play (▶) button on the CD player or on the turntable.

The source changes on the receiver, and as soon as play starts, the cassette deck starts recording. When the play ends, the cassette deck enters recording pause, and stops about 4 seconds later.

Notes:

- During synchronized recording, the selected source cannot be changed.
- If your CD player is playing in program mode, a 4-second blank is recorded between tracks so that the music scan feature of your cassette deck can be used on the recorded tape.
- If the power of any component is shut off during synchronized recording, the COMPU LINK remote control system may not operate properly. In this case, you must start again from the beginning.

AV COMPU LINK Remote Control System

The AV COMPU LINK remote control system allows you to operate JVC video components (TV, VCR, and DVD player) through the receiver.

CONNECTIONS:

To use this remote control system, you need to connect the video components you want to operate, following the procedures below.

CAUTION:

The AV COMPU LINK remote control system cannot control the video components connected to the VIDEO1, VIDEO2, and TAPE/VCR jacks on the receiver. Use only VCR1 jacks for the VCR and the DVD jacks for the DVD player.

1. Connect your VCR, DVD player, and TV as follows, using the AV COMPU LINK cable (only one cable is supplied with this receiver).

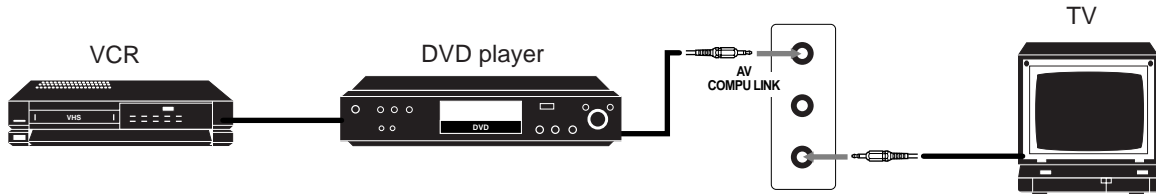

Note:

You can use one of the AV COMPU LINK jacks to connect the video components.

2. Connect the audio input/output jacks of the VCR, DVD player, and TV as follows using the cables with RCA pin plug. See page 9.
3. Connect the video input/output jack of the VCR, DVD player, and TV as follows.

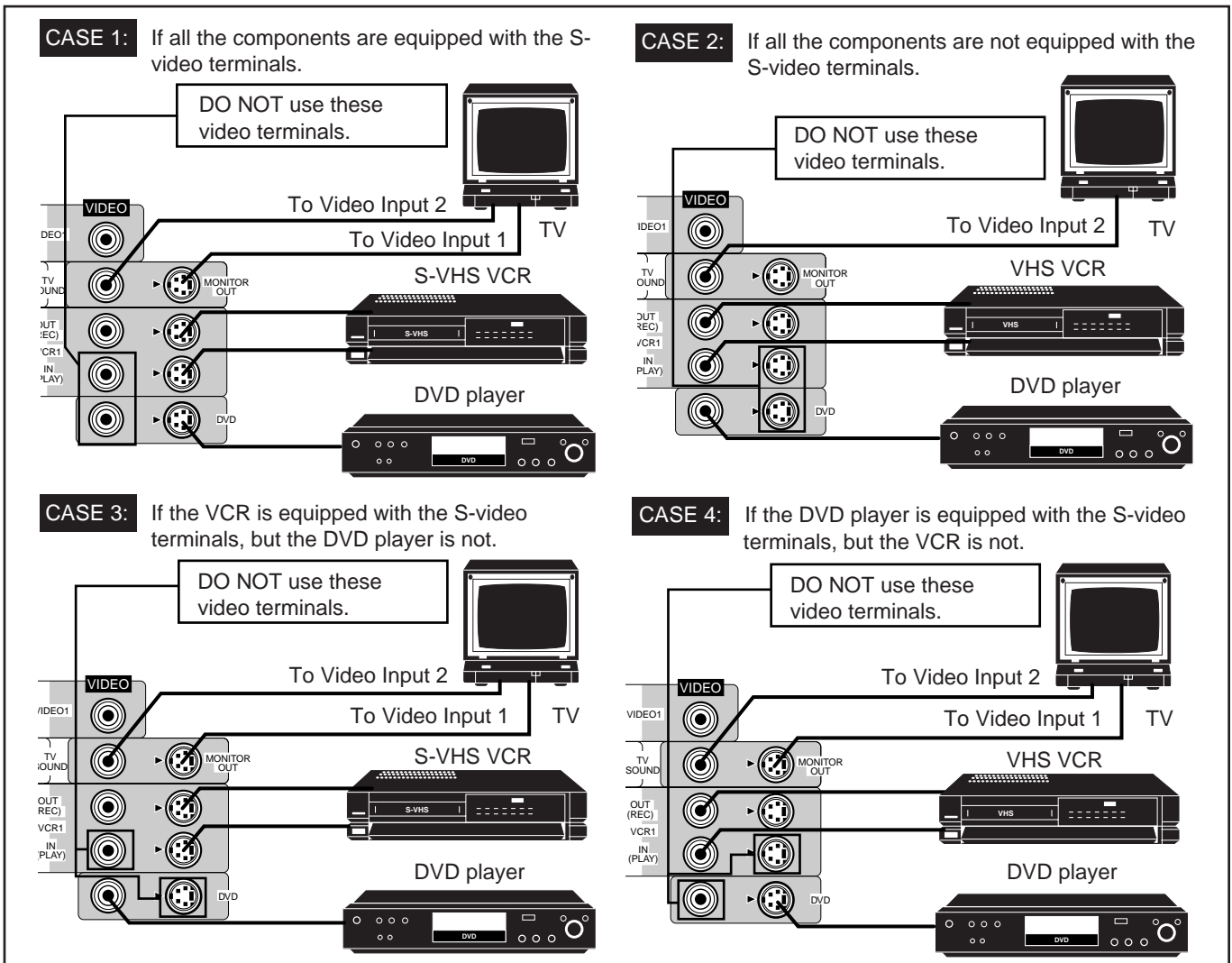

4. When turning on the TV for the first time after the AV COMPU LINK connection, turn the TV volume to the minimum using the TV volume control on the TV.

FUNCTIONS:

This remote control system allows you to use five functions listed below.

Note:

Refer also to the manuals supplied with your video components.

■ Remote Control of the TV through the Remote Sensor on the Receiver

You can control the TV through the remote sensor on the receiver using this remote control. For details, see page 47.

Note:

Aim the remote control directly at the remote sensor on the receiver when operating the TV. (However, to operate the VCR or DVD player, always aim the remote control directly at the remote sensor on the VCR or on the DVD player.)

■ One-Touch Video Play

Simply by inserting a video cassette without its safety tab into the VCR1 (the VCR connected to the VCR1 jacks), you can enjoy the video playback without setting other switches manually.

The receiver automatically turns on and changes the source to "VCR1."

The TV automatically turns on and changes the input mode to the position you can view the VCR playback. When you insert a video cassette with its safety tab, press the play (▶) button on the VCR1 or on the remote control. So, you can get the same result.

Note:

When you connect an S-VHS VCR or the DVD player as described on page 42, you cannot see the on-screen displays (such as Visual Confirmation and Menus) since the AV COMPULINK Remote Control System automatically changes the TV input mode to "Video input 1" when you operate the S-VHS VCR or the DVD player.

If you do not mind stopping watching the picture, you can then show the on-screen displays after changing the TV input mode to the position (Video input 2) the receiver is connected to.

■ One-Touch DVD Play

Simply by starting playback on the DVD player, you can enjoy the DVD playback without setting other switches manually.

The receiver automatically turns on and changes the source to "DVD" or "DVDMULTI" — DVD playback mode is automatically selected when a disc played in stereo or the audio output setting of the DVD player is mixed to two front channels, while DVD MULTI playback mode is automatically selected when a disc played back using the analog discrete output mode on the DVD player.

The TV automatically turns on and changes the input mode to the position so that you can view the playback picture.

■ Automatic Selection of TV's Input Mode

- When you select "TV SOUND" as the source to play on the receiver, the TV automatically changes the input mode to the TV tuner so that you can watch TV.
- When you select "VIDEO1," "VIDEO2," or "TAPE/VCR" as the source to play on the receiver, the TV automatically changes the input mode to the Video Input 2 so that you can watch the playback picture.
- When you select "DVD," "DVDMULTI," or "VCR1" as the source to play on the receiver, the TV automatically changes the input mode to the correct position (either Video Input 1 or 2) so that you can watch the playback picture.

Note:

When you select "TV SOUND" as the source on the receiver, you cannot see the on-screen displays (such as Visual Confirmation and the menu function) since the AV COMPULINK remote control system automatically changes the TV input mode to the TV tuner.

If you do not mind stopping listening to the TV sounds, you can then show the on-screen displays after changing the TV input mode to the position (Video input 2) the receiver is connected to.

■ Automatic Power On/Off

The TV, VCR1 (the VCR connected to the VCR1 jacks), and DVD player turn on and off along with the receiver.

When you turn on the receiver;

- If the previously selected source is "VCR1", the TV and VCR1 will turn on automatically.
- If the previously selected source is "VIDEO1," "VIDEO2," or "TV SOUND," only the TV will turn on automatically.
- If the previously selected source is "DVD" or "DVDMULTI," the TV and DVD player will turn on automatically.

When you turn off the receiver, the TV, VCR1 and DVD player will turn off.

Note:

If you turn off the receiver while recording on the VCR1, the VCR1 will not turn off, but continue recording.

Using the Remote Control for Operating JVC's Audio/Video Components

You can operate JVC's audio and video components with this receiver's remote control, since control signals for JVC components are preset in the remote control.

Notes:

- If you use the buttons on the front panel or the menu function to choose a source, the remote control will not operate that source. To operate a source with the remote control, the source must be selected using buttons on the remote control.
- Check to see if its remote control mode selector is set to the correct position. Normally, set it to the "TV / VCR / TUNER / CD / DVD / VCD" position. To activate the 10 keys for adjusting the sound, set it to the "SOUND CONTROL" position.
- Refer also to the manuals supplied with your components.

IMPORTANT

To operate JVC's audio components using this remote control:

- You need to connect JVC audio components through the COMPU LINK-3 (SYNCHRO) jacks (see page 41) in addition to the connections using cables with RCA pin plugs (see page 8).
- Aim the remote control directly at the remote sensor on the receiver.

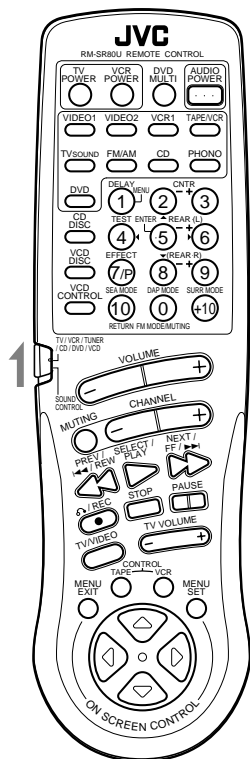

Tuner

After pressing FM/AM (with the remote control mode selector set to the "TV / VCR / TUNER / CD / DVD / VCD" position), you can perform the following operations:

- FM/AM:** Alternates between FM and AM.
- 1 — 10, +10:** Selects a preset channel number directly. For channel number 5, press 5. For channel number 15, press +10, then 5. For channel number 20, press +10, then 10.
- FM MODE/MUTING:** Changes the FM reception mode.

Sound control section (Amplifier)

With the remote control mode selector set to the "SOUND CONTROL" position, you can perform the following operations:

- SEA MODE:** Changes the SEA modes.
- DAP MODE:** Changes the DAP modes.
- SURR MODE:** Changes the surround modes.
- CNTR +/-:** Changes the center speaker output level for the DVD MULTI playback and surround modes.
- REAR•(L) +/-:** Changes the left/right rear speaker output level for DAP and surround modes. Changes the left rear speaker output level for the DVD MULTI playback mode.
- (REAR•R) +/-:** Changes the right rear speaker output level for the DVD MULTI playback mode.
- EFFECT:** Changes the effect level for DAP and surround modes.
- DELAY:** Changes the delay time for surround modes.
- TEST:** Checks the speaker output level for surround modes.

Note:

After adjusting sounds, set the remote control mode selector to the "TV / VCR / TUNER / CD / DVD / VCD" position to operate your target source by using 10 keys; otherwise, 10 keys cannot be used for operating your target source.

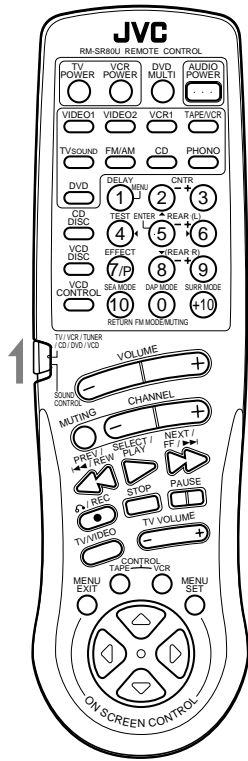

CD player

After pressing CD (with the remote control mode selector set to the "TV/VCR/TUNER/CD/DVD/VCD" position), you can perform the following operations on a CD player:

- PLAY:** Starts playing.
- ⏮:** Returns to the beginning of the current (or previous) track.
- ⏭:** Skips to the beginning of the next track.
- STOP:** Stops playing.
- PAUSE:** Pauses playing. To release it, press PLAY.
- 1 — 10, +10:** Selects a track number directly.
To select track number 5, press 5. For track number 15, press +10, then 5. For track number 20, press +10, then 10. For track number 30, press +10, +10, then 10.

CD player-changer

After pressing CD DISC (with the remote control mode selector set to the "TV/VCR/TUNER/CD/DVD/VCD" position), you can perform the following operations on a CD player-changer:

- PLAY:** Starts playing.
- ⏮:** Returns to the beginning of the current (or previous) track.
- ⏭:** Skips to the beginning of the next track.
- STOP:** Stops playing.
- PAUSE:** Pauses playing. To release it, press the PLAY button.
- 1 — 6, 7/P:** Select the number of a disc installed in a CD player-changer.

Turntable

After pressing PHONO (with the remote control mode selector set to the "TV/VCR/TUNER/CD/DVD/VCD" position), you can perform the following operations on a turntable:

- PLAY:** Starts playing.
- STOP:** Stops playing.

Cassette deck

After pressing TAPE/VCR or TAPE CONTROL (with the remote control mode selector set to the "TV/VCR/TUNER/CD/DVD/VCD" position), you can perform the following operations on a cassette deck:

- PLAY:** Starts playing.
- REW:** First rewinds the tape from right to left.
- FF:** First rewinds the tape from left to right.
- STOP:** Stops operations.
- PAUSE:** Pauses playing or recording temporarily. To release it, press the PLAY button.
- REC ●:** Press this button with the PLAY button to start recording.
Press this button with the PAUSE button to enter recording pause (standby).

Note:

You can use either the TAPE/VCR button or the TAPE CONTROL button to activate the buttons listed above. If you press TAPE/VCR, the playing source also changes to "TAPE/VCR." On the other hand, if you press TAPE CONTROL, the playing source does not change to "TAPE/VCR."

IMPORTANT

To operate JVC's video components using this remote control:

- Some JVC VCR can accept two types of the control signals — remote code “A” and “B.” Before using this remote control, make sure that the remote control code of the VCR connected to the VCR1 jacks is set to code “A.”
- When operating the video components, aim the remote control directly at **the remote sensor on the each component.**
- When the TV is connected with the AV COMPU LINK cable (see page 42) in addition to the connections using cables with RCA pin plugs (see pages 9 and 42), aim the remote control directly at **the remote sensor on the receiver to operate the TV.**

VCR

After pressing VCR1 or VCR CONTROL (with the remote control mode selector set to the “TV / VCR / TUNER / CD / DVD / VCD” position), you can perform the following operations on the VCR:

PLAY:	Starts playing.
REW:	Rewinds a tape.
FF:	Fast winds a tape.
STOP:	Stops operations.
PAUSE:	Pauses playing or recording temporarily. To release it, press the PLAY button.
REC ●:	Press this button with the PLAY button to start recording.
	Press this button with the PAUSE button to enter recording pause (standby).
CHANNEL +/-:	Changes the channels on the VCR.
1 — 9, 0:	Selects the channels on the VCR.

Notes:

- You can use either the VCR1 button or the VCR CONTROL button to activate the buttons listed above. If you press VCR1, the playing source also changes to “VCR1.” On the other hand, if you press VCR CONTROL, the playing source does not change to “VCR1.”
- You can also turn the VCR on and off by pressing VCR POWER on the remote control.

DVD player

After pressing DVD or DVD MULTI (with the remote control mode selector set to the “TV / VCR / TUNER / CD / DVD / VCD” position), you can perform the following operations on a DVD player:

PLAY:	Starts playing.
◀◀:	Returns to the beginning of the current (or previous) track.
▶▶:	Skips to the beginning of the next track.
STOP:	Stops playing.
PAUSE:	Stops playing temporarily. To release it, press the PLAY button.

After pressing DVD or DVD MULTI (with the remote control mode selector set to the “TV / VCR / TUNER / CD / DVD / VCD” position), these buttons can be used for the DVD menu operations.

**Note:**

For detailed menu operations, refer to the instructions supplied with the discs or the DVD player.

Video CD player

After pressing VCD DISC or VCD CONTROL (with the remote control mode selector set to the “TV/VCR/TUNER/CD/DVD/VCD” position) while playing back a Video CD player, you can perform the following operations:

PLAY:	Starts playing.
◀◀:	Returns to the beginning of the current (or previous) track.
▶▶:	Skips to the beginning of the next track.
STOP:	Stops playing.
PAUSE:	Stops playing temporarily. To release it, press the PLAY button.

After pressing VCD DISC (with the remote control mode selector set to the “TV/VCR/TUNER/CD/DVD/VCD” position) while playing back a Video CD player, you can also perform the following operation:

1 — 7/P: Select the number of a disc installed in a CD player-changer.

After pressing VCD CONTROL (with the remote control mode selector set to the “TV/VCR/TUNER/CD/DVD/VCD” position) while playing back a Video CD player, you can also perform the following operation:

1 — 10, +10: Selects a track number directly.
To select track number 5, press 5. For track number 15, press +10, then 5. For track number 20, press +10, then 10. For track number 30, press +10, +10, then 10.

After pressing VCD DISC or VCD CONTROL (with the remote control mode selector set to the “TV/VCR/TUNER/CD/DVD/VCD” position) while showing the Video CD player (with the PBC function) menu, you can perform the following menu operations.

PREV:	Views the previously shown portion of the menu.
SELECT:	Confirms the currently shown portion of the menu.
NEXT:	Views the unshown portion (continuation) of the menu.
⏪:	Goes back to the previous screen.

Note:

For detailed menu operations, refer to the instructions supplied with the discs or the Video CD player.

TV

After pressing TV SOUND (with the remote control mode selector set to the “TV/VCR/TUNER/CD/DVD/VCD” position), you can perform the following operations on a TV:

CHANNEL +/-:	Changes the channels.
TV VOLUME +/-:	Adjusts the volume.
1 — 9, 0, +10:	Selects the channels.
TV/VIDEO:	Sets the input mode (either TV or VIDEO).
RETURN:	Alternates between the previously selected channel and the current channel.

Note:

You can also turn the TV on and off by pressing TV POWER on the remote control.

This remote control supplied with the receiver can transmit control signals for other manufacturers' TVs. By changing the transmittable signals from preset ones to the other manufacturers', you can operate the other manufacturer's components using this remote control.

When operating the other manufacturers' components, refer also to the manuals supplied with them. To operate these components with the remote control, first you need to set the manufacturer's code for TV.

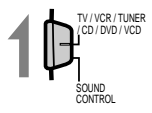

IMPORTANT
When using the Remote Control, check to see if its remote control mode selector is set to the **“TV / VCR / TUNER / CD / DVD / VCD”** position.

Note:

When you cannot use the remote control though you have preset a correct code to operate the other manufacturers' components, try again by following the procedure below.

1. Remove the batteries from the remote control.
2. Press **AUDIO POWER** once.
3. After one minute or more, insert the batteries to the remote control again.
4. Follow the procedures on this page and the following page again.

If you want to use the remote control to operate JVC's components, you do not need to follow this step.

To change the transmittable signals for operating another manufacturer's TV

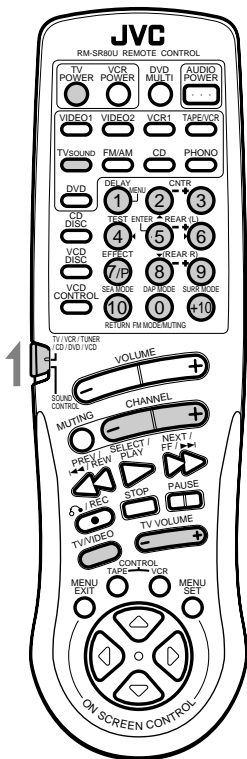

1. Set the remote control mode selector to the **“TV / VCR / TUNER / CD / DVD / VCD”** position.
2. Press and hold **TV POWER**.
3. Press **TV SOUND**.
4. Enter the manufacturer's code (three digits) using buttons **1 – 9**, and **0**.
See the lists on page 49 to find the code.
5. Release **TV POWER**.

The following buttons can be used for operating the TV (with the remote control mode selector set to the **“TV / VCR / TUNER / CD / DVD / VCD”** position):

TV POWER: Turns on and off TV.

After pressing **TV SOUND** you can perform the following operations on the TV:

CHANNEL +/-: Changes the channels.

TV VOLUME +/-: Adjusts the volume.

1 — 10, 0, +10: Selects the TV channels.

+10 button will function as the **ENTER** button if your TV requires pressing **ENTER** after selecting a channel number.

TV/VIDEO: Sets the input mode (either TV or VIDEO).

Note:

Refer also to the manual supplied with your TV.

6. Try to operate your TV by pressing **TV POWER**.
When your TV turns on or off, you have entered the correct code.
7. If there are more than one code listed for your brand of TV, try each one until the correct one is entered.

Manufacturers' codes for TV

Aiwa	10
Beijing	05
Changhong	05, 06, 16, 25
Daewoo	11
Ferguson	15
Finlux	20
Funai	09
Grundig	17
Hitachi	07
ITT	18
Jinxiang	23
JVC	01
Konka	26
LG (Goldstar)	13
Mitsubishi	06
Mivar	19
NEC	22
Noblex	27
Nokia	21
Panasonic	02
Peijin	27
Peony	23, 24, 25
Philips	16
Samsung	12
Sanyo	08
Sharp	04
Sony	03
TCL	16, 28
Thomson	14
Toshiba	05

Manufacturers' codes listed on this page are subject to change without notice. If they are changed, this remote control cannot operate the equipment.

Use this chart to help you solve daily operational problems. If there is any problem you cannot solve, contact your JVC service center.

PROBLEM	POSSIBLE CAUSE	SOLUTION
The display does not light up.	The power cord is not plugged in.	Plug the power cord into an AC outlet.
No sound from speakers.	Speaker signal cables are not connected.	Check speaker wiring and reconnect if necessary.
	The SPEAKERS 1 and 2 buttons are not set correctly.	Press SPEAKERS 1 and 2 correctly. (See page 13.)
	An incorrect source is selected.	Select the correct source.
	Mute is activated.	Press MUTING to cancel the mute.
Sound from one speaker only.	Speaker signal cables are not connected properly.	Check speaker wiring and reconnect if necessary.
	The balance is set to one extreme.	Adjust the balance properly.
Continuous hiss or buzzing during FM reception.	Incoming signal is too weak.	Connect an outside FM antenna or contact your dealer.
	The station is too far away.	Select a new station.
	An incorrect antenna is used.	Check with your dealer to be sure you have a correct antenna.
	Antennas are not connected properly.	Check connections.
Occasional cracking noise during FM reception.	Ignition noise from automobiles.	Move the antenna farther from automobile traffic.
The analog discrete output sound of the DVD player cannot be reproduced correctly.	An incorrect source is selected.	Select "DVDMULTI" as the source on the receiver.
	The sound setting of the DVD player is incorrect.	Check the sound setting of the DVD player.
No colors on the on-screen display.	The color system of the connected TV is not PAL.	Connect an PAL TV.
Howling during record playing.	Your turntable is too close to speakers.	Move speakers away from the turntable.
Remote control does not work.	The remote control mode selector is not set correctly.	Set the selector correctly either to the "TV / VCR / TUNER / CD / DVD / VCD" position or to "SOUND CONTROL" position.
	There is an obstruction in front of the remote control sensor on the receiver.	Remove the obstruction.
	Batteries are weak.	Replace batteries.

Specifications

Amplifier

Output Power	At Stereo operation	120 watts per channel, min. RMS, both channels driven into 8 ohms at 1 kHz with no more than 0.9 % total harmonic distortion. (IEC268-3/DIN)
	At Surround operation	
	Front Channels	120 watts per channel, min. RMS, driven into 8 ohms at 1 kHz with no more than 5 % total harmonic distortion.
	Center channel	120 watts, min. RMS, driven into 8 ohms at 1 kHz, with no more than 5 % total harmonic distortion.
	Rear channels	60 watts per channel, min. RMS, driven into 8 ohms at 1 kHz, with no more than 5 % total harmonic distortion.
Total Harmonic Distortion (8 ohms, 1 kHz)		0.02 %* at 90 watts output (* Measured by JVC Audio Analysis System)
Audio Input Sensitivity/ Impedance (1 kHz)	PHONO (MM) CD, TAPE/VCR, TV SOUND, VCR1, VIDEO1, VIDEO2, DVD (FRONT/ CENTER/REAR/SUBWOOFER)	2.5 mV/47 k ohms 230 mV/47 k ohms
Audio Output Level	TAPE/VCR, VCR1	230 mV
Signal-to-Noise Ratio (\approx 66 IHF/DIN)	PHONO CD, TAPE/VCR, TV SOUND, VCR1, VIDEO1, VIDEO2, DVD	70 dB/66 dB (at REC OUT) 87 dB/67 dB
Frequency Response (8 ohms)	PHONO CD, TAPE/VCR, TV SOUND, VCR1, VIDEO1, VIDEO2, DVD	20 Hz to 20 kHz (\pm 0.5 dB) 20 Hz to 20 kHz (\pm 1 dB)
RIAA Phono Equalization		\pm 0.5 dB (20 Hz to 20 kHz)
Loudness Control (Volume Control at -40 dB)		+6 \pm 1 dB at 100 Hz +4 \pm 1 dB at 10 kHz
S.E.A.	Center Frequencies Control Range	100 Hz, 1 kHz, 10 kHz \pm 10 dB \pm 2 dB

Video

Video Input Sensitivity/Impedance	TAPE/VCR, VCR1, DVD, VIDEO1, VIDEO2	Composite video:	1 Vp-p/75 ohms
	TAPE/VCR, VCR1, DVD	S-video (Y:luminance):	1 Vp-p/75 ohms
		S-video (C:chrominance, burst):	0.286 Vp-p/75 ohms
Video Output Level	TAPE/VCR, VCR1, MONITOR OUT	Composite video:	1 Vp-p/75 ohms
		S-video (Y:luminance):	1 Vp-p/75 ohms
		S-video (C:chrominance, burst):	0.286 Vp-p/75 ohms
Synchronization		Negative	
Signal-to-Noise Ratio		45 dB	
On-Screen Color System		PAL	

FM tuner (IHF)

Tuning Range		87.5 MHz to 108.0 MHz
Usable Sensitivity	Monaural	12.7 dBf (1.2 μ V/75 ohms)
50 dB Quieting Sensitivity	Monaural	16.3 dBf (1.8 μ V/75 ohms)
	Stereo	38.3 dBf (22.5 μ V/75 ohms)
Signal-to-Noise Ratio (IHF-A weighted)	Monaural	80 dB at 85 dBf
	Stereo	73 dB at 85 dBf
Total Harmonic Distortion	Monaural	0.15 % at 1 kHz
	Stereo	0.2 % at 1 kHz
Stereo Separation at REC OUT		40 dB at 1 kHz
Capture Ratio		1.5 dB at 85 dBf
Alternate Channel Selectivity		60 dB: (\pm 400 kHz)
Frequency Response		30 Hz to 15 kHz: (+0.5 dB, -3 dB)

AM tuner

Tuning Range		531 kHz to 1,602 kHz
Usable Sensitivity	Loop antenna	300 μ V/m
	External antenna	30 μ V
Signal-to-Noise Ratio		50 dB (100 mV/m)

General

Power Requirements		AC 220V [~] , 50 Hz
Power Consumption		370 watts
		2 watts (in standby mode)
Dimensions (W \times H \times D)		435 \times 156.5 \times 412 mm
Mass		12.6 kg

Designs & specifications are subject to change without notice.

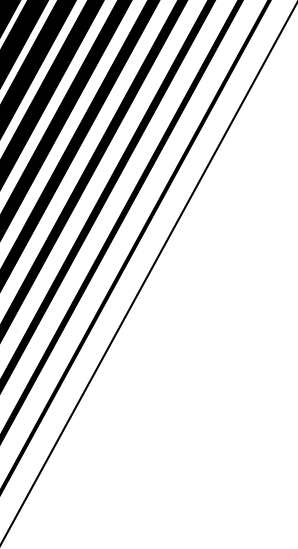

Free Manuals Download Website

<http://myh66.com>

<http://usermanuals.us>

<http://www.somanuals.com>

<http://www.4manuals.cc>

<http://www.manual-lib.com>

<http://www.404manual.com>

<http://www.luxmanual.com>

<http://aubethermostatmanual.com>

Golf course search by state

<http://golfingnear.com>

Email search by domain

<http://emailbydomain.com>

Auto manuals search

<http://auto.somanuals.com>

TV manuals search

<http://tv.somanuals.com>