

JVC®

The Perfect Experience

RX-D702 TECHNICAL GUIDE

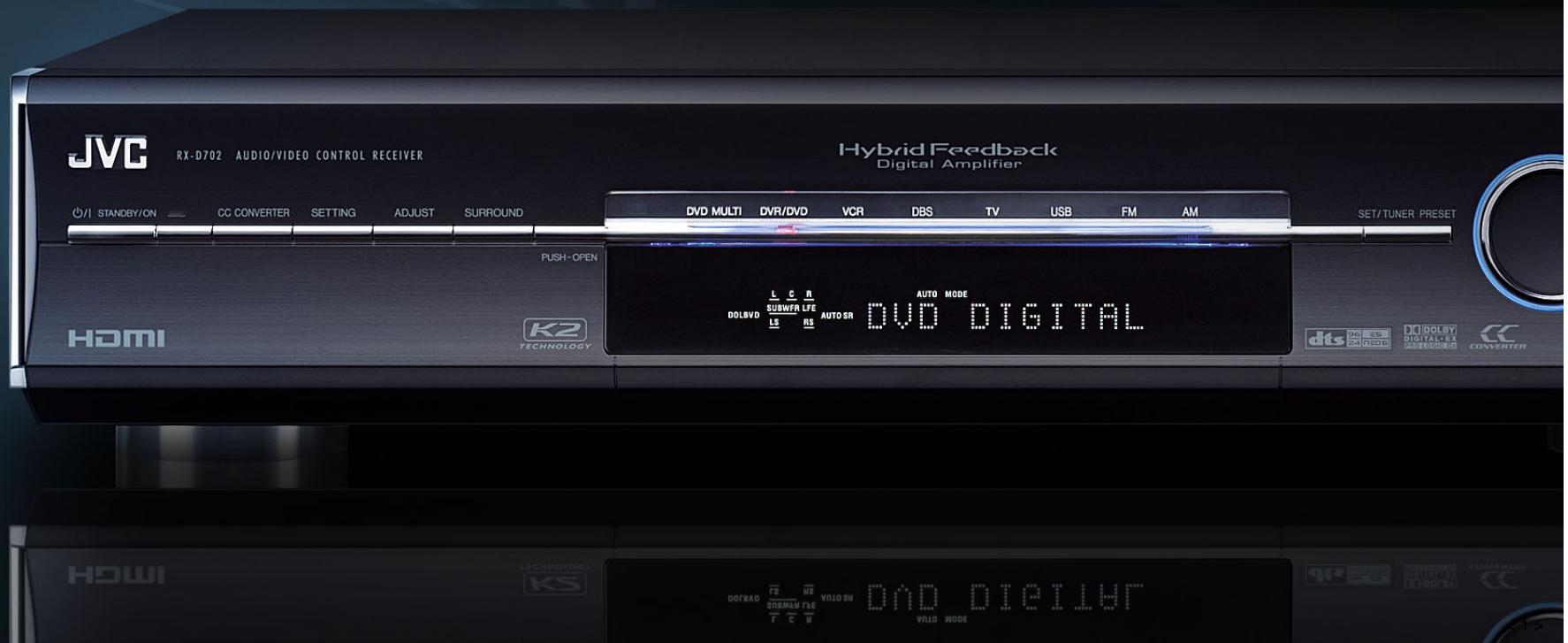

High-Power 7.1-Channel A/V Control Receivers -- A Host of Digital Technologies Applied for Superior Sound, Pictures, and Style.

JVC now offers the latest-generation of AV control receivers -- RX-D702, RX-D402, and RX-D401 -- which feature a sleek profile to complement today's and future home cinema systems.

But what gears the units for the future home cinema is not only the stylish design. Despite the slim dimensions, the units are ready to deliver powerful, high-quality sound from various sources -- including PC music files -- and provide superior picture quality, too. What's more, their expanded connectivity lets you easily connect the units with your PC, and even permits HDMI connections -- the latest interface for transmitting audio/video signals.

Enabling these and many other feats are a host of advanced digital technologies newly incorporated into the units.

In this technical guide, you will see the details of those technologies and find how the advanced A/V receivers will upgrade your digital home theater systems.



Design Concepts

1 High-Quality Pictures -- Advanced Technologies that Even Permit HDMI Compatibility

2 PC Link -- USB Connection for Receiving Uncompressed PCM Data from PC

3 CC Converter -- A JVC-Original Technology for Superior Sound

4 Aureus™ -- High-Performance DSP for Superior Sound Quality

5 Hybrid Feedback Digital Amplifier Ver.III -- An Upgraded Version of JVC-Trademark Digital Amp for Unmatched Sound Quality

1 High-Quality Pictures



The JVC A/V receivers deliver not only superior sound, but also superb pictures with a host of advanced technologies. The units feature HDMI terminals and use of DCDi by FAROUDJA.



HDMI

HDMI -- The Next-Generation Digital Interface 05

HDMI -- Easy Connections for All-Digital Transmission 06

DCDi by FAROUDJA

Connection Example -- RX-D702 07

Connection Example -- RX-D402/RX-D401 08

What is DCDi by FAROUDJA? 09

Effect Examples (1) 10

Effect Examples (2) 11



HDMI -- The Next-Generation Digital Interface

RX-D702

RX-D402

*Also applies to RX-D401

HDMI (High-Definition Multimedia Interface) -- An Industry-Supported, Digital Audio/Video Interface Developed for Next-Generation Home AV Devices.

Its remarkable benefits include:

- 1. All digital provides the highest quality available --**
HDMI is the only interface in the industry that can handle both uncompressed high-definition video and uncompressed multi-channel audio. Supported HD video formats include 720p, 1080i and even upcoming 1080p.
- 2. A single-cable connection for transmission of high-quality audio and video signals**
- 3. HDCP (High-bandwidth Digital Content Protection) is supported**



		Analog	Digital	
		Component Video	DVI	HDMI
Cable	Video	3	1	1
	Audio	2	2	
Remote Control		-	-	Yes
PC Compatibility		-	Yes	Yes
Content Protection		-	Yes	Yes
Signal Format		YPbPr	RGB	YPbPr/RGB
Application		Consumer AV	PC	Consumer AV

HDMI Founders
 Hitachi
 Matsushita (MEI)
 Philips
 Silicon Image
 SONY
 Thomson Multimedia
 Toshiba



HDMI -- Easy Connections for All-Digital Transmission

RX-D702

RX-D402

*Also applies to RX-D401

Single-Cable Connections

10 Audio + 9 Video Cables

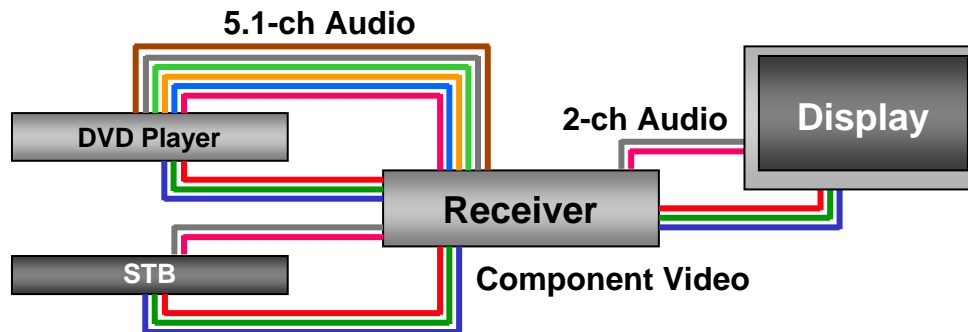

3 HDMI Cables



All-Digital Transmission of High-Quality Video & Audio

Even System Control is available

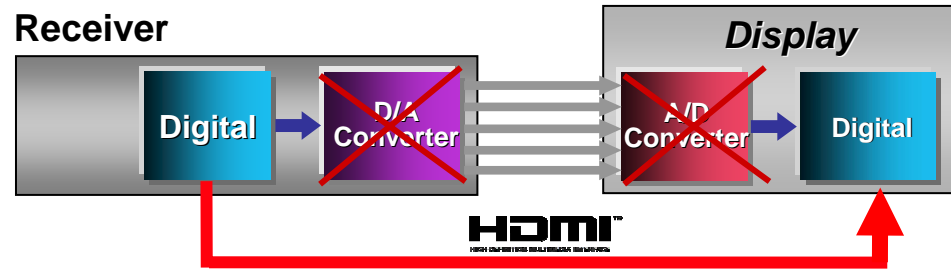



Connection Example -- RX-D702

RX-D702

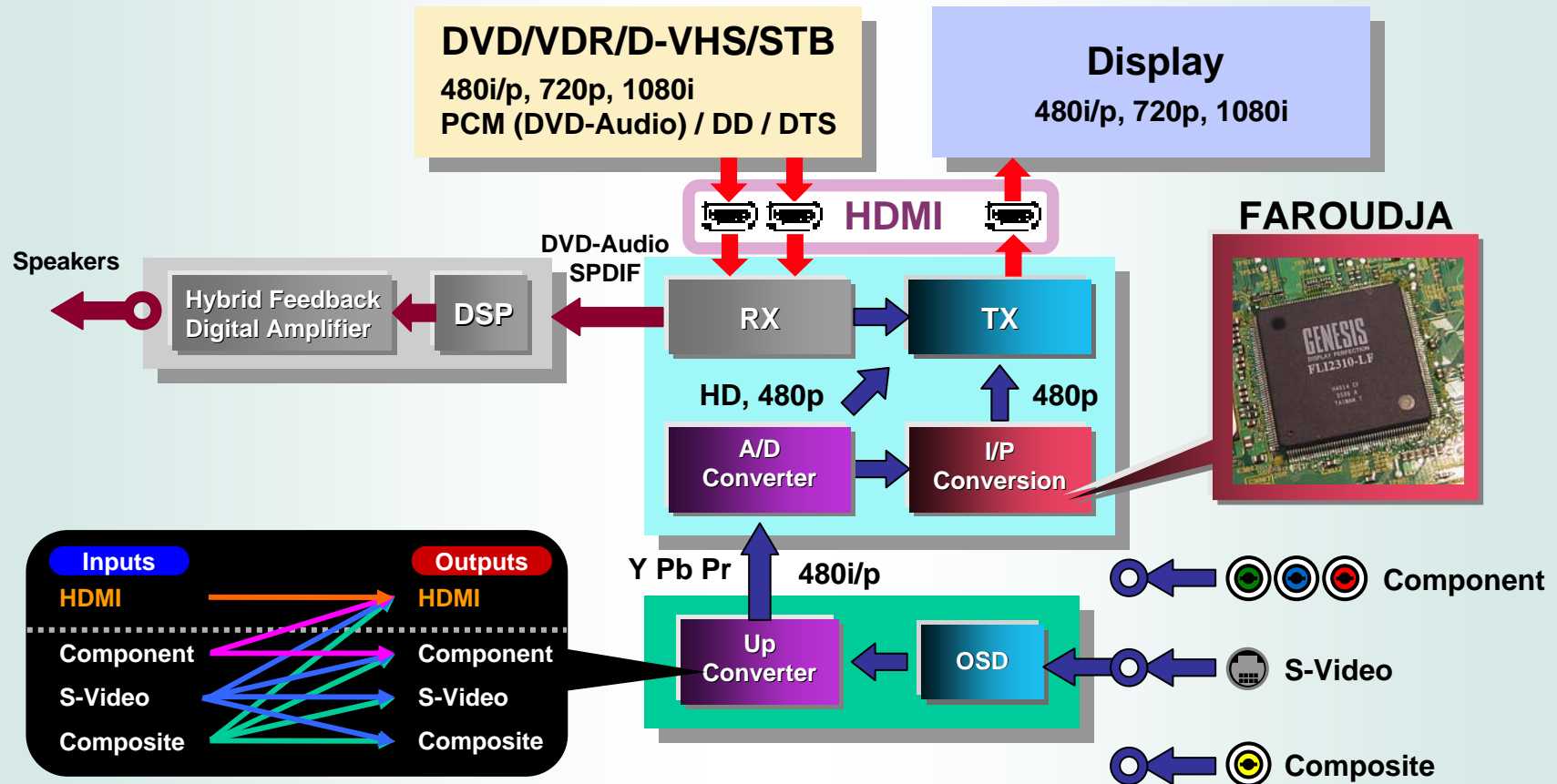



Connection Example -- RX-D402/D401

RX-D402

*Also applies to RX-D401

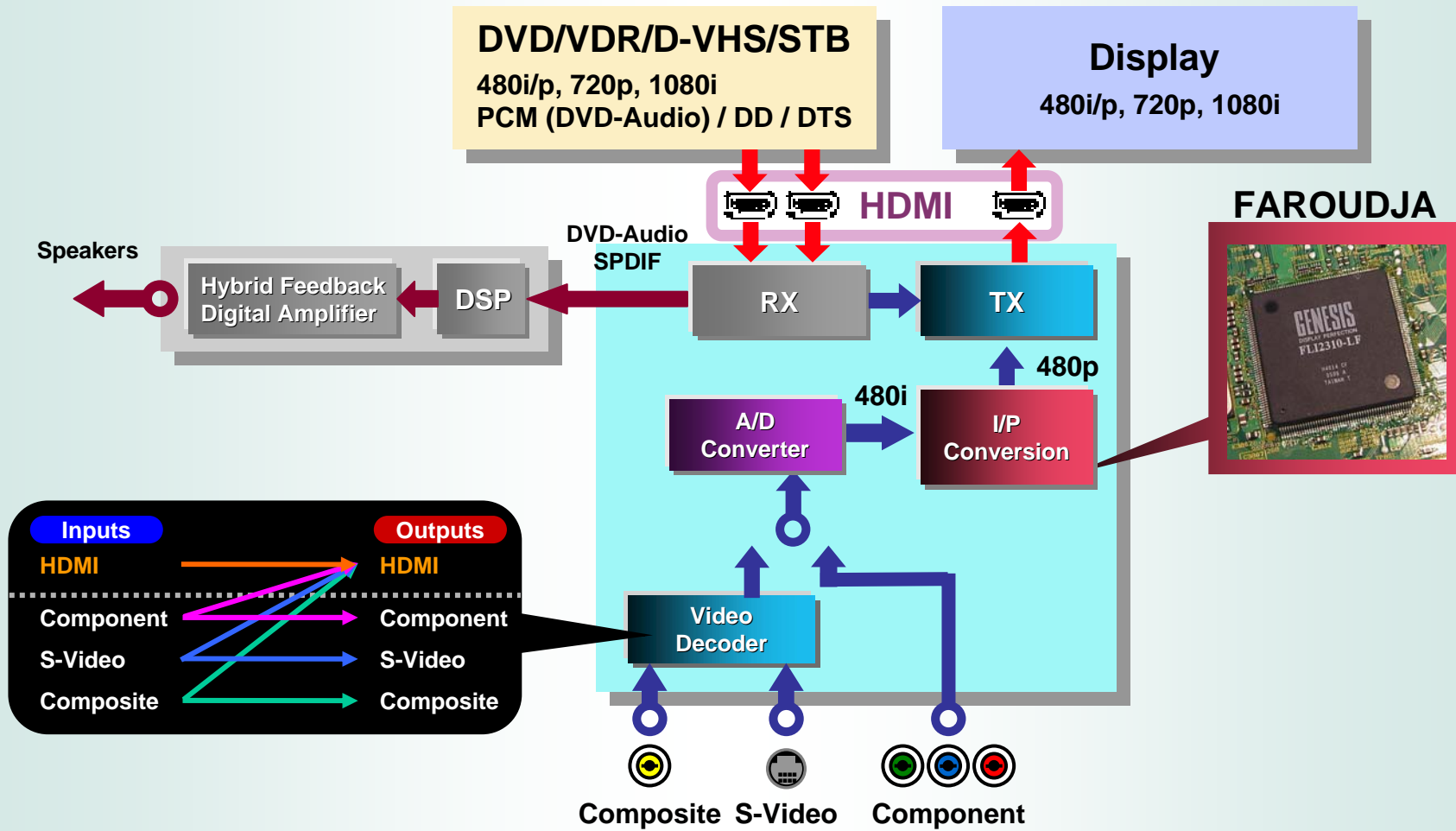



What is DCDi by FAROUDJA?

The new A/V receivers can convert video signal format to HDMI for display on a compatible monitor, whether the signals are from Composite, S-Video, or Component input. In this process, the unit converts interlaced pictures to progressive ones -- a process known as "IP conversion" -- using "DCDi by FAROUDJA", a renowned, high-performance device. It features a host of advanced technologies for noise reduction and reproduction of high-definition pictures, including:

RX-D702

RX-D402

*Also applies to RX-D401



3D Deinterlacer

Film Mode: Recreates the original film frames by accurately blending the fields back together in progressive scanning -- for images free of motion artifacts and with full vertical resolution.

Video Mode: Delivers pictures from video sources by eliminating jagged edges on diagonal lines.



3D Noise Reduction

Filters out the noise temporally, without smearing or ghosting of moving objects in the image.

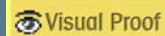

3D Cross Color Suppression

Prevents leakage of color information to chroma channels.



Fleshtone Adaptive Noise Reduction

Controls noise reduction coefficient to deliver optimum human flesh color.

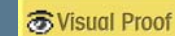



Effect Examples (1)

RX-D702

RX-D402

*Also applies to RX-D401

3D Deinterlacer

A unique algorithm that identifies all the moving edges in a scene and adjusts the angle of interpolation at each pixel so that the interpolation always follows the edge instead of crossing it, eliminating staircasing or jagged edge artifacts.



Jagged Edges on Diagonal Lines

Smooth diagonal lines are also delivered by the 3D Deinterlacer.



Smooth Diagonal Edges



Cross-Color Suppression

While composite signals are decoded, high-frequency luma information leaks into the chroma channel, generating noise that looks like flashing colors or rainbow patterns.

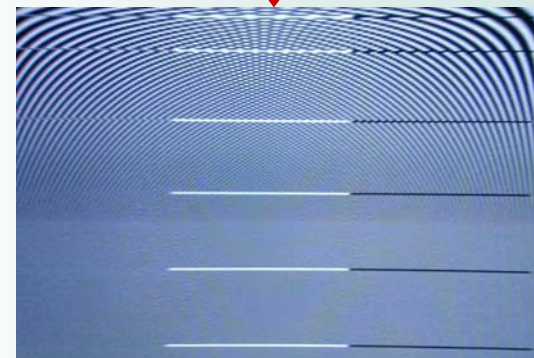
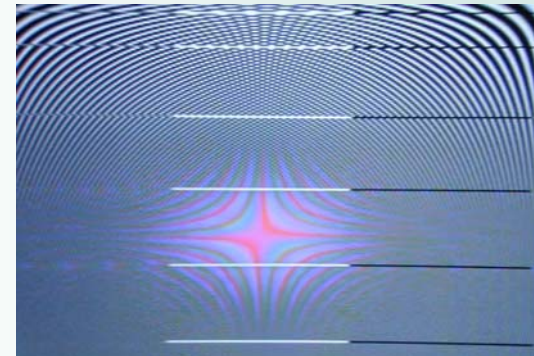

The Cross-Color Suppression effectively eliminates the noise with high-performance chroma processing.



Effect Examples (2)

RX-D702

RX-D402

*Also applies to RX-D401

Fleshtone Adaptive Noise Reduction

Noise reduction applied on overall picture may cause an adverse effect -- unnatural flesh color. The Fleshtone Adaptive NR detects flesh color contained in a picture and controls noise reduction coefficient to deliver optimum human flesh color.

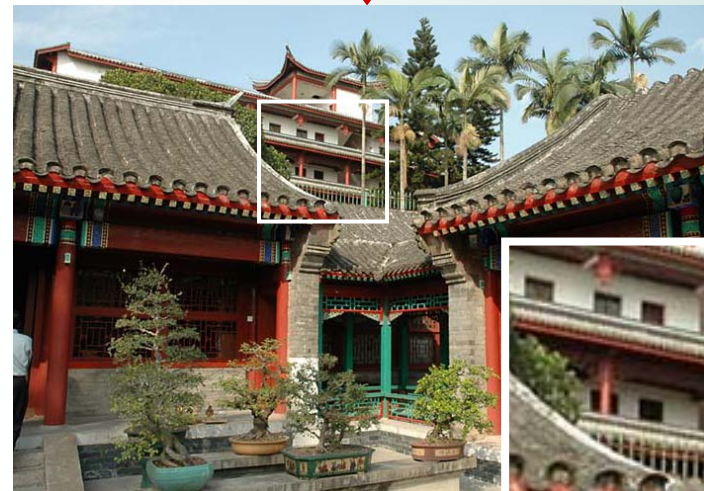
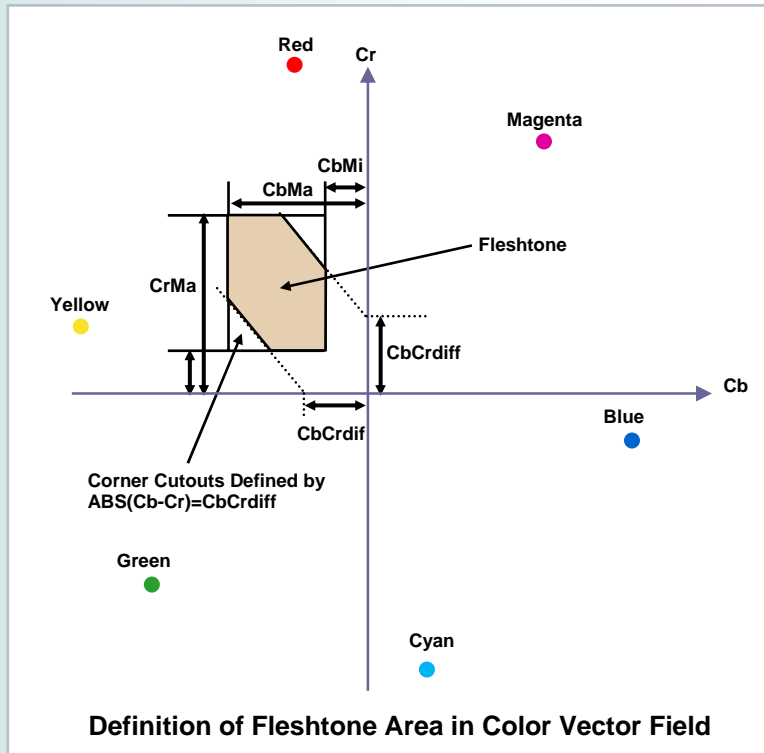



The RX-D702 permits transmission of stereo audio signals from your PC (MP3, WMA, Linear PCM, etc.) for listening via your audio system. The unit even permits wireless USB transmission, which ensures superior, near-CD sound quality as well as enhanced convenience.

Wireless USB Connection

Superior Sound Quality Matching CD/DVD	13
User ID Learning Function & Auto Scan	14
Comparison of Signal Formats	15

USB Connection

Transmission of Stereo Audio Signals from PC	16
--	----



Superior Sound Quality Matching CD/DVD

RX-D702



- (1) The **2Mbps** high transmission rate using the **2.4GHz** band permits transmission of uncompressed signals for lossless reproduction.
- (2) Input signals are **free of D/A or A/D conversion** until just before output, which prevents conversion loss.
- (3) Use of DSSS (Direct Sequence Spread Spectrum) modulation technology enables transmission of **uncompressed signals** with superior resistance against noise, which retains superb sound quality.
- (4) Corresponds to 16-bit, **32kHz/44.1kHz/48kHz** sampling rates.
- (5) Almost real-time data transmission -- delay time is only **2 msec** or less.



User ID Learning Function & Auto Scan

RX-D702

User ID Learning Function

To ensure security, the wireless USB transmitter and the RX-D702 share a specific “user ID”. This means devices without the same ID cannot receive signals from the transmitter. And when you replace the transmitter, “User ID Learning Function” would be convenient. This function lets you easily set up a new user ID, so that the unit can receive signals from the new transmitter.

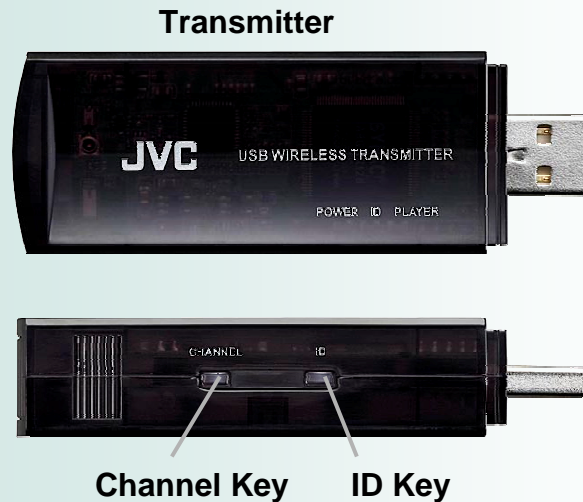

Auto Scan

The Wireless USB additionally features “Auto Scan”, which stops interruption from other signals in the same room. When the system is turned on, this function automatically detects electric waves from other devices -- wireless LAN, for example -- and selects a band that won't be interrupted by the other signals.

When the signal transmission is interfered by other waves while using the unit, simply press and hold the “Channel Key” (on the transmitter) for a few seconds. The transmitter automatically switches the band to a one that won't be interfered by the waves.

Channel No.	Center Frequency	Channel No.	Center Frequency
1	2,412 MHz	8	2,447 MHz
2	2,417 MHz	9	2,452 MHz
3	2,422 MHz	10	2,457 MHz
4	2,427 MHz	11	2,462 MHz
5	2,432 MHz	12	2,467 MHz
6	2,437 MHz	13	2,472 MHz
7	2,442 MHz		





Comparison of Signal Formats

RX-D702

	Bluetooth	JVC	Wifi/802.11b
Format Data Rate	Compression (due to low data rate) 1Mbps	No Compression 2Mbps	Compression No Compression 11Mbps
Delay Time	Approx. 400msec	Under 2msec	Approx. 600msec

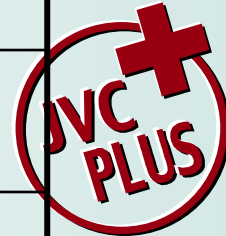

Our Outstanding Points (Compared with Other Wireless Products)

		Model A	Model B
Feature	Wired	Ethernet	Ethernet
	Wireless	Wireless LAN (Optional) Exclusive Network Only	Wireless LAN (Optional) PCMCIA Card Slot: for still pictures from digital cameras Control with OSD: = Movie, Music, Pictures

JVC Advantages

- No optional device required.
- Receives signals from any PC (including Mac).
- CC Converter improves the sound quality of compressed music files from PC.





Transmission of Stereo Audio Signals from PC

RX-D702

RX-D402

*Also applies to RX-D401

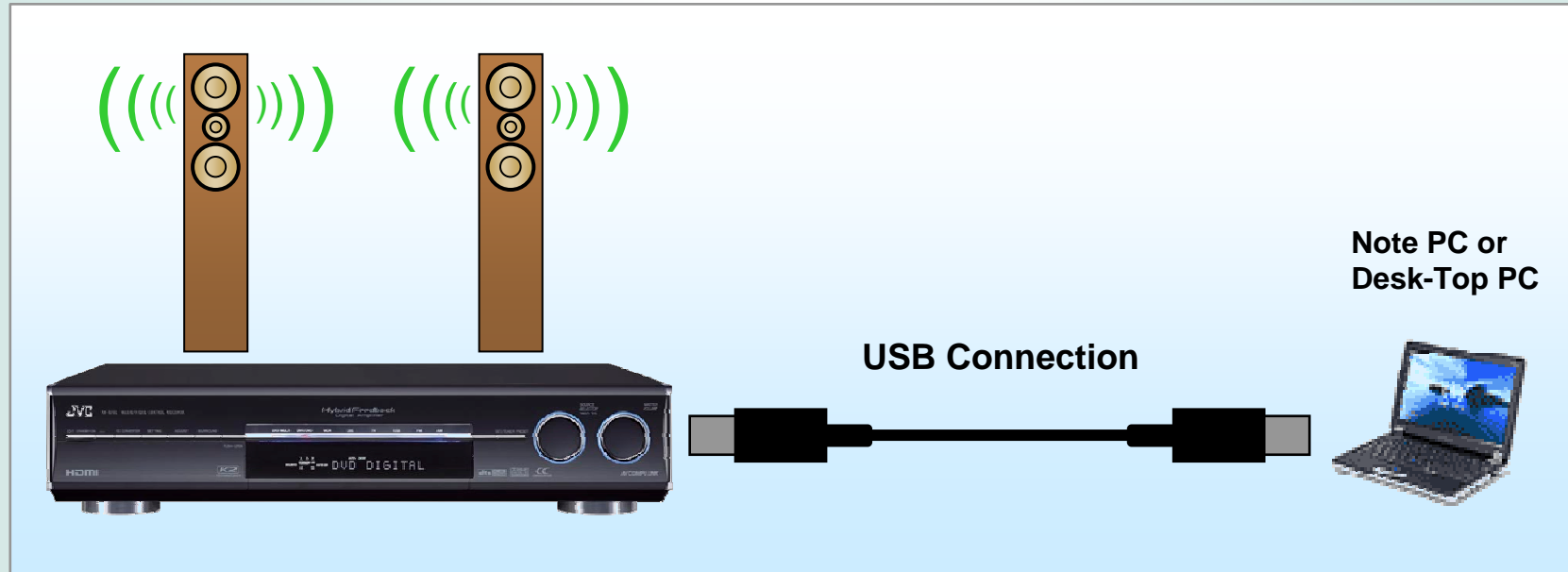

- (1) Corresponds to **16-bit, 32kHz/44.1kHz/48kHz sampling rates** for superior sound.
- (2) Permits playback of any music files that can be played on the connected PC, regardless of the software (Windows **Media Player**, **iTunes**, etc).
- (3) **All-digital** transmission --> **No D/A or A/D conversion.**

3 CC Converter -- A JVC-Original Technology for Superior Sound



K2 Processing is the result of a close collaboration among JVC studio engineers, producers and hardware engineers, embodying the elaborate algorithms for a sound quality that is close to the master by professional standards. The CC Converter is one of its applications to improve the sound quality of not only pure audio sources but also compressed files, such as dts, Dolby Digital, and MP3. The CC Converter lets you experience a sound that is truer to the original master than ever. With the RX-D702, front L/R channels are processed by the CC Converter.

CC Converter

Background	18
Problems with Digital Conversion	19
Problem: An analog signal of a very faint strength cannot be accurately recreated by A/D and D/A conversion. (1)	20
Problem: A high-frequency analog signal cannot be accurately recreated by A/D and D/A conversion. (2)	21
CC Converter	22
Bit Expansion Section	23
Frequency Conversion Section/Range Expansion Section	24
CC Converter: How its workings differ from other high-bit/upsampling systems	25
Comparison of -90dB, 1kHz Sine Waves: Bit Expansion On vs. Off	26
Comparison of Frequency Spectra: Range Expansion On vs. Off	26

P.E.M. D.D. Converter

D.D. Converter	27
Noise Shaping Response/Noise Spectrum	28
192kHz/24-bit and 96kHz/24-bit A/D Converters -- RX-D702	29
192kHz/24-bit and 96kHz/24-bit A/D Converters -- RX-D402/D401	30



Digital audio started with Compact Disc and has since given birth to such super high-fidelity formats as DVD Audio and SACD. There's another trend in digital audio: compressed data formats. Music distribution over the Internet, silicon audio using compact IC cards, and digital broadcast by satellite -- all these formats take advantage of audio compression technology. This means there are two diverging trends in digital audio -- higher fidelity and higher compression.



JVC is not only a hardware maker but also a software producer as well, so there has been a close collaboration between the hardware engineers and studio engineers for all aspects of digital sound production. "K2 Processing Technology" is one of the many improvements developed by this collaboration to achieve higher sound quality. It was implemented as the "Extended K2 Processing," a critically acclaimed application to pure audio. The CC Converter is an adaptation of this technology for compressed music. Therefore, it improves the sound quality of both hi-fi sources such as CD and DVD (Linear Mode) and compressed music formats including MP3 and WMA (Compression Mode), benefiting a wide range of digital audio contents.

Sound Formats and Media: Quality vs. Compression

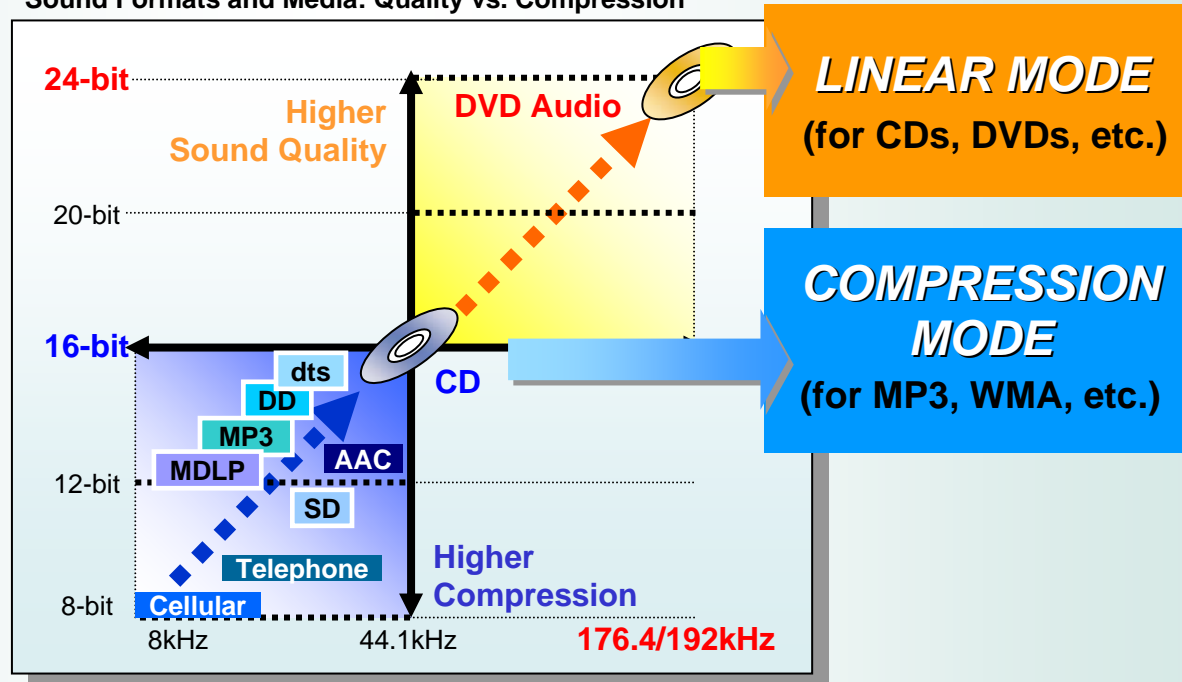



In digital audio, music is processed in digital form. The music played by musicians in a recording studio or a concert hall is picked up by a microphone and recorded in digital form, to be released for sale as packaged media, including CD. The consumers buy the CD to play on a CD player: the recorded music is converted from digital to analog for playback through an amplifier and speakers. The process of playing digital music involves analog/digital conversion and digital/analog conversion as shown below.

Process of Playing Digital Music

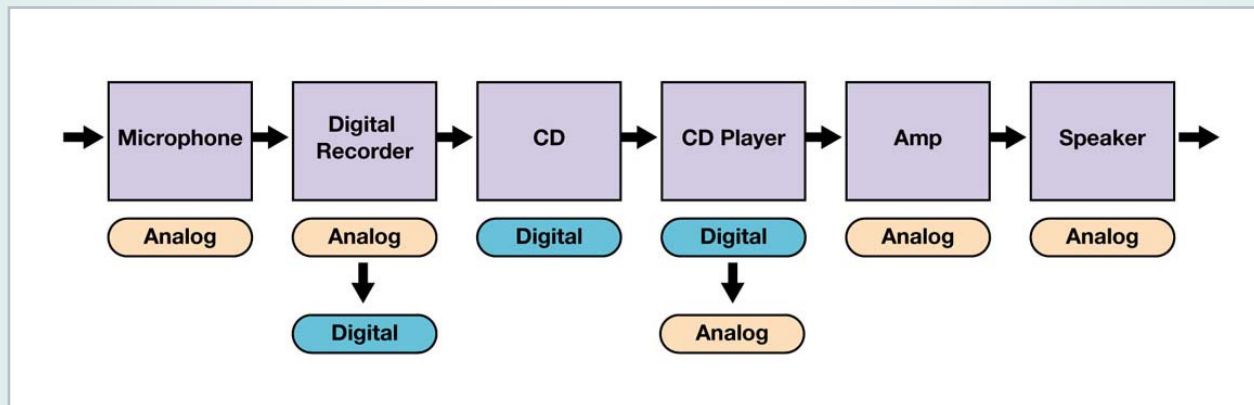

The sound quality of a signal depends on the following two factors when the signal is converted from analog to digital.

- Quantization wordlength (bits), which determines resolution or the expression of music in the amplitude domain.
- Sampling frequency, which determines the frequency response or the expression of music in the frequency domain.



Problem: An analog signal of a very faint strength cannot be accurately recreated by A/D and D/A conversion. (1)

RX-D702

When its level is high, a 1kHz signal can produce a smooth waveform after the A/D and D/A conversion. When the level is low, however, a stepped waveform results due to the limitation in the resolution of a digital signal. This phenomenon occurs because digital quantization distortion increases as the levels are reduced.

A/D and D/A Conversion in Amplitude Domain

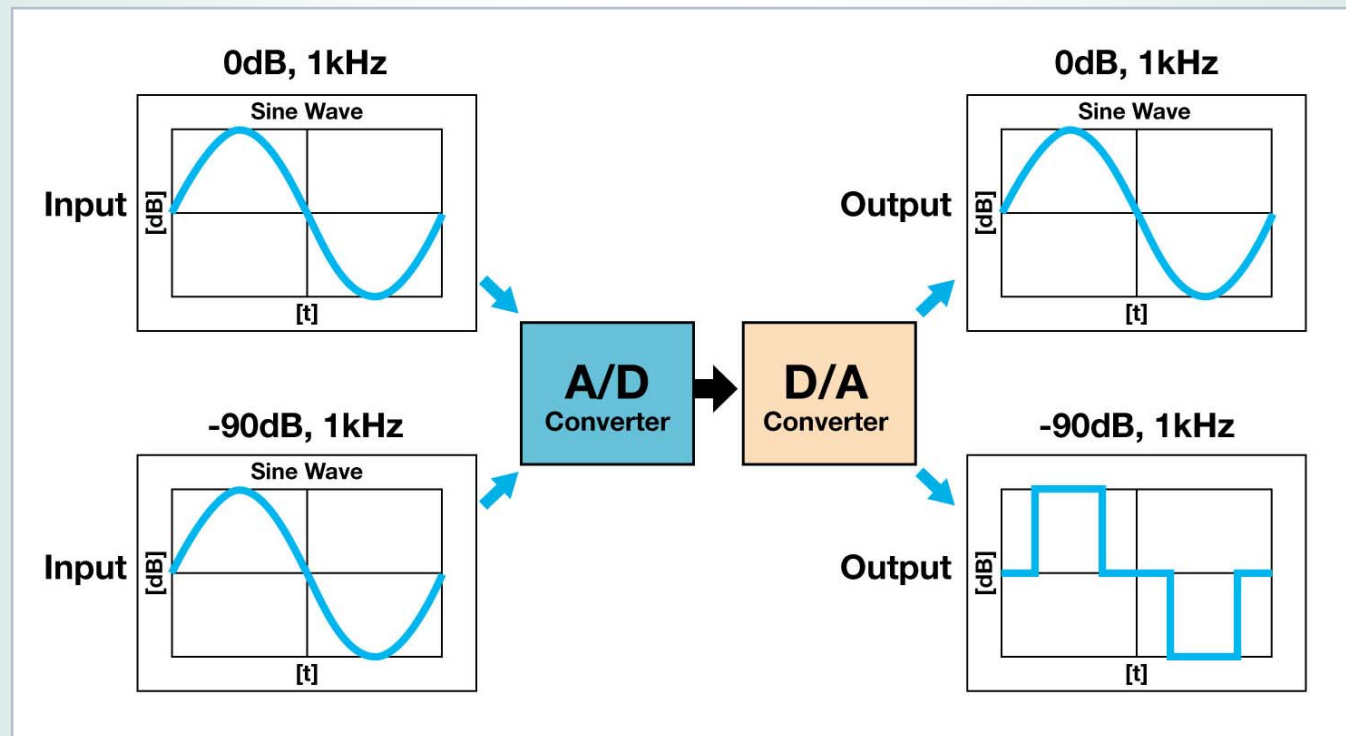

Problem: A high-frequency analog signal cannot be accurately recreated by A/D and D/A conversion. (2)
RX-D702

The “sampling theorem” says that, if the sampling frequency is more than twice as high as the maximum frequency of original signal, then the original signal can be retrieved by A/D and D/A conversion. With CDs, the sampling frequency is 44.1kHz, meaning the maximum frequency is band-limited to 22.05kHz. Therefore, the information on the waveform for over-22.05kHz frequencies is not transmitted.

Unless it's sinusoidal, a signal contains multiple high-order harmonics. So does a square wave. If the input is a 1kHz square wave signal, it retains its shape because much of the information on the waveform for harmonics is retained after the A/D and D/A conversion. But if the input is a square wave of a high frequency, the converted signal presents a rounded shape because of the absence of information on high frequencies.

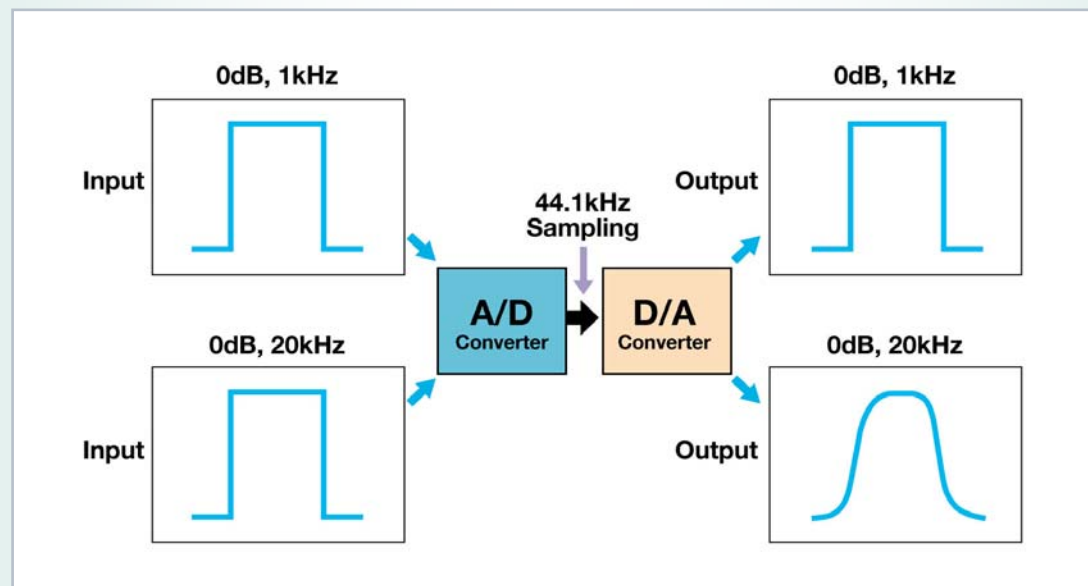
A/D and D/A Conversion in Frequency Domain



The CC Converter was developed to solve the problems with digital conversion by (1) increasing quantization resolution for low-level signals and (2) increasing the sampling frequency for high-frequency signals. Because bit expansion and oversampling alone do not guarantee better sound quality, the CC Converter features JVC's original, advanced digital signal processing.

CC Converter Block Diagram

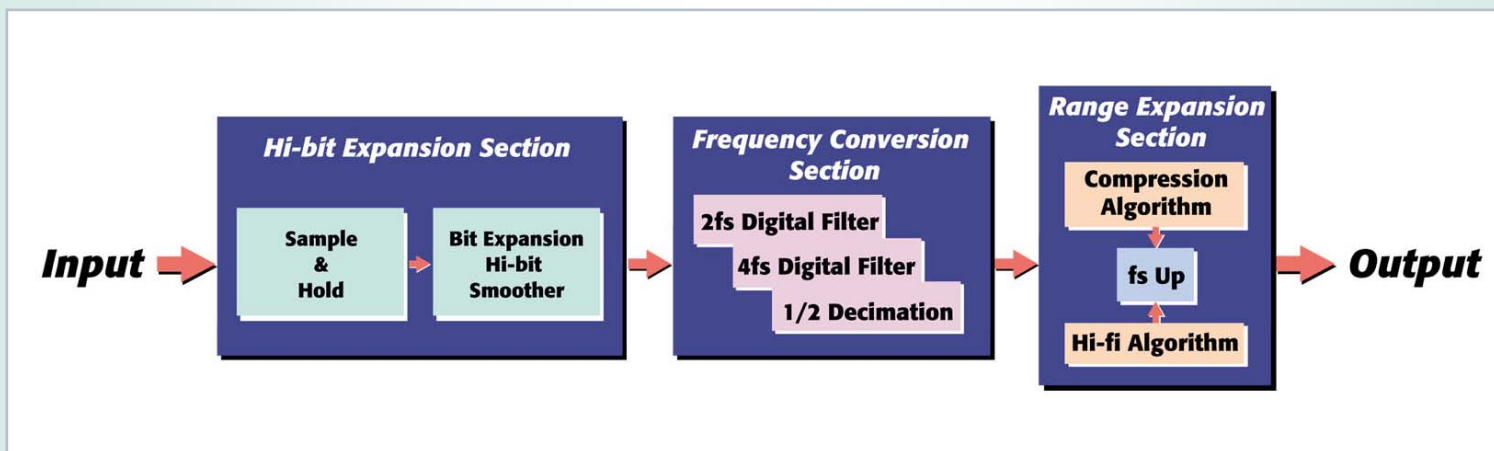



In the bit expansion section, the JVC-exclusive hi-fi processing generates a high-resolution 24-bit digital signal from a 16-bit signal. The process first analyzes the 16-bit digital signal to deduce the original analog signal before A/D conversion, and then applies hi-bit expansion to smooth the signal waveform. What's more, the process ensures that the 24-bit signal preserves the same sound energy of the 16-bit digital signal.

Hi-bit Expansion Processing

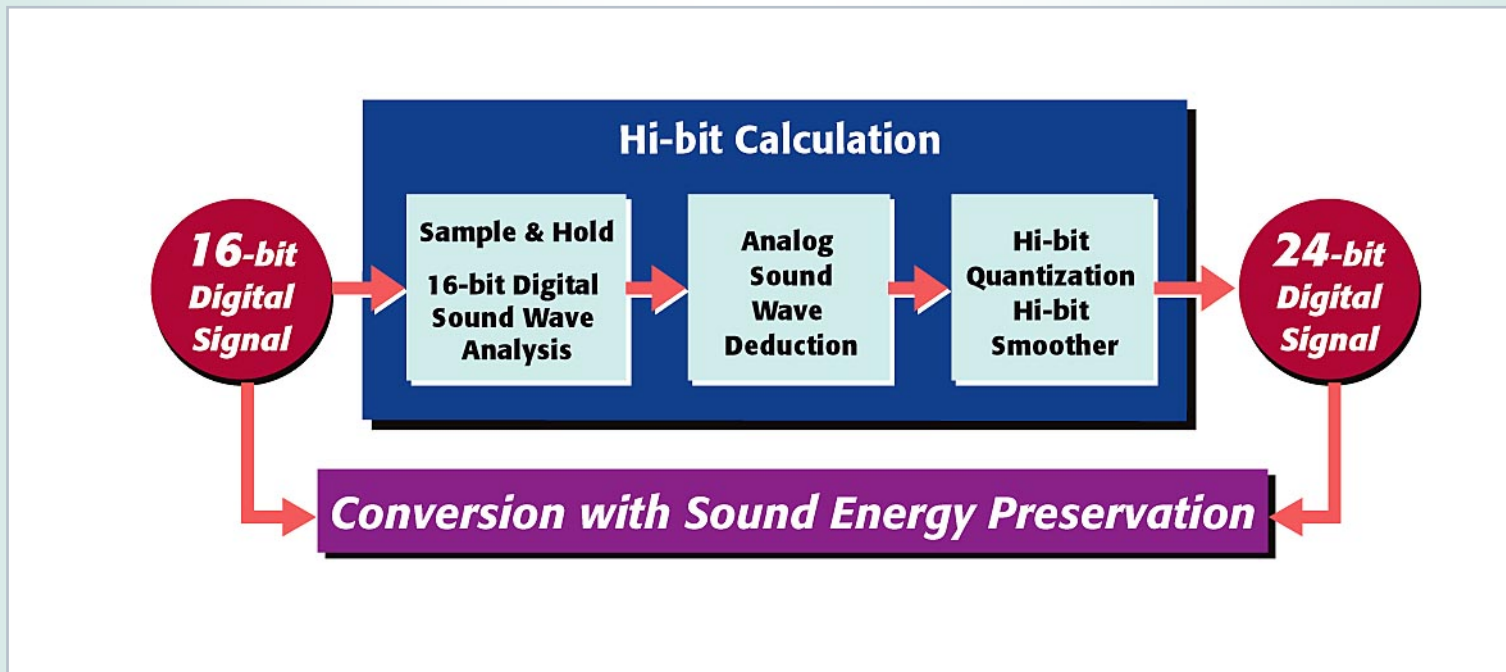



Frequency Conversion Section

RX-D702

The frequency conversion section doubles or quadruples the sampling frequency for playback of high-frequency signals that a following stage generates.

Range Expansion Section

The range expansion section applies the JVC-exclusive range expansion processing to compensate for the conversion distortion that occurs when the analog signal is converted into a digital signal.

The human ear, it is said, cannot hear frequencies above 20kHz, but removing frequencies higher than 20kHz changes the waveform of audible frequencies, resulting in a signal that sounds different from the original. The range expansion section overcomes this problem by deducing the original waveform of a signal before A/D and D/A conversion and modifying the signal's waveform accordingly. For playback of frequencies above 20kHz generated by this waveform processing, the range expansion section has a frequency conversion section preceding it.

Range Expansion Block Diagram

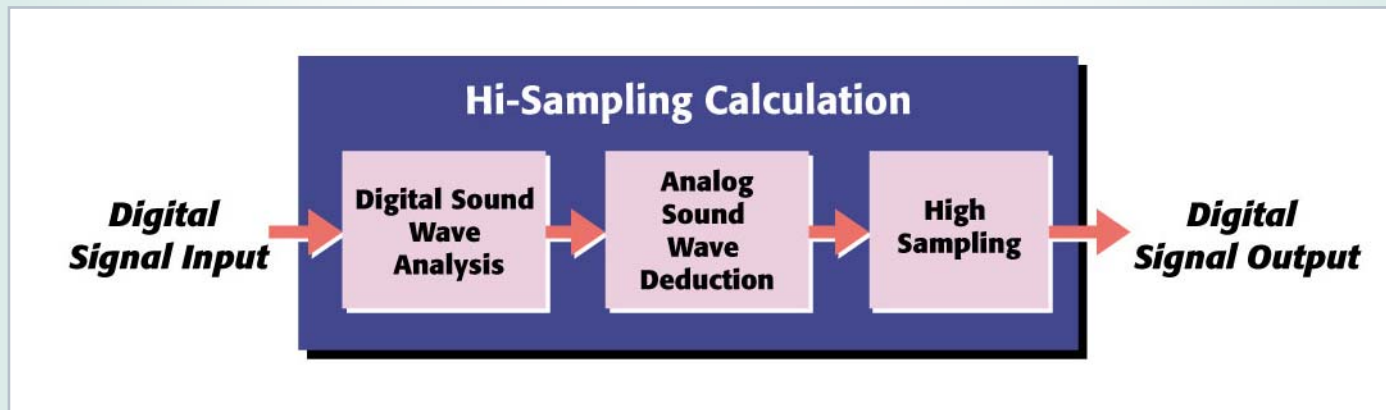



CC Converter: How its workings differ from other high-bit/upsampling systems

RX-D702

There are several high-bit/upsampling processing systems on the market that claim to offer the same benefits as the CC Converter. They are all designed to create and add frequencies (harmonics) over 20kHz deriving from an input signal.

But we do not believe the mechanical addition of harmonics can ensure the faithful recreation of “musicality.” The sound generated by an instrument contains harmonic components. And it is the harmonic components that determine the tone of an instrument. The harmonic components of one violin are different than those of another. One player’s phrasing produces different harmonic components from one by others. Some instruments feature rich resonance, while others produce hardly any.

Therefore, applying the same process for adding harmonic components is not proper in view of “musicality.” Reviewers of European audio magazines are highly critical of this approach. Moreover, the existing high-bit/upsampling processing systems use 2x sampling frequencies -- 88.2kHz for CDs to achieve a 44.1kHz frequency range, or 96kHz for DVD Video to achieve a 48kHz frequency range.

CC Converter

JVC’s CC Converter does not simply create and add harmonic components. It computes the data that was lost during the D/A conversion by taking advantage of JVC’s exclusive algorithms. This means the CC Converter has the processing power to recreate the original signal that should have been recorded -- based on the digital signals for the audible range recorded on a CD.

Accurate D/A conversion and reproduction of the recreated data requires a process to expand the frequency range of the analog signals. The frequency-range expansion of the analog signals to beyond 20kHz results in improved music data for the audible range. The CC Converter expands CD’s frequency range fourfold to 88.2kHz using 176.4kHz (44.1kHz x 4) sampling frequency. With DVD-Video, the frequency range is expanded to 96kHz, while the sampling frequency is 192kHz (48kHz x 4).





Comparison of -90dB, 1kHz Sine Waves: Bit Expansion On vs. Off

RX-D702

The figure shows the actual measured waveform of a bit-expanded -90dB sinusoidal signal.



-90dB, 1kHz Sine Wave: Bit Expansion On



-90dB, 1kHz Sine Wave: Bit Expansion Off



Comparison of Frequency Spectra: Range Expansion On vs. Off

The figure shows the frequency spectra of a music signal with the range expansion on and off. With the expansion off, the level is sharply reduced beyond 22kHz. But with the expansion on, the level is naturally extended beyond 22kHz and higher.



RX-D702

LINEAR MODE (for CDs, DVDs, etc.)

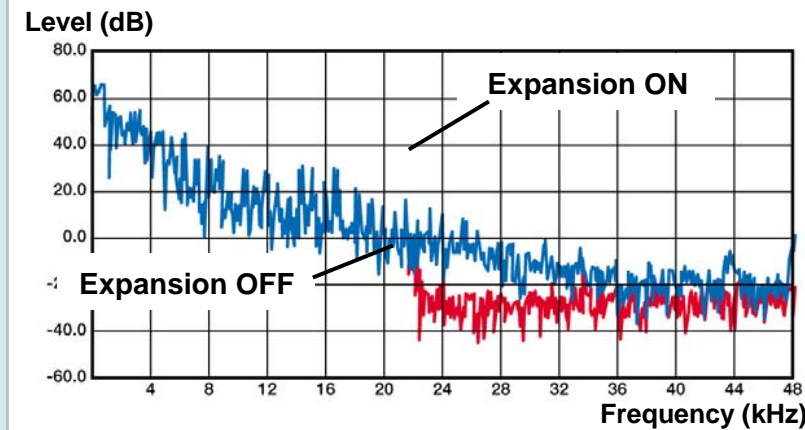

COMPRESSION MODE (for MP3, WMA, etc.)

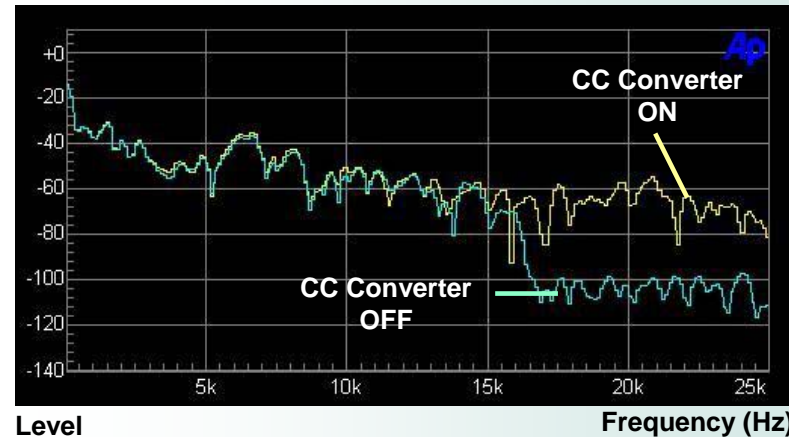



D.D. Converter

RX-D702

RX-D402

*Also applies to RX-D401

The JVC exclusive D/A converter turns the 192kHz/24-bit output into an analog signal with impeccable accuracy.

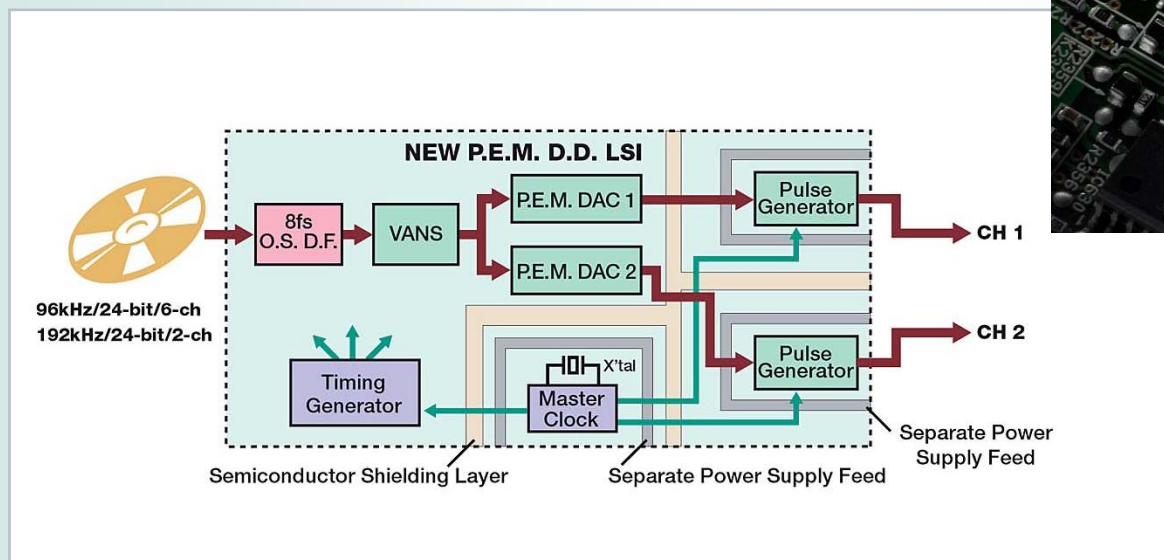
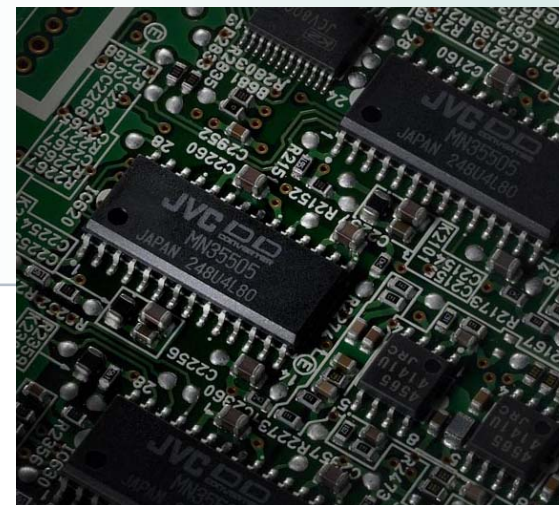



Noise Shaping Response/Noise Spectrum

RX-D702

RX-D402

*Also applies to RX-D401

Noise Shaping Response (Theoretical)

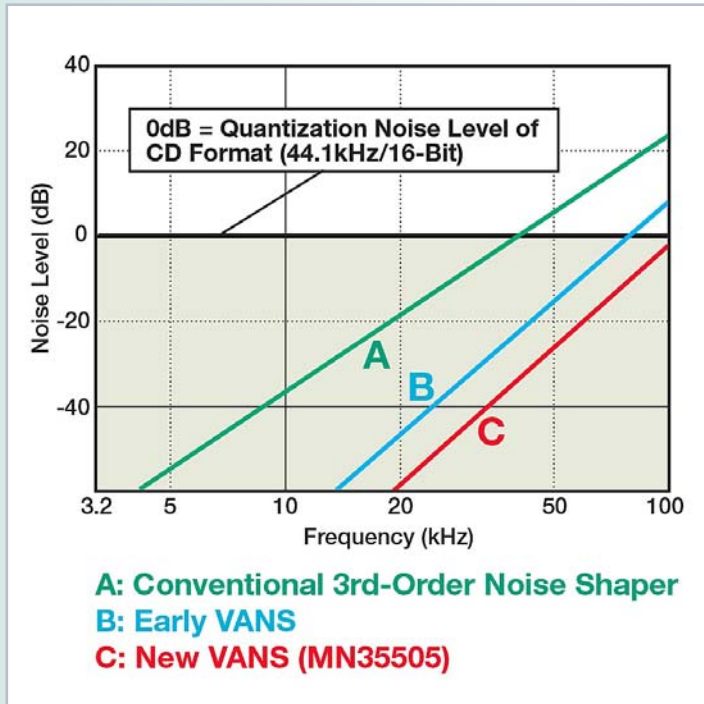

VANS=JVC Advanced Noise Shaper



Noise Spectrum

Conventional D/A Converter

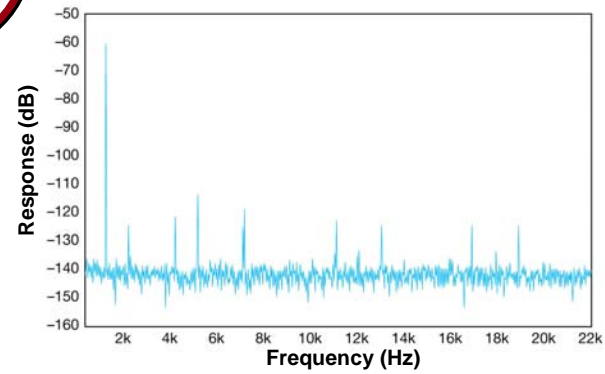

P.E.M. D.D. Converter

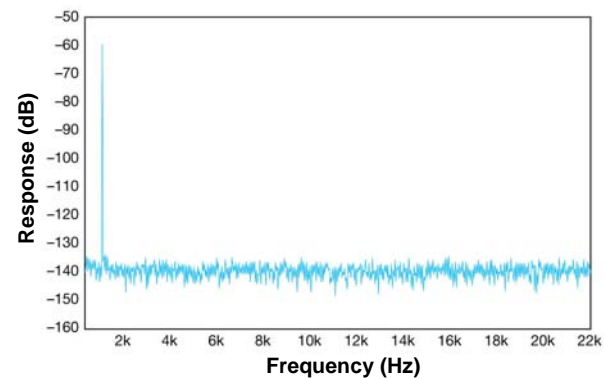



192kHz/24-bit and 96kHz/24-bit A/D Converters -- RX-D702

RX-D702

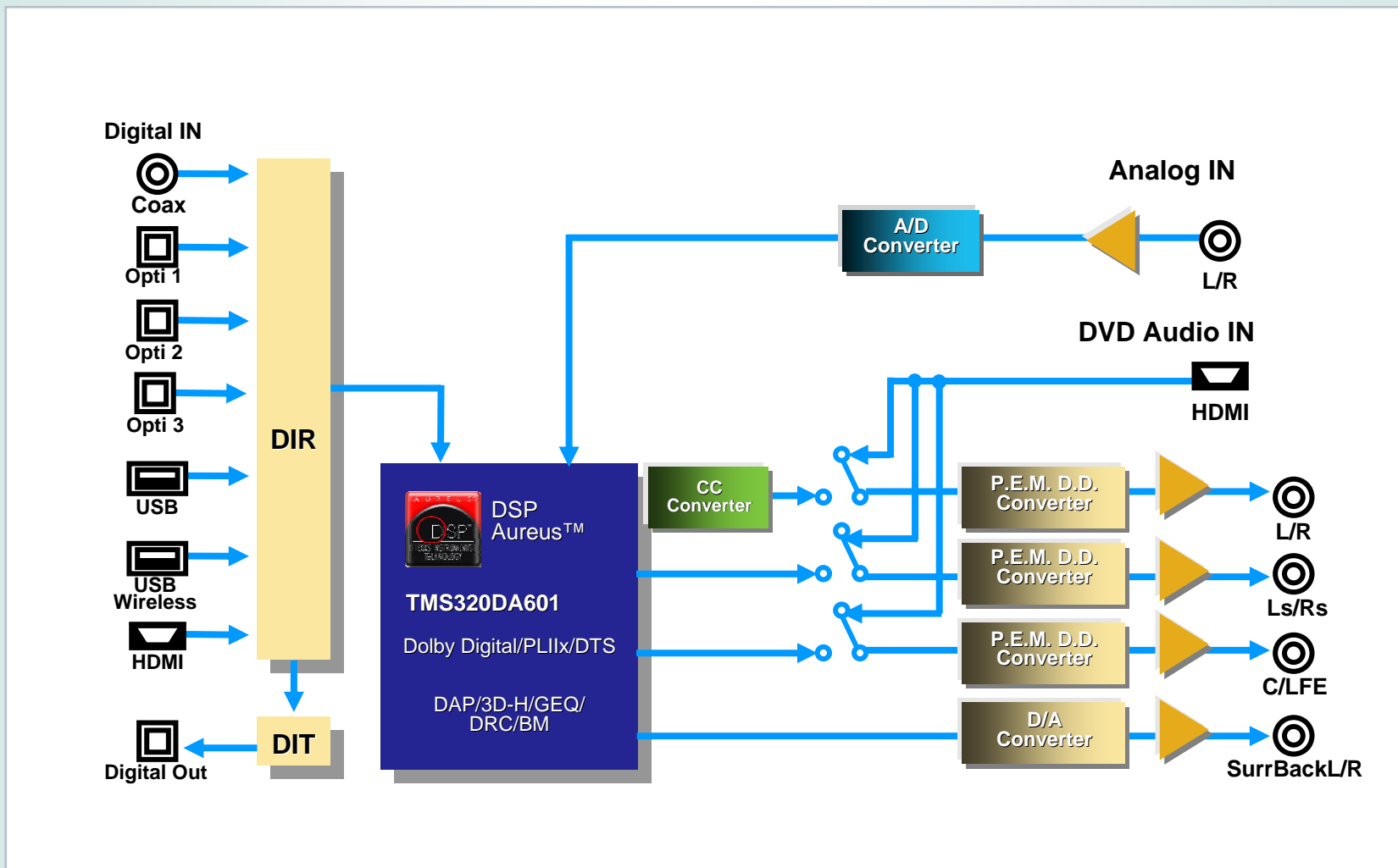



192kHz/24-bit and 96kHz/24-bit A/D Converters -- RX-D402/D401

RX-D402

*Also applies to RX-D401

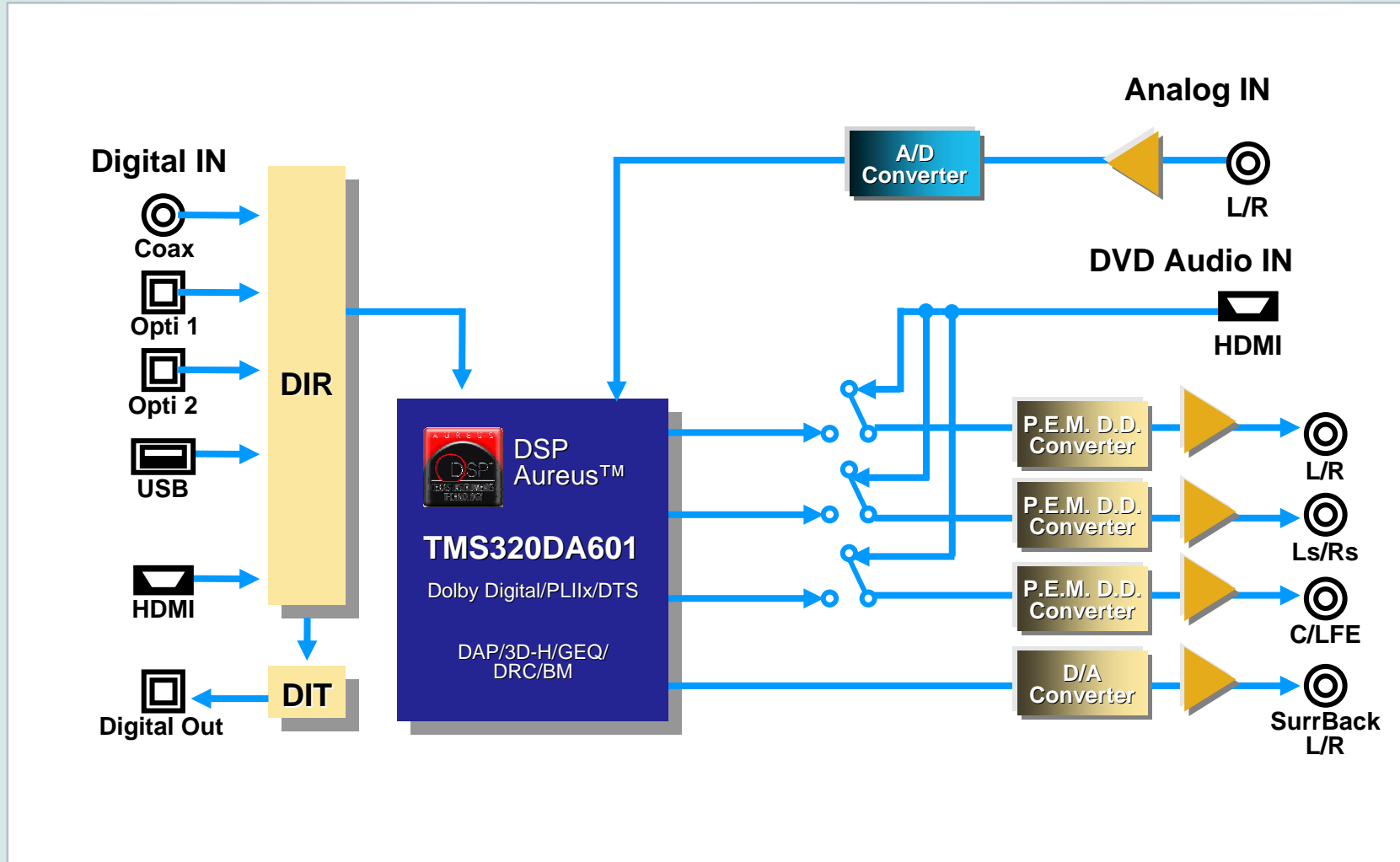

4 Aureus™ -- High-Performance DSP for Superior Sound Quality



JVC exclusive DSP -- implemented by the Texas Instruments “Aureus”™ DSP -- simulates the acoustics of music venues. In doing so, it makes use of a vast amount of DSP-computed data for the creation of sound field patterns that conventional processing systems, based on field-measured impulse responses, have difficulties recreating. With JVC’s DSP, the sound fields are reproduced most naturally, with early reflections simulated realistically. More than ten years ago, JVC sent engineers worldwide to measure the acoustics of famous theaters and concert halls. JVC exclusive DSP embodies both the old know-how and latest technologies to make you feel you are there.

JVC exclusive DSP

Texas Instruments Floating-Point DSP -- Aureus™ (TMS320DA601)	32
JVC’s DSP	33
Sound Field Analysis (Ray Tracing)	34
The reason why sound field simulation by DSP produces better results than one based on actual measured environments.	35
DAP Modes (1)	36
DAP Modes (2)	37
5-Band Graphic Equalization	38
3D Headphone	39
Midnight Mode	40
Center-Channel Alignment	41
Smart Surround Setup	42



Texas Instruments Floating-Point DSP -- Aureus™ (TMS320DA601)

RX-D702

RX-D402

*Also applies to RX-D401

At the heart of the RX-D702/D402/D401's DSP is a new high-performance Texas Instruments DSP -- Aureus™. It's the world's fastest, highest-performing chip of its kind now, replacing two conventional DSP chips. The JVC receiver is the world's first to feature this LSI.

Features

- 1,800MIPS* or 1,350MFLOPS** (at 225MHz clock speed) -- one of the highest processing power ratings on the market
- 32-bit (64-bit double precision) accurate operations
- Decode formats: Dolby Digital, Dolby Digital EX, Dolby Pro Logic IIx, DTS, DTS-ES, DTS 96/24, DTS NEO:6
- Functions: DAP, 3D-PHONIC, 3D Headphone, DSP Digital Equalizer, Dynamic Range Control, Bass Management

Advantages

- A single chip performing DTS 96/24 processing and DAP (Digital Acoustics Processing) with power to spare
- More accurate implementation of simulated DAP sound fields
- Compact size conducive to reduction in digital noise
- Floating-point operations for more accurate calculations with an expanded range of numbers

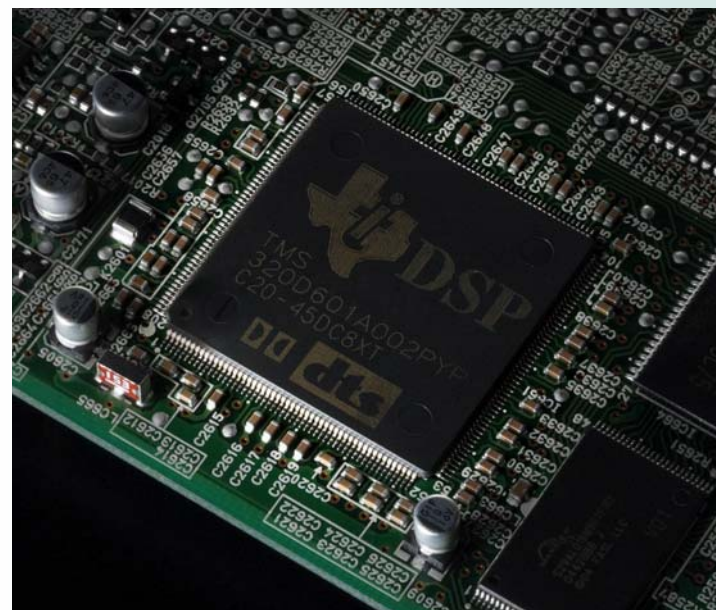

* FLOPS (Floating Point Operations per Second): the number of floating-point calculations per second performed with real numbers.

** MIPS (Million Instructions per Second): A 1MIPS computer processes 1 million instructions per second. An "instruction" is a command sent out to a DSP to directly control and operate it. A DSP executes instructions stored in memory, makes calculations and outputs the result. The number represents a DSP or CPU's capability of computing -- the greater the power of processing.



JVC's DSP

Listening to the 7.1-channel surround as processed by the JVC DAP (Digital Acoustics Processor) evokes a totally different surround sound experience from what you get from stereo or 5.1-channel sound. Listen carefully to the 5.1-channel sound of a DVD in its recorded form and you'll notice it does not produce the sensation of being surrounded by sound.

JVC developed the DAP for one objective: to make the home theater audience feel as if they were in the best movie theater surrounded by an array of speakers to the left and right, and behind. Then they would feel enveloped in sound, with a helicopter, for instance, moving left to right, or front to back.

JVC exclusive DSP, as implemented by the TI Aureus™ chip -- embodies the algorithms of sound field recreation that are developed specifically for advanced home theater receivers. The sound field patterns are created on the basis of the computer sound field simulation technology developed by a leading concert hall construction company. Patterns of reflections are calculated based on the data of the sound fields of the concert halls, theaters and movie theaters.

*To verify simulated halls, the contractor creates a precision scaled-down miniature hall using the same materials for walls, seats, etc., in the same shape. A second larger scaled-down model will then be made to further refine the data.

RX-D702

RX-D402

*Also applies to RX-D401

Stereo Playback

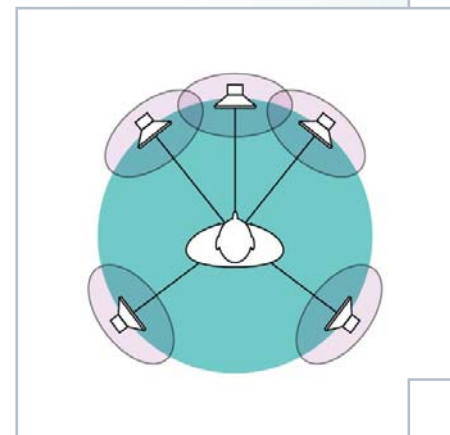
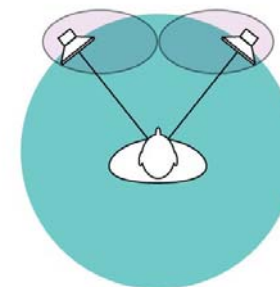

5.1-channel Playback

7-Channel DAP Playback

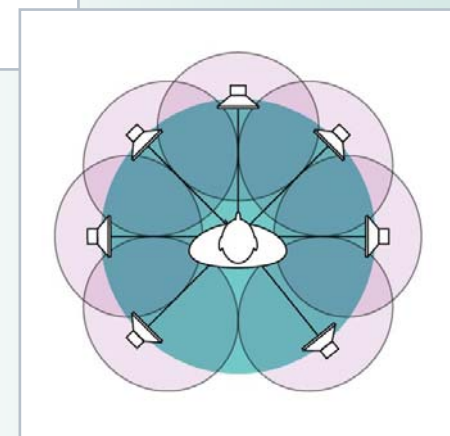



Sound Field Analysis (Ray Tracing)

RX-D702

RX-D402

*Also applies to RX-D401

The figure shows the paths of the “sound rays” as they propagate from a sound source (red, black and brown balls) to the receiver (blue ball). The DSP calculates the properties of a reflection sound (time delay and direction) from the paths of the sound rays. The simulation computations it does for 7.1-channel surround are different from those for 5.1-channel surround or for stereo. This means the DSP does optimal simulation computations according to the configuration of speaker setting.

- Blue ball:** receiver’s position (seating position)
- Brown ball up front:** sound source (stereo 2-channel)
- 3 red balls up front:** sound source (left, right and center channels)
- 2 red balls in the rear:** sound source (surround left and right channels) (5.1-channel surround consists of five red balls.)
- 4 green balls** to the sides and in the rear: 7.1-channel surround consists of three red balls and four black balls.

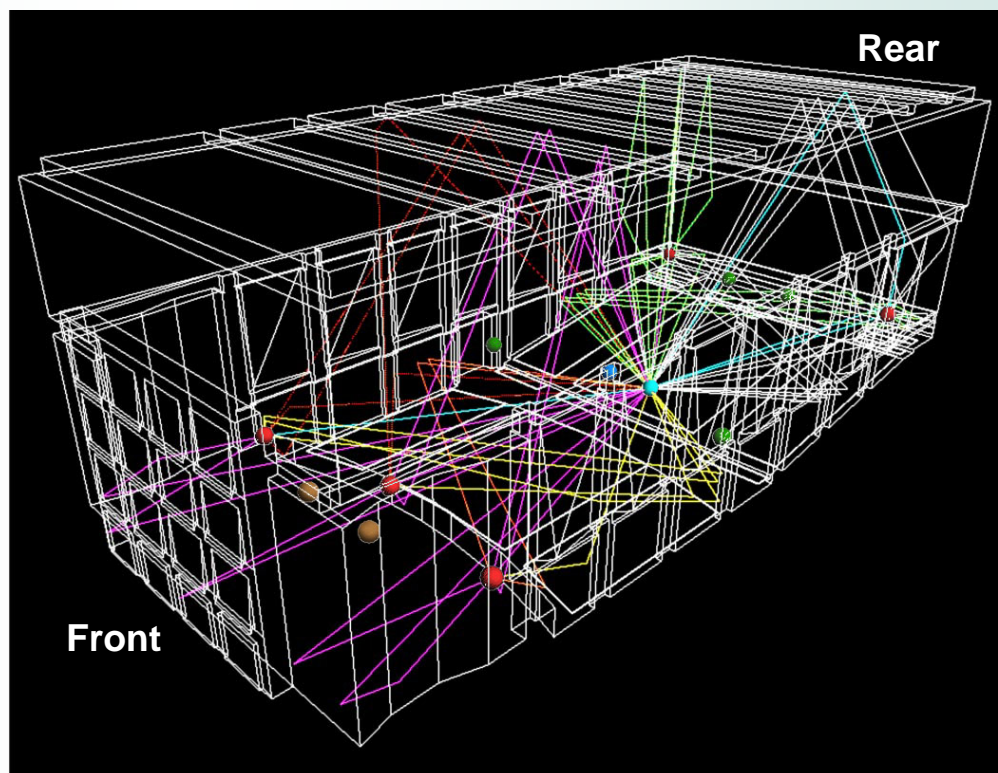



The reason why sound field simulation by DSP produces better results than one based on actual measured environments.

RX-D702

RX-D402

*Also applies to RX-D401

To recreate an environment's sound field, a real hall or cinema's sound field is measured for data. For measurements, a pulse noise is emitted, its direct and indirect sounds are picked up by microphones, and their data is recorded. This is the approach adopted by other home theater receiver/processor manufacturers.

But measuring the sound field of an existing environment entails inaccuracies in the methodology. For instance, microphones have different characteristics, from model to model and from unit to unit. The measured data gives clues to time and level of a sound, but not to the direction. Measurements are made only at selected spots. Softest sounds are not captured accurately.

Sound field simulation by DSP, on the other hand, can produce accurate data by supplying parameters, such as the shape of a hall, the shape and acoustic properties of interior materials, and the presence/absence of an audience. Because this data is not based on actual measurements that could be affected by the measuring equipment used or its inaccuracy, it allows the accurate recreation of the frequency response and even the direction of each reflection.

Impulse Response

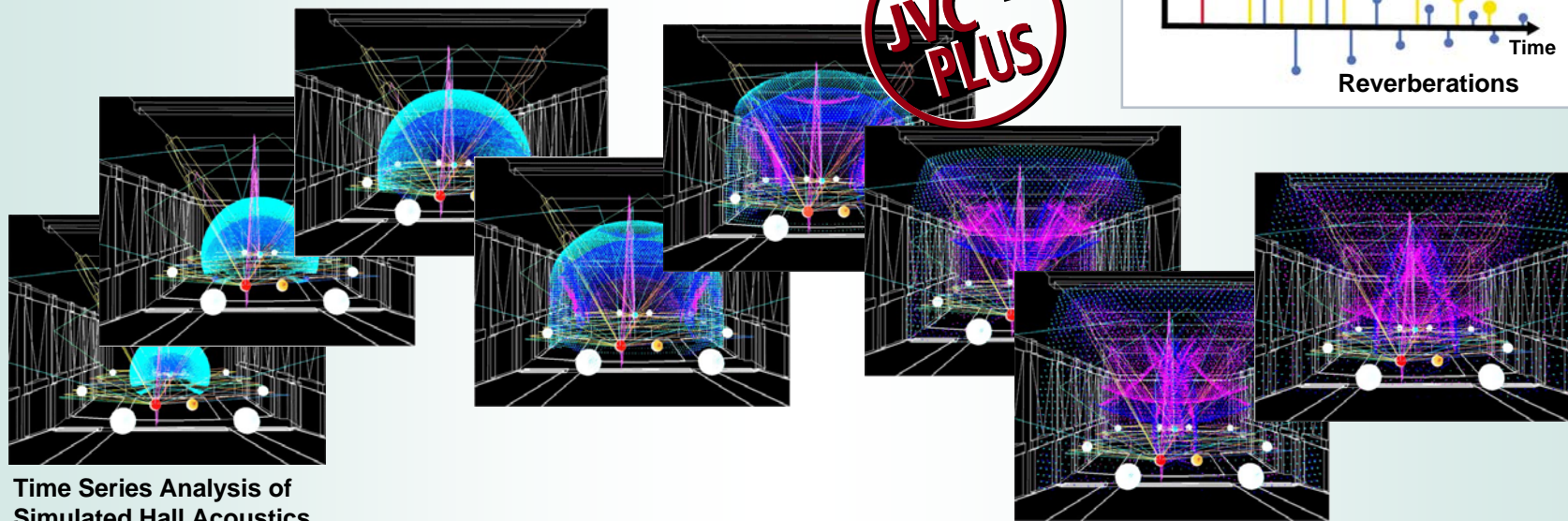
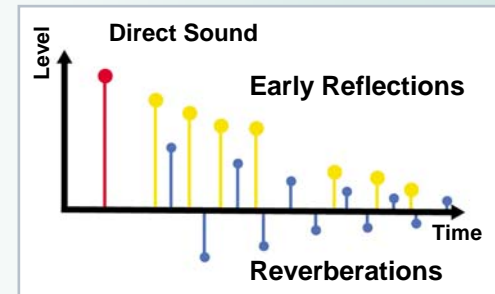

Time Series Analysis of Simulated Hall Acoustics



DAP Modes (1)

RX-D702

RX-D402

*Also applies to RX-D401

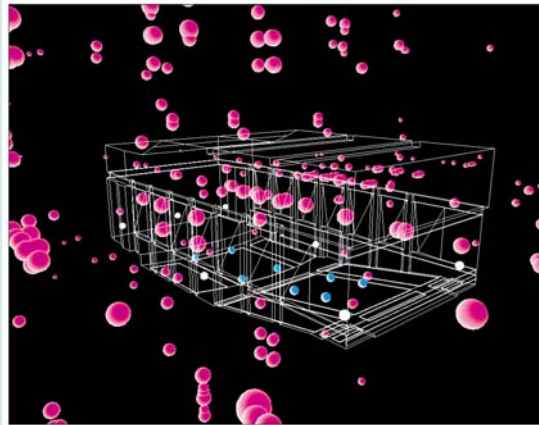

THEATER 1

Capacity: 6,500m³ Seats: Approx. 600
Reverberation: 1.23 sec.

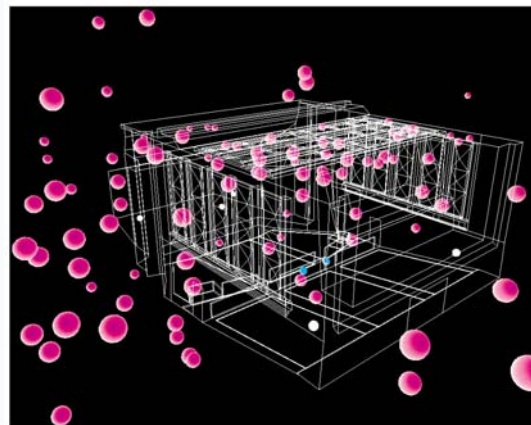

THEATER 2

Capacity: 2,000m³ Seats: Approx. 300
Reverberation: 0.55 sec.

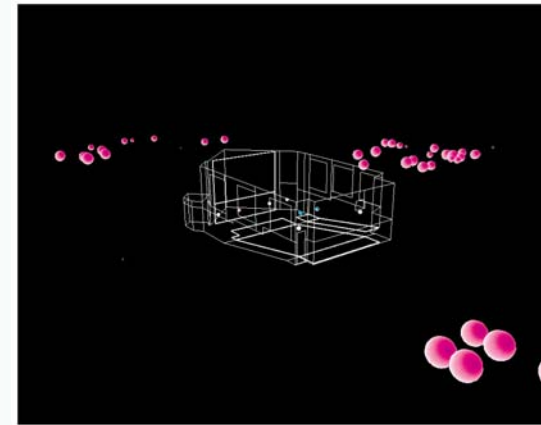

LIVE CLUB

Capacity: 400m³ Seats: 70
Reverberation: 0.35 sec.

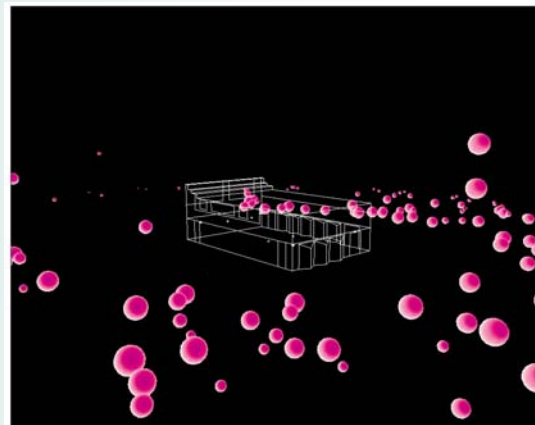

DANCE CLUB

Capacity: 2,200m³ Seats: 240
Reverberation: 0.55 sec.

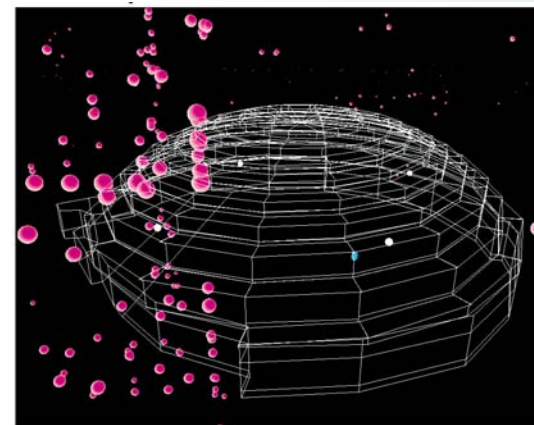

PAVILION

Capacity: 549,700m³
Reverberation: 5.22 sec.



DAP Modes (2)

RX-D702

RX-D402

*Also applies to RX-D401

DAP Modes for RX-D702/D402/D401

Mode	Signal	DTS		Dolby Digital		Linear	Analog
		5.1 ch	2 ch	5.1 ch	2 ch	PCM	
Multi-Channel DAP	HALL 1	●*	-	●*	-	-	-
	HALL 2	●*	-	●*	-	-	-
	LIVE CLUB	●*	-	●*	-	-	-
	DANCE CLUB	●*	-	●*	-	-	-
	PAVILION	●*	-	●*	-	-	-
	THEATER 1	●*	-	●*	-	-	-
	THEATER 2	●*	-	●*	-	-	-
Pro Logic II Movie+DAP	THEATER 1	-	●*	-	●*	●*	●*
	THEATER 2	-	●*	-	●*	●*	●*
DAP	HALL 1	-	●*	-	●*	●*	●*
	HALL 2	-	●*	-	●*	●*	●*
	LIVE CLUB	-	●*	-	●*	●*	●*
	DANCE CLUB	-	●*	-	●*	●*	●*
	PAVILION	-	●*	-	●*	●*	●*
	MONO FILM	-	●*	-	●*	●*	●*
3D Headphone		●	●	●	●	●	●
3D Phonic		●	●	●	●	●	●
All Ch. Stereo		●	●	●	●	●	●

*When the SURR. BACK SPK. setting is "ON", the DAP performs 7-channel processing, outputting reverberation components to Surround Back channels.

Mode	For Recreation of Spatial Feel of :
HALL 1	Large shoebox-shaped hall designed primarily for classical concerts
HALL 2	Large vineyard-shaped hall designed primarily for classical concerts
LIVE CLUB	Live music club with a low ceiling
DANCE CLUB	Rocking dance club
PAVILION	Exhibition hall with a high ceiling
THEATER 1	Large movie theater
THEATER 2	Small movie theater
MONO FILM	For 3D-like reproduction of classic movies with mono soundtracks



5-Band Graphic Equalization

RX-D702

RX-D402

*Also applies to RX-D401

A graphic equalizer lets you adjust the levels of center frequencies.

An analog equalization circuit is built from resistors and capacitors, therefore noise and phase reversal are inevitable. A digital equalization circuit performs its function in the entirely digital domain. Clarity and consistent definition are its advantages.

The TI Aureus™ chip ensures high-speed processing for equalization, while it executes various decode processing (Dolby Digital, dts, etc.)

- Center Frequencies: 63Hz, 250Hz, 1kHz, 4kHz, 16kHz
- Level: ± 8 dB, 2dB steps
- 1 manual EQ setting for each source

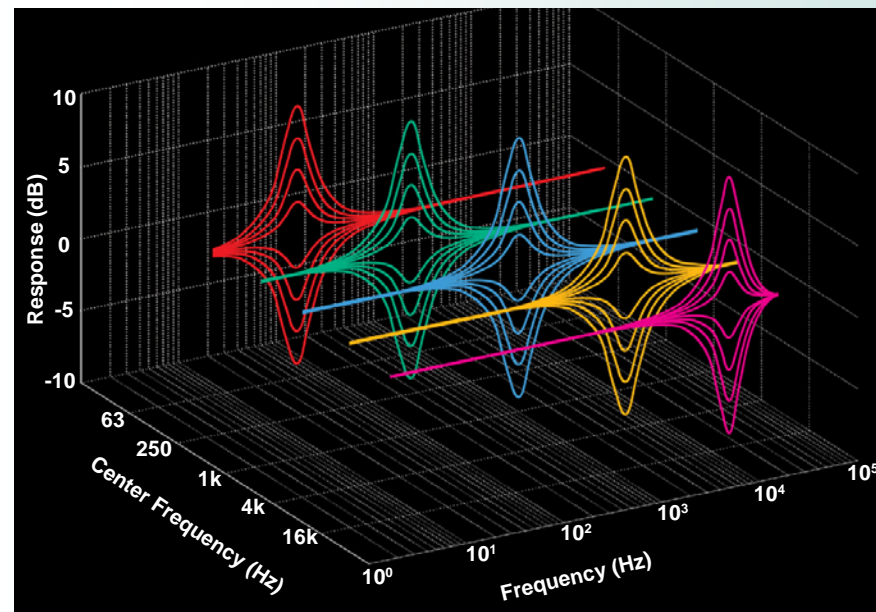
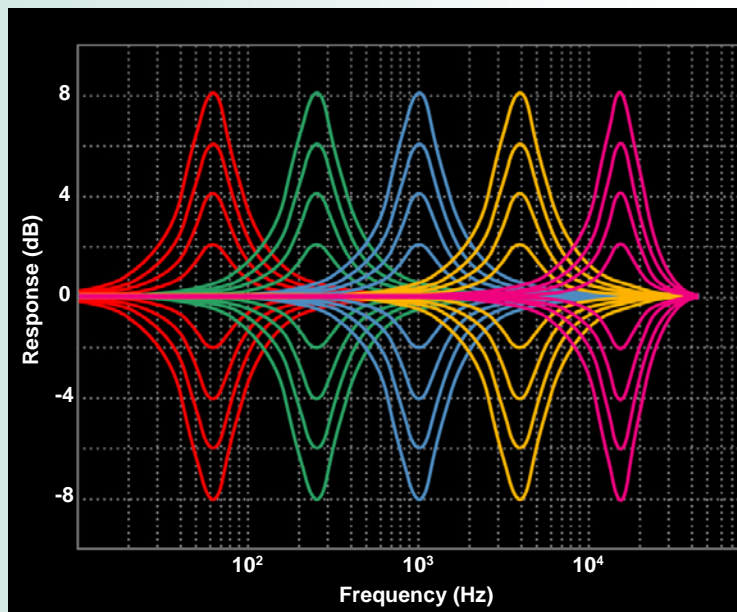



3D Headphone

RX-D702

RX-D402

*Also applies to RX-D401

In a typical listening room, sound from speakers you perceive consists of three elements: direct sound, early reflections (echoes from walls/ceiling/floor), and reverberation. These elements let you locate the sound source and recognize its size. This is called Head Related Transfer Function (HRTF).

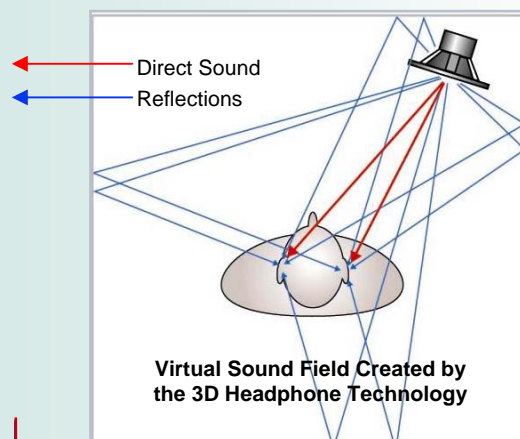
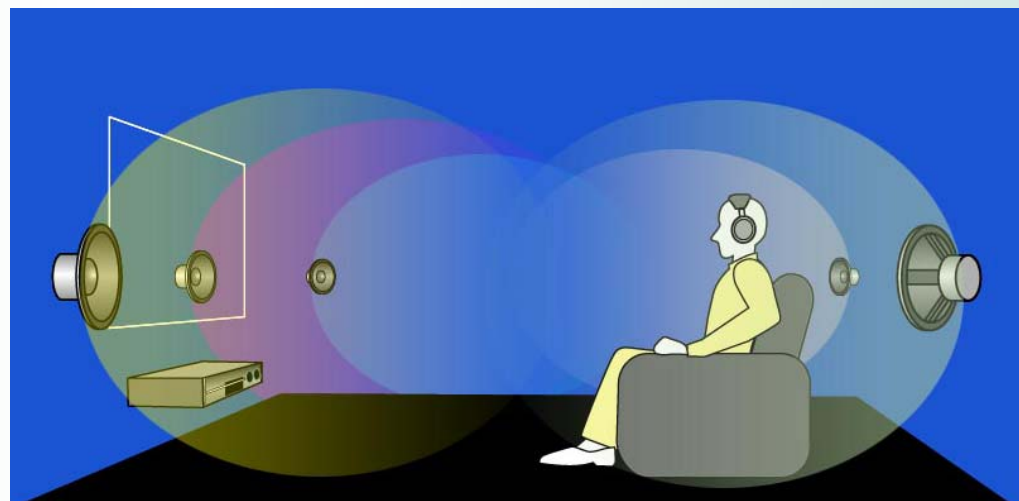

Sound Frequencies Detected in a Typical Listening Room

In developing the 3D Headphone technology, JVC has applied an exclusive algorithm that divides the audio signals into the same three elements and conducts processing individually (convolution processing). This ensures that sound from headphones has the same realism, dynamism, and localization as that from multi-channel speakers.

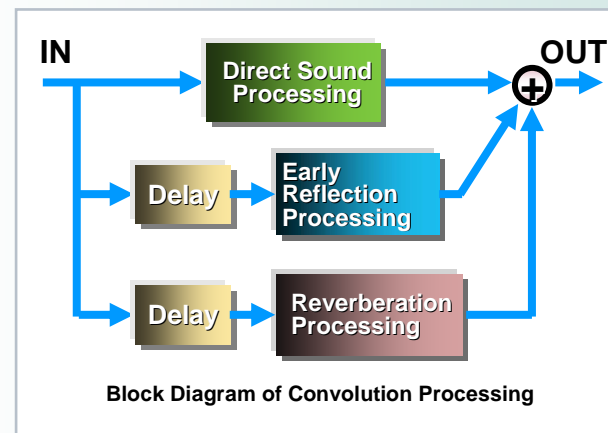



Midnight Mode

RX-D702

RX-D402

*Also applies to RX-D401

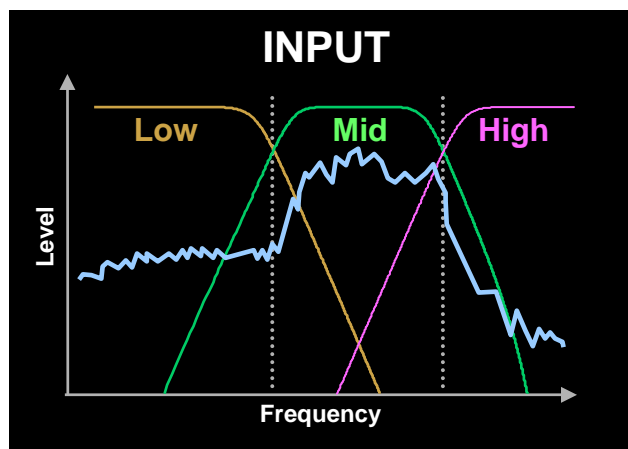

Midnight Mode Processing

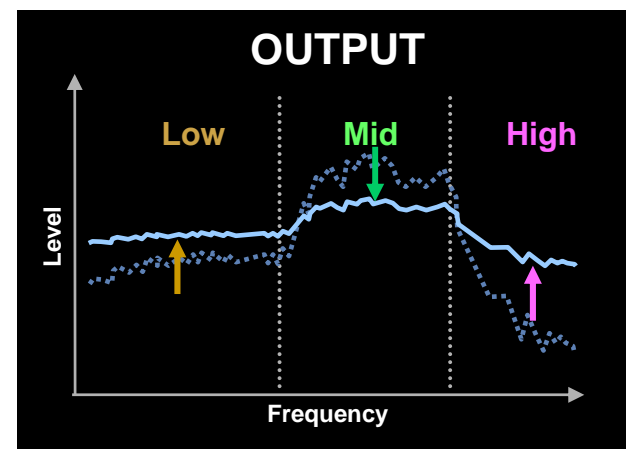

Frequencies of Input/Output Audio Signals

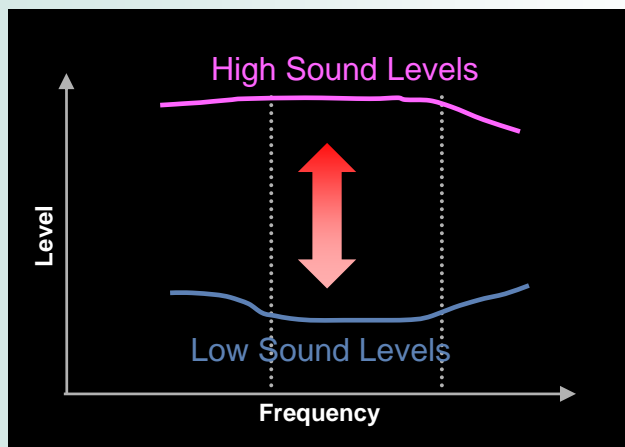

Frequency of Output Signals

The DSP divides input signals into three bands (LOW/MID/HIGH), and processes the signals so that low-level sound in each band will get louder and loud sound will be moderated. This makes the output sound clear across the range, regardless of the original levels.

In addition, the unit individually controls the sound compression level of each band. When the sound level is low, the compression levels of high and low frequencies are raised to deliver enough loudness. When the sound level is high, the gains of the two frequencies are moderated to prevent excessive bass and treble output.

These technologies combine to retain the excitement of multi-channel sound and keep dialog sound clear even at low sound levels. The technologies are applied even when the sound level is lowered suddenly, which is especially useful for midnight viewing, for example.



Center-Channel Alignment

RX-D702

RX-D402

*Also applies to RX-D401

The center speaker is usually placed on top of or under the display, while the front speakers are set at or near ear level. The result is that dialog, carried by the center speaker, seems out of place relative to music and sound effects. JVC's exclusive DSP application virtually positions the center speaker to align it with other speakers with respect to height. The dialog simply sounds more natural.

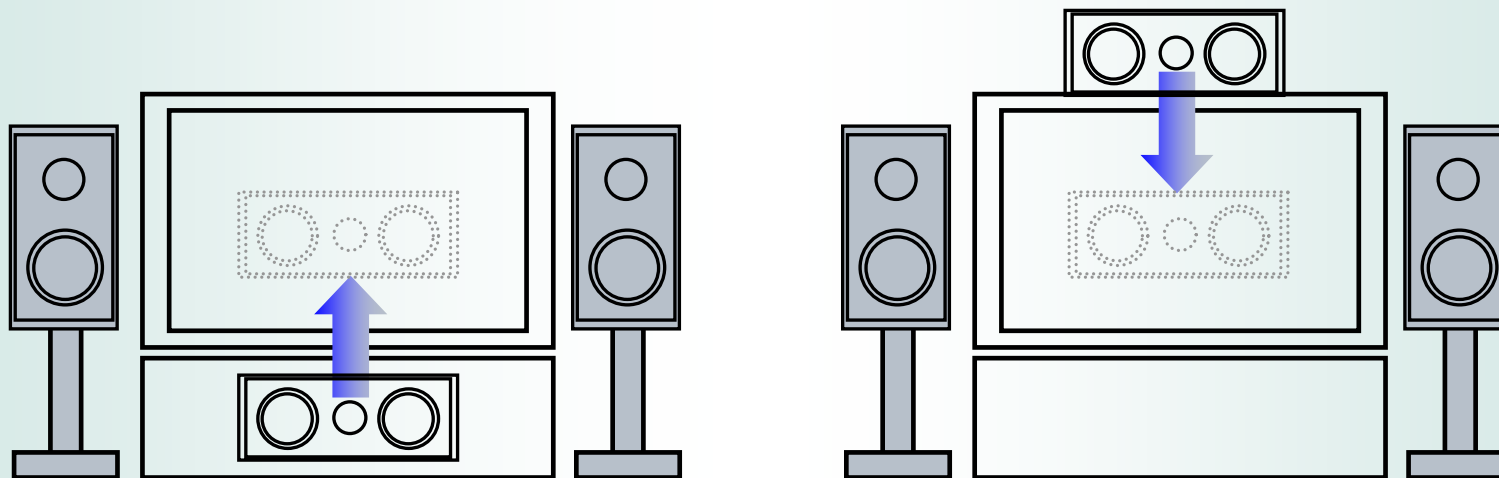

Virtual Repositioning of the Center Speaker with Center Channel Alignment



Smart Surround Setup

RX-D702

Setting up a home theater can be time-consuming and even confusing. Normally, you have to check which speaker channels (front, center, surround, and surround back) you have installed, the distance of each speaker from the listening position, and the level of each speaker.

But with JVC's Smart Surround Setup Version 3.0, it takes just seconds to set up the acoustic environment of your home theater. Clap your hands, and the delay times of all channels are set individually, and the level of each speaker is automatically trimmed -- optimized for your listening position. You can even fine-tune the settings if you prefer. Setup information is displayed on-screen for easy confirmation.

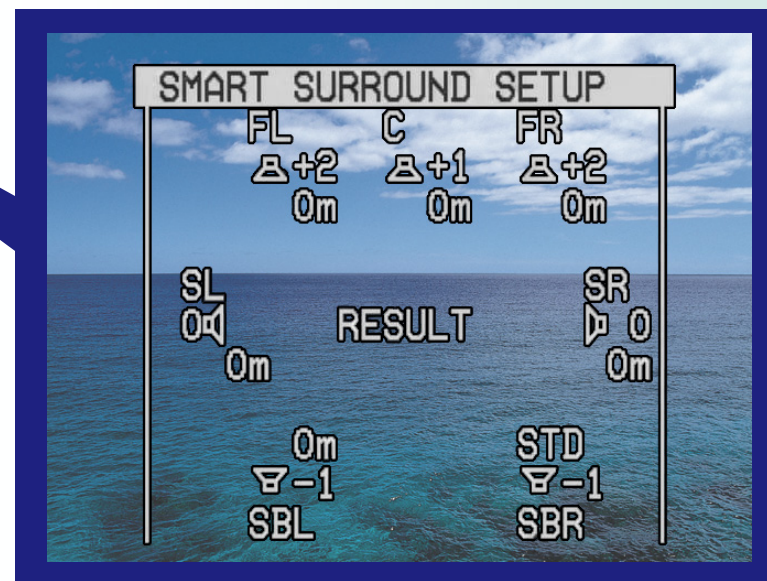
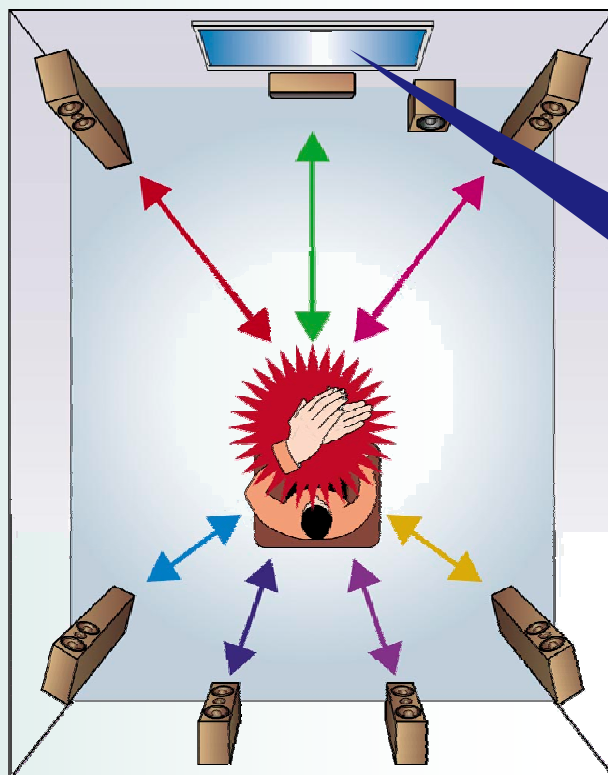

5 Hybrid Feedback Digital Amplifier



JVC-exclusive Hybrid Feedback Digital Amplifier enables a lot more than the compact dimensions of the A/V receivers. Featuring dual analog feedback and digital feedback circuits, this device significantly “brushes up” the input signals, which ensures significantly lowered total harmonic distortion -- to 0.004% -- and superior speaker driveability. The result is high-quality sound matching that from a high-grade analog amp.

The RX-D702 and RX-D402/D401 come with an upgraded “Ver. III” device, which incorporates a wide range of technological improvements for even better sound quality.

Hybrid Feedback Digital Amplifier

Background -- What is PWM?	44
Problems of Digital Amplifiers	45
Evolution of Hybrid Feedback Digital Amplifier (1)	56
Evolution of Hybrid Feedback Digital Amplifier (2)	47
Evolution of Hybrid Feedback Digital Amplifier (3)	48

Hybrid Feedback Digital Amplifier Ver. III -- Technological Improvement for Even Better Sound

Low-Voltage Power Supply	49
One-Chip Solution with JCV8015	50
JCV8015 Benefits (1) -- Operational Amp	51
JCV8015 Benefits (2) -- PWM Modulator/External Clock	52
JCV8015 Benefits (3) -- $\pm 2.5V$ Regulator	53
Quality Parts for Superior Sound Reproduction	54
Comparison of Speaker Driveability	55
T.H.D. Comparison of Digital Amplifiers	56



Background -- What is PWM?

Pulse Width Modulation (PWM) is a method of digitally encoding analog signal levels. In the process, continuously varying value of input audio signals is detected based on the reference voltage (V_{ref}) by comparing the signals with triangular waves. When the value is higher than V_{ref} level, the pulse is switched "ON", and when it gets below V_{ref} , it's turned "OFF". The higher than V_{ref} the value is, the longer the pulse is kept "ON". The lower than V_{ref} the value is, the longer the pulse is left "OFF". Thus, square-shaped waves are generated, representing either "ON" or "OFF" state of the pulse -- length of the "ON" and "OFF" pulses expresses the value of audio signals with respect to the V_{ref} levels. These waves are called "PWM signals". Precision of the PWM signals is one of the elements that determine the sound quality delivered by a digital amplifier. This is why "feedback" process is essential for delivering high-quality sound.

RX-D702

RX-D402

*Also applies to RX-D401

Switching Power Supply with Highly-Efficient Operations

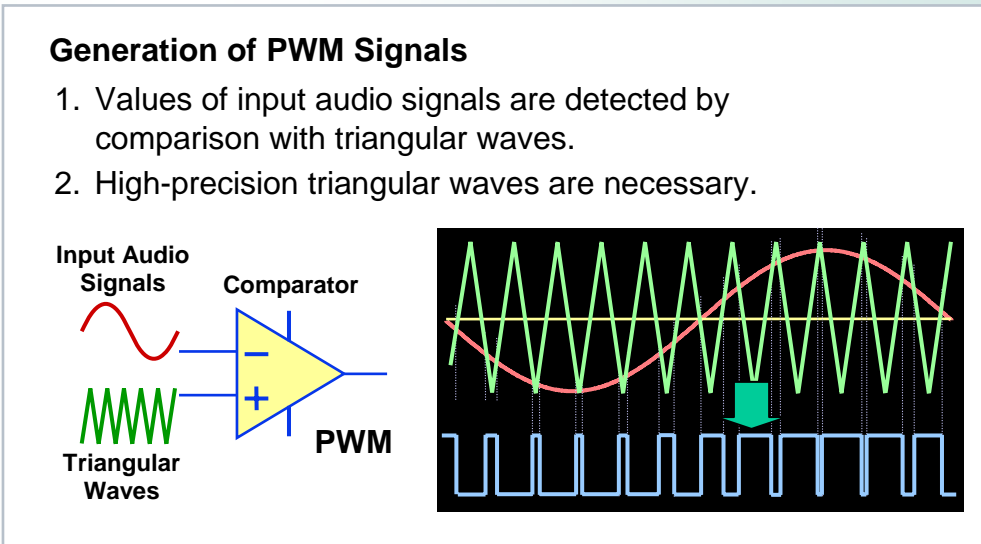
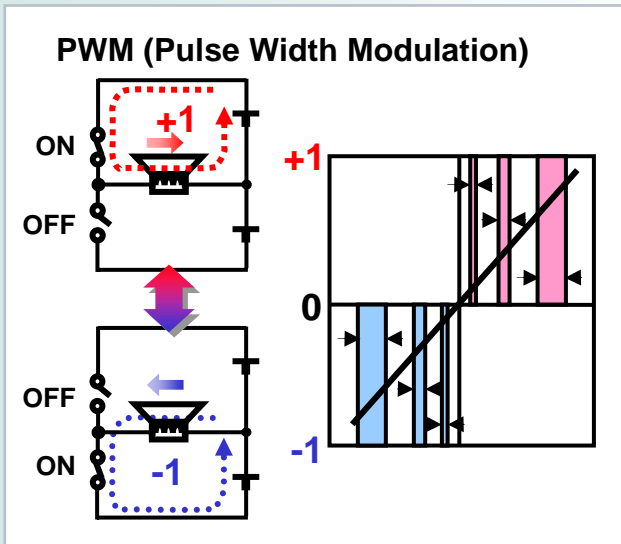
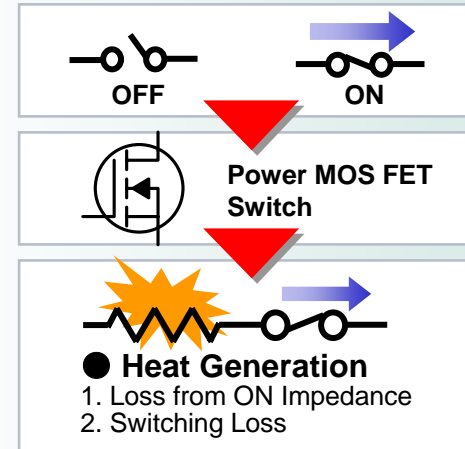



RX-D702

RX-D402

*Also applies to RX-D401

With conventional amplifiers, the mechanism for digital signal processing tends to cause a wide range of noise.

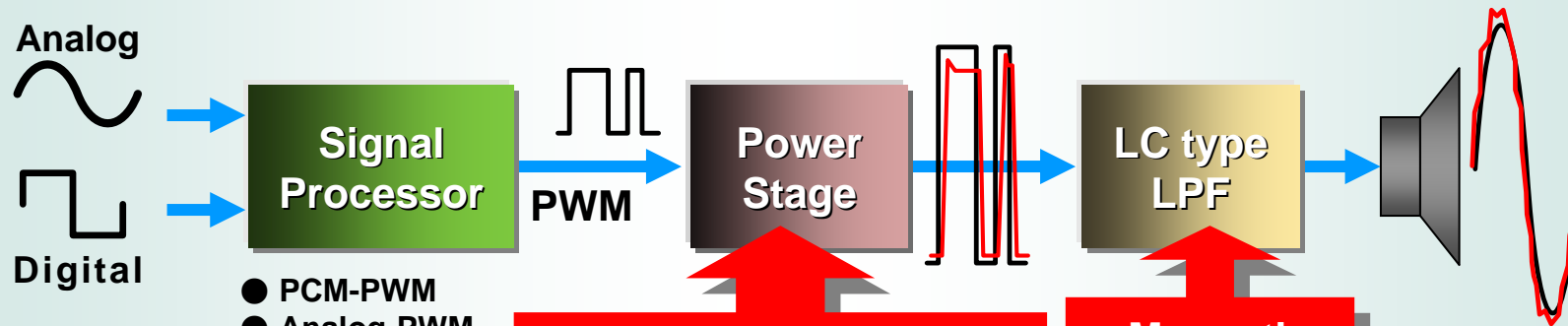

- Slew Rate Fluctuation
- Power Supply Noise
- Dead Time
- EMI

- Magnetic Distortion



Caused at Power Stage and After

*Even when the PWM signals are accurate, a wide range of noise is generated at power stage and after.



RX-D702

RX-D402

*Also applies to RX-D401

Hybrid Feedback Digital Amplifier

Use of two feedback loops eliminates the noise generated at each process:

Digital feedback -- for significantly improving the precision of PWM signal generation.

Analog feedback -- for “brushing up” the waveform of the analog signal at output to match the original.

1

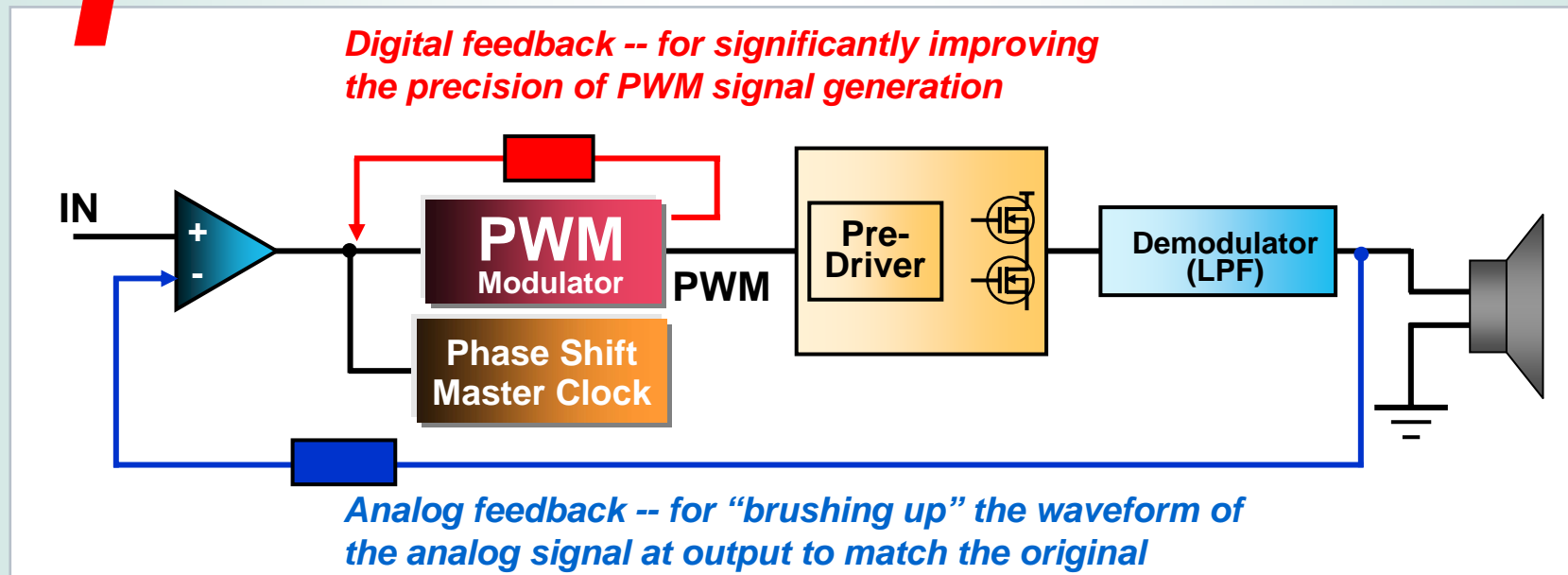



RX-D702

RX-D402

*Also applies to RX-D401

Hybrid Feedback Digital Amplifier Ver. II

Double analog feedback ensures even lower distortion.

2

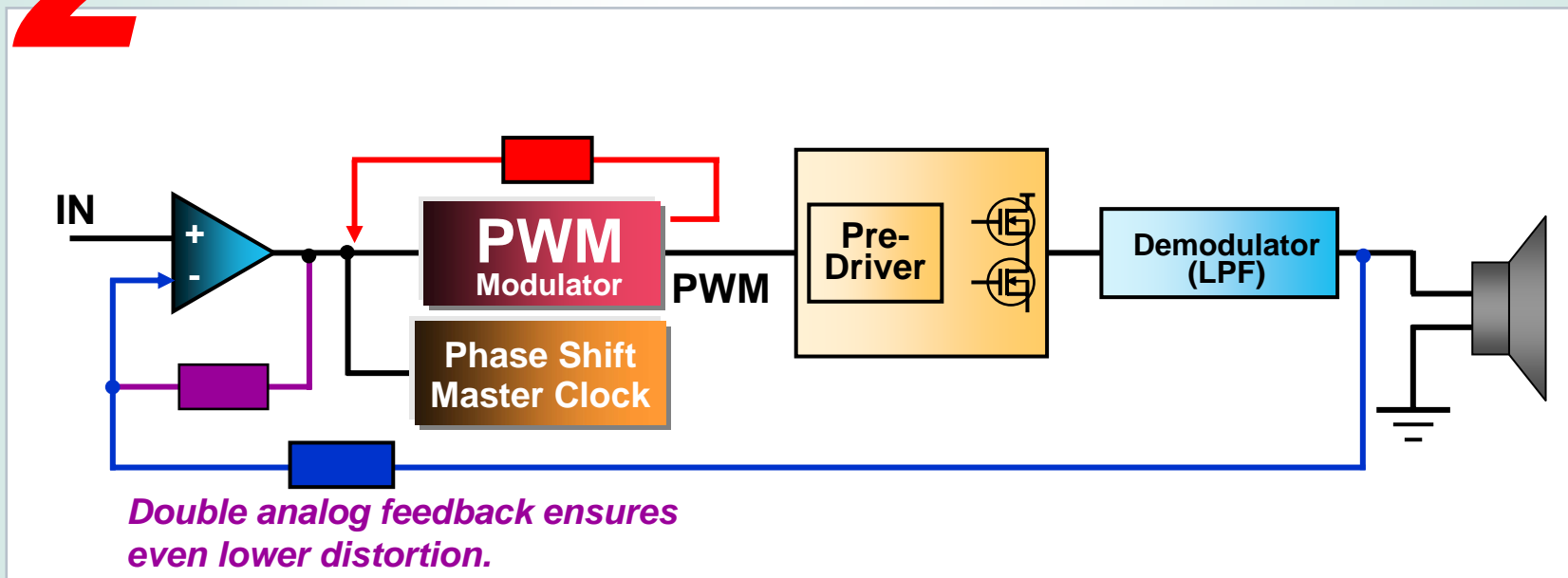



RX-D702

RX-D402

*Also applies to RX-D401

Hybrid Feedback Digital Amplifier Ver. III

Double analog & digital feedback loops for even lower total harmonic distortion.
Use of newly-developed "JCV8015" for containing all the circuits.

3

Double analog & digital feedback loops for even lower total harmonic distortion

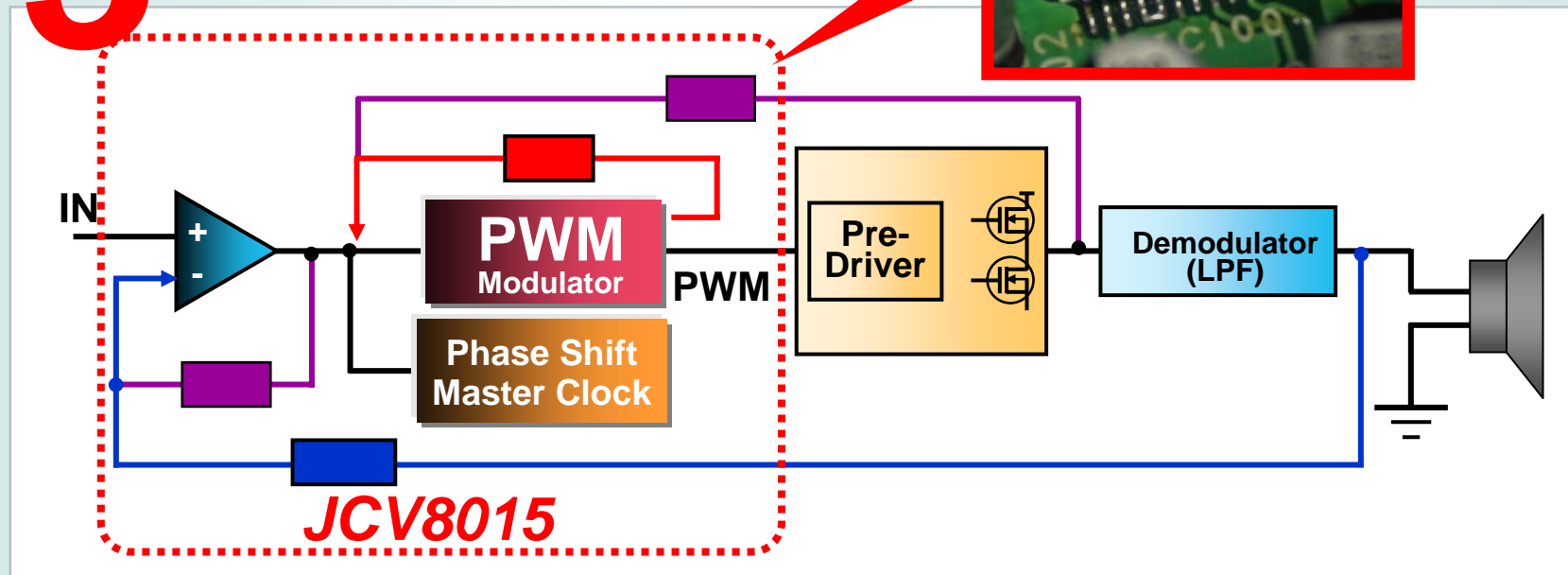



Low-Voltage Power Supply

RX-D702

RX-D402

*Also applies to RX-D401

Hybrid Feedback Digital Amplifier Ver. III also features low voltage power supply, which ensures stable signal transfer.

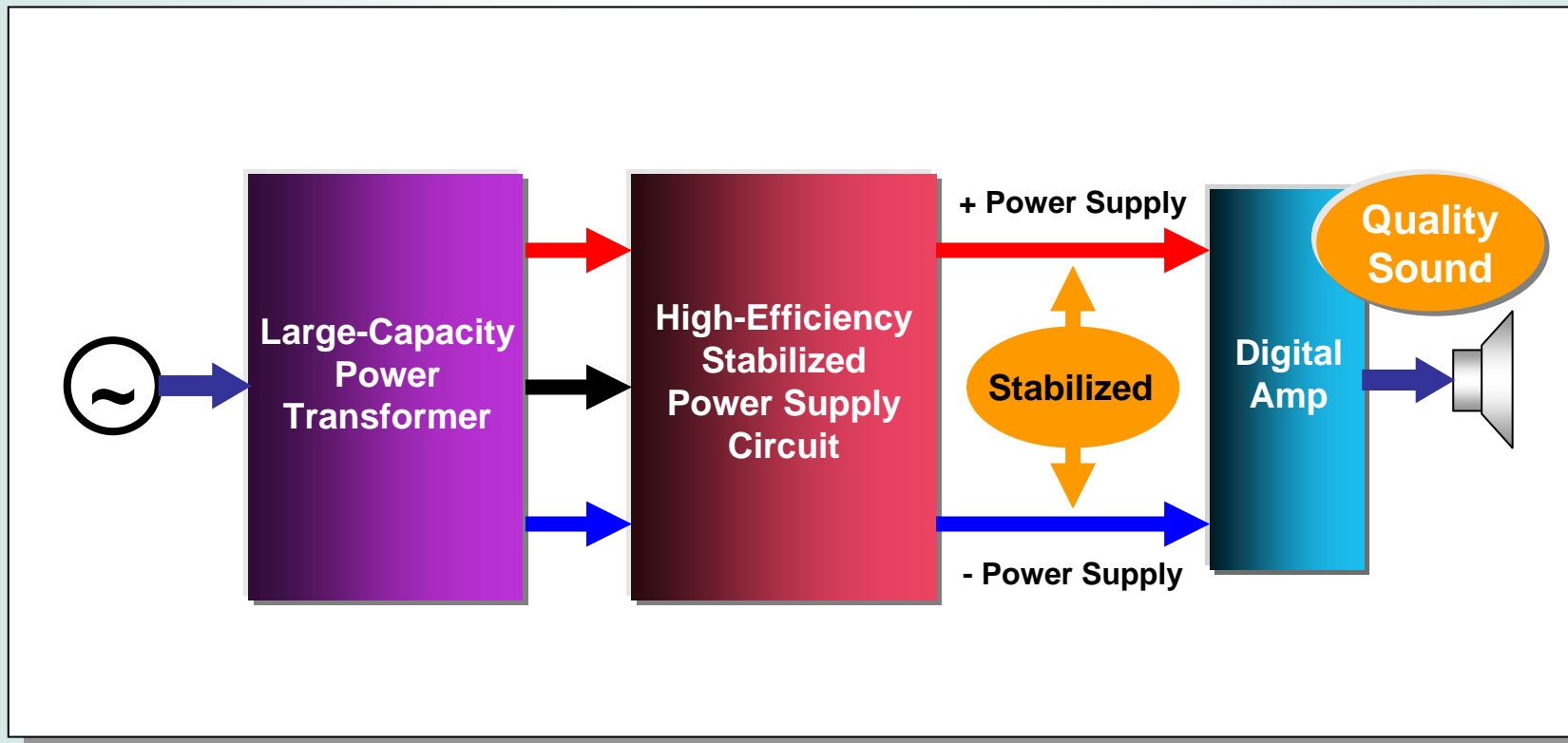



One-Chip Solution with JCV8015

RX-D702

RX-D402

*Also applies to RX-D401

The Hybrid Feedback Digital Amplifier Ver. III features use of a new IC dubbed “JCV8015”. This superior device, developed by JVC, contains all the circuits necessary for digital signal processing, including dual audio input circuits, the Hybrid Feedback Signal Processing Circuit, and PWM modulators. In addition to allowing a drastic reduction in parts and a smaller “footprint”, JCV8015 comes with the following features:

- Superior operational amp for low distortion and low noise
- High-precision PWM modulator -- featuring synchronization by external clock
- Built-in $\pm 2.5V$ regulator separated from analog GND

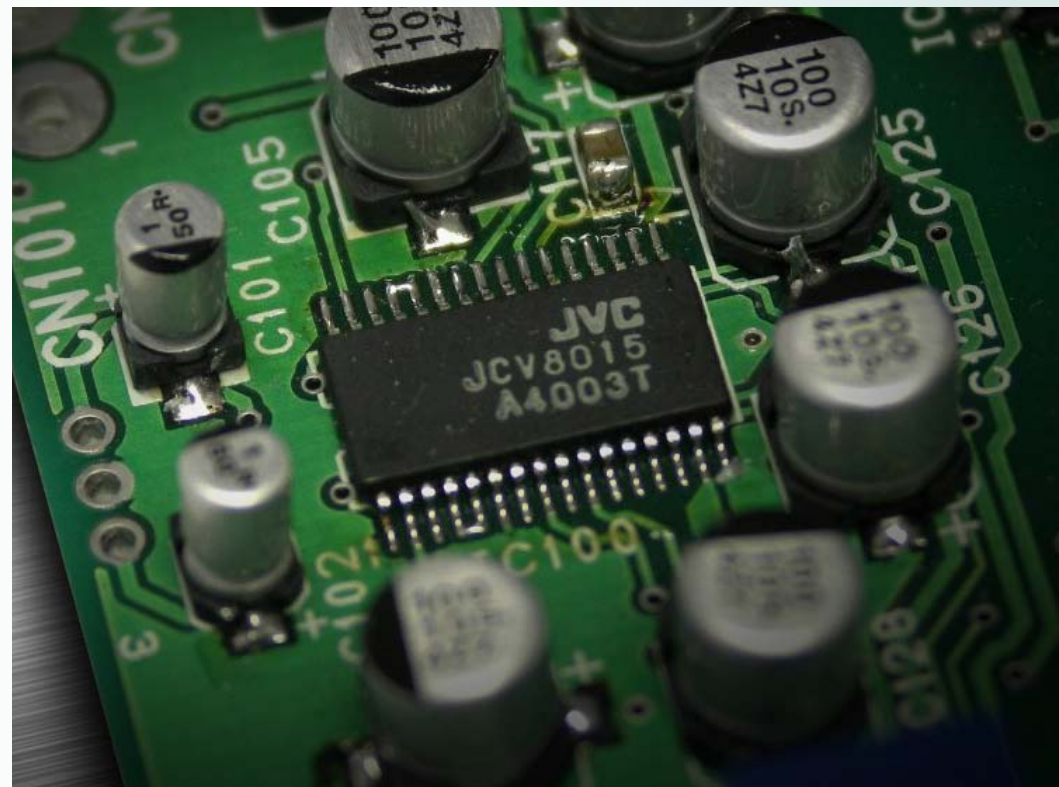



JCV8015 Benefits (1) -- Operational Amp

RX-D702

RX-D402

*Also applies to RX-D401

Superior Operational Amp for Low Distortion and Low Noise

High Slew Rate

The operational amp comes with a higher slew rate -- two times higher than the previous types of devices -- to eliminate instantaneous "cross-modulation distortion".

Interference-Free Layout

The operational amp features a symmetrical layout of parts and devices, which are completely separated for left and right channels. This prevents signal interference between the two channels (see the figure at right).

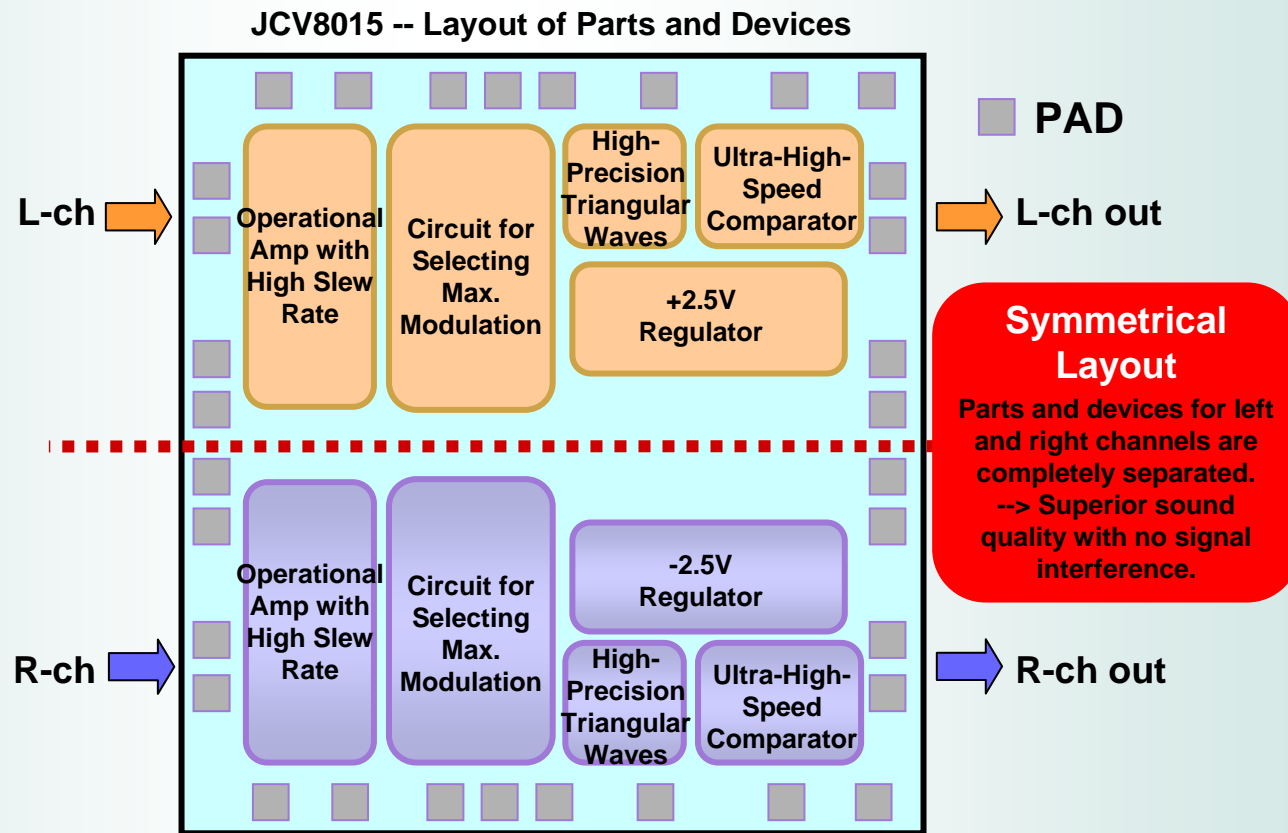



RX-D702

RX-D402

*Also applies to RX-D401

High-Precision PWM Modulator

High-Precision Triangular Waves

Distortion or irregular angles of the triangular waves lower the precision of PWM signals, which results in lower sound quality. The JCV8015 uses high-precision triangular waves to prevent the problem.

Ultra-High-Speed Comparator

Comparison of audio signals with the triangular waves is done by “comparator”. The JVC amp features an ultra-high-speed comparator. This prevents the possible delay of PWM signals with respect to audio signals, which causes distortion.

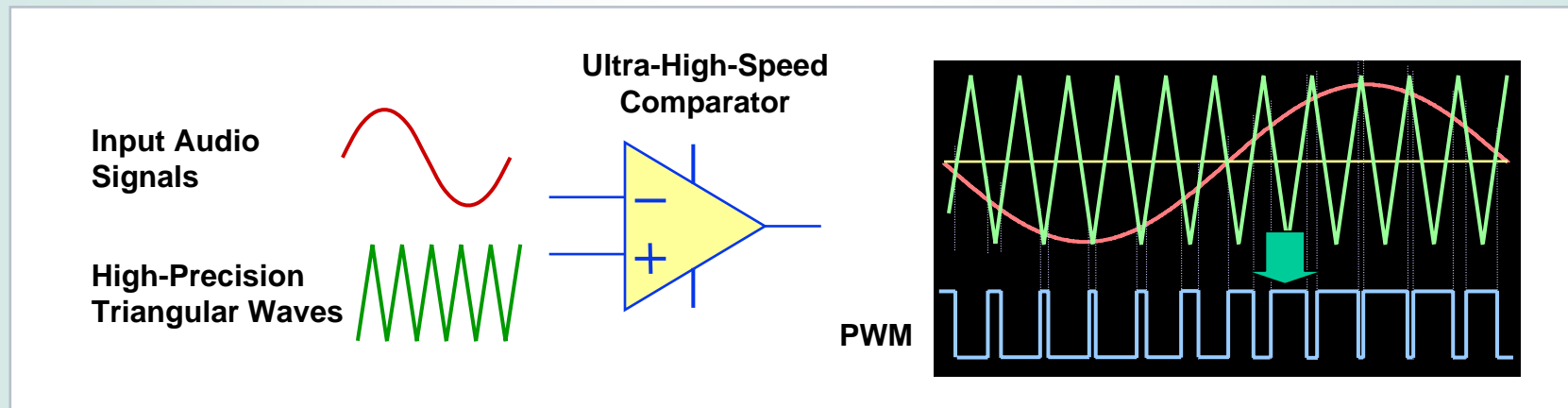

Synchronization by an External Clock

Slight gap of frequencies among channels causes specific noise. To prevent this, the JVC amplifier uses an external clock, which synchronizes the operations of all channels. Noise is also generated when the unit receives AM signals whose frequency overlaps that of audio signals. The external clock detects this and automatically modifies the audio signal frequency of all the channels simultaneously, thus preventing the noise generation.



JCV8015 Benefits (3) -- $\pm 2.5V$ Regulator

RX-D702

RX-D402

*Also applies to RX-D401

Use of the built-in $\pm 2.5V$ regulator prevents digital noise interference to analog GND.

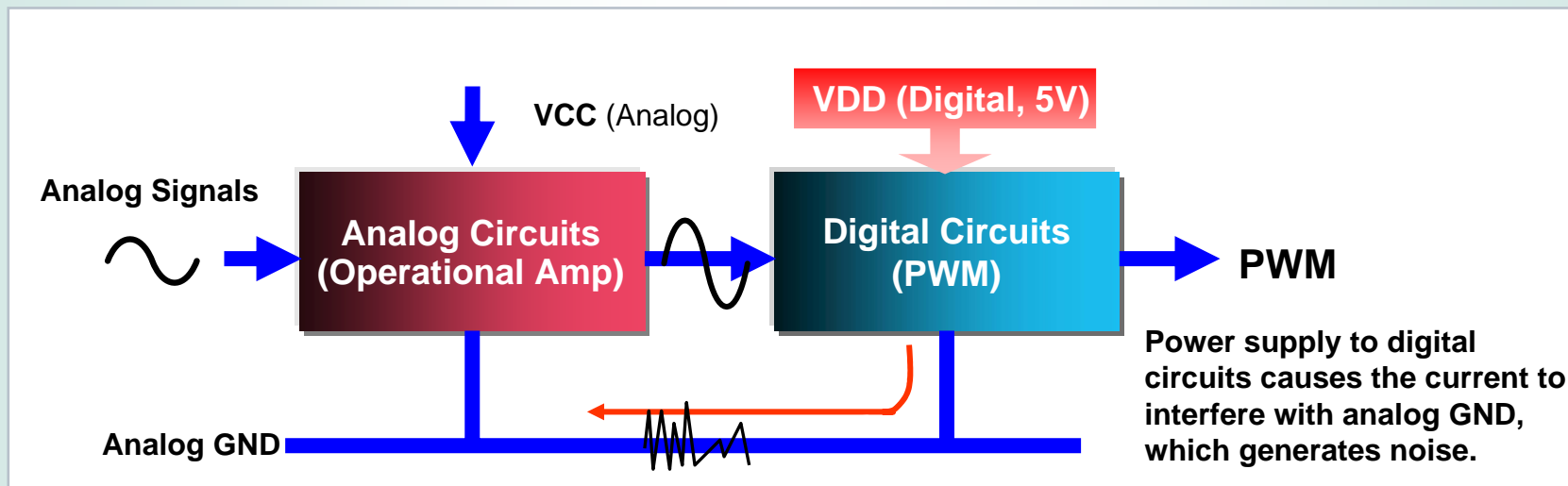
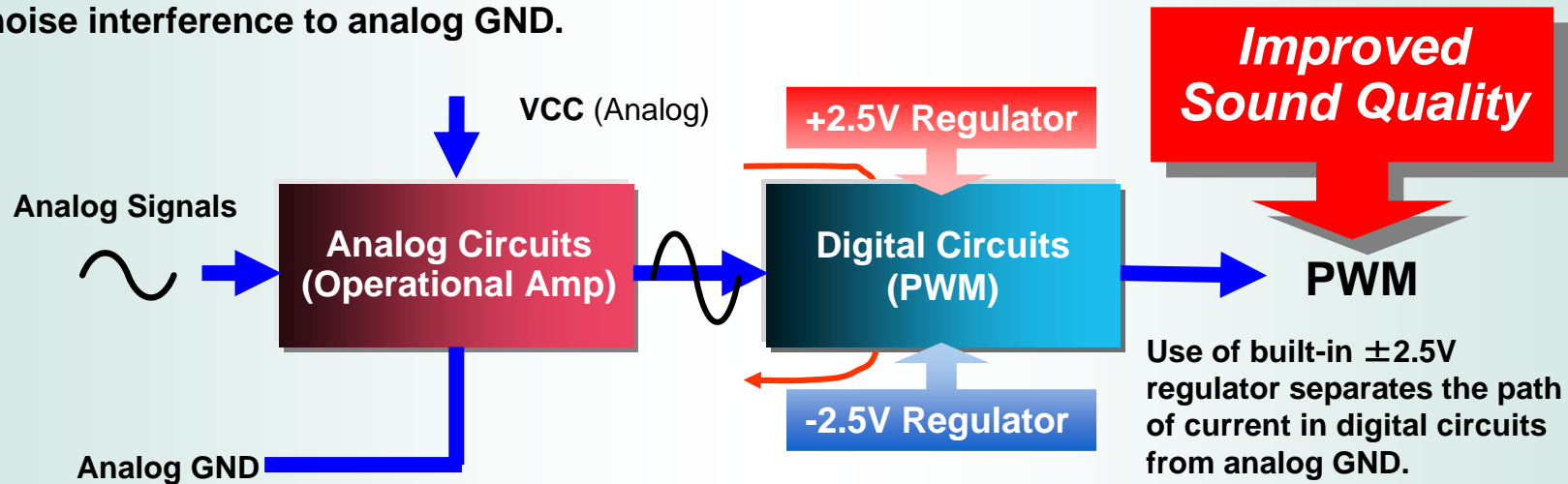



Quality Parts for Superior Sound Reproduction

The superior technologies applied for the digital amp combine to lower the total harmonic distortion by a specific ratio (see the following pages for details). This means when the distortion of input signals are lower, that of output signals are lower than when input signals have higher distortion. This is why JVC engineers applied a wide range of quality parts for the A/V receivers. These devices ensure even better sound quality by sending low-distortion signals to the Hybrid Feedback Digital Amplifier Ver. III.



2SK3770-01MR

Power MOSFET used for the 150W digital amplifier of the RX-D702.

RX-D702



IRFB4212

Power MOSFET used for the 110W digital amplifier of the RX-D402/D401.

RX-D402

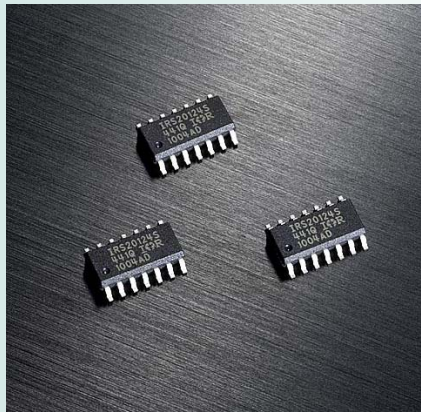

IRS20124

High-performance Driver IC incorporated in the digital amplifiers of all the units.

RX-D702 RX-D402



ETQA15

All the units feature **high-quality coils** incorporated in the output low-pass filter, which help deliver superior sound.

RX-D702 RX-D402



Comparison of Speaker Driveability

RX-D702

RX-D402

*Also applies to RX-D401

Usually, speaker impedance fluctuates according to the frequencies of audio signals.

This “frequency response” of the speaker in turn fluctuates the levels of audio signals. How effectively an amplifier can control these fluctuations is called “speaker driveability”.

The feedback processes of the Hybrid Feedback Digital Amplifier significantly improve the speaker driveability, retaining the same output level across the frequencies.

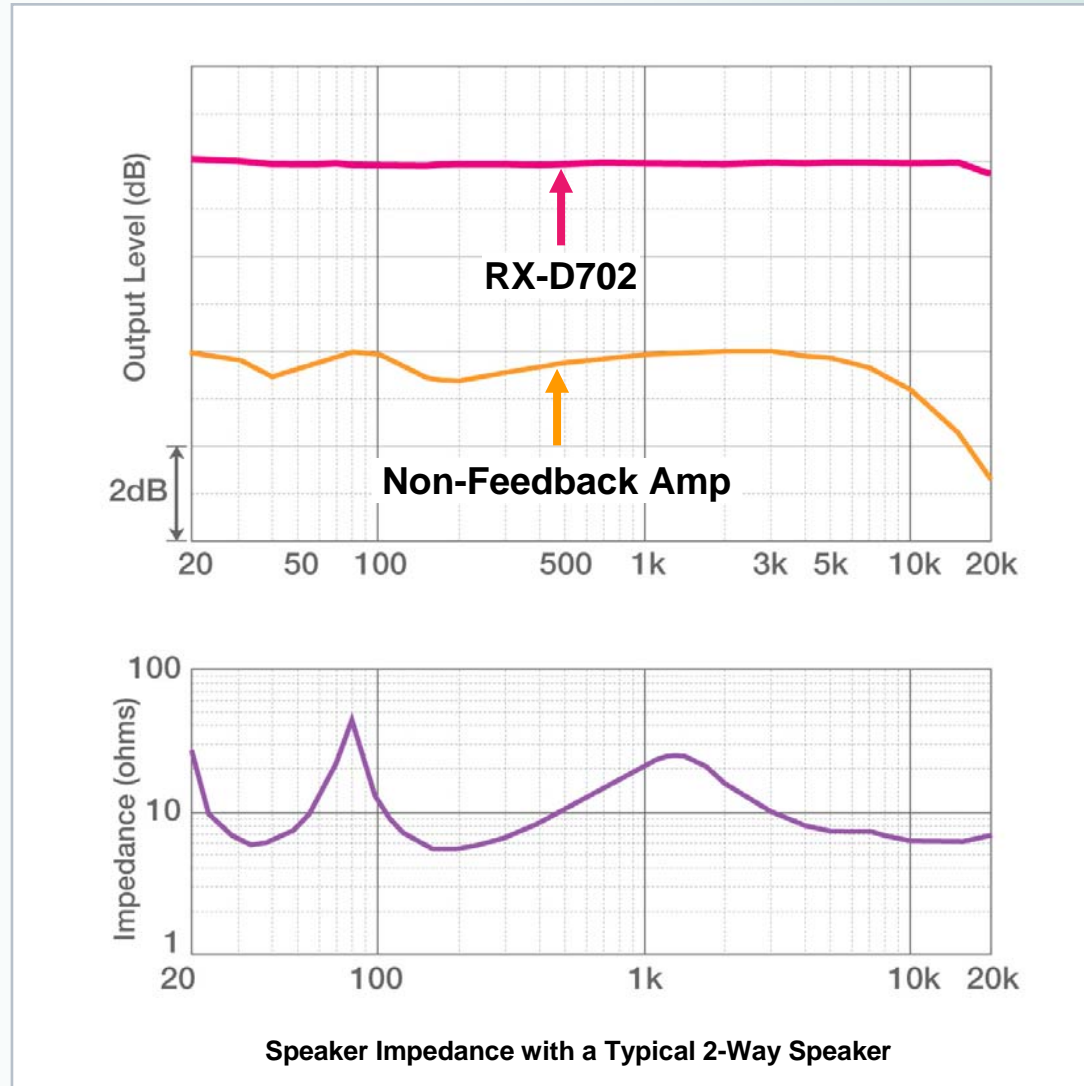



T.H.D. Comparison of Digital Amplifiers

RX-D702

RX-D402

*Also applies to RX-D401

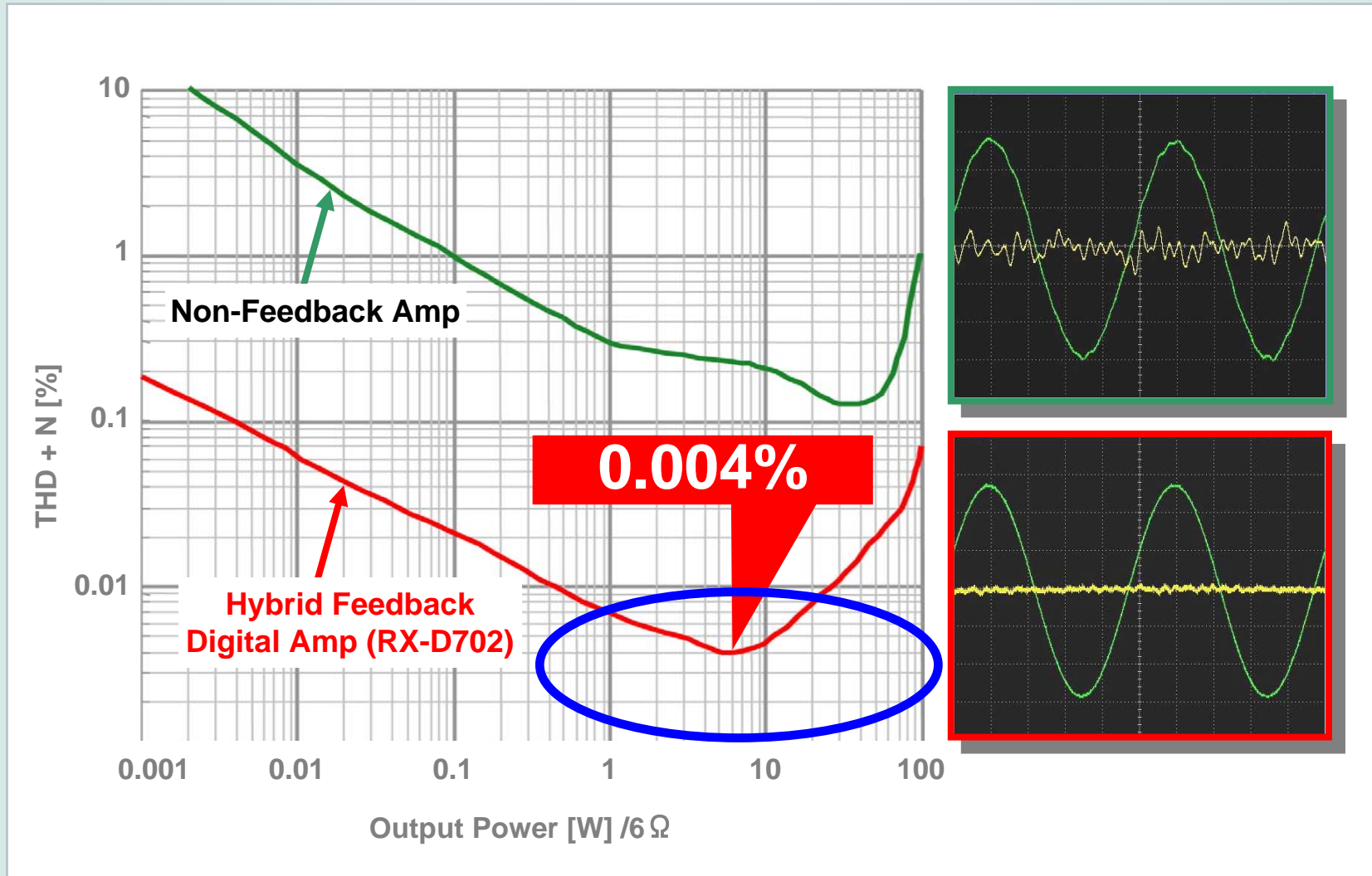



OSD Superimposed on Screen	58
RX-D702B Audio/Video Control Receiver	59
RX-D402B Audio/Video Control Receiver	60
Multi-Brand A/V-STB (CATV/DBS) Glow Remote Control	61
Rear Panel	62



OSD Superimposed on Screen

RX-D702

The RX-D702 displays a wide range of information -- including the Smart Surround Setup processes -- superimposed on your monitor screen to ensure easy recognition and control.

OSD for Smart Surround Setup

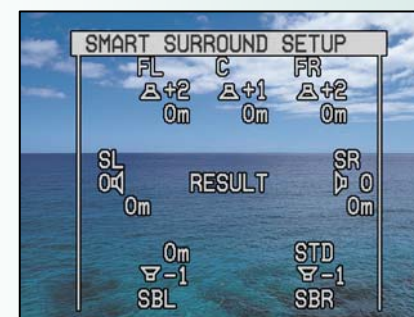
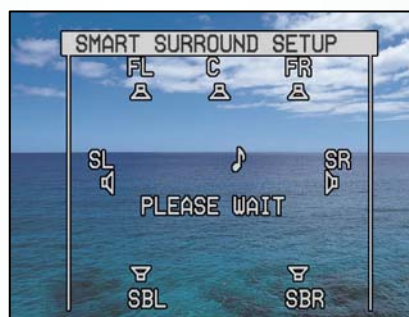
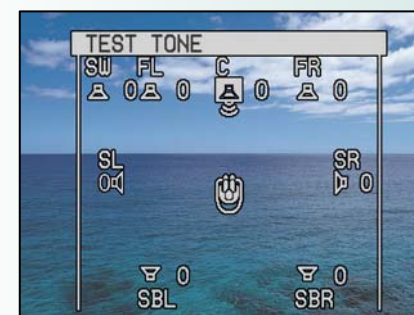
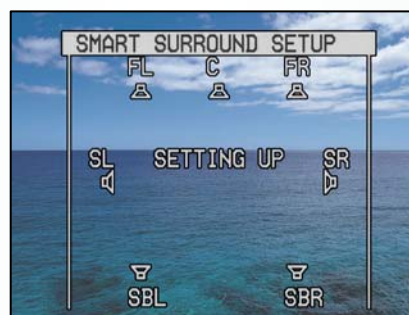

Setting Menu Screen

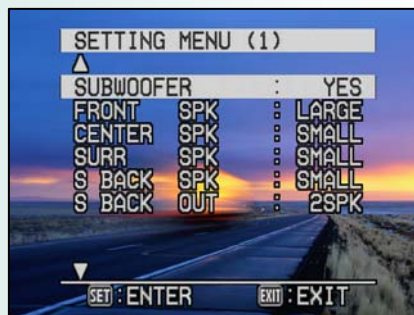

Digital EQ and Bass Boost Setup



Speaker Setup





RX-D702B Audio/Video Control Receiver



7-Channel Receiver Featuring HDMI, New Digital Amplifier, and Wireless PC Connectivity

Basic Features

- Stereo: 150 watts per channel, 6 ohms, from 20Hz to 20kHz, with 0.8% THD
- Surround: (Front) 150 watts per channel, 6 ohms at 1kHz, with 0.8% THD; (Center) 150 watts, 6 ohms at 1kHz, with 0.8% THD; (Surround) 150 watts per channel, 6 ohms at 1kHz, with 0.8% THD; (Surround Back) 150 watts per channel, 6 ohms at 1kHz, with 0.8% THD
- Dolby Digital EX/Dolby Digital/Dolby Pro Logic II/Dolby Pro Logic II
- DTS/DTS-ES/DTS NEO:6/DTS 96/24
- DVD Multi-Channel Audio Compatible

Product Highlights

- Hybrid Feedback Digital Amplifier Ver. III
- HDMI – for single-cable, all-digital transmission of audio and video signals
- Wireless Connection with PC -- enjoy playback of music files from PC
- CC Converter (2 Modes, Front Channels) -- offers two modes for improving the sound quality of compressed audio and non-compressed sources, respectively
- USB Input for receiving audio signals from PC
- SIRIUS Input and SIRIUS Control on Remote
- On-Screen Display
- Center-Channel Alignment
- Virtual Surround Back for creating even wider sound field without a surround back speaker
- 3D-PHONIC
- DAP for Multi-Channel Digital Sources: THEATER 1/THEATER 2/HALL 1/ HALL 2/ DANCE CLUB/LIVE CLUB/PAVILION
- DAP for 2-Channel Sources: MONO FILM/THEATER 1/THEATER 2/HALL 1/ HALL 2/DANCE CLUB/LIVE CLUB/ PAVILION/ALL CH STEREO
- 3D Headphone
- 192kHz/24-bit P.E.M. D.D. Converter (Front/Center/Surround Channels)
- Video Signal Up-Conversion (to HDMI) for single-cable output of high-quality video from any input terminals
- Smart Surround Setup (Ver. 3.0) -- easy handclap setting up of the acoustic environment
- One-Touch Operation
- DSP Digital Equalizer
- AV COMPU LINK
- Multi-Brand A/V-STB (CATV/DBS) Glow Remote Control



RX-D402B Audio/Video Control Receiver



7-Channel Receiver with HDMI, PC Connection via USB and New Digital Amplifier

Basic Features

- Stereo: 110 watts per channel, 6 ohms, from 20Hz to 20kHz, with 0.8% THD
- Surround: (Front) 110 watts per channel, 6 ohms at 1kHz, with 0.8% THD; (Center) 110 watts, 6 ohms at 1kHz, with 0.8% THD; (Surround) 110 watts per channel, 6 ohms at 1kHz, with 0.8% THD; (Surround Back) 110 watts per channel, 6 ohms at 1kHz, with 0.8% THD
- Dolby Digital EX/Dolby Digital/Dolby Pro Logic IIx/Dolby Pro Logic II
- DTS/DTS-ES/DTS NEO:6/DTS 96/24
- DVD Multi-Channel Audio Compatible

Product Highlights

- Hybrid Feedback Digital Amplifier Ver. III
- HDMI -- for single-cable, all-digital transmission of audio and video signals
- Video Up-Conversion (to HDMI) for single-cable output of high-quality video from any input terminals
- USB Input for receiving audio signals from PC
- Center-Channel Alignment
- Virtual Surround Back for creating even wider sound field without a surround back speaker
- 3D-PHONIC
- DAP for Multi-Channel Digital Sources: THEATER 1/THEATER 2/HALL 1/HALL 2/ DANCE CLUB/LIVE CLUB/PAVILION
- DAP for 2-Channel Sources: MONO FILM/THEATER 1/THEATER 2/HALL 1/ HALL 2/DANCE CLUB/LIVE CLUB/ PAVILION/ALL CH STEREO
- 3D Headphone
- 192kHz/24-bit P.E.M. D.D. Converter (Front/Center/Surround Channels)
- Quick Speaker Setup
- One-Touch Operation
- DSP Digital Equalizer
- AV COMPU LINK
- Multi-Brand A/V-STB (CATV/DBS) Glow Remote Control



Multi-Brand A/V-STB (CATV/DBS) Glow Remote Control

For RX-D702B



For RX-D402B/RX-D401S





Rear Panel

RX-D702B

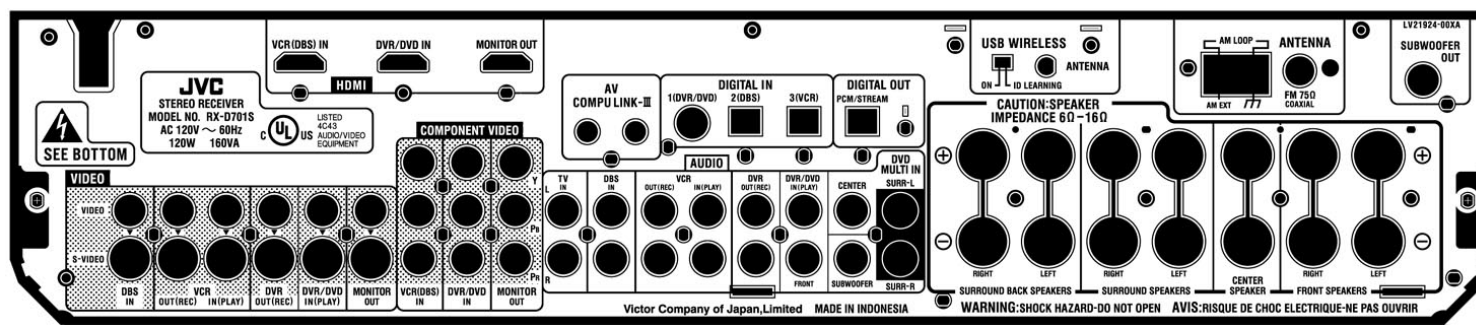

RX-D402B/RX-D401S

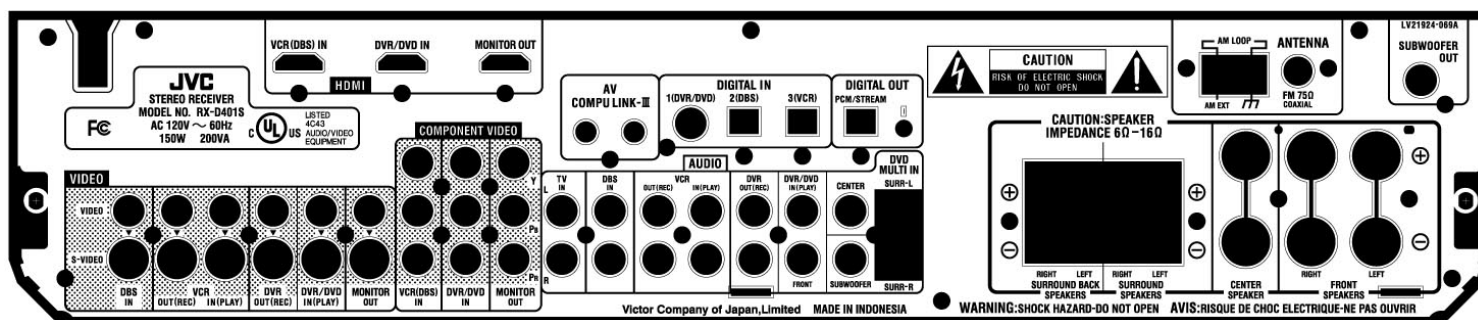

JVC[®]

The Perfect Experience / —
/

Free Manuals Download Website

<http://myh66.com>

<http://usermanuals.us>

<http://www.somanuals.com>

<http://www.4manuals.cc>

<http://www.manual-lib.com>

<http://www.404manual.com>

<http://www.luxmanual.com>

<http://aubethermostatmanual.com>

Golf course search by state

<http://golfingnear.com>

Email search by domain

<http://emailbydomain.com>

Auto manuals search

<http://auto.somanuals.com>

TV manuals search

<http://tv.somanuals.com>