

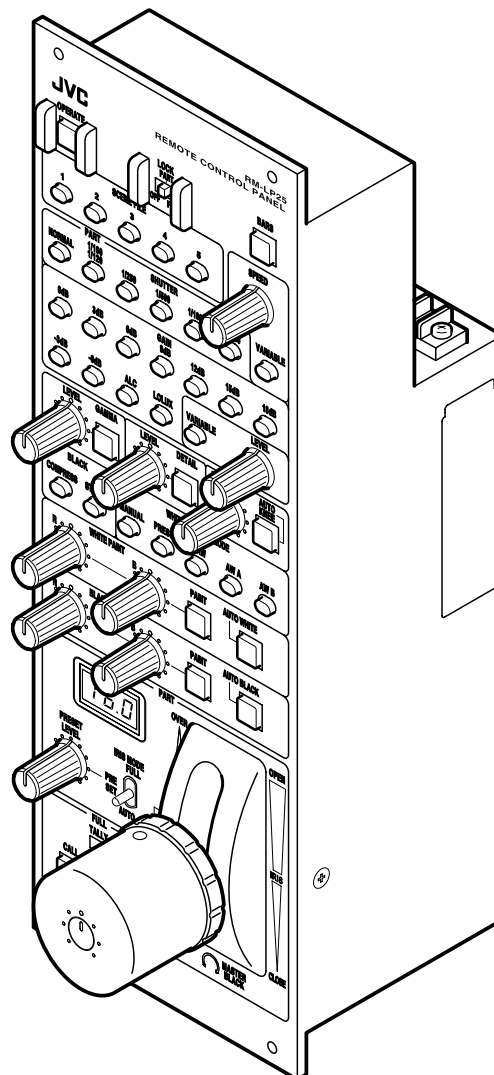

REMOTE CONTROL PANEL

RM-LP25U

INSTRUCTIONS



Thank you for purchasing this JVC product.
Before beginning to operate this unit, please read
the instructions
carefully to ensure the best possible performance.

For Customer Use:

Enter below the Serial No. which is located on the
body.

Retain this information for future reference.

Model No. _____

Serial No. _____

LST0594-001A

Getting Started

FOR USA

These are general **IMPORTANT SAFEGUARDS** and certain items may not apply to all appliances.

IMPORTANT SAFEGUARDS

1. Read all of these instructions.
2. Save these instructions for later use.
3. All warnings on the product and in the operating instructions should be adhered to.
4. Unplug this appliance system from the wall outlet before cleaning. Do not use liquid cleaners or aerosol cleaners. Use a damp cloth for cleaning.
5. Do not use attachments not recommended by the appliance manufacturer as they may cause hazards.
6. Do not use this appliance near water - for example, near a bathtub, washbowl, kitchen sink, or laundry tub, in a wet basement, or near a swimming pool, etc.
7. Do not place this appliance on an unstable cart, stand, or table. The appliance may fall, causing serious injury to a child or adult, and serious damage to the appliance.
Use only with a cart or stand recommended by the manufacturer, or sold with the appliance. Wall or shelf mounting should follow the manufacturer's instructions, and should use a mounting kit approved by the manufacturer. An appliance and cart combination should be moved with care.
Quick stops, excessive force, and uneven surfaces may cause the appliance and cart combination to overturn.
8. Slots and openings in the cabinet and the back or bottom are provided for ventilation, and to insure reliable operation of the appliance and to protect it from overheating, these openings must not be blocked or covered. The openings should never be blocked by placing the appliance on a bed, sofa, rug, or other similar surface.
This appliance should never be placed near or over a radiator or heat register.
This appliance should not be placed in a built-in installation such as a bookcase unless proper ventilation is provided.
9. This appliance should be operated only from the type of power source indicated on the marking label. If you are not sure of the type of power supplied to your home, consult your dealer or local power company. For appliance designed to operate from battery power, refer to the operating instructions.
10. For added protection for this product during a lightning storm, or when it is left unattended and unused for long periods of time, unplug it from the wall outlet and disconnect the antenna or cable system. This will prevent damage to the product due to lightning and power-line surges.
11. Do not allow anything to rest on the power cord. Do not locate this appliance where the cord will be abused by persons walking on it.
12. Follow all warnings and instructions marked on the appliance.
13. Do not overload wall outlets and extension cords as this can result in fire or electric shock.
14. Never push objects of any kind into this appliance through cabinet slots as they may touch dangerous voltage points or short out parts that could result in a fire or electric shock. Never spill liquid of any kind on the appliance.
15. Do not attempt to service this appliance yourself as opening or removing covers may expose you to dangerous voltage or other hazards. Refer all servicing to qualified service personnel.
16. Unplug this appliance from the wall outlet and refer servicing to qualified service personnel under the following conditions:
 - a. When the power cord or plug is damaged or frayed.
 - b. If liquid has been spilled into the appliance.
 - c. If the appliance has been exposed to rain or water.
 - d. If the appliance does not operate normally by following the operating instructions. Adjust only those controls that are covered by the operating instructions as improper adjustment of other controls may result in damage and will often require extensive work by a qualified technician to restore the appliance to normal operation.
 - e. If the appliance has been dropped or the cabinet has been damaged.
 - f. When the appliance exhibits a distinct change in performance - this indicates a need for service.
17. When replacement parts are required, be sure the service technician has used replacement parts specified by the manufacturer that have the same characteristics as the original part. Unauthorized substitutions may result in fire, electric shock, or other hazards.
18. Upon completion of any service or repairs to this appliance, ask the service technician to perform routine safety checks to determine that the appliance is in safe operating condition.

PORTABLE CART WARNING
(symbol provided by RETAC)



S3125A

Safety Precautions

FOR USA AND CANADA



CAUTION

RISK OF ELECTRIC SHOCK
DO NOT OPEN



CAUTION: TO REDUCE THE RISK OF ELECTRIC SHOCK. DO NOT REMOVE COVER (OR BACK). NO USER-SERVICEABLE PARTS INSIDE. REFER SERVICING TO QUALIFIED SERVICE PERSONNEL.



The lightning flash with arrowhead symbol, within an equilateral triangle is intended to alert the user to the presence of uninsulated "dangerous voltage" within the product's enclosure that may be of sufficient magnitude to constitute a risk of electric shock to persons.



The exclamation point within an equilateral triangle is intended to alert the user to the presence of important operating and maintenance (servicing) instructions in the literature accompanying the appliance.

Information for USA

INFORMATION:

This equipment has been tested and found to comply with the limits for a Class A digital device, pursuant to Part 15 of the FCC Rules.

These limits are designed to provide reasonable protection against harmful interference when the equipment is operated in a commercial environment.

This equipment generates, uses, and can radiate radio frequency energy and, if not installed and used in accordance with the instruction manual, may cause harmful interference to radio communications.

Operation of this equipment in a residential area is likely to cause harmful interference in which case the user will be required to correct the interference at his own expense.

CAUTION:

CHANGES OR MODIFICATIONS NOT APPROVED BY JVC COULD VOID USER'S AUTHORITY TO OPERATE THE EQUIPMENT.

NOTE:

The rating plate (serial number plate) is on this unit.

WARNING:

TO REDUCE THE RISK OF FIRE OR ELECTRIC SHOCK, DO NOT EXPOSE THIS APPLIANCE TO RAIN OR MOISTURE.

THIS DEVICE COMPLIES WITH PART 15 OF THE FCC RULES. OPERATION IS SUBJECT TO THE FOLLOWING TWO CONDITIONS: (1) THIS DEVICE MAY NOT CAUSE HARMFUL INTERFERENCE, AND (2) THIS DEVICE MUST ACCEPT ANY INTERFERENCE RECEIVED, INCLUDING INTERFERENCE THAT MAY CAUSE UNDESIRABLE OPERATION.

This unit should be used with 9 V DC only.

INFORMATION (FOR CANADA) RENSEIGNEMENT (POUR CANADA)

This Class A digital apparatus complies with Canadian ICES-003.

Cet appareil numérique de la Classe A est conforme à la norme NMB-003 du Canada.

WARNING:
TO REDUCE THE RISK OF FIRE OR ELECTRIC SHOCK, DO NOT EXPOSE THIS APPLIANCE TO RAIN OR MOISTURE.

This unit should be used with 9V DC only.

CAUTION:

To prevent electric shocks and fire hazards, do NOT use any other power source.

AVERTISSEMENT:
POUR EVITER LES RISQUES D'INCENDIE OU D'ELECTROCUTION, NE PAS EXPOSER L'APPAREIL A L'HUMIDITE OU A LA PLUIE.

Ce magnéscope ne doit être utilisé que sur du courant direct en 9V.

ATTENTION:

Afin d'éviter tout risque d'incendie ou d'électrocution, ne pas utiliser d'autres sources d'alimentation électrique.

NOTE:

The rating plate (serial number plate) is on the side of the unit.

REMARQUE:

La plaque signalétique (plaque du numéro de série) se trouve sur la paroi latérale de l'appareil.

CAUTION:

To prevent electric shock, do not open the cabinet. No user serviceable parts inside. Refer servicing to qualified service personnel.

Due to design modifications, data given in this instruction book are subject to possible change without prior notice.

The apparatus shall not be exposed to dripping or splashing and that no objects filled with liquids, such as vases, shall be placed close to the apparatus.

Safety Precautions (continued)

FOR EUROPE

This equipment is in conformity with the provisions and protection requirements of the corresponding European Directives. This equipment is designed for professional video appliances and can be used in the following environments:

- Controlled EMC environment (for example, purpose-built broadcasting or recording studio), and rural outdoors environments.

In order to keep the best performance and furthermore for electromagnetic compatibility we recommend to use cables not exceeding the following lengths:

	Cable	Maximum Cable Length
REMOTE CABLE	Shielded Cable	5 m
PREVIEW	Shielded Cable	3 m
TALLY(PVM)	Shielded Cable	3 m
TALLY(PGM)	Shielded Cable	3 m
GND	Shielded Cable	3 m

Caution:

Where there are strong electromagnetic waves or magnetism, for example near a radio or TV transmitter, transformer, motor, etc., the picture and the sound may be disturbed. In such case, please keep the apparatus away from the sources of the disturbance.

Dear Customer,

This apparatus is in conformance with the valid European directives and standards regarding electromagnetic compatibility and electrical safety.

European representative of Victor Company of Japan Limited is:
 JVC Technology Centre Europe GmbH
 P.O.Box 10 05 52
 61145 Friedberg
 Germany

Information for Users on Disposal of Old Equipment [European Union]

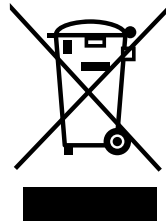

Attention:

This symbol is only valid in the European Union.

This symbol indicates that the electrical and electronic equipment should not be disposed as general household waste at its end-of-life. Instead, the product should be handed over to the applicable collection point for the recycling of electrical and electronic equipment for proper treatment, recovery and recycling in accordance with your national legislation.

By disposing of this product correctly, you will help to conserve natural resources and will help prevent potential negative effects on the environment and human health which could otherwise be caused by inappropriate waste handling of this product. For more information about collection point and recycling of this product, please contact your local municipal office, your household waste disposal service or the shop where you purchased the product. Penalties may be applicable for incorrect disposal of this waste, in accordance with national legislation.

(Business users)

If you wish to dispose of this product, please visit our web page www.jvceurope.com to obtain information about the take-back of the product.

[Other Countries outside the European Union]

If you wish to dispose of this product, please do so in accordance with applicable national legislation or other rules in your country for the treatment of old electrical and electronic equipment.

FOR USE IN CHINA ONLY

《电子信息产品污染控制管理办法》规定的表示内容

关于环保使用期限



环保使用期限

- 此图标表示了中国《电子信息产品污染控制管理办法》规定的环保使用期限。只要用户在使用本产品时遵守注意事项中的各项规定，从制造日期开始到此图标标出的期限为止（环保使用期限）既不会污染环境也不会产生对人体有害的物质。

关于产品中的有毒、有害物质

零件名称	有毒或有害物质、元素					
	铅 (Pb)	水银 (Hg)	镉 (Cd)	六价铬 (Cr6+)	多溴联苯 (PBB)	多溴二苯醚 (PBDE)
线路板组件	×	○	○	○	○	○
机箱	×	○	○	○	○	○
其他附件	×	○	○	○	○	○

○：此零件中的每个均匀材料所含有毒、有害物质的量在SJ/T 11363-2006标准规定的范围之内。
 ×：此零件中至少有一种均匀材料含有毒、有害物质的量超过了SJ/T 11363-2006标准的规定。

Features

This product is a remote control panel for controlling HD CAMERA RECORDER(GY-HD250/GY-HD251/GY-HD200/GY-HD201).

Scene File Feature

You can assign different settings to each of the five Scene File buttons and save them accordingly.

This is useful at job sites where speed is required, as you can recall the settings according to the shooting conditions by pressing the relevant button.

Self-illuminating Indicator

Buttons that are enabled are indicated in green, allowing you to identify the usable features easily.

A button that is selected lights up in orange, allowing you to identify the current camera settings easily.

In addition, the buttons and switches are also appropriately arranged according to their frequency of use.

Iris F-value Display

The iris F-value of the camera is indicated on the remote control.

This enables you to perform accurate adjustment by grasping the iris condition at real-time.

How to read this manual

■ Definition of Symbols

Note : Precautions that need to be taken during operation.

Memo : Details for reference, such as features and restrictions during use.

 : Page or item to refer to.

■ Descriptions in this manual

- The copyright of this manual belongs to Victor Company of Japan, Limited. Reproduction or duplication of a part or the whole of this manual without permission is prohibited.
- Product names of other companies contained in this manual are the trademark or registered trademark of the respective companies. Symbols such as TM, [®], and [©] are omitted in this manual.
- Designs, specifications, and other details contained in this manual may be modified for improvement without prior notice.

Precautions During Use

Location of Storage and Use

- Do not place this product at the following locations.
 - Doing so may cause the product to malfunction or break down.
 - Hot or cold places beyond the allowable operating temperature range of -5 °C to +40 °C.
 - Humid places beyond the allowable humidity range of 30 % RH to 80 % RH (non-condensing).
 - Places in the vicinity of a strong magnetic field, such as near transformers or motors.
 - Near equipment that emit radio waves, such as transceivers or mobile phones.
 - Places that are subject to dust or sand.
 - Places that are subject to strong vibrations.
 - Places that are susceptible to condensation, such as near windows.
 - Places that are subject to vapor or oil, such as kitchens.
 - Places that emit radioactive rays or X-rays, and corrosive gases.
- Noise may occur in the images or their colors may change when this product and the cable that is used to connect it are used at a place that is subject to strong radio or magnetic waves (e.g., near radios, TVs, transformers, or monitors).

Handling Precautions

- Insufficient ventilation may result in malfunction of this product. Make sure that objects placed around this product do not obstruct its ventilation.
- Do not place containers with water (e.g. vases, flower pots, cups, toiletry products, or chemicals) on top of this product. Moisture that enters this product may cause fire or electric shock.

Moving the Product

- Remove connection cables before moving this product
When moving this product, do so after turning off the power of the connected camera, and make sure that you unplug the cable from the camera. Failure to do so may damage the cable or cause fire or electric shock.

Maintenance

- Turn off the power of the connected camera before performing maintenance of this product.
- Use a soft cloth to wipe the product. Do not wipe using thinner or benzene, as doing so may cause the surface to melt or turn cloudy. When there is significant soiling, wipe using a cloth by dipping it in a neutral detergent that is diluted with water, followed by cleaning using a dry cloth.

Energy Conservation

- When this product is not to be used for a prolonged period of time, turn of the power of the system for safety and energy conservation purposes.

Table of Contents

Getting Started

Safety Precautions	3
Features	5
Precautions During Use	5
Table of Contents	6
Names and Functions of Parts	7
Control Panel	7
Rear/Side of Remote Control Panel	13

Operation

Exemplary System	14
Setup	14
Shutter Settings	15
Gain Settings	16
White Balance Adjustment	17
Automatic Adjustment	17
Manual Adjustment	17
Black Balance Adjustment	18
Automatic Adjustment	18
Manual Adjustment	18
Scene File	19
Storing a New Scene File	19
Loading a Scene File	20
Clearing a Scene File	20
List of Supported Features in Scene Files	21
Adjustment of Indicator's Brightness	22
Input/Output of Rear Ports	22
Tally Input Terminal	23
PREVIEW Output Terminal	23
Setting Selection DIP Switch	24
Operable Features	25
Operation of Connected Camera	26
Remote Connector Specifications	26

Others

Troubleshooting	27
Specifications	27

Names and Functions of Parts

Control Panel

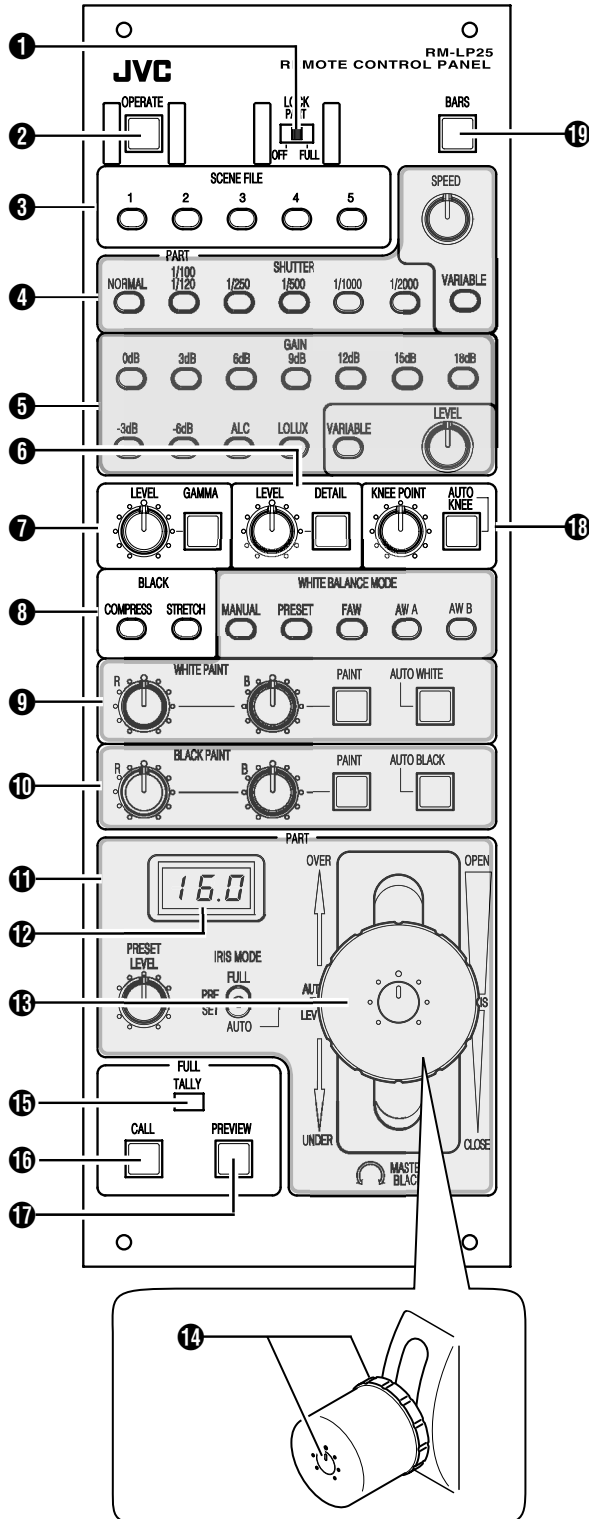

Indicator light:

For features that make use of self-illuminating buttons, features available on the connected camera are checked and displayed during communication to verify connection with the camera (initial communication).

※ However, this excludes the [OPERATE], [SCENE FILE 1 to 5], and [PREVIEW] buttons.

Orange light on : Currently selected.

Green light on : Not selected but available for selection.

Light off : Feature is not available on the camera and cannot be selected.

Memo:

- The light is turned off if a feature is available on the camera but disabled due to the settings of this product.

Memory function:

This unit has a memory function that will memorize the value of switch and knob, which have been set once. (excluding [IRIS MODE] switch ① and [IRIS/AUTO IRIS LEVEL] setting lever ⑬)

As such, when setting [OPERATE] button to ON, it will operate with previous settings even if the position of the knobs is different from the previous use. However, rotating the knobs when knob operation is enabled will cancel the memory and settings will be changed to the actual position of the knobs.

① [LOCK] Operation Lock Switch

An operation may be locked to maintain the settings. There are three different lock modes as indicated below.

[OFF] : Lock is turned off, and all features are enabled.

[PART] : Only those features in the bold frame indicated as "PART" and "FULL" on the control panel are enabled. Other features are locked with the current settings on the remote control remaining valid.

The following features are enabled.

- ④ [SHUTTER] control unit
- ⑤ [GAIN] control unit
- ⑪ [IRIS] control unit
- ⑬ [IRIS/AUTO IRIS LEVEL] setting lever
- ⑭ [MASTER BLACK] knob
- ⑯ [CALL] Button
- ⑰ [PREVIEW] Button

[FULL] : Only buttons in the bold frame indicated as "FULL" are enabled. Other features are locked with the current settings on the remote control remaining valid. The following features are enabled.

- ⑯ [CALL] Button
- ⑰ [PREVIEW] Button

Note:

- When in the [PART] or [FULL] mode, ON/OFF operation using the Operate button ② is also disabled.

Names and Functions of Parts (continued)

Control Panel (continued)

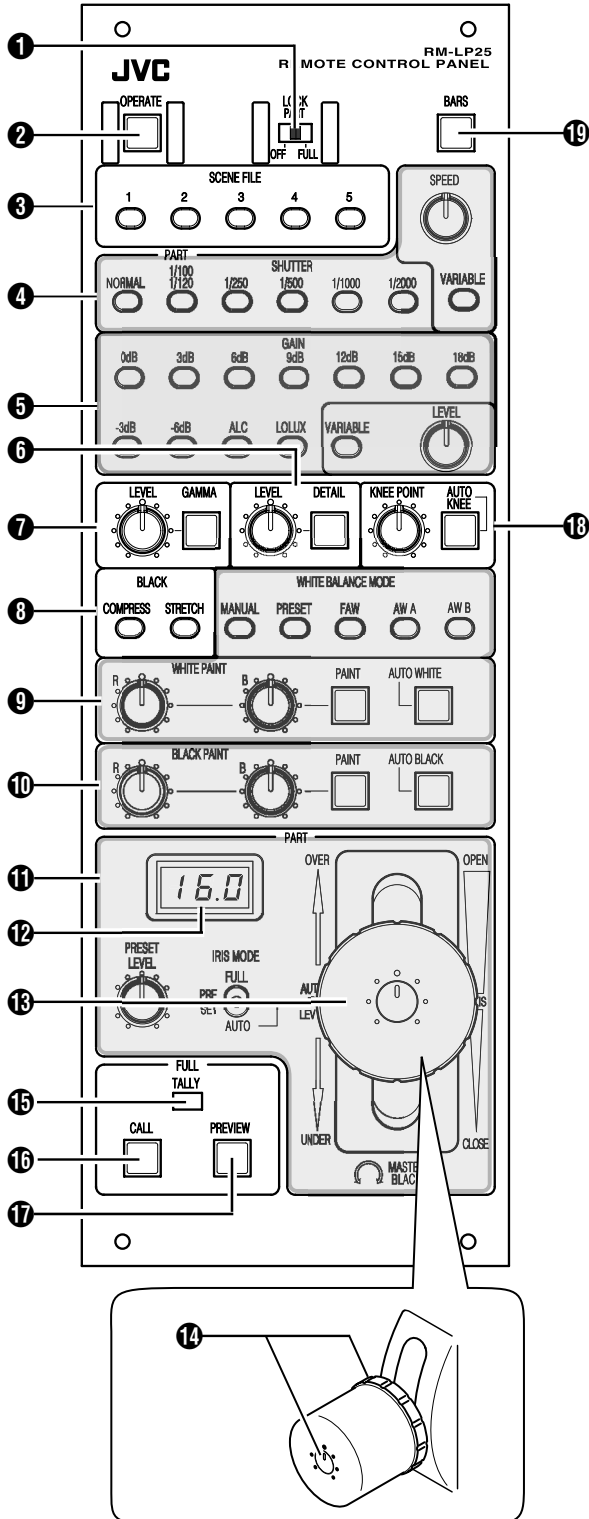

2 [OPERATE] Operate Button and Indicator Light

- ON (Orange light on) : Control of the camera using this unit is enabled.
- OFF (Light off) : Control of the camera using this unit is disabled.

3 [SCENE FILE 1 to 5] Scene File Button and Indicator Light (19 page)

For storing the scene file data and loading/clearing the preset scene file data.

4 [SHUTTER] Shutter Speed Control Unit (15 page)

For specifying the shutter settings.

5 [GAIN] Gain Control Unit (16 page)

For specifying the gain settings.

6 [DETAIL]/[LEVEL] Detail Control Unit

[DETAIL] Detail button and indicator light:

For turning ON/OFF the detail (contour) enhancement level control.

- ON (Orange light on) : Control of the detail level using this unit is enabled. Adjust by turning the [LEVEL] knob.
- OFF (Green light on) : Control of the detail level using this unit is disabled. The detail level is set to the camera's standard value.

[LEVEL] level adjustment knob:

For adjusting the detail level.



Note:

- The feature is not available on the camera if the light of the corresponding button is not lit. Control using this unit is disabled in this case.

7 [GAMMA]/[LEVEL] Gamma Control Unit

[GAMMA] Gamma button and indicator light:

For turning ON/OFF the gamma level control.

- ON (Orange light on) : Control of the gamma level using this unit is enabled. Adjust by turning the [LEVEL] knob.
- OFF (Green light on) : Control of the gamma level using this unit is disabled. The gamma level is set to the camera's standard value.

[LEVEL] level adjustment knob:

For adjusting the gamma level.

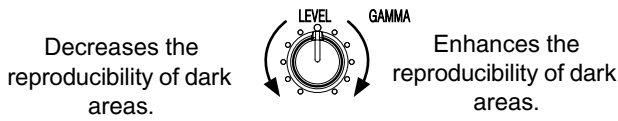

Note:

- The feature is not available on the camera if the light of the corresponding button is not lit. Control using this unit is disabled in this case.

8 [BLACK] Black Control Unit

For switching the gain value of dark areas. Switch using the video signals to be shot.

[STRETCH] Stretch button:

Enhances the contrast of dark areas in an image by stretching only the signals of the dark areas.

[COMPRESS] Compress button:

Compresses the gain value of dark areas to enhance the contrast when the image shot is bright and has little contrast.

Memo:

- When both buttons light up in green, or when one button lights up in green and the other is not lit, the setting becomes "NORMAL" (no correction).

Note:

- The feature is not available on the camera if the light of the corresponding button is not lit. Control using this unit is disabled in this case.

9 White Balance Control Unit (17 page)

For specifying the white balance settings.

● [WHITE BALANCE MODE] White Balance Mode selection button

For setting the white balance mode.

The indicator of the selected mode lights up in orange.

Setting Value	Function
MANUAL	White balance value that is set using the White Paint R/B adjustment knob is used.
PRESET	The preset white balance value (3200K) is used.
FAW	Switches to the FAW (Full-time Auto White Balance) mode, and white balance is automatically adjusted to an appropriate value.
AW A	The value stored in the camera's auto white balance memory A or B is used.
AW B	

● [AUTO WHITE] Auto White button

Pressing this button when [WHITE BALANCE MODE] is set to "AW A" or "AW B" lights up the button in orange and starts up the auto white feature.

After the adjustment is complete, the result is indicated by the indicator.

Lights up in green : Auto white is successfully completed.

Blinks in orange : Auto white is abnormally terminated.
 → Lights up in green

Note:

- When [WHITE BALANCE MODE] is set to "MANUAL", "PRESET", or "FAW", this button is not lit, and auto white does not start up.
- Setting the [BARS] button 19 to "ON" outputs a color bar image. In this case, this button is not lit, and auto white does not start up.

● [PAINT] Paint button and indicator light:

When [WHITE BALANCE MODE] is set to "AW A" or "AW B", you can specify whether fine-tuning on the value stored at the camera is to be performed.

ON : Fine-tuning enabled.
 (Orange light on) Adjust by turning the [WHITE PAINT R/B] knob.

OFF : Fine-tuning disabled.
 (Green light on) The [WHITE PAINT R/B] knob is disabled.

In addition, when [WHITE BALANCE MODE] is set to "MANUAL", the orange light turns on, and adjustment of the R/B channel's gain value using the [WHITE PAINT R/B] knob is enabled.

Note:

- After the auto white operation is complete, this button is indicated as "OFF" (green light on).
- When [WHITE BALANCE MODE] is set to "PRESET" or "FAW", this button is not lit, and the [WHITE PAINT R/B] knob control is disabled.

● [WHITE PAINT R/B] White Paint R/B adjustment knob:

The functions available differs according to the white balance mode button selected.

Setting of White Balance Mode Selection Button	Feature of White Paint Knob	Status of Paint Indicator Light
MANUAL	Knob for adjusting the R/B channel's gain value.	Lit
PRESET/FAW	Disabled.	Not lit
AW A	Knob for fine-tuning the white balance value obtained during auto white balance adjustment.	Lit
AW B		

Memo:

- You can select the corresponding white balance mode button to store settings for "MANUAL", "AW A", and "AW B" respectively.

Names and Functions of Parts (continued)

Control Panel (continued)

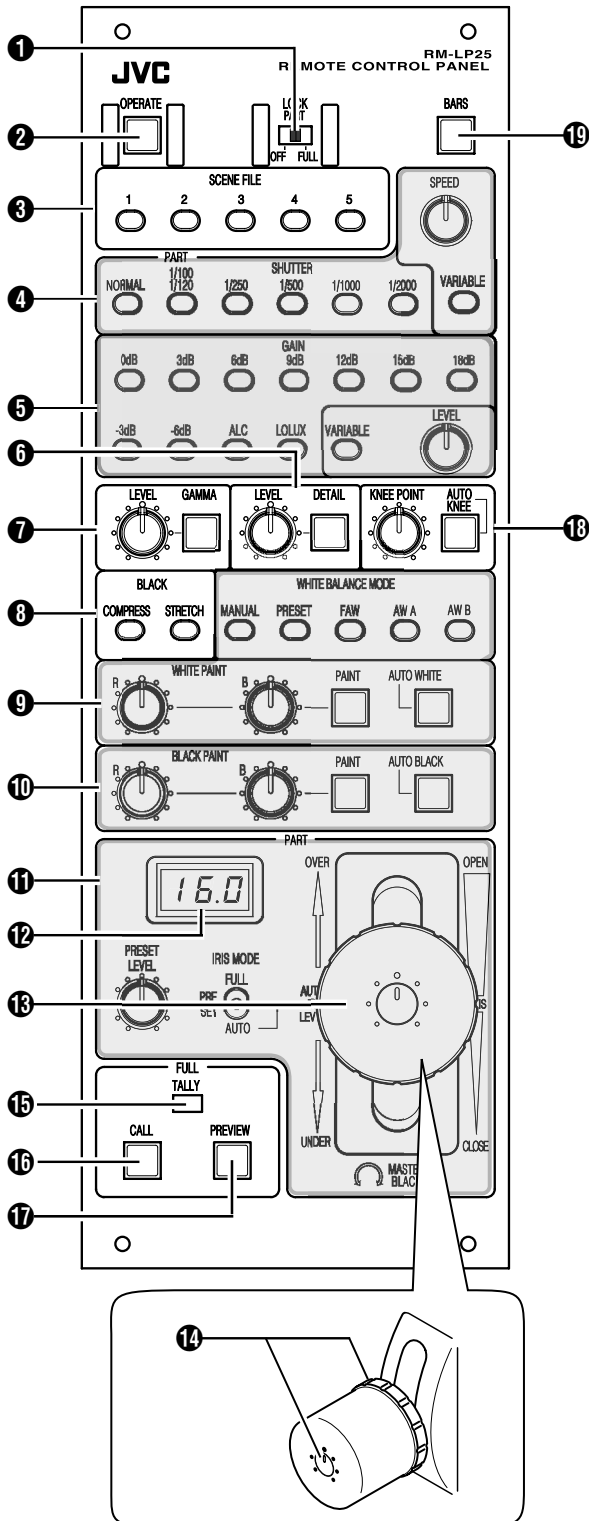

10 Black Balance Control Unit (18 page)

For specifying the black balance settings.

● [AUTO BLACK] Auto Black button:

Pressing this button when it lights up in green switches the color to orange and starts up the auto black feature. After the adjustment is complete, the result is indicated by the indicator.

- Lights up in green : Auto black is successfully completed.
- Blinks in orange : Auto black is abnormally terminated.
- Lights up in green

Note:

- The feature is not available on the camera if the light of the corresponding button is not lit. Control using this unit is disabled in this case.

● [PAINT] Paint button and indicator light:

For specifying whether fine-tuning is to be performed on the value stored at the camera.

- ON (Orange light on) : Fine-tuning enabled. Adjust by turning the [BLACK PAINT R/B] knob.
- OFF (Green light on) : Fine-tuning disabled. The [BLACK PAINT R/B] knob is disabled.

Note:

- The feature is not available on the camera if the light of the corresponding button is not lit. Control using this unit is disabled in this case.

● [BLACK PAINT R/B] Black Paint R/B adjustment knob:

For adjusting the R and B levels when the [PAINT] button lights up in orange.

11 Iris Control Unit

● [IRIS MODE] Iris Mode Setting Switch

For selecting an iris mode.

- FULL** : Sets the camera to the manual iris mode. Adjust using the iris setting lever 13. (CLOSE-OPEN)
- PRESET** : Sets the camera to the manual iris mode. Set the variable iris range using the iris setting lever 13 to any 4-f/stops (approximately) range between CLOSE and OPEN. The setting range is ± 2-f/stops from the center value that is specified using the preset level setting knob.
- AUTO** : Sets the camera to the auto iris mode. Adjust the auto iris level using the iris setting lever 13.

Memo:

- When the Gain control unit 5 is set to "ALC", the iris mode becomes "AUTO" regardless of the switch setting. (factory setting) When "ALC" is selected, however, it is still possible to operate the camera according to the status of the iris mode setting switch. (24 page)

● [PRESET LEVEL] Preset Level setting knob

For setting the center value of the 4-f/stops (approximately) range when the [IRIS MODE] switch is set to "PRESET".

- Example

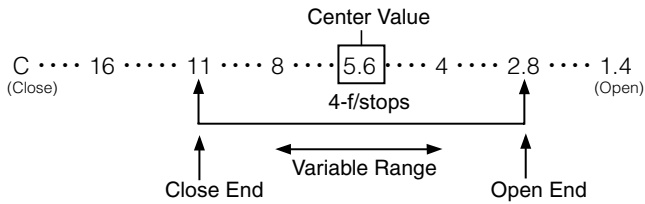

12 Iris F Value Display

Displays the camera's iris F value.

The iris F display on this unit shows the iris F value that is obtained from the camera.

- The display is updated at regular intervals.
- This is displayed as "- - -" if the camera does not support this function, or if the information at the camera's end is not defined or undetected.

■ Display Example

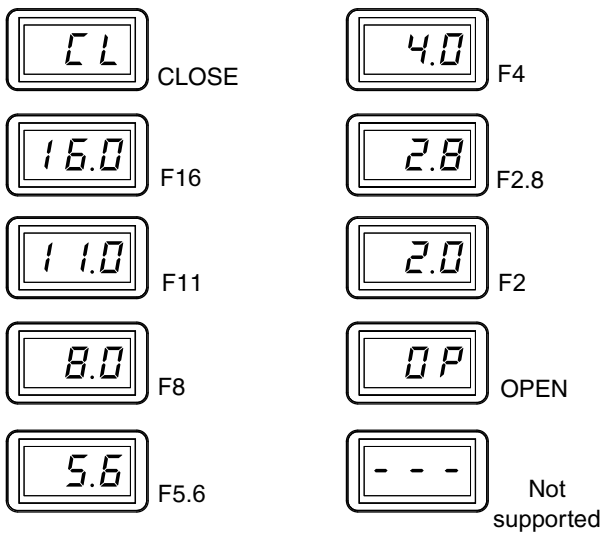

13 [IRIS/AUTO IRIS LEVEL] Iris/Auto Iris Setting Lever

The function varies according to the setting of [IRIS MODE].

Setting of [IRIS MODE]	Function
FULL	For adjusting the iris level. (CLOSE-OPEN)
PRESET	For adjusting the iris level of any 4-f/stops (approximately) range. (CLOSE-OPEN)
AUTO	For adjusting the auto iris level. (OVER-UNDER)

Memo:

- When the [IRIS MODE] is set to "AUTO", you can choose not to adjust the auto iris level (standard fixed auto iris level). (P. 24 page)

Note:

- The lever may become tighter when this unit is used at cold regions.
- When in OPERATE ON mode, iris value is reflected to the camera on the IRIS lever position.

14 [MASTER BLACK] Master Black Setting Knob

For adjusting the pedestal level (master black) as the reference black.

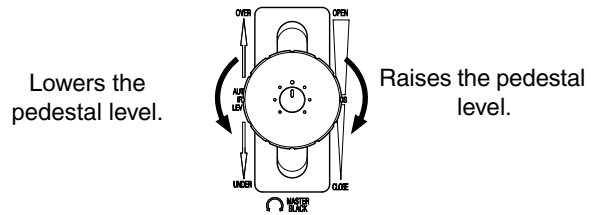

Note:

- The knob may become tighter when this unit is used at cold regions.

15 [TALLY] Tally Indicator

When there is input of tally signals into the tally terminal 22 at the rear of this unit, the indicator lights up.

The light of the indicator varies according to the type of tally signal input.

- TALLY PGM input : Red light
- TALLY PVW input : Green light

Note:

- When there is input of both TALLY PGM and TALLY PVW signals, priority is given to TALLY PGM, and the red light is lit.

Names and Functions of Parts (continued)

Control Panel (continued)

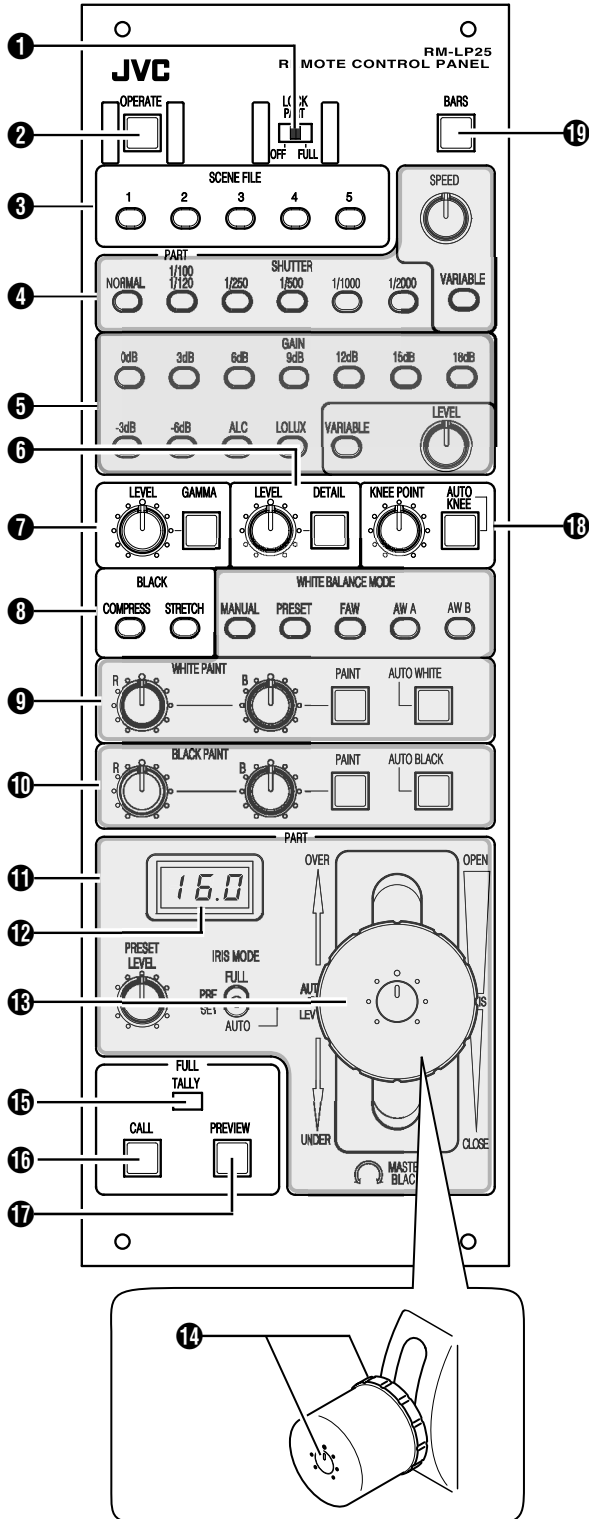

16 [CALL] Send Call Button and Indicator Light

Press this button to call the camera operator. (Calling can be performed without making use of sounds, such as through intercoms.)

It also shows the calling status at the camera's end.

- ON : When you press and hold this button, the indicator lights up in orange, and the tally lamp at the camera's end appears blinking.
- OFF : When you release the button, the indicator light turns off, and the tally lamp at the camera's end stops blinking.
- Blinking orange light : Upon receiving a call (CALL ON signal) from the camera, the indicator starts to blink in orange. Upon receiving a command to cancel a call (CALL OFF signal) from the camera, the indicator light switches to solid green.

Memo:

- When call signals are generated from both the [CALL] button and the camera at the same time, priority is given to the call signal from the camera (blinking orange).

Note:

- The feature is not available on the camera if the light of the corresponding button is not lit. Control using this unit is disabled in this case.

17 [PREVIEW] Preview Button and Indicator Light

Pressing this button sends make output to the preview terminal. (21)

- ON (Orange light on) : When you press and hold this button, the indicator lights up in orange, and output is sent to the make contact.
- OFF (Light off) : When you release the button, the indicator light turns off and output to the make contact is canceled.

18 [KNEE POINT/AUTO KNEE] Knee Control Unit

[AUTO KNEE] Auto Knee button and indicator light:

For specifying whether the knee operation, which compresses video signals beyond a specific level in order to represent the gray level of a highlighted area, is to be performed automatically or manually.

To check the brighter areas, set to "OFF" and adjust the knee point manually.

- ON (Orange light on) : Turns "ON" auto knee control, and the knee point is set automatically.
- OFF (Green light on) : Turns "OFF" auto knee control. Turn the [KNEE POINT] knob and adjust the knee point manually.

● **[KNEE POINT] Knee Point setting knob:**

For adjusting the knee point setting manually when the auto knee button is turned "OFF".

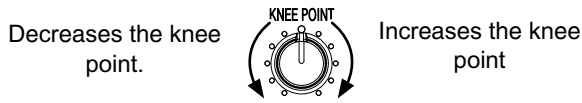

Note:

- The feature is not available on the camera if the light of the corresponding button is not lit. Control using this unit is disabled in this case.

19 [BARS] Video Output Control Button and Indicator Light

- ON (Orange light on) : Outputs the color bar signals.
- OFF (Green light on) : Outputs the camera's video signals.

Note:

- The feature is not available on the camera if the light of the corresponding button is not lit. Control using this unit is disabled in this case.

Rear/Side of Remote Control Panel

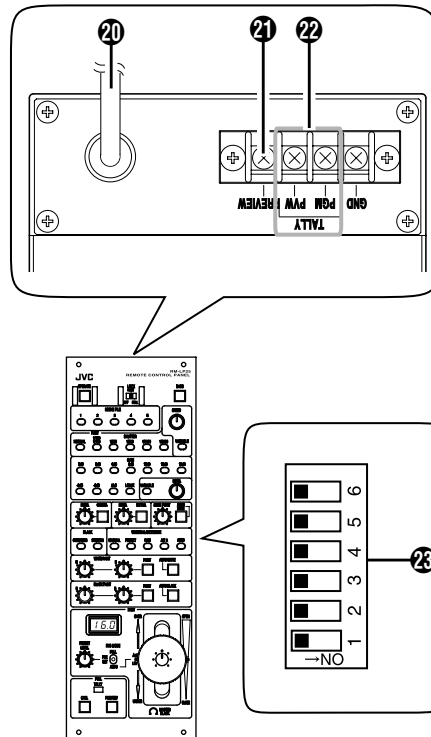

20 Cable

Cable for connecting to the camera. (Cable length: 5 m)

21 [PREVIEW] Preview Terminal (Output) (22 page)

This is the terminal for sending output to the make contact when you press and hold the [PREVIEW] button 17.

22 [TALLY] Tally Terminal (Input) (22 page)

This is the terminal for inputting tally signals, such as those from the image switch that the controlled camera is connected to.

[PGM]:

Connects the tally signal when the controlled camera is selected as the program. When input signals are received, the tally indicator 15 lights up in red.

[PVW]:

Connects the tally signal when the controlled camera is selected as the preview. The tally indicator 15 lights up in green.

Note:

- When there is input of both [PGM] and [PVW] signals at the same time, priority is given to [PGM], and the tally indicator 15 lights up in red.

23 DIP Switch (24 page)

A part of the features can be specified according to the usage of individual users.

Exemplary System

Connection:

Connect the remote control unit cable to the REMOTE terminal.

To reduce the emission of unwanted radio waves, be sure to attach the provided clamp filter as shown in the figure below.

- Attach the clamp filter as close to this device as possible, as shown in the figure.

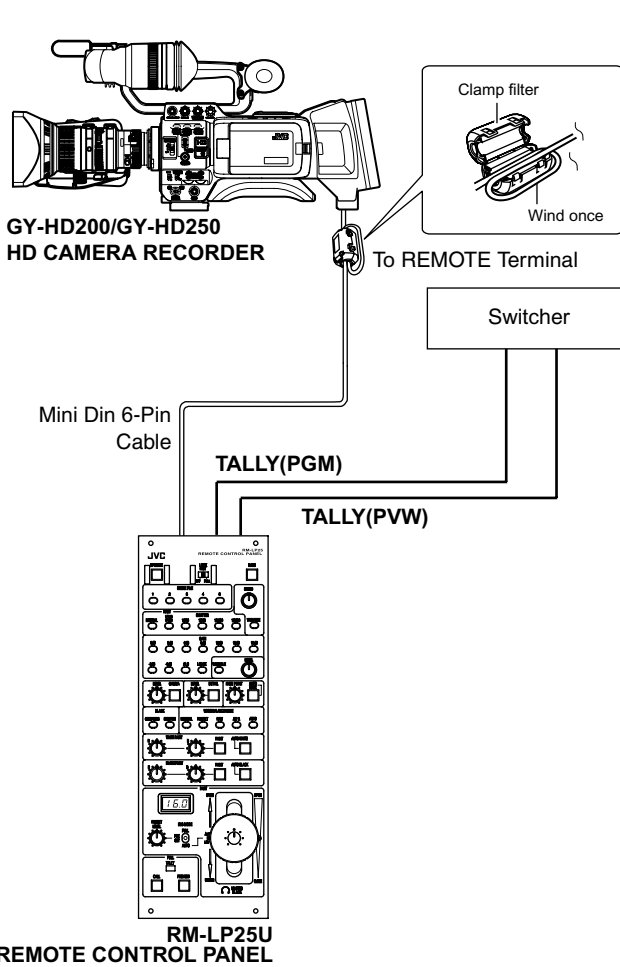

Note:

- Turn the power off when connecting.

Setup

1 Set up by connecting this product to GY-HD250 or GY-HD200.

- Connect according to the instruction manual of the devices in use, and set accordingly.

2 Set this product as follows:

- Set the [LOCK] switch to "OFF".
- Set the [OPERATE] button to "OFF" (light off).

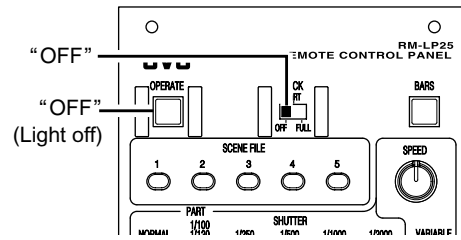

Note:

- To enable iris control using this product, set the lens iris mode of the camera to "AUTO" or "A".

3 Press the [OPERATE] button.

- The [OPERATE] button starts to blink in orange, and initial communication with the connected camera starts.
- After initial communication is complete, the [OPERATE] button switches to solid orange. Control of the camera using this product is now enabled.

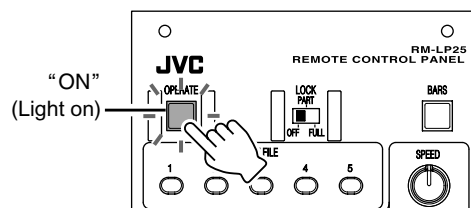

Memo:

- The time required for initial communication may be extremely short for some cameras, such that the button only appears blinking for an instant, after which it lights up in solid orange.

Shutter Settings

For specifying the shutter settings.

1 Press any of the shutter speed buttons.

- The selected shutter speed button lights up in orange, and the speed button that was previously selected turns green.

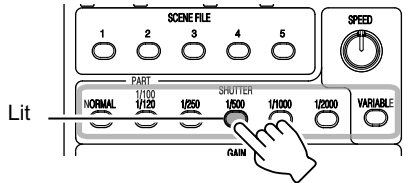

Memo:

- The shutter speed that can be selected varies according to the connected camera. Shutter speed buttons that are available at the connected camera's end light up in green and are available for selection, while those shutter speed buttons that are not found at the camera's end are not lit and are disabled.

Note:

- When "ALC" is selected at the GAIN control unit (5), and functions as "ALC+EEI", the shutter becomes "EEI", and all button lights turn off and their selection is disabled.

■ Shutter Speed Selection Buttons

Setting Value	Function
NORMAL	Sets the shutter to the default value. Frame rate 60/30 setting F 1/60 Frame rate 50/25 setting F 1/50 Frame rate 24 setting F 1/48
1/100 · 1/120	Sets the shutter to the displayed value. Frame rate 60/30 or 24 setting F 1/100 Frame rate 50/25 setting F 1/120
1/250	Sets the shutter to the displayed value.
1/500	
1/1000	
1/2000	
VARIABLE	Sets shutter to the variable scan mode. In this case, set the shutter speed using the [SPEED] knob. When shooting PC monitors, selecting this mode helps to remove black bands or flickering during vertical synchronization.

■ [SPEED] Variable Scan Speed setting knob

This is the knob for setting the shutter speed when the [VARIABLE] shutter speed button is selected.

The setting range varies according to the connected camera.

Gain Settings

For specifying the gain settings.

1 Press any of the gain value buttons.

- The selected gain value button lights up in orange, and the gain value button that was previously selected turns green.

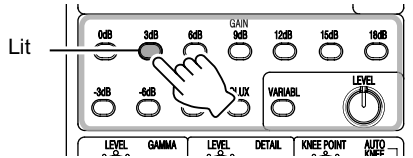

■ [GAIN] Gain Selection Button

Setting Value	Function
-6dB	Sets gain to the displayed value.
-3dB	
0dB	
3dB	
6dB	
9dB	
12dB	
15dB	
18dB	
ALC	Sets the gain value automatically.
LOLUX	Sets to the high sensitivity mode.
VARIABLE	Sets to the variable gain mode. In this case, set the gain value using the [LEVEL] knob.

■ [LEVEL] Variable Gain Selection Button

This is the knob for setting the gain value when the [VARIABLE] gain button is selected.

The setting range varies according to the connected camera.

Memo:

- The gain values that can be selected vary according to the connected camera. For gain values that are not available at the connected camera, the light of the corresponding buttons are turned off and disabled.
- “ALC” runs either in the mode when the gain value is automatically set (ALC), or when the gain value and shutter are automatically set (ALC+EEI), depending on the type of camera connected. When a connected camera allows running in both modes, you can select the mode to run using the DIP switch settings on this product. (☞ 24 page)

Gain Action	Shutter Operation
ALC	Enables free selection.
ALC+EEI	Shutter switches to the automatic adjustment mode (EEI), and all shutter button lights turn off and their selection is disabled.

Memo:

- When “ALC” is selected, the [IRIS MODE] becomes “AUTO” (factory setting) regardless of the switch settings of this product. However, it is possible to assign priority to the [IRIS MODE] switch settings of this product using the DIP switch settings. (☞ 24 page)

White Balance Adjustment

For specifying the white balance settings.

Setup:

- Set the [BARS] button to “OFF”.
- Place a white object near the center of the screen under the same lighting conditions as the target subject and zoom in to fill the screen with white.
- Set the optical filter of the camera according to the color temperature.

Automatic Adjustment

1 Set [WHITE BALANCE MODE] to “AW A” or “AW B”.

2 Press [AUTO WHITE] (push once).

- The [AUTO WHITE] indicator lights up in orange.
- Auto white balance adjustment is performed and the value stored in the camera.
- After the value is successfully stored, the [AUTO WHITE] indicator turns green.

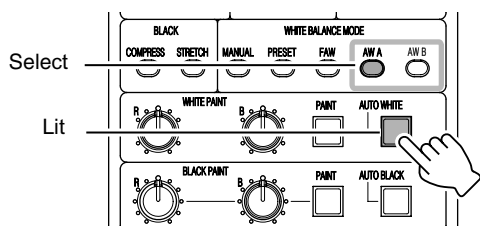

Note:

- When error occurs during the automatic adjustment, the [AUTO WHITE] indicator lights up in green after blinking in orange for about 5 seconds. Identify the cause of the error (lighting, filter settings, or object) and adjust again.
- The error cause is displayed on the viewfinder of the camera. For details on the display, refer to [INSTRUCTIONS] of the connected camera.

3 Fine-tune the R- and B-gain values whenever necessary.

- Press [WHITE PAINT], and use the [WHITE PAINT R/B] knob to fine-tune the R- and B-gain values.

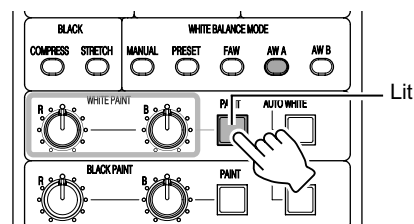

Memo:

- You can store different R- and B-gain values after adjustment separately in “AW A” and “AW B”.

Note:

- The adjustable range of the “R” and “B” knobs may vary according to the color temperature difference of the object.

Manual Adjustment

1 Select “MANUAL” under [WHITE BALANCE MODE].

2 Adjust the white balance value manually using the [WHITE PAINT R/B] knob.

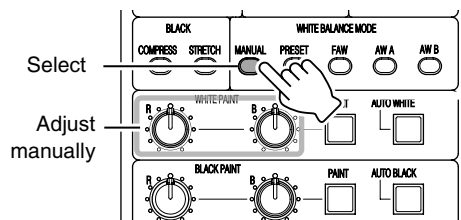

Black Balance Adjustment

For specifying the black balance settings.

Setup:

- Set the [BARS] button to "OFF".

Automatic Adjustment

1 Press [AUTO BLACK] (push once).

- The [AUTO BLACK] indicator lights up in orange.
- Auto black balance adjustment is performed and the value stored in the camera.
- After automatic adjustment is complete, the [AUTO BLACK] indicator lights up in green.

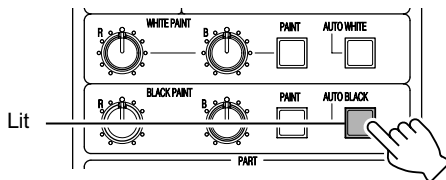

Note:

- When error occurs during the automatic adjustment, the [AUTO BLACK] indicator lights up in green after blinking in orange for about 5 seconds. Identify the cause of the error (lens iris cannot be closed, etc.) and adjust again.
- The error is displayed on the viewfinder of the camera. For details on the display, refer to [INSTRUCTIONS] of the connected camera.
- The feature is not available on the camera if the [AUTO BLACK] button is not lit. In this case, auto black does not start up even if you press the [AUTO BLACK] button.
- When the [BLACK PAINT] is set to "ON", it changes to "OFF" after automatic adjustment is complete.

Manual Adjustment

Black Balance

1 Press [BLACK PAINT].

- The [BLACK PAINT] indicator lights up in orange.

2 Adjust the black balance value manually using the [BLACK PAINT R/B] knob.

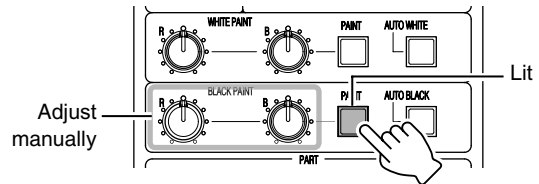

Note:

- The feature is not available on the camera if the [BLACK PAINT] button is not lit. Black balance cannot be adjusted in this case.

Scene File

You can save various settings of this product according to the different shooting conditions as scene files. You can save up to five different scene files, and recall them simply by pressing the button.

You can also identify the status of the scene files based on the indicator light of the button.

- Not lit : No scene file has been stored.
- Lights up in green : Scene files have already been stored.
- Lights up in orange : Scene files are being called.

You can use the buttons to store new scene files, or load/clear preset scene files.

Storing a New Scene File

To save the current settings in the [SCENE FILE] button:

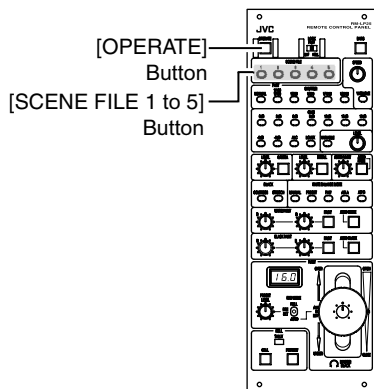

1 Check to ensure that the indicator light of the [SCENE FILE] button to register the settings is "OFF" or "lit in green".

Memo:

- A scene file is currently being called if the [SCENE FILE] button lights up in orange. In this case, the following operation is disabled.

2 Press and hold the [SCENE FILE] button where the settings are to be stored for at least two seconds.

- The [SCENE FILE] button and the [OPERATE] button blink in orange, and storing starts.

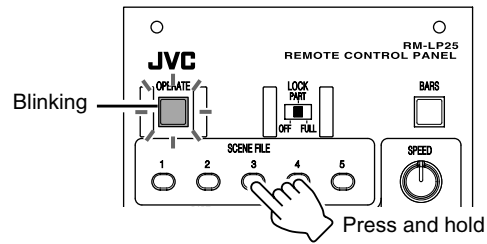

3 Storing is complete.

- The [OPERATE] button indicator switches back to a solid orange light, and the [SCENE FILE] button where the settings are stored also lights up in orange.

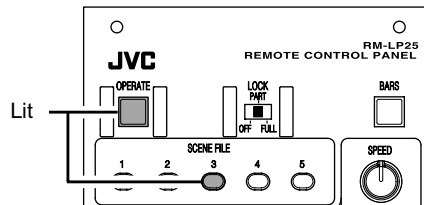

Memo:

- If another [SCENE FILE] button is already lit in orange when you are storing a new scene file, this button switches to a solid green light.

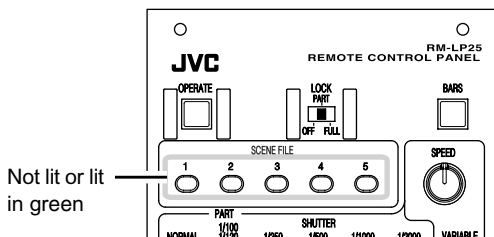

Scene File (continued)

Loading a Scene File

To call a preset scene file:

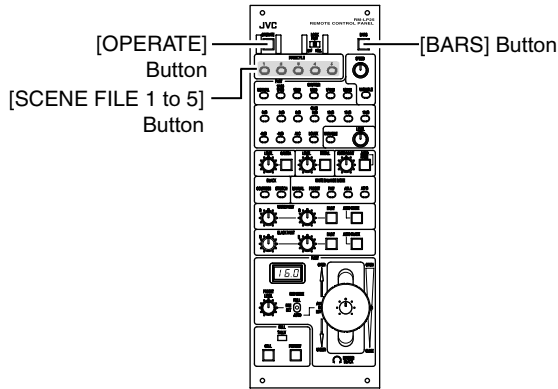

1 Check to ensure that the [SCENE FILE] button that contains the settings you want to recall is "lit in green".

Memo:

- No setting is stored in the scene file if the light of the corresponding [SCENE FILE] button is not lit. In this case, the following operation is disabled.

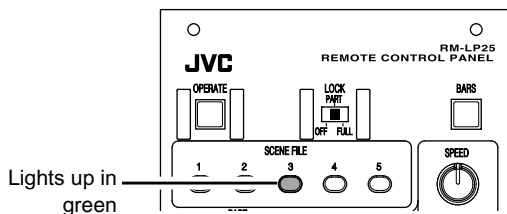

2 Press the [SCENE FILE] button that contains the settings you want to recall.

- The [SCENE FILE] button and the [OPERATE] button blink in orange, and loading starts.
- After loading, initial communication with the camera is performed. During communication with the camera, the [SCENE FILE] button lights up in orange, while the [OPERATE] button blinks in orange. The light of all other buttons and indicators are automatically turned off.

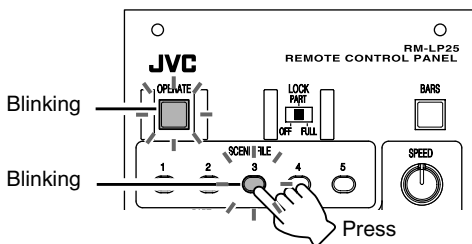

3 Loading is complete.

- The [OPERATE] button switches back to a solid orange light, and the buttons and indicators of all other features are also lit according to their preset status.

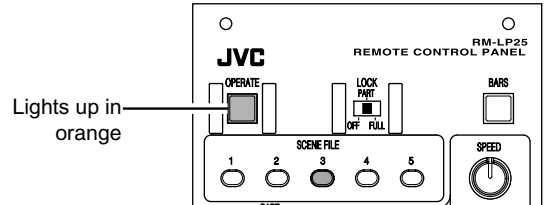

Memo:

- If another [SCENE FILE] button is already lit in orange when you are loading a scene file, this button switches to a solid green light.

Clearing a Scene File

To delete a preset scene file:

1 Check to ensure that the [SCENE FILE] button that contains the settings you want to clear is "lit in orange" or "lit in green".

Memo:

- No setting is stored in the scene file if the light of the corresponding [SCENE FILE] button is not lit. In this case, the following operation is disabled.

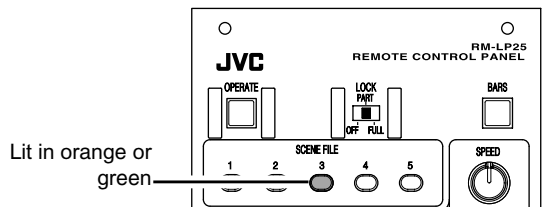

2 Press and hold (for at least two seconds) the [SCENE FILE] button for which you want to clear the settings as well as the [BARS] button at the same time.

- The [SCENE FILE] button and the [OPERATE] button blink in orange, and clearing starts.

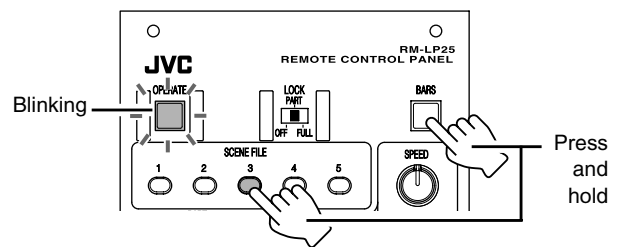

3 Clearing is complete.

- The [OPERATE] button switches back to a solid orange light, and the light of the [SCENE FILE] button for which settings have been deleted is turned off.

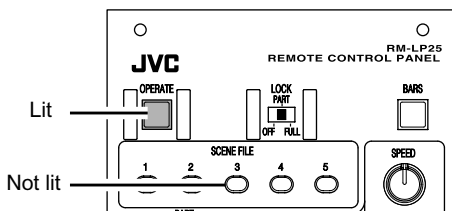

Memo:

- After clearing the settings, the light of the [SCENE FILE] button on the remote control is turned off, and the status of all other buttons and indicators remain unchanged.

List of Supported Features in Scene Files

The following are functions that can be stored in scene files.

No.	Function	Function Description	Storage in scene file
			○: Possible ×: Not possible
①	LOCK	OFF/PART/FULL	×
②	OPERATE	ON/OFF	×
④	SHUTTER	Shutter Mode	○
		V.SCAN Data	○
⑤	GAIN	Gain Mode	○
		V.GAIN Data	○
⑥	DETAIL	ON/OFF	○
		LEVEL	Detail Level
⑦	GAMMA	ON/OFF	○
		LEVEL	Gamma Level
⑧	BLACK	STRETCH/ COMPRESS/NORMAL	○
⑨	WHITE BALANCE MODE	White Balance Mode	○
	WHITE PAINT	White Paint Value of AW A	○
		White Paint Value of AW B	○
	PAINT	MANU White Balance Value	○
⑩	BLACK PAINT	Black Paint Value	○
	PAINT	ON/OFF	○
⑪	IRIS MODE	FULL/PRESET/AUTO	×
	PRESET LEVEL	PRESET Center Value	○
⑫	IRIS/AUTO	Manual Iris Level	×
		Auto Iris Level	×
⑭	MASTER BLACK	Master Black Level	○
⑮	AUTO KNEE	ON/OFF	○
		LEVEL	Knee Point
⑰	BARS	ON/OFF	×

Adjustment of Indicator's Brightness

The brightness of the indicator light on the control panel can be adjusted in five levels.

Indicators for which brightness cannot be adjusted:

- [CALL] button
- [PREVIEW] button
- [TALLY] indicator

1 Set the [LOCK] switch to "OFF".

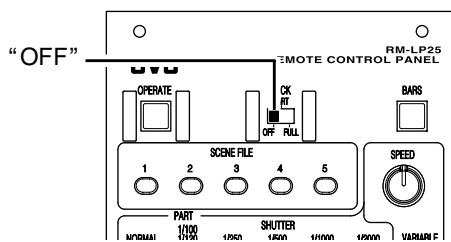

2 Press and hold the [BARS] button, and operate the [IRIS/AUTO IRIS LEVEL] lever at the same time.

- Doing so switches to the brightness adjustment mode, and the brightness of the indicator light changes.

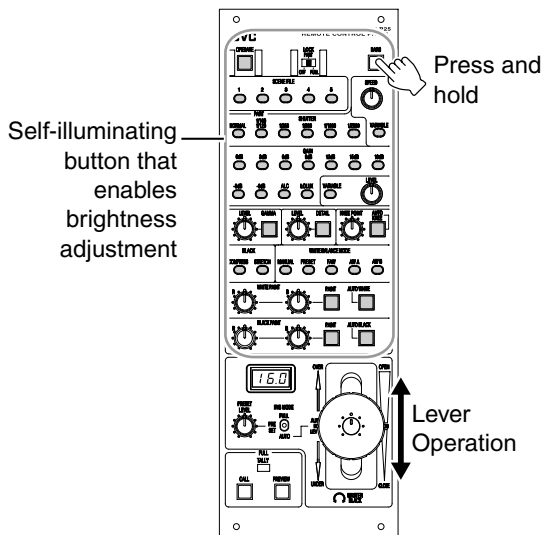

Note:

- Normal operation is disabled when in the brightness adjustment mode. However, the [OPERATE] button remains enabled.

3 Determine the brightness level.

- Releasing the [BARS] button upon selecting a random brightness level restores the normal mode, and the corresponding brightness level is stored.

Input/Output of Rear Ports

The tally circuit comes with two input systems, namely contact input and open collector input.

This is set to contact input in the factory settings. You can change this to open collector input via settings of the DIP switch at the side of the main unit.

Remove the cover at the side of this product, and set the tally circuit supply system using DIP switch no. 6. (☞ 24 page)

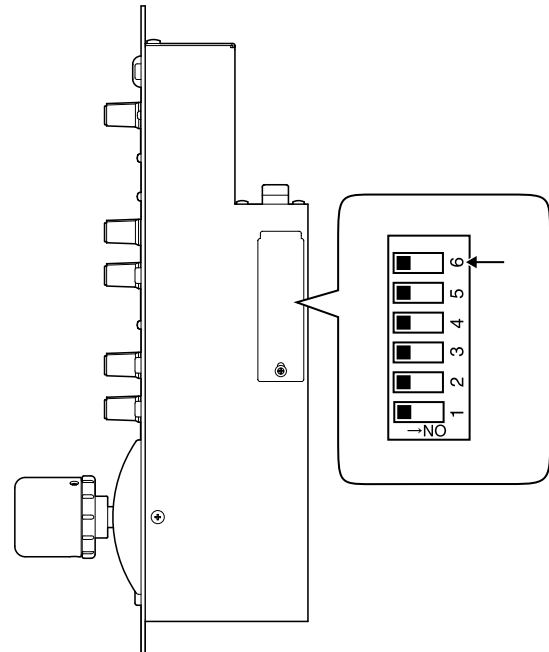

Tally Input Terminal

Input Conditions

- No-voltage relay contact a input, or open collector input (contact a: "Open" at normal times, and "Closed" during Tally)
- 10 k Ω for internal, connected to 5 V power
- Input signals can be set using the DIP switch (see 24 page "DIP Switch 6")

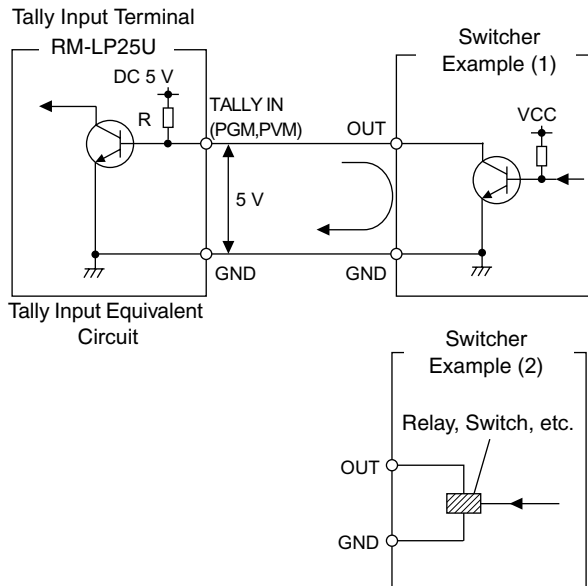

PREVIEW Output Terminal

Output Conditions

- Equivalent to open collector output
- External connection capacity DC 5 V, 10 mA
- Polarity: "HIGH" when normal and "LOW" during PREVIEW

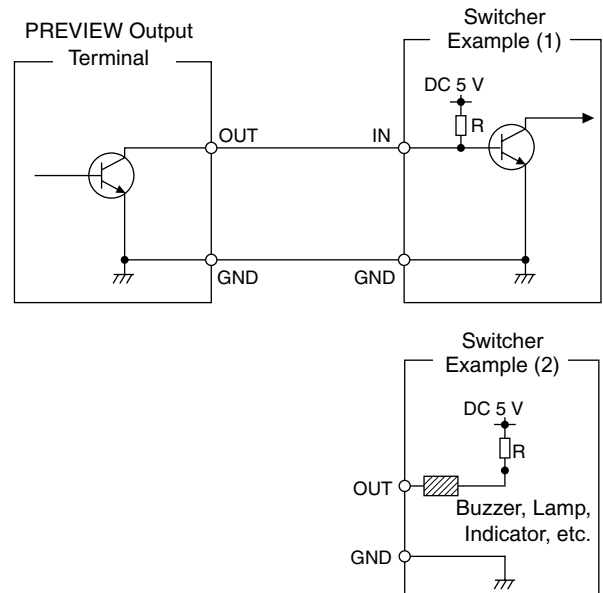

Operation

Setting Selection DIP Switch

You can partially switch the settings of features (factory settings). All switches are set to "OFF" in the factory settings.

Note:

- Be sure to change the DIP switch settings under Operate OFF mode.

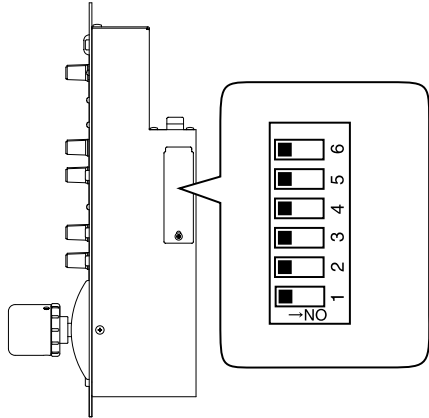

■ DIP Switch 1

For setting the [GAIN] selection button's "ALC" feature.

Function	For selecting the feature to use when "ALC" is selected, if the connected camera comes with both the (ALC) mode, which automatically adjusts the gain value only, as well as the (ALC+EEL) mode, which adjusts both the gain and shutter values automatically.		
Setting	OFF	<input type="checkbox"/>	Use as "ALC".
	ON	<input checked="" type="checkbox"/>	Use as "ALC+EEL".

Note:

- For GY-HD200 and GY-HD250, this setting is invalid as the gain value and shutter are standard settings when automatically set (ALC+EEL). To use GY-HD200 and GY-HD250 when only the gain value is automatically set (ALC), please consult your nearest JVC's authorized dealers.

■ DIP Switch 2

For setting the [AUTO IRIS LEVEL] feature.

Function	For specifying whether the "IRIS" lever is to be used as the [AUTO IRIS LEVEL] adjustment lever when the iris mode is set to "AUTO".		
Setting	OFF	<input type="checkbox"/>	Use as adjustment lever for "AUTO IRIS LEVEL".
	ON	<input checked="" type="checkbox"/>	Use as adjustment lever for "AUTO IRIS LEVEL" disabled. (Operation is disabled, and the AUTO IRIS LEVEL is fixed to the standard value.)

■ DIP Switch 3

For setting the [IRIS MODE] when "ALC" is selected for the [GAIN] button.

Function	For setting whether the iris mode is to be forcibly switched to "AUTO" when "ALC" is selected for the [GAIN] button.		
Setting	OFF	<input checked="" type="checkbox"/>	Forcibly set to "AUTO".
	ON	<input type="checkbox"/>	Not forcibly set to "AUTO". (Iris mode complies with the switch status.)

■ DIP Switch 4

Reserved switch. Make sure that this is set to "OFF" during use.

■ DIP Switch 5

Reserved switch. Make sure that this is set to "OFF" during use.

■ DIP Switch 6

For setting input signals of the [TALLY] terminal.

Function	For setting the input signals of the [TALLY] terminal.		
Setting	OFF	<input type="checkbox"/>	Use as "contact input system".
	ON	<input checked="" type="checkbox"/>	Use as "open collector input system". HIGH: ON, LOW: OFF

Operable Features

Features that can be controlled using this product vary according to the camera connected.

Features that are enabled/disabled when GY-HD250/GY-HD251/GY-HD200/GY-HD201 are connected are shown below.

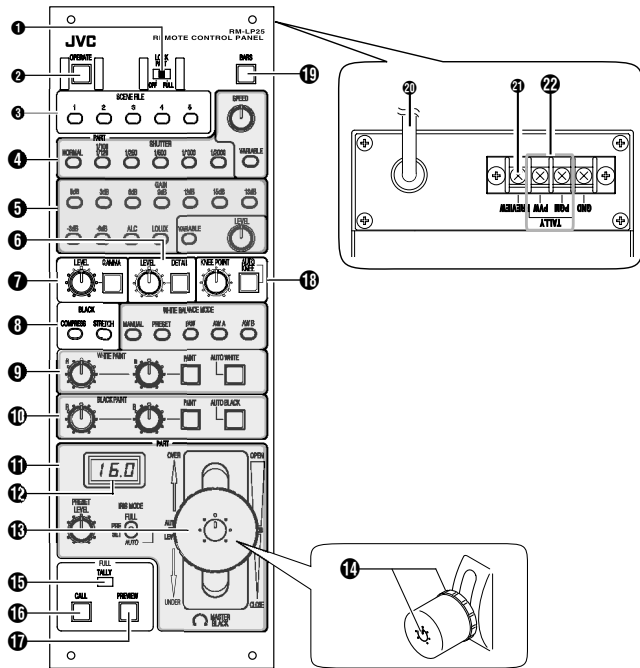

No.	Function		GY-HD250	GY-HD200
			GY-HD251	GY-HD201
○: Enabled, ×: Disabled				
4	SHUTTER	NORMAL	○	○
		1/100 · 1/120	○	○
		1/250	○	○
		1/500	○	○
		1/1000	○	○
		1/2000	○	○
		VARIABLE SPEED	×	×
5	GAIN	-6dB	×	×
		-3dB	×	×
		0dB	○	○
		3dB	○	○
		6dB	○	○
		9dB	○	○
		15dB	○	○

No.	Function		GY-HD250	GY-HD200
			GY-HD251	GY-HD201
○: Enabled, ×: Disabled				
5	GAIN	18dB	○	○
		ALC	○	○
		LOLUX	×	×
		VARIABLE LEVEL	×	×
6	DETAIL	LEVEL	○	○
7	GAMMA	LEVEL	○*	○*
8	BLACK	NORMAL	○	○
		STRETCH	○	○
		COMPRESS	○	○
9	WHITE BALANCE MODE	MANUAL	○	○
		PRESET	○	○
		FAW	○	○
		AW A	○	○
	AW B	○	○	
10	WHITE PAINT	○	○	
	AUTO WHITE	○	○	
10	AUTO BLACK	×	×	
	BLACK PAINT	○*	○*	
11	IRIS	Iris Control Unit	○	○
12		Iris F Value Display	○*	○*
13		LEVEL	○	○
14	MASTER BLACK	○	○	
15	TALLY	○*	×	
16	CALL	○*	×	
17	PREVIEW	○	○	
18	AUTO KNEE	○	○	
	KNEE POINT	○	○	
19	BARS	○	○	
22	TALLY(PGM)	○	○	
	TALLY(PVW)	○	○	

* The above feature may not function depending on the version of the camera's software. For details, please consult JVC's authorized dealers.

Operation of Connected Camera

When RM-LP25U is connected to a camera, all features that are available on RM-LP25U can only be controlled via RM-LP25U, and control of these features using the camera is disabled.

Switches on the camera that are disabled, as well as disabled menu items are as follows.

Switches that are disabled

- GAIN
- SHUTTER*
- WHT.BAL
- FULL AUTO*
- User 1, 2 and 3 with the following features assigned
BARS
B.STRETCH1-5
B.COMPRESS1-5
AE LEVEL+
AE LEVEL-

Memo: _____

- SHUTTER will also be disabled if the setting is "VARIABLE" or below "1/30".
- FULL AUTO is forcibly set to "OFF" regardless of the switch status.

Menu items that are disabled

Menu Page	Function	Menu Display	
		GY-HD250 GY-HD251	GY-HD200 GY-HD201
CAMERA OPERATION	AE LEVEL	REMOTE	REMOTE
	BARS	REMOTE	REMOTE
CAMERA PROCESS[1/2]	MASTER BLACK	REMOTE	REMOTE
	DETAIL	REMOTE	REMOTE
CAMERA PROCESS[2/2]	BLACK	REMOTE	REMOTE
	KNEE	REMOTE	REMOTE
	LEVEL	REMOTE	REMOTE
ADVANCED PROCESS	CINEMA	[OFF]*	[OFF]*
	GAMMA	[STANDARD]*	[STANDARD]*
		[CINEMA]*	[CINEMA]*
		[FILMOUT]*	[FILMOUT]*
LEVEL	REMOTE	REMOTE	
WHITE BALANCE	WHITE PAINT R	REMOTE	REMOTE
	WHITE PAINT B	REMOTE	REMOTE

Memo: _____

- CINEMA is forcibly set to "OFF". To adjust MATRIX, make use of the menu on the camera.
- GAMMA is fixed to the menu setting value of camera before connecting remote control. However, it is forced to "STANDARD" if the menu setting value of camera before connecting remote control is "OFF".

Remote Connector Specifications

Remote Cable

Manufactured by Hosiden Corporation (Length: 5 m)

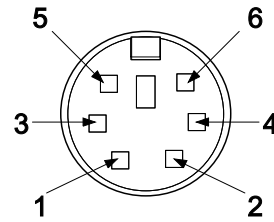

Pin No.	Signal	Description	Level	IN/OUT
1	GND	GND	—	—
2	RM/CTL	Operate Control	+5V	OUT
3	GND	GND	—	—
4	SID2	Received Data	+5V	IN
5	SID1	Transmitted Data	+5V	OUT
6	+9V	Vcc	+9V	IN

Troubleshooting

Troubleshooting	Check Point	Reference Page
Power does not turn ON/OFF upon pressing the Operate button.	<ul style="list-style-type: none"> ● Is the Operation Lock switch set to "PART" or "FULL"? Set to "OFF". ● Are the cables properly connected? ● Is the power of the connected camera functioning normally? 	<p>☞ 7 page</p> <p>☞ 14 page</p>
Unable to select "-3dB" or "-6dB" of the gain selection button when they are pressed.	<ul style="list-style-type: none"> ● Is the "-3dB" or "-6dB" button lit in green? Features (Options) that are not available at the camera's end are not lit and are disabled. 	☞ 16 page
Function cannot be turned ON (orange light on) after pressing the white paint button.	<ul style="list-style-type: none"> ● Is the white balance selection set to "PRESET" or "FAW"? Select "AW A" or "AW B". 	☞ 9 page
Function cannot be turned OFF (green light on) after pressing the white paint button.	<ul style="list-style-type: none"> ● Is the white balance selection set to "MANUAL"? When "MANUAL" is selected, the WHITE PAINT R/B knob is enabled at all times, and therefore the white paint button remains ON (orange light on). 	☞ 9 page
Lamp light is dull.	<ul style="list-style-type: none"> ● The lamp brightness of this product can be adjusted. 	☞ 22 page
The lens iris of the camera does not move even when the iris lever is moved.	<ul style="list-style-type: none"> ● Is the lens iris mode set to "MANUAL"? Set it to "AUTO" or "A". 	☞ 14 page

Dimensional Outline Drawing (Unit: mm)

Specifications

Cameras that can be connected

- : GY-HD250 Series
- : GY-HD200 Series

Power Supply

: +9 V ± 0.5 V

Power Consumption:

: Approx. 2 W and below

Ambient Temperature

: -5°C to 40°C

Allowable Operating Humidity

: 30% RH to 80% RH

Mass

: 2.4 kg

Cable Length

: 5 m

Installation Angle

: Within ±45°

Attachments

- Instruction Manual..... 1
- Warranty..... 1
- Clamp Filter (☞ 14 page)..... 1

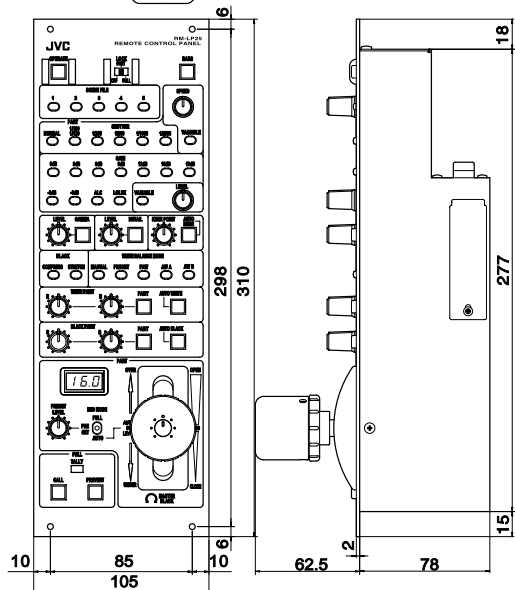
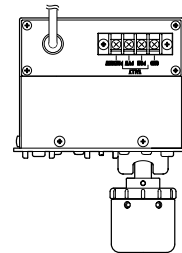

※ The specifications and appearance of this product and other related products may be modified for improvement without prior notice.

RM-LP25U

REMOTE CONTROL PANEL

遥控操作单元

JVC

贩卖商名 杰伟世（中国）投资有限公司
住 址 北京市朝阳区光华路12A号北京科伦大厦316室
出 版 日 2007年6月1日

日本JVC公司

© 2007 Victor Company of Japan, Limited

LST0594-001A

Free Manuals Download Website

<http://myh66.com>

<http://usermanuals.us>

<http://www.somanuals.com>

<http://www.4manuals.cc>

<http://www.manual-lib.com>

<http://www.404manual.com>

<http://www.luxmanual.com>

<http://aubethermostatmanual.com>

Golf course search by state

<http://golfingnear.com>

Email search by domain

<http://emailbydomain.com>

Auto manuals search

<http://auto.somanuals.com>

TV manuals search

<http://tv.somanuals.com>