

jWIN®

Compact Disc Player with Anti-Shock System

JX-CD680

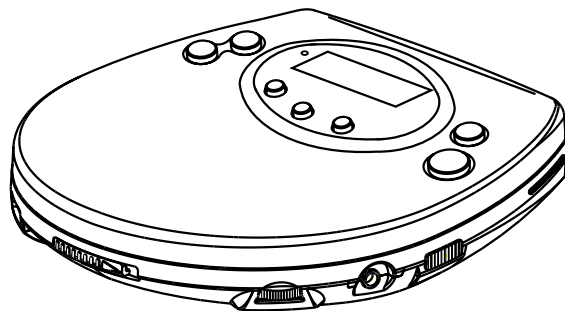

INSTRUCTION MANUAL

PLEASE READ THE INSTRUCTION CAREFULLY BEFORE OPERATING THIS UNIT.

WARNING

To prevent fire or shock hazard, do not expose this appliance to rain or moisture.

IMPORTANT

Since the CD circuitry may cause interference to other radio tuners nearby, switch this unit off when not in use or move it away from the affected radio tuner.

This device complies with Part 15 of the FCC Rules, operation is subject to the following two conditions: (1) This device may not cause harmful interference, and (2) this device must accept any interference received, including interference that may cause undesirable operation.

NOTE : This equipment has been tested and found to comply within the limits for a Class B digital device, pursuant to Part 15 of the FCC Rules. These limits are designed to provide reasonable protection against harmful interference in a residential installation. This equipment generates, uses and can radiate radio frequency energy and, if not installed and used in accordance with the instruction, may cause harmful interference to radio communications. However, there is no guarantee that interference will not occur in a particular installation. If this equipment does cause harmful interference to radio or television reception, which can be determined by tuning the equipment off and on, the user is encouraged to try to correct the interference by one or more of the following measures:

- Reorient or relocate the receiving antenna.
- Increase the separation between the equipment and receiver.
- Connect the equipment into an outlet on a circuit different from that to which the receiver is connected.
- Consult the dealer or an experienced radio / TV technician for help.

SAFETY CERTIFICATION

This Compact Disc Player is made and tested to meet safety standards of the FCC, requirements and compliance with safety performance of the U.S. Department of Health and Human Services, and also with FDA Radiation Performance Standards 21 CFR Subchapter J.

DANGER

	LASER SAFETY This unit employs an optical laser beam system in the CD mechanism, designed with built-in safeguards. Do not attempt to disassemble, refer to qualified service personnel. Exposure to this invisible laser light beam may be harmful to the human eye.
INVISIBLE LASER RADIATION WHEN OPEN AND INTER- LOCK FAILED OR DEFEATED. AVOID DIRECT EXPOSURE TO LASER BEAM.	THIS IS A CLASS-1 LASER PRODUCT. USE OF CONTROLS, OR ADJUSTMENTS OR PROCEDURES OTHER THAN THOSE SPECIFIED HEREIN, MAY RESULT IN HAZARDOUS LASER LIGHT BEAM EXPOSURE.

SAFETY PRECAUTIONS

1. Do not open the cabinet. Refer servicing to qualified personnel only.
2. Do not expose to excessive heat, direct sunlight, dust, moisture, vibration or shock.
3. Use ONLY the AC adaptor provide, others may damage your unit. Disconnect from the wall outlet when the set is not to be used for an extended period of time.
4. When cleaning your unit, use a soft dry cloth, do not use solvents or commercially available cleaners as they may damage or discolor the finish.
5. Do not wear headphones while operating a motor vehicle, this could create a traffic hazard and is illegal in many areas.
6. The headphones supplies with your unit provide super stereo listening while allowing you to hear outside sounds when listening at normally low volume levels. Listening at extremely high volume levels minimizes the intrusion of outside noise/sounds.
7. If you notice that the sound has become weak or distorted, this is an indication that your batteries are low. Replace with new or recharged (see "BATTERY OPERATION")

LOCATION OF CONTROLS

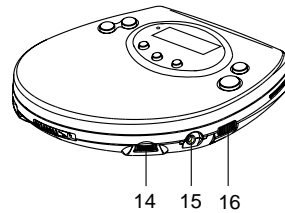
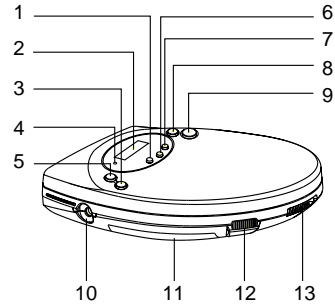

- | | |
|----------------------------------|-------------------------|
| 1. Mode Button | 9. Play / Pause Button |
| 2. LCD Display | 10. DC Jack |
| 3. Backward Skip / Search Button | 11. Battery Cover |
| 4. Charge Indicator | 12. Hold Switch |
| 5. Forward Skip / Search Button | 13. CD Lid Open Switch |
| 6. Program Button | 14. Volume Control Knob |
| 7. Anti Shock Button | 15. Phones Jack |
| 8. Stop Button | 16. Bass Boost Switch |

2

POWER SOURCES NORMAL BATTERIES / AC ADAPTOR

Battery Power Operation

- Open the battery compartment cover and insert two "AA" alkaline batteries inside the battery compartment. Follow the polarity as indicated in the battery compartment.
- Close the battery compartment cover.

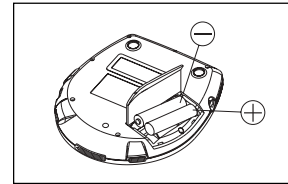

AC Operation

- Insert the DC plug, at the end of the AC adaptor cord into the DC input jack.
- Plug the AC adaptor into a 120V AC power outlet socket.

Note: If the AC plug of this unit does not fit in your AC outlet, a plug adaptor (Not supplied) should be used. Consult your local dealer on the type of plug adaptor required.

LOW BATTERY ALERT

When the Batt. indicator appears in the LCD panel, this means that the batteries are losing their charge. In this case the CD player will not function properly and the batteries must be replaced. In case the Ni-cd rechargeable are being used follow the instruction on how to recharge the batteries detailed in the owners manual.

Battery Type	Average Playing Time (Continuous Play)	
	Normal Play Mode	Anti-Skip Play Mode
Alkaline "AA"	Approx. 9 hrs.	Approx. 8 hrs.
Ni-CAD Rechargeable (min specification recommended 1.2V - 650mA)	Approx. 3.5 hrs.	Approx. 2.5 hrs.

Note: Zinc/Carbon, or Zinc/Chloride type batteries are not recommended for this unit as their use will result in extremely short playing times. Wherever possible and for economy, it is recommended that the mains adaptor supplied with this unit is used.

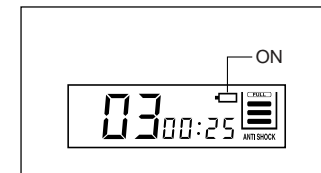
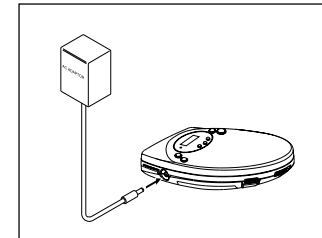

3

CHARGING AND USE OF RECHARGEABLE BATTERIES

Rechargeable Battery Operation

This unit can fully recharge specified rechargeable batteries, in approximately 15 hours. The rechargeable batteries (NOT supplied) should be recharged before they are used for the first time if they are low in power or they have not been used for a long period (over 60 days).

1. Open the battery compartment cover and insert two of the recommended rechargeable batteries, matching polarity. (1.2V 650mA)

BOTH BATTERIES MUST BE OF RECHARGEABLE NICKEL-CADMIUM TYPE, OTHERWISE THE BATTERIES MAY EXPLODE OR LEAK.

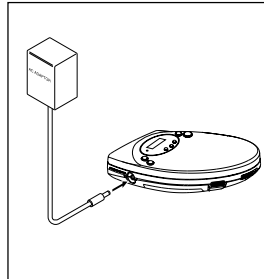
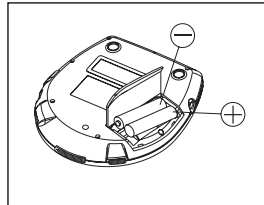
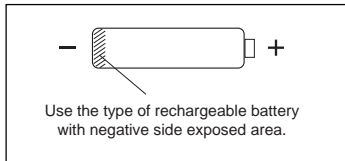

2. Connect the supplied AC adaptor's plug to the DC input jack and corresponding end to an AC household outlet.

USE ONLY THE AC ADAPTOR SUPPLIED WITH THE SET FOR CHARGING.
Note : Charge light will illuminate.

3. After 15 hours, please unplug the AC adaptor.
DO NOT CHARGE CONTINUOUSLY FOR 24 HOURS OR MORE. DOING SO CAN CAUSE THE PERFORMANCE OF THE RECHARGEABLE BATTERY TO DETERIORATE.
4. If the operating time decreases drastically even when the rechargeable nickel-cadmium batteries are properly recharged, purchase a new set of rechargeable nickel-cadmium batteries.
5. When charging for the first time or after a long time, playing time may be reduced. In this case, charge and discharge the batteries several times.

4

LISTENING WITH HEADPHONES

Connect the plug of the stereo headphones into the PHONES (GREEN) socket.

Caution: Avoid excessive volume levels and listening to sound for a long period of time when using headphones.

- Adjust Volume to the desired level.

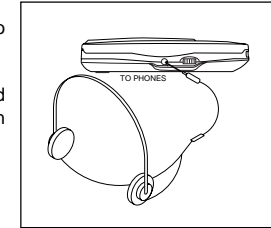

HANDLING COMPACT DISCS

This unit is designed to play only compact disc bearing the identification logo below. Other disc may not conform to the CD standard and may not play properly.



- Dirty, scratched or warped disc may cause skipping or noise.
- Handle the disc only by the edges. To keep clean, do not touch its surface.
- Discs should be stored in their cases after use to avoid serious scratches.
- Do not expose disc to direct sunlight, high humidity, high temperatures or dust etc. Prolonged exposure to extreme temperatures can warp the disc.
- Do not stick or write anything on either side of disc. Sharp writing instruments, or the inks used in some felttip pens, may damage its surface.

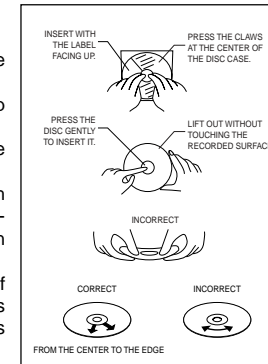

Remove the disc

Hold the edge and gently press the centre pivot as illustrated, to pick up the disc.

CAUTION:

Wait for the disc to stop rotating before pressing the OPEN button.

Note: This unit can play 3" (8cm) single CD's without an adaptor. Do not use a CD single adaptor for these discs.

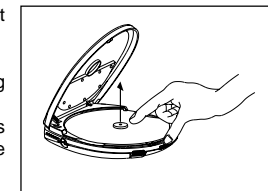

5

CLEANING DISCS

- Finger prints should be carefully wiped from the surface of disc with a soft cloth. Unlike conventional records, compact discs have no grooves to collect dust and microscopic debris, so gently wiping them with a soft cloth should remove most particles. Wipe in a straight motion from the center to the edge.
- Never use thinner, benzene, record cleaner or anti-static spray on a compact disc. Such chemicals can damage its plastic surface.

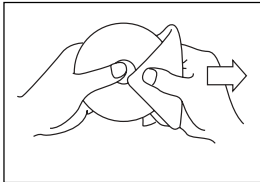

BASIC DISC PLAY

This CD-player can play Audio Discs such as CD-Recordables and CD-Rewritables. Do not try to play a CD-ROM, CDi, VCD, DVD or computer CD.

1. Connect the headphones to the PHONES (GREEN) socket.
2. Press the OPEN button to open the CD compartment lid.
3. Adjust the VOLUME to minimum.
4. Insert the disc with the label side facing up.
5. Close the lid securely until a click is heard.
6. Press the PLAY button to start playing.

To Emphasize the bass sound

Set the BASS BOOST switch to the ON position.

Note: The bass boost performance will be dependant on the VOLUME control setting.

BASS BOOST

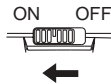

HOLD Switch

This switch prevents accidental selection of an unwanted function during Playback or Stop mode. In the HOLD "ON" position, no function button on the unit can operated (except OPEN). Moving the switch to the "OFF" position, the unit returns to normal operation.

Turning Power on and off

This unit has no ON/OFF switch. To turn on and off, press the following buttons.

To turn on: Press >|| PLAY/PAUSE (playback starts).

To turn off: Press ■ STOP button once to standby mode.

If press ■ STOP button twice, it will be turn off the power immediately.

Auto power-off function

When the unit is stopped (standby mode) for approximately 30 seconds, the power is automatically turned off.

LCD DISPLAY INFORMATION

WHEN POWER ON

- If disc is in, starts auto adjustment. During adjustment, display shows --.
- If no disc, then **disc** is displayed. Put the disc and close the lid, then starts auto adjustment again.
- If the lid is opened, display shows **OPEN**. Closing the lid starts auto adjustment.
- If can't read TOC then **Er** is displayed. Note: TOC means Table Of Contents.
- When TOC data has been read, display shows TOC 1 second.
- Starts play from track No. 1 automatically. **ANTI-SHOCK** starts flashing.

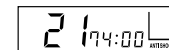
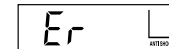
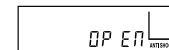
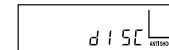
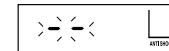

TO PLAY FROM STOP CONDITION

- Press PLAY/PAUSE button, then display changes to **01 00:00** and starts play.
- When the memory full condition, **ANTI-SHOCK** stops flashing.

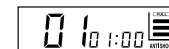

TO STOP

Press STOP key, then stops play and TOC is displayed.

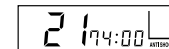

TO PAUSE

Press PLAY/PAUSE button, then pause on/off alternately. On pause condition, time display is flashing.

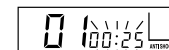

REPEAT/PLAY MODES

Every time the MODE button is pressed.
The corresponding mode appears in the display window.

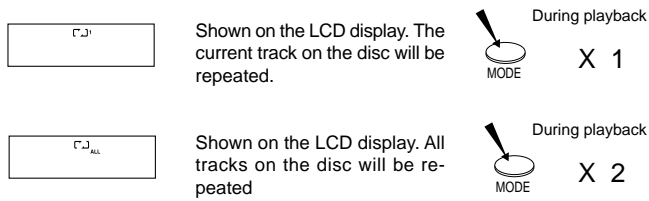
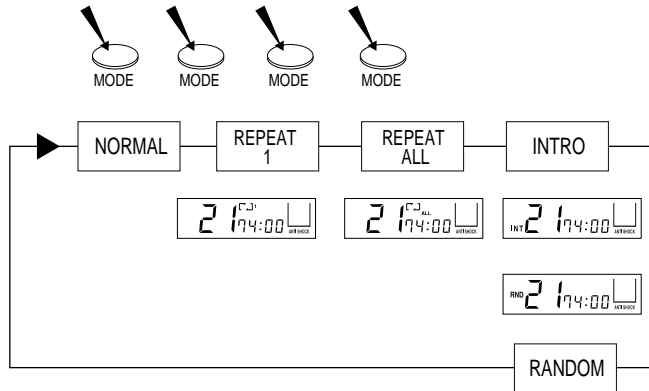

NOTE: In normal mode none of the above symbols show in the display.

NORMAL PLAYBACK

Press ANTI-SHOCK key, then disappear.

A indicator appears on the display when the batteries need to be changed.

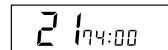

8

INTRO PLAY

1. Press MODE button three times, then **INT** is displayed.

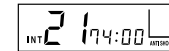

2. Press PLAY / PAUSE button, and starts INTRO play from track no. 01.



3. Select INTRO mode during play, **INT** starts flash.



- Press PLAY/PAUSE button, then stops flash and starts INTRO play from track no. 01.
- Press >>I or after finish to play the current track, stops flash and starts INTRO play from next track.
- Press I<<, then stops flash and starts INTRO play from current track.

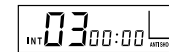
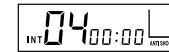

PROGRAM PLAY

This allows selected tracks on the disc to be played in any desired order.

To set the program play

- Programmes can be set in the STOP mode or normal play mode.

1. Press the PROG button, then **PRG** and starts flash.
2. Press I<< or >>I to select the desired track.
3. When desired track is displayed, press PROG button to register. Then track No. display change to 00 again.
4. Repeat step 2 and 3 to program the order of more tracks up to 20 tracks can be programmed into memory.

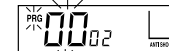
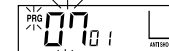
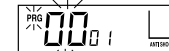

To complete programming and start play

Press PLAY/PAUSE button, then **PRG** stops flash and starts play soon.

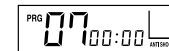

To clear programming

- Register 00 on the first program track.
- Open the door.
- Power Off

9

RANDOM PLAY

Enables all the tracks on a disc to be played in a Random (Shuffle) sequence.

1. Press MODE button four times, then RND is displayed.

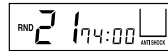

2. Press PLAY/PAUSE button, then the track No. is selected at random and starts play.

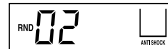

3. Select RANDOM mode during play, RND starts flash.

- Press PLAY/PAUSE button or I<< or >>I, stops flash and starts RANDOM play.
- After finish to play the current track, stops flash and starts RANDOM play.



SKIP AND SEARCH FUNCTION

Locating a Particular track

To go back to the beginning of the current or a previous track	Press I<< lightly and repeatedly.
To go to the beginning of following tracks	Press >>I lightly and repeatedly.

Locating a Particular Point in a track

To search backwards at high speed	Keep I<< depressed
To search forward at high speed	Keep >>I depressed

Low level audio will be heard during the search process to assist in locating the correct point in the track.

MAINTENANCE

Cleaning the Cabinet

Wipe with a soft cloth. If the cabinet is very dirty, dampen the cloth with a weak solution of neutral detergent and water, and then wipe clean.

Cleaning the Lens

A dirty lens will cause sound skipping and, if the lens is very dirty, the CD may not work. Open the disc cover and clean the lens as below.

- Dust or Dry Particles

Using a camera lens brush/blower, blow on the lens couple times, then wipe it lightly with the brush to remove dust. Then, blow on the lens once more.

- Fingerprints

If the lens cannot be cleaned by using a brush/blower, use a dry cotton swab starting in the middle and working to the outside edge.

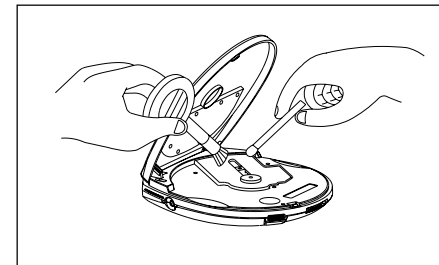

USING ANTI-SHOCK AND SKIP FREE PROTECTION FEATURE

Note the "□" indicator appears on display as being empty when the player first activated. It immediately begins to store sound data in memory bank, the indicator appears to be "▣" when the data buffer is full.

When the laser loses tracking due to mechanical shock, the data stream into the memory is interrupted but the data output from the memory buffer continues, so the sound is not interrupted. As the data is read from the memory, the indicator changes from "▣" to "▢".

Once the laser locks again on the CD track, the data stream is fed to the memory and joined to the previous data (see indicator changes) at higher speed, this provides higher level shock protection than the traditional one.

CAUTION

If the unit is subject to excessive and continuous repeated shocks than expected, it will cause sound skip. Also note the "□" indicator will appear empty.

NOTES

- When the "ANTI-SHOCK" is operating, the battery consumption is higher because the disc rotates faster than normal and also the memory circuitry is activated.
- When the digital anti-skip function is switched "ON" or "OFF", the sound will be interrupted, and it is normal.
- Remember that condition such as dirty, scratched or warped discs may cause skipping or noise thereby affecting performance of "ANTI-SHOCK" system.

PRODUCT SPECIFICATIONS

PICK UP

System	Compact disc digital audio system
Laser diode	Material : GaAlAs
Properties	Wavelength: \approx 780nm Emission duration : continuous Laser output: < 44.6 μ W
Error correction	Cross-interleave Reed-solomon code

AUDIO

D/A conversion	DAC four times oversampling
Frequency response	20-20,000Hz (+1/-3 dB)
Wow and filter	Below measurable limits
No. of channels	2 Channel (stereo)
Output level	Headphones : 20mW (32K)
Bass boost effect (100Hz)	+8 dB

GENERAL

Power requirements	- 2 x LR6 "AA" alkaline battery - DC in 6V jack accepts AC power adaptor (centre positive)
Power consumption	0.8W (DC 3V) under normal condition
Dimension	Approx. 128 (W) x 28.5 (H) x 137 (D) mm
Weight	Approx. 200g not including battery

Free Manuals Download Website

<http://myh66.com>

<http://usermanuals.us>

<http://www.somanuals.com>

<http://www.4manuals.cc>

<http://www.manual-lib.com>

<http://www.404manual.com>

<http://www.luxmanual.com>

<http://aubethermostatmanual.com>

Golf course search by state

<http://golfingnear.com>

Email search by domain

<http://emailbydomain.com>

Auto manuals search

<http://auto.somanuals.com>

TV manuals search

<http://tv.somanuals.com>