

Kawasaki™

1 GALLON AIR COMPRESSOR 2 PEAK HP INSTRUCTION MANUAL



THIS MANUAL CONTAINS IMPORTANT INFORMATION REGARDING SAFETY, OPERATION, MAINTENANCE AND STORAGE OF THIS PRODUCT. BEFORE USE, READ CAREFULLY AND UNDERSTAND ALL CAUTIONS, WARNINGS, INSTRUCTIONS AND PRODUCT LABELS. FAILURE TO DO SO COULD RESULT IN SERIOUS PERSONAL INJURY AND/OR PROPERTY DAMAGE.

IF YOU SHOULD HAVE ANY QUESTIONS OR EXPERIENCE A PROBLEM WITH YOUR ALLTRADE PRODUCT, DO NOT RETURN THIS PRODUCT TO THE STORE. PLEASE CALL OUR CUSTOMER SERVICE DEPARTMENT AT **1-800-590-3723**. BEFORE YOU CALL, HAVE THE FOLLOWING INFORMATION AVAILABLE: MODEL No., DATE PURCHASED AND STORE LOCATION. AN ALLTRADE REPRESENTATIVE CAN RESOLVE YOUR PROBLEM OVER THE PHONE. IF YOU WOULD LIKE TO MAKE A SUGGESTION OR COMMENT, GIVE US A CALL OR EMAIL US AT: INFO@ALLTRADETOOLS.COM. YOUR FEEDBACK IS VITAL TO US.

**FOR CUSTOMER SERVICE
POUR LE SERVICE APRÈS VENTE
OU DU CONSOMMATEUR**

**PARA EL SERVICIO
PARA EL CONSUMIDOR**

1-800-590-3723

Printed in China



87-1904-60957

KAWASAKI™ IS A TRADEMARK LICENSED BY KAWASAKI™ MOTORS CORP., U.S.A., WHICH DOES NOT MANUFACTURE OR DISTRIBUTE THIS PRODUCT. CONSUMER INQUIRES SHOULD BE DIRECTED TO:

©COPYRIGHT 2007 ALLTRADE TOOLS, LLC.
1431 VIA PLATA
LONG BEACH, CA 90810-1462 USA
840700 - Twin Tank Air Compressor_Rev 6/20/07

TABLE OF CONTENTS

SPECIFICATIONS	1-2
INTRODUCTION	2
SAFETY ALERT	2
RECOGNIZE SAFETY SYMBOLS, WORDS AND LABELS	3
UNPACKING & INSPECTION	3-4
SAFETY WARNINGS	4-8
GENERAL SAFETY WARNINGS	4-8
INSTALLATION AND LOCATION	8-9
GROUNDING INSTRUCTIONS	9-10
EXTENSION CORDS	10-11
COMPRESSOR FEATURES	12-14
OPERATING THE AIR COMPRESSOR	14-15
MAINTENANCE AND CLEANING	16-17
TROUBLESHOOTING GUIDE	18-20
PARTS LIST	21-23
PARTS DIAGRAM	24-25
LIMITED WARRANTY	25-28

CONGRATULATIONS!

Thanks for choosing this product. At Alltrade, our aim is to provide you with quality products at an affordable price, and we want you to be totally satisfied with your product and our Customer Service. If any help and advice is needed, please contact us at 1-800-590-3723. Properly cared for, this product will give you many years of satisfaction.

SPECIFICATIONS

SPECIFICATIONS

Two Pole Induction Motor	3500 RPM
Power	115V, 60 Hz, 15 Amps
Air Delivery	5.1 SCFM output @ 40 PSI 4.1 SCFM output @ 90 PSI
Maximum Pressure	125 PSI
Duty Cycle	75%
2.0 Peak HP / 1.1 Running HP	

SPECIFICATIONS

1 Gallon Air Tank
Oil Free Direct Drive Pump
Thermal Overload Protection for Safety
High Flow Regulator for Precision Air Flow Control
Tank and Outlet Pressure Gauges

DUTY CYCLE:

This air compressor pump is capable of running continuously. However, in order to prolong the life of your air compressor, it is recommended that a 50% to 75% average duty cycle be maintained. Duty cycle refers to the percentage of time a compressor can safely run within a given amount of time expressed as a ratio. Example: Oil lubricated compressors are typically rated at a 50% duty cycle, meaning that the compressor motor can run about 50% of the total time it is being used to supply air to a tool. During the ON time, the motor is running to pressurize the tank. During the OFF time, the motor is stopped and the tools are running off on the pressurized air stored in the tank. If your air tools are draining pressure off of the tank too quickly, the compressor motor must run more than 50% of the time the compressor is in use. This can lead to overheating and will significantly shorten the life of the compressor.

INTRODUCTION

This air compressor is designed for Household Use Only and is not intended for commercial applications. It is well suited for do-it-yourselfers with a variety of automotive and home uses.

This instruction manual is intended for your benefit. Please read and follow the safety, installation, maintenance and troubleshooting steps described within to ensure your safety and satisfaction. The contents of this instruction manual are based upon the latest product information available at the time of publication. The manufacturer reserves the right to make product changes at any time without notice.

SAFETY ALERT

⚠ WARNING Read and understand this entire instruction manual before attempting to assemble, install, operate or maintain this air compressor. Failure to comply with the instructions may result in serious personal injury and/or property damage!

SAVE THESE INSTRUCTIONS FOR FUTURE REFERENCE.

RECOGNIZE SAFETY SYMBOLS, WORDS AND LABELS

The safety instructions provided in this manual are not intended to cover all possible conditions and practices that may occur when operating, maintaining and cleaning power equipment.

Always use common sense and pay particular attention to all the **DANGER**, **WARNING**, **CAUTION** and **NOTE** statements of this manual.



This is the safety alert symbol. It is used to alert you to potential personal injury hazards. Obey all safety messages that follow this symbol to avoid possible injury or death.

DANGER

DANGER indicates an imminently hazardous situation which, if not avoided, will result in death or serious injury.

WARNING

WARNING indicates a potentially hazardous situation which, if not avoided, could result in death or serious injury.

CAUTION

CAUTION indicates a potentially hazardous situation which, if not avoided, may result in minor or moderate injury.

CAUTION

CAUTION used without the safety alert symbol indicates a potentially hazardous situation which, if not avoided, may result in property damage.

NOTE

NOTE provides additional information that is useful for proper use and maintenance of this tool. If a **NOTE** is indicated make sure it is fully understood.

UNPACKING & INSPECTION

After opening the carton, unpack your new air compressor and related parts & accessories. Please inspect it carefully for any damage that may have occurred during transit. Please check it against the photograph on carton. If any parts are missing, please contact our Consumer Helpline: Phone: 1-800-590-3723 E-Mail: info@alltradetools.com

WARNING

Do not operate this air compressor if damaged during shipment, handling or misuse. Damage may result in bursting, which can cause serious injury or property damage. All damaged parts must be repaired or replaced as needed prior to operating this air compressor.

Check to see that all nuts, bolts and fittings are secure before putting this air compressor into service. If you have any questions, or require assistance with damaged or missing parts, please contact our Consumer Helpline:

Phone: 1-800-590-3727

E-Mail: info@alltradetools.com

Please have the serial number, model number, date of purchase, and parts list (with missing parts identified) available for reference when calling.

MODEL NUMBER: _____

SERIAL NUMBER: _____

DATE OF PURCHASE: _____

SAFETY WARNINGS

READ ALL SAFETY WARNINGS BEFORE USING AIR COMPRESSOR.

GENERAL SAFETY WARNINGS

WARNING

Keep work area clean. Messy areas and cluttered workbenches invite personal injury and/or property damage.

Keep children and visitors away. All children should be kept away from the work area. **DO NOT** let children handle the compressor or extension cord. Maintain a safe distance for any person near the work area.

Operating any tools or equipment under the influence of drugs, alcohol, or medication can cause personal injury to yourself and others.

Wear proper apparel. Remove your jewelry before using air compressor. Do not wear loose clothing, necklaces, rings, bracelets, or other jewelry, which may get caught in moving parts. Nonskid footwear and electrically non-conductive gloves are highly suggested while working. Wear protective hair covering to contain long hair.

Protect your eyes. The operation of any air compressor can result in foreign objects being thrown into the eyes, which can result in severe eye damage. Always wear eye protection that meets ANSI Z28.1 specifications during air compressor operation. Eyeglasses are not always safety glasses.

⚠ WARNING

Be responsible for your hearing. Wear hearing protection during extended periods of operation.

Use the right tool. Use tools properly and for their intended task. Do not force a small tool to do the job of a heavy-duty tool. Using the right tool to do the right job will make doing the job safer.

Check damaged parts before use of any air tools or attachments. A guard or other part that is damaged should be carefully checked to ensure that it will operate properly and perform its intended function. Check for misalignment or binding of moving parts, breakage of parts, mounting, or any other conditions that may affect tool operation. A guard or other part that is damaged should be properly replaced. See replacement parts list for additional details.

Avoid unintentional starting. Be sure that your air compressor is in the OFF position before plugging it into a power cord or electrical receptacle.

Store all maintenance tools away from the immediate area before turning ON your air compressor.

Do not overreach. Proper footing and balance is a must at all times while using tools. Unstable support may lead to personal injury. Do not stand on the tool. Serious injury could result if the tool tips over or you accidentally contact tool.

Never leave the air compressor running unattended. Always turn the power to the OFF position and do not leave the air compressor until it comes to a complete stop.

When using air accessories, consult the owner's manual provided by the manufacturer. The use of improper accessories may cause risk of injury to yourself and others.

Always make sure the tool is in the OFF position and unplugged from the electrical receptacle when making adjustments, changing parts, or performing any maintenance.

Secure work. When possible, the use of clamps or a holding device is much safer than holding the work piece with your hands.

Keep protective guards in place and in proper working condition.

Maintain tools and equipment with care. They will function better and more safely when kept clean and in good working condition. Keeping the air compressor clean, dry, and free of grime will add to its life and performance.

Childproof the workshop. The use of master switches and padlocks is highly recommended. Remove starter keys where applicable.

⚠ WARNING

Some dust created by spraying, blowing, power sanding, sawing, grinding, drilling and other construction activities contains chemicals known to the State of California to cause cancer, birth defects or other reproductive harm.

Reduce your exposure to these chemicals by wearing approved safety equipment such as dust masks that are designed to filter out microscopic particles.

Use of this product will expose you to chemicals known to the State of California to cause cancer, birth defects, and reproductive harm. **AVOID INHALING VAPORS AND DUST. WASH HANDS AFTER USING.**

This product contains chemicals, including lead, known to the State of California to cause cancer, birth defects, and reproductive harm. **WASH HANDS AFTER HANDLING.**

Handling the power cord on this product may expose you to lead, a chemical known to the state of california to cause cancer and birth defects or other Reproductive harm. **WASH HANDS AFTER HANDLING.**

⚠ WARNING

DRAIN LIQUID FROM AIR TANK DAILY

- Use the drain valve located on the bottom of the lower air tank to drain. Failure to properly drain liquid from the tank will cause rust from moisture buildup, which weakens the tank and could lead to a violent tank explosion. Periodically inspect the tanks for unsafe conditions such as corrosion, cracked welds, and leaks.
- Release air slowly when draining moisture or depressurizing the air compressor. Fast moving air will stir up dust, dirt and debris that may be harmful.

RISK OF FIRE OR EXPLOSION

Avoid dangerous environments. Do not spray combustible/flammable liquid in a confined area. Spray area must be well ventilated. Do not smoke while spraying or spray where spark or flame is present. Arcing parts — keep compressor at least 20' away from spraying area and all explosive vapors. Do not use compressor near gasoline or other flammable materials. Operate the air compressor in a well-ventilated area. Do not direct paint or other spray material towards the compressor. Read and follow all safety instructions for the material you are spraying. Be sure to use an approved respirator designed for use with your specific application.

RISK OF INJURY

Do not direct air stream at body. Use eye protection. Compressor starts automatically. Do not touch MOVING PARTS. Keep guards in place. Compressor does not supply breathable air.

⚠ DANGER

RISK OF BURSTING

- Do not adjust regulator to result in output pressure greater than marked maximum pressure of attachment. If a regulator has not been installed, use only attachment rated at 200 PSI or higher. Do not weld on or repair tank — **A DAMAGED TANK MUST BE REPLACED IMMEDIATELY.** Do not operate without proper safety valve in place.
- Never attempt to repair or make modifications to the tank or its attachments. Welding, drilling, or any other modifications may weaken the tank, which may result in damage from rupture or explosion. Never remove or attempt to adjust the pressure switch, safety valve, or other components that control tank pressure. Never substitute parts or attempt to alter the factory set operating pressures.

RISK OF ELECTRICAL SHOCK

Disconnect air compressor from power source before servicing. **USE PROPERLY grounded ELECTRICAL CONNECTIONS** — do not use grounding adapters. Do not use in wet or damp locations or expose to rain. Keep all connections dry and off the ground. Do not allow power cords to come into contact with water. Do not touch the plug with wet hands. Do not pull on the electrical cord to disconnect from the power outlet. Store air compressor indoors when not in use. Any electrical wiring or repairs performed on this air compressor should be done by authorized service personnel in accordance with federal and local electrical codes.

⚠ WARNING

RISK TO BREATHING

- This air compressor is not designed, nor intended for the supply of breathable quality air. Air produced by this unit may contain carbon monoxide or other toxic vapors. Do not inhale air from the compressor or from a breathing device connected to it.
- Operate the air compressor in a well-ventilated area. Read and follow all safety instructions for the material you are spraying. Be sure to use an approved respirator designed for use with your specific application.

RISK OF BURNS

Touching exposed metal such as the compressor head or exhaust tube can result in serious burns. Keep hands and fingers away from exposed metal parts on air compressor during or immediately after operation. Air compressors generate significant heat during normal operation and will remain hot for some time after use. Do not reach around protective shrouds or attempt any maintenance until compressor has been allowed to cool.

⚠ WARNING

RISK OF FLYING OBJECTS

Do not direct compressed air stream at people or pets. The powerful compressed air stream can damage exposed skin and easily propel loose dirt and other small objects at high-speed, resulting in serious injury. Always wear eye protection that meets ANSI Z28.1 specifications. Use only OSHA approved air blowguns. Never leave a pressurized air compressor unattended. Shut OFF air compressor and relieve pressure before performing maintenance or repairs. Do not move the air compressor while the air tank is pressurized. Never attempt to move the air compressor by pulling on the air hose.

RISK OF FALLING

Portable air compressors can fall from a table, workbench, or roof causing damage to the compressor and could result in serious injury or death to the operator. Always operate air compressor in a stable and secure position to prevent accidental movement of the unit. Never operate air compressor on a roof or other elevated position. Use additional air hose to reach high locations.

AIR TOOLS AND ACCESSORIES

Do not exceed the pressure rating of any air tools, spray guns, air accessories, or inflatables. Excess pressure can cause them to explode, resulting in serious injury. Follow the manufacturers recommended pressure settings for all air tools and air accessories.

INSTALLATION AND LOCATION

⚠ CAUTION

In order to avoid damaging the air compressor, do not allow the unit to be tilted more than 10° from the normal horizontal position when operating.

The compressor must be run with the rubber feet resting on a flat and stable horizontal surface.

The air compressor must be used in a clean and well-ventilated area. The compressor requires an unobstructed airflow and must be located a minimum of 20 inches from any walls or other obstructions that may prevent proper ventilation.

⚠ CAUTION

DO NOT place air compressor in an area:

- Where there is evidence of oil or gas leaks.
- Where flammable gas vapors or materials may be present.
- Where air temperatures fall below 32°F or exceed 104°F.
- Where extremely dirty air or water could be drawn into the air compressor.

⚠ WARNING

Serious injury or death may occur if electrical sparks from motor and pressure switch come in contact with flammable vapors, combustible dust, gases or other combustible materials. When using the air compressor for spraying paint, place the air compressor as far away from the work area as possible, using extra lengths of air hose to extend the working reach instead of extension cords.

GROUNDING INSTRUCTIONS

This product should be grounded. In the event of an electrical short circuit, grounding reduces the risk of electric shock by providing an escape wire for the electric current. This product is equipped with a cord having a grounding wire with an appropriate grounding plug. The plug must be plugged into an outlet that is properly installed and grounded in accordance with all local codes and ordinances.

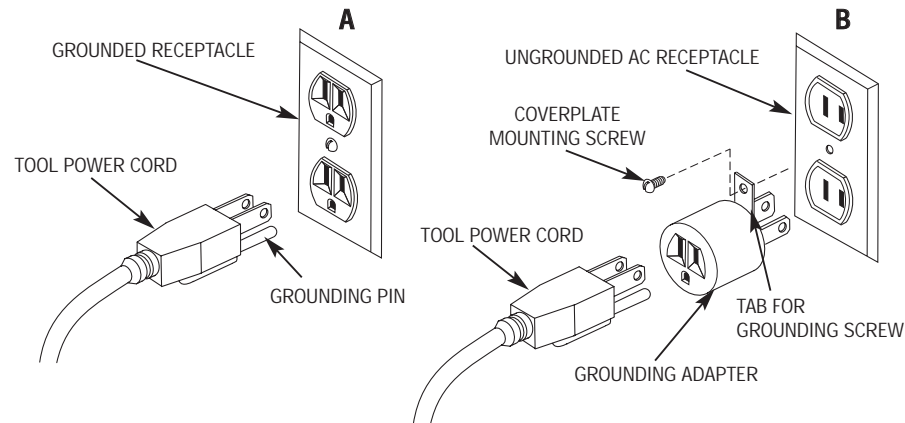

FIGURE 1. CONNECTING THE AIR COMPRESSOR TO THE AC POWER RECEPTACLE

⚠ DANGER

Improper installation of the grounding plug can result in a risk of electric shock. If repair or replacement of the cord is necessary, do not connect the grounding wire to either flat blade terminal. The wire with GREEN insulation with or without yellow stripes is the grounding wire.

This product is for use on a nominal 120-volt circuit and has a three-prong grounding plug that looks like the plug illustrated in Figure 1. A temporary adapter similar to the adapter illustrated in sketch B (See Page 9) may be used to connect this plug to a 2-pole receptacle as shown in illustration B when a properly grounded outlet is not available. The temporary adapter shall be used only until a properly grounded outlet (Illustration A) is installed by a qualified electrician. Tab for grounding screw, lug, or similar part extending from the adapter must be connected to a permanent ground such as a properly grounded outlet box cover. Whenever the adapter is used, it must be held in place by a metal screw.

The use of a GFCI outlet is strongly recommended. The third prong is to be used to ground the tool and provide protection against electrical shock. Never remove the third prong.

Check with a qualified electrician or serviceman if the grounding instructions are not completely understood, or if in doubt as to whether the product is properly grounded. Do not modify the plug provided. If it will not fit the outlet, have the proper outlet installed by a qualified electrician.

EXTENSION CORDS

⚠ CAUTION

THE USE OF AN EXTENSION CORD WITH THIS PRODUCT IS NOT RECOMMENDED as this can result in the loss of power to your air compressor which can prevent the motor from starting or running properly. This can also cause your fuse to blow or circuit breaker to trip. Running your air compressor on an undersized extension cord will cause permanent damage to internal switches and overheating of the electric motor. Use an additional length of air hose rather than an extension cord.

If you must use an extension cord, it should be plugged into a **GFCI** found in circuit boxes or protected receptacles. Use only UL listed 3-wire extension cords that have a 3-blade grounding plug and a 3-slot receptacle that will accept the plug on the product. Make sure your extension cord is in good condition. When using an extension cord, be sure to use one heavy enough to carry the current your product will draw. Refer to the guide on the next page for minimum gauge required for extension cords.

EXTENSION CORD LENGTH	WIRE SIZE (AWG)
Up to 25 Feet	14
26 to 50 Feet	12
51 to 100 Feet	Do Not Use

Use only extension cords that are intended for outdoor use. These cords are identified by a marking **“ACCEPTABLE FOR USE WITH OUTDOOR APPLIANCES, STORE INDOORS WHEN NOT IN USE.”** Examine extension cord before use. **DO NOT USE DAMAGED EXTENSION CORDS.** Do not pull on cord to disconnect from receptacle; always disconnect by pulling on plug. Keep cord away from heat and sharp edges. Always shut OFF the air compressor AUTO/ON pressure switch before unplugging the compressor. Always disconnect the extension cord from the receptacle before disconnecting the product from the extension cord.

⚠ WARNING Avoid electrical shock hazard. Never use this compressor with a damaged or frayed electrical cord or extension cord. Inspect all electrical cords regularly. Never use in or near water or in any environment where electric shock is possible. To reduce the risk of electrocution, keep all connections dry and off the ground. Do not touch the plug with wet hands.

Guard against electrical shock. Avoid body contact with grounded services such as pipes, ovens, stoves, and refrigerator enclosures. If not properly grounded, this air compressor can incur the potential hazard of light trickle shock, particularly when used in damp locations. If electrical shock occurs, there is the potential of secondary hazard such as your hands contacting an operating air tool.

COMPRESSOR FEATURES

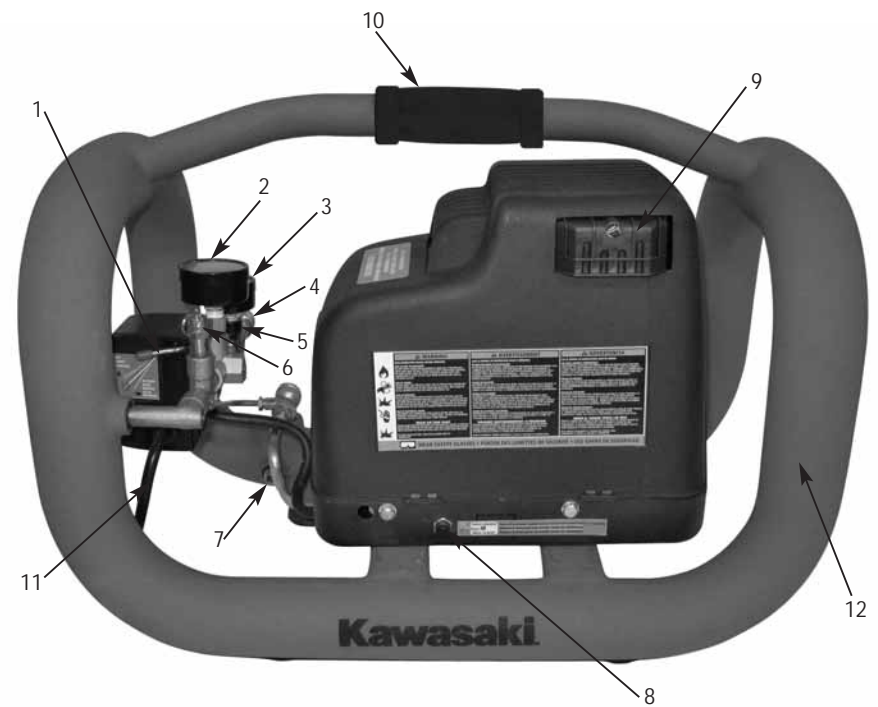

CONTROLS AND COMPONENTS:

1. Automatic On/Off Pressure Switch
2. Air Tank Pressure Gauge
3. Outlet Pressure Gauge
4. Air Coupler
5. Pressure Regulator
6. Safety Relief Valve
7. Air Tank Drain Valve
8. Manual Thermal Overload Switch
9. Air Intake Filter
10. Carry Handle
11. Power Cord
12. Frame and Air tank



COMPRESSOR FEATURES:

1. **AUTOMATIC ON/OFF PRESSURE SWITCH:** This compressor is equipped with an automatic on/off pressure switch. The compressor will only run when the switch is in the ON/AUTO position. Once the tank has reached the desired preset pressure ("cut-out" pressure), the pump motor will automatically shut off. While the switch is in the ON/AUTO position, the pump motor will automatically turn back on once the pressure in the tank drops below the minimum preset pressure ("cut-in" pressure).

⚠ WARNING Do not leave the compressor unattended while the power switch is in the on/auto position.

2. **AIR TANK PRESSURE GAUGE:** The tank pressure gauge provides a reading of the air pressure inside of the compressor tank.
3. **OUTLET PRESSURE GAUGE:** The outlet pressure gauge provides a reading of the air pressure at the outlet side of the regulator. This pressure is controlled by the pressure regulator and is always less than or equal to the air tank pressure.
4. **AIR COUPLER:** The air coupler is preinstalled into standard 1/4" NPT (F) threads in the pressure manifold. Use PTFE thread-sealing tape on the threads to make sure you have an airtight connection when replacing quick connect coupler.
5. **PRESSURE REGULATOR:** The regulator allows you to select the amount of air pressure that is output through the air hose into tools and accessories. Turn the pressure regulator knob clockwise to increase discharge pressure, and counter clockwise to decrease discharge pressure. Please refer to the air delivery requirements of your tools for the proper pressure settings.
NOTICE: Be careful not to overtighten pressure regulator knob when it "bottoms out" as this may damage pressure regulator.
6. **SAFETY RELIEF VALVE:** This compressor is equipped with a safety relief valve that is designed to prevent system failures by relieving pressure from the system when the air pressure reaches a predetermined level. The safety relief valve is preset by the manufacturer. **DO NOT** attempt to modify or remove the safety relief valve.
7. **AIR TANK DRAIN VALVE:** Moisture is produced whenever air is compressed. It is critical to drain water from the air tank on this compressor frequently. If unit is used only occasionally, tank should be drained after each use and prior to the next use. To drain the tank, slowly open the tank drain fitting by turning counter clockwise. Once all moisture has drained out, close the fitting securely. **NOTE:** Air tank will not pressurize while drain valve is open.

NOTE A dirty air filter will reduce air compressor performance and can lead to product failure.

8. **MANUAL THERMAL OVERLOAD SWITCH:** The electric motor has a manual thermal overload protector. If the motor overheats for any reason, the thermal overload protector will shut off the motor. Turn pressure switch to the "off" position and wait for unit to cool before pushing the reset button and restarting the compressor. **NOTICE:** This air compressor is designed for household use only and is not intended to operate heavy-duty air tools. If your application's demands exceed the capacity of this air compressor, a larger air compressor that is matched to your application is recommended. If the unit shuts down again, please call the consumer helpline at 1-800-590-3723 for assistance.
9. **AIR INTAKE FILTER:** This compressor is equipped with an externally accessible air intake filter that is designed to clean air coming into the pump. The filter element is easily removed for periodic cleaning. Use compressed air to blow loose dirt and debris from the paper filter element and reinstall. Replace filter element when necessary.
10. **CARRY HANDLE:** Convenient handle for easy transport.

OPERATING THE AIR COMPRESSOR

INITIAL SETUP / BREAK-IN PROCEDURE:

⚠ CAUTION Do not attach air hose, air tools or other air accessories to the air outlet until break-in procedure has been successfully completed.

1. Read and understand the entire instruction manual, including all safety warnings before setting up air compressor.
2. Place air compressor on a flat, level surface.
3. Turn the pressure regulator knob fully clockwise to open airflow from air outlet port.

NOTE Be careful not to overtighten pressure regulator knob when it "bottoms out" as this may damage pressure regulator.

4. Turn the power switch to the OFF position.
5. Plug power cord directly into a properly grounded power source of the correct voltage (see Grounding Instructions on page 5 of this instruction manual).
6. Open the tank drain valve to allow air to escape preventing air pressure buildup in the air tank.
7. Turn the compressor ON by moving the switch to the AUTO/ON position and run the air compressor for a period of 20 minutes to break-in the air pump.

8. With the compressor still running, at the end of the 20-minute break-in period, close the tank drain valve. The air compressor will build air pressure to the maximum preset pressure ("cut-out" pressure) and automatically shut off.
9. Slowly turn the tank drain valve to open airflow from drain and bleed off air from the air tank. The air compressor will automatically restart once the pressure in the air tank drops below the minimum preset pressure ("cut-in" pressure).
10. Turn the compressor off by moving the switch to the OFF position.
11. Release pressure from the system. Drain moisture from the air tank by slowly opening the air tank drain valve by turning clockwise. Tilt tank to remove all moisture. Once all the moisture has drained out, close the fitting securely.
NOTE: Air tank will not pressurize while drain valve is open.
12. Disconnect the power cord from the power outlet.
NOTE: Make sure the power switch is in the OFF position when connecting or disconnecting power cord from electrical outlet.
13. Your new air compressor is now ready to use.

STARTUP:

1. Before each startup, make sure the power switch is in the OFF position.
2. Place air compressor on a flat, level surface.
3. Release pressure from the system. Drain moisture from the air tank by slowly opening the air tank drain valve by turning clockwise. Once all the moisture has drained out, close the fitting securely. **NOTE:** Air tank will not pressurize while drain valve is open.
4. Turn the pressure regulator knob fully counterclockwise to close airflow from air outlet port.
5. Attach air hose and accessories.

⚠ WARNING Too much air pressure causes a hazardous risk of bursting.

Check the manufacturer's maximum pressure rating for air tools and accessories. The regulator outlet pressure must never exceed the maximum pressure rating.

6. Before connecting the compressor to the grounded outlet, check for broken components and accessories, and check for damage to the hose.
7. Plug power cord directly into a properly grounded power source of the correct voltage (see Grounding Instructions on page 5 of this instruction manual).
8. Turn the compressor ON by moving the switch to the AUTO/ON position and allow the tank pressure to build. Once the air pressure reaches the maximum preset pressure ("cut-out" pressure) it will automatically shut off.

9. Slowly turn the pressure regulator knob clockwise to open airflow from air outlet port until desired output pressure is reached. **NOTE:** The air compressor will automatically restart once the pressure in the air tank drops below the minimum preset pressure ("cut-in" pressure).

MAINTENANCE AND CLEANING

⚠ WARNING Disconnect AIR COMPRESSOR from power source and bleed off all air pressure before attempting any maintenance or repair.

SHUTDOWN AND STORAGE:

NOTE: NEVER stop the air compressor by unplugging it from the power outlet as this may result in damage to the compressor.

1. Turn the switch to the OFF position
2. Disconnect the power cord from the power outlet. Disconnect the power cord from the power outlet by grabbing the plug (not the cord). Loop around electric cord holder for storage.
3. Turn the pressure regulator knob fully counterclockwise to close airflow from air outlet port. Check the outlet pressure gauge to ensure that it reads 0 PSI.
4. Remove the air hose and any air accessories.
5. Drain moisture from the air tank by slowly opening the air tank drain valve by turning counter clockwise. Tilt tank to remove all moisture. Once all the moisture has drained out, close the fitting securely.
6. Allow the compressor to cool down.
7. Wipe the air compressor clean and store it in a clean, dry, and non-freezing location.

WHEN PERFORMING ANY MAINTENANCE OR SERVICE:

1. The air compressor must be turned off.
2. Disconnect compressor from the power source.
3. Open tank drain to bleed off all air pressure before attempting any maintenance or repair.
4. Allow compressor to fully cool before attempting any maintenance or repair.

Check the air compressor frequently for any visible problems and follow maintenance procedures each time the compressor is used.

MAINTENANCE CHECKLIST:

Daily:

- Drain accumulated liquid from tank.
- Check for unusual noise and/or vibrations.
- Check that all fasteners are secure.
- Wipe compressor clean.

Weekly:

- Inspect and clean air filter.

Monthly:

- Check for air leaks.+
- Check safety relief valve.

CHECKING SAFETY RELIEF VALVE:

⚠ WARNING Safety RELIEF valve must be replaced if it cannot be actuated or it leaks air after the ring is released.

1. The air compressor must be turned OFF.
2. Disconnect compressor from the power source.
3. Open tank drain to bleed off all air pressure before attempting any maintenance or repair.
4. Allow compressor to fully cool before attempting any maintenance or repair.
5. Grasp the wire ring on the safety relief valve.
6. Pull and release the ring a few times to ensure that the plunger moves in and out. Replace the safety relief valve if plunger does not move or is difficult to move.

CHECKING AIR FILTER ELEMENT:

1. The air compressor must be turned OFF.
2. Disconnect compressor from the power source.
3. Open tank drain to bleed off all air pressure before attempting any maintenance or repair.
4. Allow compressor to fully cool before attempting any maintenance or repair.
5. Remove the face of the filter body to access the filter element by removing screw holding filter in place.
6. Use compressed air to blow loose dirt and debris from the paper filter element. Replace filter element if it cannot be cleaned sufficiently.
7. Reinsert filter element into filter body and reinstall filter faceplate.

MOISTURE IN COMPRESSED AIR

Moisture is a normal by-product of compressing air. As the moisture builds during compressor use, it can be carried through the air hose. When using paint spray gun or sandblasting gun, the use of a special filter to remove moisture from the air line is highly recommended. Moisture in the compressed air will cause water spots in paint jobs and cause blasting media to clog the sandblasting gun.

TROUBLESHOOTING GUIDE

THE COMPRESSOR DOES NOT START OR RESTART:

PROBABLE CAUSE:	SOLUTION:
Power cord not plugged in.	Plug cord into grounded outlet.
Motor/Pressure switch in OFF position	Move switch to AUTO position.
Motor thermal overload switch has tripped	Turn air compressor off, wait until the motor is cool, then press motor thermal overload (red) button firmly until click is heard.
Fuse blown or circuit breaker has tripped.	Replace fuse or reset circuit breaker. Check for proper fuse amperage. Check for low voltage conditions. Disconnect any other electrical appliances from circuit or operate air compressor on its own branch circuit.
Wrong gauge wire or length of extension cord.	Check chart in instruction manual for proper gauge wire and cord length.
Air tank pressure exceeds motor/pressure switch "cut-in" pressure.	Motor will start automatically when air tank pressure drops below "cut-in" pressure of motor/pressure switch.
Pressure release valve on motor/pressure switch has not unloaded pump head pressure.	Bleed the line by moving the switch to the OFF position.
Defective motor, motor capacitor, motor/pressure switch.	Contact Consumer Helpline at 1-800-590-3723

WHEN IN THE START/STOP OPTION, MOTOR RUNS CONTINUOUSLY:

PROBABLE CAUSE:	SOLUTION:
Motor/Pressure switch does not shut off motor when air compressor reaches "cut-out" pressure and safety relief valve activates	Move the motor/pressure switch to the OFF position. If the motor does not shut off, unplug the air compressor. If the electrical contacts are welded together, replace the pressure switch.
Air compressor is incorrectly sized.	Limit the air pressure to the capacity of the air compressor. Either use a smaller tool or a larger air compressor.

AIR CONTINUES TO LEAK AT MOTOR/PRESSURE SWITCH RELEASE VALVE AFTER MOTOR STOPS:

PROBABLE CAUSE:	SOLUTION:
Defective pilot valve, the check valve is stuck open.	Remove, clean or replace.

AIR CONTINUES TO LEAK AT MOTOR/PRESSURE SWITCH RELEASE VALVE WHILE MOTOR IS RUNNING:

PROBABLE CAUSE:	SOLUTION:
Defective motor/pressure switch	Replace.
Check valve stuck in open position.	Replace check valve. DANGER – Do not disassemble the check valve with tank pressurized. Open tank petcock valve to allow air to escape from tank prior to servicing.

AIR LEAKS FROM SAFETY RELIEF VALVE:

PROBABLE CAUSE:	SOLUTION:
Possible defective safety relief valve.	Operate safety relief valve manually by pulling on ring. If it still leaks, it should be replaced.
Excessive tank pressure.	Defective motor/pressure switch. Replace.

AIR LEAKS AT FITTINGS:

PROBABLE CAUSE:	SOLUTION:
Fittings are not tight enough.	Tighten fittings where air can be heard escaping. Check fittings with soapy water solution. DO NOT OVERTIGHTEN.

AIR LEAKS IN AIR TANK:

PROBABLE CAUSE:	SOLUTION:
Defective or rusted air tank.	Air tank must be replaced. DO NOT ATTEMPT TO REPAIR AIR TANK!

AIR BLOWING FROM INLET FILTER:

PROBABLE CAUSE:	SOLUTION:
Damaged inlet (reed) valve.	Contact Consumer Helpline at 1-800-590-3723.

INSUFFICIENT PRESSURE AT AIR TOOL OR AIR ACCESSORY:

PROBABLE CAUSE:	SOLUTION:
Pressure regulator knob is not turned to high enough pressure.	Adjust pressure regulator knob to proper setting.
Defective motor/pressure regulator switch.	Replace.
Restricted air intake filter.	Clean or replace the filter element.
Air leaks.	Check for leaks by applying soap solution to all fittings and connections. Bubbles will appear at leakage points. Tighten or replace leaking fittings or connections as needed.
Hose or hose connections are too small or long.	Replace with larger hose or connectors.
Air compressor is not large enough for air requirement.	Check the accessory air requirement. If it is higher than the CFM or pressure supply of the air compressor, you need a larger air compressor.

MOISTURE IN DISCHARGE AIR:

PROBABLE CAUSE:	SOLUTION:
Condensation in air tank caused by high level of atmospheric humidity or air compressor is not running long enough.	Drain tank after every use. Drain air tank more often in humid weather and use an air line filter.

PARTS LIST

NO.	PART NO.	DESCRIPTION	QTY
1	691292-1	Centrifugal Fan	1
2	691292-2	Bolt, M6X16	1
3	691292-3	Washer	6
4	691292-4	Spring Washer	1
5	691292-5	Ball Bearing, 6203	1
6	691292-6	Connected Rod	1
7	691292-7	Bolt, M5X20	1
8	691292-8	Washer, M5	1
9	691292-9	Spring Washer, M5	1
10	691292-10	Crank	1
11	691292-11	Crank case	1
12	691292-12	Motor Cover, Bottom	1
13	691292-13	Bolt, M5X16	2
14	691292-14	Washer, M5	2
15	691292-15	Spring Washer, M5	2
16	691292-16	Hexagon Bolt, M6X16	4
17	691292-17	Motor Stator	1
18	691292-18	Bolt, M4X8	1
19	691292-19	Lock Washer, M4	1
20	691292-20	Ball Bearing, 6204	1
21	691292-21	Motor Rotor	1
22	691292-22	Ball Bearing, 6202	1
23	691292-23	Rear Cover	1
24	691292-24	Hexagon Bolt, M5X90	4

PARTS LIST

NO.	PART NO.	DESCRIPTION	QTY
25	691292-25	Spring Washer	4
26	691292-26	Capacitor Support	1
27	691292-27	Capacitor	1
28	691292-28	Bolt, M3X6	2
29	691292-29	Washer, M3	2
30	691292-30	Spring Washer, M3	2
31	691292-31	Hexagon Nut, M8	1
32	691292-32	Lock Washer, M8	1
33	691292-33	Bolt, M5X12	1
34	691292-34	Washer, M5	1
35	691292-35	Spring Washer, M5	1
36	691292-36	Motor Cover, top	1
37	691292-37	Hexagon Bolt, M6X80	4
38	691292-38	Washer, M6	4
39	691292-39	Spring Washer, M6	4
40	691292-40	Cylinder Head	1
41	691292-41	Elbow, 3/8-16X1.5	1
42	691292-42	Valve Gasket, top	1
43	691292-43	Valve Plate	1
44	691292-44	Valve Gasket, middle	1
45	691292-45	Valve Disc	1
46	691292-46	Valve Gasket, bottom	1
47	691292-47	Cylinder	1
48	691292-48	Piston Cover	1

PARTS LIST

NO.	PART NO.	DESCRIPTION	QTY
49	691292-49	Bolt, M6X16	1
50	691292-50	Piston Ring	1
51	691292-51	Rider Ring	1
52	691292-52	Connector, R1/4	1
53	691292-53	Check Valve, R3/8	1
54	691292-54	Coupler	1
55	691292-55	Regulator	1
56	691292-56	Pressure Gauge, 40	1
57	691292-57	Pressure Gauge, 50	1
58	691292-58	Safety Valve	1
59	691292-59	Elbow	1
60	691292-60	Drain Valve	1
61	691292-61	Tank	1
62	691292-62	Rubber Feet	1
63	691292-63	Washer, M5	4
64	691292-64	Bolt, M5X12	4
65	691292-65	Handle Grip	1
66	691292-66	Circuit Breaker	1

PARTS DIAGRAM

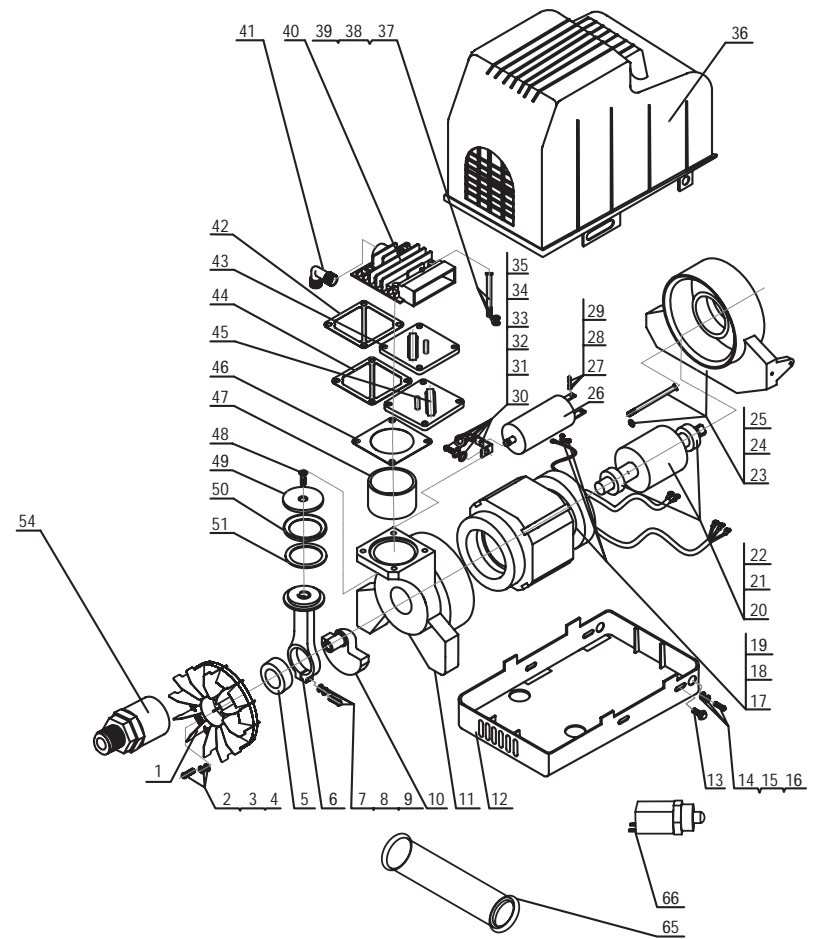

PARTS DIAGRAM

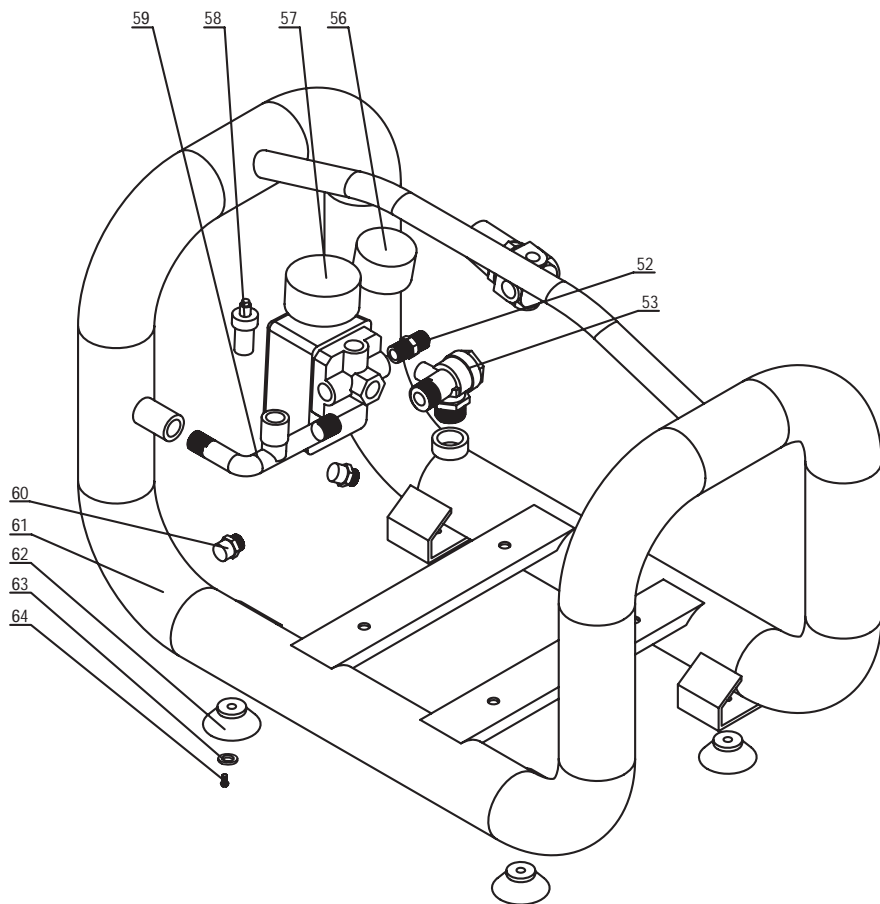

1 YEAR LIMITED WARRANTY

ALLTRADE TOOLS LLC AIR COMPRESSORS

Express and Exclusive Limited Warranty to Original Retail Buyer

Alltrade Tools LLC (hereinafter "Alltrade") expressly warrants to the original retail purchaser of the accompanying air compressor and no one else all parts of the product (except those parts referred to below which are specifically excluded from such warranty (see Exclusions)) to be free from defects in materials and workmanship during the following periods from the original date of purchase:

For one (1) year from the date of purchase:

- Compressor Pump
- Tank assembly
- Plumbing

For six (6) months from date of original purchase:

- Pressure Switch
- Regulator
- Pilot Valve
- Check Valve
- Copper/Stainless Steel Line

For ninety (90) days from the original date of purchase:

- Pressure Gauge
- Safety Release Valves
- Drain Valve
- Quick Couplers

For thirty (30) days from the original date of purchase:

- Air Accessories

The date of purchase shall be the date of shipment to the original purchaser, or the date the original purchaser took possession, custody or control of the product, whichever occurred first. This warranty shall be null and void if the product or any component thereof is modified or altered. This warranty does not apply to any other product and/or component thereof manufactured or distributed by Alltrade, and does not apply to products and/or components thereof designed, manufactured and/or assembled by others, for which Alltrade makes no warranties whatsoever.

THERE ARE NO WARRANTIES WHICH EXTEND BEYOND THE DESCRIPTION ON THE FACE HEREOF.

Warranty Performance

By purchasing the product, purchaser expressly acknowledges and agrees that their sole and exclusive remedy under this warranty shall be strictly limited to the repair or replacement of any covered nonconforming items or parts thereof provided that any such nonconforming item and/or part is promptly returned to Alltrade's facility postage pre-paid and insured (ADDRESS: ALLTRADE Warranty Claims & Repair, 1431 Via Plata, Long Beach, CA 90810, Attn: Customer Service (TELEPHONE: 1-800-590-3723.) within the applicable warranty period, with a written request by purchaser that Alltrade repair and/or replace the nonconforming item and/or part. We recommend that you keep the original product packaging in the event you need to ship the unit. We suggest the package be insured against loss or in transit damage. When sending your product include your name, address, phone number, dated proof of purchase (or copy), and a statement about the nature of problem. Warranty coverage is conditioned upon purchaser furnishing Alltrade with adequate written proof that they are the original purchaser and of the original purchase date. Parts returned, freight prepaid and insured, to Alltrade's facility (see above address) will be inspected and, at Alltrade's option, repaired and/or replaced free of charge if found to be defective and subject to warranty. Alltrade retains the sole discretion to determine whether any item or part is nonconforming and, if so, whether the item and/or part will be repaired and/or replaced. If Alltrade chooses to replace the product, it may replace it with a new or reconditioned one of the same or comparable design. The repaired or replaced unit will be warranted under the terms of the remainder of applicable warranty period(s). Typically, covered defective parts not subject to normal wear and tear or other exclusions will be repaired or replaced, at Alltrade's option, during the above stated warranty periods. Alltrade's repair and/or

replacement of any nonconforming item and/or part thereof shall constitute fulfillment of all obligations to the purchaser. Alltrade shall not be responsible or liable for any expense, including freight charges, or repairs made outside Alltrade's facility, unless expressly agreed to by Alltrade in writing. Under no circumstances shall Alltrade bear any responsibility for loss of the unit, loss of time or rental, inconvenience, commercial loss or consequential damages.

Exclusions

This warranty does not cover parts damaged due to normal wear, abnormal conditions, misapplication, misuse, abuse, accidents, operation at other than recommended pressures or temperatures, improper storage or freight damage. Parts damaged or worn by operation in dusty environments are not warranted. Failure to follow recommended operating and maintenance procedures also voids warranty.

The following additional items are not covered under this warranty: pump or valve failure caused by rain, excessive humidity, corrosive environments or other contaminants; cosmetic defects that do not interfere with compressor functionality; and rusted tanks, including but not limited to rust due to improper drainage or corrosive environments.

This warranty shall not apply when: the air compressor has been used for commercial or rental purposes; defects in materials or workmanship or damages result from repairs or alterations which have been made or attempted by others or the unauthorized use of nonconforming parts; damage is due to abuse (including overloading of the air compressor beyond capacity), improper maintenance, neglect or accident, or the damage is due to use of the air compressor after partial failure or use with improper accessories.

Alltrade will not be liable for the following: labor charges, loss or damage resulting from improper operation, maintenance or repairs made by other persons; pre-delivery services such as assembly, oil or lubricants, and adjustment; maintenance services that are normally required to maintain the air compressor.

The use of other than genuine Alltrade Repair Parts will void warranty.

Warranty Disclaimers

EXCLUSION AND DISCLAIMER OF ALL OTHER EXPRESS WARRANTIES, GUARANTIES AND/OR REPRESENTATIONS. EXCEPT FOR THE LIMITED WARRANTY PROVIDED ABOVE, ALL OTHER EXPRESS WARRANTIES, GUARANTIES AND/OR REPRESENTATIONS BY ALLTRADE AND/OR ITS REPRESENTATIVE(S) REGARDING THE DESIGN, MANUFACTURE, PURCHASE, USE AND/OR OPERATION OF THE AIR COMPRESSOR OR ANY COMPONENT THEREOF SOLD HEREUNDER, REGARDLESS OF WHETHER ANY SUCH WARRANTY, GUARANTY AND/OR REPRESENTATION, WRITTEN OR ORAL, ARISES BY OPERATION OF LAW AND/OR EQUITY AND/OR BY ANY ACT OR OMISSION OF ALLTRADE AND/OR ITS REPRESENTATIVE(S), OR THE BUYER, ARE HEREBY EXPRESSLY EXCLUDED AND DISCLAIMED BY ALLTRADE AND/OR ITS REPRESENTATIVES. PURCHASER KNOWINGLY AND WILLINGLY WAIVES ANY AND ALL SUCH WARRANTIES AND RIGHTS, CLAIMS AND/OR CAUSES OF ACTION ARISING THEREFROM OR BASED THEREON. PUR-

CHASER'S SOLE AND EXCLUSIVE REMEDY IS AS STATED ABOVE.

EXCLUSION AND DISCLAIMER OF ALL IMPLIED WARRANTIES, INCLUDING THE IMPLIED WARRANTIES OF MERCHANTABILITY AND FITNESS FOR A PARTICULAR PURPOSE. NO WARRANTY, ORAL OR WRITTEN, OTHER THAN THE ABOVE WARRANTY IS MADE WITH REGARD TO THIS AIR COMPRESSOR. ALL EXPRESS AND/OR IMPLIED WARRANTIES, GUARANTIES AND/OR REPRESENTATIONS BY ALLTRADE AND/OR ITS REPRESENTATIVE(S) REGARDING THE DESIGN, MANUFACTURE, PURCHASE, USE AND/OR OPERATION OF THE AIR COMPRESSOR OR ANY COMPONENT THEREOF SOLD HEREUNDER, REGARDLESS OF WHETHER ANY SUCH WARRANTY, GUARANTY AND/OR REPRESENTATION, WRITTEN OR ORAL, ARISES BY OPERATION OF LAW AND/OR EQUITY AND/OR BY ANY ACT OR OMISSION OF ALLTRADE AND/OR ITS REPRESENTATIVE(S), OR THE PURCHASER, INCLUDING BUT NOT LIMITED TO THE IMPLIED WARRANTY OF MERCHANTABILITY AND THE WARRANTY OF FITNESS FOR A PARTICULAR PURPOSE, ARE HEREBY EXPRESSLY EXCLUDED AND DISCLAIMED BY ALLTRADE AND/OR ITS REPRESENTATIVES. PURCHASER KNOWINGLY AND WILLINGLY WAIVES ANY AND ALL SUCH WARRANTIES AND RIGHTS, CLAIMS AND/OR CAUSES OF ACTION ARISING THEREFROM OR BASED THEREON.

PURCHASER'S SOLE AND EXCLUSIVE REMEDY IS AS STATED ABOVE.

Limitation Of Liability

IN NO EVENT SHALL ALLTRADE AND/OR ITS REPRESENTATIVE(S) BE LIABLE FOR INDIRECT, INCIDENTAL, SPECIAL AND/OR CONSEQUENTIAL DAMAGES OF ANY KIND ARISING OUT OF OR RELATED TO, DIRECTLY OR INDIRECTLY, ANY BREACH OF ANY PROVISION OF ANY AGREEMENT BETWEEN ALLTRADE AND/OR ITS REPRESENTATIVE(S) AND PURCHASER, ANY WARRANTY HEREUNDER, AND/OR THE EXISTENCE, DESIGN, MANUFACTURE, PURCHASE, USE AND/OR OPERATION OF ANY ITEM(S) SOLD HEREUNDER EVEN IF ALLTRADE AND/OR ITS REPRESENTATIVE(S) HAS BEEN ADVISED OF THE POSSIBILITY OF ANY SUCH DAMAGES. IN NO EVENT, WHETHER AS A RESULT OF A BREACH OF CONTRACT, WARRANTY, TORT (INCLUDING NEGLIGENCE) OR OTHERWISE, SHALL ALLTRADE'S AND/OR ITS REPRESENTATIVE(S)' LIABILITY EXCEED THE PRICE OF THE AIR COMPRESSOR. ANY AND ALL LIABILITY CONNECTED WITH THE USE OF THIS AIR COMPRESSOR SHALL TERMINATE UPON THE EXPIRATION OF THE WARRANTY PERIODS SPECIFIED ABOVE.

Limitations on Warranty Disclaimers

Some states do not allow limitations on how long an implied warranty lasts and some states do not allow the exclusion or limitation of the incidental or consequential damages, so part or all of the above limitations or exclusions may not apply to you. This warranty gives you specific legal rights, and you may also have other rights which vary from state to state.

If your product is not covered by this warranty, please call our Customer Service Department at 1-800-590-3727 for general repair information and charges.

Free Manuals Download Website

<http://myh66.com>

<http://usermanuals.us>

<http://www.somanuals.com>

<http://www.4manuals.cc>

<http://www.manual-lib.com>

<http://www.404manual.com>

<http://www.luxmanual.com>

<http://aubethermostatmanual.com>

Golf course search by state

<http://golfingnear.com>

Email search by domain

<http://emailbydomain.com>

Auto manuals search

<http://auto.somanuals.com>

TV manuals search

<http://tv.somanuals.com>