

Kawasaki™

14" CUT-OFF SAW

INSTRUCTION MANUAL

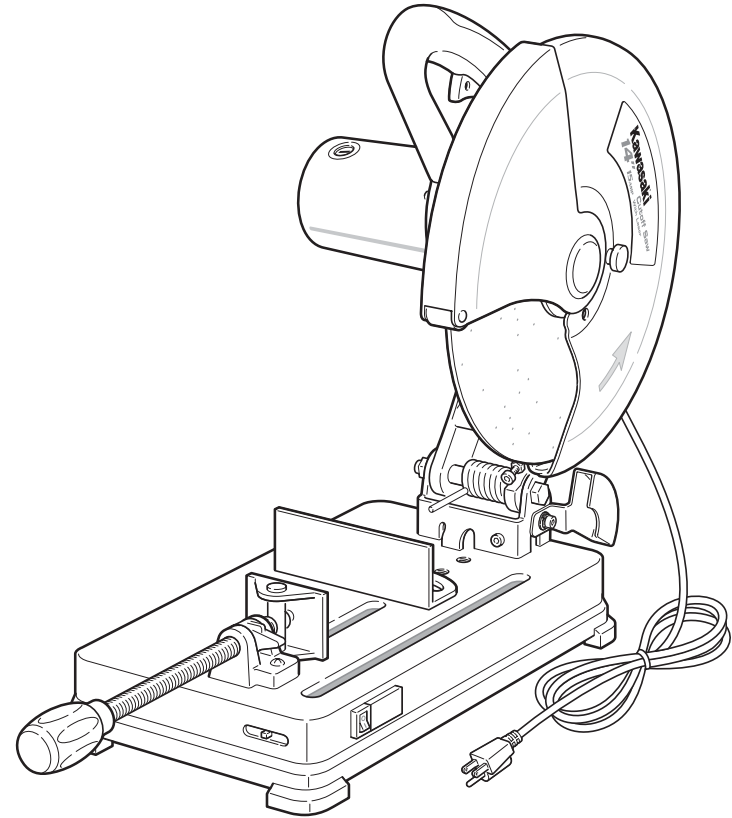

THIS MANUAL CONTAINS IMPORTANT INFORMATION REGARDING SAFETY, OPERATION, MAINTENANCE AND STORAGE OF THIS PRODUCT. BEFORE USE, READ CAREFULLY AND UNDERSTAND ALL CAUTIONS, WARNINGS, INSTRUCTIONS AND PRODUCT LABELS. FAILURE TO DO SO COULD RESULT IN SERIOUS PERSONAL INJURY AND/OR PROPERTY DAMAGE.

IF YOU SHOULD HAVE ANY QUESTIONS OR EXPERIENCE A PROBLEM WITH YOUR ALLTRADE PRODUCT, DO NOT RETURN THIS PRODUCT TO THE STORE. PLEASE CALL OUR CUSTOMER SERVICE DEPARTMENT AT **1-800-590-3723**. BEFORE YOU CALL, HAVE THE FOLLOWING INFORMATION AVAILABLE: MODEL No., DATE PURCHASED AND STORE LOCATION. AN ALLTRADE REPRESENTATIVE CAN RESOLVE YOUR PROBLEM OVER THE PHONE. IF YOU WOULD LIKE TO MAKE A SUGGESTION OR COMMENT, GIVE US A CALL OR EMAIL US AT: INFO@ALLTRADETOOLS.COM. YOUR FEEDBACK IS VITAL TO US.

**FOR CUSTOMER SERVICE
POUR LE SERVICE APRÈS VENTE
OU DU CONSOMMATEUR**

**PARA EL SERVICIO
PARA EL CONSUMIDOR**

1-800-590-3723

Printed in China

Kawasaki

Kawasaki Motors Corp., U.S.A.

OFFICIAL • LICENSED • PRODUCT

87-1904-60957

KAWASAKI™ IS A TRADEMARK LICENSED BY KAWASAKI™ MOTORS CORP., U.S.A., WHICH DOES NOT MANUFACTURE OR DISTRIBUTE THIS PRODUCT. CONSUMER INQUIRES SHOULD BE DIRECTED TO:

©COPYRIGHT 2007 ALLTRADE TOOLS, LLC.

1431 VIA PLATA
LONG BEACH, CA 90810-1462 USA

691204 – 14" Cut-off Saw_Rev. 1/30/07

TABLE OF CONTENTS

CONGRATULATIONS!	2
INTENDED USE	2
SECTION ONE	
RECOGNIZE SAFETY SYMBOLS, WORDS AND LABELS	2-3
IMPORTANT SAFEGUARDS	3
SECTION TWO	
GENERAL SAFETY RULES – FOR ALL ELECTRIC POWER TOOLS	4-5
GROUNDING INSTRUCTIONS	5-6
EXTENSION CORD USAGE	6
IMPORTANT SAFETY RULES FOR CUT-OFF SAWS	7-10
SYMBOLS	11
SECTION THREE	
FUNCTIONAL DESCRIPTION	12
ASSEMBLY	12-18
UNLOCKING THE CUT-OFF SAW	13
REMOVING AND INSTALLING THE ABRASIVE CUTTING WHEEL	14-15
ADJUSTING THE WORK VISE	15-16
USING THE QUICK LOCK LEVER	17
ATTACHING THE VICE HANDLE	17
ATTACHING THE REAR SPARK SHIELD	18
OPERATING INSTRUCTIONS FOR THE CUT-OFF SAW	18-20
SECURING THE TRIGGER SWITCH	18-19
USING THE CUT-OFF SAW	19-20
SETTING THE CUT-OFF WHEEL DEPTH GAUGE	20
LASER GUIDE	20-22
OPERATING THE LASER	21
LASER SAFETY	22
SECTION FOUR	
MAINTENANCE AND CLEANING	23-24
TROUBLE SHOOTING	24-25
ACCESSORIES	26
SPECIFICATIONS	26
OTHER CONSUMER DO-IT-YOURSELF (DIY) TOOLS	27

SECTION FIVE

3 YEAR LIMITED WARRANTY	27-30
-------------------------	-------

CONGRATULATIONS!

Thanks for choosing this product. At Alltrade, our aim is to provide you with quality products at an affordable price, and we want you to be totally satisfied with your product and our Customer Service. If any help and advice is needed, please contact us at 1-800-590-3723. Properly cared for, this product will give you many years of satisfaction.

INTENDED USE

This product is intended for consumer use only. This tool is not designed for professional use. The power cord should only be used in approved electrical outlets as described in this manual. Failure to use the proper power cords and/or extension cords may result in fire or possible damage to the bench grinder.

RECOGNIZE SAFETY SYMBOLS, WORDS AND LABELS

WARNING

READ AND UNDERSTAND ALL INSTRUCTIONS. Failure to follow all instructions in this manual may result severe personal injury or death. Keep this manual and refer to it for Safety Instructions, Operating Procedures and Warranty.

The safety instructions provided in this manual are not intended to cover all possible conditions and practices that may occur when operating, maintaining and cleaning power equipment.

Always use common sense and pay particular attention to all the **DANGER**, **WARNING**, **CAUTION** and **NOTE** statements of this manual.



This is the safety alert symbol. It is used to alert you to potential personal injury hazards. Obey all safety messages that follow this symbol to avoid possible injury or death.

DANGER

DANGER indicates an imminently hazardous situation which, if not avoided, will result in death or serious injury.

WARNING

WARNING indicates a potentially hazardous situation which, if not avoided, could result in death or serious injury.

⚠ CAUTION

CAUTION indicates a potentially hazardous situation which, if not avoided, may result in minor or moderate injury.

CAUTION

CAUTION used without the safety alert symbol indicates a potentially hazardous situation which, if not avoided, may result in property damage.

NOTE

NOTE provides additional information that is useful for proper use and maintenance of this tool. If a **NOTE** is indicated make sure it is fully understood.

IMPORTANT SAFEGUARDS**⚠ DANGER**

People with electronic devices, such as pacemakers, should consult their physician(s) before using this product. Operation of electrical equipment in close proximity to a heart pacemaker could cause interference or failure of the pacemaker.

WARNING: Some dust created by power sanding, sawing, grinding, drilling and other construction activities contains chemicals known to the State of California to cause cancer, birth defects or other reproductive harm.

Some examples of these chemicals are:

- Lead from lead-based paints.
- Crystalline silica from bricks and cement and other masonry products, and arsenic and chromium from chemically-treated lumber.

Your risk from these exposures varies, depending on how often you do this type of work. To reduce your exposure to these chemicals: work in a well ventilated area, and work with approved safety equipment, such as dust masks that are specially designed to filter out microscopic particles.

WARNING: Handling the power cord on corded products may expose you to lead, a chemical known to the State of California to cause cancer and birth defects or other reproductive harm. *Wash hands after handling.*

SAVE THESE INSTRUCTIONS FOR FUTURE REFERENCE.

GENERAL SAFETY RULES – FOR ALL ELECTRIC POWER TOOLS**⚠ WARNING**

READ AND UNDERSTAND ALL INSTRUCTIONS. Failure to follow all instructions listed below may result in electric shock, fire and/or serious personal injury.

KEEP GUARDS IN PLACE AND IN WORKING ORDER.

REMOVE ADJUSTING KEYS AND WRENCHES. Form a habit of checking to see that keys and adjusting wrenches are removed from the tool before turning it on.

KEEP WORK AREA CLEAN. Cluttered areas and benches invite accidents.

DO NOT USE TOOL IN A DANGEROUS ENVIRONMENT. Do not use power tools in damp or wet locations, or expose them to rain. Keep work area well lit.

KEEP CHILDREN AWAY. All visitors should be kept a safe distance from the work area.

MAKE YOUR WORKSHOP CHILD PROOF, WITH PADLOCKS, MASTER SWITCHES, OR BY REMOVING STARTER KEYS.

DO NOT FORCE TOOL. The correct tool will do the job better and safer at the rate for which it is designed.

USE THE CORRECT TOOL FOR YOUR APPLICATION. Do not force tool or attachment to do a job for which it was not designed.

ALWAYS USE SAFETY GLASSES. Also use a face mask or dusk mask if cutting operation is dusty. Everyday eyeglasses only have impact lenses, they are **NOT** safety glasses.

WEAR PROPER APPAREL. Do not wear loose clothing, gloves, neckties, rings, bracelets, or other jewelry which may get caught in moving parts. Non-slip footwear is recommended. Wear protective hair covering to contain long hair.

SECURE WORK. Use clamps or other practical ways to secure and support the workpiece to a stable platform. Holding the work by hand or against your body is unstable and may lead to loss of control.

DO NOT OVERREACH. Keep proper footing and balance at all times. Proper footing and balance enables better control of the power tool in unexpected situations.

MAINTAIN TOOLS WITH CARE. Keep tools sharp and clean for best and safest performance. Follow instructions for lubricating and changing accessories.

DISCONNECT TOOLS BEFORE SERVICING AND WHEN CHANGING ACCESSORIES, SUCH AS BLADES, BITS, CUTTERS AND THE LIKE.

REDUCE THE RISK OF UNINTENTIONAL STARTING. Be sure switch is in the "OFF" position before plugging in.

⚠ WARNING

USE RECOMMENDED ACCESSORIES. Consult the owners manual for recommended accessories. The use of improper accessories may cause cause risk of injury.

NEVER STAND ON TOOL. Serious injury could occur if the tool is tipped or if the cutting tool is unintentionally contacted.

CHECK DAMAGED PARTS. Before further use of the tool, a guard or other part that is damaged should be carefully checked to determine that it will operate properly and perform its intended function. Check for alignment of moving parts, binding of moving parts, breakage of parts, mounting and any other conditions that may affect its operation. A guard or other part that is damaged should be properly repaired or replaced.

DIRECTION OF FEED. Only feed work into a blade or cutter against the direction of rotation of the blade or cutter.

GROUNDING INSTRUCTIONS

⚠ WARNING NEVER use appliances or equipment that have motors with automatic reset overload protective devices. These protective devices can cause unexpected startups that can cause property damage, severe personal injury, or death.

The electrical power source for this Cut-off saw **MUST** be grounded in order to prevent possible electric shock or even death should the tool malfunction or break down. Grounding provides a path of least resistance for electric current thus reducing the risk of electrical shock. The power source must also use a minimum 20A service. Multiple power tools should never be used on the same circuit at the same time.

⚠ WARNING Failure to properly ground this Cut-off saw could result in burns, severe electrical shock, and even death. This is especially true if used in damp or wet locations or near metallic plumbing. The reaction from electrical shock could possibly cause your hands to make contact with the cutting tools.

⚠ CAUTION Not all outlets are properly grounded, regardless of the type of receptacle they have. If you are not sure if the receptacle is properly grounded or not, consult a certified electrician. The AC receptacle must be protected by a dual element time delay or a circuit breaker.

This Cut-off saw is equipped with a grounded 3-wire power cord with a 3-prong plug. If the power cord will not fit into the wall plug, an approved adapter can be used as long as it is connected to the center screw in the wall plate. See Figure 1 and the steps below to use an AC grounding adapter:

1. Remove the cover plate mounting screw.
2. Insert the AC grounding adapter into the bottom receptacle so the green grounding lug fits over the screw hole.
3. Install the mounting screw back into the cover plate securely affixing the adapter to the receptacle.

⚠ WARNING Never modify the electrical adapter by cutting off the grounding prong so it will fit into unapproved, un-grounded electrical receptacles. Failure to follow this procedure could result in burns, severe electrical shock, or even death.

If you have questions about connecting the Cut-off saw, contact a certified electrician to install the proper circuitry needed for this and other power tools you use. Repair or replace any damaged electrical wiring **IMMEDIATELY**.

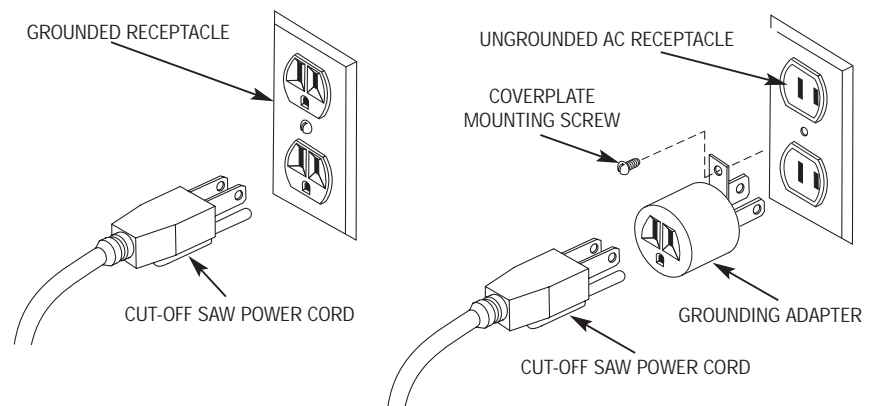

FIGURE 1. CONNECTING THE CUT-OFF SAW TO THE AC POWER RECEPTACLE

EXTENSION CORD USAGE

Extension cords are not recommended for use with this saw. Extension cords, if used, must be properly grounded with a 3-prong plug on one and a 3-hole receptacle on the other. **DO NOT use grounding adapters with an extension cord.** Extension cords must be UL listed and use a minimum of 18 A.W.G. wiring. Extension cords should never exceed 25 feet in length. Extension cords, that are too long, cause a voltage drop over the extra distance causing the saw motor to run slower with the possibility of causing damage to the motor. Using extension cords with smaller than the recommended wire gauge run the risk of getting too hot, melting, and/or causing fires. See table, "Extension Cord Specifications", on page 26.

IMPORTANT SAFETY RULES FOR CUT-OFF SAWS

WARNING

AVOID PROLONGED CONTACT WITH DUST created by the abrasive Cut-off saw. Allowing the dust to get into your mouth, eyes, or lay on your skin promotes the absorption of harmful chemicals into your body.

READ AND UNDERSTAND ALL INSTRUCTIONS. If there are instructions in this manual that are not completely understood, seek the advice of a trained professional or contact Alltrade Customer Service at 1-800-590-3723 before attempting to perform the procedures. Failure to follow all instructions listed in this manual may result in property damage, damage to the tool, or serious personal injury or even death.

UNPACK THE CUT-OFF SAW COMPLETELY FROM ITS CARTON. Inspect the saw and accessories and ensure they are free from defects or breakage due to shipping.

DO NOT OPERATE THIS CUT-OFF SAW until it is completely assembled according to the instructions in this manual. Failure to adhere to these instructions could result in serious and/or permanent injury to the operator.

MAKE SURE APPROVED EYE PROTECTION IS BEING WORN and properly adjusted and secured at all times the Cut-off saw is in use. Everyday eyeglasses only have impact resistant lenses and ARE NOT safety glasses. Safety glasses must conform to ANSI Z87.1 requirements. Approved safety glasses and goggles will have Z87 printed or stamped on them.

FOLLOW ALL WIRING CODES. Use only properly grounded three-hole grounded receptacles. DO NOT cut the third prong off the power cord. When using an extension cord, use only UL Listed extension cords with minimum 16 AWG wiring and a maximum length of 25 feet. See ELECTRICAL SAFETY section in this manual.

KEEP BYSTANDERS, CHILDREN, AND VISITORS at a safe distance from the Cut-off saw while it is in operation. Distractions can cause inadvertent misuse resulting in possible injury to the bystanders or to the operator.

WEAR PROPER APPAREL. Do not wear loose clothing, gloves, neckties, rings, bracelets, or other apparel that could possibly become caught in the moving parts of the Cut-off saw. When working in a shop environment around power tools, wear nonslip footwear. Use protective hair covering to contain long hair.

KEEP THE WORK AREA CLEAN AT ALL TIMES. Cluttered areas around the Cut-off saw can cause unexpected accidents if the debris comes in contact with the moving parts of the Cut-off saw.

WARNING

MAINTAIN A PROPER WORK ENVIRONMENT. Do not operate the Cut-off saw in damp or wet locations or expose it to rain. Water can cause the electrical components to malfunction resulting in damage to the Cut-off saw and/or serious injury or death to the operator.

DO NOT PERFORM ANY OPERATION FREEHAND.

ALWAYS USE APPROVED TABLE CLAMPS AND VICES to clamp workpieces to the Cut-off saw table to prevent breakage, damage to the Cut-off saw, the workpiece, and possible severe injury to the operator. Contact Alltrade Customer Service at 1-800-590-3723 (toll free) for authorized accessories.

USE ONLY ABRASIVE CUTTING WHEELS that are designed for the various speeds of this Cut-off saw. The abrasive cutting wheels should have an arbor size 5/8" OR SMALLER. Unsuitable cutting wheels can break without warning throwing fragments outward at high speeds possibly causing severe injuries. Contact Alltrade Customer Service at 1-800-590-3723 (toll free) for authorized abrasive wheel specifications.

DON'T FORCE THE TOOL. The Cut-off saw will do a better job and be safer if cutting operations are performed at the proper speeds as expressed in this manual.

ALWAYS EASE THE CUTTING WHEEL AGAINST THE WORKPIECE when starting a cutting operation. A sudden impact can cause the abrasive wheel to break sending fragments flying away from the Cut-off saw at high speeds resulting in possible severe injury to the operator.

DO NOT USE AN ABRASIVE WHEEL THAT WOBBLER OR VIBRATES. Visually inspect the abrasive wheels before they contact the workpiece ensuring there are no side-to-side movements. Should the abrasive wheel wobble from side-to-side or if the tip appears broken, replace them immediately. If the vibration still exists, check the bearings and the motor shaft and repair or replace them as soon as possible. EXCESSIVE VIBRATION can cause severe damage to both the workpiece and the Cut-off saw.

ADJUST THE TOOL TABLE BEFORE EACH USE. The tool table should be tightened and placed at the proper angle for the cutting job before the Cut-off saw is put into use. If not properly adjusted, the workpiece can unexpectedly move causing the abrasive wheel to seize resulting in damage to it or possible severe injury to the operator.

DO NOT STAND DIRECTLY IN FRONT OF THE CUT-OFF SAW when it is first turned on. Loose fragments could fly off at high speeds possibly causing injury.

⚠ WARNING

NEVER REACH AROUND THE SAW BLADE.

PROPERLY SUPPORT EXTRA LONG OR EXTRA WIDE WORKPIECES. Workpieces that are too long or too wide can tip and cause the abrasive wheel to seize resulting in a sudden kick back motion resulting in damage to the workpiece and Cut-off saw as well as possible severe injury to the operator.

NEVER START THE CUT-OFF SAW WITH THE WORKPIECE IN CONTACT WITH THE ABRASIVE WHEEL. The sudden start-up of the abrasive wheel could cause it to fracture resulting in pieces flying away from the Cut-off saw resulting in damage to the workpiece, the Cut-off saw, and/or serious injury to the operator.

DISCONNECT THE CUT-OFF SAW POWER CORD FROM THE AC OUTLET before making adjustments to the worktable, clamps, vises, workpieces, changing abrasive wheels, or changing the speed of the drill motor preventing the tool from accidentally turning on. Failure to adhere to this step could result in damage to both the workpiece and the Cut-off saw as well as possible severe injury to the operator.

TURN OFF TOOL AND WAIT FOR SAW BLADE TO STOP before moving workpiece or changing settings.

THOROUGHLY CLEAN THE CUT-OFF SAW BEFORE CHANGING TYPES OF WORKPIECES. Combining wood and metal dust can result in an explosion or fire. **CONSULT EXPERT ADVICE BEFORE CUTTING IN WORKPIECES MADE OF MAGNESIUM.** The friction generated by the abrasive wheel could cause the magnesium to ignite resulting in a very intense fire that could cause severe burns to the operator and/or seriously damage the Cut-off saw.

Magnesium fires cannot be extinguished using fire extinguisher with an "A", "B" or "C" rating. Only a class "D" extinguisher (for flammable metals) should be used. Do not attempt to extinguish a magnesium fire with water or other liquid. The result will be an explosive reaction that could result in severe burns or death to the operator.

Do not use the side of the abrasive wheel as a deburring grinder. This will substantially weaken the wheel causing an unsafe condition. The wheel could come apart sending fragments in all directions. Failure to adhere to this warning could result in serious damage to the tool and/or serious injury or even death to the operator.

Do not alter in any way, shape, or form the upper and lower guards around the abrasive cutting wheel. These guards are there to protect the operator against unexpected conditions, such as breaking, of the cutting wheel. Any modification of these guards voids the warranties set forth by the manufacturer.

⚠ WARNING

DO NOT OPERATE THE SAW WITHOUT GUARDS IN PLACE.

NEVER PERFORM CUTTING OPERATIONS NEAR FLAMMABLE GAS OR LIQUIDS. The resulting fire and/or explosion could cause permanent serious injuries to the operator and damage to the Cut-off saw and surrounding work area.

ALWAYS KEEP ARMS, HANDS, AND FINGERS away from the workpiece while it is on the table and the Cut-off saw is turned on. Keep hands out of the path of the saw blade. Severe injury could result.

DO NOT PERFORM ANY OPERATION FREEHAND.

ALWAYS CLAMP THE WORKPIECE FIRMLY AGAINST THE WORK TABLE. Never attempt to hold the workpiece by hand. The abrasive wheel can seize in the workpiece causing it to spin rapidly. This will cause loss of control of the workpiece resulting in severe injuries or damage to the workpiece and Cut-off saw.

NEVER APPLY A COOLANT DIRECTLY TO THE WORKPIECE WHILE IT IS IN CONTACT WITH THE ABRASIVE WHEEL. Coolant can weaken the makeup of the abrasive wheels causing them to fail.

NEVER PERFORM LAYOUT OR ASSEMBLY to workpieces in front of the Cut-off saw while it is still running. A sudden slip could bring hands in contact with the moving parts of the Cut-off saw resulting in injury to the operator.

REDUCE THE RISK OF UNINTENTIONAL STARTING. Ensure the "ON/OFF" switch is set to the "OFF" position before plugging the power cord into the AC outlet.

TURN THE ON/OFF SWITCH ON THE CUT-OFF SAW TO THE "OFF" POSITION AND UNPLUG THE POWER CORD FROM THE ELECTRICAL RECEPTACLE when the cutting operations are finished. Thoroughly clean the area surrounding the Cut-off saw making it ready for the next use.





NEVER LEAVE THE CUT-OFF SAW RUNNING UNATTENDED. WHEN FINISHED WITH A CUTTING OPERATION, TURN "OFF" THE CUT-OFF SAW AND WAIT UNTIL IT COMES TO A COMPLETE STOP.

SECURE THE ELECTRICAL POWER CORD WHEN THE CUT-OFF SAW IS NOT IN USE to prevent unauthorized use of the tool and/or to prevent children from accidentally turning it on.

ADDITIONAL INFORMATION about the proper use of bench-mounted Cut-off saws is available from the Power Tool Institute, 1300 Sumner Avenue, Cleveland, OH 44115-2851 (www.powertoolinstitute.com). Information is also available from the National Safety Council, 1121 Spring Lake Drive, Itasca, IL 60143-3201. Additionally, you can refer the U.S. Department of Labor Occupational Safety and Health Act (OSHA) 1910.213 Regulations.

SYMBOLS

IMPORTANT: Some of the following symbols may be used on your tool. Please study them and learn their meaning. Proper interpretation of these symbols will allow you to operate the tool better and safer.

SYMBOL	NAME	EXPLANATION
V	Volts	Voltage (Potential)
A	Amperes	Current
Hz	Hertz	Frequency (Cycles per Second)
W	Watt	Power
Kg	Kilograms	Weight
	Alternating Current	Type of Current
	Direct Current	Type of Current
	Alternating or Direct Current	Type of Current
	Earthing Terminal	Grounding Terminal
	Class II Construction	Denotes Double Insulation
min	Minutes	Time
s	Seconds	Time
ϕ	Diameter	Size of Drill Bits, Grinding Wheels, etc.
n_0	No load speed	No-load Rotational Speed
.../min	Revolutions per Minute	Revolutions, Surface Speed, Strokes, etc. per Minute
1,2,3, ...	Ring Selector Settings	Speed, Torque or Position Settings

FUNCTIONAL DESCRIPTION

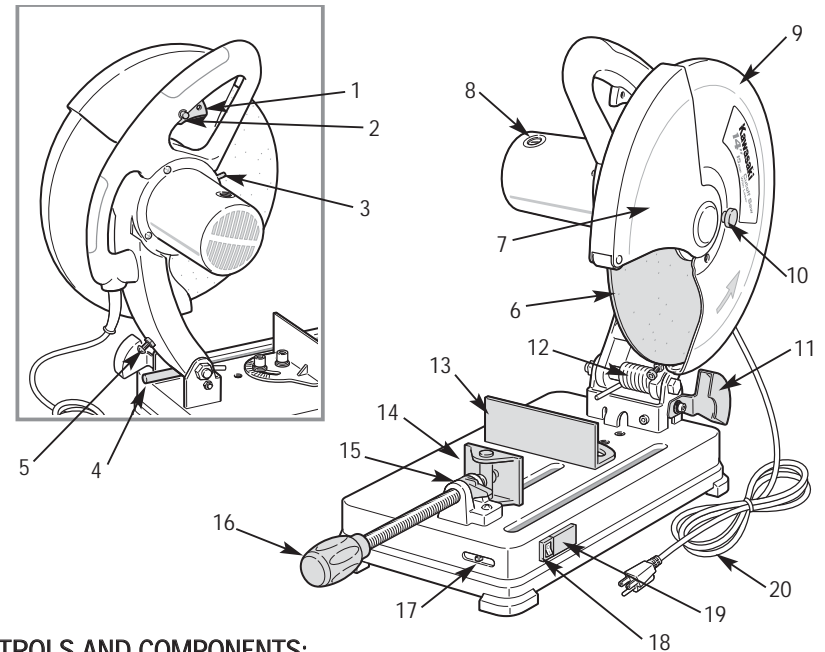

CONTROLS AND COMPONENTS:

- | | |
|------------------------------------|------------------------------------|
| 1. Trigger Switch | 10. Lower Guard Stop Knob |
| 2. Safety Button | 11. Rear Spark Shield |
| 3. Arbor Lock Lever | 12. Cutting Depth Adjustment Screw |
| 4. Spring Tension Adjustment Screw | 13. Fence |
| 5. Motor Arm Release | 14. Vise |
| 6. Abrasive Wheel | 15. Quick Release Lever |
| 7. Lower Guard | 16. Adjustable Screw Handle |
| 8. Motor Brushes | 17. Laser Aperture (inside) |
| 9. Upper Guard | 18. Laser On/Off Switch |
| | 19. Laser Battery Compartment |
| | 20. Grounded Power Cord |

ASSEMBLY

⚠ WARNING DO NOT connect the Cut-off saw to the AC power source until the receptacle is properly grounded. It is not recommended that an extension cord be used, but if one is necessary, follow the instructions below.

The 14" Cut-off saw comes pre-assembled from the factory.

TOOLS REQUIRED FOR ASSEMBLY

The tools, pictured, are supplied by the customer.

It is highly recommended that the 14" Cut-off saw be securely mounted to a tool stand. This is to prevent excessive vibration during use. Mount the Cut-off saw to the tool stand by:

1. Most tool stands have pre-drilled holes to accommodate a variety of tools.
2. If the tool stand does not have an exact match for the holes, try to align the tool base with as many pre-drilled holes as possible. Mark and drill new holes for mounts that have missing holes.
3. Insert four 1/4" X 20 screws and washers through the underside of the tool stand and up through the rubber feet on the base of the Cut-off saw. The length of the screws should be 1" (25mm).
4. Tighten the screws securely.

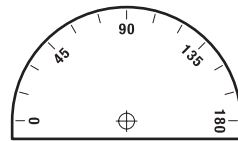

PROTRACTOR



ADJUSTABLE WRENCH



PHILLIPS SCREWDRIVER

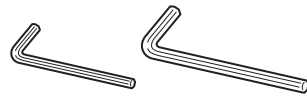

HEX (ALLEN) WRENCHES

UNLOCKING THE CUT-OFF SAW

⚠ WARNING Disconnect the abrasive Cut-off saw from the AC power source eliminating any accidental starting of the motor.

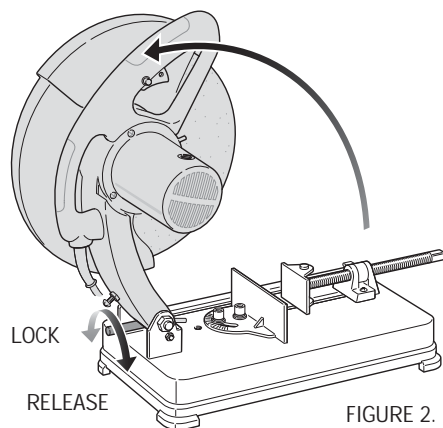

FIGURE 2. UNLOCKING THE CUT-OFF SAW

TO CARRY THE CUT-OFF SAW:

Fold down head to base and rotate the motor arm release to lock head.

TO UNLOCK THE CUT-OFF SAW:

To unlock tool and raise head depress motor arm slightly and rotate motor arm release. The motor arm will pivot upward. See Figure 2.

REMOVING AND INSTALLING THE ABRASIVE CUTTING WHEEL

REMOVING THE ABRASIVE CUTTING WHEEL:

1. Raise the abrasive wheel to its full open position.
2. Remove the Stop Knob on the movable blade guard.
3. Remove the movable blade guard exposing the attaching hex socket-head cap screw for the abrasive wheel.
4. Set the movable guard aside ensuring that it doesn't get bent or distorted.
5. Push the arbor shaft lock lever and rotate the abrasive wheel until the arbor lock engages locking the wheel in place.

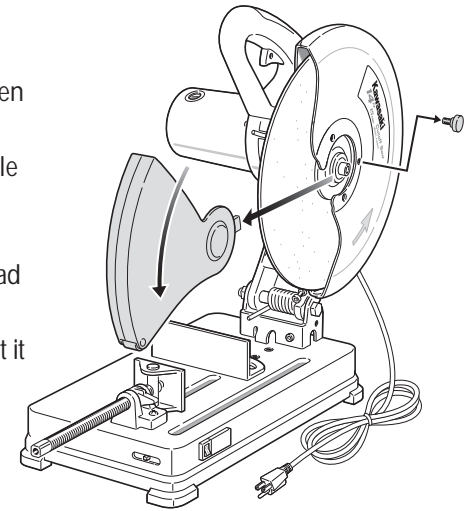

FIGURE 3. REMOVING BLADE GUARD

6. Hold the arbor shaft lock in place and use a 5/16" (8mm) hex wrench or hex bit, remove the hex socket-head cap screw by turning it counterclockwise. Also, remove the washer, outer flange, arbor adapter (if used), abrasive wheel, and inner flange. See Figure 4.

INSTALLING THE ABRASIVE CUTTING WHEEL:

1. Place the hex socket-head cap screw, washer, outer flange and arbor adapter (if used) through the hole in the new abrasive wheel.
2. Place the inner flange onto the screw protruding to the back side of the new abrasive wheel.
3. Holding the new abrasive wheel in one hand, align the screw into the threaded hole in the arbor.
4. Push in the arbor shaft lock lever and turn the new abrasive wheel until the shaft locks.

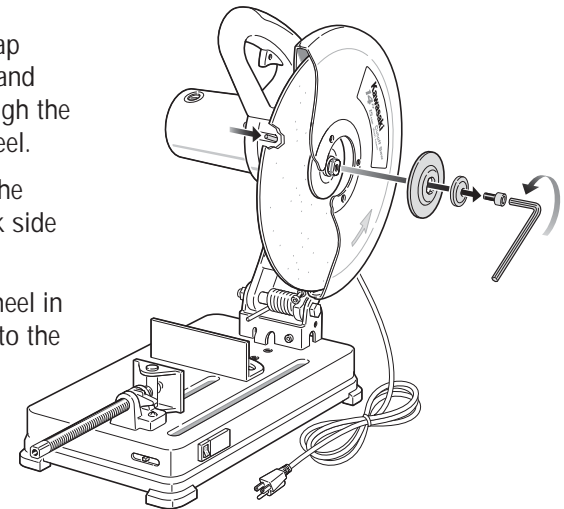

FIGURE 4. REMOVING/INSTALLING THE CUTTING WHEEL

5. Hold the arbor shaft lock in place and use a 5/16" (8mm) hex wrench or hex bit, turn the hex socket-head cap screw clockwise to tighten.
6. Tighten the hex socket-head cap screw securely into the motor arbor. See Figure 4.
7. Replace the movable blade guard exposing the covering hex socket-head cap screw for the abrasive wheel.
8. Replace nut on the movable blade guard.

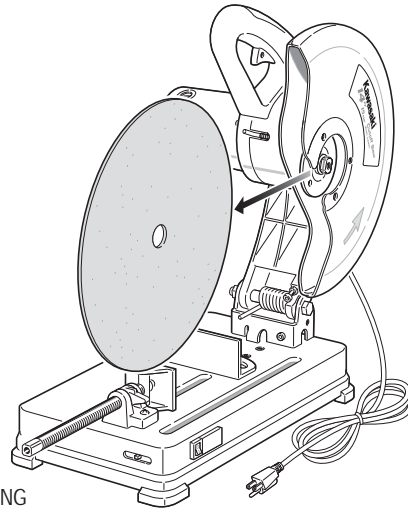

FIGURE 5. REMOVING/INSTALLING THE CUTTING WHEEL

⚠ WARNING

Do not over tighten the hex socket-head screw. Over tightening the screw can cause the abrasive wheel to crack resulting in premature failure. This could cause the abrasive wheel to break and fly off the arbor shaft when the trigger is engaged. Failure to adhere to this Warning could cause damage to the Cut-off saw and severe injury or even death to the operator.

Use only a 14" diameter abrasive Cut-off wheel rated to a minimum 4000 RPM. Cut-off wheels that do not match the mounting hardware, exceed a maximum 4400 RPM or fall below the minimum 4000 RPM may sustain premature wear or breakage and fly off the Cut-off saw or run eccentrically resulting in a loss of control. Failure to adhere to this Warning could cause damage to the Cut-off saw and severe injury or even death to the operator.

ADJUSTING THE WORK VISE

The work vise is located on the base of the Cut-off saw. The vise is made up of two parts: (1) a stationary fence which can be loosened and rotated from 0° to 45° degrees and (2) a movable clamp with an adjustable screw handle and a quick-release lock.

The work vise will also move toward the rear of the base to allow larger workpieces to be cut. To set up and adjust the work vise, follow the directions below. See Figure 6.

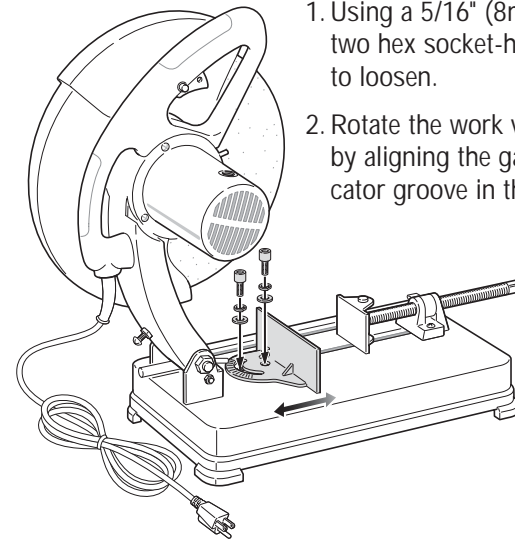
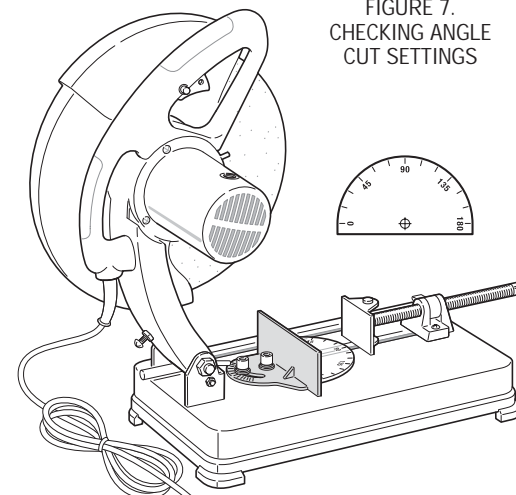

FIGURE 6. ADJUSTING THE WORK VISE

1. Using a 5/16" (8mm) hex wrench or hex bit, turn the two hex socket-head cap screws counterclockwise to loosen.
2. Rotate the work vise fence to the desired the angle by aligning the gauge on the vise base with the indicator groove in the Cut-off saw base.

3. Using a 5/16" (8mm) hex wrench or hex bit, turn the two hex socket-head cap screws clockwise to securely tighten.
4. Using a 5/16" (8mm) hex wrench or hex bit, turn the two hex socket-head cap screws counterclockwise and remove them.
5. Slide the stationary portion of the work vise over the last threaded hole in the Cut-off saw base.

FIGURE 7. CHECKING ANGLE CUT SETTINGS



6. Install one of the hex socket-head cap screws into the hole. DO NOT TIGHTEN AT THIS TIME.
7. Align the second hole of the work vise base with another threaded hole in the Cut-off base.
8. Install the second hex socket-head screw into the hole.
9. Using a 5/16" (8mm) hex wrench or hex bit, turn the two hex socket-head cap screws clockwise to loosen.

⚠ CAUTION

The angled cut settings on the fence base are only approximate settings. Always check the accuracy of angled cut settings using a protractor or bevel gauge.

USING THE QUICK LOCK LEVER

The work vise is equipped with a threaded screw clamp and handle for tightening the vise. The clamp is also equipped with a quick lock release mechanism as standard equipment. The clamp can be tightened against the workpiece in the vise by turning the handle clockwise and loosened by turning the handle counterclockwise. To use the quick lock release mechanism, follow the steps below. See Figure 8.

1. Release the tension on the screw clamp by turning the handle counterclockwise for 1/2 to 1 full turn.
2. Lift the quick lock lever up and pull back the screw clamp handle sliding the vise open.
3. To tighten, lift the quick lock lever up and push the screw clamp forward against the workpiece.
4. Push the quick lock lever down into release mechanism.
5. Turn the screw clamp clockwise to securely tighten the workpiece in the vise.

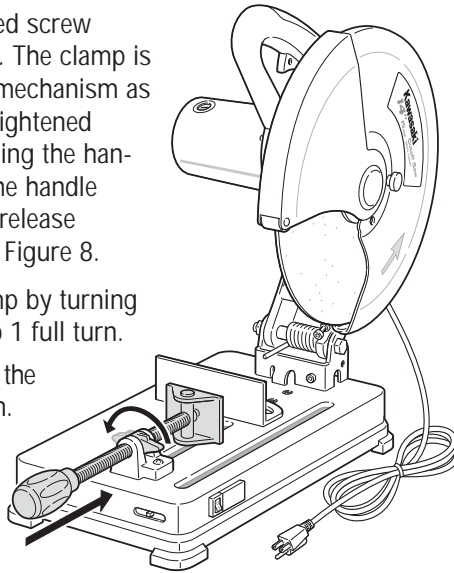

FIGURE 8. USING THE QUICK LOCK LEVER

ATTACHING THE VICE HANDLE

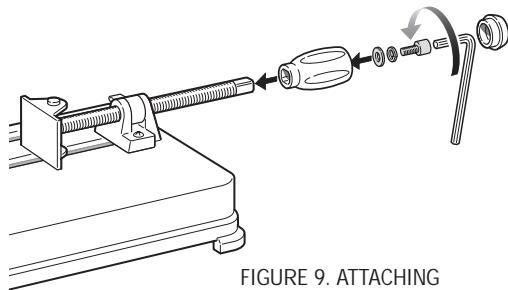

FIGURE 9. ATTACHING THE VICE HANDLE

1. Fit the vice handle onto the end of the vice.
2. Fit the spring washer over the hex screw followed by the flat washer.
3. Place the hex screw inside the vice handle and secure the vice handle to the vice by tightening the hex screw in a clockwise direction.
4. Fit the cap onto the vice handle.

ATTACHING THE REAR SPARK SHIELD

1. Place the spring washer over the hex bolt followed by the flat washer and then fit the hex bolt through the spark deflector. Place the spark shield in the correct position and tighten the hex bolt.
2. Tighten the hex bolt to secure the spark shield in position

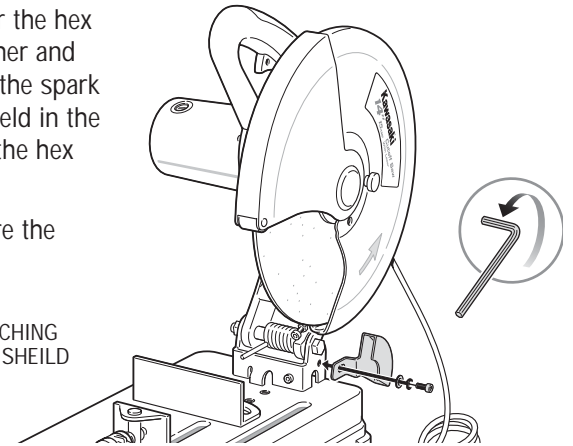
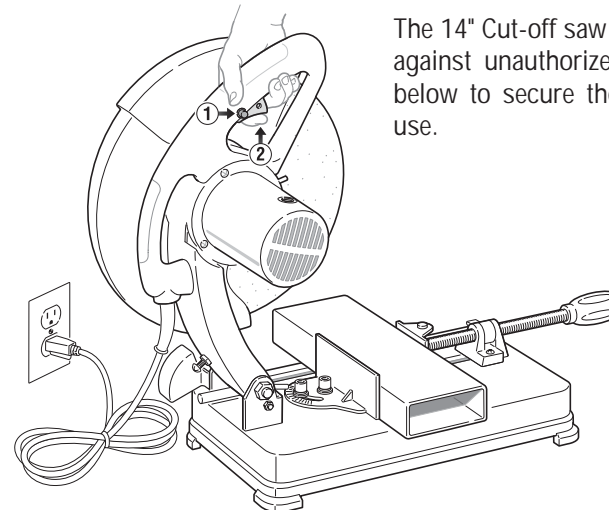

FIGURE 10. ATTACHING THE REAR SPARK SHIELD

OPERATING INSTRUCTIONS FOR THE CUT-OFF SAW

⚠ WARNING Do not use the Cut-off saw if the power cord (or extension cord, if used) is worn, cut, or damaged in any other way. A worn or damaged power cord must be replaced immediately. Contact Alltrade Customer Service to obtain the proper replacement power cord. Failure to adhere to this warning could result in damage to the Cut-off saw motor, fire, or severe electrical shock or even death to the operator.

SECURING THE TRIGGER SWITCH



The 14" Cut-off saw should always be protected against unauthorized usage. Follow the steps below to secure the Cut-off saw when not in use.

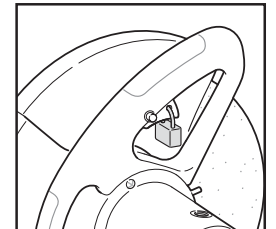

FIGURE 11. SECURING THE TRIGGER SWITCH

1. Release the trigger switch turning the saw off.
2. Place a padlock, with a shank diameter of 13/16" (21mm) or less, through the hole in the trigger and close it. This makes the trigger switch inoperable. See Figure 11.
3. Place the key for the padlock in a secure location.

USING THE CUT-OFF SAW

⚠ WARNING

Disconnect the abrasive Cut-off saw from the AC power source eliminating any accidental starting of the motor.

Before using the saw, ensure the wheel has cooled down from any previous actions. Wear approved leather work gloves when handling the various workpieces and to protect the hands from a hot Cut-off wheel.

FOLLOW THE INSTRUCTIONS BELOW TO OPERATE THE ABRASIVE CUT-OFF SAW. SEE FIGURE 12.

1. Adjust the angle of cut. See ADJUSTING THE WORK VISE on pages 15-16.
2. Turn the screw clamp clockwise to securely tighten the workpiece in the vise.
3. Plug the power cord into an approved GROUNDED AC receptacle.
4. Grip the handle and place thumb over the safety button.
5. Press the safety button with thumb. Squeeze the trigger switch. Release the safety button.
6. Allow the Cut-off saw to spin up to full speed.
7. Slowly pull down on the handle while continuing to squeeze trigger switch. Lower the Cut-off wheel slowly into the workpiece.

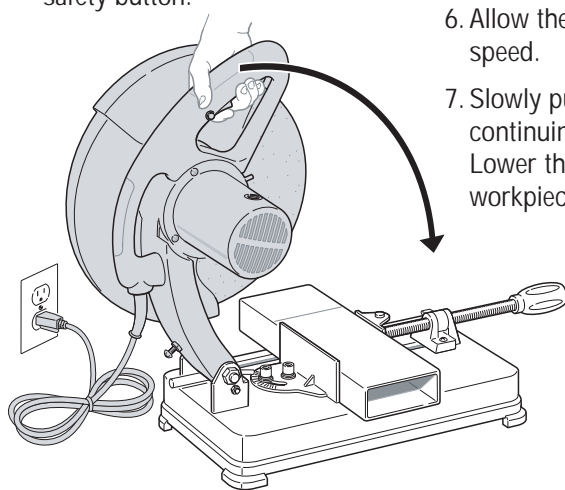

FIGURE 12. USING THE CUT-OFF SAW

8. Ensure the abrasive Cut-off wheel cuts completely through the workpiece. Should the Cut-off wheel fail to pass through the workpiece, raise the handle until it clears. Turn off the Cut-off saw and remove the power cord from the AC receptacle. Refer to SETTING THE CUT-OFF WHEEL DEPTH GAUGE.

9. Once the cut is completed, turn off the Cut-off saw by releasing the trigger switch. This also allows the safety button to return to the "OFF" position. See Figure 8.
10. Unplug the Cut-off saw from the AC power source. Ensure the abrasive wheel has stopped spinning before removing the workpiece.
11. Use a dry, soft bristle, brush or an air hose and clean any debris remaining from the cut.
12. Lock down the Cut-off saw with the swing lock handle. Using a pad lock secure the trigger switch. Store the abrasive Cut-off saw in a dry safe location.

SETTING THE CUT-OFF WHEEL DEPTH GAUGE

The cutting depth of the abrasive Cut-off wheel can be set using the adjustment screw on the wheel housing. See Figure 13.

1. Locate the depth adjustment screw.
2. Adjust the screw counterclockwise to increase the depth of cut. Tighten the jam nut.
3. Loosen the jam nut and turn the screw clockwise to decrease the depth of cut. Tighten the jam nut.

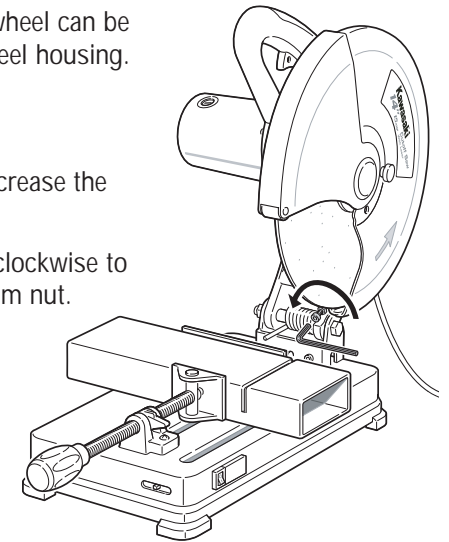

FIGURE 13. SETTING THE DEPTH GAUGE

⚠ CAUTION For cutting sections of the workpiece completely off, ensure the depth adjustment screw is set allowing the abrasive Cut-off wheel to go beyond the base surface into the groove provided.

LASER GUIDE

⚠ CAUTION Use of controls or procedures, or performance of procedures other than those specified herein may result in hazardous radiation exposure.

OPERATING THE LASER

⚠ WARNING Do not stare directly into the Laser beam, aperture or into a reflection from a mirror-like surface.

The laser runs on two AAA batteries which are located beneath the "ON/OFF" switch.

When the laser light begins to dim, change both batteries. NEVER mix old batteries with new.

TO CHANGE LASER BATTERIES:

1. Open battery compartment cover.
2. Make sure batteries are correctly positioned according to the positive/negative markings on the compartment.
3. Close cover.

FIGURE 14. CHANGING LASER BATTERIES

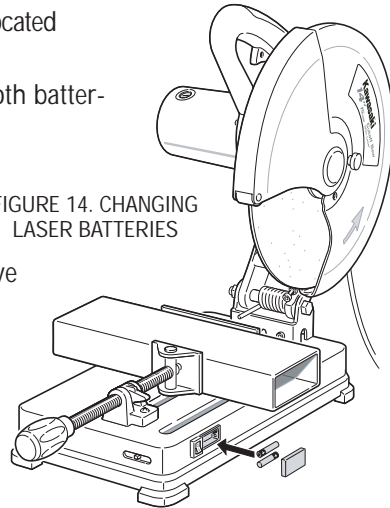

USING THE LASER LIGHT:

1. Place the workpiece on the table.
2. Turn the laser switch to the ON position.
3. To adjust the laser line turn the laser adjustment knob in a counter-clockwise direction to loosen it and then move it to the left or right until the laser line is in line with the blade. Turn the laser adjustment knob in a clockwise direction to tighten.

FIGURE 15. USING THE LASERLIGHT

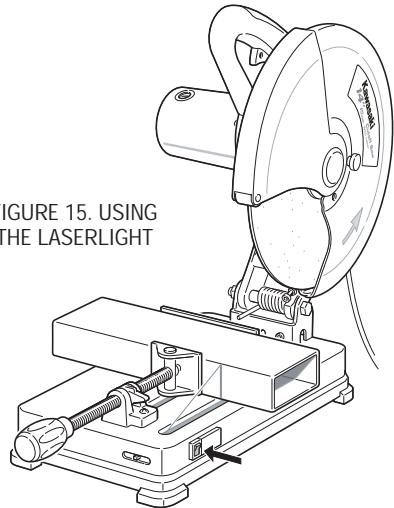

The laser guide does not normally present an optical hazard, although staring at the beam may cause flash blindness.

⚠ WARNING It may be more difficult to see the laser line in conditions of bright sunshine and on certain surfaces.

LASER SAFETY

⚠ WARNING

NEVER LOOK INTO THE LASER BEAM. Any contact with the eyes by the beam could cause injury. Do not use the laser when cutting reflective materials.

DO NOT AIM THE LASER BEAM AT ANYONE OR AT REFLECTIVE SURFACES. CLASS 2M LASER PRODUCT. Any contact with the eyes by the beam could cause injury. Ensure the laser beam is turned on only when the tool is on a non-reflective workpiece and as such it is aimed only at the work surface. Metals and other materials like steel which can be highly reflective should only be cut without the use of the laser.

STORE OUT OF REACH OF CHILDREN. Equipment should be in a high location or locked up to keep out of reach of children. It is not a toy.

DO NOT TAMPER WITH THE LASER OUTPUT. Changing the performance of the laser to increase its output is prohibited. Any claim for damages or injuries resulting from not following these instructions will be refused.

OPERATION ACCESSIBLE FIELDS:

Wavelength	636-660nm
Laser Power for Classification	<1mW CW

NEVER OPERATE LASER IF THE UNIT IS DEFECTIVE OR THE COVER OR SEAL IS DAMAGED.

DO NOT SERVICE LASER. The laser unit must be returned to the factory for any service or repair. Service or repair must be handled by authorized factory trained technicians.

Do not open the laser unit except to change batteries.

REMOVE BATTERIES IF THE LEVEL IS TO BE STORED FOR ANY LENGTH OF TIME. Batteries may leak and damage the laser if it is stored idle for more than 3 months.

Be careful with this tool. Striking or jarring it, especially on the laser housing, can affect its accuracy.

Other than batteries, there are no user-serviceable parts in the laser device.

LASER LIGHT
DO NOT VIEW DIRECTLY WITH OPTICAL
INSTRUMENTS (MAGNIFIERS)
CLASS 2M LASER PRODUCT
635-660nm, <1mW CW
CLASSIFIEDS PER IEC 60825-1, Ed. 1.2, 2001-08

AVOID EXPOSURE - LASER LIGHT IS
EMITTED FROM THIS APERTURE."



LASER RADIATION
CAUTION LABEL

MAINTENANCE AND CLEANING

⚠ WARNING

Disconnect the abrasive Cut-off saw from the AC power source eliminating any accidental starting of the motor.

Before using the Cut-off saw, a thorough inspection should be made. Check for the following:

1. Loose screws
2. Misalignment or binding of moving parts
3. Cracked or broken parts
4. Damaged electrical wiring
5. Cracked, chipped or bent Cut-off wheel

If any abnormal sounds are heard or abnormal smells or smoke is visible when Cut-off saw is started, **DISCONTINUE USE IMMEDIATELY, TURN OFF SAW AND REMOVE IT FROM THE AC POWER SOURCE.** These could be warning signs of imminent **DANGER.** **DO NOT USE CUT-OFF SAW IF ANY DAMAGE IS SUSPECTED.** Failure to adhere to this **WARNING** could result in damage to the tool or severe injury or death to the operator.

CLEANING

Daily: Using a soft-bristled brush, cloth, or shop vacuum, remove all clippings, dust, or other debris around the Cut-off saw. Follow the cleaning by using premium light-weight machine oil and lubricate all movable parts.

⚠ WARNING

DO NOT USE MACHINE OIL OF THE ABRASIVE CUT-OFF WHEEL. Machine oil will absorb into the abrasive material making up the wheel and potentially weakening it causing it to break. Should the Cut-off wheel break while it is in motion, pieces could fly off at high speed damaging the Cut-off saw, the workpiece or resulting in serious injury or even death to the operator.

MAINTENANCE

The abrasive Cut-off saw is virtually maintenance free. Closed-type, grease-sealed ball bearings are used throughout the Cut-off saw. These bearings are packed with grease at the factory and should last the life of the Cut-off saw. The only required maintenance is covered in the CLEANING Section above. If this particular model Cut-off saw is equipped with replaceable carbon brushes on the motor, there may become a time they need replacing. See Figure 16.

TO REPLACE THE CARBON BRUSHES:

1. Locate the brushes. They should be both sides of the motor housing at 180° degrees apart.
2. Use a slotted blade screwdriver and turn the brush caps counterclockwise.
3. Remove the caps, tension springs, and carbon brushes.
4. Place new carbon brushes into the openings.
5. Place the curved end of the brush into opening first, followed by a tension spring.
6. Insert the cap and, using a slotted blade screwdriver, tighten the caps by turning clockwise.

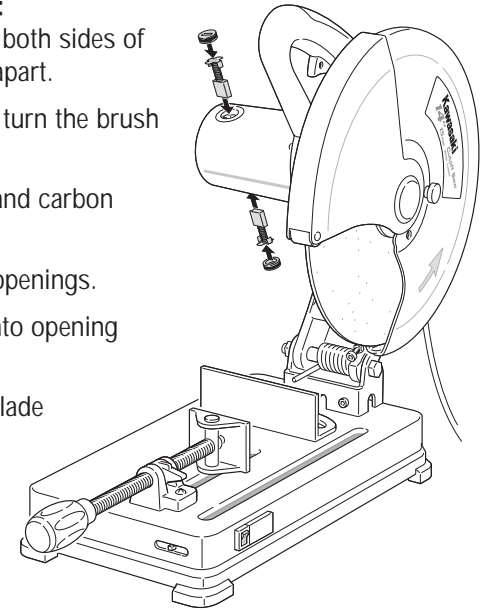

FIGURE 16. REPLACING CARBON BRUSHES

Should the carbon brushes be worn more than 1/2 the original size, replace both brushes. Ensure the springs operate freely and the tension doesn't cause armature of the motor to drag or make noise.

NOTE

New carbon brushes may arc or spark until they wear slightly and conform to the armature of the motor. This is a normal occurrence.

TROUBLESHOOTING

⚠ WARNING

To avoid any accidental starting of the saw, turn the switch to the "OFF" position, remove the safety key, and unplug the tool from the AC power source.

Should the motor fail to run, for any reason, call Alltrade Customer Service.

TROUBLE	PROBABLE CAUSE	SOLUTION
Cut-off saw will not start	<ol style="list-style-type: none"> 1. Tool not plugged in 2. Tripped circuit breaker or blown fuse 3. Power cord damaged 4. Worn or damaged carbon brushes 	<ol style="list-style-type: none"> 1. Plug in Cut-off saw. 2. Reset circuit breaker or replace fuse. 3. Have power cord replaced by authorized service center. 4. Replace carbon brushes.
Cut-off saw makes unsatisfactory cuts	<ol style="list-style-type: none"> 1. Glazed cutting wheel 2. Workpiece incorrectly clamped in vise 	<ol style="list-style-type: none"> 1. Dress the wheel or replace with a new one. 2. Securely clamp and support workpiece.
Cut-off wheel does not come up to speed	<ol style="list-style-type: none"> 1. Extension cord too light or too long 2. Low voltage from AC power source 	<ol style="list-style-type: none"> 1. Replace Cord. 2. Consult certified electrical contractor.
Cut-off saw vibrates excessively during cut	<ol style="list-style-type: none"> 1. Saw not mounted securely to workbench 2. Damaged Cut-off wheel 3. Workpiece incorrectly clamped in vise 	<ol style="list-style-type: none"> 1. Tighten all mounting hardware. See Figure 1. 2. Replace Cut-off wheel. 3. Clamp workpiece securely in vise.
Cut-off saw does not make accurate cuts	<ol style="list-style-type: none"> 1. Fence improperly adjusted 2. Cut-off wheel not square to fence 3. Excessive force used to make cut 4. Workpiece moving 	<ol style="list-style-type: none"> 1. Inspect and adjust fence. 2. Inspect and adjust wheel. 3. Reduce pressure on cuts - let wheel do cutting. 4. Clamp workpiece securely in vise.
Cannot move Cut-off saw arm	<ol style="list-style-type: none"> 1. Auto retracting wheel guard binding 	<ol style="list-style-type: none"> 1. Check for damaged parts. Repair or replace as needed.
Material moves during cutting	<ol style="list-style-type: none"> 1. Fence slipping or workpiece incorrectly clamped 2. Vise not securely clamping workpiece 3. Excessive force used to make cut 	<ol style="list-style-type: none"> 1. Tighten fence. 2. Clamp workpiece securely in vise. 3. Reduce pressure on cuts - let wheel do cutting.

ACCESSORIES

Optional accessories for the Cut-off saw can include wire-brush wheels that can be used for cleaning and layered cloth wheels that can be used for polishing and buffing. Contact **ALLTRADE Customer Service** at **1-800-590-3723 (toll free)** to find out what accessories are available for the Cut-off saw.

⚠ WARNING Only use accessories that are designed to fit your particular Cut-off saw. These accessories should be specifically labeled to match the speed and arbor size of the grinder. Failure to use the proper accessories could result in property damage, damage to the grinder, and serious personal injury to the operator.

Always attach grounded (3-prong) extension cords to grounded (3-hole) outlets. If the Cut-off saw must be used outside, use an extension cord labeled "W-A" or "W." These extension cords are rated for outdoor use and reduce the chances of electrical shock.

If you must use an extension cord, be sure that the gauge is large enough to carry the amount of current necessary for your power tool. If not, your tool may experience a loss of power, excessive voltage drop or overheating. The smaller the gauge number, the heavier the cord (see table below).

RECOMMENDED SIZES OF EXTENSION CORDS 120 VOLT AC 60 HZ TOOLS

TOOL CURRENT RATING	CONDUCTOR SIZE IN A.W.G				
	AMPERE	10FT.	25FT.	50FT.	100FT.
3-6	18	18	18	18	18
6-8	18	18	18	18	16
8-10	18	18	18	18	14
10-12	16	16	14	14	14
12-16	14	12	12	12	-
16-20	12	12	12	12	-

SPECIFICATIONS

SPECIFICATIONS	
Voltage	120V  60 Hz
Rated Current	15.0A
No Load Speed	3750 RPM
Wheel Diameter	14"
Cutting Depth	4 1/4"
Max Capacity (Round)	4 1/2"
Max Capacity (Rectangular)	4"X6"

OTHER CONSUMER DO-IT-YOURSELF (DIY) TOOLS

Alltrade offers a full range of Kawasaki™ tools that make DIY jobs easy. If you would like further information on the following products, please contact Alltrade Customer Service Department at 1-800-590-3723.

- Cordless Drills/Screwdrivers
- Impact Wrenches
- Sanders
- Jigsaws
- Circular Saws
- Angle Grinders
- Reciprocating Saws
- Routers
- Rotary Tools
- Corded and Cordless Multi-Purpose Tools
- Wide Range of Accessories and more

3 YEAR LIMITED WARRANTY

Express and Exclusive Limited Warranty to Original Retail Buyer

Alltrade Tools LLC (hereinafter "Alltrade") expressly warrants to the original retail purchaser of the accompanying KAWASAKI™ power tool and no one else all parts of the product (except those parts referred to below which are specifically excluded from such warranty (see Exclusions)) to be free from defects in materials and workmanship for a period of three years from original date of purchase, except that such warranty with regard to the battery shall be for a period of two years from original date of purchase, unless the tool is used for commercial or rental purposes.

SPECIAL WARRANTY NOTE FOR COMMERCIAL OR RENTAL USE: The above warranty for this Kawasaki™ power tool, including the battery, shall be effective for only 90 days from the original date of purchase if this tool is used for any **COMMERCIAL OR RENTAL PURPOSE.**

The date of purchase shall be the date of shipment to the original purchaser, or the date the original purchaser took possession, custody or control of the product, whichever occurred first. This warranty shall be null and void if the product or any component thereof is modified or altered. This warranty does not apply to any other product and/or component thereof manufactured or distributed by Alltrade,

and does not apply to products and/or components thereof designed, manufactured and/or assembled by others, for which Alltrade makes no warranties whatsoever. **THERE ARE NO WARRANTIES WHICH EXTEND BEYOND THE DESCRIPTION ON THE FACE HEREOF.**

Warranty Performance

By purchasing the product, purchaser expressly acknowledges and agrees that their sole and exclusive remedy under this warranty shall be strictly limited to the repair or replacement of any covered nonconforming items or parts thereof provided that any such nonconforming item and/or part is promptly returned to Alltrade's facility postage pre-paid and insured (address: ALLTRADE Warranty Claims & Repair, 1431 Via Plata, Long Beach, CA 90810, Attn: Customer Service #1-800-590-3723) within the applicable warranty period, with a written request by purchaser that Alltrade repair and/or replace the nonconforming item and/or part. We recommend that you keep the original product packaging in the event you need to ship the unit. We suggest the package be insured against loss or in transit damage. When sending your product include your name, address, phone number, dated proof of purchase (or copy), and a statement about the nature of problem. Warranty coverage is conditioned upon purchaser furnishing Alltrade with adequate written proof that they are the original purchaser and of the original purchase date. Parts returned, freight prepaid and insured, to Alltrade's facility (see above address) will be inspected and, at Alltrade's option, repaired and/or replaced free of charge if found to be defective and subject to warranty. Alltrade retains the sole discretion to determine whether any item or part is nonconforming and, if so, whether the item and/or part will be repaired and/or replaced. If the unit is repaired, new or reconditioned replacement parts may be used. If Alltrade chooses to replace the product, it may replace it with a new or reconditioned one of the same or comparable design. The repaired or replaced unit will be warranted under the terms of the remainder of the warranty period. Typically, a defective product that is returned within the first 30 days after the purchase date will be replaced; for items returned after the first 30 days and within the warranty period, covered defective parts not subject to normal wear and tear or other exclusions will be repaired or replaced, at Alltrade's option. During the warranty period, Alltrade will be responsible for the return shipping charges. Alltrade's repair and/or replacement of any nonconforming item and/or part thereof shall constitute fulfillment of all obligations to the purchaser. Alltrade shall not be responsible or liable for any expense, including freight charges, or repairs made outside Alltrade's facility, unless expressly agreed to by Alltrade in writing. Under no circumstances shall Alltrade bear any responsibility for loss of the unit, loss of time or rental, inconvenience, commercial loss or consequential damages.

Exclusions

This warranty does not cover parts damaged due to normal wear, abnormal conditions, misapplication, misuse, abuse, accidents, operation at other than recommended pressures or temperatures, improper storage or freight damage. Parts damaged or worn by operation in dusty environments are not warranted. Failure to follow recommended operating and maintenance procedures also voids warranty.

This limited warranty does not apply to accessory items such as drill bits, screwdriving bits, circular saw blades, jigsaw blades, grinding wheels, sanding sheets and other related items.

DAMAGE TO THE PRODUCT RESULTING FROM TAMPERING, ACCIDENT, ABUSE, NEGLIGENCE, FAILURE TO FOLLOW INSTRUCTIONS, UNAUTHORIZED REPAIRS OR ALTERATIONS, DAMAGE WHILE IN TRANSIT TO OUR SERVICE FACILITY, USE OF UNAPPROVED OR IMPROPER ATTACHMENTS OR ACCESSORIES, COMMERCIAL AND RENTAL APPLICATIONS OR OTHER CAUSES UNRELATED TO PROBLEMS WITH MATERIAL OR WORKMANSHIP ARE NOT COVERED BY THIS WARRANTY.

Alltrade will not be liable for the following: labor charges, loss or damage resulting from improper operation, maintenance or repairs made by other persons; pre-delivery services such as assembly, oil or lubricants, and adjustment; maintenance services that are normally required to maintain the product.

The use of other than genuine Alltrade Repair Parts will void warranty.

Warranty Disclaimers

EXCLUSION AND DISCLAIMER OF ALL OTHER EXPRESS WARRANTIES, GUARANTIES AND/OR REPRESENTATIONS. EXCEPT FOR THE LIMITED WARRANTY PROVIDED ABOVE, ALL OTHER EXPRESS WARRANTIES, GUARANTIES AND/OR REPRESENTATIONS BY ALLTRADE AND/OR ITS REPRESENTATIVE(S) REGARDING THE DESIGN, MANUFACTURE, PURCHASE, USE AND/OR OPERATION OF THE PRODUCT OR ANY COMPONENT THEREOF SOLD HEREUNDER, REGARDLESS OF WHETHER ANY SUCH WARRANTY, GUARANTY AND/OR REPRESENTATION, WRITTEN OR ORAL, ARISES BY OPERATION OF LAW AND/OR EQUITY AND/OR BY ANY ACT OR OMISSION OF ALLTRADE AND/OR ITS REPRESENTATIVE(S), OR THE BUYER, ARE HEREBY EXPRESSLY EXCLUDED AND DISCLAIMED BY ALLTRADE AND/OR ITS REPRESENTATIVES. PURCHASER KNOWINGLY AND WILLINGLY WAIVES ANY AND ALL SUCH WARRANTIES AND RIGHTS, CLAIMS AND/OR CAUSES OF ACTION ARISING THEREFROM OR BASED THEREON. PURCHASER'S SOLE AND EXCLUSIVE REMEDY IS AS STATED ABOVE.

EXCLUSION AND DISCLAIMER OF ALL IMPLIED WARRANTIES, INCLUDING THE IMPLIED WARRANTIES OF MERCHANTABILITY AND FITNESS FOR A PARTICULAR

PURPOSE. NO WARRANTY, ORAL OR WRITTEN, OTHER THAN THE ABOVE WARRANTY IS MADE WITH REGARD TO THIS PRODUCT. ALL EXPRESS AND/OR IMPLIED WARRANTIES, GUARANTIES AND/OR REPRESENTATIONS BY ALLTRADE AND/OR ITS REPRESENTATIVE(S) REGARDING THE DESIGN, MANUFACTURE, PURCHASE, USE AND/OR OPERATION OF THE PRODUCT OR ANY COMPONENT THEREOF SOLD HEREUNDER, REGARDLESS OF WHETHER ANY SUCH WARRANTY, GUARANTY AND/OR REPRESENTATION, WRITTEN OR ORAL, ARISES BY OPERATION OF LAW AND/OR EQUITY AND/OR BY ANY ACT OR OMISSION OF ALLTRADE AND/OR ITS REPRESENTATIVE(S), OR THE PURCHASER, INCLUDING BUT NOT LIMITED TO THE IMPLIED WARRANTY OF MERCHANTABILITY AND THE WARRANTY OF FITNESS FOR A PARTICULAR PURPOSE, ARE HEREBY EXPRESSLY EXCLUDED AND DISCLAIMED BY ALLTRADE AND/OR ITS REPRESENTATIVES. PURCHASER KNOWINGLY AND WILLINGLY WAIVES ANY AND ALL SUCH WARRANTIES AND RIGHTS, CLAIMS AND/OR CAUSES OF ACTION ARISING THEREFROM OR BASED THEREON. PURCHASER'S SOLE AND EXCLUSIVE REMEDY IS AS STATED ABOVE.

Limitation Of Liability

IN NO EVENT SHALL ALLTRADE AND/OR ITS REPRESENTATIVE(S) BE LIABLE FOR INDIRECT, INCIDENTAL, SPECIAL AND/OR CONSEQUENTIAL DAMAGES OF ANY KIND ARISING OUT OF OR RELATED TO, DIRECTLY OR INDIRECTLY, ANY BREACH OF ANY PROVISION OF ANY AGREEMENT BETWEEN ALLTRADE AND/OR ITS REPRESENTATIVE(S) AND PURCHASER, ANY WARRANTY HEREUNDER, AND/OR THE EXISTENCE, DESIGN, MANUFACTURE, PURCHASE, USE AND/OR OPERATION OF ANY ITEM(S) SOLD HEREUNDER EVEN IF ALLTRADE AND/OR ITS REPRESENTATIVE(S) HAS BEEN ADVISED OF THE POSSIBILITY OF ANY SUCH DAMAGES. IN NO EVENT, WHETHER AS A RESULT OF A BREACH OF CONTRACT, WARRANTY, TORT (INCLUDING NEGLIGENCE) OR OTHERWISE, SHALL ALLTRADE'S AND/OR ITS REPRESENTATIVE(S)' LIABILITY EXCEED THE PRICE OF THE PRODUCT. ANY AND ALL LIABILITY CONNECTED WITH THE USE OF THIS PRODUCT SHALL TERMINATE UPON THE EXPIRATION OF THE WARRANTY PERIODS SPECIFIED ABOVE.

Limitations on Warranty Disclaimers

Some states do not allow limitations on how long an implied warranty lasts and some states do not allow the exclusion or limitation of the incidental or consequential damages, so part or all of the above limitations or exclusions may not apply to you. This warranty gives you specific legal rights, and you may also have other rights which vary from state to state.

If your product is not covered by this warranty, please call our Customer Service Department toll free at 1-800-590-3723 for general repair information and charges.

Free Manuals Download Website

<http://myh66.com>

<http://usermanuals.us>

<http://www.somanuals.com>

<http://www.4manuals.cc>

<http://www.manual-lib.com>

<http://www.404manual.com>

<http://www.luxmanual.com>

<http://aubethermostatmanual.com>

Golf course search by state

<http://golfingnear.com>

Email search by domain

<http://emailbydomain.com>

Auto manuals search

<http://auto.somanuals.com>

TV manuals search

<http://tv.somanuals.com>