

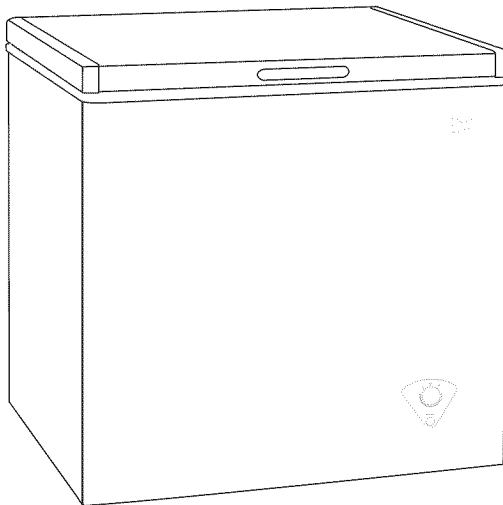

CHEST FREEZER

Use & Care Guide

Models: 19502/19702



ENGLISH

CAUTION:

BEFORE USE, PLEASE READ AND FOLLOW ALL SAFETY RULES AND OPERATING INSTRUCTIONS.

Sears Brands Management Corporation, Hoffman Estates, IL 60179 U.S.A.

www.sears.com

P/N 318205132 Rev. A



TABLE OF CONTENTS

Product Warranty	2
Model and Serial Number section	3
Parts and Features	4
Chest Freezer Safety	5
Important Safeguards	6
Important Safety Instructions	7
Installation Instructions	8
▶ Before Using Your Freezer	
▶ Installation of Your Freezer	
▶ Electrical Connection	
Operating Your Freezer	9
▶ Temperature Control	
▶ Defrosting Your Freezer	
▶ The Freezer Compartment	
Care and Maintenance	12
▶ Cleaning Your Freezer	
Vacation Time	12
▶ Moving Your Freezer	
▶ Energy Saving Tips	
Troubleshooting Guide	14
Master Protection Agreements	16

KENMORE LIMITED WARRANTY



When installed, operated and maintained according to all instructions supplied with the product, if this appliance fails due to a defect in material and workmanship within one year from the date of purchase, call 1-800-4-MY-HOME® to arrange for free repair.

If this appliance is ever used for other than private family purposes, this warranty applies for only 90 days from the date of purchase.

This warranty covers only defects in material and workmanship. Sears will NOT pay for:

1. Expendable items that can wear out from normal use, including but not limited to filters, belts, light bulbs, and bags.
2. A service technician to instruct the user in correct product installation, operation or maintenance.
3. A service technician to clean or maintain this product.
4. Damage to or failure of this product if it is not installed, operated or maintained according to the all instructions supplied with the product.
5. Damage to or failure of this product resulting from accident, abuse, misuse or use for other than its intended purpose.
6. Damage to or failure of this product caused by the use of detergents, cleaners, chemicals or utensils other than those recommended in all instructions supplied with the product.
7. Damage to or failure of parts or systems resulting from unauthorized modifications made to this product.

Disclaimer of implied warranties: limitation of remedies

Customer's sole and exclusive remedy under this limited warranty shall be product repair as provided herein. Implied warranties, including warranties of merchantability or fitness for a particular purpose, are limited to one year or the shortest period allowed by law. Sears shall not be liable for incidental or consequential damages. Some states and provinces do not allow the exclusion or limitation of incidental or consequential damages, or limitation on the duration of implied warranties of merchantability or fitness, so these exclusions or limitations may not apply to you.

This warranty applies only while this appliance is used in the United States or Canada.

This warranty gives you specific legal rights, and you may also have other rights which vary from state to state.

Sears, Roebuck and Co., Hoffman Estates, IL 60179

Sears Canada Inc., Toronto, Ontario, Canada M5B 2B8

Model and Serial Number section

Read this guide carefully.

It is intended to help you operate and maintain your new freezer properly. Keep it handy to answer your questions.

If you don't understand something or you need more assistance, please call:

1-800-4MY-HOME
(1-800-469-4663)

Write down the model and serial numbers.

You will find the serial number in two places: one is on the serial plate which is located on the back side of freezer, close to the top; the other one is located on the top right corner of packaging box right side.

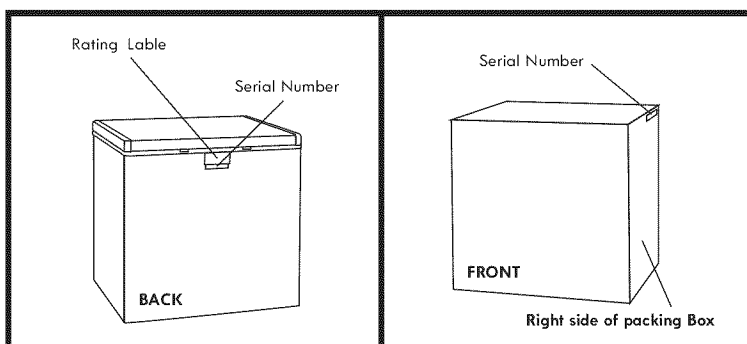

Please write these numbers here:

Model Number: 225.

Serial Number:

Use these numbers in any correspondence or service calls concerning your freezer.

If you received a damaged freezer, immediately contact Sears.

Save time and money. Before you call for service, check the Troubleshooting Guide. It lists causes of minor operating problems that you can correct yourself.

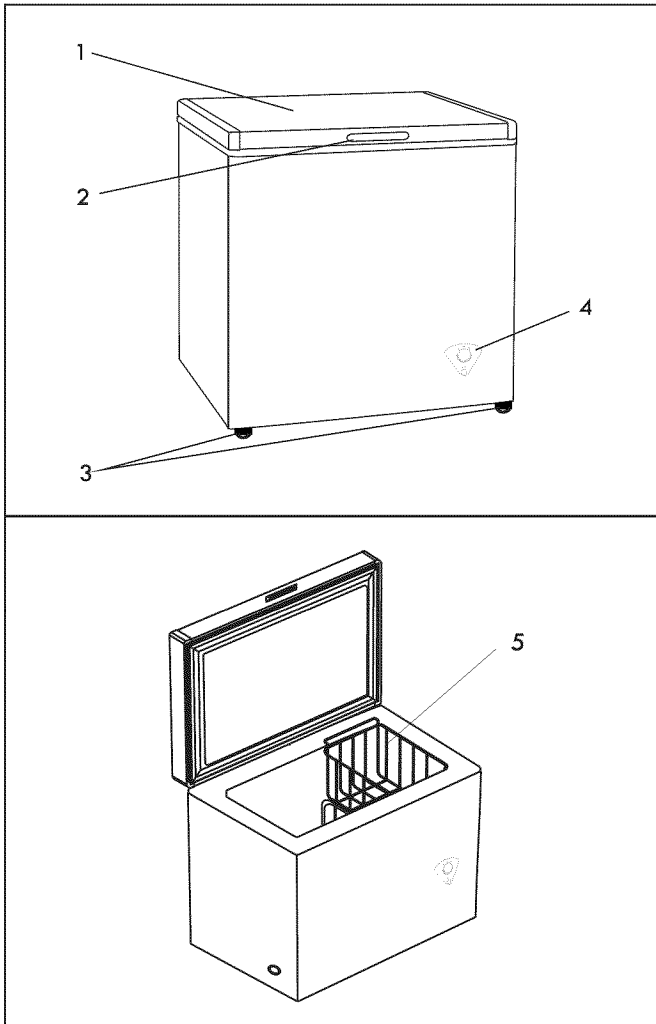

1. COUNTER BALANCED LID
2. RECESSED HANDLE
3. ROLLERS
4. THERMOSTAT CONTROL
5. BASKET



CHEST FREEZER SAFETY

Your safety and the safety of others are very important.

We have provided many important safety messages in this manual and on your appliance. Always read and obey all safety messages.



This is the Safety Alert Symbol. This symbol alerts you to potential hazards that can kill or injure you and others.

All safety messages will follow the Safety Alert Symbol and either the words "DANGER", "WARNING" or "CAUTION".



Danger means that failure to heed this safety statement may result in severe personal injury or death.



Warning means that failure to heed this safety statement may result in extensive product damage, serious personal injury, or death.



Caution means that failure to heed this safety statement may result in minor or moderate personal injury, or property or equipment damage.

All safety messages will alert you to what the potential hazard is, tell you how to reduce the chance of injury, and let you know what can happen if the instructions are not followed.



Before the freezer is used, it must be properly positioned and installed as described in this manual, so read the manual carefully. To reduce the risk of fire, electrical shock or injury when using the freezer, follow basic precautions, including the following:



- Plug into a grounded 3-prong outlet. Do not remove grounding prong, do not use an adapter, and do not use an extension cord. It is recommended that a separate circuit, serving only your freezer, be provided. Use receptacles that cannot be turned off by a switch or pull chain.
- Never clean freezer parts with flammable fluids. These fumes can create a fire hazard or explosion. And do not store or use gasoline or other flammable vapors and liquids in the vicinity of this or any other appliance. The fumes can create a fire hazard or explosion.
- Before proceeding with cleaning and maintenance operations, make sure the power cord is unplugged.
- Do not connect or disconnect the electric plug when your hands are wet.
- Do not attempt to repair or replace any part of your freezer unless it is specifically recommended in this Use&Care Guide. All other servicing should be referred to a qualified technician.
- If the unit is unplugged, lost power, or turned off; you must wait 3 to 5 minutes before restarting the unit. If you attempt to restart before this time delay, the freezer will not start.



IMPORTANT SAFETY INSTRUCTIONS

⚡ WARNING ⚡

To reduce the risk of fire, electrical shock, or injury when using your freezer, follow these basic precautions:

- Read all instructions before using the freezer.
- DANGER or WARNING: Risk of child entrapment.
- Before you throw away your old freezer: Take off the top. Leave the basket in place so that children may not easily climb inside.
 - Never allow children to operate, play with, or crawl inside the freezer.
 - Refrigerants: All refrigeration products contain refrigerants, which under the guidelines of federal law must be removed before disposal of product. It is the consumer's responsibility to comply with federal and local regulations when disposing of this product.
 - Never clean freezer parts with flammable fluids. The fumes can create a fire hazard or explosion.
 - Do not store or use gasoline or any other flammable vapors and liquids in the vicinity of this or any other freezer. The fumes can create a fire hazard or an explosion.

INSTALLATION INSTRUCTIONS

Before Using Your Freezer

Remove the exterior and interior packing.

Check to be sure you have all of the following parts:

- 1 Storage Basket
- 1 Divider
- 1 Use&Care Guide
- 1 Plastic Scraper

Before connecting the freezer to the power source, let it stand upright for approximately 2 hours. This will reduce the possibility of a malfunction in the cooling system from handling during transportation.

Clean the interior surface with lukewarm water using a soft cloth.

Installing Your Freezer

- This appliance is designed to be free standing only, and should not be recessed or built-in.
- Place your freezer on a floor that is strong enough to support the freezer when it is fully loaded.
- Allow 5.9 inches (15 cm) of space between the back and sides of the freezer, which allows for the proper air circulation.
- Locate the freezer away from direct sunlight and sources of heat (stove, heater, radiator, etc.). Direct sunlight may affect the acrylic coating and heat sources may increase electrical consumption. The recommended operating ambient temperature should be between 55°F (12.8°C) and 110°F (43.3)°C.
- Avoid locating the freezer in moist areas.
- Remove shipping material including base
Cut the packaging strap, then take off the packaging box and the interior protective plastic bag . Remove the protective foams off the freezer and put them inside the upended packaging box, uplift the freezer and remove the bottom protective pad under the freezer.
- After plugging the appliance into a wall outlet, allow the unit to cool down for 2~3 hours before placing food in the freezer.

Electrical Connection

WARNING

Improper use of the grounded plug can result in the risk of electrical shock. If the power cord is damaged, have it replaced by an authorized Avanti Products service center.

Plug the freezer into an exclusive, properly installed-grounded wall outlet. Do not under any circumstances cut or remove the third (ground) prong from the power cord. Any questions concerning power and/or grounding should be directed toward a certified electrician.



OPERATING YOUR FREEZER

Do not under any circumstances cut or remove the third ground prong from the power cord supplied.

This freezer requires a standard 115/120Volt~60Hz electrical outlet with three-prong ground.

The cord should be secured behind the freezer and not left exposed or dangling to prevent accidental injury.

Never unplug the freezer by pulling the power cord. Always grip the plug firmly and pull straight out from the receptacle.

Do not use an extension cord with this appliance. If the power cord is too short, have a qualified electrician or service technician install an outlet near the appliance.

Temperature Control

Your freezer has one control for regulating the temperature. The temperature control is located on the lower right hand corner.

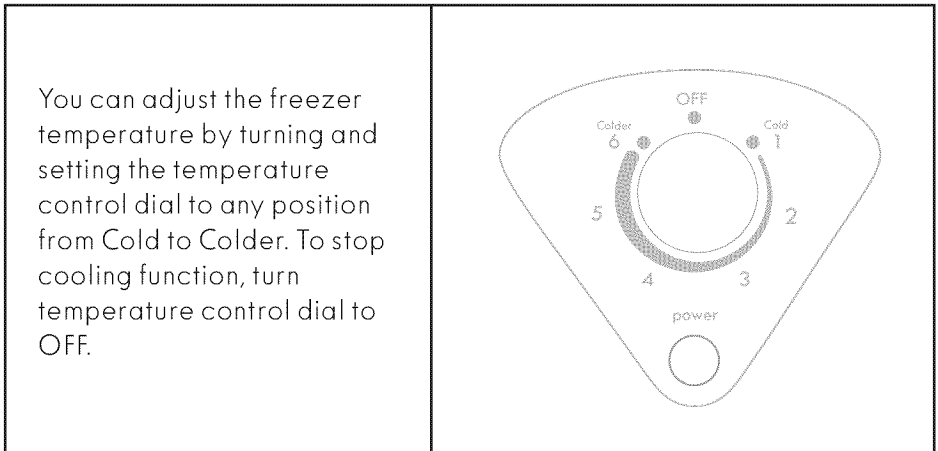

NOTE:

- Turning the temperature control to "OFF" position stops the cooling cycle but does not shut off the power to the freezer.
- Large amounts of food will lower the cooling efficiency of the freezer.
- If you choose to change the thermostat setting, adjust thermostat control by one numerical increment at a time. Allow several hours for temperature to stabilize between adjustments.

Defrosting Your Freezer

- For the most efficient operation and minimum energy consumption, defrost the freezer when the frost on the freezer walls is excessive ($\frac{1}{4}$ to $\frac{1}{2}$ inch thick).
- Choose a time when the stock of frozen food is low.

CAUTION

Do not use boiling water because it may damage the plastic parts. In addition, never use a sharp or metallic instrument to remove frost as it may damage the cooling coils and will void the warranty. We recommend using the plastic scraper provided with your unit.

- Remove the frozen food from the freezer and place it in a cooler to protect the food.
- Turn the thermostat knob to "OFF".
- Unplug the freezer. The Power Supply light should be off (green light out).
- During defrosting, the ice melts into the cabinet.
- Remove the drain plug on the inside floor of the freezer by pulling straight out.
- Place a shallow pan or drip tray outside drain outlet. The defrost water will drain out.

(See the diagram below)

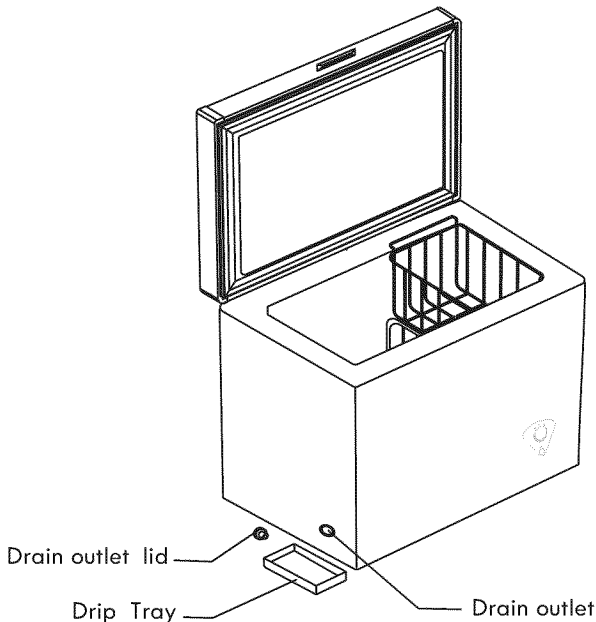



- Check the pan occasionally so the water does not overflow.
- Clean the interior of the freezer.
- Replace the plug on the inside floor.
- Plug in the electrical cord.
- Reset the thermostat to desired setting.
- Allow the cabinet to cool for one hour.
- Return food to the freezer.

HELPFUL HINT:

Defrosting usually takes a few hours. Leaving the door open will help speed the process. Also, pouring warm water (not boiling) on the ice/frost will help speed melting.

If you must use a scraper, be extremely careful, because it is very easy to damage the freezer compartment and void your warranty.

OPERATING YOUR FREEZER

The Freezer Compartment

- This compartment is designed for the long-term storage of frozen food.
- The storage life of frozen foods varies and the recommended storage time should not be exceeded. The instructions regarding the care of frozen foods should be followed when defrosting the freezer.
 - Pre-packed commercially frozen food should be stored in accordance with the frozen foods manufacturer's instructions for a three star frozen food storage compartment or home freezer.
 - Place frozen food into the freezer as quickly as possible after purchase. If there are instructions on the packet, carefully follow these instructions regarding storage times.
 - The freezer door is susceptible to breaking due to excessive ice build up. Be sure to defrost when the ice reaches $\frac{1}{4}$ to $\frac{1}{2}$ inch (5 to 10 mm) thick.
 - A storage basket is provided for the organization of odd-shaped items. To reach other packages in the freezer, just slide the basket to one side, or lift it out.



Cleaning Your Freezer

- Prior to installation of your new appliance, it is recommended that it be cleaned thoroughly.
- Turn the temperature control to "OFF", unplug the freezer, remove the food and storage basket.
- Wash the inside with a damp warm cloth containing a water and baking soda solution. The solution should be about 2 tablespoons of baking soda to a quart of water.
- Wash the storage basket with a mild detergent solution.
- Be sure to keep the door gasket (seal) clean to keep the unit running efficiently with warm water.
- The outside of the freezer should be cleaned with mild detergent and warm water.
- Dry the interior and exterior with a soft cloth.
- The condenser coils should be vacuumed when they are dusty or dirty.
- It is recommended that the unit be cleaned each time it is defrosted to help keep the unit odor free and running efficiently.

Vacation Time

- Remove all the food.
- Unplug the freezer.
- Clean the freezer.
- Leave the door open slightly to avoid possible formation of condensation, mold, or odors.
- Use extreme caution in the case of children. The unit should not be accessible to children's play.
- Short vacations: Leave the freezer operating during vacations of less than three weeks.
- Long vacations: If the appliance will not be used for several months, remove all food and unplug the power cord. Clean and dry the interior thoroughly. To prevent odor and mold growth, leave the door open slightly: blocking it open if necessary or have the door removed.

Moving Your Freezer

- Remove all the food.
- Securely tape down all loose items inside your freezer.
- Remove the rollers to prevent damage.
- Tape the doors shut.



Energy Saving Tips

- The freezer should be located in the coolest area of the room, away from heat producing appliances or heating ducts, and out of the direct sunlight.
- Let hot foods cool to room temperature before placing in the freezer. Overloading the freezer forces the compressor to run longer. Foods that freeze too slowly may lose quality, or spoil.
- Be sure to wrap foods properly, and wipe containers dry before placing them in the freezer. This cuts down on frost build-up inside the freezer.
- Freezer storage bin should not be lined with aluminum foil, wax paper, or paper toweling. Liners interfere with cold air circulation, making the freezer less efficient.
- Organize and label food to reduce door openings and extended searches. Remove as many items as needed at one time, and close the door as soon as possible.

TROUBLESHOOTING GUIDE



PROBLEM	POSSIBLE CAUSE
<p>Freezer does not operate</p>	<p>Not plugged in. The circuit breaker tripped or a blown fuse. The freezer temperature control is set at "OFF". If the unit is unplugged, lost power, or turned off; you must wait 3 to 5 minutes before restarting the unit. If you attempt to restart before this time delay, the freezer will not start.</p>
<p>Freezer exterior is warm</p>	<p>The exterior of the freezer may be as much as 30 degrees warmer than the ambient temperature. This is normal.</p>
<p>Compressor turns on and off frequently.</p>	<p>The room temperature is hotter than normal. A large amount of food has been added to the freezer. The door is open too often. The door is not closed completely. The temperature control is not set correctly. The door gasket does not seal properly. The freezer does not have the correct clearances. The freezer has recently been disconnected for a period of time. Four hours are required for the freezer to cool down completely.</p>
<p>Temperature inside the freezer is too warm</p>	<p>Temperature control is set too warm. Turn the control to a cooler setting and allow several hours for the temperature to stabilize. Door is kept open too long or is opened too frequently. Warm air enters the freezer every time the door is opened. Open the door less often. The door is not closed completely. The door gasket does not seal properly. A large amount of warm or hot food might have been stored recently. Wait until the freezer has had a chance to reach its selected temperature. The freezer has recently been disconnected</p>



TROUBLESHOOTING GUIDE

Temperature inside the freezer is too cold	Temperature control is set too cold. Turn the control to a warmer setting and allow several hours for the temperature to stabilize.
Popping or cracking sound when compressor comes on	Metal parts undergo expansion and contraction, as in hot water pipes. This is normal. Sound will level off or disappear as freezer continues to run.
Bubbling or gurgling sound, like water boiling	Refrigerant (used to cool freezer) is circulating throughout the system. This is normal.
Vibrations	Check to assure that the freezer is level. Floor is uneven or weak. Freezer rocks on the floor when it is moved slightly. Be sure floor can adequately support freezer. Level the freezer by putting wood or metal shims under part of the freezer. The freezer is touching the wall. Re-level the freezer and move it from the wall. See Installation Instructions .
Moisture forms on inside freezer walls.	Weather is hot and humid, which increases internal rate of frost build-up. This is normal. Door is slightly open. Door is kept open too long, or is opened too frequently. Open the door less often. The door is not sealed properly.
Moisture forms on outside of freezer	Door is slightly open, causing cold air from inside the freezer to meet warm moist air from outside.
The door will not close properly	The freezer is not level. The gasket is dirty. The storage basket is out of position.

MASTER PROTECTION AGREEMENTS



Congratulations on making a smart purchase. Your new Kenmore® product is designed and manufactured for years of dependable operation. But like all products, it may require preventive maintenance or repair from time to time. That's when having a Master Protection Agreement can save you money and aggravation. The Master Protection Agreement also helps extend the life of your new product.

Here's what the Agreement includes:

Parts and labor needed to help keep products operating properly **under normal use**, not just defects. Our coverage goes **well beyond the product warranty**. No deductibles, no functional failure excluded from coverage— **real protection**.

- ✔ **Expert service** by a force of more than **10,000 authorized Sears service technicians**, which means someone you can trust will be working on your product.
- ✔ **Unlimited service calls and nationwide service**, as often as you want us, whenever you want us.
- ✔ **“No-lemon” guarantee** – replacement of your covered product if four or more product failures occur within twelve months.
- ✔ **Product replacement** if your covered product can't be fixed.
- ✔ **Annual Preventive Maintenance Check** at your request – no extra charge.
- ✔ **Fast help by phone** – we call it **Rapid Resolution** – phone support from a Sears representative on all products. Think of us as a “talking owner's manual.”
- ✔ **Power surge protection** against electrical damage due to power fluctuations.
- ✔ **\$250 Food Loss Protection** annually for any food spoilage that is the result of mechanical failure of any covered refrigerator or freezer.
- ✔ **Rental reimbursement** if repair of your covered product takes longer than promised.
- ✔ **10% discount** off the regular price of any non-covered repair service and related installed parts.

Once you purchase the Agreement, a simple phone call is all that it takes for you to schedule service. You can call anytime day or night, or schedule a service appointment online.

The Master Protection Agreement is a risk free purchase. If you cancel for any reason during the product warranty period, we will provide a full refund. Or, a prorated refund anytime after the product warranty period expires. Purchase your Master Protection Agreement today!

Some limitations and exclusions apply. For prices and additional information in the U.S.A. call 1-800-827-6655.

Coverage in Canada varies on some items. For full details call Sears Canada at 1-800-361-6665.

Sears Installation Service

For Sears professional installation of home appliances, garage door openers, water heaters, and other major home items, in the U.S.A. or Canada call **1-800-4-MY-HOME®**.

Get it fixed, at your home or ours!

Your Home

For troubleshooting, product manuals and home solutions advice:

manage  home

www.managemyhome.com

For repair ? **in your home** ? of **all** major brand appliances, lawn and garden equipment, or heating and cooling systems, **no matter who made it, no matter who sold it!**

For the replacement parts, accessories and owner's manuals that you need to do-it-yourself.

For Sears professional installation of home appliances and items like garage door openers and water heaters.

1-800-4-MY-HOME (1-800-469-4663)

Call anytime, day or night (U.S.A. and Canada)

www.sears.com www.sears.ca

Our Home

For repair of carry-in items like vacuums, lawn equipment, and electronics, call anytime for the location of your nearest

Sears Parts & Repair Service Center

1-800-488-1222 (U.S.A.) **1-800-469-4663** (Canada)

www.sears.com

www.sears.ca

To purchase a protection agreement on a product serviced by Sears:

1-800-827-6655 (U.S.A.)

1-800-361-6665 (Canada)

Para pedir servicio de reparaci3n a domicilio, y para ordenar piezas:

1-888-SU-HOGAR

(1-888-784-6427)

Au Canada pour service en fran7ais:

1-800-LE-FOYER^{MC}

(1-800-533-6937)

www.sears.ca

Sears

?Registered Trademark / TM Trademark / SM Service Mark of Sears Brands, LLC

?Marca Registrada / TM Marca de F3brica / SM Marca de Servicio de Sears Brands, LLC

^{MC} Marque de commerce / ^{MD} Marque d'pose de Sears Brands, LLC

?Sears Brands, LLC

Free Manuals Download Website

<http://myh66.com>

<http://usermanuals.us>

<http://www.somanuals.com>

<http://www.4manuals.cc>

<http://www.manual-lib.com>

<http://www.404manual.com>

<http://www.luxmanual.com>

<http://aubethermostatmanual.com>

Golf course search by state

<http://golfingnear.com>

Email search by domain

<http://emailbydomain.com>

Auto manuals search

<http://auto.somanuals.com>

TV manuals search

<http://tv.somanuals.com>