

OWNER'S MANUAL

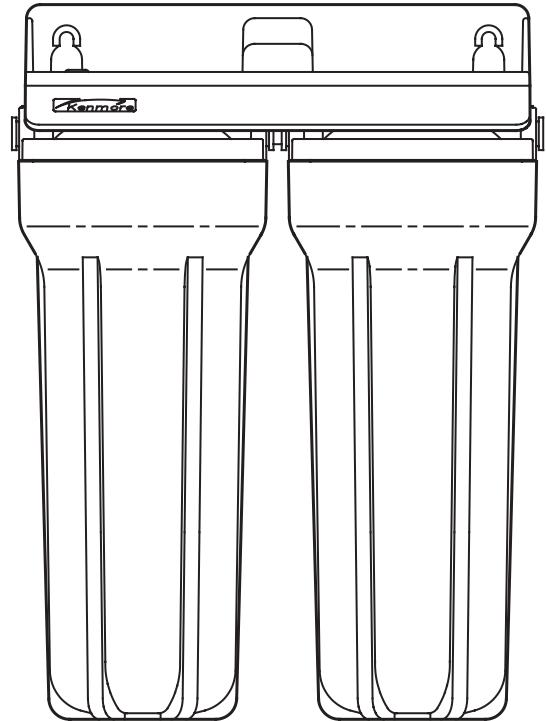

Two-Stage Drinking Water Filter

MODEL NO. 625.384610



Caution:

Read and follow all safety rules and operating instructions before first use of this product.

Questions ?

Visit www.KenmoreWater.com

or call toll free 1-800-426-9345 (M - F, 7 AM - 8 PM CST)

Repair or Parts ? Call toll free 1-800-469-4663

See back cover for other Sears service numbers.

SAVE THIS MANUAL

- Warranty
- Installation
- How It Works
- Care Of
- Specifications
- Repair Parts



System Tested and Certified by NSF International against NSF/ANSI Standard 42. See performance data sheet for details.

Sears, Roebuck and Co., 3333 Beverly Road, Hoffman Estates, IL 60179 U.S.A.

Warranty

ONE YEAR FULL WARRANTY ON THE TWO-STAGE DRINKING WATER FILTER

When installed, operated and maintained according to all instructions supplied with the product, if this Two-Stage Drinking Water Filter fails due to a defect in material or workmanship within one year from the date of purchase, call 1-800-4-MY-HOME to arrange for free repair (or replacement if repair proves impossible). This warranty does not include filter cartridges, which are expendable items.

This warranty applies only while this product is in use in the United States or Canada.

This warranty gives you specific legal rights, and you may have other rights which vary from state to state.

Sears, Roebuck and Co., Hoffman Estates, IL 60179

Dimensions

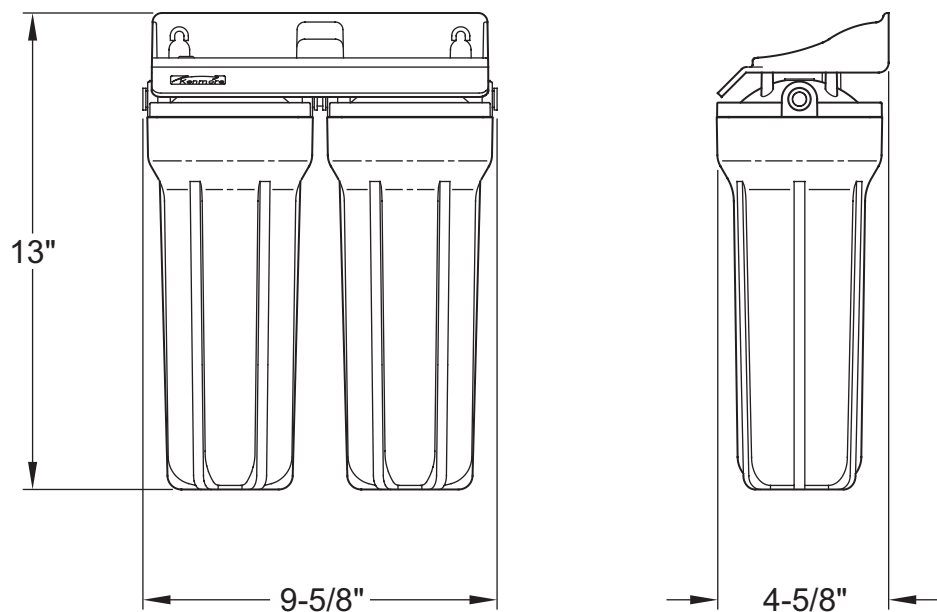

Questions? Call The Kenmore Water Line 1-800-426-9345 or visit KenmoreWater.com

Table of Contents

Unpack and Check Shipment	4
Plan Your Installation	5
Step 1-Install Supply Water Fitting	6
Step 2-Install Filtered Water Faucet	7
Step 3-Connect Tubes	8
Maintenance	9-11
Specifications	12
Troubleshooting	12
Exploded View & Parts List	14-15

Safety Guides

- ▼ Read all steps and guides carefully before installing and using your Two-Stage Drinking Water Filter. Follow all steps exactly to correctly install. Reading this manual will also help you to get all the benefits from the Two-Stage Drinking Water Filter.
- ▼ Do not attempt to use this product to make safe drinking water from non-potable water sources. Do not use the system on microbiologically unsafe water, or water of unknown quality without adequate disinfection before or after the system.
- ▼ Check with your local public works department for plumbing and sanitation codes. You must follow their guides as you install the system. Follow your local codes if they differ with guides in this manual. In Massachusetts, plumbing codes of Massachusetts shall be adhered to. Consult with a licensed plumber.
- ▼ The Two-Stage Drinking Water Filter works on water pressures of 30 psi (minimum) to 100 psi (maximum). If your house water pressure is over the maximum, install a pressure reducing valve in the water supply pipe to the Two-Stage Drinking Water Filter.
- ▼ Do not install the Two-Stage Drinking Water Filter outside, or in extreme hot or cold temperatures. Temperature of the water supply to the Two-Stage Drinking Water Filter must be between 40°F and 100°F. Do not install on hot water.

Questions? Call The Kenmore Water Line 1-800-426-9345 or visit KenmoreWater.com

Unpack and Check Your Carton

INSPECT SHIPMENT

Your Two-Stage Drinking Water Filter is shipped complete in one carton. Remove all items from your shipping carton.

Check all items against the packing list below. Note any items lost or damaged in shipment. Note any damage to the shipping carton. Refer to the exploded view and parts list in the back of the manual for the part names and numbers of missing or damaged items. If problems exist, refer to the website or the toll free number listed throughout this manual.

Keep the small parts in the parts bag until you are ready to install them.

NOTE: Codes in the state of Massachusetts require installation by a licensed plumber.

If you live in the state of Massachusetts, review plumbing code 248-CMR of the Commonwealth of Massachusetts before proceeding with the installation.

Packing List

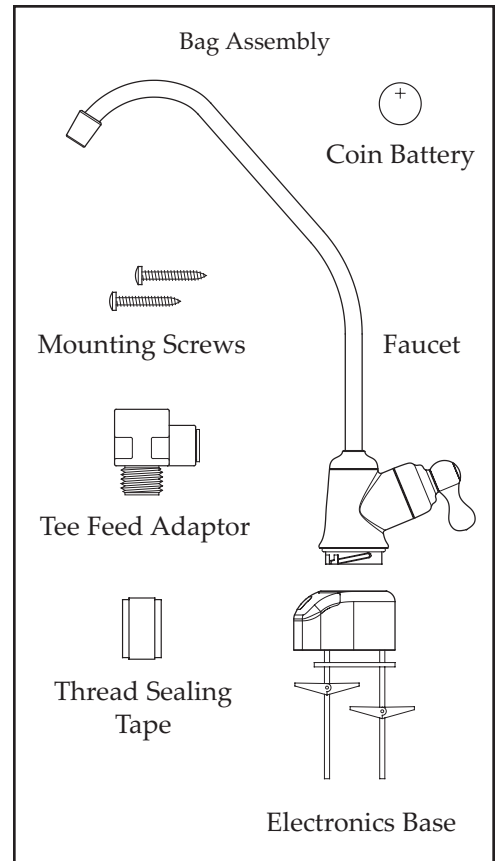
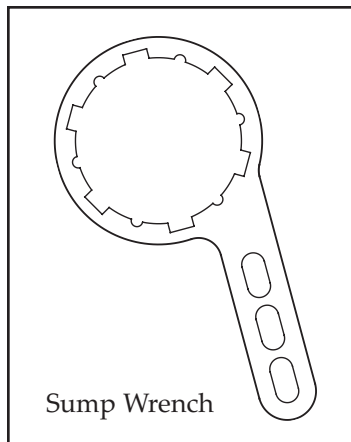
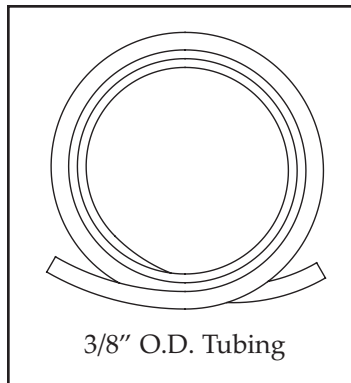
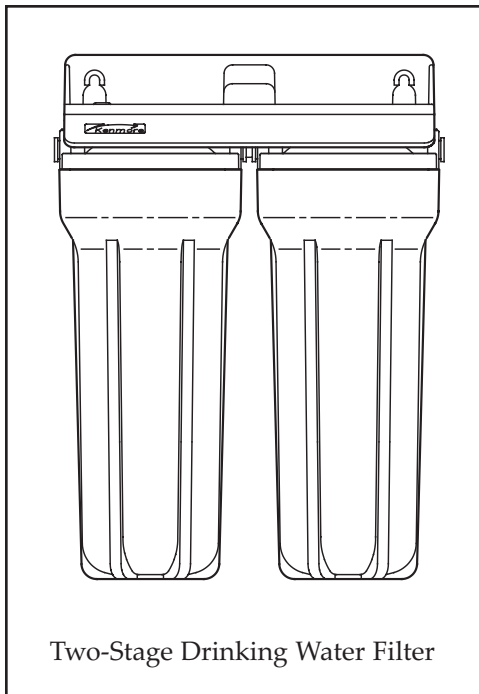

Questions? Call The Kenmore Water Line 1-800-426-9345 or visit KenmoreWater.com

Plan Your Installation

PLAN YOUR INSTALLATION

It is recommended to read through the entire manual before beginning your installation. Follow all steps exactly. Reading this manual will also help you get all the benefits from your system.

TYPICAL UNDER SINK LOCATION

The Two-Stage Drinking Water Filter housing is normally located under the kitchen and/or bathroom sink, to filter the cold drinking water. See Figure 2.

CHECK SPACE REQUIREMENTS

Check size and position of items for proper installation into location chosen.

TOOLS NEEDED

Review the tools needed list. See Figure 1. Gather needed tools before proceeding with the installation. Read and follow the instructions provided with any tools listed here.

IMPORTANT: A 1-1/4" dia. hole is needed to mount the filtered water faucet. To avoid damaging the sink, consult a qualified plumber or installer for drilling procedures in porcelain or stainless steel.

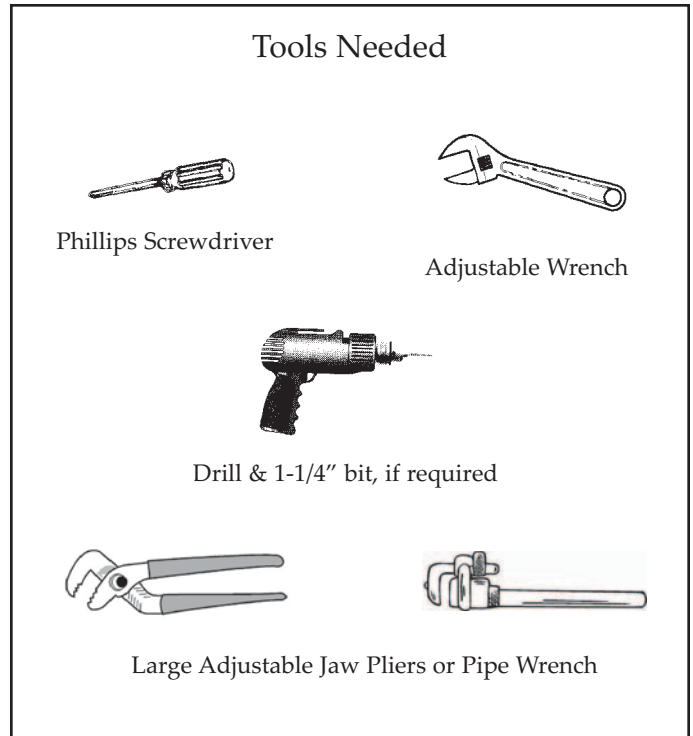
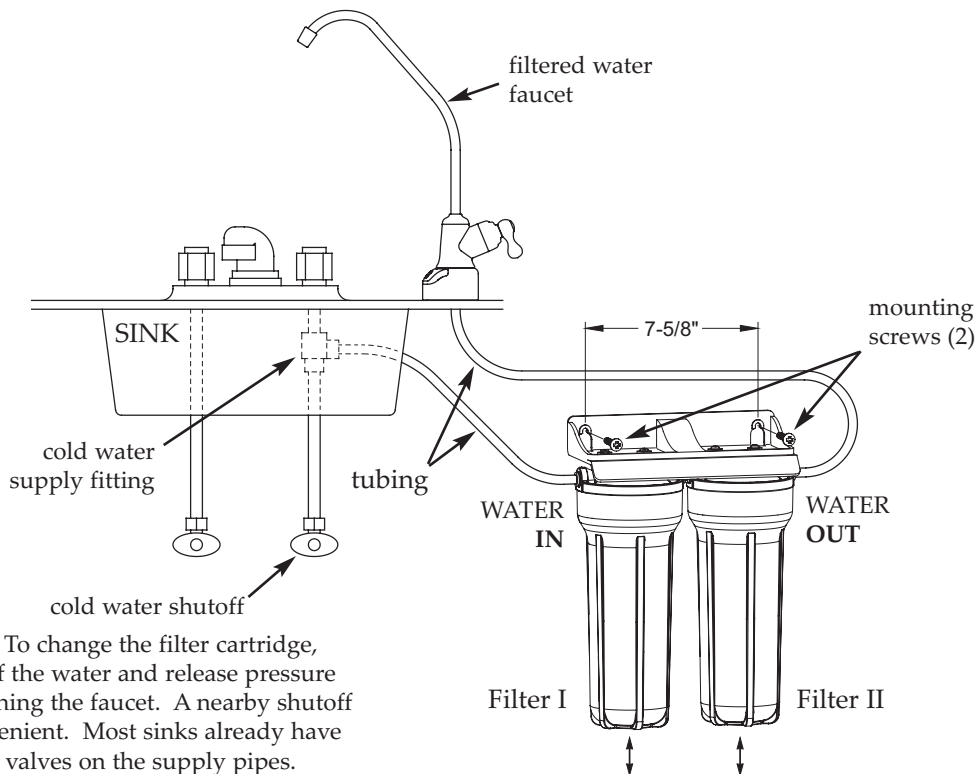

Figure 1

Typical Under Sink Installation



NOTE: Allow a minimum space of 1-1/2" under the system for removing the sumps (to change cartridges).

Figure 2

Questions? Call The Kenmore Water Line 1-800-426-9345 or visit KenmoreWater.com

Step 1 - Install Water Supply Fitting

CHOOSE TYPE OF WATER SUPPLY FITTING TO INSTALL

Locate the cold water line in the sink cabinet. Check and comply with local plumbing codes as you plan, and then install a water supply fitting on the sink's cold water line. The fitting must provide a leak-tight connection to the Two-Stage Drinking Water Filter's 3/8" O.D. inlet tubing. A typical connection using the included water supply fitting is shown in Fig. 3. An alternative connection using standard plumbing fittings (not included) is shown in Fig. 4.

NOTE: Local code may dictate which type of water fitting is used. Consult a plumber if you are not familiar with local codes or plumbing procedures.

NOTE: Codes in the state of Massachusetts require installation by a licensed plumber.

If you live in the state of Massachusetts, review plumbing code 248-CMR of the Commonwealth of Massachusetts before proceeding with the installation.

A. WATER SUPPLY CONNECTION USING INCLUDED FITTING

1. Close the house main water shutoff valve and open faucets to drain water from the sink's cold water pipe.
2. Remove the nut that connects the cold water faucet to cold water plumbing.
3. Thread the included water supply fitting onto the pipe and reconnect nut to bottom of fitting.

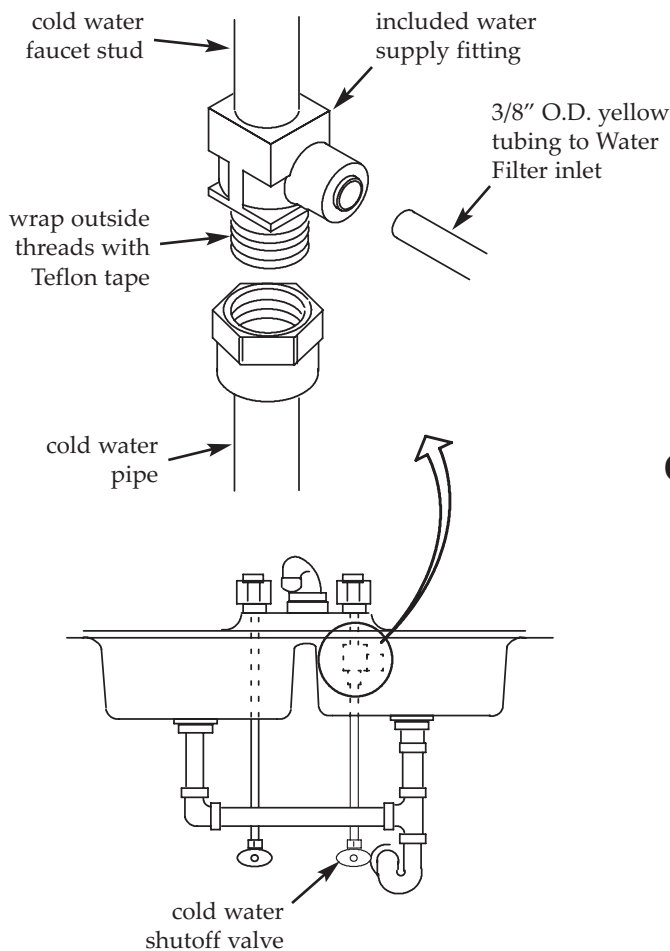

Figure 3

B. WATER SUPPLY TYPICAL CONNECTION USING COMPRESSION TYPE FITTING (PARTS NOT INCLUDED)

NOTE: Before starting, be sure to turn off water supply and open a low faucet to drain the pipe.

Complying with plumbing codes, install a fitting on the cold water pipe to adapt to 3/8" O.D. tubing. A typical connection is shown in Figure 4. If threaded fittings are used, be sure to use pipe joint compound or Teflon tape on outside threads.

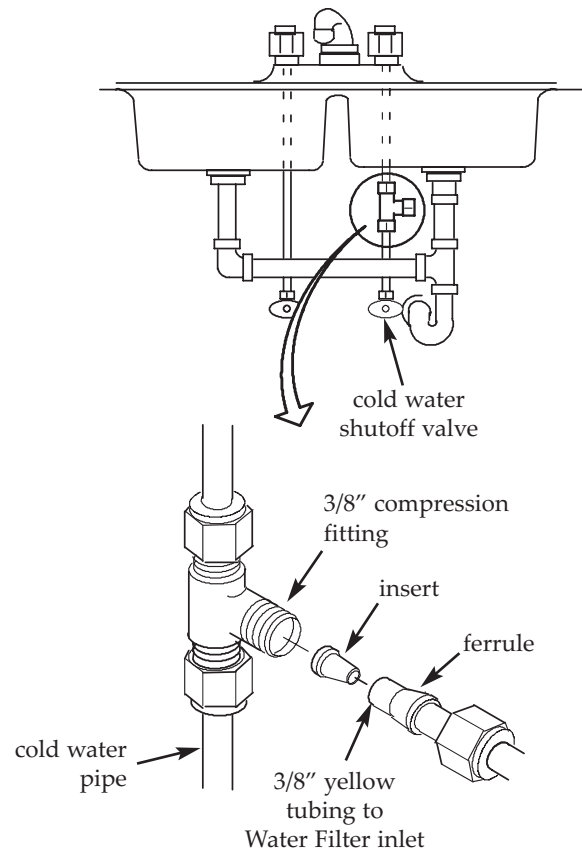

Figure 4

OR

Questions? Call The Kenmore Water Line 1-800-426-9345 or visit KenmoreWater.com

Step 2 - Install Filtered Water Faucet

MAKE HOLE FOR FAUCET

IMPORTANT: A 1-1/4" dia. hole is needed to mount the filtered water faucet. To avoid damaging the sink, consult a qualified plumber or installer for drilling procedures in porcelain or stainless steel.

1. Select one of the following options to install the faucet. Make sure there is room underneath to make the needed connections.
 - Use an existing sink top hole for spray hose or soap dispenser (must be 1-1/4" in diameter).
 - Drill a new hole in the sink top.
 - Drill a hole in the countertop next to the sink.
2. Check to make sure the filtered water faucet base will sit flat against the mounting surface.
3. If drilling is needed, make a 1-1/4" dia. (minimum) hole for the faucet in the mounting surface.

INSTALL FAUCET BASE

1. Locate the faucet base (See Fig. 5) and feed the toggle bolts down through the hole until the faucet base is square against the mounting surface (sink or countertop). The rubber gasket should be between the faucet base and mounting surface.
2. Tighten the toggle bolts until the faucet base is firmly mounted to the surface. Do not overtighten.

CONNECT TUBE TO FAUCET

1. Mount the Two-Stage Drinking Water Filter assembly under the sink. Allow a minimum of 1-1/2" under the sumps for changing cartridges (See Fig. 2 on Page 5).
2. Locate the 3/8" O.D. tubing. Refer to the "Connect Tubes" section on Page 8 and insert one end of the tube all the way into the 3/8" quick connect fitting on the water OUT side of the filter assembly. See Figure 6.
3. Feed the other end of the tubing up through the mounting hole and faucet base. See Figure 6.
4. Refer to the "Cut Tubes to Length" section on Page 8 and cut the tube square and to length as needed, leaving about 6 inches above the faucet base.
5. Locate the faucet. Refer to the "Connect Tubes" section on Page 8 and insert the tube all the way into the 3/8" quick connect fitting on the faucet bottom.
6. Pull on the tube at each end to be sure it is held firmly in both of the quick connect fittings.

INSTALL FAUCET ON BASE

1. Lower the faucet onto the base. See Figure 7.
2. Give the faucet a 1/4 turn clockwise to attach the faucet to the base.
3. Install battery in faucet base (See "Change Battery" section on Page 9) then continue installation with Step 3 on Page 8.

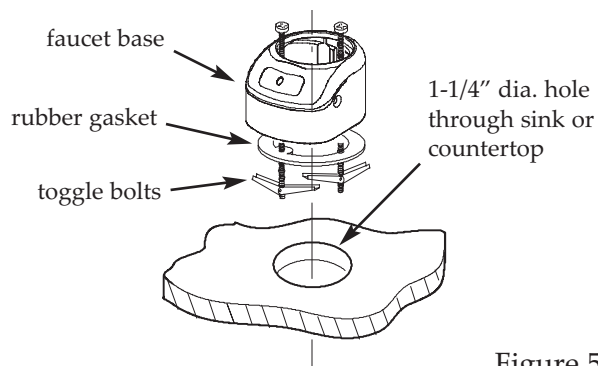

Figure 5

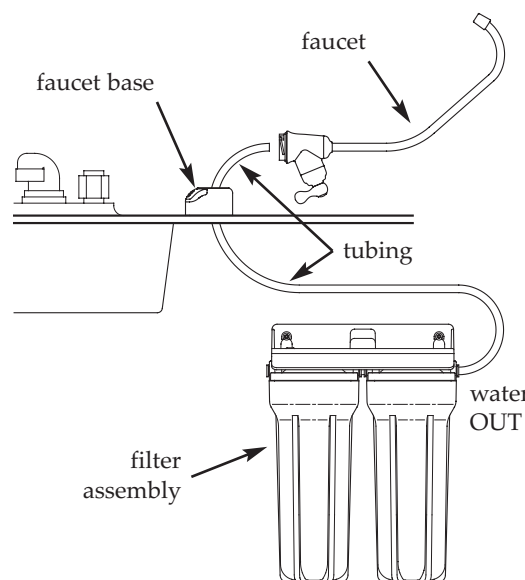

Figure 6

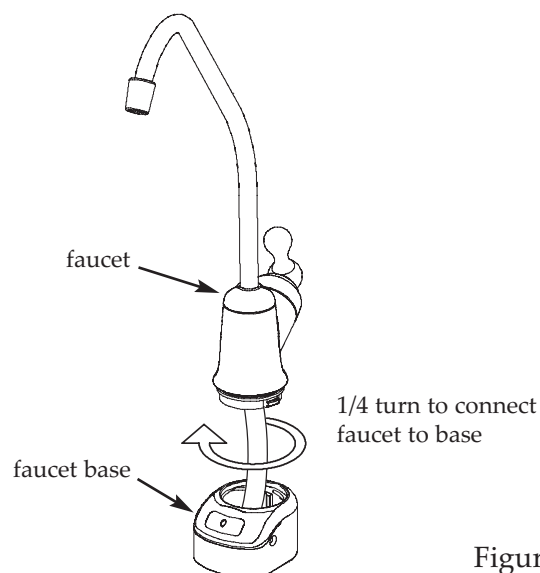

Figure 7

Questions? Call The Kenmore Water Line 1-800-426-9345 or visit KenmoreWater.com

Step 3 - Connect Tubes

CONNECT TUBE TO WATER SUPPLY FITTING

1. Locate the remaining piece of 3/8" O.D. tubing. Refer to the "Connect Tubes" section, below, and insert one end of the tube all the way into the 3/8" quick connect fitting on the water IN side of the filter assembly. See Figure 8.
2. Run the other end to the water supply fitting on the cold water pipe. See Figure 8. Refer to the "Cut Tubes to Length" section, below, and cut the tube square and to length as needed.
3. Refer to the "Connect Tubes" section, below, and insert the tube all the way into the 3/8" quick connect fitting on included water supply fitting (installed in Step 1).
4. Pull on the tube at each end to be sure it is held firmly in both of the quick connect fittings.

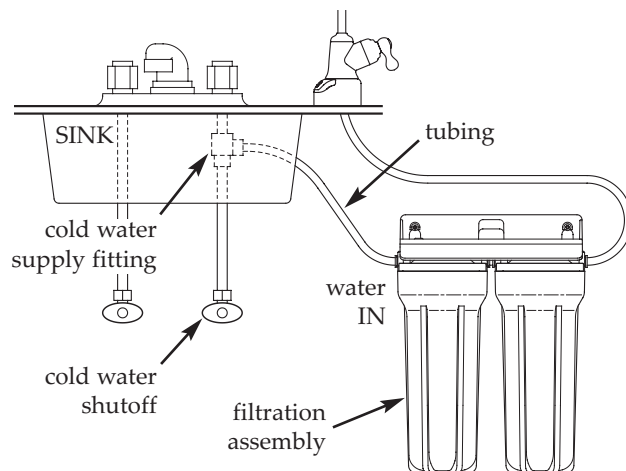

Figure 8

HOW TO CUT AND CONNECT THE TUBES

Your Two-Stage Drinking Water Filter includes push-in fittings for quick tubing connection. Review the following instructions before connecting the tubes.

Cut tubes to length

1. Use a sharp cutter or knife to cut the end of tubing. Always cut the tubing square. See Figure 9.
2. Inspect the end (about 1") of the tubing to be sure there are no nicks, scratches or other rough spots. If needed, cut the tubing again.

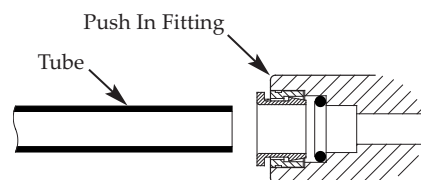

Cut tubing square with end of tubing round, smooth, with no cuts, nicks or flat spots.

Tube Correctly Cut

Figure 9

Connect tubes

1. Push tubing through collet, until it engages the o-ring. See Figure 10. Continue pushing until the tube bottoms out against the back of the fitting. See Figure 11. A common mistake is to stop pushing when the tube engages the o-ring. This will lead to future leaks. When a 3/8" tube is fully engaged, 3/4" of the tube has entered the fitting. See Figures 10 & 11.
2. If using tubing other than tubing supplied with the system, be sure it is of high quality, exact size and roundness with a smooth surface.

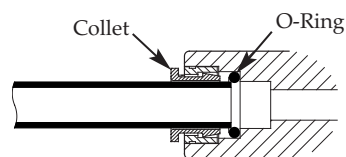

Tube Partially Engaged With Fitting

Figure 10

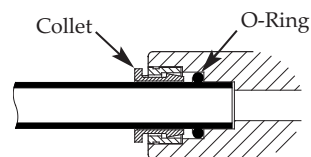

Tube Fully Engaged With Fitting

Figure 11

Disconnect Tubes

1. Push the collet inward with a finger tip. See Figure 12.
2. Continue holding collet inward while pulling the tubing out. See Figure 13.

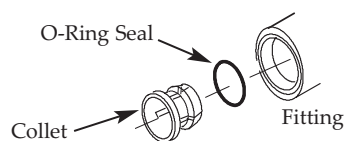

Collet and O-Ring

Figure 13

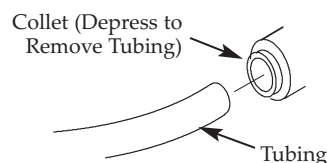

Disconnect Tubing

Figure 12

Questions? Call The Kenmore Water Line 1-800-426-9345 or visit KenmoreWater.com

Maintenance

FAUCET ELECTRONICS

Inside the faucet base is a battery operated 6 month timer. See Figure 14.

An amber LED indicator is also located in the front of the faucet base. This LED will flash continuously after 6 months has passed. This indicates that it is time to replace the battery and filter cartridges.

CHANGE BATTERY

To change (or install) the battery, complete the following steps.

1. Loosen the screw on the right side of the faucet base
See Figure 14.
2. Press the battery housing upwards from the front faucet base until it releases from the faucet base. See Figure 14.
3. Replace (or install) the battery (Maxell CR 2032 or equivalent). Place battery into the holder with the positive (+) side facing the back of the holder.
4. When the battery is first replaced it will flash six times and turn off. This indicates the battery is fully charged. After the six flashes, the timer enters the 6 month time cycle.

NOTE: If the LED repeatedly flashes just two times, it is not a fully charged battery and will need to be replaced.

5. Re-install the timer housing and firmly tighten the mounting screw. See Figure 14.

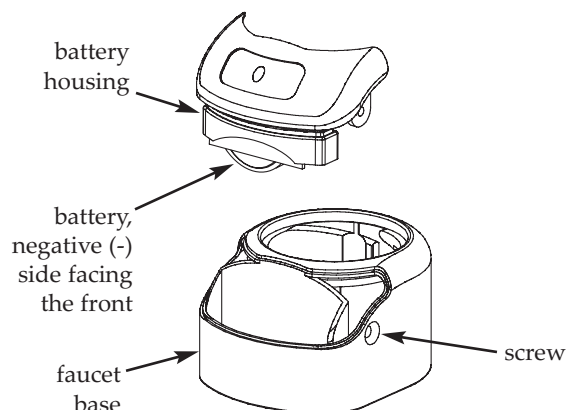

Figure 14

Maintenance

FILTER CARTRIDGE LIFE

It is recommended to replace the battery and filter cartridges every 6 months of use. There are several variables that determine how long a cartridge will last. These include:

1. How much water you use, and
2. How much sediment, taste and/or odor, or other unwanted substances, are in the water.

Use the following information as a guide. However no matter which type of cartridge you are using, you will know it is time to replace it when you first notice the return of unwanted substances in your water.

Kenmore Two-Stage Drinking Water Filter model 625.384610 with replacement cartridges 42-38480 (Sediment, 5 Micron)* and 42-34373 (Taste & Odor, Premium) has been tested and certified by NSF international for the reduction of chlorine taste and odor. The rated capacity for this system is 4,500 gallons (17,034 liters) at a rated service flow of 0.6 gpm (gallons per minute).

OPTIONAL CARTRIDGES

Other filter cartridges are available from Sears to reduce sediments, tastes and odors, and chemical contaminants. Following is a list of filter cartridges available:

Sediment Filter Cartridge, 25 Micron*: Sediment cartridges reduce sand, silt, clay, dirt and other sediments from water. Sears Item No. 42-38478 filters the larger sediments from water, and allows higher flows at less pressure drop.

Taste and Odor Cartridges: Many bad tastes and/or odors are reduced from water by an activated carbon cartridge. It is most often used to reduce chlorine taste and smell, usually to a single faucet such as the kitchen cold.

NOTE: Small amounts of hydrogen sulfide (noticeable as "rotten egg" odor) may be reduced by taste and odor filters for a short time, quickly exhausting the carbon media. Consult your Sears store for proper continuous treatment.

Sears Item No. 42-34370**:

For reduction of chlorine taste and odor.

Sears Item No. 42-34365*:

For 99% chlorine reduction, plus reduction of chemical contaminants.

Sears Item No.42-34377**:

For reduction of lead, cysts, and chlorine taste and odor.

* These cartridges have not been performance tested and certified by NSF International.

** These cartridges have been performance tested and certified by NSF International in Model 625.384600.

Questions? Call The Kenmore Water Line 1-800-426-9345 or visit KenmoreWater.com

Maintenance

FILTER CARTRIDGE REPLACEMENT

Complete the following steps to replace the cartridges:

CAUTION: Never remove sumps with water pressure in the filter system.

1. Close the water supply shutoff valve (See Fig. 2 on Page 5) to the filter. Open the filtered water faucet to relieve pressure in the system.
2. Use the sump removal wrench, included, to turn the sump to the left to loosen it from the filter head. Be careful - the sump is full of water. Do not lose the large o-ring seal.
3. Dispose of the old cartridge in a proper manner.
4. Make sure the inside of the sump is clean. Use hot, soapy water and rinse thoroughly.
5. Remove the wrapper from the new cartridge and insert filter cartridge into the sump. Some cartridges fit either way, while others fit only one way. Observe markings on the cartridge or wrapper.

NOTE: If you are using filter numbers 42-38480 and 42-34373, place filter 42-38480 (Sediment*) in the Filter I position and place filter 42-34373 (Taste & Odor) in the Filter II position (See Fig. 15).

6. Lightly lubricate the o-ring seal in the sump with silicone grease. Be sure it is fully seated in its groove.

7. Hold the sump up to the filter head, aligning the center hole in the cartridge with the protrusion on the bottom of the head.

NOTE: If the sump will not tighten up to the head, and you are using cartridges other than 42-38480 and 42-34373, you may have the cartridge in upside down. Take the cartridge out and check for correct orientation.

8. Being careful not to cross-thread, turn the sump to the right onto the filter head and tighten securely.
9. Repeat steps 2 through 8 for the other filter.
10. Open the filtered water faucet. Then, slowly open the water supply valve and allow the filter housing to fill.
11. Close the filtered water faucet. Check for leaks between the sumps and the heads.
12. Remove and replace the timer battery. See "Change Battery" on Page 9.

Taste and Odor Cartridges: A taste and odor cartridge contains activated carbon, a black powder. When new, open the filtered water faucet and allow fine carbon particles to purge from the cartridge. Close the faucet when you no longer see the "fines" (carbon particulates) in the filtered water, or approximately 10 minutes.

* This cartridge has not been performance tested and certified by NSF International.

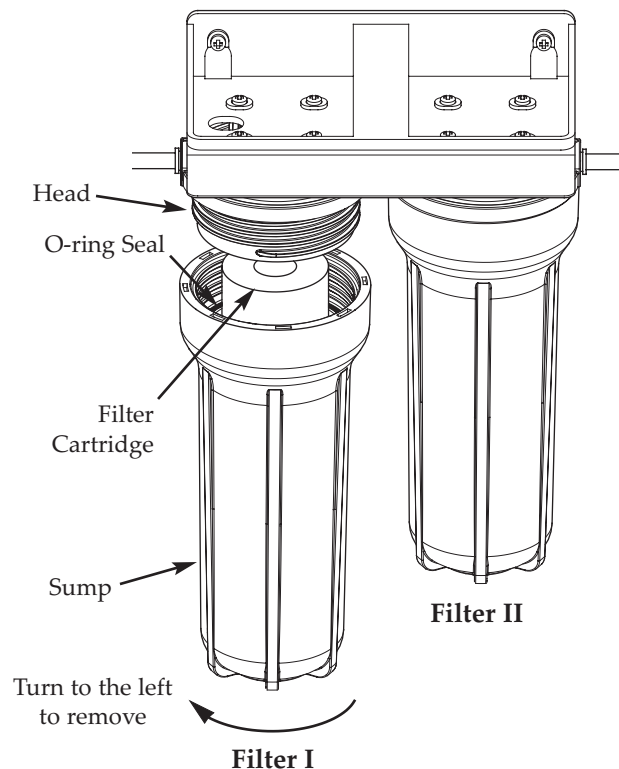

Figure 15

Questions? Call The Kenmore Water Line 1-800-426-9345 or visit KenmoreWater.com

Specifications

Supply water pressure limits30-100 psi (207-689 kPa)
 Supply water temperature limits40-100 °F (5-40 °C)
 Inlet - Outlet3/8" Quick Connect fittings & tubing, included

This system conforms to NSF/ANSI 42 for the specific performance claims as verified and substantiated by test data.

Installations In The Commonwealth Of Massachusetts: The Commonwealth of Massachusetts requires installation be performed by a licensed plumber. Plumbing code 248--CMR of the Commonwealth of Massachusetts must be followed in these cases.

Troubleshooting

Problem: Taste and/or Odor.	
Cause: Filter cartridges expended.	Correction: Replace the filter cartridges. See Pages 10 & 11.
Cause: System contaminated.	Correction: Sanitize system. Call 1-800-426-9345 for instructions.
Problem: Faucet LED indicator light does not function after battery change.	
Cause: Battery dead.	Correction: Replace with new battery. See Page 9.
Cause: Battery installed incorrectly..	Correction: Install battery correctly.
Problem: Water leaks at push connect fittings.	
Cause: Tubing not pushed in all the way.	Correction: Push Tubing all the way into fittings. See Page 8.
Cause: Tubing not cut square.	Correction: Cut tubing square. See Page 8.
Cause: Tubing nicked.	Correction: Remove tube from connection. Remove nicked portion by cutting tube to shorter length. Reinsert in connection See Page 8.
Cause: Outer tubing surface not smooth.	Correction: Remove tube from connection. Remove problem area by cutting tube to shorter length. Reinsert in connection See Page 8.

Questions? Call The Kenmore Water Line 1-800-426-9345 or visit KenmoreWater.com

Notes

Questions? Call The Kenmore Water Line 1-800-426-9345 or visit KenmoreWater.com

Exploded View

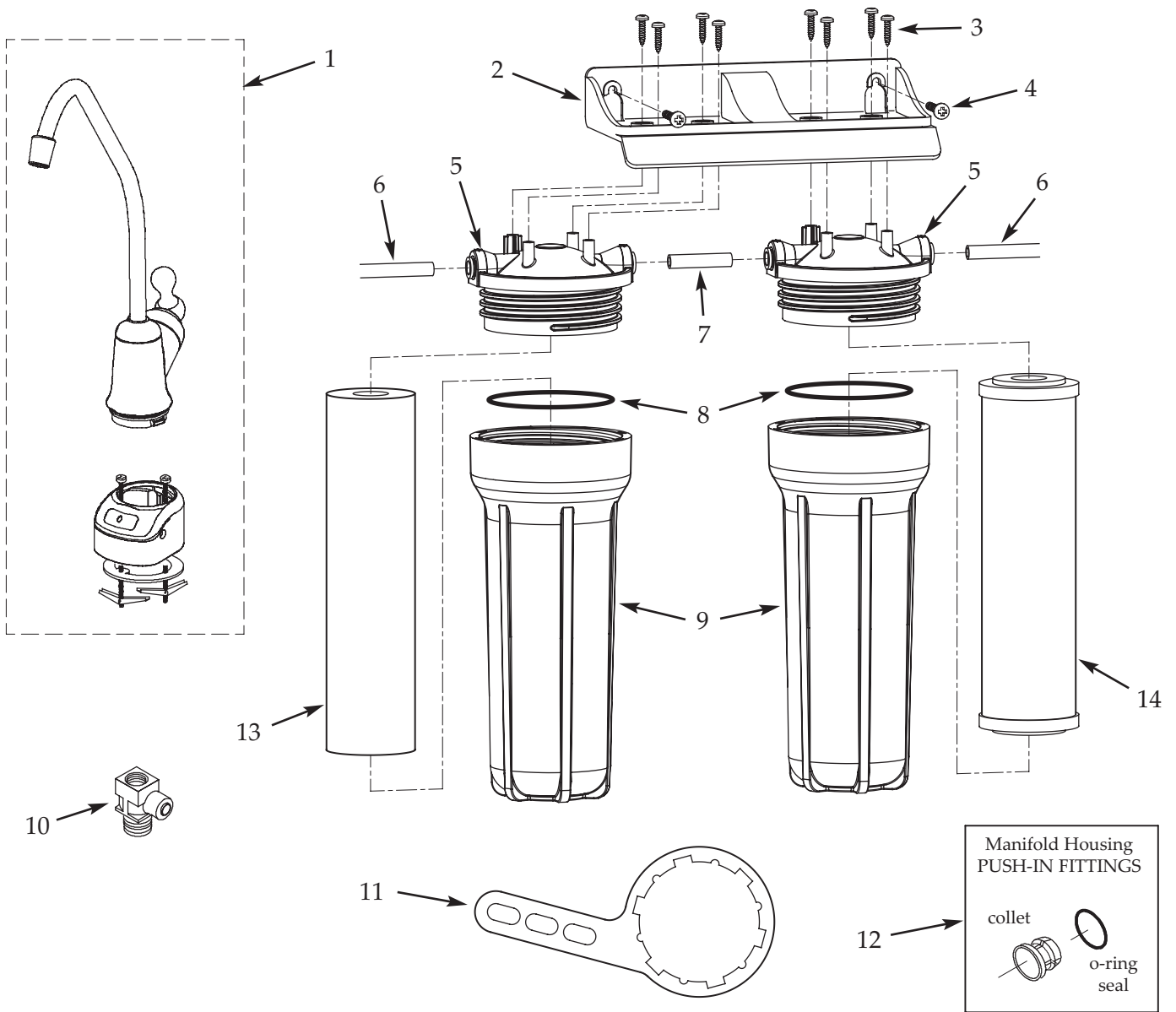

Questions? Call The Kenmore Water Line 1-800-426-9345 or visit KenmoreWater.com

Repair Parts List

Key No.	Part No.	Description
1	7292674	Faucet, with base & electronics
2	7293793	Mounting Bracket
3	7160453	Screw, #10-12 x 3/4" (8 req.)
4	9006053	Screw, #10-16 AB (2 req.)
5	7256864	Head (2 req.)
6	7168435	Tubing, 3/8" O.D. x 72" long, White
7	7279040	Tube, 3/8" O.D. x 1.78" long, White
8	7170246	O-ring, 3-3/8" I.D. x 3-5/8" O.D. (2 req.)
9	7205596	Sump (2 req.)
10	7228536	Tee Feed Adaptor
11	7193066	Wrench, Sump Removal
12	7209574	Push-in Fitting Kit, 3/8" ◆
■	7154818	Coin Battery
■	7293858	Owner's Manual
13	42-38480	Sediment Cartridge, 5 micron ●
14	42-34373	Taste & Odor Cartridge, Premium
*	42-38478	Sediment Cartridge, 25 micron ●
*	42-34370	Taste & Odor Cartridge ○
*	42-34365	Taste & Odor / Chemical Contaminant Cartridge ●
*	42-34377	Taste & Odor / Lead Cartridge ○

- ◆ O-ring and collet kit for replacement in the head only. Not included.
- Not illustrated.
- * Optional replacement cartridges available at your local Sears store, online at www.sears.com or from Sears Parts at 1-800-469-4663. Not included.
- These cartridges have not been performance tested and certified by NSF International.
- These cartridges have been performance tested and certified by NSF International in Model 625.384600.

Questions? Call The Kenmore Water Line 1-800-426-9345 or visit KenmoreWater.com

Get it fixed, at your home or ours!

Your Home

For repair – **in your home** – of **all** major brand appliances, lawn and garden equipment, or heating and cooling systems, **no matter who made it, no matter who sold it!**

For the replacement parts, accessories and owner's manuals that you need to do-it-yourself.

For Sears professional installation of home appliances and items like garage door openers and water heaters.

1-800-4-MY-HOME[®] (1-800-469-4663)

Call anytime, day or night (U.S.A. and Canada)

www.sears.com www.sears.ca

For expert home solutions advice: www.managemyhome.com

Our Home

For repair of carry-in items like vacuums, lawn equipment, and electronics, call or go on-line for the location of your nearest

Sears Parts & Repair Service Center

1-800-488-1222 (U.S.A.) **1-800-469-4663** (Canada)

Call anytime, day or night

www.sears.com www.sears.ca

To purchase a protection agreement on a product serviced by Sears:

1-800-827-6655 (U.S.A.)

1-800-361-6665 (Canada)

Para pedir servicio de reparación a domicilio, y para ordenar piezas:

1-888-SU-HOGAR[®]

(1-888-784-6427)

Au Canada pour service en français:

1-800-LE-FOYER^{MC}

(1-800-533-6937)

www.sears.ca



Free Manuals Download Website

<http://myh66.com>

<http://usermanuals.us>

<http://www.somanuals.com>

<http://www.4manuals.cc>

<http://www.manual-lib.com>

<http://www.404manual.com>

<http://www.luxmanual.com>

<http://aubethermostatmanual.com>

Golf course search by state

<http://golfingnear.com>

Email search by domain

<http://emailbydomain.com>

Auto manuals search

<http://auto.somanuals.com>

TV manuals search

<http://tv.somanuals.com>