

KENWOOD

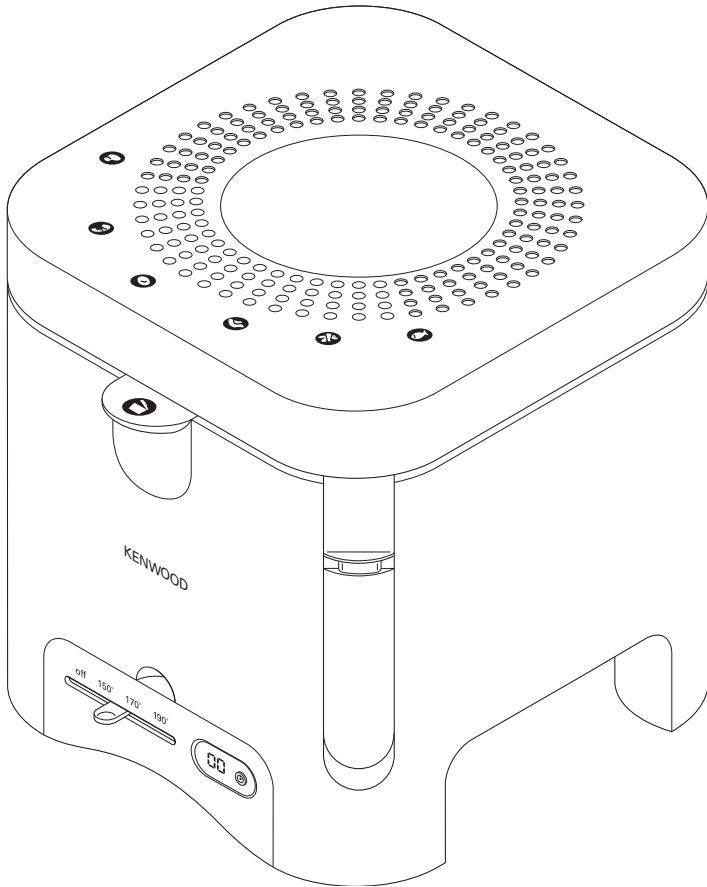

DF520 series

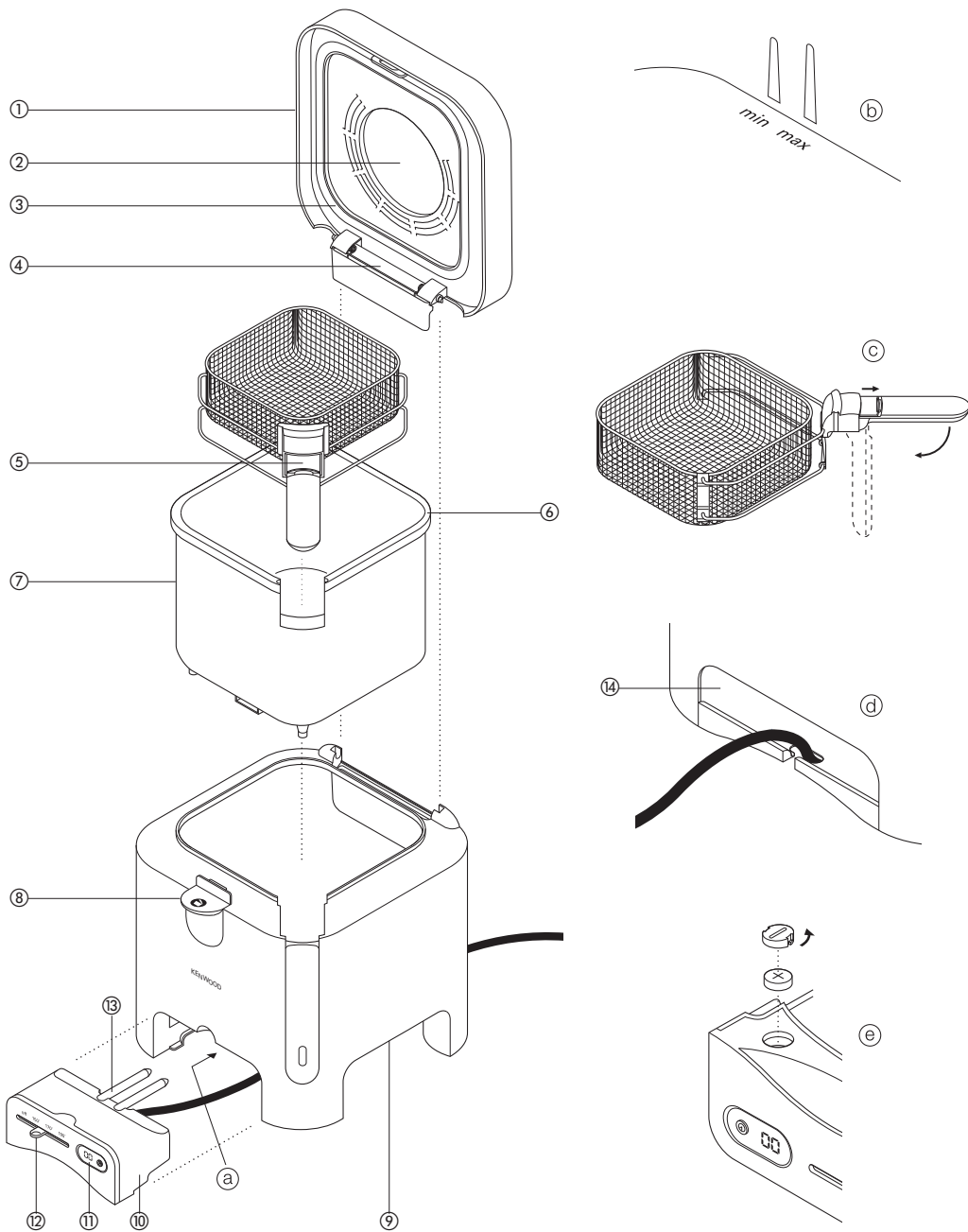

know your Kenwood deep fryer

safety

- Never plug in the fryer before filling the bowl with oil.
- Keep children away during use and after - fat stays hot for a long time.
- Never let the cord touch hot surfaces or hang down over the worktop edge - a child could grab it and pull the fryer down. Place excess cord in cord storage area at the back of the fryer.
- Never touch the bowl, pour away oil or move your fryer while the oil's hot.
- Never put the electrics unit in water. Remove it before washing the rest of your fryer.
- After cleaning, ensure the bowl and its electric pins are dry before use.
- Never leave your fryer on unattended.
- Take care when removing the electrics unit - the temperature probes may be hot.
- Do not use if there is any damage to the fryer, cord or plug. Get it checked or repaired: see 'service'.
- Only use the electrics unit supplied.
- Watch out for steam during cooking and when you open the lid.
- Never put your fryer near or on cooker hot plates.
- **Always unplug the fryer after use.**
- This appliance is not intended to be operated by means of an external timer or separate remote-control system.
- This appliance is not intended for use by persons (including children) with reduced physical, sensory or mental capabilities, or lack of experience and knowledge, unless they have been given supervision or instruction concerning use of the appliance by a person responsible for their safety.
- Children should be supervised to ensure that they do not play with the appliance.
- Only use the appliance for its intended domestic use. Kenwood will not accept any liability if the appliance is subject to improper use, or failure to comply with these instructions.

before plugging in

- Make sure your electricity supply is the same as the one shown on the underside of the electrics unit.

Important - UK only

- The wires in the cord are coloured as follows:
Green and Yellow = Earth,
Blue = Neutral,
Brown = Live.
- The appliance must be protected by a 13A approved (BS1362) fuse.
- **WARNING: THIS APPLIANCE MUST BE EARTHED.**

Note:

- For non-rewireable plugs the fuse cover MUST be refitted when replacing the fuse. If the fuse cover is lost then the plug must not be used until a replacement can be obtained. The correct fuse cover is identified by colour and a replacement may be obtained from your Kenwood Authorised Repairer (see Service).
- If a non-rewireable plug is cut off it must be DESTROYED IMMEDIATELY. An electric shock hazard may arise if an unwanted non-rewireable plug is inadvertently inserted into a 13A socket outlet.
- This appliance conforms to EC directive 2004/108/EC on Electromagnetic Compatibility and EC regulation no. 1935/2004 of 27/10/2004 on materials intended for contact with food.

before using for the first time

- 1 Remove all packaging.
- 2 Dismantle: see 'to dismantle, assemble and use your fryer'.
- 3 Wash the parts: see 'cleaning'.

know your Kenwood fryer

- ① removable lid with permanent mesh filter
- ② viewing window
- ③ lid seal
- ④ condensation trap
- ⑤ rise and fall control
- ⑥ pouring lips
- ⑦ removable bowl
- ⑧ lid release
- ⑨ carrying handles
- ⑩ electrics unit
- ⑪ timer
- ⑫ temperature control with neon light
- ⑬ temperature probes
- ⑭ cord storage

to dismantle, assemble and use your fryer

to dismantle

- 1 Push the lid release ⑧ down to open the lid. Then lift the lid off.
- 2 Lift up the handle and remove the basket.
- 3 Pull out the electrics unit and then remove the bowl.

- **Before removing the electrics unit check that the cord is released from the cord storage area at the back of the fryer ④.**

to assemble and use

- 1 Insert the bowl – 'MAX' and 'MIN' marks to the back of the fryer.
 - 2 Then insert the electrics unit ⑩ – cord to the back of the fryer ③ + ④.
 - 3 Pour in the oil. The level must be between the 'MAX' and 'MIN' marks ⑥.
 - 4 Insert the basket and close the lid. Then lower the handle by sliding back the rise & fall control ⑤.
 - 5 Plug in and select the required temperature ⑫.
 - 6 The light goes out when the oil reaches the right temperature to start frying. Fill the basket and lower into the oil ⑦. **Don't exceed the maximum food quantities stated.** The light will come on and off as the fryer maintains the temperature.
 - 7 Set the timer ⑪ by pressing the button until the required time is reached. The time will start counting down as soon as the button is released. See "operating the timer".
 - 8 When ready, raise the basket and allow the food to drain before opening the lid.
- To re-use oil, allow to cool then pour the oil through fine muslin or absorbent paper.

- **Always unplug the fryer after use.**

hints

- We would recommend the use of a good quality oil for deep frying, such as corn oil or groundnut oil. A good quality solid fat may also be used. Other oils may be used if they are specifically recommended by the manufacturer for deep frying. Never mix different oils or fat and do not use olive oil, butter or margarine as they will smoke or bubble over.
- Pre-cooked food needs a higher temperature than raw food.
- Cook food thoroughly. The outside may look ready before the inside is cooked.

- Keep your fryer with oil (cooled and strained) inside it, ready for use. The lid keeps the dust out.
- Before frying battered food, drain off excess batter.
- To make chips, cut potatoes up evenly, so they cook evenly. Rinse and dry before frying. For best results use dry floury textured potatoes i.e. King Edwards or Maris Piper.
- To prolong the life of your fryer, filter the oil after each use and change it after 8 - 10 uses.
- Shake off any excess ice before frying frozen foods.

maximum food capacities

- **fresh chips** 1.2Kg
- **frozen chips** 1Kg

oil capacity

- **maximum oil** 2.5 litres
- **minimum oil** 2 litres

Frying Times and temperature chart

The frying times given in this chart are a guide only and should be adjusted to suit the different quantities or thickness of food and to suit your own taste.

Food	Frying Temp	Frying time
Fresh Chips 800g/ ½ fill basket (recommended quantity for best results)	190°C	6 – 8 minutes
Fresh Chips 1.2Kg	190°C	9 – 12 minutes
Frozen Chips 1Kg	190°C	9 – 11 minutes
FISH		
Frozen scampi in breadcrumbs	170°C	3 – 5 minutes
White fish fillets portions in crumb or batter	170°C	10 – 15 minutes (depending on fish thickness)
Fresh Prawns in batter	190°C	3 – 5 minutes
CHICKEN		
Chicken portions in crumb	170°C	15 – 20 minutes (small/medium size) 20 – 30 minutes (large size)
Fresh chicken drumsticks in crumb	170°C	15 minutes
Frozen Chicken nuggets	190°C	6 – 8 minutes
FRUIT/VEGETABLES		
Fruit fritters 2 – 3pieces	190°C	3 – 5 minutes
Vegetable fritters	190°C	3 – 5 minutes
Frozen Onion Rings	190°C	3 – 5 minutes
Fresh Onions/mushrooms	150°C	3 – 5 minutes

operating the timer

- 1 Press the button once, the display will flash "00".
- 2 Press again to set the countdown time in 1 minute intervals. Hold the button in until the required set time is reached ie "05" = 5 minutes. Then release the button.
Note: The timer will only display seconds when the countdown time is below 1 minute.
- 3 The display will flash for 5 seconds - during this period the set time can be increased by holding the button in again. After 5 seconds the display will stop flashing and the countdown will begin.
- 4 To change the countdown time during operation, press and hold the button in for 3 seconds. The display will reset to "00" and a new time can be set.
- 5 When the countdown has finished the timer will "beep" for 15 seconds. To stop the timer beeping, press the button once.
- 6 The display will automatically turn off after 45 seconds if not in use.

care and cleaning

- **Never start cleaning until the oil has cooled down.**
- Always unplug and remove the electrics unit before cleaning.
- Ensure everything's completely dry before reassembling.
- **electrics unit**
- **Never put it in water.**
- Before removing the electrics unit check that the cord is released from the cord storage area at the back of the fryer ☹.
- Pull out. Wipe with a damp cloth and dry thoroughly.
- **lid**
- Remove and soak in hot soapy water for 20 minutes.
- **basket**
- After each use, remove and soak in hot soapy water for 20 minutes. Then use a stiff brush.

fryer body and bowl

- Soak in hot soapy water for 20 minutes. Then use a non-abrasive cleaner.
- If you have a dishwasher everything - except the electrics unit - is dishwasher safe. Your dishwasher may darken the inside of the lid but it will still work perfectly. For baked on oil, we recommend soaking the bowl prior to dishwashing.

replacing the timer battery

- 1 Turn the battery cover anti-clockwise and remove the battery (Ⓜ).
- 2 Replace the battery - type L1154 or equivalent from your local electrical retailer or chemist.
- 3 Fit the new battery ensuring it is the correct way round and replace the cover.

service and customer care

- If the cord is damaged it must, for safety reasons, be replaced by Kenwood or an authorised Kenwood repairer.
- **If you experience any problems with the operation of the fryer, before calling for assistance refer to the troubleshooting guide.**

UK

If you need help with:

- using your fryer or
 - servicing or repairs (in or out of guarantee)
- ☎ call Kenwood on **023 92392333** and ask for Customer Care. **Have your model number ready** - it's on the underside of the fryer.

spares and attachments

- ☎ call 0870 2413653

other countries

- Contact the shop where you bought your fryer.
- Designed and engineered by Kenwood in the UK.
- Made in China.

guarantee (UK only)

If your fryer goes wrong within one year from the date you bought it, we will repair or where necessary replace it free of charge provided:

- you have not misused, neglected or damaged it;
- it has not been modified (unless by Kenwood);
- it is not second-hand;
- it has not been used commercially;
- you have not fitted a plug incorrectly; and
- **you supply your receipt to show when you bought it.**

This guarantee does not affect your statutory rights.



IMPORTANT INFORMATION FOR CORRECT DISPOSAL OF THE PRODUCT IN ACCORDANCE WITH EC DIRECTIVE 2002/96/EC.

At the end of its working life, the product must not be disposed of as urban waste. It must be taken to a special local authority differentiated waste collection centre or to a dealer providing this service. Disposing of a household appliance separately avoids possible negative consequences for the environment and health deriving from inappropriate disposal and enables the constituent materials to be recovered to obtain significant savings in energy and resources. As a reminder of the need to dispose of household appliances separately, the product is marked with a crossed-out wheeled dustbin.

Troubleshooting guide

Problem	Possible Cause	Solution
Fryer does not work	Fryer not plugged in	Check fryer is plugged in
	Fuse blown	Check the fuse/circuit breaker for your installation and replace the fuse if necessary. If this does not solve the problem refer to the "service" section.
	Electrics unit not fitted	Check that electrics unit is inserted properly.
Oil overflowing	Maximum oil level exceeded	Check oil level.
	Basket overloaded/maximum chip capacity exceeded	Refer to frying chart for recommended quantities.
	Wet food placed in oil	Drain and dry food thoroughly.
	The oil is old and has deteriorated	Replace with fresh oil.
	Incorrect oil used/different oils mixed together	Use a good quality oil suitable for deep frying.
Unpleasant Odour/Oil smokes	The oil is old and has deteriorated	Replace with fresh oil.
	The oil is not suitable for deep frying	Use a good quality oil suitable for deep frying.
Poor Frying performance	Incorrect temperature used	Select the correct temperature.
	Basket overloaded	Reduce the quantity fried.
	Fresh chips too wet	Drain and dry the chips thoroughly.
	Frying method	Try batch method for fresh chips 170°C for 9–11 minutes Then increase temperature to 190°C and cook for a further 1–2 minutes.
Timer not working	Battery needs replacing	Change battery - see "care and cleaning."



Head Office Address: Kenwood Limited, New Lane, Havant, Hampshire PO9 2NH, UK
www.kenwoodworld.com

Designed and engineered by Kenwood in the UK
Made in China

56300/2

Free Manuals Download Website

<http://myh66.com>

<http://usermanuals.us>

<http://www.somanuals.com>

<http://www.4manuals.cc>

<http://www.manual-lib.com>

<http://www.404manual.com>

<http://www.luxmanual.com>

<http://aubethermostatmanual.com>

Golf course search by state

<http://golfingnear.com>

Email search by domain

<http://emailbydomain.com>

Auto manuals search

<http://auto.somanuals.com>

TV manuals search

<http://tv.somanuals.com>