

KETTLER

HKS-SELECTION

Montage- und Trainingsanleitung „APOLLO“

Art.-Nr. 07426-700



A 150 cm
B 85 cm
C 226 cm



max.
110 kg



~ 45 Min.



Auf 100% Altpapier!

Abb. ähnlich



MADE IN GERMANY

2-3 (D)

4-5 (GB)

6-7 (F)

8-9 (NL)

10-11 (E)

12-13 (I)

14-15 (PL)

16-17 (CZ)

18-19 (P)

20-21 (DK)

22-23 (RO)

24-25 (H)

26-27 (RUS)

28-29 (S)

30-31 (TR)



Please read these instructions carefully prior to carrying out assembly and using for the first time. They contain information which is important for your safety as well as for the use and maintenance of the appliance. Keep these instructions in a safe place for reference purposes, maintenance work and to assist you when ordering spare parts.

For Your Safety

- ⚠ **RISK!** While assembly of the product keep off children's reach (Choking hazard - contains small parts).
- ⚠ **RISK!** Any other use of the equipment is prohibited and may be dangerous. The manufacturer cannot be held liable for damage or injury caused by improper use of the equipment.
- ⚠ **RISK!** Instruct persons using the equipment (in particular children) on possible sources of danger during exercising. Only for appliances with weights or dumbbells. This especially applies to the area of movement of weights and dumbbells.
- ⚠ **RISK!** Incorrect repairs and structural modifications (e.g. removal or replacement of original parts) may endanger the safety of the user.
- ⚠ **WARNING!** The training device should be used only for its intended purpose, i.e. for physical exercise by adult people.
- ⚠ **WARNING!** Before beginning your program of training, study the instructions for training carefully.
- ⚠ **WARNING!** Any interference with parts of the product that are not described within the manual may cause damage, or endanger the person using this machine. Extensive repairs must only be carried out by KETTLER service staff or qualified personnel trained by KETTLER.
- The training device has been designed in accordance with the latest standards of safety. Any features which may have been a possible cause of injury have been avoided or made as safe as possible.
- The training device corresponds with DIN EN 957 -1/-2, class HB. It is therefore unsuitable for therapeutic use.
- In case of enquiry, please contact your KETTLER dealer.
- If the equipment is in regular use, check all its components thoroughly every 1–2 months. Pay particular attention to the tightness of bolts and nuts.
- Before beginning your program of exercise, consult your doctor to ensure that you are fit enough to use the equipment. Base your program of exercise on the advice given by your doctor. Incorrect or excessive exercise may damage your health!
- Before use, always check all screws and plug-in connections as well as respective safety devices fit correctly.
- Always wear suitable shoes when using.
- Our products are subject to a constant innovative quality assurance. We reserve the right to perform technical modifications.
- In choosing the location of the apparatus, ensure a sufficient safety distance from any obstacles. The apparatus must not be mounted in the immediate vicinity of main passageways (paths, doorways, corridors).
- Always observe the general safety rules and precautions for working with electrical equipment.
- Nobody may be in the moving range of a training person during training
- This exercise machine may only be used for exercises indicated in the training instructions.
- The surface on which the unit is placed must be firm and even. Place rubber or straw mats under it to deaden any noise or impacts. Only for appliances with weights. Avoid powerful oscillations of the dumbbells!
- When mounting the product please take the recommended torque information into account ($M = xx \text{ Nm}$).

Instructions for Assembly

- ⚠ **RISK!** Ensure that your working area is free of possible sources of danger, for example don't leave any tools lying around. Always dispose packaging material in such a way that it may not cause any danger. There is always a risk of suffocation if children play with plastic bags!
- ⚠ **WARNING!** Please note that there is always a danger of injury when working with tools or doing manual work. Therefore please be careful when assembling this machine.
- Ensure that you have received all the parts required (see check list) and that they are undamaged. Should you have any cause for complaint, please contact your KETTLER dealer.
- Before assembling the equipment, study the drawings carefully and carry out the operations in the order shown by the diagrams. The correct sequence is given in capital letters.
- The equipment must be assembled with due care by an adult person. If in doubt call upon the help of a second person, if possible technically talented.
- The fastening material required for each assembly step is shown in the diagram inset. Use the fastening material exactly as instructed.
- Bolt all the parts together loosely at first, and check that they have been assembled correctly. Tighten the locknuts by hand until resistance is felt, then use spanner to finally tighten nuts completely against resistance (locking device). Then check that all screw connections have been tightened firmly. Attention: once locknuts have been unscrewed they no longer function correctly (the locking device is destroyed), and must be replaced.
- For technical reasons, we reserve the right to carry out preliminary assembly work (e.g. addition of tubing plugs).
- For machines with rope systems: please ensure that all ropes are fixed correctly. This is especially important for latissimus bars.

Handling the equipment

- Before using the equipment for exercise, check carefully to ensure that it has been correctly assembled.
- It is not recommended to use or store the apparatus in a damp room as this may cause it to rust. Please ensure that no part of the machine comes in contact with liquids (drinks, perspiration etc.). This may cause corrosion.
- The machine is designed for use by adults and children should not be allowed to play with it. Children at play behave unpredictably and dangerous situations may occur for which the manufacturer cannot be held liable. If, in spite of this, children are allowed to use the equipment, ensure that they are instructed in its proper use and supervised accordingly.
- Before beginning your first training session, familiarize yourself thoroughly with all the functions and settings of the unit.
- When choosing a place for the equipment please ensure that the floor can withstand the additional weight/load.

Care and Maintenance

- Basically this equipment does not need any special maintenance.
- Damaged components may endanger your safety or reduce the lifetime of the equipment. For this reason, worn or damaged parts should be replaced immediately and the equipment taken out of use until this has been done. Use only original KETTLER spare parts.
- To ensure that the safety level is kept to the highest possible standard, determined by its construction, this product should be serviced regularly (once a year) by specialist retailers.
- Use for your regular cleaning, maintenance and care our appliance maintenance set (Article no. 07921-000) specifically licensed for KETTLER Sports apparatus and available from the Sport specialized trade.
- Please ensure that liquids or perspiration never enter the machine or the electronics.

List of spare parts page 56-59

When ordering spare parts, always state the full article number, spare-partnumber, the quantity required and the S/N of the product (see handling).

Example order: Art. no. 07426-700 / spare-part no. 91380119 / 2 pieces / S/N Please keep original packaging of this article, so that it may be used for transport at a later date, if necessary.

Goods may **only** be returned after prior arrangement and in (internal) packaging, which is safe for transportation, in the original box if possible. It is important to provide a detailed defect description / damage report!

Important: spare part prices do not include fastening material; if fastening material (bolts, nuts, washers etc.) is required, this should be clearly stated on the order by adding the words „**with fastening material**“.

Waste Disposal

KETTLER products are recyclable. At the end of its useful life please dispose of this article correctly and safely (local refuse sites).

GB KETTLER GB Ltd.

Kettler House, Merse Road
North Moons Moat
Redditch, Worcestershire B98 9HL

www.kettler.co.uk

☎ +44 1527 591901

📠 +44 1527 62423

e-mail: sales@kettler.co.uk

USA KETTLER International Inc.

1355 London Bridge Road
Virginia Beach, VA 23453

www.kettlerusa.com

☎ +1 888 253 8853

📠 +1 888 222 9333

e-mail: sales@kettler.co.uk

Messhilfe für Verschraubungsmaterial

- GB - Measuring help for screw connections
- F - Gabarit pour système de serrae
- NL - Meethulp voor schroefmateriaal
- E - Ayuda para la medición del material de atornilladura
- I - Misura per materiale di avvimento
- PL - Wzornik do połączeń śrubowych
- CZ - Měřicí pomůcka pro materiál k přišroubování
- P - Auxiliar de medição para materiais de aparafusamento
- DK - Hjælp til måling af skruer
- RO - Ajutor pentru măsurarea materialului de înșurubat
- H - Mérő segédeszköz csavaranyaghoz
- RUS - Справка по определению размеров крепежных материалов
- S - Måthjälp för skruvmaterial
- TR - Vidalama malzemesi için ölçüm desteği

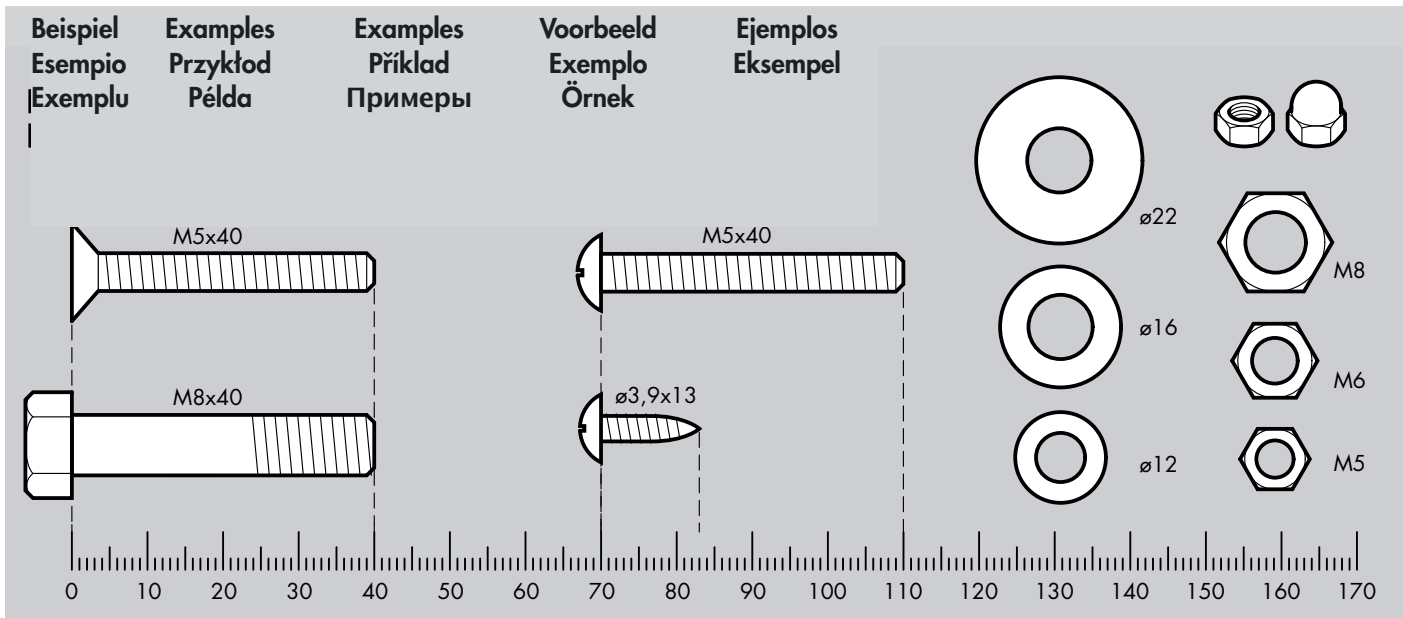



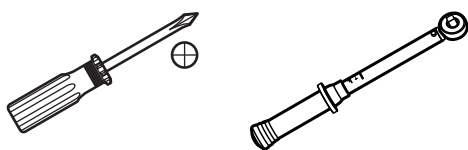





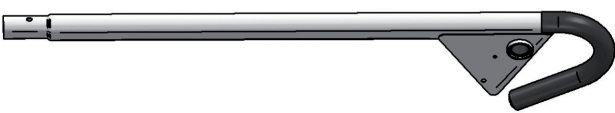
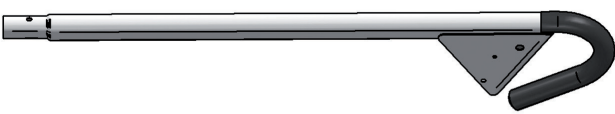
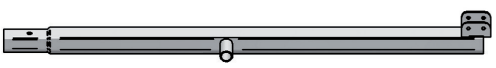
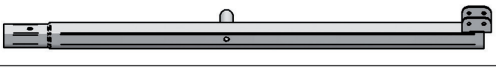

- D - Benötigtes Werkzeug - Gehört nicht zum Lieferumfang.
- GB - Tools required - Not included.
- F - Outils nécessaires - Ne fait pas partie du domaine de livraison.
- NL - Benodigd gereedschap - Is niet bij de levering inbegrepen.
- E - Herramientas necesarias - No forma parte del volumen de entrega.
- I - Strumenti necessari - Non in dotazione alla fornitura.
- PL - Narzędzi - Nie należy do zakresu dostawy.
- CZ - Nářadí potřebné - Nepatří do rozsahu dodávky
- P - Ferramentas necessárias - Não está incluído nas peças fornecidas
- DK - Værktøjer kræves - Er ikke inkluderet i leveringsomfanget.
- RO - Unelte necesare - nu este inclus.
- H - Szükséges szerszámok - Nem is.
- RUS - Необходимый инструмент - не включены.
- S - Verktyg som du behöver - ingår inte i köpet.
- TR - İhtiyaç duyulan aletler - paket kapsamında bulunmamaktadır.

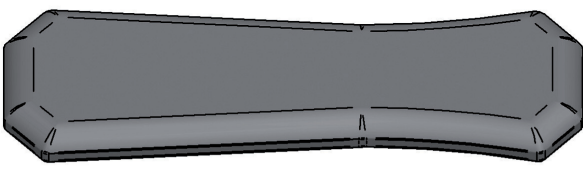
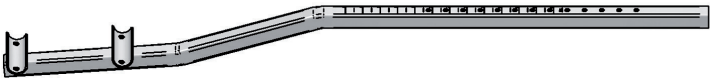

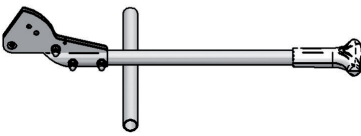

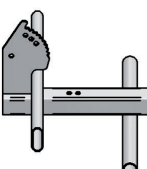







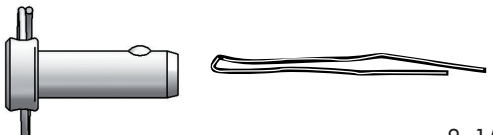







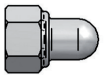
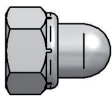
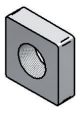





Checkliste (Packungsinhalt)

- GB - Checklist (contents of packaging)
- F - Liste de vérification (contenu de l'emballage)
- NL - Checklijst (verpakkinginhoud)
- E - Lista de control (contenido del paquete)
- I - Lista di controllo (contenuto del pacco)
- PL - Lista kontrolna (zawartość opakowania)
- CZ - Kontrolní seznam (obsah balení)
- P - Lista de verificação (conteúdo da embalagem)
- DK - Checkliste (pakkens indhold)
- RO - Lista de verificare (conținutul pachetului)
- H - (Csomagolás tartalmának) ellenőrző listája
- RUS - Контрольный список
- S - Checklista
- TR - Kontrol listesi (Ambalaj içeriği)

		1
		1
		1
		1
		1
		1
		1
		1
		1
		1
		2/2
		1/4
		1/1

Checkliste (Packungsinhalt)

	ø8x41	1
	ø8x32	2
	ø8x15	1
	M6x50	2
	M8x25	1
	M8x30	4
	M8x85	2
	M6x45	4
	M8x45	8
	M5x45	4
	AM5x10	2
	M6	6
	M8	11
	M8	2

	ø12,5x6,4	6
	ø15,5x5,3	2
	ø16x8,3	13
	ø21x10,5	2
	ø25x8,4	2
	ø13x12	2
	SW10	2
	SW13	2
		2
	ø25	4
	20x20	4
	50x20	2
		4

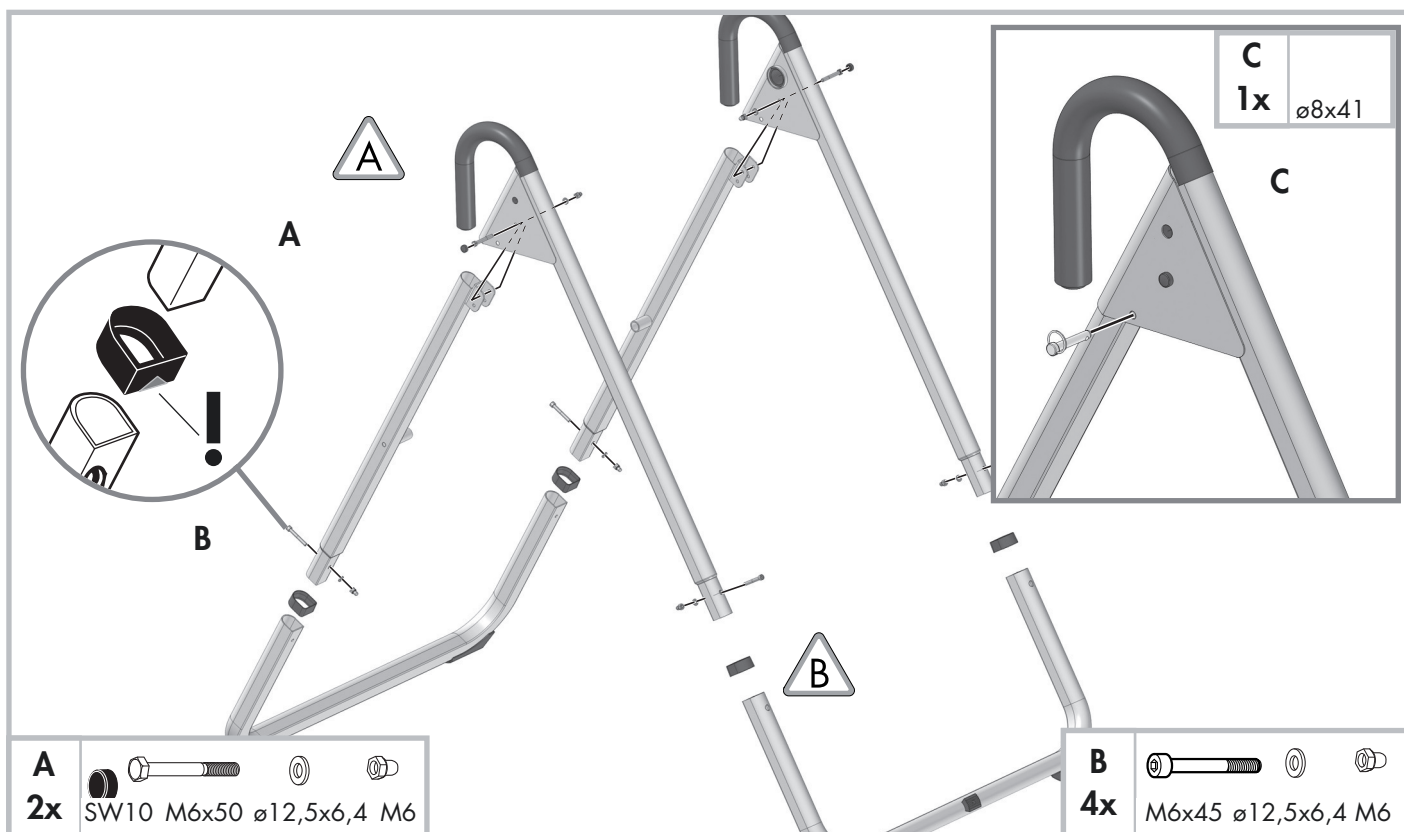

- D - Die Schraubverbindung noch nicht fest anziehen.
- GB - Do not tighten the bolts yet.
- F - Ne pas encore serrer la visserie à fond.
- NL - Draai de schroefverbinding nog niet vast aan.
- E - No apriete aún fuertemente los tornillos.
- I - Non serrare ancora i collegamenti a vite
- PL - Nie dokręcać jeszcze połączeń śrubowych.
- CZ - Šroubové spojení zatím nedotahujte napevno.
- P - Ainda não aperte a união roscada
- DK - Spænd ikke boltene endnu.
- RO - Încă nu strângeți îmbinarea cu șuruburi.
- H - A csavarokat még ne húzza meg szorosra
- RUS - Начните со слабой затяжки винтов.
- S - Vänta med att dra åt skruven ordentligt.
- TR - Vida bağlantısı henüz daha sıkıştırılmamalıdır.



- D - Achten Sie beim Einsetzen der Fußbügel auf die dargestellte richtige Lage der Fuß- bzw. Anschlagstopfen.
- GB - When inserting the foot bar, ensure that the foot and buffer stops are in the correct position as shown.
- F - A la mise en place des cintres pour les pieds, veiller au positionnement correct, comme représenté, par les bouchons de butée.
- NL - Let bij het aanbrengen van de voetbeugel op de afgebeelde - correcte - positie van de voet- resp. aanslagdop.
- E - Al aplicar los estribos de pie observe la posición correcta de los tapones de las patas o de tope.
- I - Quando si inserisce la staffa del piede fare attenzione che la posizione dei tappi del piede e/o d'arresto sia corretta, come quella raffigurata.
- PL - Przy zakładaniu drążków pod stopy zwracać uwagę na przedstawione tu prawidłowe położenie zatyczek nożnych i ogranicznikowych.
- CZ - Při nasazování klipsen dbejte na vyobrazenou správnou pozici nožních dorazů a dorazových nárazníků.
- P - Na colocação dos aros para os pés deve observar a posição correcta representada dos tampões para os pés ou de batente.
- DK - Sørg for at fod- og stopproppe sidder i den rigtige viste position ved isætning af fodstøtten.
- RO - La montarea suportului pentru picior aveți în vedere poziția corectă a dopurilor opritoare.
- H - A lábhajlat behelyezésekor ügyeljen a láb- ill. Ütköző dugók képen látható megfelelő elhelyezkedésére.
- RUS - При установке переключины для ног обратите внимание на представленное правильное положение или
- S - Se till att fot- resp. stoppskyddet hamnar i samma läge som på bilden när fotbygel monterar.
- TR - Ayak geçme yerlerini takarken ayak veya dayanma yerlerinin doğru konumlanmasına özen gösteriniz.

2

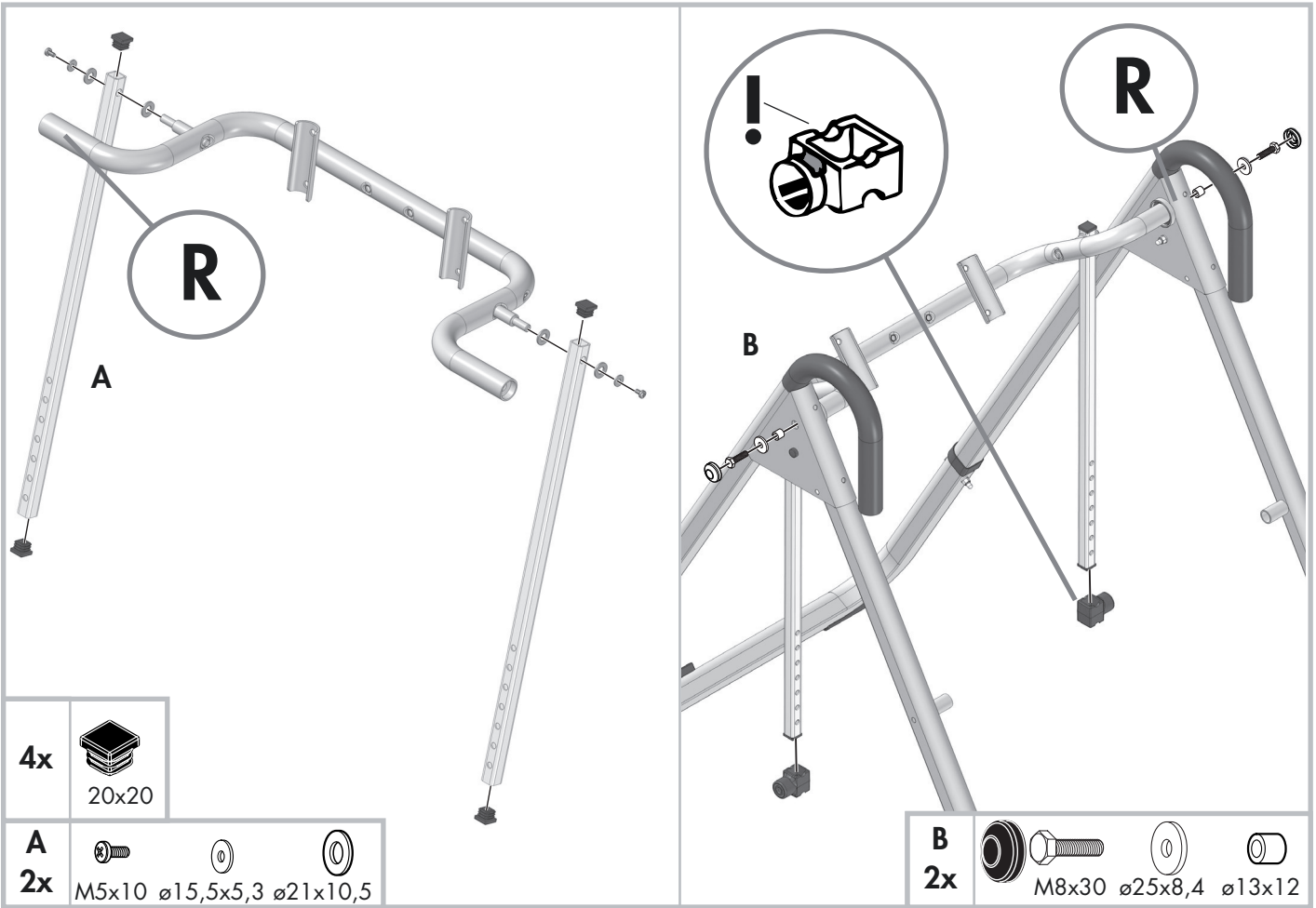
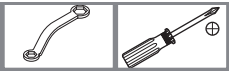

4x
20x20

A
2x
M5x10 $\varnothing 15,5 \times 5,3$ $\varnothing 21 \times 10,5$

B
2x
M8x30 $\varnothing 25 \times 8,4$ $\varnothing 13 \times 12$

3

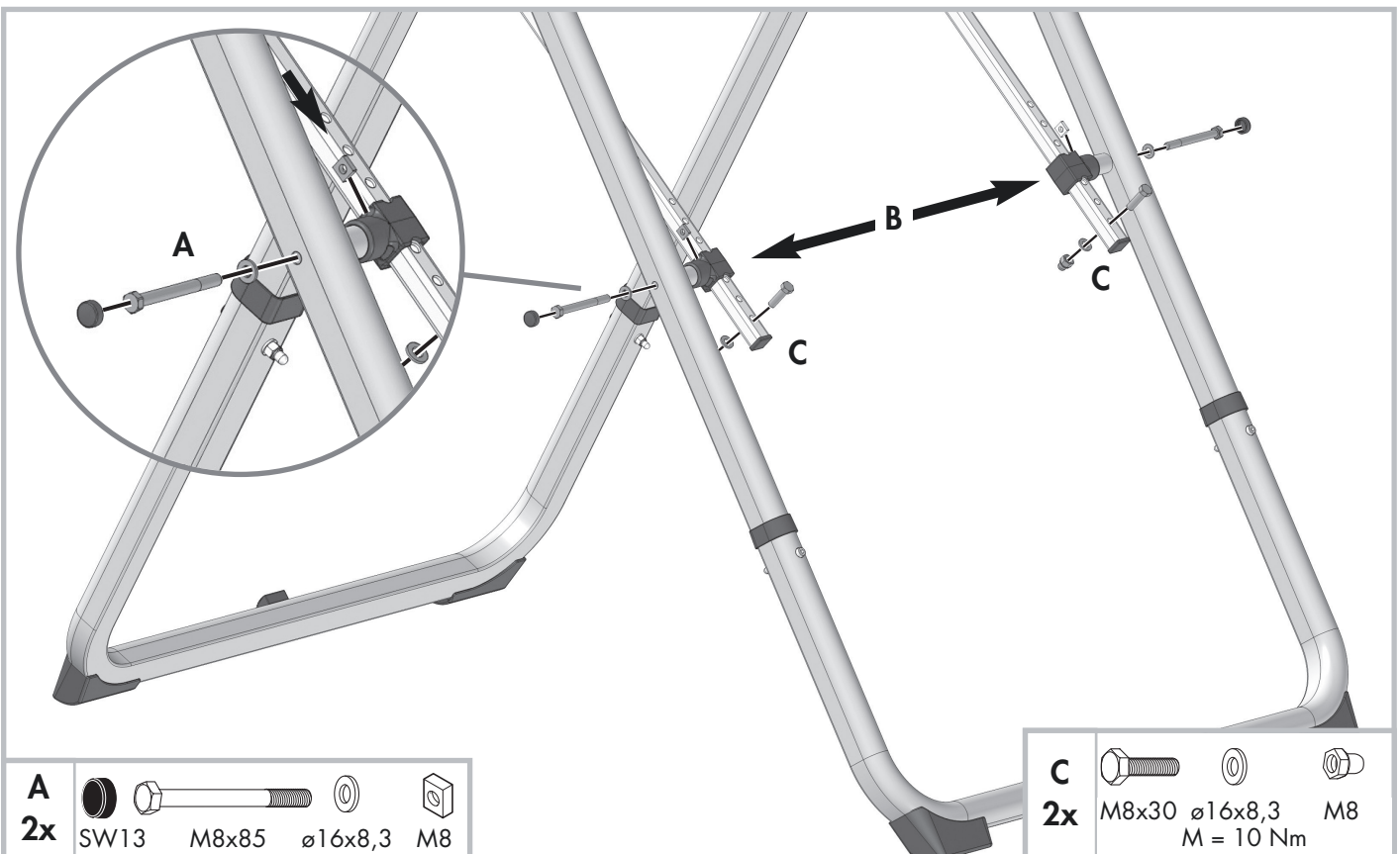

A
2x
SW13 M8x85 $\varnothing 16 \times 8,3$ M8

C
2x
M8x30 $\varnothing 16 \times 8,3$ M8
M = 10 Nm

4

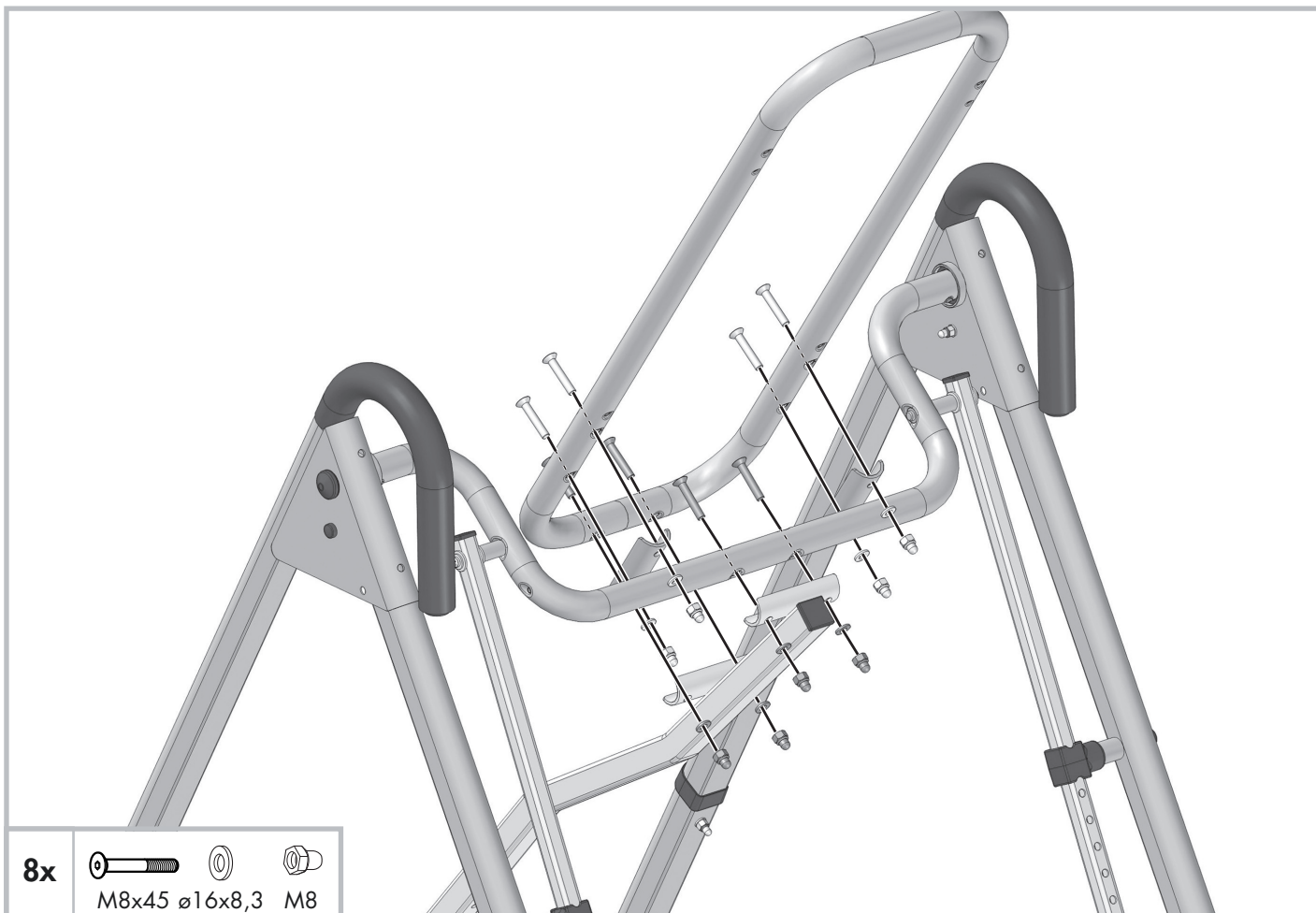

8x



M8x45 ø16x8,3 M8

5

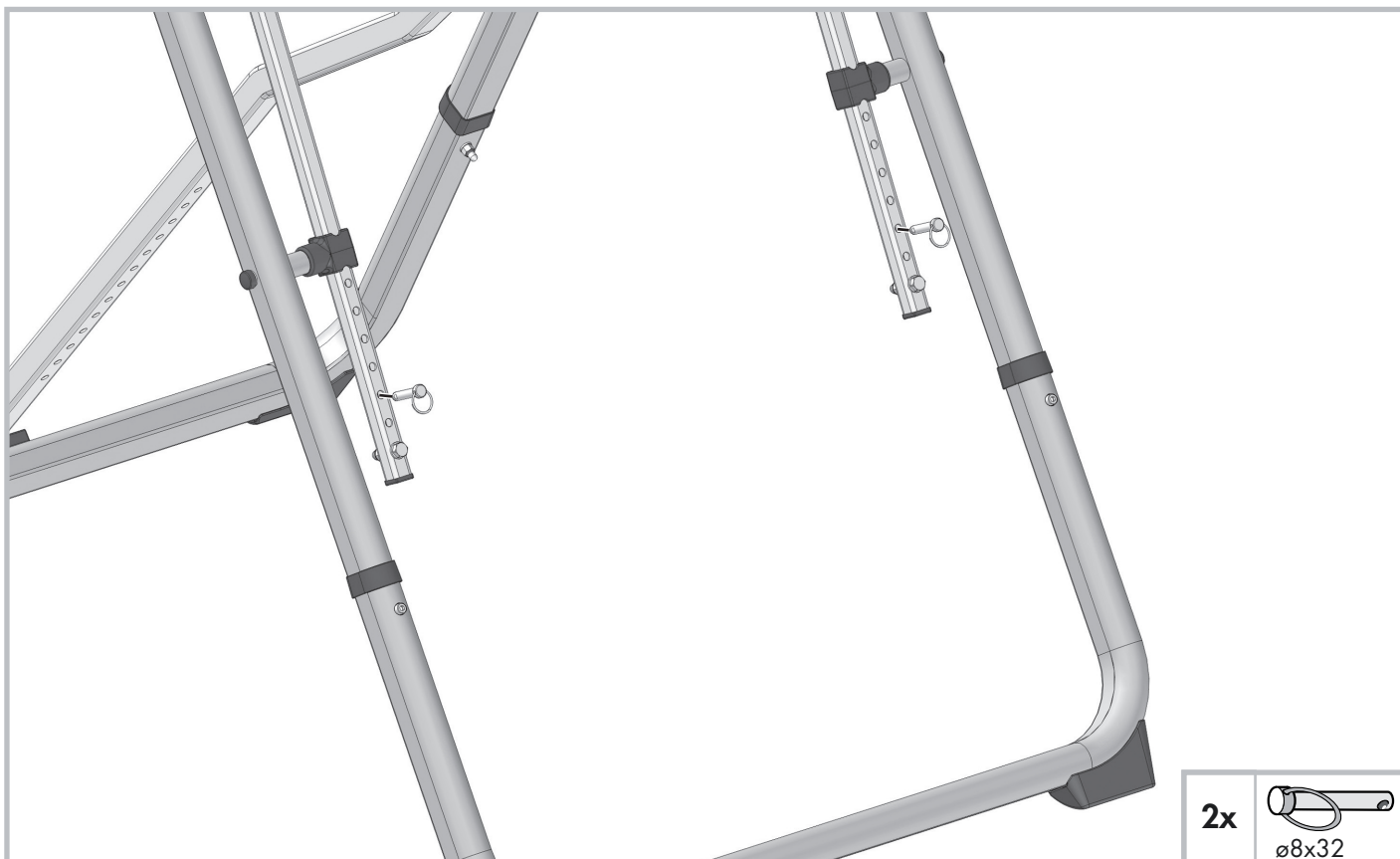

2x



ø8x32

6

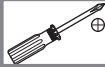

4x M5x45

7

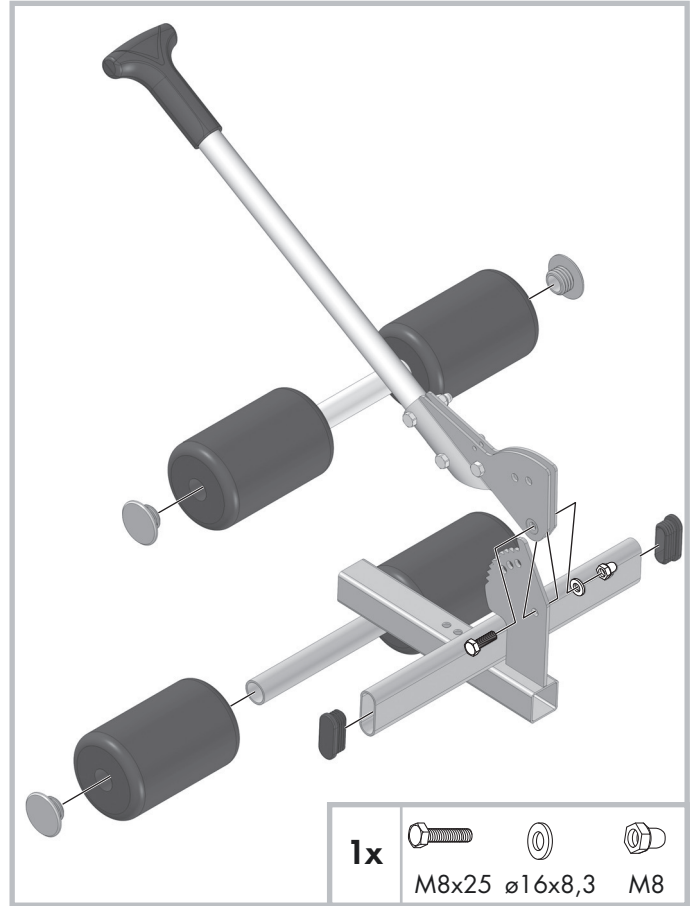

1x
M8x25 ø16x8,3 M8



- D - Beim Eindrehen der Schrauben keinen Druck ausüben, da die Gefahr besteht, dass sich die innenliegenden Muttern lockern.
- GB - When screwing the bolts in, do not use force as this may dislodge the nuts on the inside.
- F - Ne pas exercer de pression quand on visse, car on risque de desserrer les écrous intérieurs.
- NL - Oefen bij het aanbrengen van de schroeven geen druk uit, daar er gevaar bestaat, dat de binnenste moeren losraken.
- E - No ejerza presión al atornillar los tornillos ya que existe el peligro de que se suelten las tuercas que se encuentran en el interior.
- I - Quando si avvitano le viti non fare pressione, altrimenti c'è pericolo che i dadi all'interno si allentino.
- PL - Wkręcać śruby nie wywierając nacisku, ponieważ zachodzi wówczas obawa, że poluzują się położone wewnątrz nakrętki.
- CZ - Při dotahování šroubů nevyvíjejte žádný tlak, protože vzniká nebezpečí, že by se uvolnily matky, které se nacházejí uvnitř.
- P - Ao enrosar os parafusos não deve exercer qualquer pressão, uma vez que existe o perigo de desapertar as porcas no interior.
- DK - Brug ikke unødigt kraft, når boltene skrues på, da det kan løsne møtrikkerne på indersiden.
- RO - Nu exercitați presiune la înfiletarea șuruburilor, deoarece există pericolul slăbirii piulițelor din interior.
- H - A csavarok betekerésekor ne fejtse ki nyomást, mivel fennáll annak a veszélye, hogy a belül fekvő csavarok meglazulnak.
- RUS - Во время завинчивания не применяйте силу, так как крепление расположенных внутри гаек может ослабиться.
- S - Undvik tryck när du skruvar i skruvarna, annars finns det risk för att muttrarna inuti lossar.
- TR - Vidaları takarken baskı yapılmamalıdır, çünkü aksi takdirde iç taraftaki somunların gevşemesi ihtimali bulunmaktadır.

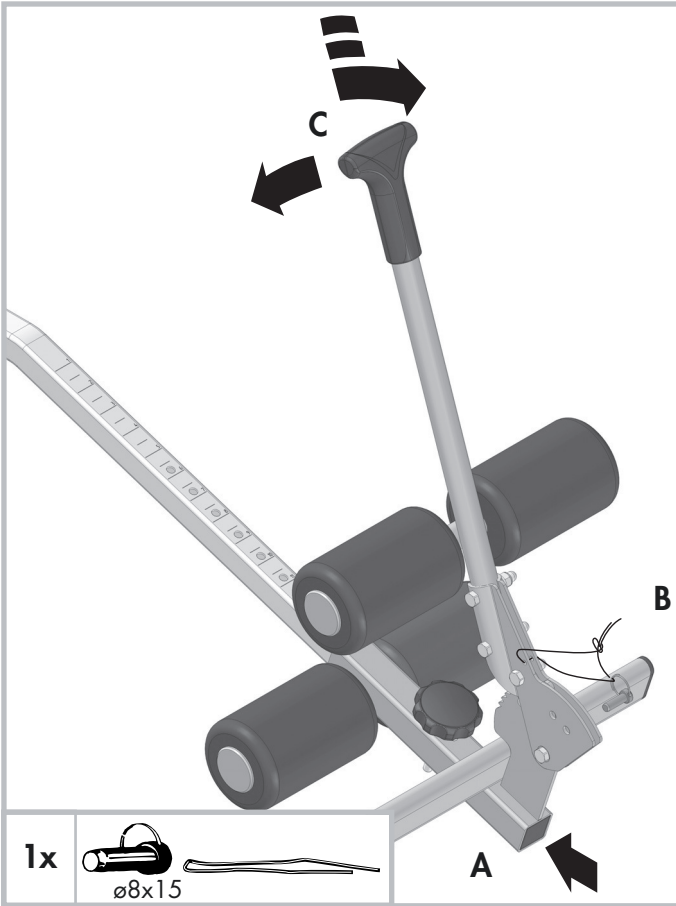

D Trainingsanleitung

Rückenschmerzen durch Verspannungen, Fehlbelastungen und Überlastungsschäden der Wirbelsäule gehören zu den weitverbreitetsten Zivilisations- und den am häufigsten angezeigten Berufskrankheiten unserer Zeit.

Daher ist es dringend erforderlich, frühzeitig diesen Beschwerden entgegenzuwirken, bevor sich z. B. Bandscheibenschäden einstellen. Entspannungs- und Entlastungsübungen für die Wirbelsäule und den gesamten Bewegungsapparat beugen dieser Volkskrankheit vor.

Mit dem KETTLER APOLLO erreichen Sie eine Entlastung der Wirbelsäule. Hierbei wird der Druck von den Bandscheiben genommen, die die unter Belastung abgegebene Flüssigkeit sowie Nährstoffe wieder aufnehmen können. Des Weiteren werden durch die Streckung Muskelverspannungen gelöst.

Die „Über-Kopf-Lage“ sorgt darüber hinaus für eine bessere Durchblutung und Sauerstoff-Versorgung der Muskulatur sowie wichtiger Organe der oberen Körperhälfte, insbesondere des Gehirns.

Orthopäden und Sportärzte empfehlen die „Über-Kopf-Lage“ zur Entlastung der Bandscheiben, der Hüft- und Kniegelenke sowie zur Vorbeugung gegen Rückenschmerzen und Muskelverspannungen. Belastungsbedingte Rücken- und Gelenkschmerzen lassen spürbar nach beim Einsatz des APOLLO.

Wichtige Hinweise

Auch wenn das Gerät für die Selbstbedienung konstruiert ist, sollte eine zweite Person sicherheitshalber Hilfestellung leisten.

Lassen Sie vor Übungsaufnahme durch Ihren Hausarzt abklären, ob Sie für Übungen mit dem APOLLO gesundheitlich geeignet sind. Der ärztliche Befund sollte Grundlage für den Aufbau Ihres Trainingsprogramms sein. Falsches oder übermäßiges Training kann zu Gesundheitsschäden führen.

Bei extremem Bluthochdruck, Augenhochdruck, akuten organischen oder psychischen Störungen und während der Schwangerschaft ist das Gerät nicht zu benutzen.

Trainingshinweise

Beginnen Sie Ihr regelmäßiges Training in „Über-Kopf-Lage“ mit einer Übungszeit von ca. 1 Minute und steigern Sie diese individuell um ca. 1/2 Minute täglich. Begeben Sie sich nicht sofort in die maximale Übungsposition sondern „tasten“ Sie sich allmählich - wie im folgenden Abschnitt beschrieben - an die vollständige „Über-Kopf-Lage“ heran. Insbesondere nach vorangegangenen intensiven Belastungen der Wirbelsäule (längere Autofahrten, sitzende Tätigkeit usw.) empfiehlt sich das Entspannungstraining mit dem APOLLO.

GB Exercising instructions

Backaches, stiffness, the effects of poor posture and overstrain are among the most widespread complaints in our modern industrial civilization.

It is therefore essential to take early action to prevent such complaints from occurring, i.e. before the intervertebral disks are damaged beyond repair. Special exercises to relax spine and muscles are an effective way of doing this.

The KETTLER APOLLO reduces stress on the back and relieves pressure on the intervertebral disks by allowing them to reabsorb the fluids discharged when they are in action. The stretching process also helps to relieve tension in the muscles.

The "head downwards" position also ensures better circulation and a more ample supply of oxygen to the muscles and important organs in the upper part of the body, in particular the brain.

Orthopedists and physiotherapists recommend the "head downwards" position for relieving stress on the vertebral disks, the hips and knee joints, as well as for preventing muscular tension. Regular use of the APOLLO provides real relief from backaches and painful joints.

Important note

Even if the unit is designed for use by one person, assistance from a second person may be useful. Before you use the APOLLO, have a check-up by your doctor to ensure you are fit enough to do the exercises. Keep his advice in mind when working out your training program. Remember that the wrong type of exercise or excessive exercise may damage your health.

The device is not to be used if you have extremely high blood pressure, glaucoma, acute organic or mental disturbances and when pregnant.

Note on exercising

Begin your regular training in the "head downwards" position for only one minute per day, and increase this by about half a minute daily over a period of time. Do not swing into the maximum position immediately, but work your way into it slowly as described below. Relaxation and exercise with the APOLLO is especially recommended after long periods of strain on the back, e.g. after driving long distances or in sedentary occupations etc.

F Instructions pour l'entraînement

Les douleurs dans le dos occasionnées par tensions, charges exagérées et les lésions dues aux surcharges de la colonne vertébrale comptent parmi les maladies les plus répandues de notre civilisation et les maladies professionnelles les plus fréquentes de nos jours. Il est donc urgent de réagir de bonne heure à ces symptômes avant que ne se produisent par exemple des dommages tels que la discopathie. Pour prévenir cette maladie populaire, les exercices de relaxation et de détente sont indispensables pour la colonne vertébrale et l'appareil moteur tout entier.

Avec l'appareil Apollo on déleste la colonne vertébrale. Les exercices permettent d'éviter la pression des disques intervertébraux qui peuvent alors réabsorber le liquide et les substances nutritives perdus en charge. De plus, les mouvements d'extension servent à éliminer les tensions musculaires.

La "position tête en bas" améliore l'irrigation sanguine et l'approvisionnement en oxygène de la musculature ainsi que d'importants organes de la partie supérieure du corps, en particulier du cerveau.

Les orthopèdes et la médecine sportive recommandent la "position tête en bas" pour délester les disques intervertébraux, les articulations des hanches et des genoux, ainsi que pour prévenir les douleurs dorsales et les tensions des muscles. Après l'utilisation de l'appareil APOLLO, les douleurs du dos et des muscles, dues aux sollicitations, diminuent sensiblement.

Consignes importantes

Bien que l'appareil ait été construit pour s'en servir soi-même, une deuxième personne devrait être prévue, par mesure de sécurité, pour venir éventuellement en aide.

D Einstellen und Auspendeln des APOLLO

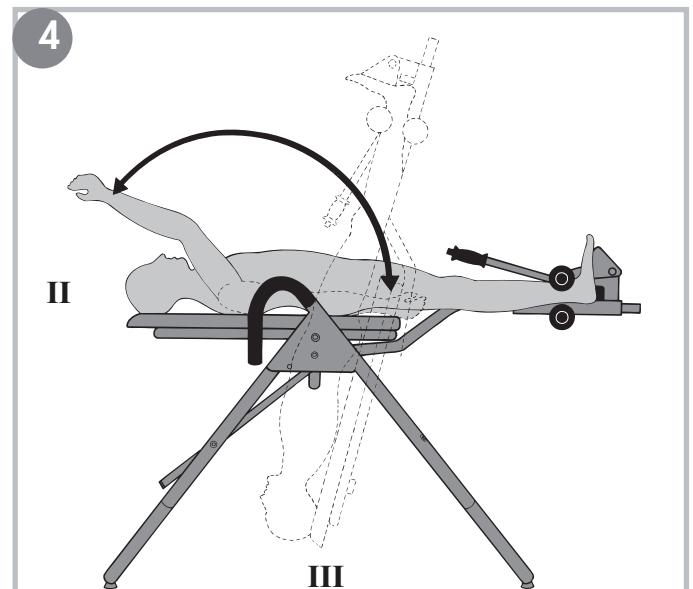
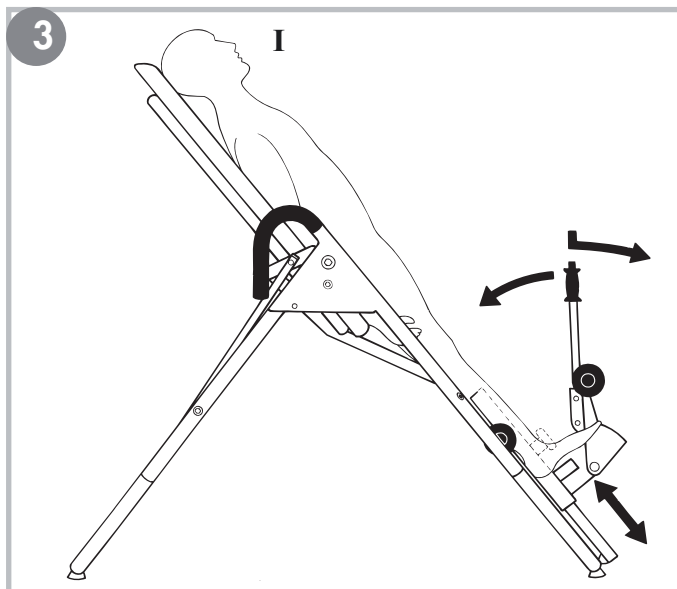
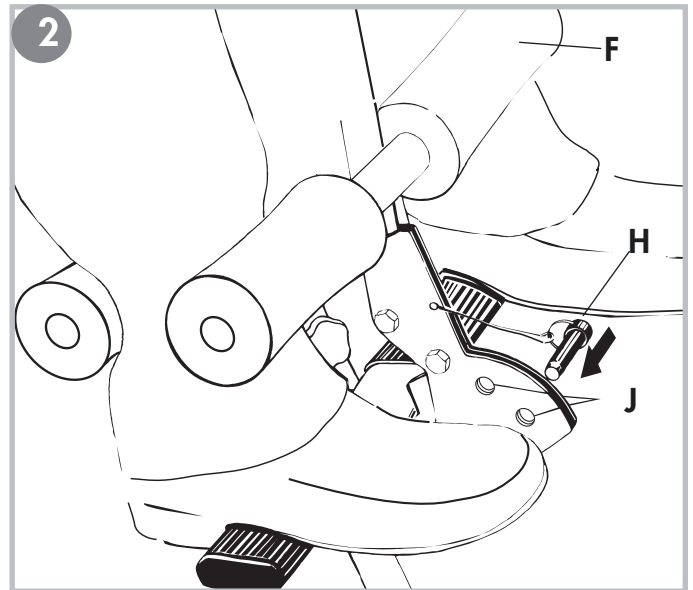
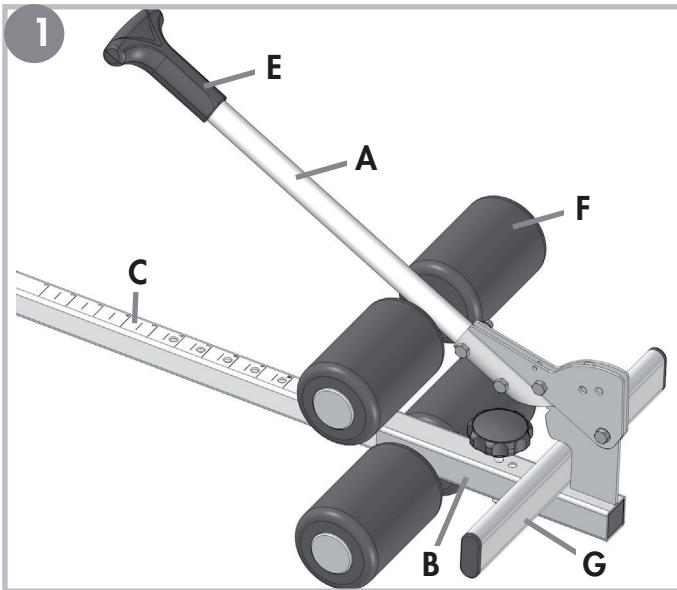

D Einstellung in ganze Stufen

- GB - Adjustment in whole increments
- F - Réglage en étapes complètes.
- NL - Instelling in hele treden.
- E - Ajuste de pasos enteros
- I - Regolazione per gradini interi
- PL - Nastawienie na całe stopnie
- CZ - Nastavení v celých stupních
- P - Ajuste em níveis inteiros
- DK - Indstilling i hel stigning
- RO - Reglarea în trepte complete
- H - Beállitás teljes fokozatba
- RUS - Установка на полную ступень
- S - Inställning i hela steg
- TR - Tam kademeli ayar

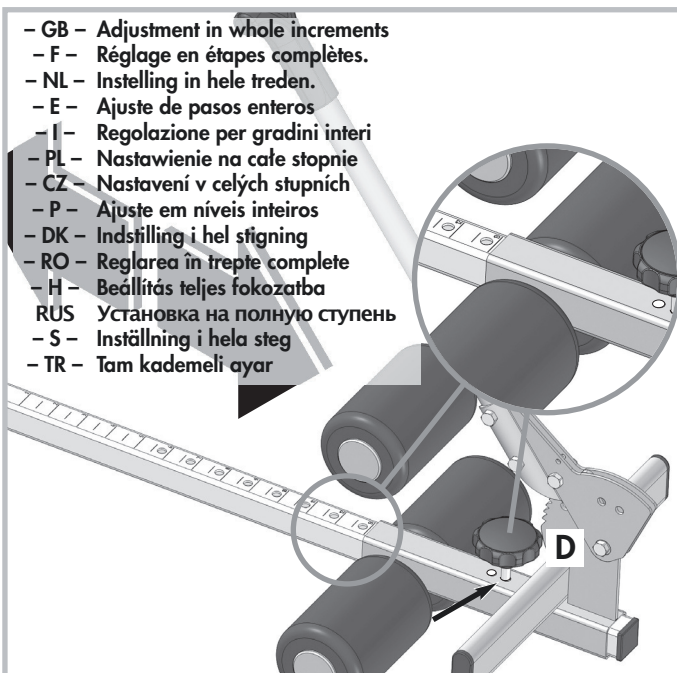

D Einstellung in halben Stufen

- GB - Adjustment in half increments.
- F - Réglage en demie étapes.
- NL - Instelling in halve treden.
- E - Ajuste de pasos medios.
- I - Regolazione per mezzi gradini
- PL - Nastawienie na połowy stopni
- CZ - Nastavení v půlkách stupňů
- P - Ajuste em meios níveis
- DK - Indstilling i halv stigning
- RO - Reglarea în jumătate de trepte
- H - Beállitás fél fokozatba
- RUS - Установка на половину ступени
- S - Inställning i halva steg
- TR - Yarım kademeli ayar

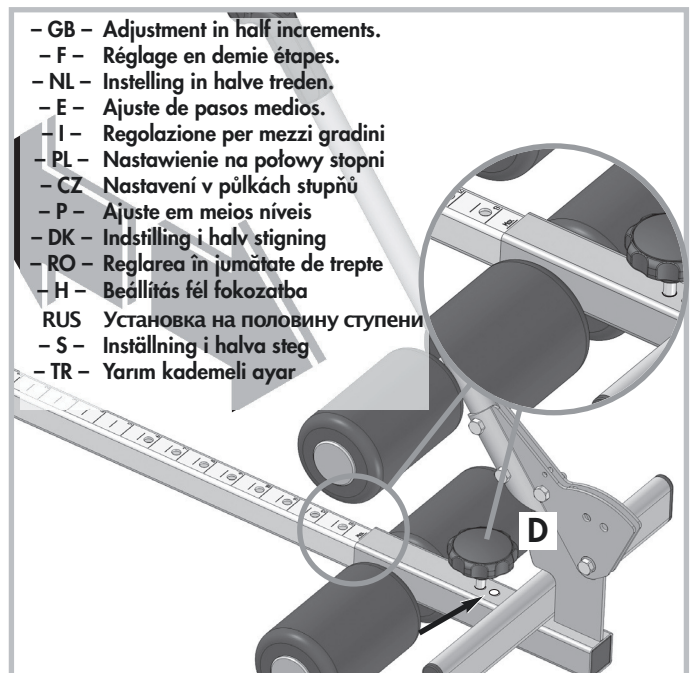

D Einstellen und Auspendeln des APOLLO

Am linken und rechten Standrohr des Gerätes befindet sich je eine Rasterverstellung (Bild 5), die den maximalen Neigungswinkel des Pendels begrenzt. Stellen Sie vor dem Training mit dem APOLLO den gewünschten maximalen Neigungswinkel ein. Es stehen sechs Positionen (Rasterlöcher) zur Verfügung: Position 1 begrenzt das Pendel in der waagerechten Position (Stellung II, Bild 4), die Positionen 2–5 in einem proportional größeren Neigungswinkel und die Position 6 in der steilsten „Über-Kopf-Lage“ (Stellung III, Bild 4). Anfänger sollten in jedem Fall mit einer geringen Neigung beginnen und sich allmählich an steilere Positionen herantasten.

Außerdem wird durch diese Sicherheitseinrichtung ein unbeabsichtigtes Herumschlagen des Pendels verhindert. **Unbedingt an beiden Rastersicherungen immer die gleiche Lochposition einstellen!**

Zur optimalen Nutzung des Gerätes ist eine exakte Einstellung der gesamten Fußeinheit notwendig. **Nehmen Sie das Einstellen daher sehr sorgfältig und immer im Beisein einer zweiten Person zur Hilfestellung vor, verfahren Sie wie folgt:** Zunächst den Stellkörper (B) in einer der unteren Lochungen des Fußrohres (C) durch Einsetzen des Steckgriffes (D) festsetzen. Die Klammern (F) nach Betätigung des Druckknopfes (E) durch Verschieben des Griffrohres (A) öffnen. Den Rücken gegen die Polsterfläche lehnen und mit den Füßen auf die Fußleisten (G) treten. Durch Druck auf das Griffrohr (A) in Richtung Körper die Klammern (F) schließen. **Achtung! Steckbolzensicherung nicht vergessen.**

Den Körper mit angelegten Armen zurücklehnen (Stellung I, Bild 3). Verlagern Sie jetzt Ihren Körperschwerpunkt, indem Sie zunächst einen Arm langsam bis über den Kopf bewegen. Falls sich das Pendel nicht aus seiner Ruhelage (Stellung I) bewegt, nehmen Sie den zweiten Arm zu Hilfe. Reicht auch dieses noch nicht aus, ist es notwendig, den Stellkörper (B) im nächst höheren Loch einzuset-

zen. Kontrollieren Sie stets vor Beginn Ihrer Übungen den festen Sitz des Stellkörpers. Tasten Sie sich auf diese Weise langsam an Ihren Idealpunkt heran und markieren oder merken Sie sich diesen Punkt (Rasterloch). Haben Sie Ihren Idealpunkt ermittelt, können Sie jetzt mit einem oder beiden Armen sowohl die Drehgeschwindigkeit steuern als auch das Pendel in jeder Position (Bild 4) bis zur eingestellten Neigungswinkel - Begrenzung anhalten. Durch leichten Zug an den Handgriffen können Sie sich aus der „Über-Kopf-Lage“ wieder in die Ausgangsstellung begeben.

Zur Einstellung des Stellkörpers bzw. für Ihre Übungen sollten Sie sich dennoch (auch aus Sicherheitsgründen) der Hilfe einer weiteren Person bedienen.

Warnhinweise

Entfernen Sie Hindernisse aus dem Schwenkbereich des Fußrohres und weisen Sie beistehende Personen auf mögliche Gefährdungen während der Übungen hin. **Nach Schließen der Klammer (F, Bild 2) unbedingt den Sicherheitssteckbolzen (H) in eines der Löcher (J) einsetzen. Trainieren Sie niemals ohne die Steckbolzensicherung!**

GB Adjustment and balancing of the APOLLO

At the left and right side of the device's frame there is an adjustment system (fig. 5) limiting the max. angle of inclination of the pendulum. Before taking up training with the APOLLO, adjust the desired angle of inclination. There are six positions (holes): Position 1 limits the pendulum in the horizontal position (position II, fig. 4), positions 2-5 in a proportionally higher angle of inclination, and position 6 in the steepest "head-down position" (position III, fig. 4). Beginners should start with a slight inclination and slowly work towards steeper positions.

This safety device also makes an overturning of the pendulum impossible. **Always use identical hole positions at both sides!**

For the optimum use of the device, an exact setting of the entire foot unit is necessary. **Therefore be very careful when making a setting and a second person should always be present to help, proceed as follows:** First lock the setting (B) in one of the bottom holes of the foot pipe (C) through entering the drive handle (D). Open the clamps (F) after activation of the push button (E) through pushing through the grip pipe (A). Lean the back against the upholstered surface and push with the feet on the foot bars (G). Through pressure on the grip pipe (A) in the direction of the body close the clamps (F). **Attention! Do not forget the locking pin clips.**

Lean back with the arms at your side (position I, fig. 3). Move the centre of gravity of the body by raising one arm slowly over the head. Should the swing not move from its resting position (position I) raise the second arm above the head, too. If the swing still does not move, insert the adjusting device (B) into the next hole upwards. Always ensure that the adjusting device is firmly locked in position before beginning to exercise. Determine your ideal point of balance by trial and error and mark or note the holes in question. If you have determined your ideal point, you can control the turning speed with one or with two arms and you can stop the pendulum

at any position (fig. 4) up to the adjusted angle of inclination. By pulling slightly on the hand grips, you can move from the "head downwards" position back into the starting position. When setting the balance of the swing, and during your exercises, the assistance of a second person is recommended for safety reasons.

Warnings

Remove obstacles from the foot tube's tilting range and inform assisting persons of possible risks during the exercises. **Always insert the locking pin (H) into one of the holes (J) after closing the bracket (F, fig. 2). Never exercise without the locking pin in position!**

Ersatzteilbestellung

- GB - Spare parts order
- E - Pedido de recambios
- CZ - Objednání náhradních dílů
- RO - Comandarea pieselor de schimb
- S - Reservdelar för

- F - Commande de pièces de rechange
- I - Ordine di pezzi di ricambio
- P - Encomenda de peças sobressalentes
- H - Pótalkatrész rajz
- TR - Yedek parça siparişi

- NL - Bestelling van reserveonderdelen
- PL - Zamówienie części zamiennych
- DK - Bestilling af reservedele
- RUS - Заказ запчастей



- D - Beispiel Typenschild - Seriennummer
- GB - Example Type label - Serial number
- F - Example Plaque signalétique - Numéro de serie
- NL - Bij voorbeeld Typeplaatje - Seriennummer
- E - Ejemplo Placa identificativa - Número de serie
- I - Esempio Targhetta tecnica - Numero di serie
- PL - Przykłady Tabliczka identyfikacyjna - Numer serii

- CZ - Příklad typového štítku - sériové číslo
- P - Exemplo placa de características - número de série
- DK - Eksempel type label - serienummer
- RO - Exemplu plăcuța de fabricație - seria
- H - Például a készülék ismertető címkéjén található sorozatszám
- RUS - Пример заводской таблички с серийным номером
- S - Exempel typskylt-serienummer
- TR - Etiket - Seri numarası örneği

- D - Geben Sie bei Ersatzteilbestellungen bitte die vollständige Artikelnummer, die Ersatzteilnummer, die benötigte Stückzahl und die Seriennummer des Gerätes an.
- GB - When ordering spare parts, always state the full article number, spare-part number, the quantity required and the S/N of the product.
- F - En cas de commande de pièces de rechange, nous vous prions de mentionner la référence article, le numéro de pièce de rechange, la quantité demandée et le numéro de série de l'appareil.
- NL - Vermeld bij de onderdelenbestellingen a.u.b. het volledige artikelnummer, het onderdeelnummer, het benodigde aantal en het serienummer van het apparaat.
- E - Indicar con los pedidos de piezas de repuesto el número completo del artículo, el número de la pieza de repuesto, las unidades solicitadas y el número de serie del aparato.
- I - Per l'ordinazione di parti di ricambio indicate il completo numero di articolo, della parte di ricambio, il numero di unit necessario nonchè il numero di serie dell'apparecchio.
- PL - Przy zamawianiu części zamiennych proszę podawać kompletny numer artykułu, numer części zamiennej i numer serii urządzenia.
- CZ - Při objednání náhradních dílů prosím udejte úplné číslo zboží, číslo náhradního dílu, potřebný počet kusů a sériové číslo přístroje.
- P - Ao encomendar peças sobressalentes, por favor indique o número completo do artigo, o número da peça sobressalente, o número de unidades necessárias e o número de série do aparelho.
- DK - Ved bestilling af reservedele skal du altid opgive det fuldstændige artikelnummer, nummeret på reservedelen, det ønskede antal og maskinens serienummer (se Håndtering).
- RO - La comandarea pieselor de schimb indicați numărul complet al articolului, numărul piesei de schimb, numărul de bucăți necesare și seria aparatului.
- H - Amikor pótalkatrészt rendel meg, adja meg a teljes cikkszámot, a pótalkatrész számot, a szükséges darabszámot és a gép sorszámát.

- RUS - Оформляя заказ на запчасти, указывайте полный артикульный номер, номер запасной детали, необходимое количество и серийный номер устройства.
- S - Ange alltid hela artikelnumret, respektive reservdelsnummer, antalet du behöver samt produktens serienummer.
- TR - Münferit siparişlerinizde lütfen ürün numarasını, yedek parça numarasını, ihtiyaç duyduğunuz adedi ve aletin seri numarasını eksiksiz belirtiniz.

Zubehörbestellung

- GB - Accessories

- E - Accesorios

- CZ - Příslušenství

- RO - Accesorii

- S - Beställa tillbehör

100 x 75 cm

140 x 80 cm

250 x 70 cm

220 x 110 cm

- F - Accessoires

- I - Accessori

- P - Acessórios

- H - Tartozékok rendelési

- TR - Aksesuar siparişi

07929-100

07929-200

07929-300

07929-400

- NL - Accessoires

- PL - Akcesoria

- DK - Tilbehør

- RUS - Аксессуары



Ersatzteilbestellung

		07426-700 Apollo
①	1x	94360406
②	1x	94316592
③	1x	94316593
④	1x	94604511
⑤	1x	94316594
⑥	1x	94316595
⑦	1x	94604512
⑧	1x	94604513
⑨	1x	94316596
⑩	2x	97100592
⑪	1x	94316597
⑫	1x	97100429
⑬	2x	10100023
⑭	1x	94316598
⑮	4x	10118042

		07426-700 Apollo
⑯	1x	94604514
⑰	1x	13100000
⑱	2x	13100008
⑲	1x	13100006
⑳	1x	10103077
㉑	2x	70132715
㉒	4x	10100022
㉓	4x	10100044
㉔	2x	10100040
㉕	4x	70132716
㉖	2x	70132298
㉗	2x	97200474
㉘	2x	70132717
㉙	2x	70132297
㉚	1x	91380119

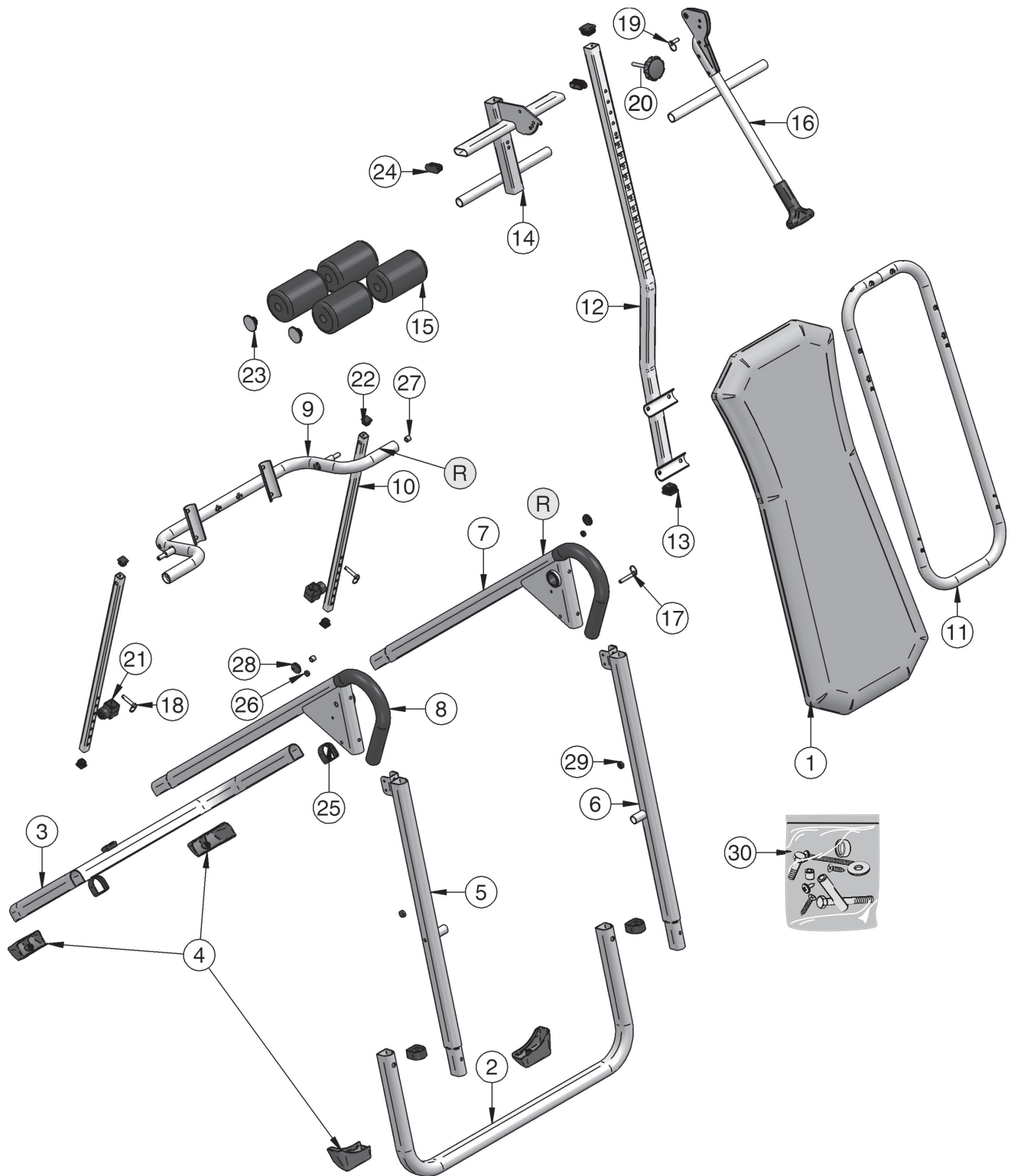



HEINZ KETTLER GmbH & Co. KG · Postfach 1020 · D-59463 Ense-Parsit
www.kettler.de

Free Manuals Download Website

<http://myh66.com>

<http://usermanuals.us>

<http://www.somanuals.com>

<http://www.4manuals.cc>

<http://www.manual-lib.com>

<http://www.404manual.com>

<http://www.luxmanual.com>

<http://aubethermostatmanual.com>

Golf course search by state

<http://golfingnear.com>

Email search by domain

<http://emailbydomain.com>

Auto manuals search

<http://auto.somanuals.com>

TV manuals search

<http://tv.somanuals.com>