

KETTLER

Montageanleitung und Handhabungshinweise Fahrrad-Kindersitz „FLIPPER“

Art.-Nr. 08947-570

Abb. ähnlich



D

GB

USA

F

NL

Der Umwelt zuliebe: wir drucken auf 100% Altpapier!



GB

USA

Assembly Instructions

Please read these instructions carefully before the assembly and first use. You will get important information on your safety as well as the use and maintenance of the child's seat. Retain these instructions for information and for maintenance works as well as orders for spare parts.

KETTLER's child's seat was designed in compliance with applicable safety regulations and manufactured under permanent quality control. The knowledge gained in this process is used to constantly improve and develop our products. In order to offer our customers the very best in quality, we reserve the right to make technical changes at

any time. Should you have the need of assistance, please contact your dealer.

For Your Safety

- Only use this bicycle child's seat for its intended purpose, i.e. only mount it above the bike's rear axle by means of the included mounting parts and only use it for the transport of children.
- The seat is suitable for children who can already **sit alone** (about 9 months), and may be loaded with a maximum weight of **22 kg including luggage**. (Check regularly with the age of the child).
- This child's bicycle seat is **not** suitable for fully sprung bicycles.
- The child's seat can be used for bicycles with a minimum wheel diameter of 26 inches; the diameter of the frame tube must be 28, 30, 32, 35 or 40 mm.
- Any other use is inadmissible and may even be dangerous. The manufacturer cannot be held liable for damage caused by unauthorized use.
- The bicycle used must be safe and correspond to the Road Traffic Licensing Regulations valid in your country. Please make enquiries if there are regulations concerning the transport of children.
- If you have a special bicycle structure please ask your dealer if your bike is suitable for the use of a child's seat.
- The bicycle must be suited for accepting such additional loads. Furthermore, the admissible total weight of the bicycle including child and child's seat must not be exceeded. If necessary, ask your bicycle manufacturer or supplier regarding the bicycle's carrying capacity.
- If you transport your bicycle on a luggage rail on your car, you should dismount the child's seat from your bicycle to avoid exceeding the carrying capacity of the luggage rail.
- When attaching the seat to a bicycle that has a saddle stem with suspension please take into account the distance between the seat and the suspension spring. You should ensure that the child's fingers cannot reach the spring thus avoiding the **danger of injury**.
- Please note that the riding behaviour of the bicycle changes when the child's seat is used (irrespective of child being transported or not). Owing to the higher centre of gravity the bicycle's behaviour may change unfavourably and the bicycle's dirigibility may be impaired. For this reason, ride carefully – in particular with regard to braking and evading manoeuvres. Also avoid riding with one hand only.
- Pay attention that the child does not handle any objects (e.g. toys) which might get caught in the wheels. Clothes or extremities of the child should never be able to get caught in turning parts or in the brake and transmission system.
This should be checked regularly as the child grows older.
- Protect your child from sharp edges of your bicycle, from worn cables and other parts that might lead to injuries.
- Before going on a ride, and during breaks, you should check that the seat is firmly attached, and also check all components for potential damage and loose connections (screws, connections, safety belts etc.).
- **Attention:** Only transport the child with the safety belt **correctly and firmly fastened** and the foot straps closed. Have a check during breaks that those safety devices are still in place.
- Even if no child is carried, close the seat belt to avoid it getting caught in turning parts or catching on items that are passed during the ride.
- Pay attention to suitable and sufficiently warm clothing of your child. Children who are sitting still normally cool down faster than the rider.
- We recommend that adult and child wear suitable helmets.
- Adjust the headrest so that its upper edge matches the child's ear level.
- If in doubt or if you have any further questions do not hesitate to contact your specialized dealer.
- **Attention:** Do not attach additional luggage to the child's seat. If necessary, use a carrier for the front axle in order to obtain a balanced load. Please note that the carrying capacity of bicycle and child's seat are not exceeded.
- **Attention:** The seat must not be modified. The child's bicycle seat meets all required safety regulations. Repair works done by non-experts and alterations to the construction (dismounting original parts, attachment of parts without approval etc.) may cause harm to the user.
- **Attention:** Please note that the riding behaviour of the bicycle may change with a child in the seat, especially

regarding balance, steering and braking. Ask the child to sit quietly. Sudden weight transfers by the child may considerably affect your safety during the ride.

- **Attention:** Never park the bicycle with the child still in its seat.
- **Attention:** Do not use the seat if one of its components is defective. Damaged components may jeopardize your or the child's safety. Before going on a ride you should check all components for potential damage and loose connections (screws, connections, safety belts etc.). Damaged or worn components must be replaced immediately. Only use original KETTLER spare parts.
- **Attention:** In case of extreme weather conditions please check if the seat can be used by the child, as for example the seat may become very hot when there is strong solar radiation, or if the temperature is far below freezing point the skin may stick to the seat or its components.

Assembly

- The child's seat must be positioned such that it is not in contact with the luggage carrier. The distance between luggage carrier and tube shackle must be min. 25 mm.
- Fix the tube shackle parallel to the ground. This results in a seat which is slightly inclined towards the rear such that the child may not slide out of the seat. The seat back is slightly inclined to the rear.
- The load centre (marked by a red point) may only be within 10 cm behind the wheel hub (explained in detail below).
- In case of saddles with uncovered springs the latter have to be covered as a protection against bruises (e. g. art. nr. 08947-690).
- Further to that the rear wheel is provided with an additional cover on the spokes or a protective device to prevent dresses from getting mingled with the spokes.
- Tighten all screws with a torque of approx. 6 Nm. Check the tight fit of all screwed connections after assembly.
- Please check whether all parts of the bike operate correctly with the set fitted in place (e.g. steering and brakes).

Service and maintenance

- Always use environmentally friendly substances, never aggressive or caustic ones, for cleaning and servicing the child's bicycle seat.
- If necessary you may also clean the safety belts. In this case it is especially important not to use aggressive substances! Usually weak washing-up water or a mild detergent will be sufficient.
- If seat or clothes are damp the colour of the seat may possibly mark pale coloured clothes due to friction.

Accessories

- If you want to attach the seat to another bicycle, you can order a second carrier for the child's seat. (item no. 8947-633).
- To secure the child's seat from theft, a cylinder lock can be inserted into the seat support bracket. The lock (type K.01.32.G1) is not supplied with the seat. The lock is obtainable from: Firma P.C. Fischer, Kaiserstraße 126, D-58300 Wetter/Ruhr, tel. (0) 23 35/42 64, fax (0) 23 35/58 46

Note on Assembly

Assembly must be carried out carefully by **an adult**.

Carefully read these mounting instructions before beginning with the work itself. The individual steps are additionally explained in the sequence of figures by means of symbols, in some cases a text mark indicates that a written explanation is available. Strictly follow the individual mounting steps to ensure a safe use and operation of the unit.

For technical reasons, we reserve the right to carry out preliminary assembly work (e.g. addition of tubing plugs).

3 Years Guarantee

- KETTLER guarantees that this product has been manufactured with the greatest care using materials of the highest



Assembly Instructions

quality. However, should you have reason for complaint, please contact your dealer. Do not forget to submit your receipt of payment. The guarantee commences on the date of purchase. Entitlement to service under the guarantee does not recommence if repairs are carried out.

- Damage caused by incorrect treatment or the use of force is not covered by this guarantee.
- Similarly, the manufacturer is not liable for damage to the product caused by environmental factors (e.g. air or (rain)water pollution). Any costs arising from the repair of damage of this kind will not be assumed by the manufacturer.

List of spare parts page 23-24

When ordering spare parts, always state the full article number, spare-partnumber, the quantity required and the S/N of the product (see handling).

Example order: Art. no. 08947-570 / spare-part no. 96600201 / 2 pieces / S/N Please keep original packaging of this article, so that it may be used for transport at a later date, if necessary.

Goods may **only** be returned after prior arrangement and in (internal) packaging, which is safe for transportation, in the original box if possible.

It is important to provide a detailed defect description / damage report!

Important: spare part prices do not include fastening material; if fastening material (bolts, nuts, washers etc.) is required, this should be clearly stated on the order by adding the words „with fastening material“.

Waste Disposal

KETTLE products are recyclable. At the end of its useful life please dispose of this article correctly and safely (local refuse sites).



KETTLE (GB) Ltd.

Merse Road · North Moons Moat · Redditch, Worcestershire B98 9HL · Great Britain

<http://www.kettler.co.uk>



KETTLE International Inc.

1355 London Bridge Road · VA 23450 Virginia Beach USA

<http://www.kettlerusa.com>

Download from www.Somanuals.com. All Manuals Search And Download.

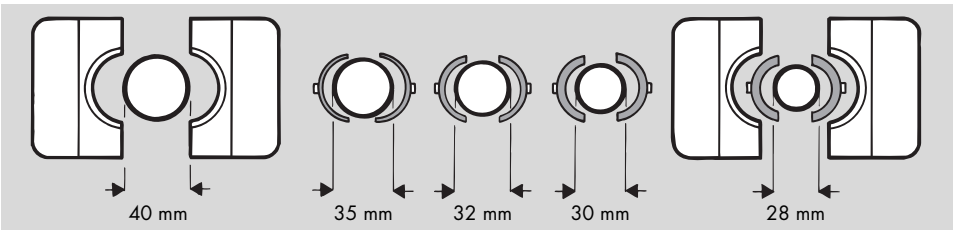
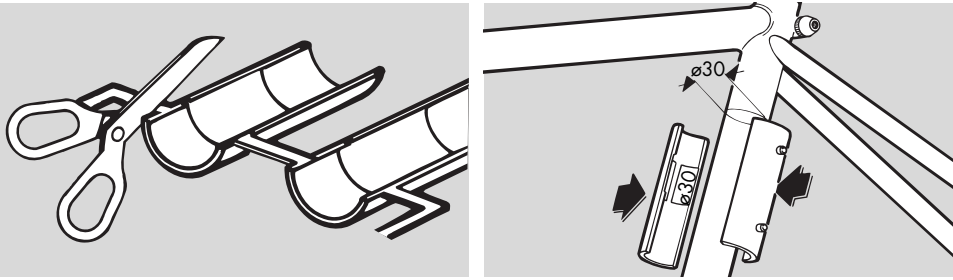

2a Zubehörmontage

Schloss gehört nicht zum Lieferumfang.

- (GB) Accessory assembly. Lock not included.
- (F) Montage des accessoires. La serrure ne fait pas partie du domaine de livraison.
- (NL) Het slot behoort niet tot de standaarduitrusting.

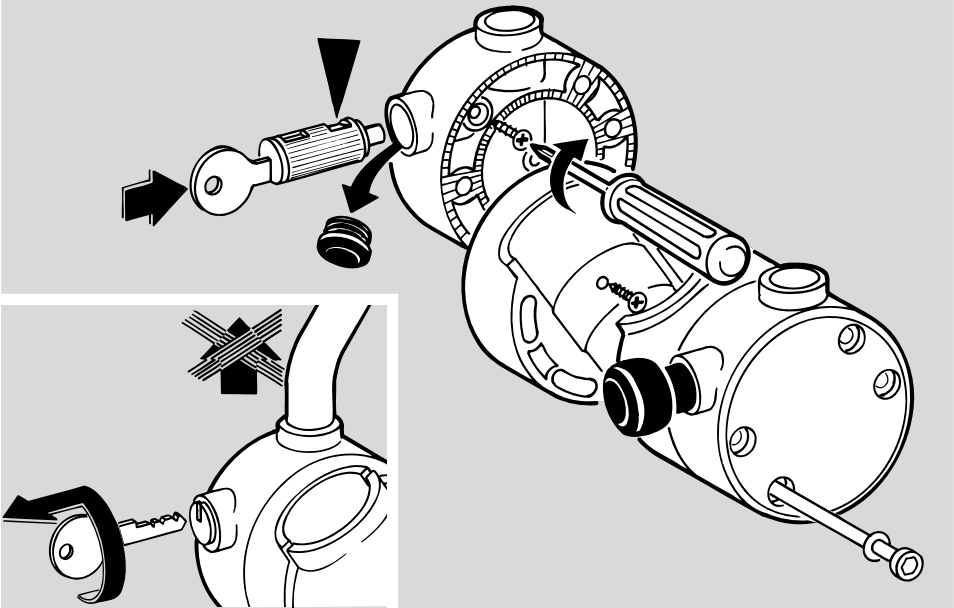

2b

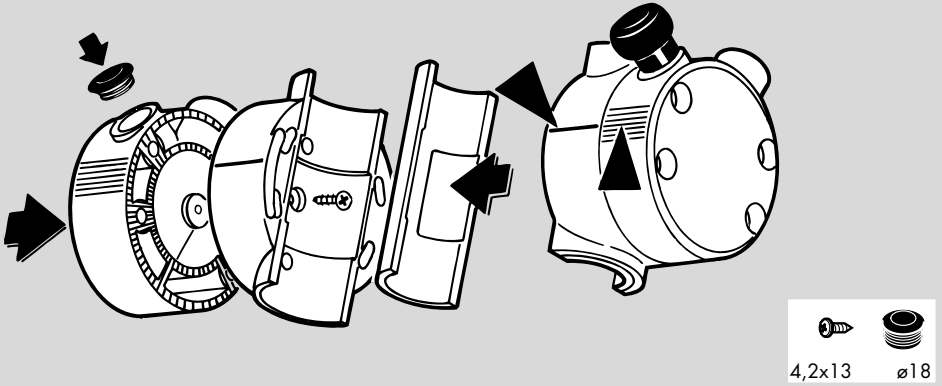

3

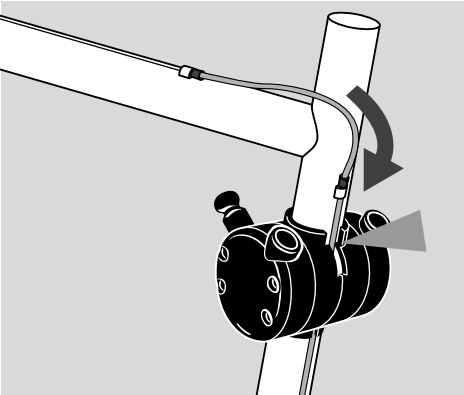

4

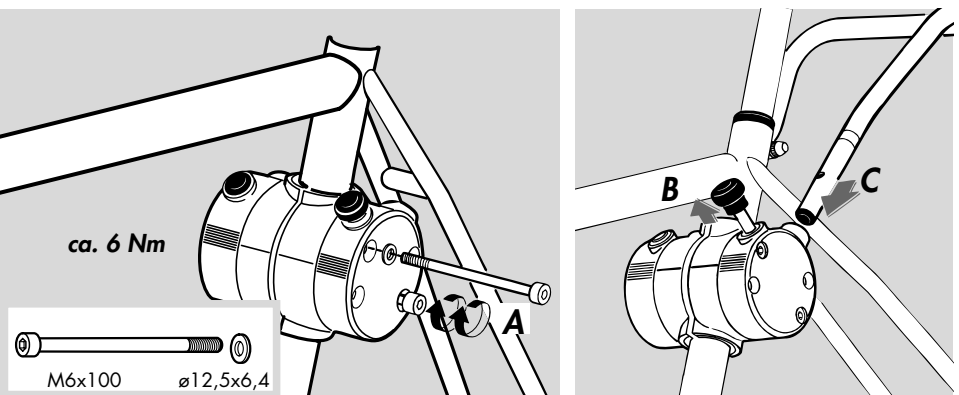

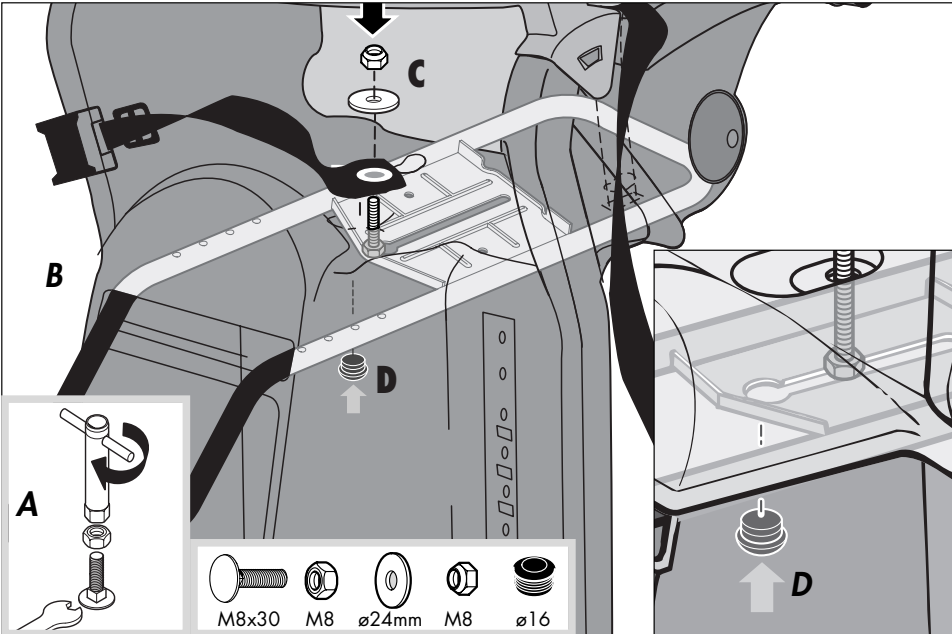
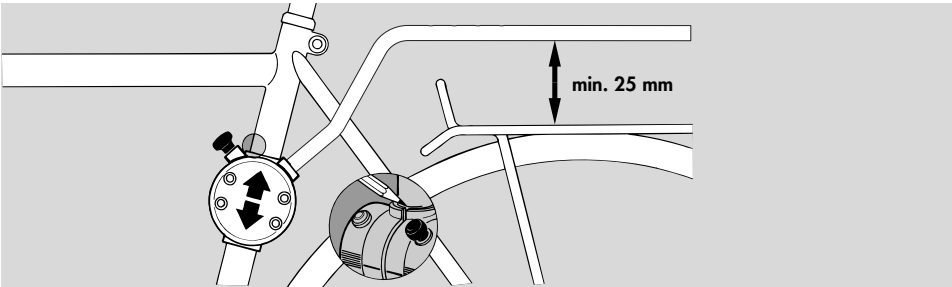
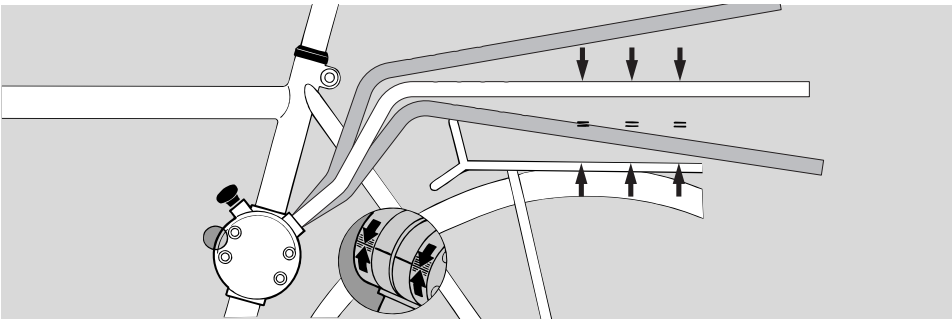

6b

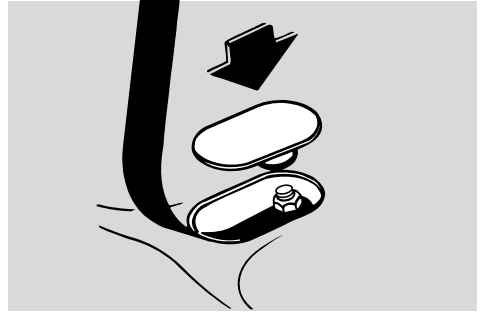
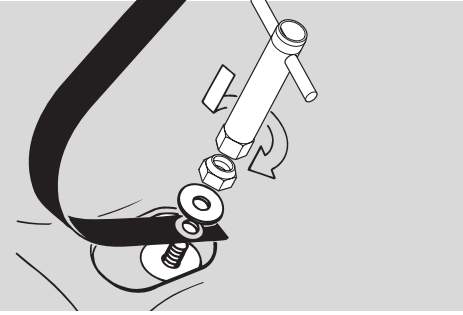

7

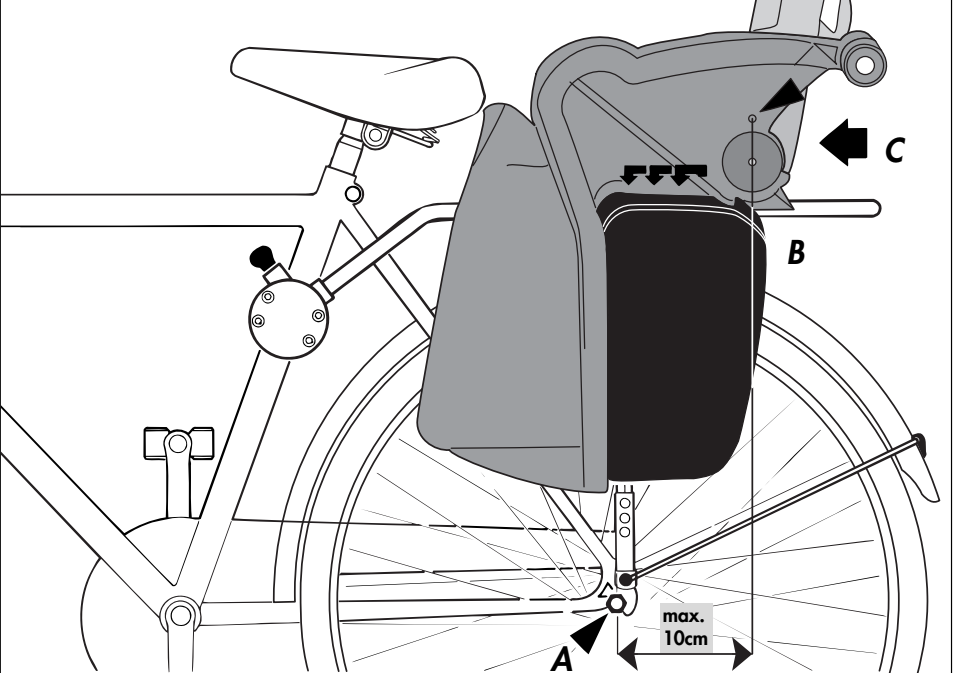
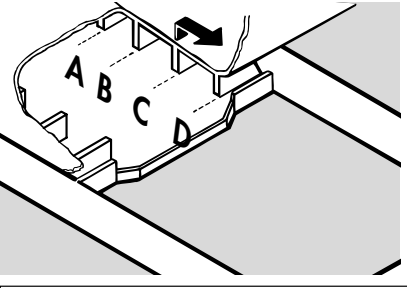

8a

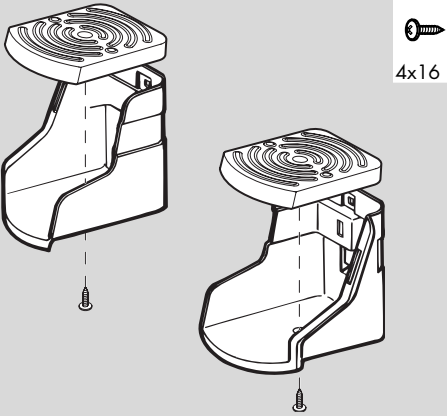

- D** Nur bei sehr kleinen Kindern zu verwenden.
- GB** Only use for very small children.
- F** Veuillez seulement utiliser pour des enfants très jeunes.
- NL** Alleen gebruiken bij heel kleine kinderen.

8b

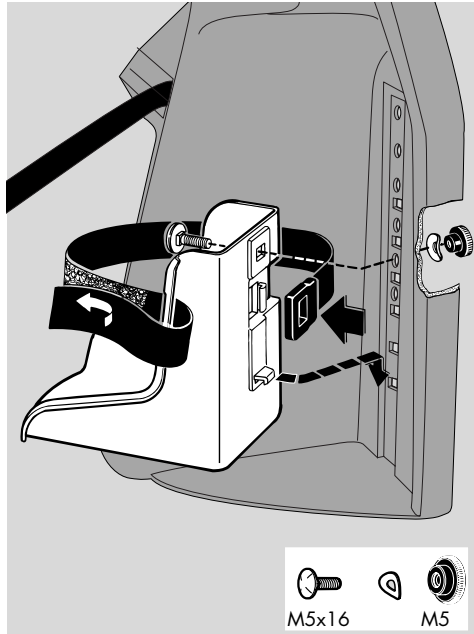

9

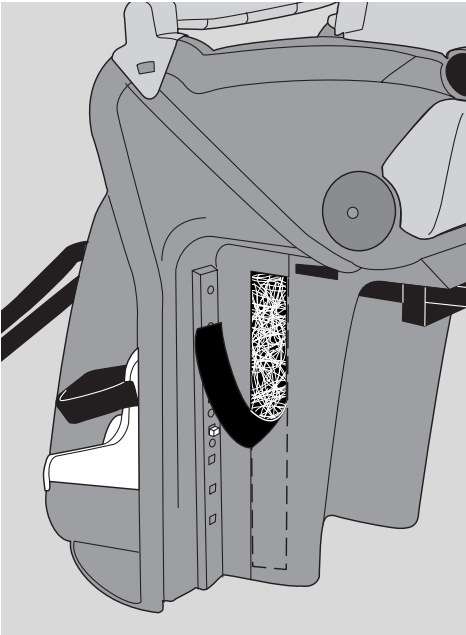

10 Rechte und linke Tasche sind unterschiedlich

- GB** Right and left bag different.
- F** Les sac droit et gauche sont différents.
- NL** De linker en rechter tas zijn verschillend.

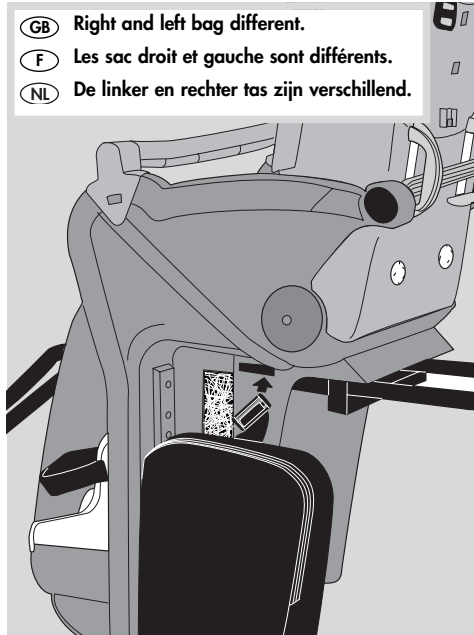

Handhabungshinweise

GB Handling

F Indications relatives à la manipulation

NL Bedieningsinstructies

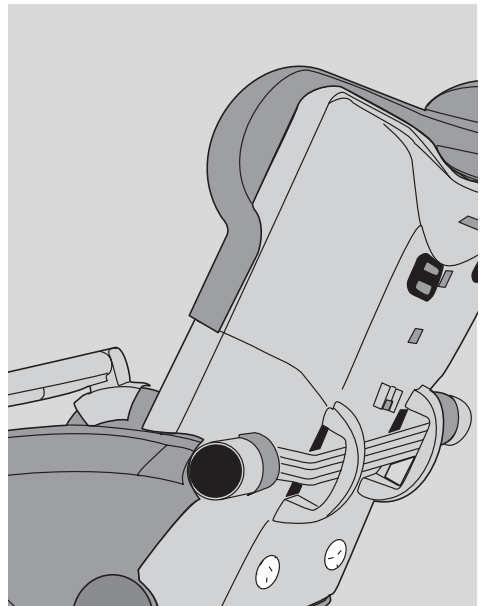
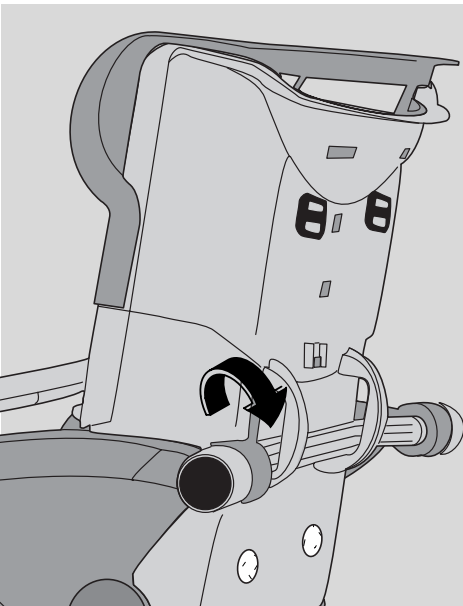
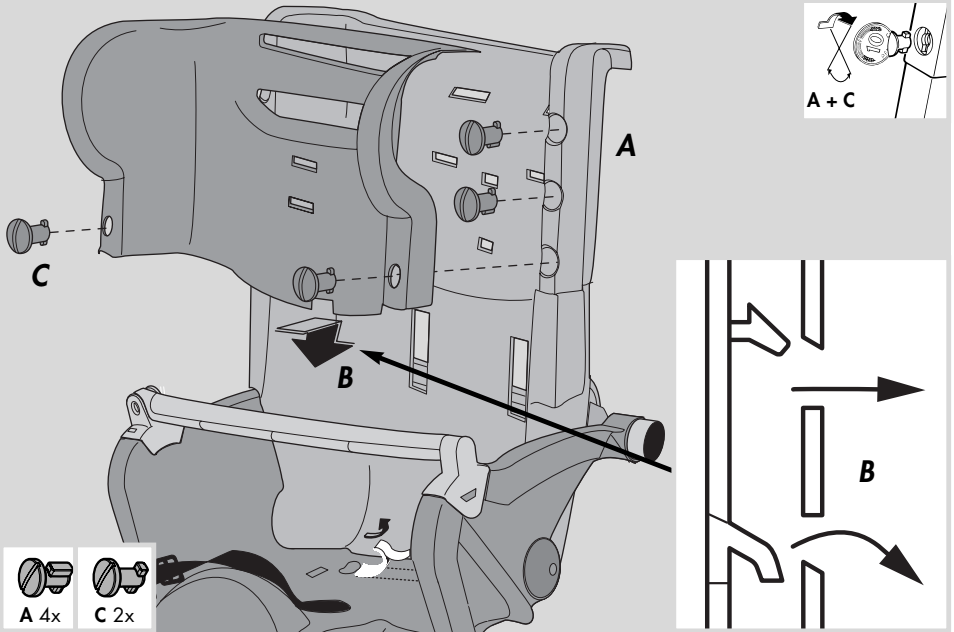

Handhabungshinweise

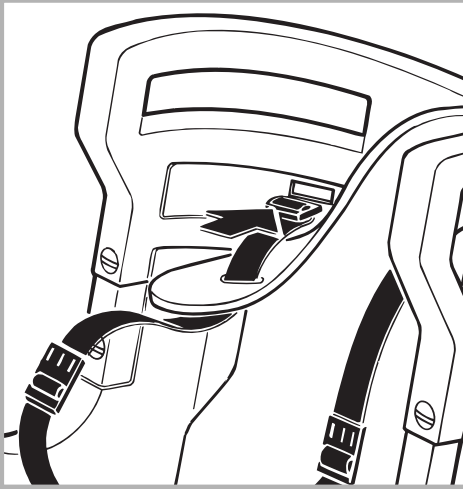

- (D) Die Schultergurte 14 lassen sich gemäß der Körpergröße des Kindes in der Höhe verstellen.
- (GB) The shoulder straps (14) can be adjusted in accordance with the child's tallness.
- (F) Les ceintures pour les épaules sont réglables (14) en hauteur en fonction de la taille de l'enfant.
- (NL) De schoudergordels (14) kunnen in overeenstemming met de lichaamsgrootte van het kind in de hoogte versteld worden.

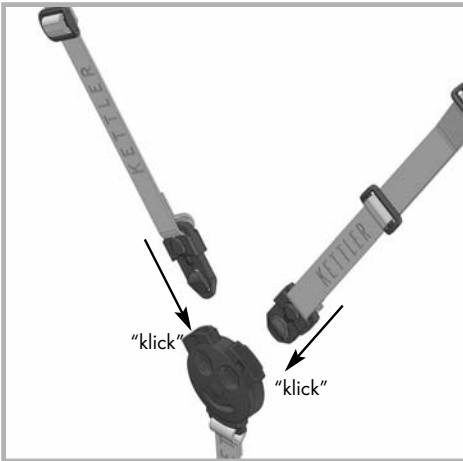

- (D) Achten Sie unbedingt auf das korrekte Anlegen der Sicherheitsgurte!
Die Schultergurte lassen sich gemäß der Körpergröße des Kindes in der Höhe verstellen.
- (GB) It is urgently required that you pay attention to the proper fastening of the safety belts.
The shoulder straps can be adjusted in accordance with the child's tallness.
- (F) Veiller à ce que la ceinture de sécurité soit bien attachée.
Les ceintures pour les épaules sont réglables en hauteur en fonction de la taille de l'enfant.
- (NL) Let er absoluut op, dat de veiligheidsgordels goed aangelegd zijn.
De schoudergordels kunnen in overeenstemming met de lichaamsgrootte van het kind in de hoogte versteld worden.

Typenschild



- D** Beispiel Typenschild - Seriennummer
- GB** Example Type label - Serial number
- F** Exemple Plaque signalétique - Numéro de serie
- NL** Bij voorbeeld Typeplaatje - Seriennummer



- D** Geben Sie bei Ersatzteilbestellungen bitte die vollständige Artikelnummer, die Ersatzteilnummer, die benötigte Stückzahl und die Seriennummer des Gerätes an.
- GB** When ordering spare parts, always state the full article number, spare-partnumber, the quantity required and the S/N of the product.
- F** En cas de commande de pièces de rechange, nous vous prions de mentionner la référence article, le numéro de pièce de rechange, la quantité demandée et le numéro de série de l'appareil.
- NL** Vermeld bij de onderdelenbestellingen a.u.b. het volledige artikelnummer, het onderdeelnummer, het benodigde aantal en het serienummer van het apparaat.

Actual size

Step 4

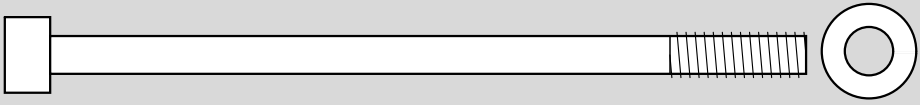

M6x100

ø12.5x6,4

Step 6a

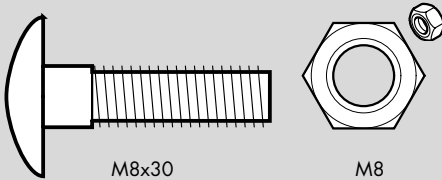

M8x30

M8

Step 6b

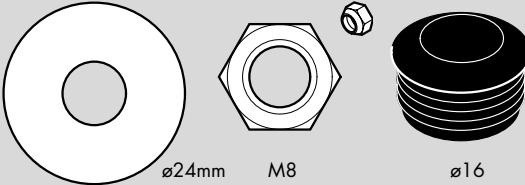

ø24mm

M8

ø16

Step 8a

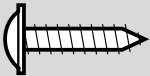

4x16

Step 8b

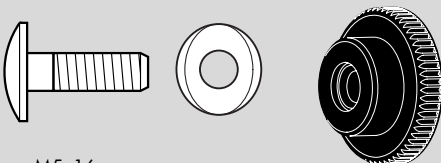

M5x16

M5

Ersatzteilbestellung

GB Spare parts order

F Commande de pièces de rechange

NL Bestelling van reserveonderdelen

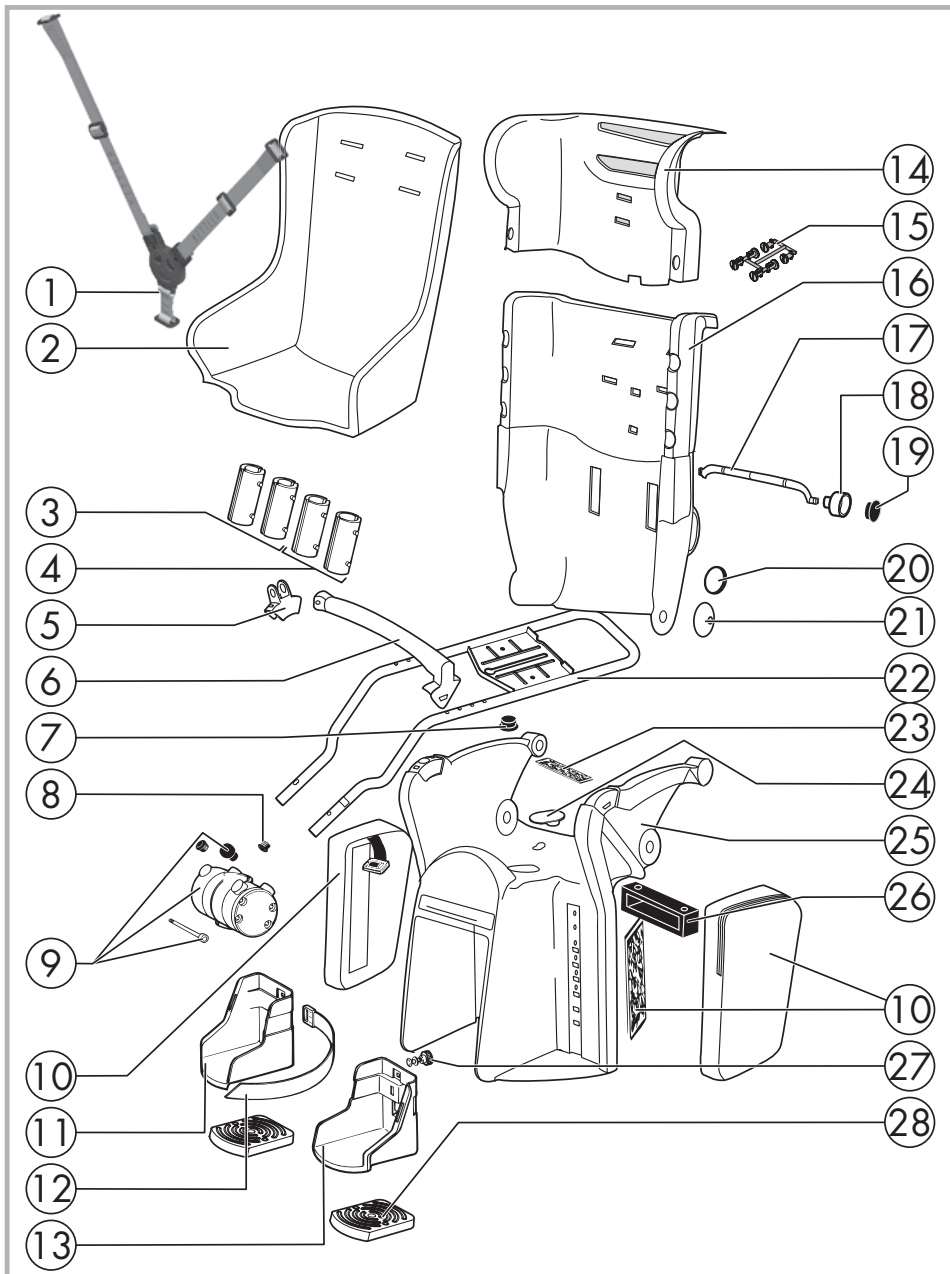

Ersatzteilbestellung

Pos.- Nr.	Fahrradkindersitz FLIPPER Bezeichnung	Stück	08947-570 weiß/grau Bestell-Nr.
1	Gurtsystem (kpl.)	1	98585105
2	Polster	1	58947570
3	Ausgleichsbuchsensatz ø28 mm + 30 mm	1	70122675
4	Ausgleichsbuchsensatz ø32 mm + 35 mm	1	70122677
5	Gelenkstück (3139)	1	70122869
6	Handbügel (3134)	1	70122864
7	Stopfen	1	10100094
8	Stopfen ø16 mm	2	10100000
9	Beipack Nr.51 Kindersitzhalterung kpl.	1	98580510
10	Beipack Nr.70 Seitentaschen kpl.	1	98580701
11	Fußstütze rechts (1796)	1	70122813
12	Klettverschlussband	2	42108007
13	Fußstütze links	1	70122812
14	Kopfstütze (3133)	1	70122863
15	Beipack Nr.71 Verbindungsbolzen	1	98580710
16	Rückenteil (3132)	1	70122862
17	Verstellhebel (3135)	1	70122866
18	Handrad (3136)	2	70122867
19	Stopfen ø35 mm	2	10100195
20	Reflektor	2	33901127
21	Gelenkkappe (3137)	2	70122868
22	Rohrbügel mit Stopfen ø16 mm	1	91960097
23	Klettband 20x100 mm	1	96600202
24	Schraubenabdeckung (2347)	1	70122480
25	Sitz (3131)	1	70122861
26	Rohrbügelführung (3138)	1	70122831
27	Rändelmutter M5	2	10104000
28	Adapter (4288)	2	70122814
29	Schraubenbeutel kpl. Beipack 71	1	98580770

docu 602my/08.09



Free Manuals Download Website

<http://myh66.com>

<http://usermanuals.us>

<http://www.somanuals.com>

<http://www.4manuals.cc>

<http://www.manual-lib.com>

<http://www.404manual.com>

<http://www.luxmanual.com>

<http://aubethermostatmanual.com>

Golf course search by state

<http://golfingnear.com>

Email search by domain

<http://emailbydomain.com>

Auto manuals search

<http://auto.somanuals.com>

TV manuals search

<http://tv.somanuals.com>