

1-888-340-0482
Monday-Friday
8:30-5:30 Central Time



Keys Fitness Products, L.P.
4009 Distribution Dr.
Suite 250
Garland, Texas 75041

CardioMax

580 Recumbent

OWNER'S MANUAL

QUESTIONS?

Call Our Toll Free
Keys Fitness Helpline
1-888-340-0482

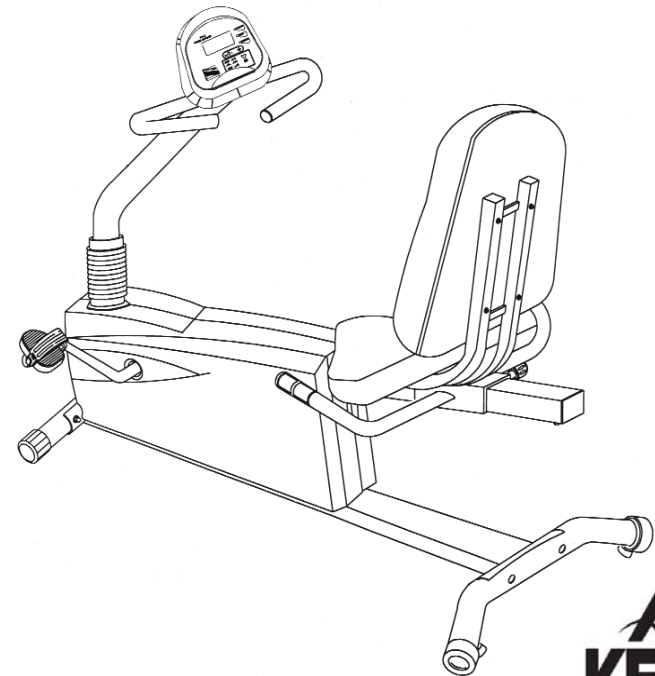

CAUTION!

Please read the precautions and instructions in this manual before using this equipment. Please save this manual for future reference.

Keys Fitness Products, L.P.
P.O. Box 551239
Dallas, Texas 75355-1239



Keys Fitness is committed to quality products that demonstrate our commitment to excellence!

**Keys Exercise Bike
Model: CM580R**

Questions?

Please call if:

- you need assistance about operating your exercise bike
- parts are missing
- parts become worn or need to be replaced

**1-888-340-0482
Monday-Friday
8:30-5:30 Central Time**

When requesting information please have the following available:

- The Name
- The Model
- The Part Number
- The Description

KEYS FITNESS PRODUCTS, LP - LIMITED WARRANTY

PRODUCT:	KEYS CARDIOMAX 580 RECUMBENT BIKE
HOME USE WARRANTY:	Frame 2 Years
	Parts 1 Year
	Labor None

This Limited Warranty applies in the United States and Canada to products manufactured or distributed by Keys Fitness Products, LP ("Keys") under the KEYS brand name. The warranty period to the original purchaser is listed above in the table.

Keys warrants that the Product you have purchased for use from Keys or from an authorized Keys reseller is free from defects in materials or workmanship under normal use during the warranty period. Your sales receipt, showing the date of purchase of the Product, is your proof of purchase. This warranty only extends to you, the original purchaser. It is not transferable to anyone who subsequently purchases the Product from you. It excludes expendable parts. This Limited Warranty becomes VALID ONLY if the product is purchased through a Keys Fitness authorized dealer unless otherwise authorized by Keys Fitness in writing.

During the warranty period Keys will repair or replace (at Keys' option) the product if it becomes defective, malfunctions, or otherwise fails to conform with this Limited Warranty under normal use. In repairing the Product, Keys may replace defective parts, or at the option of Keys, serviceable used parts that are equivalent to new parts in performance. All exchanged parts and Products replaced under this warranty will become the property of Keys. Keys reserves the right to change manufacturers of any part to cover any existing warranty.

This warranty DOES NOT COVER shipping charges, export taxes, custom duties and taxes, or any other charges associated with transportation of the parts or Product.

To obtain warranty service, you must contact a Keys authorized retailer, service technician or Keys Fitness at our phone numbers located in this manual. Any parts determined to be defective must be returned to Keys to obtain warranty service. You must prepay any shipping charges, export taxes, custom duties and taxes, or any other charges associated with transportation of the parts or Product. In addition, you are responsible for insuring any parts or Product shipped or returned. You assume the risk of loss during shipment. You must present Keys with proof-of-purchase documents (including the date of purchase). Any evidence of alteration, erasing or forgery of proof-of-purchase documents will be cause to void this Limited Warranty.

This warranty does not extend to any product not purchased from Keys or from an authorized Keys reseller. This Limited Warranty does not extend to any Product that has been damaged or rendered defective; (a) as a result of accident, misuse, or abuse; (b) by the use of parts not manufactured or sold by Keys; (c) by modification of the Product or normal wear and tear; (d) operation on incorrect power supplies; or (e) as a result of service by anyone other than Keys, or an authorized Keys warranty service provider. Product on which the serial number has been defaced or removed is not eligible for warranty service. Should any Product submitted for warranty service be found ineligible, an estimate of repair cost will be furnished and the repair will be made if requested by you upon Keys' receipt of payment or acceptable arrangements for payment.

EXCEPT AS EXPRESSLY SET FORTH IN THIS WARRANTY, KEYS MAKES NO OTHER WARRANTIES, EXPRESSED OR IMPLIED, INCLUDING ANY IMPLIED WARRANTIES OF MERCHANTABILITY AND FITNESS FOR A PARTICULAR PURPOSE. KEYS EXPRESSLY DISCLAIMS ALL WARRANTIES NOT STATED IN THIS LIMITED WARRANTY. ANY IMPLIED WARRANTIES THAT MAY BE IMPOSED BY LAW ARE LIMITED TO THE TERMS OF THIS LIMITED WARRANTY. NEITHER KEYS NOR ANY OF ITS AFFILIATES SHALL BE RESPONSIBLE FOR INCIDENTAL OR CONSEQUENTIAL DAMAGES. SOME STATES DO NOT ALLOW LIMITATIONS ON HOW LONG AN IMPLIED WARRANTY LASTS OR THE EXCLUSION OR LIMITATION OF INCIDENTAL OR CONSEQUENTIAL DAMAGES, SO THE ABOVE LIMITATIONS OR EXCLUSION MAY NOT APPLY TO YOU. This Limited Warranty gives you specific legal rights and you may also have other rights that may vary from state to state. This is the only express warranty applicable to Keys-branded products. Keys neither assumes nor authorizes anyone to assume for it any other express warranty.

PLEASE SEND IN THE ATTACHED WARRANTY CARD WITHIN TEN (10) DAYS OF PURCHASE TO REGISTER YOUR EXERCISE BIKE WITH KEYS FITNESS PRODUCTS, LP.

MAIL WARRANTY CARD TO:
KEYS FITNESS PRODUCTS, PO BOX 551239, DALLAS, TX 75355

Before You Start

Thank you for purchasing a Keys exercise bicycle! This quality product you have chosen was designed to meet your needs for cardiovascular exercise.

Prior to assembly, remove components from the box and verify that all the listed parts were supplied. Assembly instructions are described in the following steps and illustrations.

Important Safety Information **WARNING!**

- 1) Before using this exercise bicycle or starting any exercise program, consult your physician. This is especially important for persons over the age of 35 and/or persons with pre-existing health problems. Keys Fitness Products LP assumes no responsibility for personal injury or property damage sustained by or through the use of this product.
- 2) To reduce the risk of electrical shock, burns, fire or other possible injuries to the user, it is important to review this manual and the safety precautions before operation.

Safety Precautions and Tips

It is the owner's responsibility to ensure that all users of this exercise bike have read the Owner's Manual and are familiar with warnings and safety precautions.

- This exercise bike has a user maximum capacity of 300 pounds.
- The CardioMax Exercise bike should only be used on a level surface and is intended for indoor use only. It should not be placed in a garage, patio or near water. Keys recommends a bicycle mat be placed under the bicycle to protect floor or carpet and for easier cleaning.
- Wear comfortable, good-quality walking or running shoes and appropriate clothing. Do not use this exercise bike with bare feet, sandals, socks or stockings!
- Always examine your exercise bike before using to ensure all parts are in working order.
- Do not leave children unsupervised near or on the exercise bicycle.
- Never operate the exercise bicycle where oxygen is being administered or where aerosol products are being used.
- Never insert any object or body parts into any opening.
- Service to your CardioMax exercise bike should only be performed by an authorized service representative, unless authorized and/or instructed by a Keys technician. Failure to follow these instructions will void the warranty.

Assembly Parts

Before assembly, please look at the drawing below and familiarize yourself with the parts labeled.

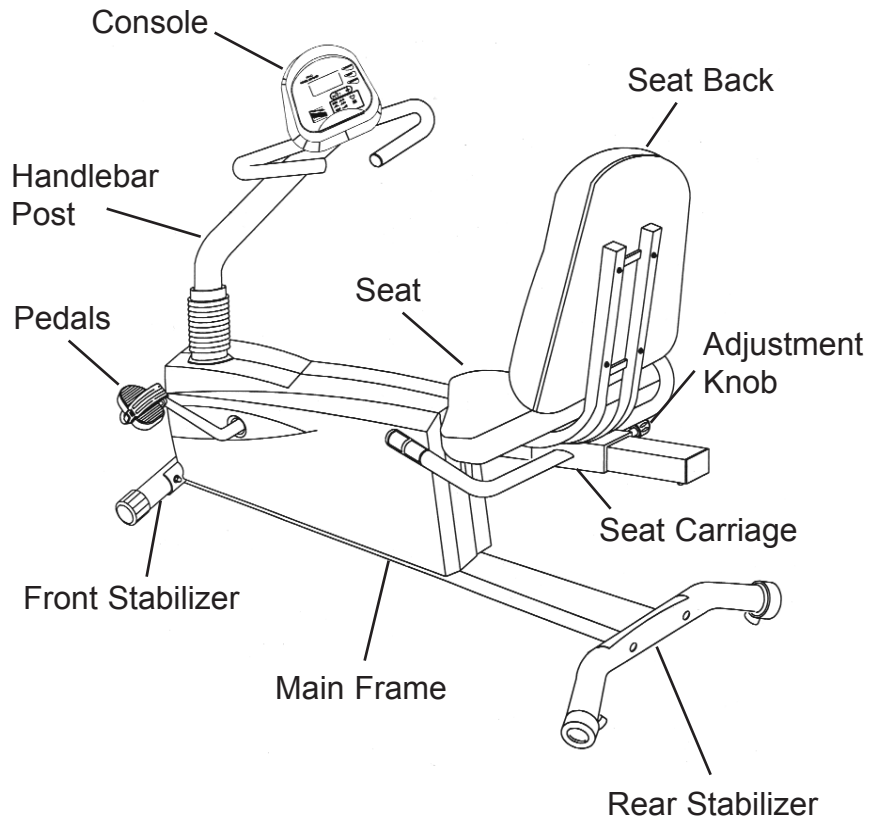

Your console instructions are included in a separate manual, which is included in the box. You should familiarize yourself with the operation of the console before using this unit.

NOTE: Depending on your preference, the top center display of your console can be shown in miles per hour (MPH), kilometers per hour (KP/H) or revolutions per minute (RPM). To change your display, hold down the SELECT button for three seconds - make your selection using the + key - leave idle for 5 seconds.

Assembly Accessories

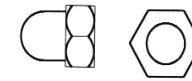

M8 Cap Nut (5)-4



8x19 Arc Washer (6)-8

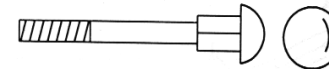

M8x70 Carriage Bolt (4)-2



M8x15 Screw(18)-4



6x13 Washer (64)-8



M6x40 Hex Head Screw (66)-8

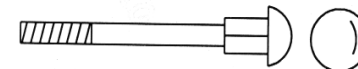

M8x85 Carriage Bolt (9)-2

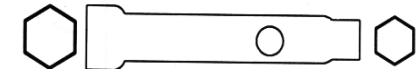

Hexa-tube Wrench

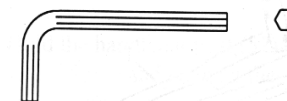

Allen Wrench

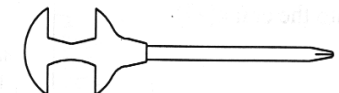

Screw Driver



Iron Plate (21)-1



4x8 Screw(19)-4

Assembly of CardioMax Exercise Bike

1. Attach front and rear stabilizer (2, 7) to the main frame (1) with the carriage bolts, arc washers and nuts.

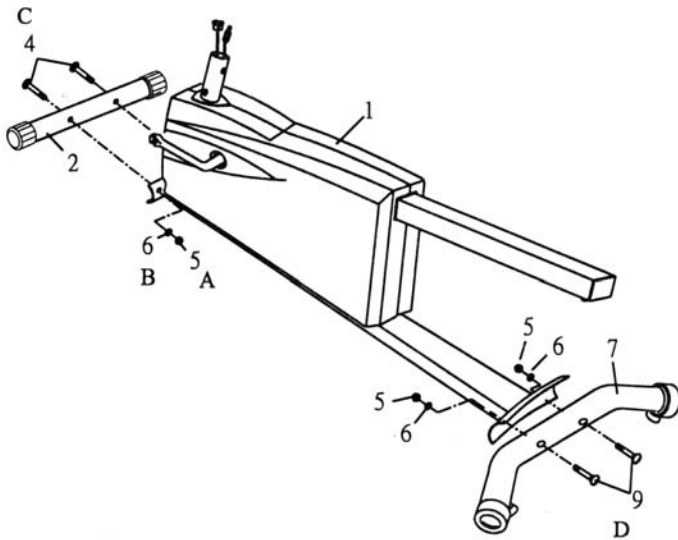

2. Tighten the pedals (46, 48) into the crank (43). Axles of pedals are branded "L" and "R." The pedal marked "R" goes on the right hand side of the bike and the one marked "L" on the left hand side. Tighten the left pedal by turning counter clockwise and the right pedal by turning clockwise.

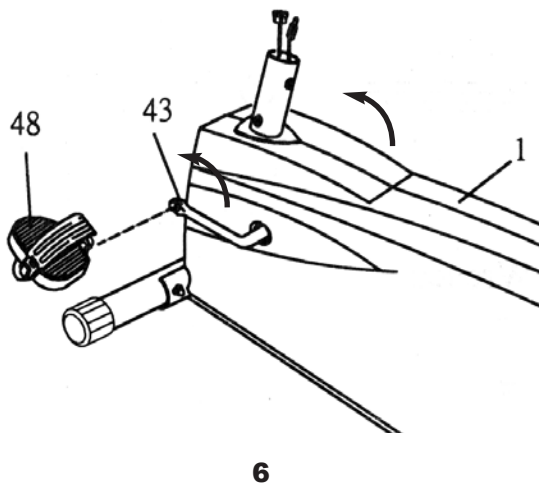

6

3. Slide the seat carriage (60) onto the frame, making sure not to pinch any of the wires. Connect heart rate wires from the seat carriage to those in the main frame then slide excess wiring up into frame. Cover opening with iron plate (21) and screws (19). Screw the adjustment knob (49) into the side of the carriage. Attach the slide stop (screw 28, nut 45) into the end of frame post.

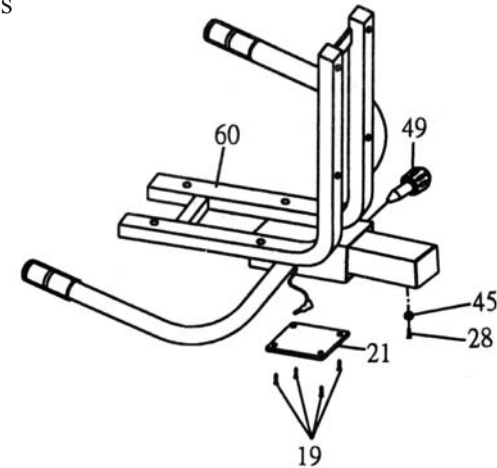

4. Attach seat and seat back onto seat carriage with screws (66) and washers (64).

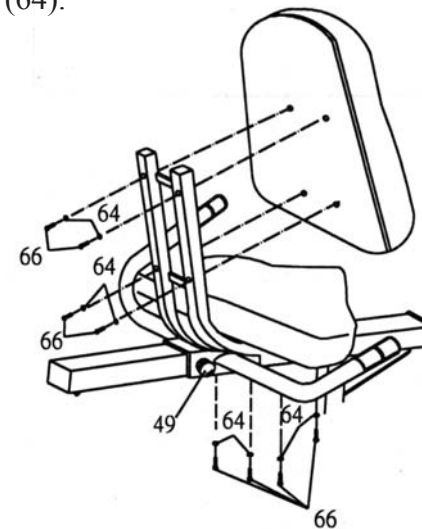

7

5. Connect the pulse and sensor wires from the main frame to those in the handlebar post (57). Insert the post into the frame and secure with screws (18) and washers (6).

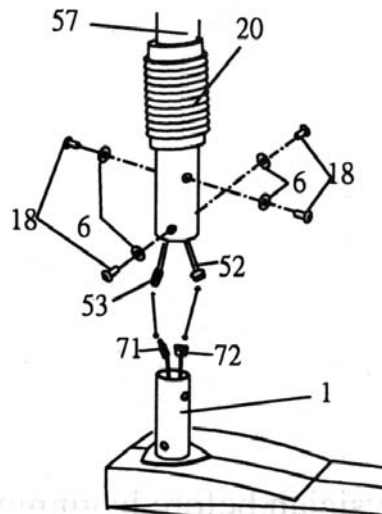

6. Insert batteries into console compartment. Connect the sensor wire and pulse wire from the post to the back of the console (58). Attach the console to the post with screws and washers. (The screws and washers are provided with the console.)

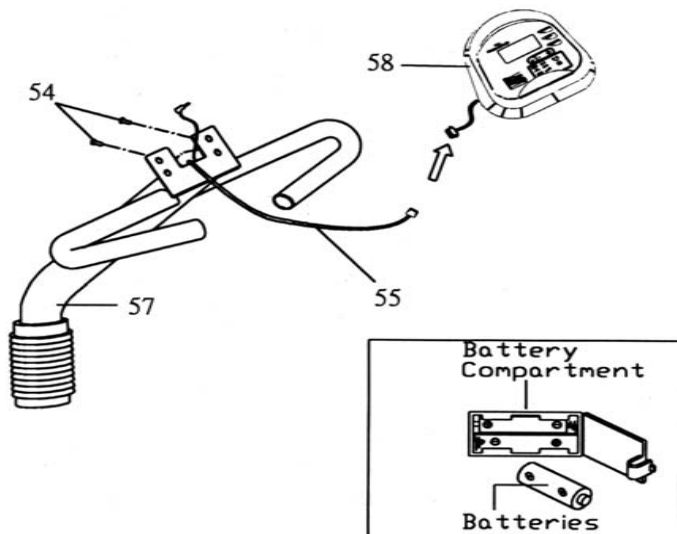

8

580 Recumbent Exploded View

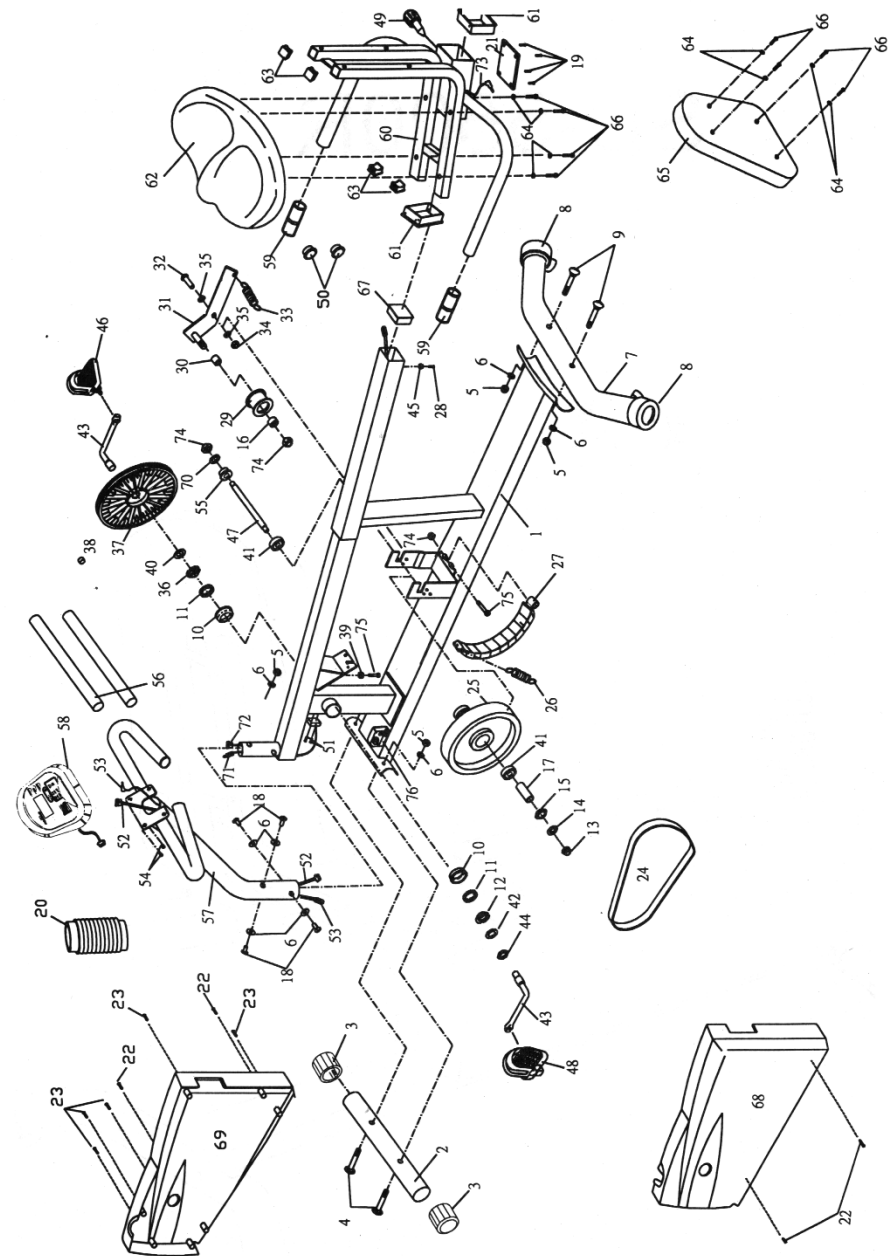

9

580 Recumbent Parts List

NO	PART NAME	QTY	NO	PART NAME	QTY
1	MAIN FRAME	1	40	WASHER	1
2	FRONT STABILIZER60*500	1	41	BEARING 6004	2
3	WHEEL CAP	2	42	SNAP WASHER	1
4	CARRIAGE BOLT M8*70	2	43	CRANK	2
5	NUT CAP M8	4	44	HEX SCREW	1
6	ARC WASHER8*19*1.5	8	45	NUT 3/16"	1
7	REAR STABILIZER 75	1	46	RIGHT PEDAL	1
8	END CAP 75	2	47	WHEEL AXLE	1
9	CARRIAGE BOLT M8*85	2	48	LEFT PEDAL	1
10	BEARING HOUSING	2	49	ADJUSTABLE KNOB	1
11	BALL BEARING	2	50	HANDLEBAR CAP	2
12	INSIDE BEARING COLLAR	1	51	ROUND HEAD SCREW M3*8	2
13	NUT	1	52	CABLE WIRE	1
14	WASHER10*19*1.5	1	53	UPPER PULSE WIRE	1
15	BC NUT 3/8"	1	54	SCREW	2
16	BEARING6000ZZ	1	55	GREASED BEARING	1
17	WHEEL CAP	1	56	HANDLEBAR FOAM	2
18	HEX HEAD BOLT M8*15	4	57	UPRIGHT POST	1
19	SCREW M4*8	4	58	CONSOLE	1
20	UPRIGHT CAP	1	59	HANDLEBAR SPACER	2
21	IRON PLATE	1	60	SEAT FRAME	1
22	SCREW	4	61	BUSHING	2
23	ROUND HEAD SCREW	5	62	SEAT	1
24	BELT	1	63	SEAT FRAME CAP	4
25	WHEEL	1	64	WASHER 6*13*1	8
26	SPRING	1	65	BACKREST	1
27	MAGNETIC PLATE	1	66	HEX HEAD BOLT M6*40	8
28	SCREW 3/16"*5/8"	1	67	BUSHING	1
29	IDLER WHEEL	1	68	LEFT COVER	1
30	IDLER WHEEL SPACER	1	69	RIGHT COVER	1
31	IDLER ARM	1	70	WASHER 8*19*1.5	1
32	HEX SCREW3/8"*30	1	71	SENSORWIRE	1
33	SPRING	1	72	CABLE WIRE	1
34	NYLOCK NUT 3/8"	1	73	PULSE WIRE	1
35	WASHER10*26*2	1	74	NYLOCK NUT M8	2
36	OUTSIDE BEARING COLLAR	1	75	SCREW M8*60	7
37	PULLEY	1	76	MOTOR	1
38	MAGNETIC	1			
39	NUT M8	1			

Monitoring Your Heart Rate

To obtain the greatest cardiovascular benefits from your exercise workout, it is important to work within your target heart rate zone. The American Heart Association (AHA) defines this target as 60%-75% percent of your maximum heart rate.

Your maximum heart rate may be roughly calculated by subtracting your age from 220. Your maximum heart rate and aerobic capacity naturally decreases as you age. This may vary from one person to another, but use this number to find your approximate effective target zone. For example, the maximum heart rate for an average 40 year-old is 180 bpm. The target heart rate zone is 60%-75% of 180 or 108-135 bpm. See *Fitness Safety* on page 12.

Before beginning your workout, check your normal resting heart rate. Place your fingers lightly against your neck, or against your wrist over the main artery. After finding your pulse, count the number of beats in 10 seconds. Multiply the number of beats by six to determine your pulse rate per minute. We recommend taking your heart rate at these times; at rest, after warming up, during your workout and two minutes into your cool down, to accurately track your progress as it relates to better fitness.

During your first several months of exercising, the AHA recommends aiming for the lower part of the target heart rate zone- 60%, then gradually progressing up to 75%.

According to the AHA, exercising above 75% of your maximum heart rate may be too strenuous unless you are in top physical condition. Exercising below 60% of your maximum will result in minimal cardiovascular conditioning.

Check your pulse recovery rate – If your pulse is over 100 bpm five minutes after you stop exercising, or if it's higher than normal the morning after exercising, your exertion may have been too strenuous for your current fitness level. Rest and reduce the intensity next time.

Fitness Safety

The target heart rate chart indicates average rate zones for different ages. A variety of different factors (including medication, emotional state, temperature and other conditions) can affect the target heart rate zone that is best for you. Your physician or health care professional can help you determine the exercise intensity that is appropriate for your age and condition.

(MHR) = Maximum Heart Rate

(THR) = Target Heart Rate

220 - age = maximum heart rate (MHR).

MHR x .60 = 60% of your maximum heart rate.

MHR x .75 = 75% of your maximum heart rate.

For example, if you are 30 years old, your calculations will be as follows:

$$220 - 30 = 190$$

$$190 \times .60 = 114 \text{ (low end or 60\% of MHR)}$$

$$190 \times .75 = 142 \text{ (high end or 75\% of MHR)}$$

For a 30 year-old the (THR) Target Heart Rate would be 114-142.

See Table on right for additional calculations.

Target Heart Rate Zone

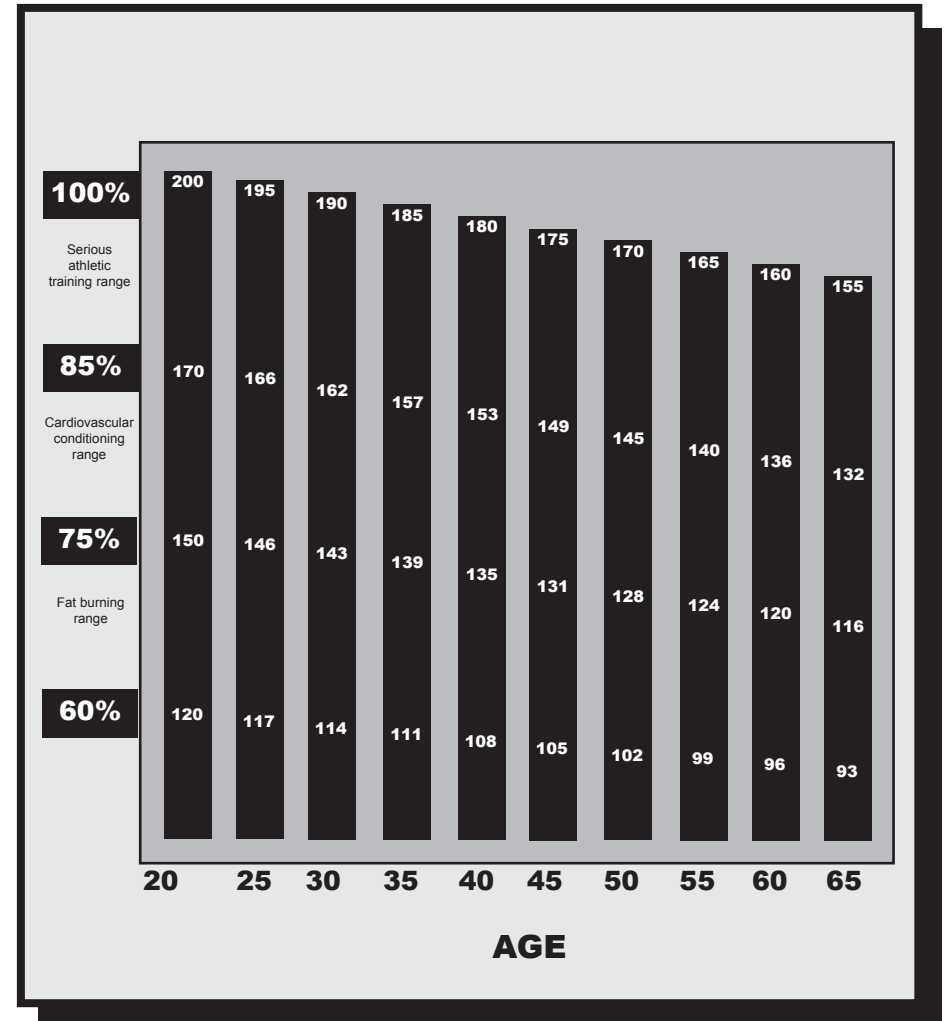

Free Manuals Download Website

<http://myh66.com>

<http://usermanuals.us>

<http://www.somanuals.com>

<http://www.4manuals.cc>

<http://www.manual-lib.com>

<http://www.404manual.com>

<http://www.luxmanual.com>

<http://aubethermostatmanual.com>

Golf course search by state

<http://golfingnear.com>

Email search by domain

<http://emailbydomain.com>

Auto manuals search

<http://auto.somanuals.com>

TV manuals search

<http://tv.somanuals.com>