

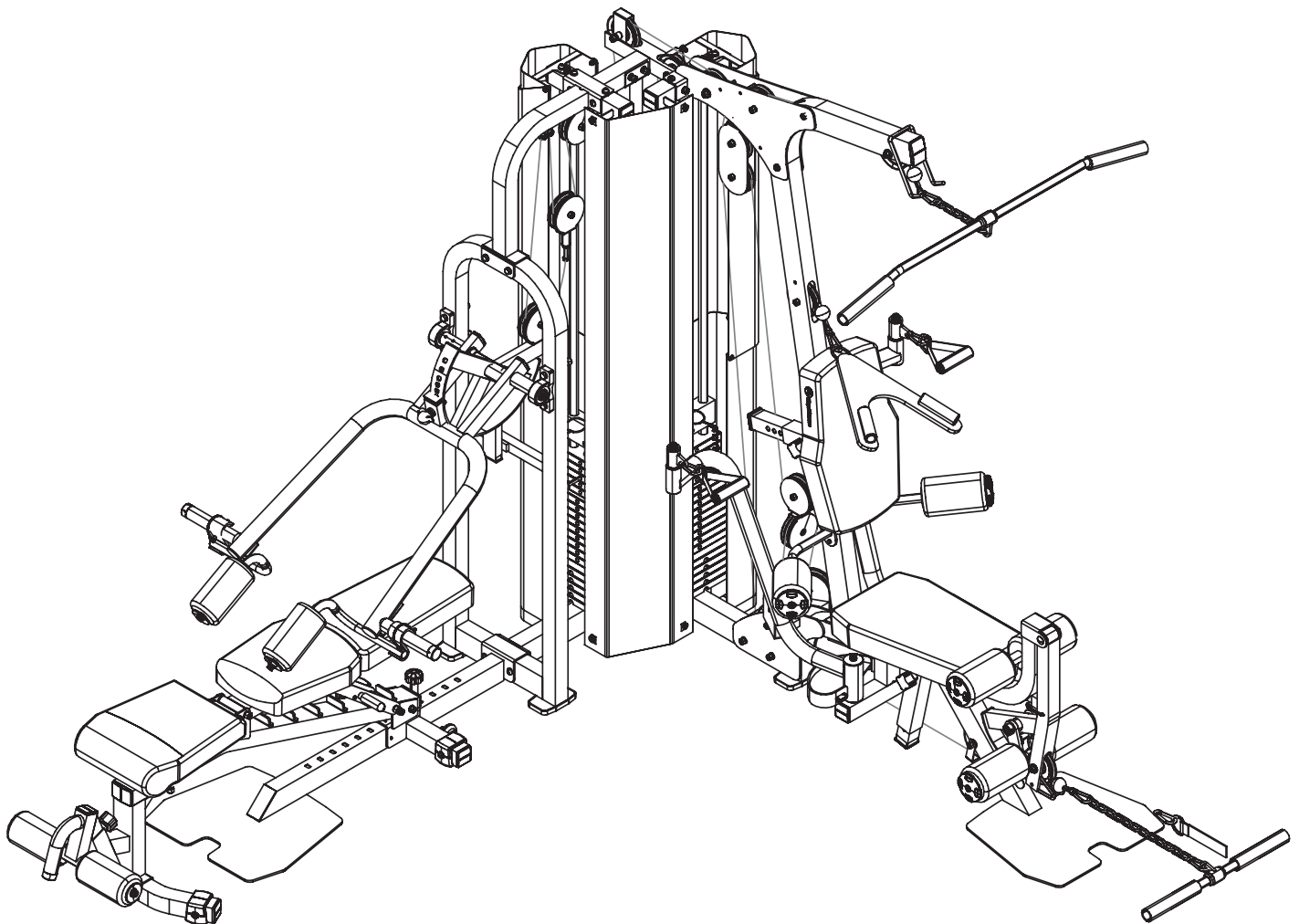

KeysFitness®

Owner's Manual

KF-2060



215-00132
11/06 Rev A



Before You Start	3
Important Safety Information	4
Assembly	5-40
Weight Ratios	41
Weight Stack Sticker Placement	42
Cable View	43
Top View	44
Exploded View	45
Parts List	46
Warranty Information	47

Before You Start



THANK YOU for making this unit a part of your exercise program. Keys Fitness assures the very best in value, appearance, durability and biomechanics.

This manual will guide you through the assembly process. If at any time you are having trouble with the assembly or use of this product, then please contact us at our Keys Fitness Helpline. We have trained service technicians on site to take care of you, our valued customer.

REGISTRATION CARD

To avoid unnecessary delays in warranty parts and to insure that a permanent record of your purchase is on file with our company, be sure to send in the warranty registration card or register on-line at www.keysfitness.com within 10 days of purchase.

KEYS FITNESS SERIES

QUESTIONS?

CALL

1-888-380-0482

Monday-Friday

8:30-5:30 Central Time

When calling please have the following product information available:

Model Name : KF-2060

Serial #:

Manufactured Date :

PO # :

Model Name Decal Location

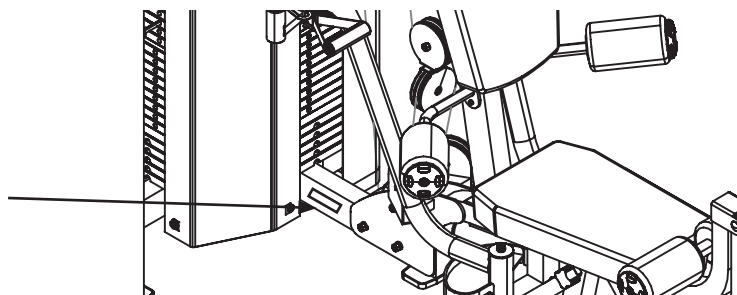

Prior to assembly, remove components from the box and verify that all the listed parts were supplied.

NOTE: Hand tighten bolts and nylon nuts until machine is fully assembled.

! CAUTION

Read all precautions and instructions in this manual before using this equipment.

WARNING!

Before using this unit or starting any exercise program, consult your physician. This is especially important for persons over the age of 35 and/or persons with pre-existing health problems. Keys Fitness Products LP assumes no responsibility for personal injury or property damage sustained by or through the use of this product.

It is the owner's responsibility to ensure that all users of this unit have read the Owner's Manual and are familiar with safety information and precautions.

SAFETY PRECAUTIONS

- This unit should only be used on a level surface and is intended for indoor use only. Keys Fitness recommends an equipment mat be placed under the unit to protect the floor or carpet and for easier cleaning.
- Wear comfortable, good-quality walking or running shoes and appropriate clothing. Do not use this unit with bare feet, sandals, socks or stockings!
- Always examine your unit before using to ensure all parts are in working order.
- Do not leave children unsupervised near or on the unit.
- Service to your unit should only be performed by an authorized service representative, unless authorized and/or instructed by a Keys Fitness technician. Failure to follow these instructions will void the warranty.

Box 1



【 3 】 1pc

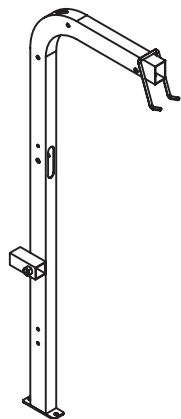

【 7 】 1pc

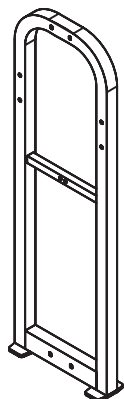

【 10 】 1pc



【 47 】 4pcs



【 55 】 2pcs



【 20 】 1pc

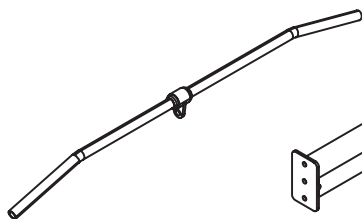

【 43 】 1pc

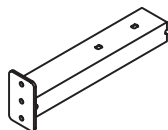

【 4 】 1pc

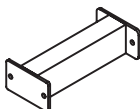

【 8 】 1pc

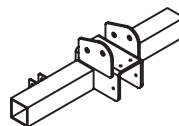

【 15 】 1pc

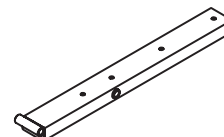

【 17 】 1pc

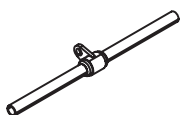

【 44 】 1pc



【 57 】 19pcs



【 59 】 1pc

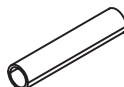

【 63 】 4pcs



【 76 】 1pc



【 104 】 2pcs



【 105 】 4pcs



【 78 】 2pcs



【 80 】 2pcs



【 92 】 1pc



【 93 】 1pc



【 100 】 1pc



【 120 】 2pcs



【 109 】 2pcs



【 79 】 2pcs



【 94 】 2pcs



【 153 】 2pcs



【 106 】 14pcs

Box 2

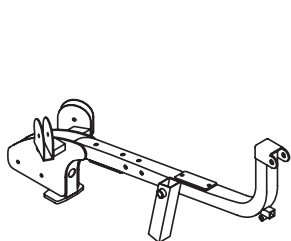

【6】 1pc

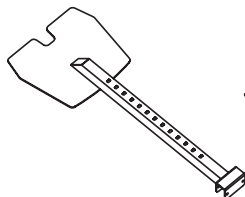

【11】 1pc

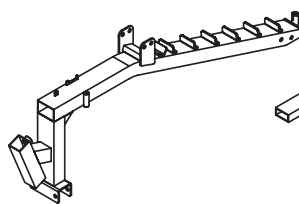

【13】 1pc

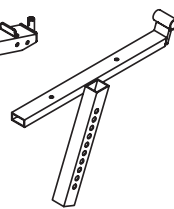

【27】 1pc

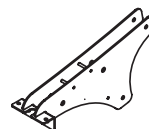

【5】 1pc

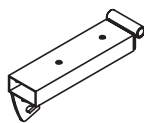

【16】 1pc



【18】 1pc

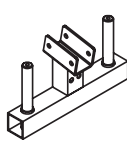

【21】 1pc



【39】 1pc



【24】 2pcs

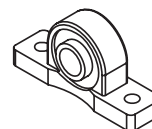

【75】 2pcs

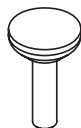

【45】 1pc



【59】 1pc



【21】 1pc

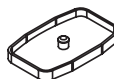

【80】 1pc



【76】 1pc



【68】 1pc



【82】 1pc



【71】 1pc

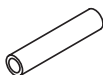

【70】 1pc



【69】 1pc



【72】 2pcs



【67】 2pcs



【92】 1pc



【93】 1pc



【94】 2pcs



【95】 3pcs



【96】 2pcs



【107】 1pc

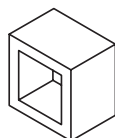

【81】 1pc



【104】 1pc



【105】 1pc



【83】 1pc

Box 3

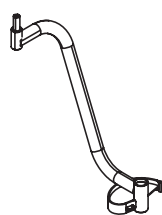

【22】 1pc

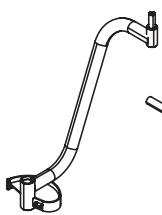

【23】 1pc

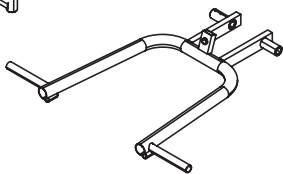

【35】 1pc

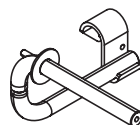

【37】 1pc

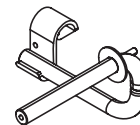

【36】 1pc

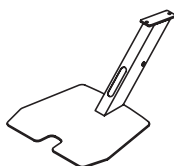

【19】 1pc



【30】 1pc

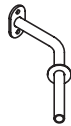

【29】 1pc



【40】 1pc



【38】 1pc

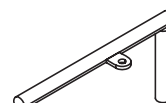

【64】 1pc



【116】 1pc



【56】 2pcs

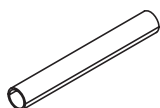

【72】 2pcs



【73】 1pc



【74】 1pc



【88】 1pcs



【87】 7pcs



【46】 2pcs



【66】 1pc



【124】 1pc



【86】 1pc



【85】 1pc



【121】 6pcs



【122】 2pcs



【123】 8pcs



【110】 1pc



【111】 1pc



【113】 1pc



【112】 1pc



【114】 1pc



【115】 1pc



【146】 1pc



【147】 1pc



【148】 1pc



【107】 2pcs



【99】 4pcs



【89】 6pcs



【90】 8pcs



【91】 2pcs



【96】 3pcs



【107】 2pcs



【102】 2pcs



【77】 4pcs



【161】 1pc



【162】 1pc



【163】 1pc

Box 4

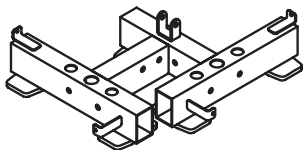

【1】 1pc

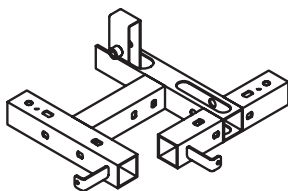

【2】 1pc

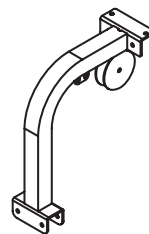

【9】 1pc

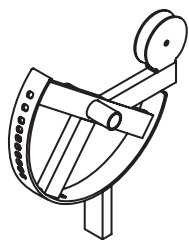

【12】 1pc

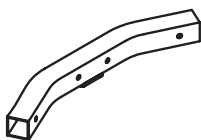

【14】 1pc

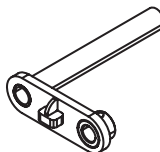

【25】 1pc

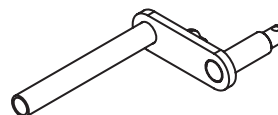

【26】 1pc

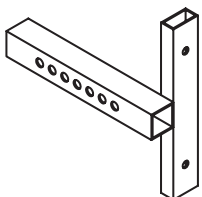

【28】 1pc



【32】 1pc

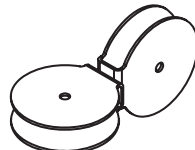

【31】 1pc



【33】 2pcs

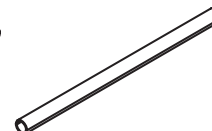

【34】 1pc

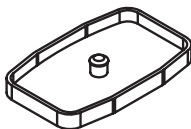

【80】 5pcs



【93】 5pcs



【95】 1pc



【96】 4pcs



【104】 2pcs



【108】 2pcs

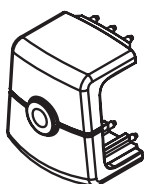

【79】 2pcs

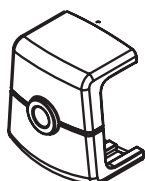

【153】 2pcs

Box 5

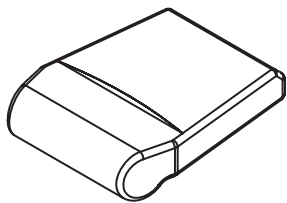

【48】 1pc

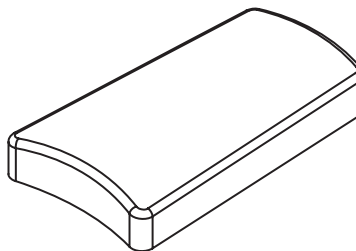

【49】 1pc

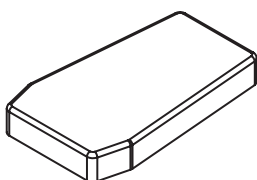

【50】 1pc



【51】 1pc

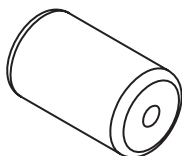

【58】 10pcs

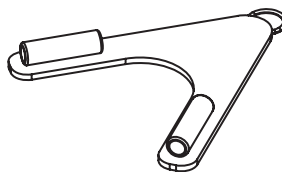

【60】 1pc

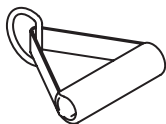

【61】 2pcs



【62】 1pc

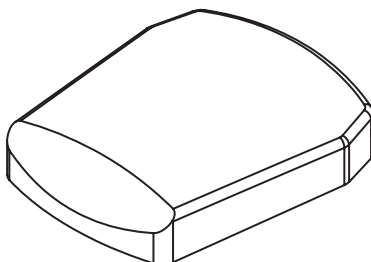

【156】 2pcs

Box 6

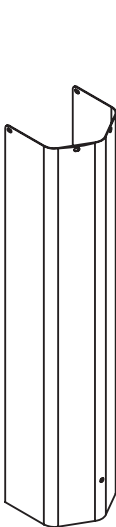

【41】 2pcs

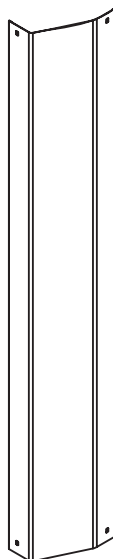

【42】 1pc

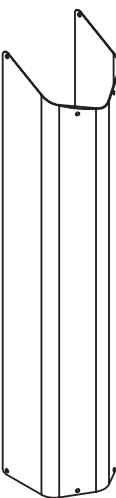

【157】 2pcs

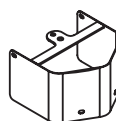

【145】 2pcs



【158】 16pcs

Box 7

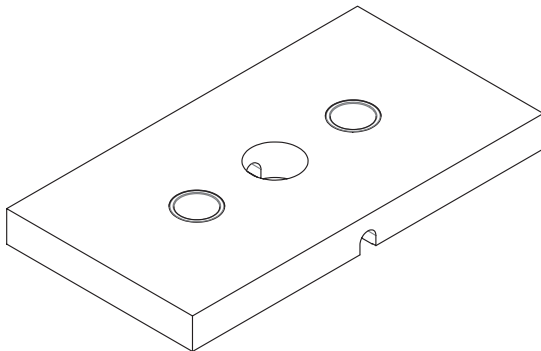

【52】 5pcs

Box 8

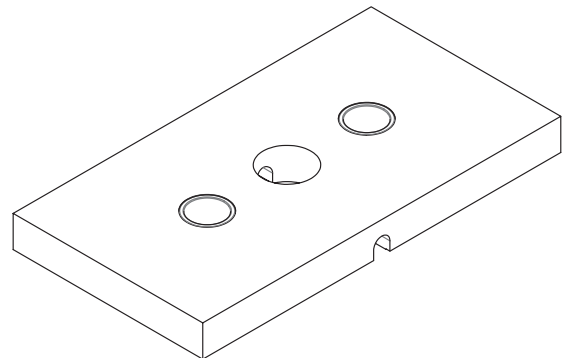

【52】 5pcs

Box 9

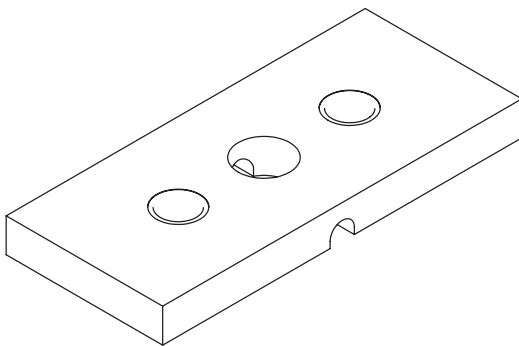

【53】 9pcs

Box 10

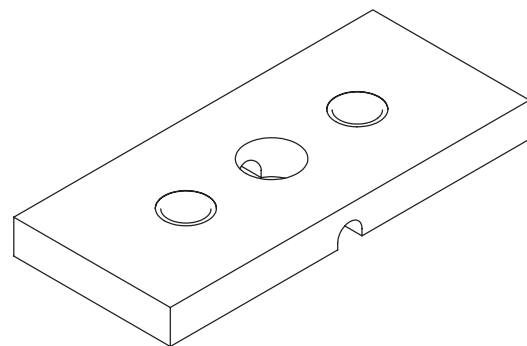

【53】 9pcs

Box 11

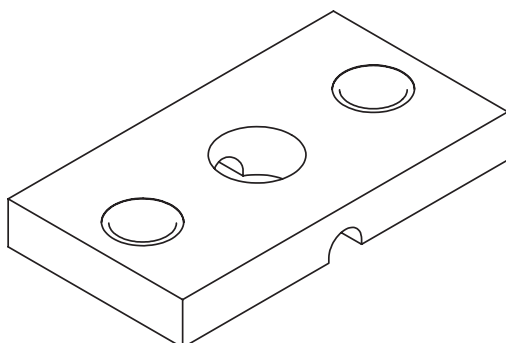

【54】 5pcs

Box 12

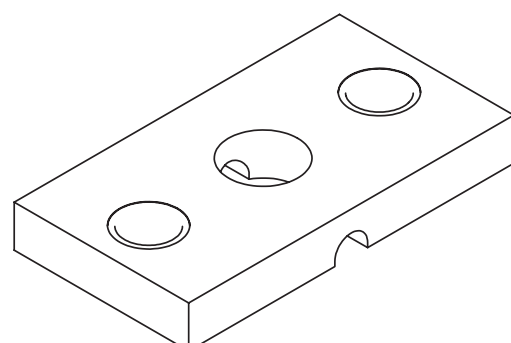

【54】 5pcs

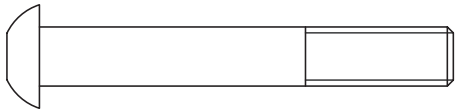

[137#] M10*70 11pcs

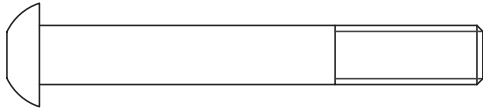

[136#] M10*75 12pcs

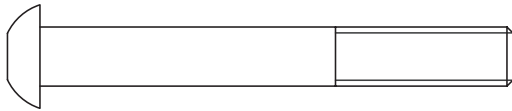

[135#] M10*80 7pcs

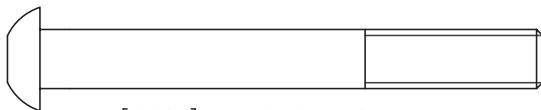

[134#] M10*85 6pcs

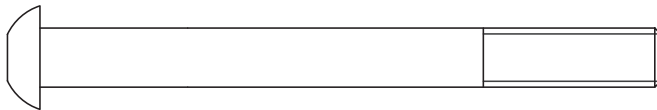

[133#] M10*105 2pcs

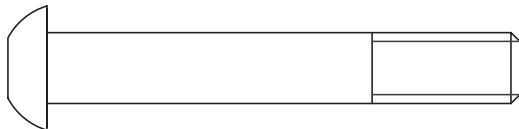

[131#] M12*80 4pcs

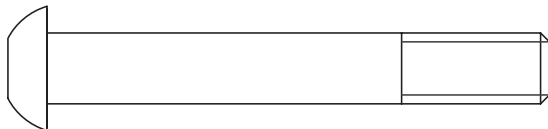

[130#] M12*85 4pcs

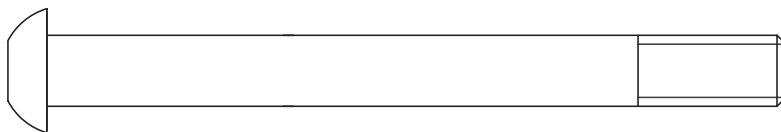

[132#] M12*125 4pcs

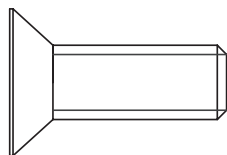

[150#] M12*35 2pcs

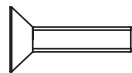

[103#] M4*20 2pcs

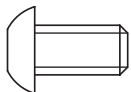

[98#] M8*15 9pcs



[97#] M8*6 3pcs

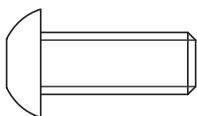

[128#] M10*25 12pcs



[140#] 10-32*3.2 6pcs

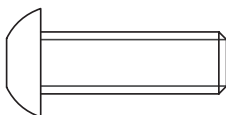

[142#] M10*30 4pcs



[159#] M6*18 16pcs

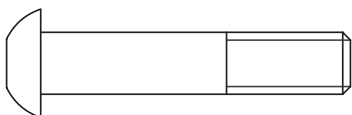

[127#] M10*50 4pcs



[160#] $\varnothing 6.6 * \varnothing 12 * 1.6$ 32

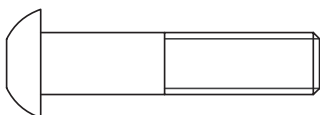

[141#] M10*45 12pcs



[118#] $\varnothing 8$ 1pc

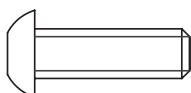

[154#] M8*25 8pcs

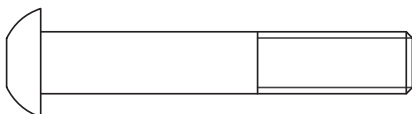

[139#] M10*60 1pc



[138#] M10*65 7pcs

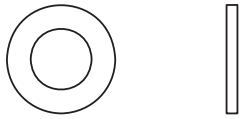

[155#] $\varnothing 9 * \varnothing 16 * 1.6$ 8pcs

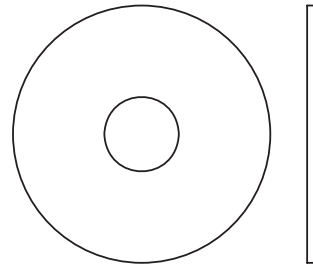

[101#] $\varnothing 38 * \varnothing 11 * 2$ 2pcs

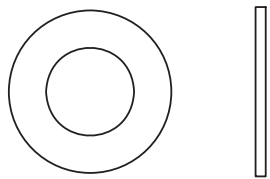

[125#] $\varnothing 24 * \varnothing 13 * 1.5$ 25pcs

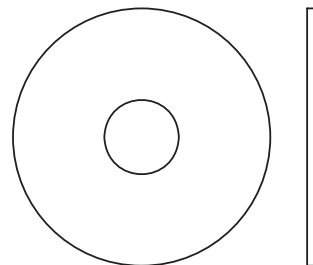

[129#] $\varnothing 38 * \varnothing 11 * 2$ 8pcs

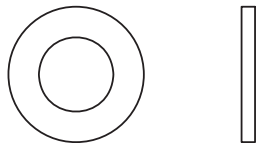

[143#] $\varnothing 20 * \varnothing 11 * 2$ 128pcs

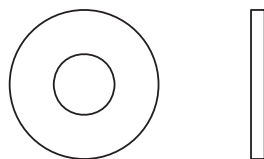

[117#] $\varnothing 22 * \varnothing 9 * 2$ 7pcs

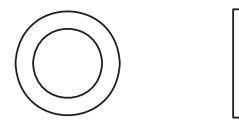

[119#] $\varnothing 10$ 17pcs

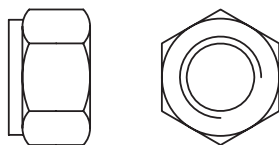

[126#] M12 13pcs

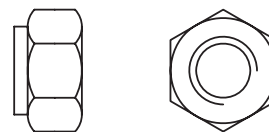

[144#] M10 52pcs

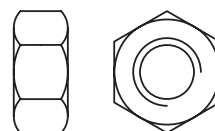

Step 1

Attach Right Base Frame (4) to Rear Frame (1) using two Nuts (144), four Washers (143), and two Bolts (137).

Attach Left Base Frame (8) to Rear Frame (1) using two Nuts (144), four Washers (143), and two Bolts (137).

Insert Guide Rods (47) into Rear Frame (1). Next, slide Weight Stack Bumpers (99) onto Guide Rods (47).

Attach Rear Upright (3) to Rear Frame (1) using two Nuts (144), four Washers (143), and two Bolts (136).

Figure 1

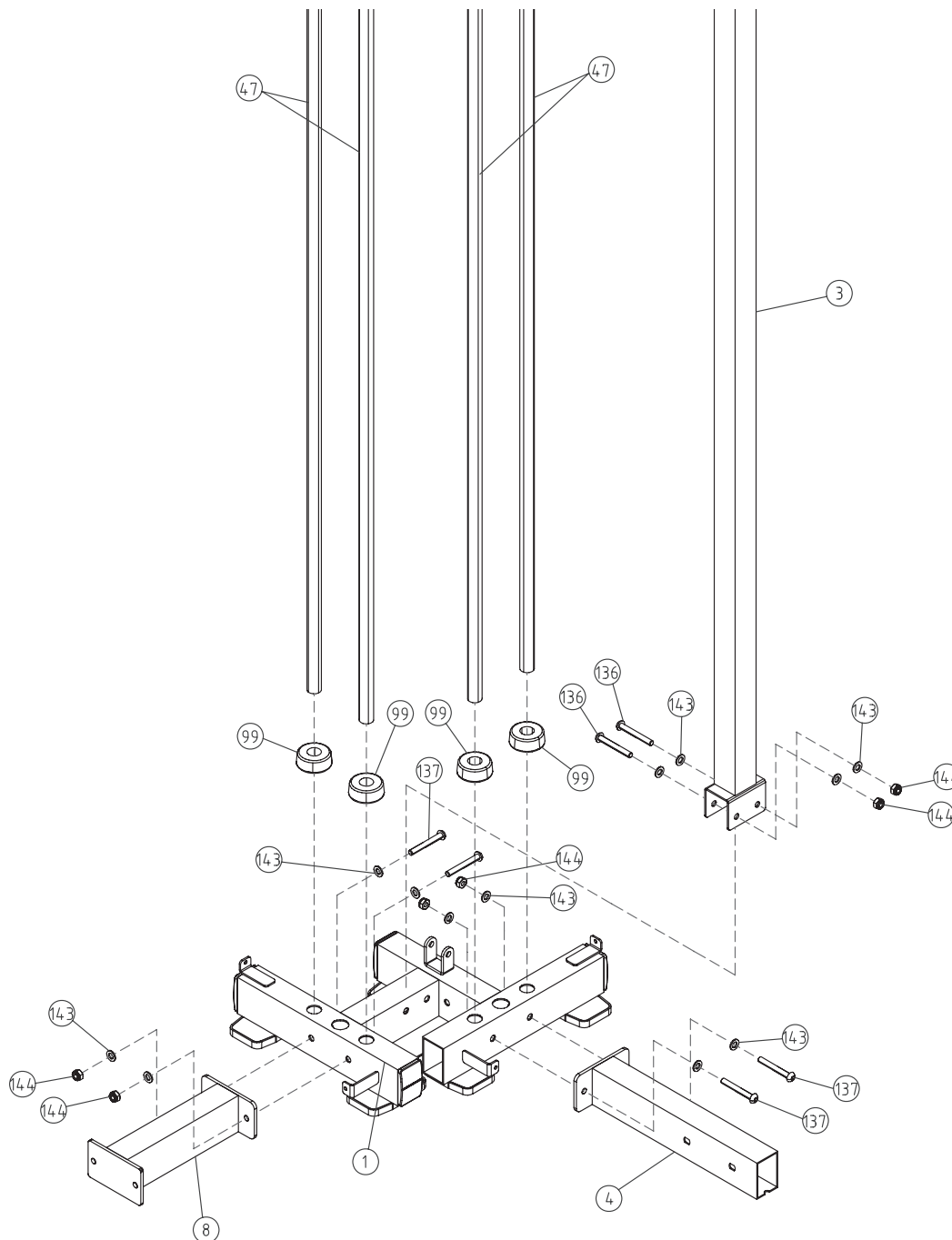

Step 2

Slide the weight plates down the Guide Rods (47) in this order - five 15lb Plates (52), nine 10lb Plates (53), five 5lb Plates (54), and the Top Plate (55). **Note:** Number of weight plates may vary depending on your specific configuration.

Attach Top Frame (2) to all four Guide Rods (47) and secure to Rear Upright (3) using two Nuts (144), four Washers (143), and two Bolts (136).

Figure 2

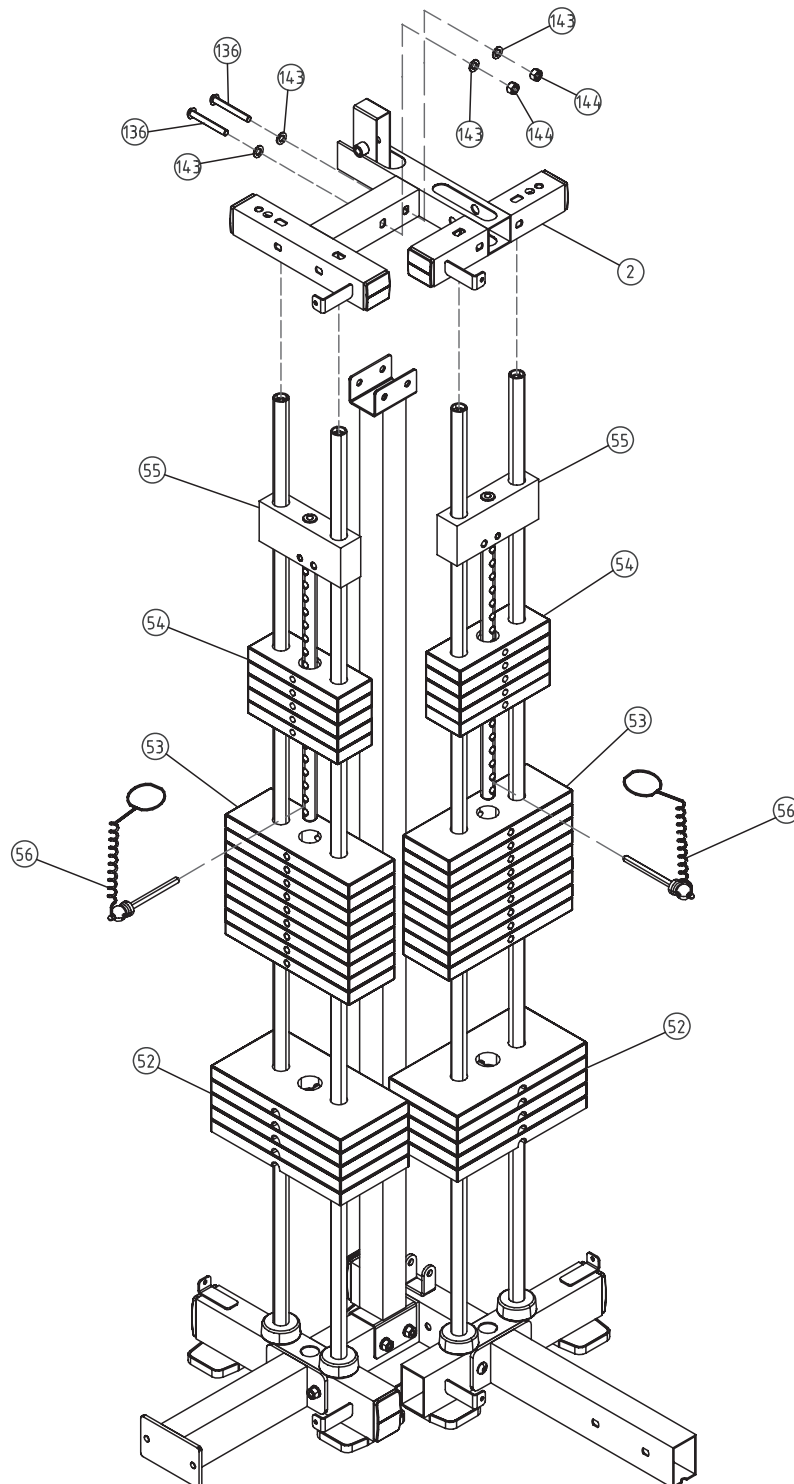

Step 3

Attach Front Upright (19) to Seat Pad Support Receptacle (6) using two Nuts (144), four Washers (143), and two Bolts (136).

Attach Seat Pad Support Receptacle (6) to Base Frame assembly using two Nuts (144), four Washers (143), and two Bolts (136).

Figure 3

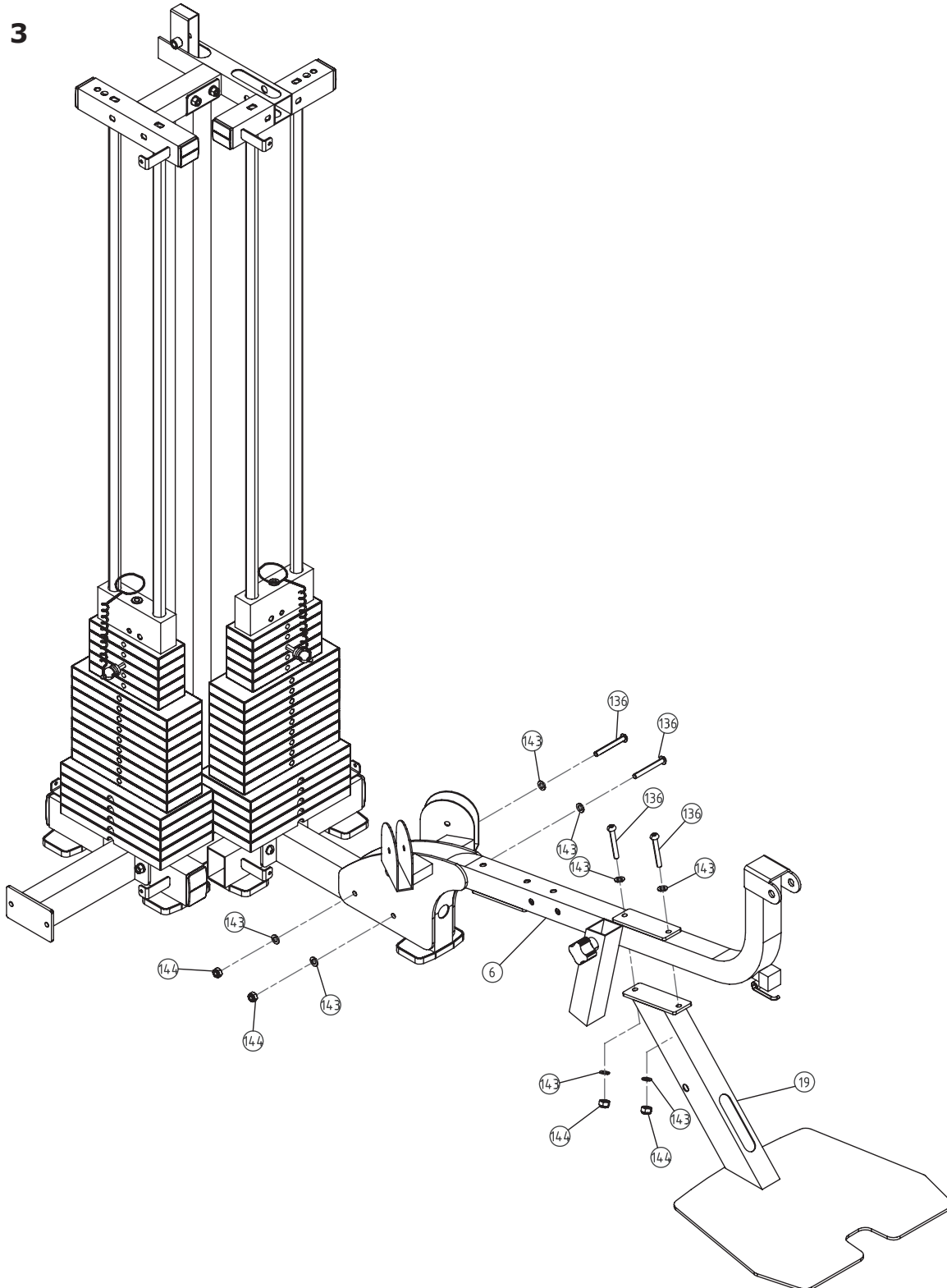

Step 4

Attach Main Upright (7) to Seat Pad Support Receptacle using two Nuts (126), four Washers (125), and two Bolts (131).

Attach Right Top Frame (5) to Top Frame assembly using two Nuts (144), four Washers (143), and two Bolts (137). Next, use two Washers (143), two Spring Washers (119), and two Bolts (142) to connect Right Top Frame (5) to Main Upright (7).

Figure 4

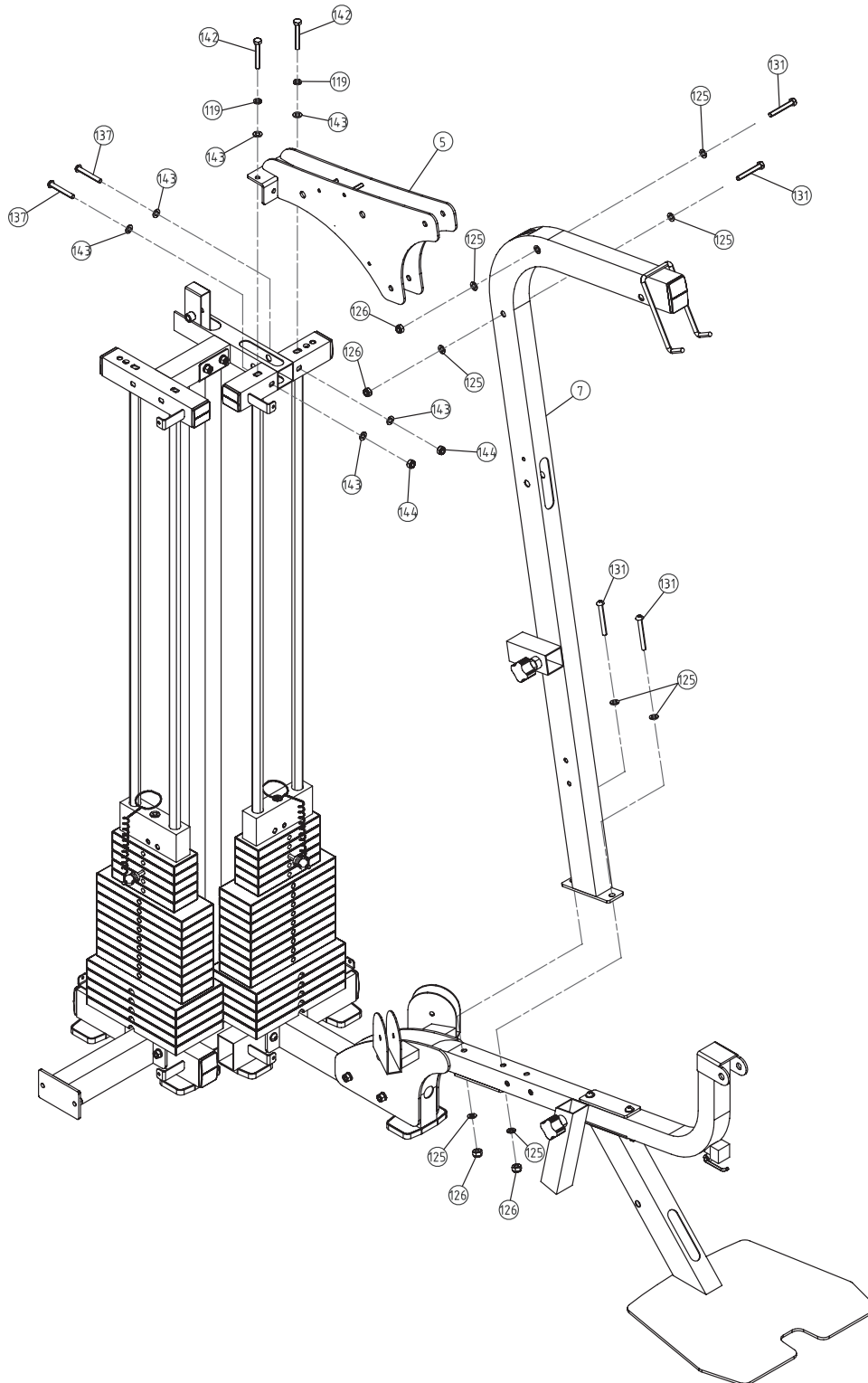

Step 5

Slide Press Station Base Frame (11) over Press Arm Support (10). Next, attach both pieces to Base Frame using two Nuts (144), four Washers (143), and two Bolts (134).

Install Left Top Frame over Press Arm Support (10) and Top Frame assembly. Secure top section using two Nuts (144), four Washers (143), and two Bolts (137). Next, Secure lower section using two Nuts (144), four Washers (143), and two Bolts (136). Secure top of Guide Rods (47) using two Washers (143), two Spring Washers (119), and two Bolts (142).

Figure 5

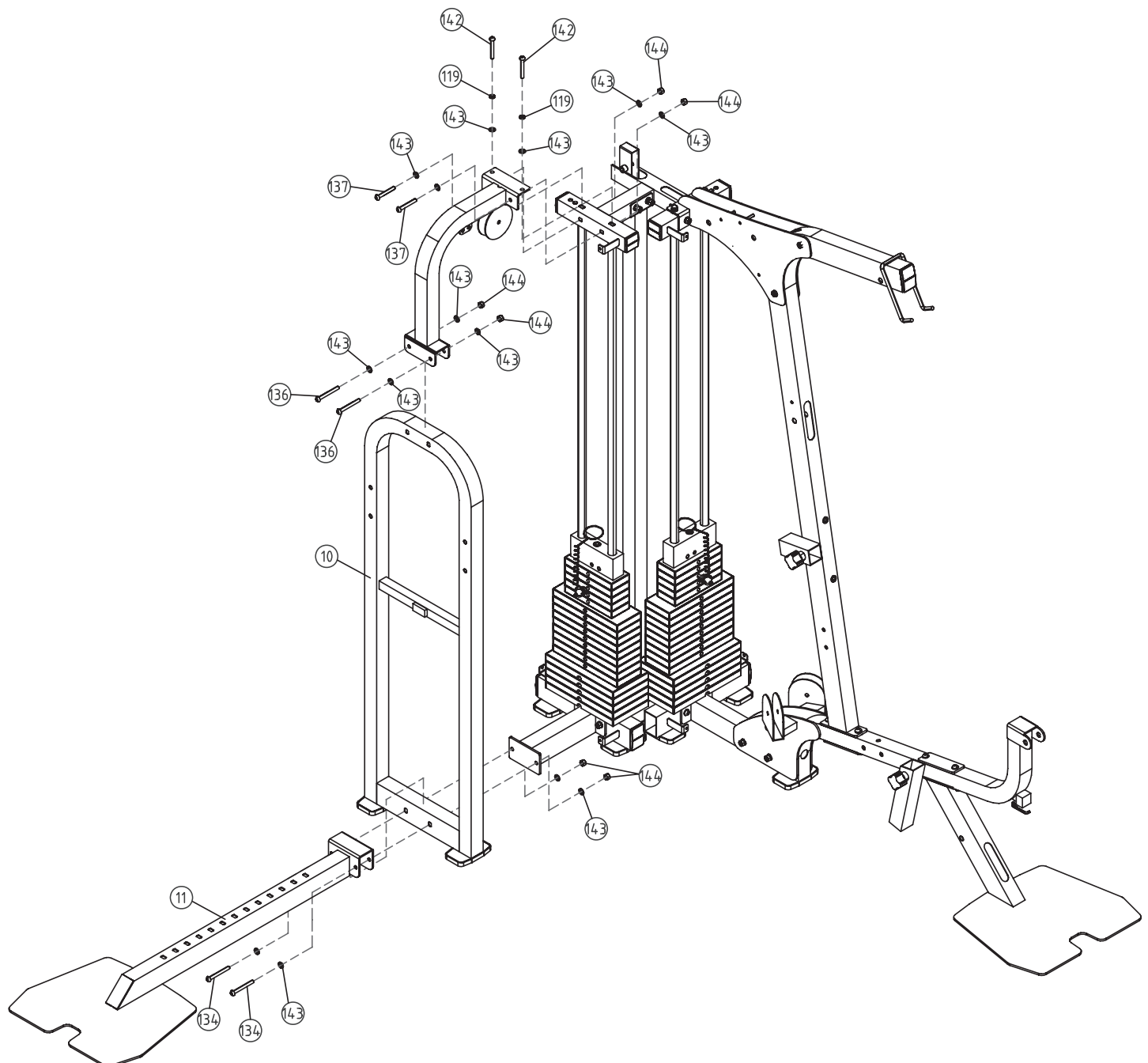

Step 6

Attach Pec Dec Mount (21) onto Seat Pad Support Receptacle using two Nuts (144), four Washers (143), and two Bolts (136). Secure in place with one Washer (129), one Spring Washer (119), and one Bolt (137).

Figure 6

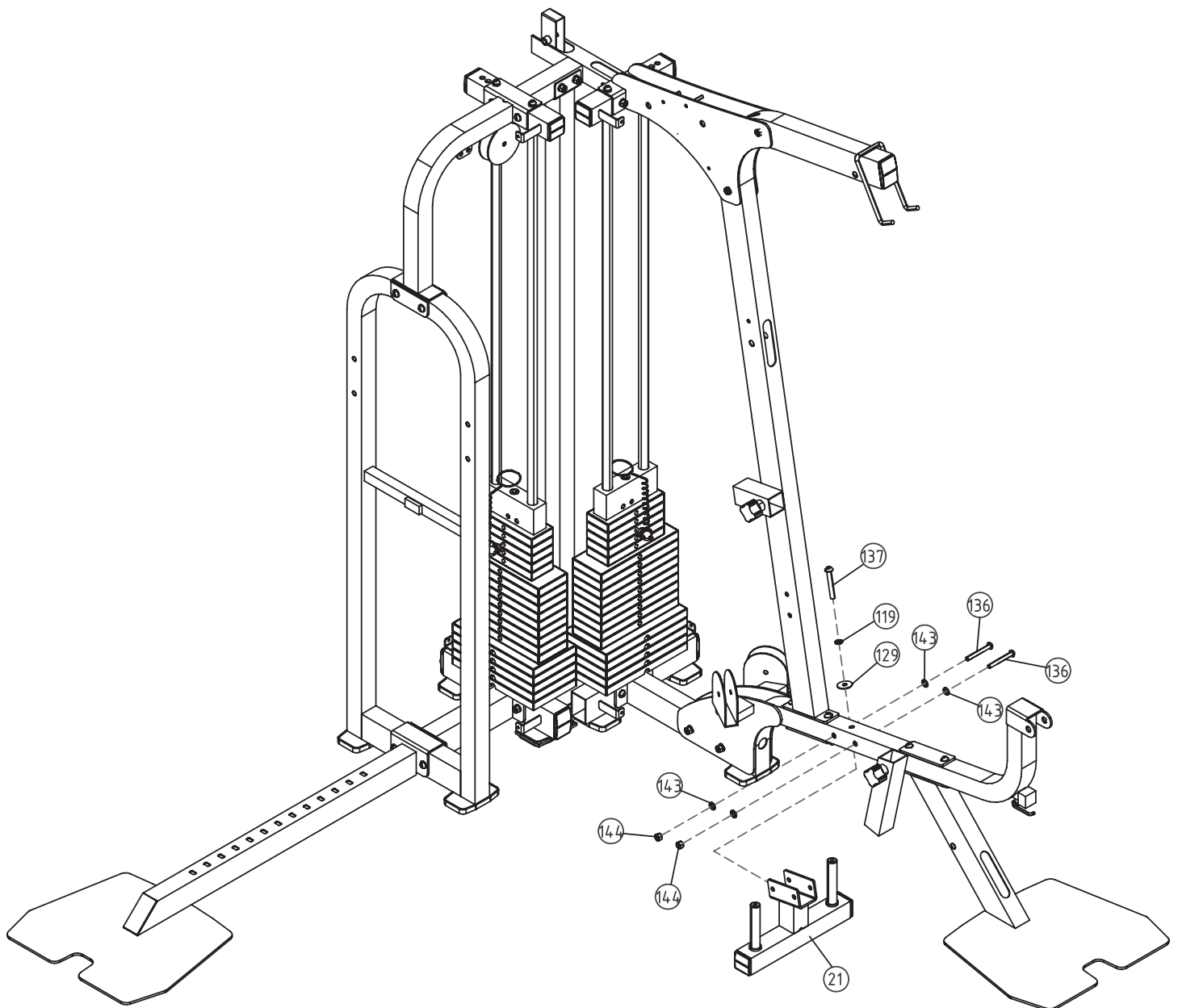

Step 7

Attach Right and Left Leg Hold Leg Frames (29 & 30) using two Nuts (144), four Washers (143), and two Bolts (135).

Figure 7

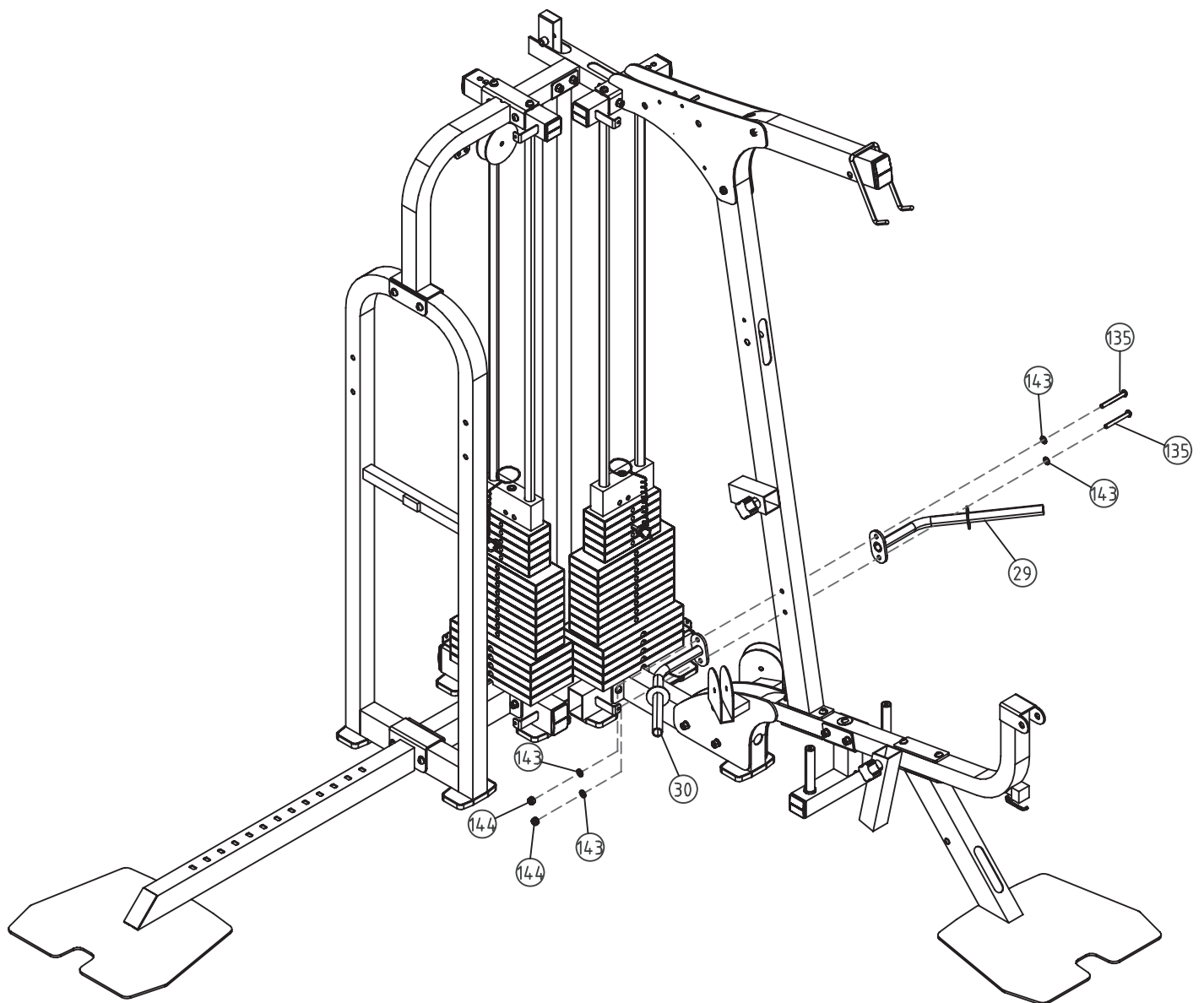

Step 8

Slide the Right Pec Dec Arm (22) on to the shaft of the Pec Dec Mount. Secure the arm in place using one Big Washer (102), one Washer (143), one Spring Washer (119), and one Bolt (128).

Slide Pec Dec Handle Bar (24) onto the top of the Right Pec Dec Arm (22) and secure using one Chrome Washer (101), one Washer (143), one Spring Washer (119), and one Bolt (128).

Repeat this step to complete the Left Pec Dec assembly.

Figure 8

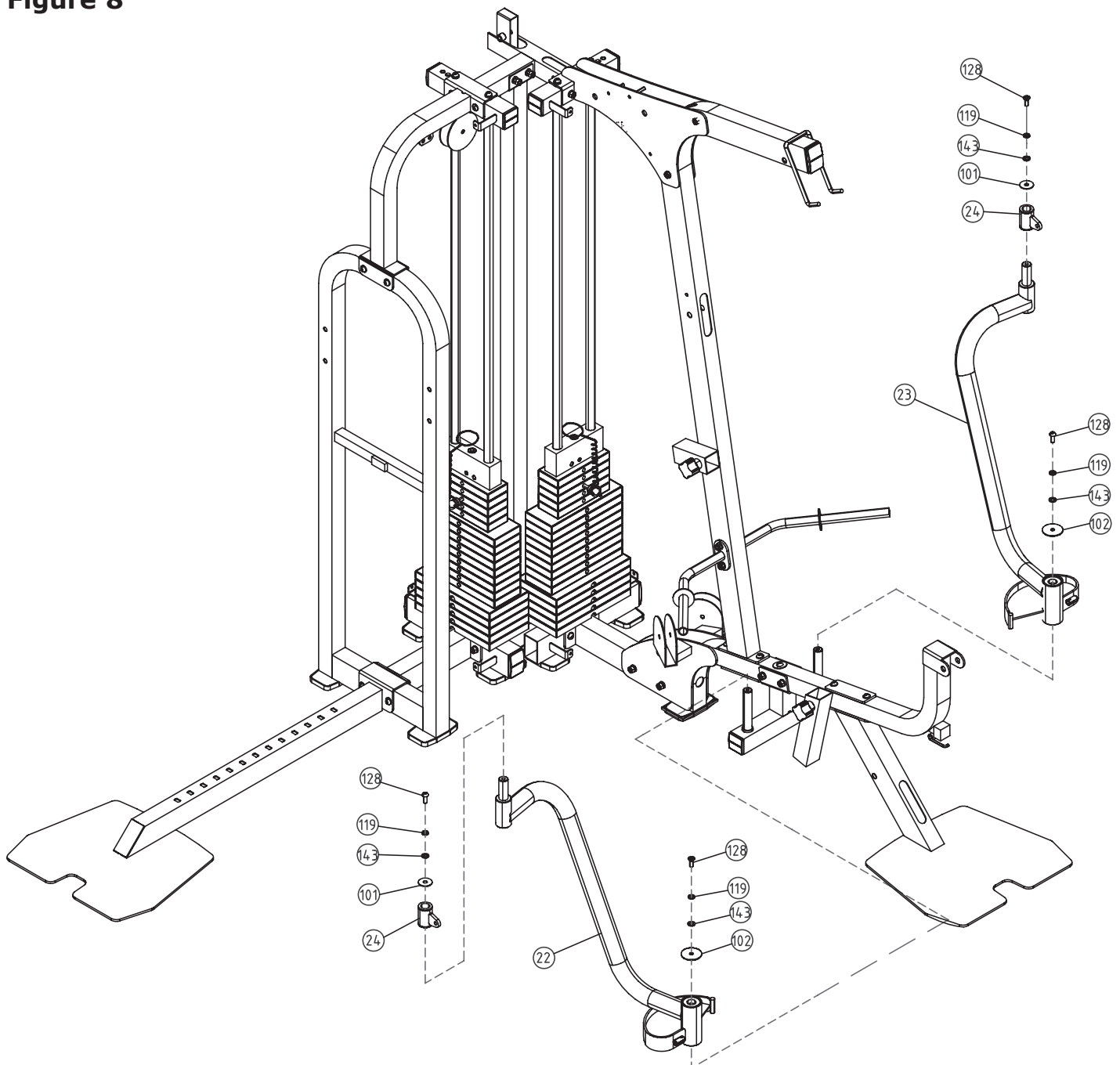

Step 9

Attach Leg Extension Lever (20) to Seat Pad Support Receptacle (6) and secure using Shaft (86), one Washer (117), one Spring Washer (118), and one Allen Bolt (98).

Slide Foam Frame w/ Shaft (26) through the Leg Extension Lever (20) and attach Foam Frame w/o Shaft (25) to the other side. Insert Slip Tension Pin (85) through the hole where the two foam frames meet.

Note: You may need to use a rubber mallet to install Slip Tension Pin (85).

Figure 9

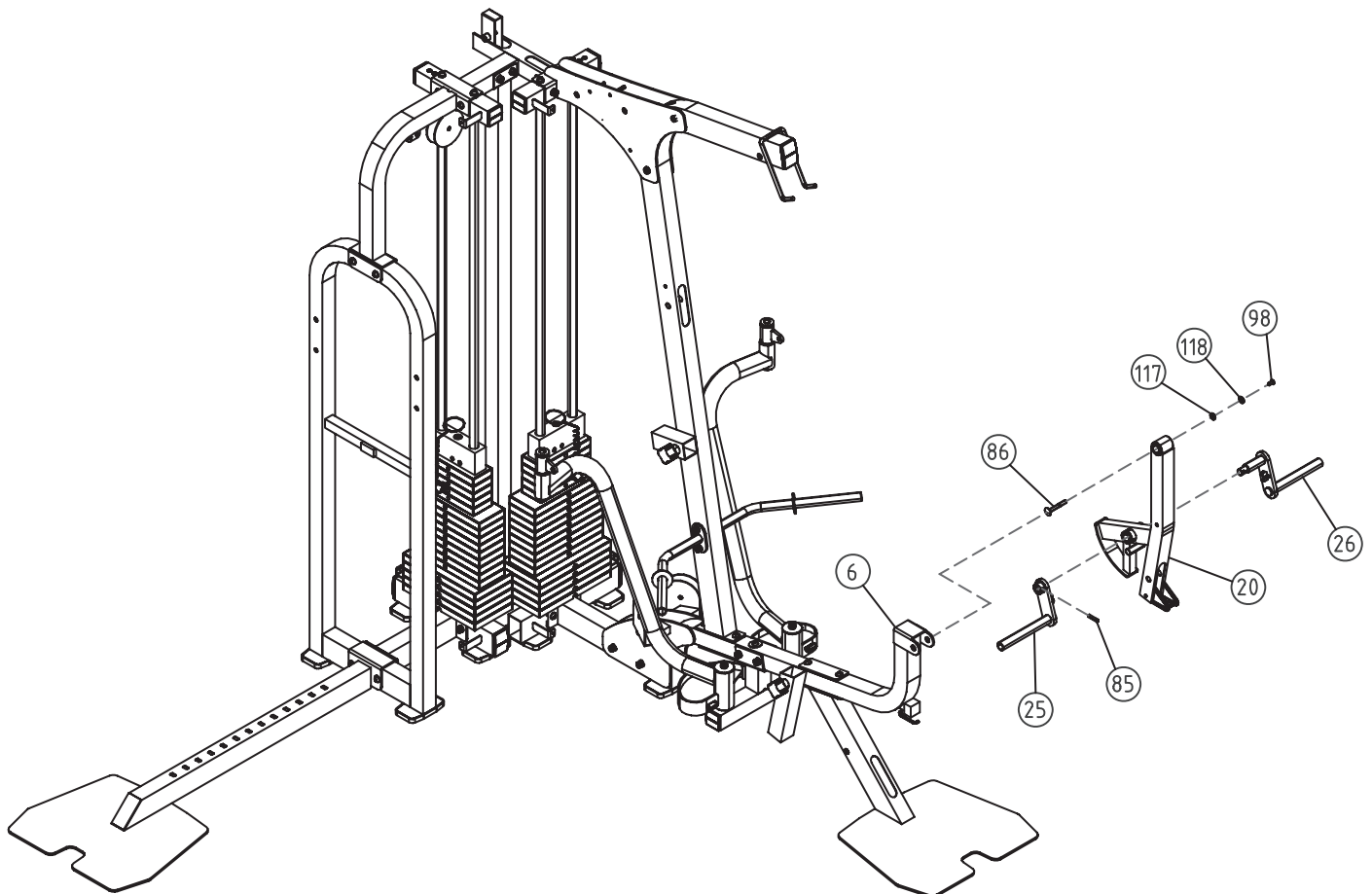

Step 10

Align Press Arm (35) and Chest Press Cam (12) while inserting Press Station Shaft (38). Slide Pillow Block Bearing (75) onto each side of Press Station Shaft (38) and secure the assembly using two Chrome Washers (101), two Washers (143), two Spring Washers (119), and two Allen Bolts (128).

Attach the entire assembly to Press Arm Support using four Nuts (126), eight Washers (125), and four Bolts (130).

Figure 10

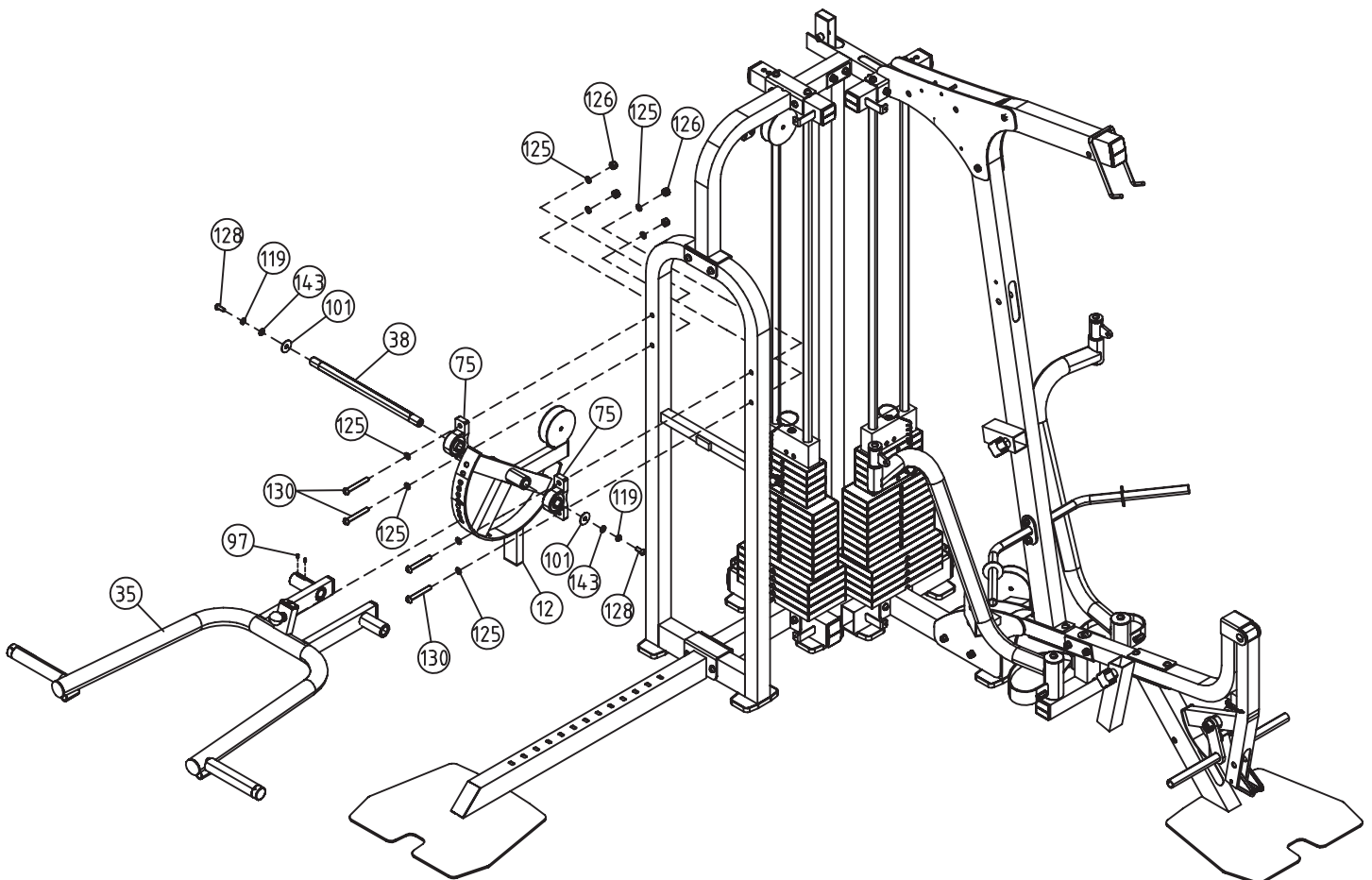

Step 11

Attach Bench Rear Frame (15) onto Bench Main Frame (13) and secure using two Nuts (144), four Washers (143), and two Bolts (133).

Attach Bench Front Stabilizer (14) on to Bench Main Frame (13) using two Nuts (144), four Washers (143), and two Bolts (136).

Figure 11

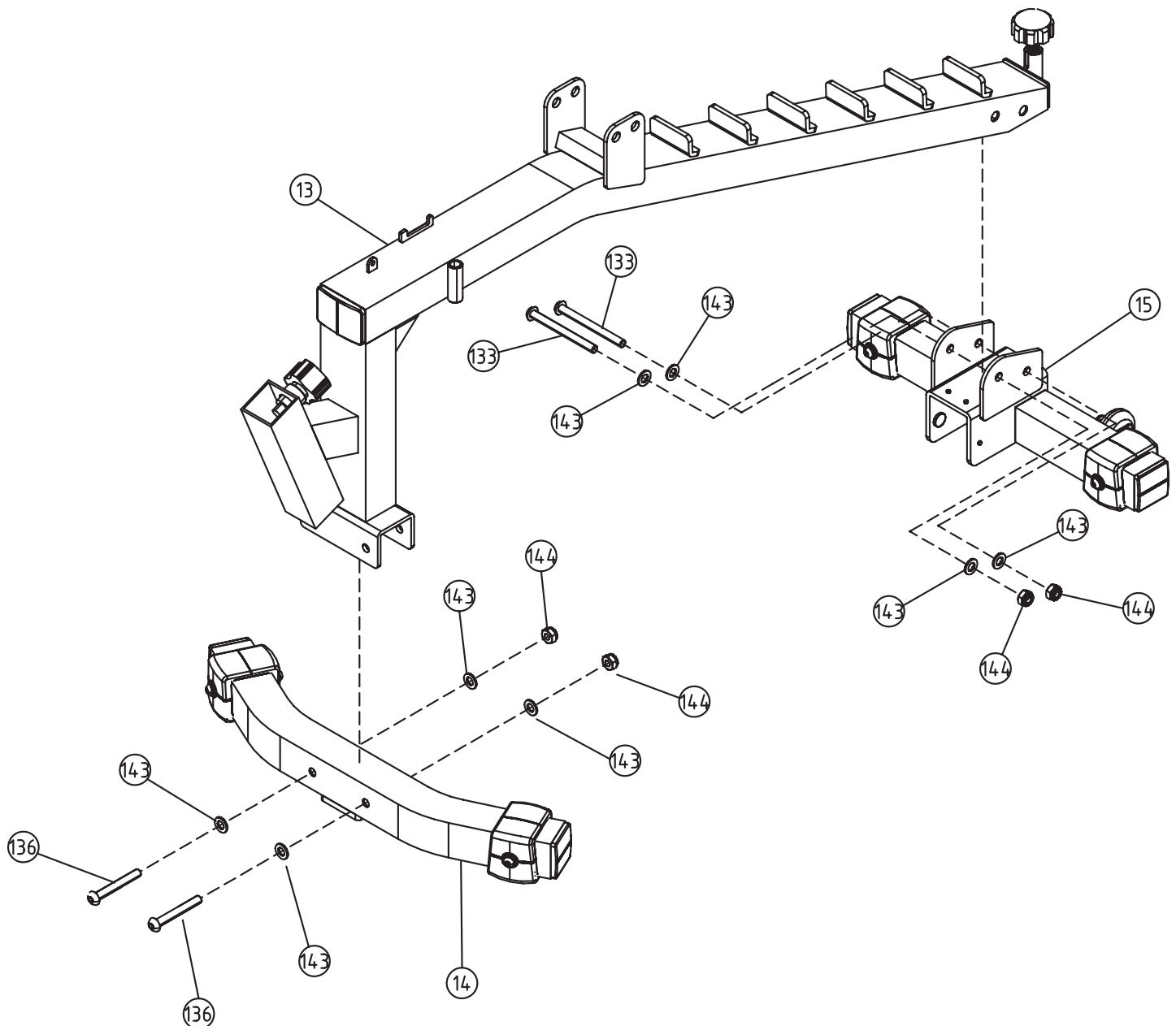

Step 12

Attach Bench Seat Pad Support (16) to Bench Main Frame using one Nut (126), two Washer (125), and one Bolt (132).

Insert Bench Seat Pad Adjustment Bar (64) into Bench Main Frame and secure using one Washer (125) and one Nut (126). Attach Spring (66) to Bench Main Frame and Bench Seat Pad Adjustment Bar (64).

Note: Make sure adjustment bar is installed into adjustable slots on Bench Seat Pad Support.

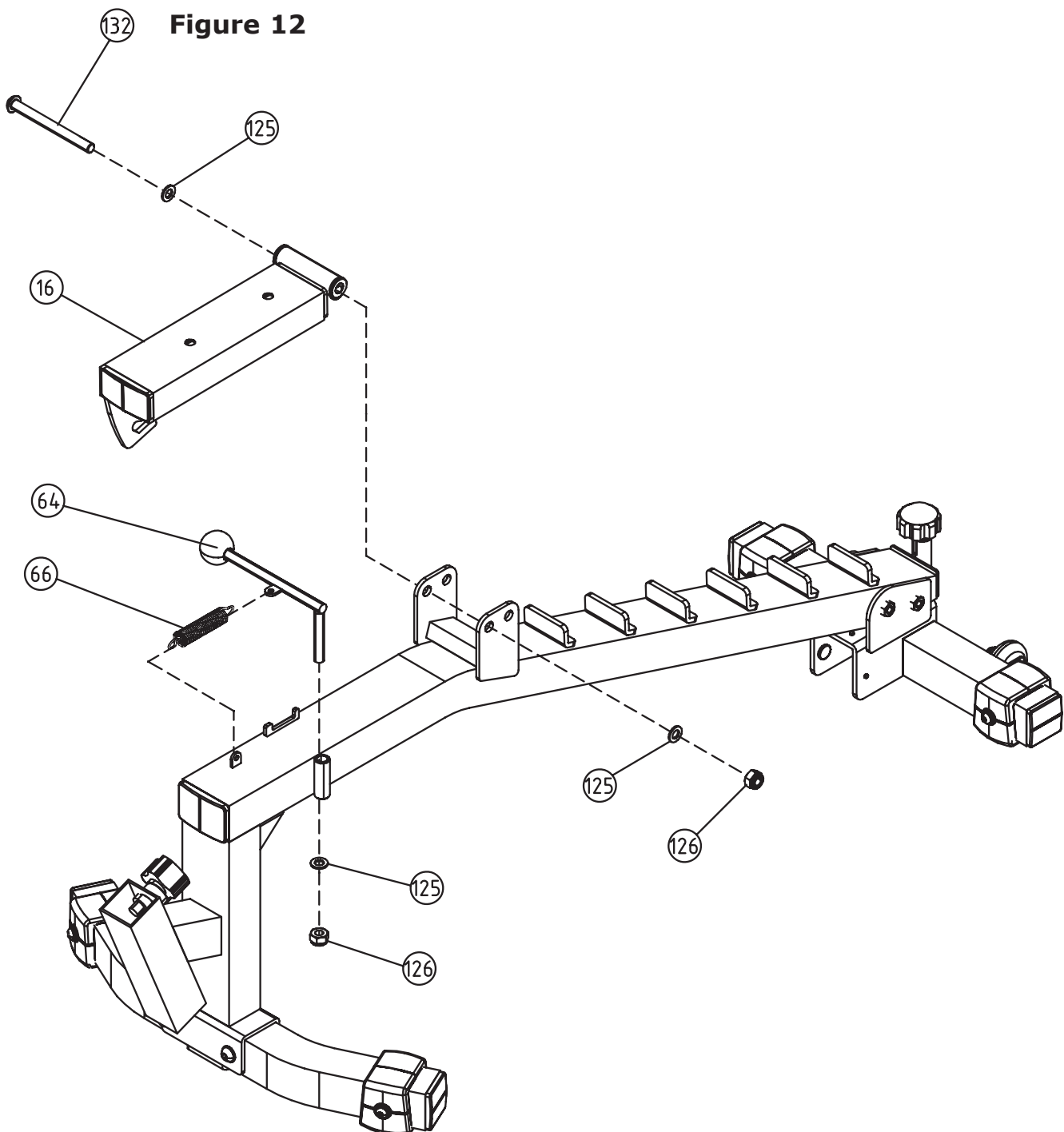

Step 13

Attach Bench Back Pad Support (17) to Bench Main Frame using one Nut (126), two Washers (125), and one Bolt (132).

Attach Bench Back Pad Adjustment Frame (39) to Bench Back Pad Support (17) using one Nut (126), two Washers (125), and one Bolt (132).

Figure 13

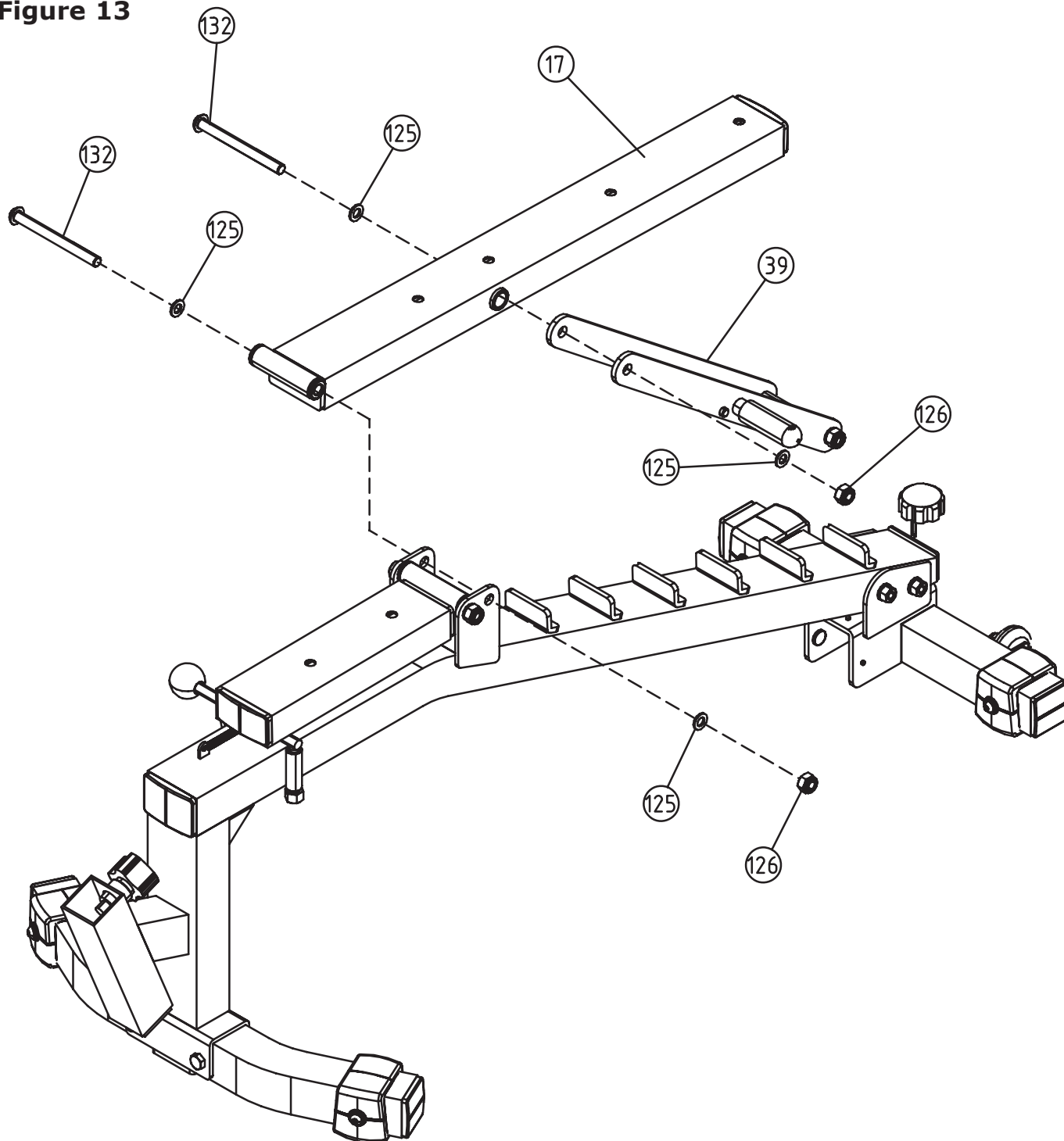

Step 14

Attach Bench Seat Pad (48), Bench Lower Back Pad (156) and Bench Back Pad (49) using six Washers (143) and six Bolts (138).

Insert Foam Shaft (40) into Foam Adjustable Bracket (18). Next, attach Upholstered Roller Pads (58) using the following hardware: four Plastic Washers (90), two Chrome Washers (101), two Washers (143), two Spring Washers (119), and two Bolts (128).

Figure 14

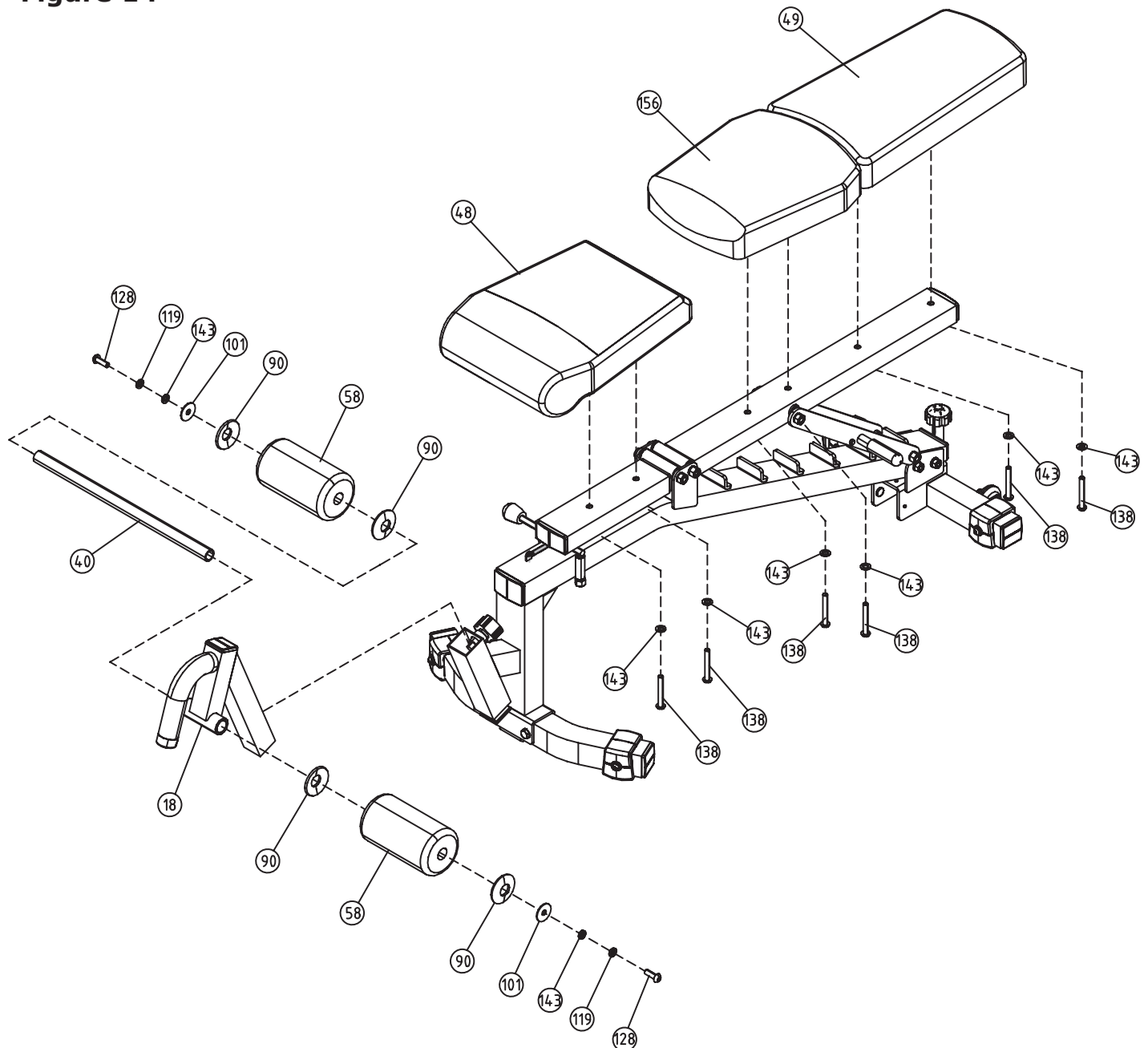

Step 15

Attach Left and Right Squat Arms (36 & 37) to the Press Arm Assembly (35) using two Safety Pins (73).

Next, slide Upholstered Roller Pad (58) onto each Squat Arm (36 & 37) and secure using two Plastic Washers (90), two Chrome Washers (101), two Washers (143), two Spring Washers (119), and two Bolts (128).

Figure 15

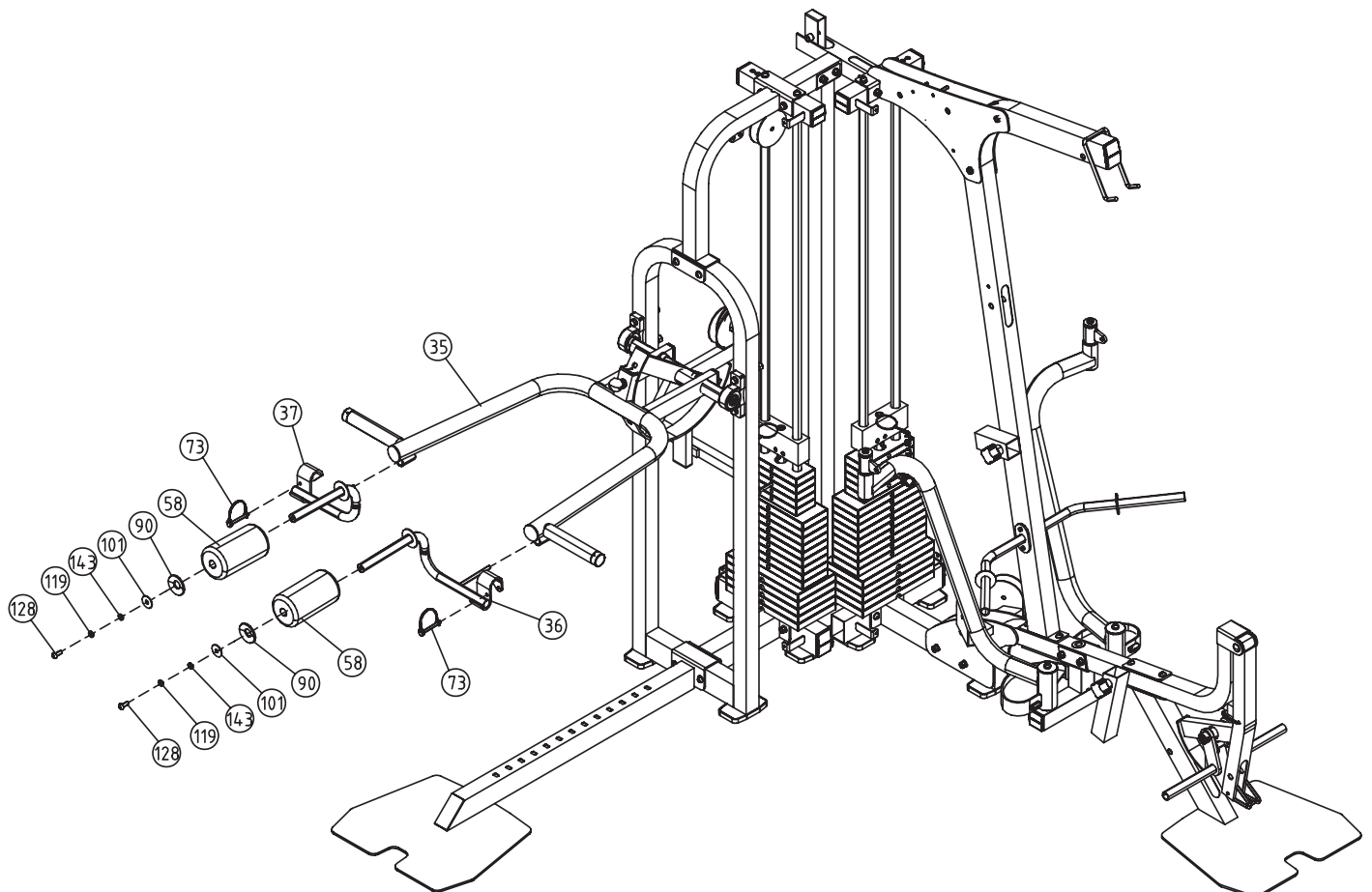

Step 16

Attach Back Pad (51) to Back Pad Adjustment Bracket (28) using two Washers (143) and two Bolts (127).

Attach Seat Pad (50) to Seat Pad Support (27) using two Washers (143) and two Allen Bolts (127).

Slide both assemblies into receptacles as shown in *Figure 16*.

Figure 16

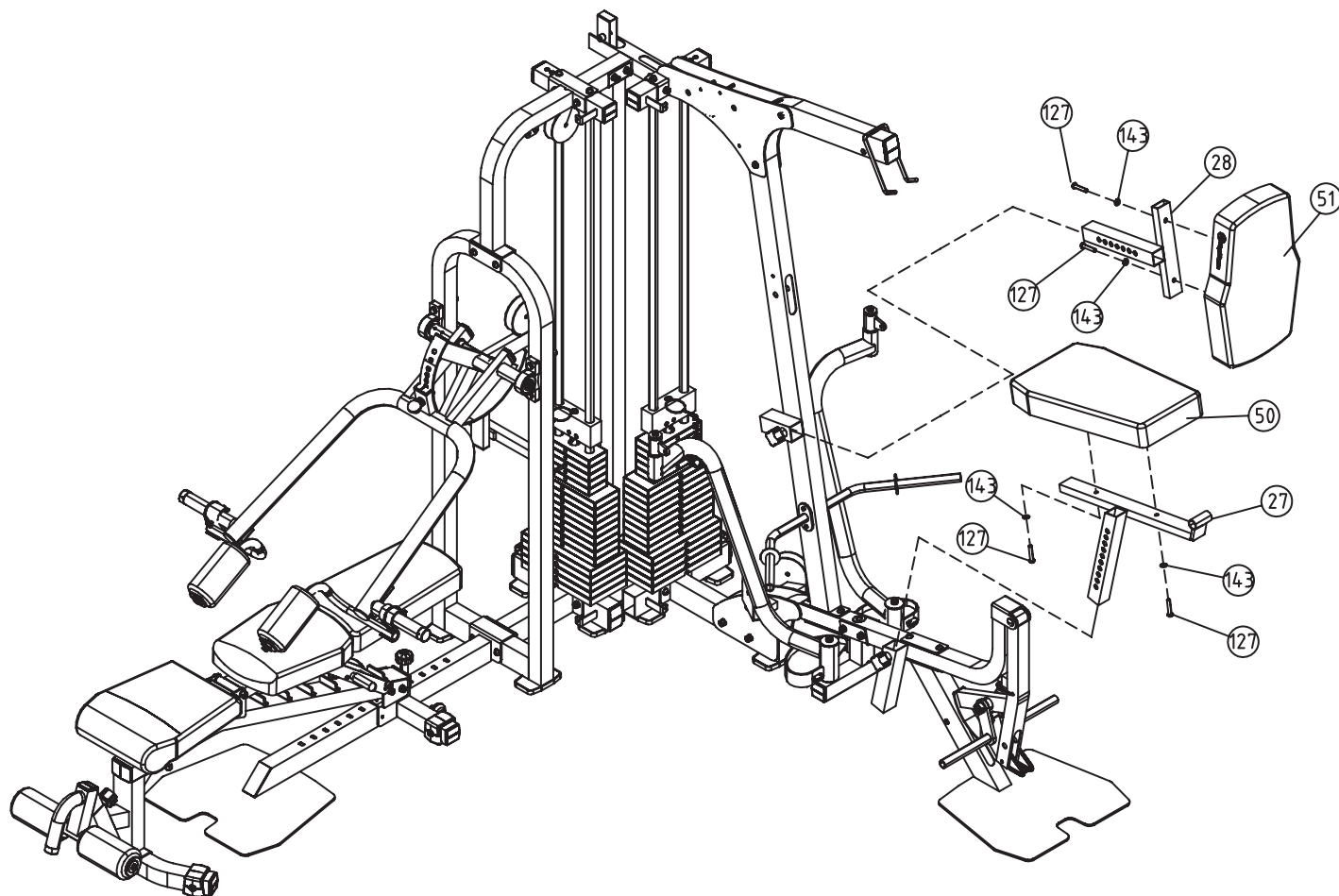

Step 17

Slide two Upholstered Roller Pads (58) onto Foam Frames and secure using two Big Plugs (89).

Slide the Long Foam Tube (34) through the hole in Seat Pad Support. Next, slide two Plastic Washers (90), two Upholstered Roller Pads (58), and two Big Plugs (89) onto each end of Long Foam Tube (34).

Next, slide two Upholstered Roller Pads (58) onto each side of Leg Hold Frames and secure using two Big Plugs (89).

Figure 17

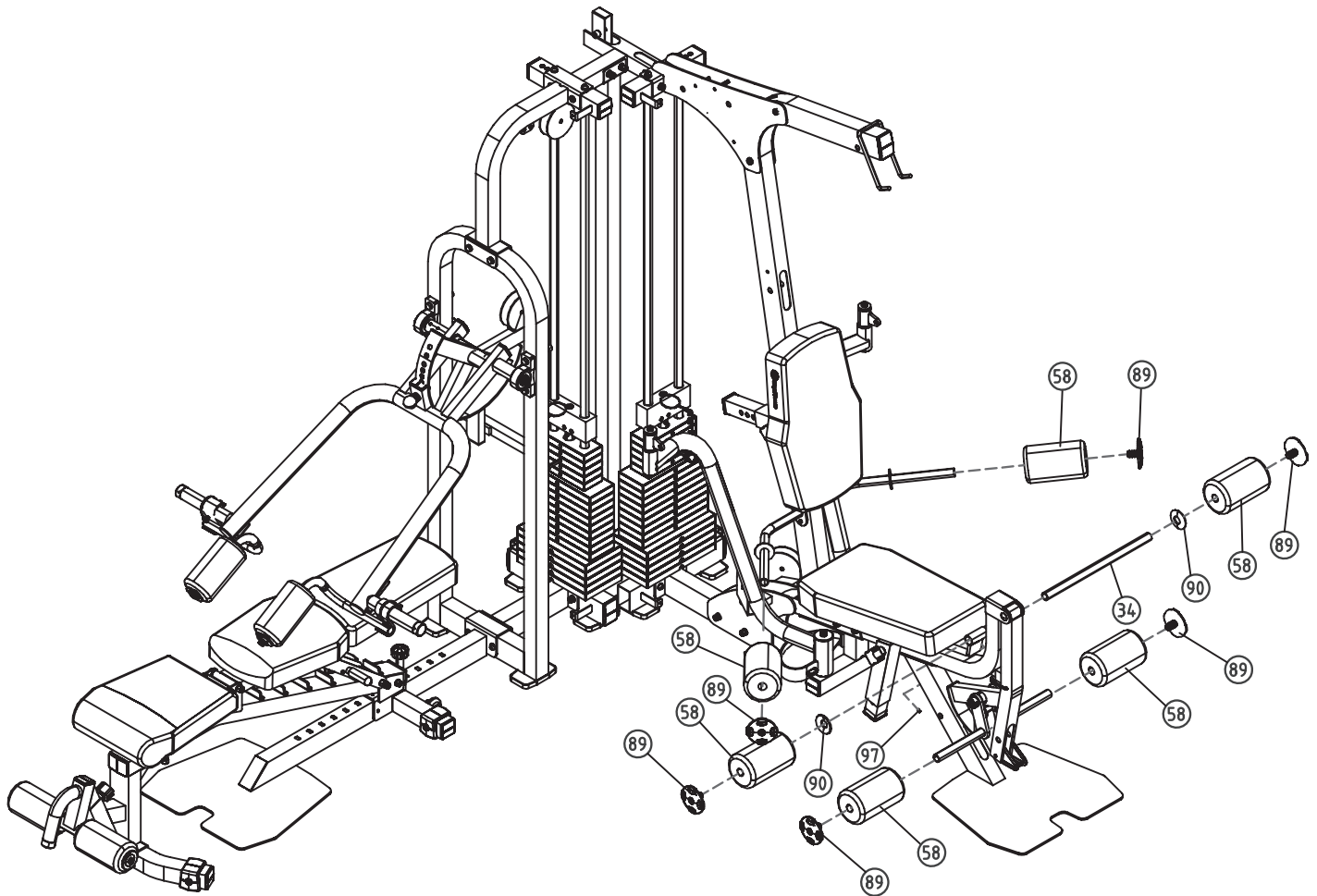

Step 18

Note: Stretch all cables out completely and make sure all twisting is removed before installing.

Install Lat Cable (110) as detailed in *Figure 18*. Follow dotted lines to identify exact location of pulleys. See Page 43 "Cable View" for more detail.

Start by threading cable end into Top Plate (55).

You will need the following for installation:

- | | |
|-------------------------------------|---------------------|
| Pulley (57) - Qty. 7 | Bolt (134) - Qty. 2 |
| Cable (110) - Qty. 1 | Bolt (135) - Qty. 1 |
| Nut (144) - Qty. 7 | Bolt (136) - Qty. 1 |
| Long Pulley Spacer (123) - Qty. 4 | Bolt (137) - Qty. 1 |
| Longer Pulley Spacer (121) - Qty. 4 | Bolt (141) - Qty. 2 |
| Washer (143) - Qty. 14 | |

Figure 18

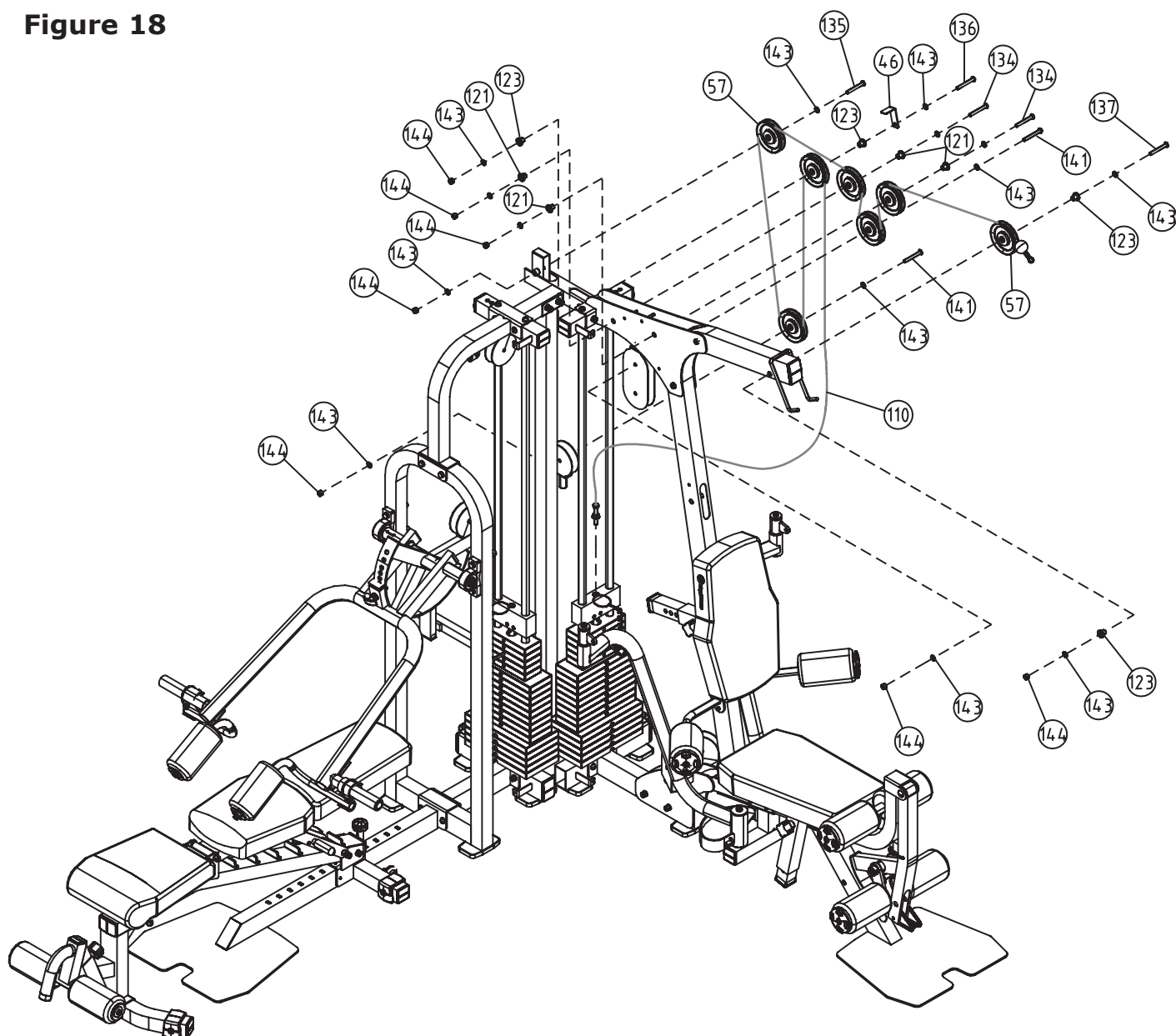

Step 19

Note: This step is only used if you **do not** have the Leg Press 3 attachment. If you do have Leg Press 3 attachment, please follow instructions located in that manual. Use the Cable Adapter (124) in place of the pulley.

Note: Stretch all cables out completely and make sure all twisting is removed before installing.

Install Leg Press Cable Substitute (113) as detailed in *Figure 19*. Follow dotted lines to identify exact location of pulleys.

You will need the following for installation:

Cable Adapter (124) - Qty. 1

Cable (113) - Qty. 1

Washers (143) - Qty. 2

Nut (144) - Qty. 1

Pulley Bracket with Shaft (33) Qty. 1

Bolt (139) - Qty. 1

Nylon Locknut (143) - Qty. 1

Figure 19

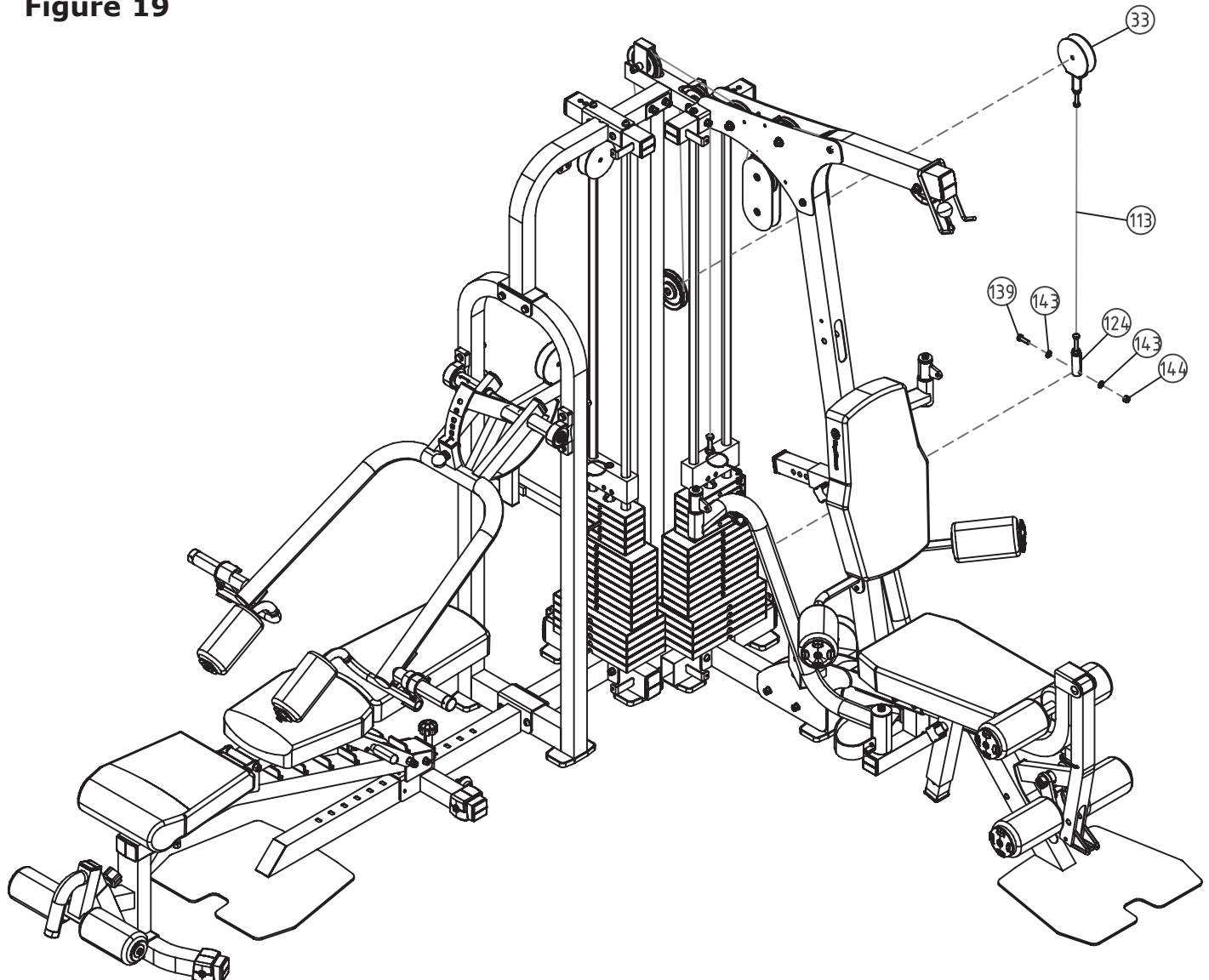

Step 20

Note: Stretch all cables out completely and make sure all twisting is removed before installing.

Install Low Row Cable (111) as detailed in *Figure 20*. Follow dotted lines to identify exact location of pulleys. See *Page 43 "Cable View"* for more detail.

Start by installing cable under the pulley at Leg Extension location.

You will need the following for installation:

- | | |
|--------------------------------------|------------------------|
| Pulley (57) - Qty. 6 | Bolt (134) - Qty. 1 |
| Cable (111) - Qty. 1 | Bolt (136) - Qty. 1 |
| Nut (144) - Qty. 6 | Bolt (137) - Qty. 1 |
| Long Pulley Spacer (123) - Qty. 4 | Bolt (138) - Qty. 1 |
| Longer Pulley Spacer (121) - Qty. 2 | Bolt (141) - Qty. 2 |
| Short Pulley Spacer (122) - Qty. 2 | Washer (143) - Qty. 12 |
| Cable Retainer Bracket (46) - Qty. 1 | |

Figure 20

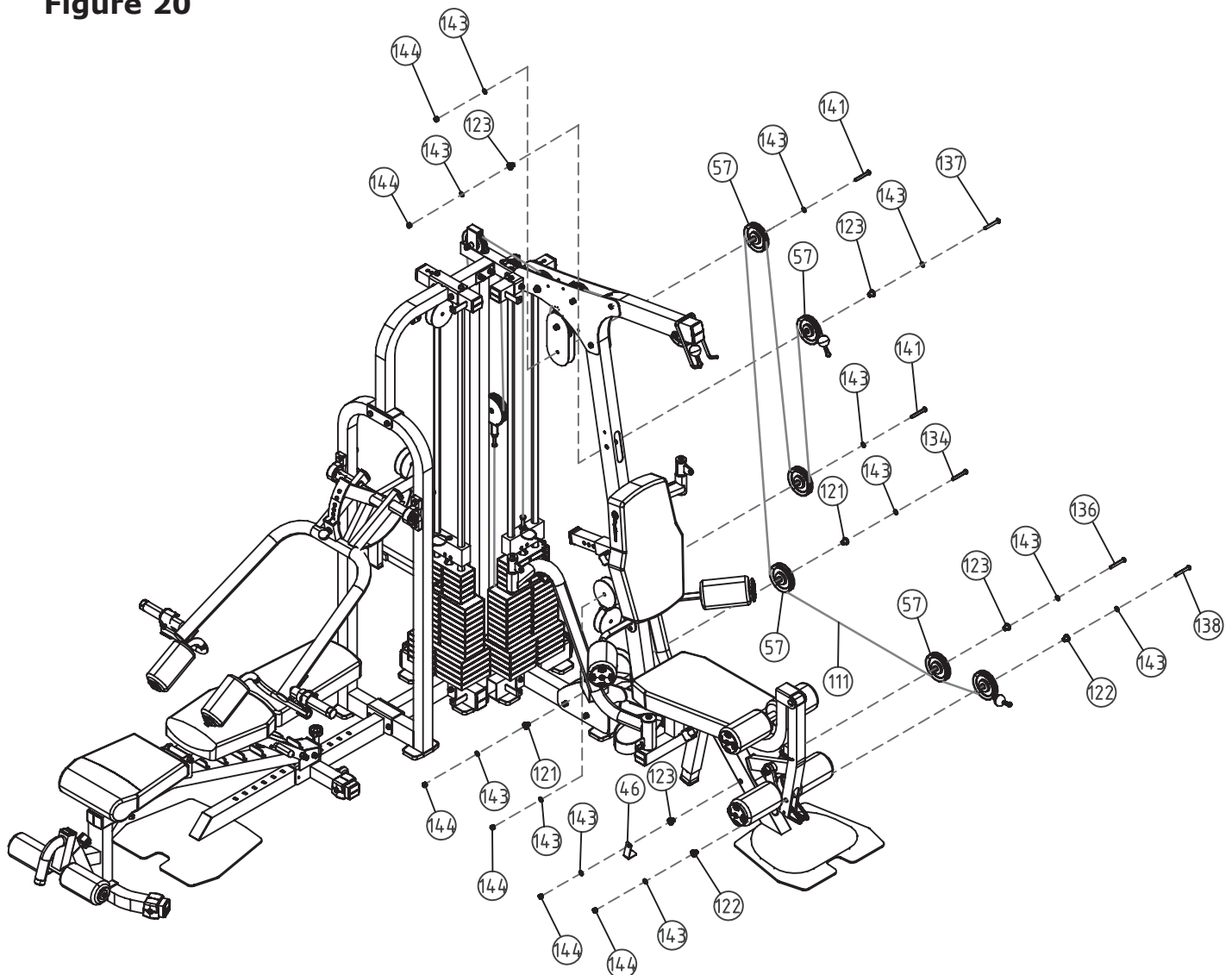

Step 21

Note: Stretch all cables out completely and make sure all twisting is removed before installing.

Install Pec Dec Cable (112) as detailed in *Figure 21*. Follow dotted lines to identify exact location of pulleys.

See Page 43 "Cable View" for more detail.

You will need the following for installation:

Cable (112) - Qty. 1

Pulley (57) - Qty. 3

Bolt (141) - Qty. 3

Washer (143) - Qty. 6

Nut (144) - Qty. 3

Philips Screw (103) - Qty. 2

Figure 21

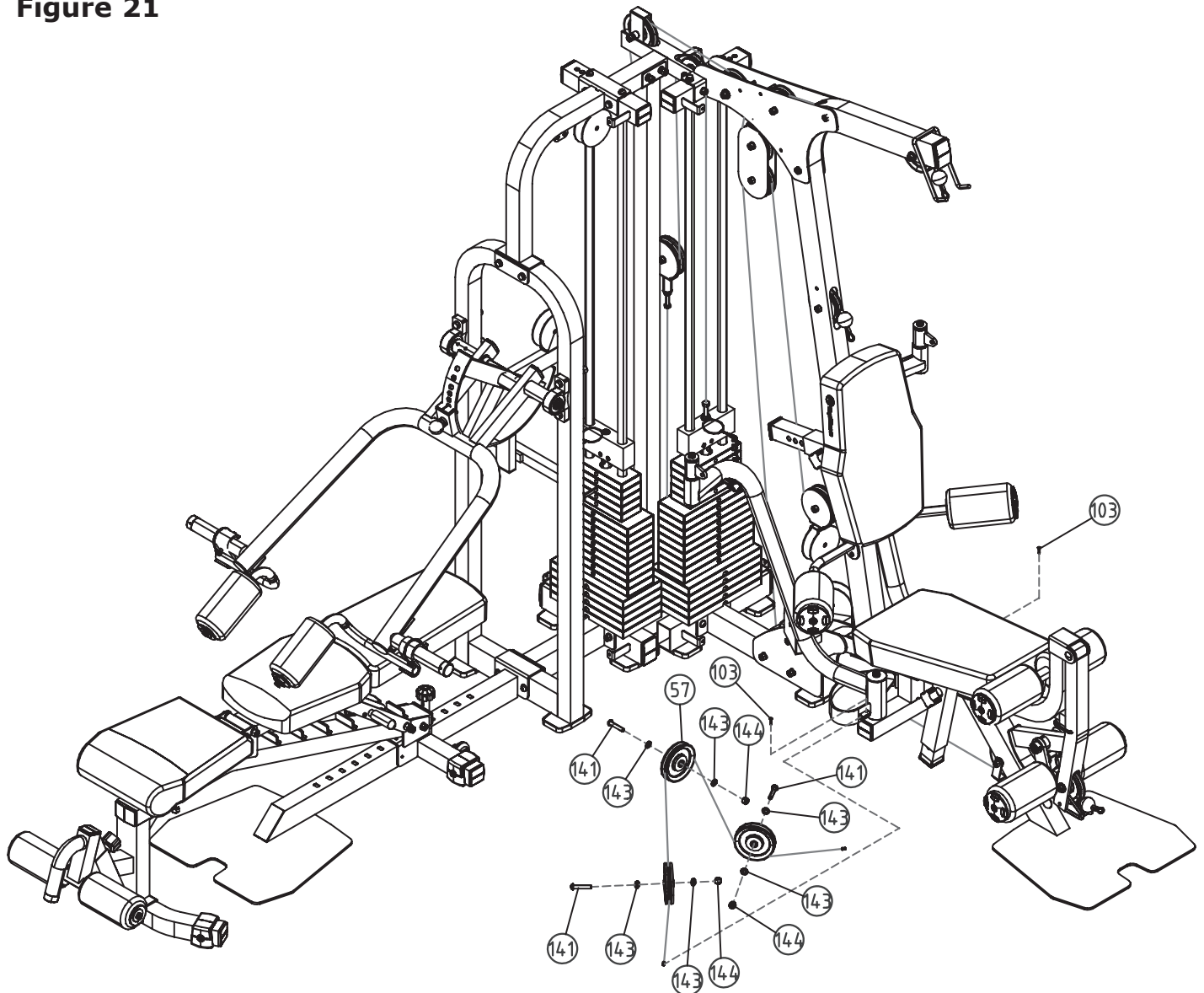

Step 22

Note: Stretch all cables out completely and make sure all twisting is removed before installing.

Install Long Chest Cable (114) as detailed in *Figure 22*. Follow dotted lines to identify exact location of pulleys. See *Page 43 "Cable View"* for more detail.

Start by installing cable into the "Press Station" weight stack.

You will need the following for installation:

Pulley (57) - Qty. 2

Cable (114) - Qty. 1

Nut (144) - Qty. 3

Washer (134) - Qty. 4

Bolt (141) - Qty. 3

Figure 22

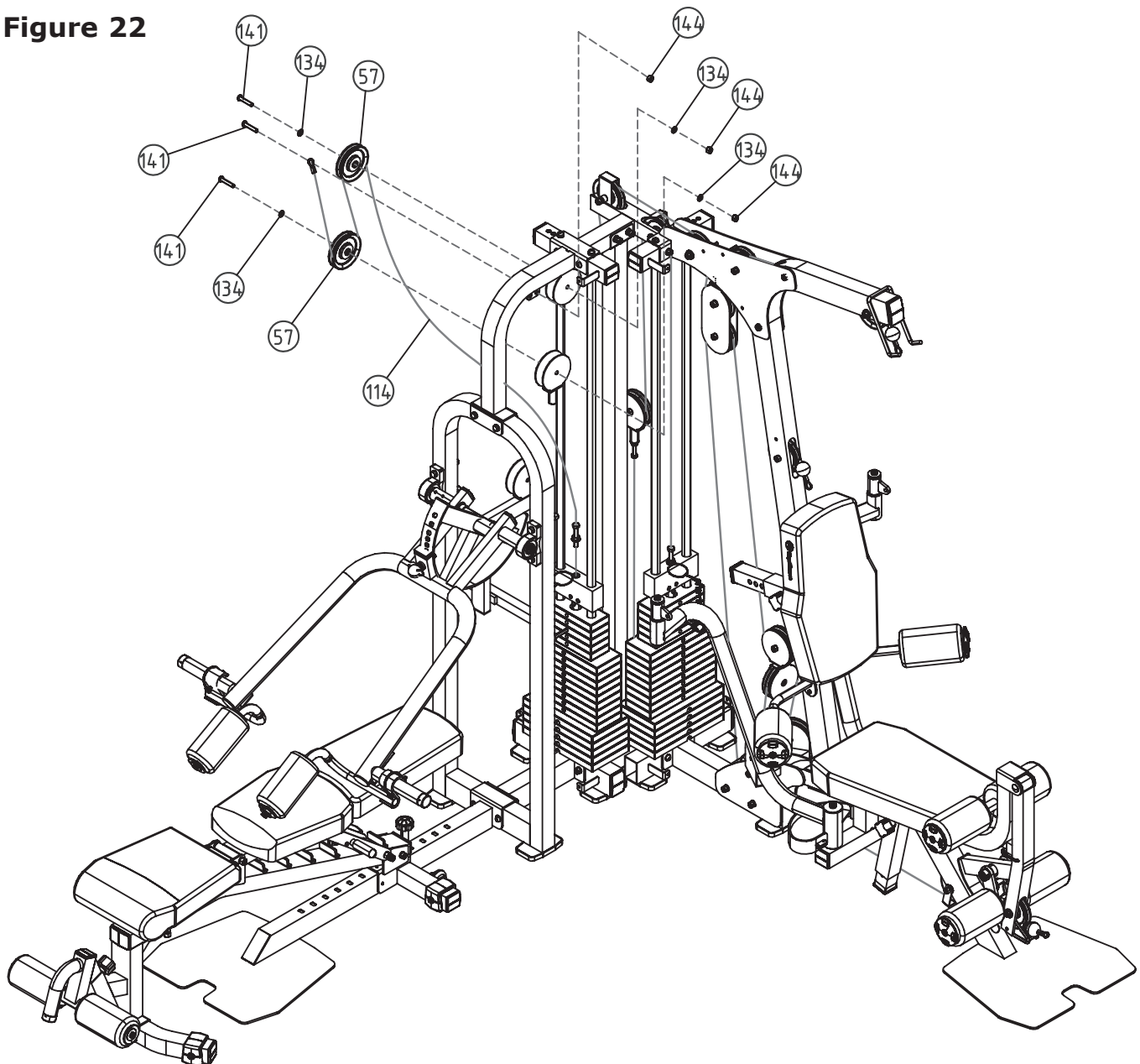

Step 23

Note: Stretch all cables out completely and make sure all twisting is removed before installing.

Install Short Chest Cable (115) as detailed in *Figure 23*. Follow dotted lines to identify exact location of pulleys. See *Page 43 "Cable View"* for more detail.

Start by threading the cable into the floating pulley bracket.

You will need the following for installation:

Pulley (57) - Qty. 1

Cable (115) - Qty. 1

Nut (144) - Qty. 2

Washer (134) - Qty. 2

Bolt (141) - Qty. 2

Figure 23

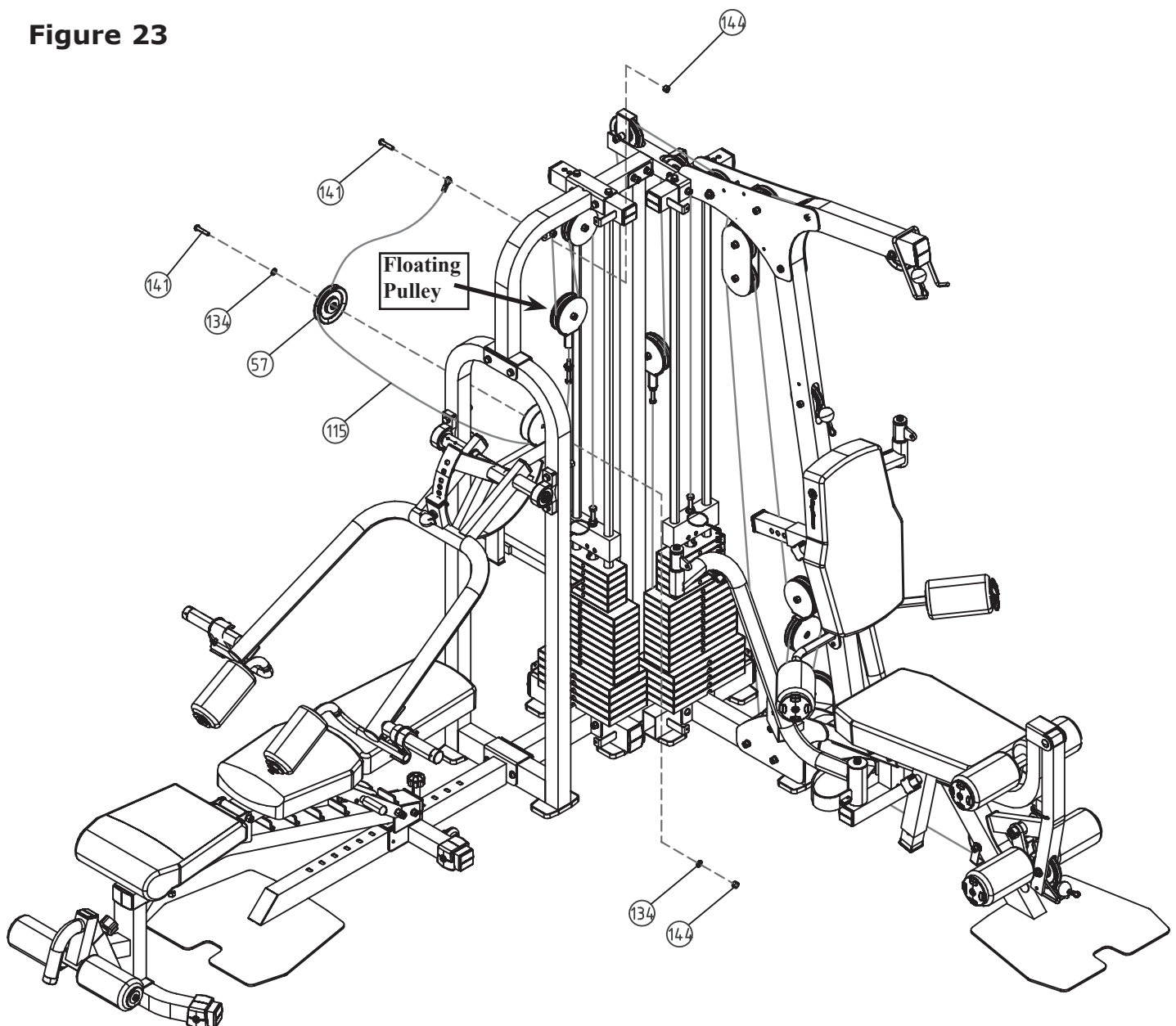

Step 24

Connect Long Lat Bar (43) to the Lat Cable (110) using two Gear Hooks (87) and Short Chain (88).

Connect Ab Strap (60) or Lat Strap (61) to Low Row Cable (111) using one Gear Hook (87).

Connect Short Lat Bar (44) or Ankle Strap (62) to Low Row Cable (111) using two Gear Hooks (87) and Long Chain (116).

Figure 24

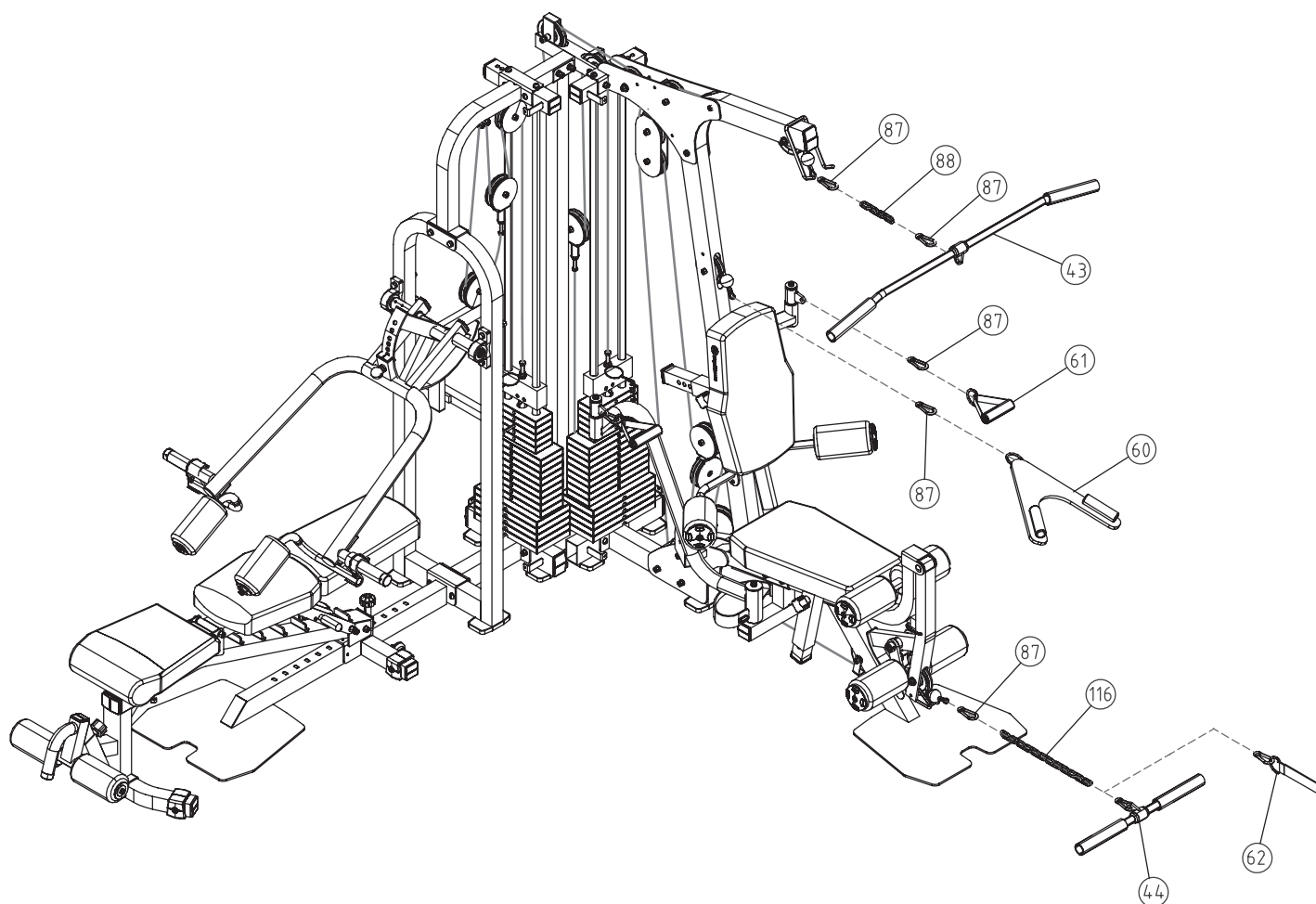

Step 25

Install Weight Shrouds (41) to the left and right side of the weight stacks using four Washers (117) and four Bolts (98).

Install Weight Shroud (42) to the center of both weight stacks and secure using four Washers (117) and four Bolts (98).

Figure 25

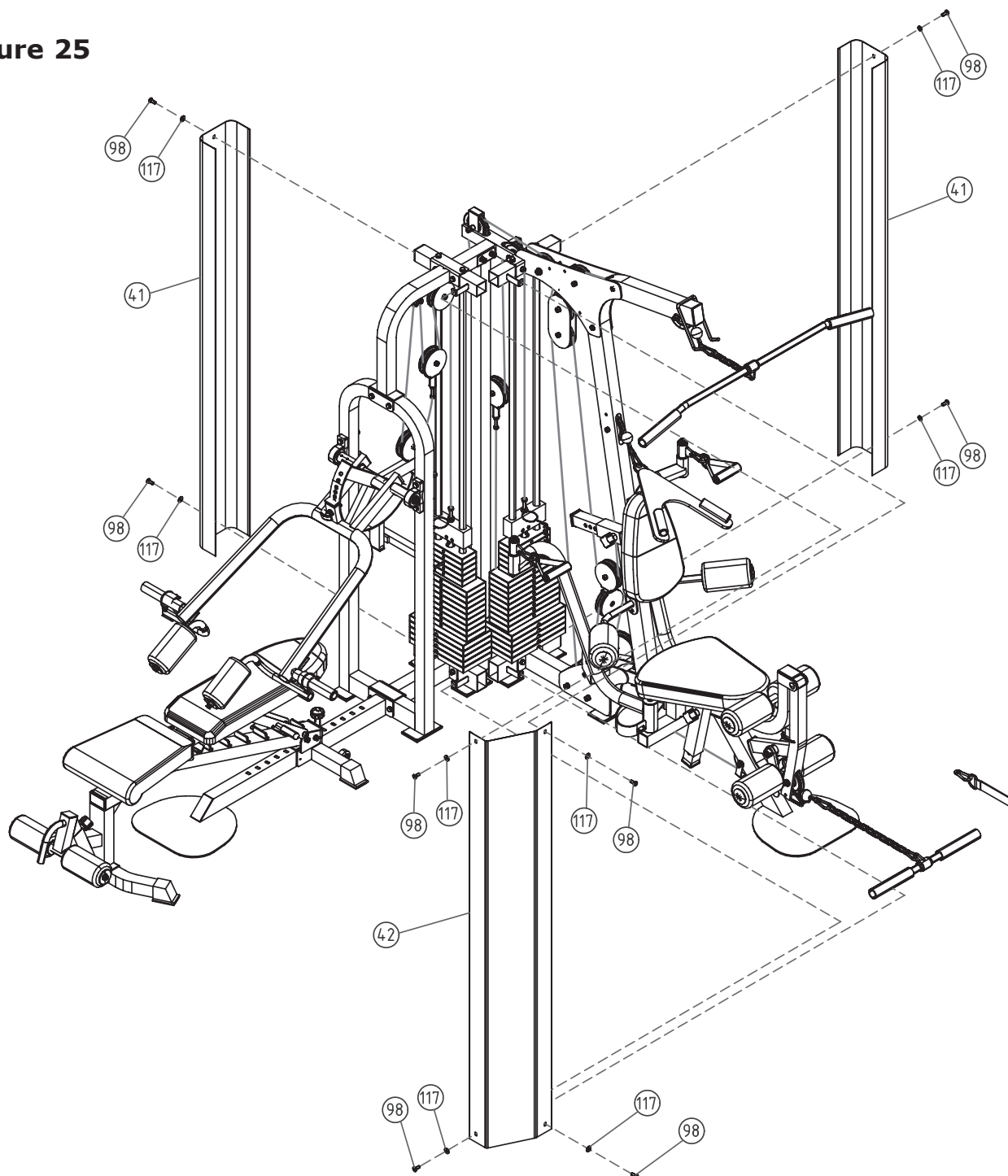

Note: Tighten all hardware securely.

Congratulations!

You have completed the assembly of your new KF-2050.

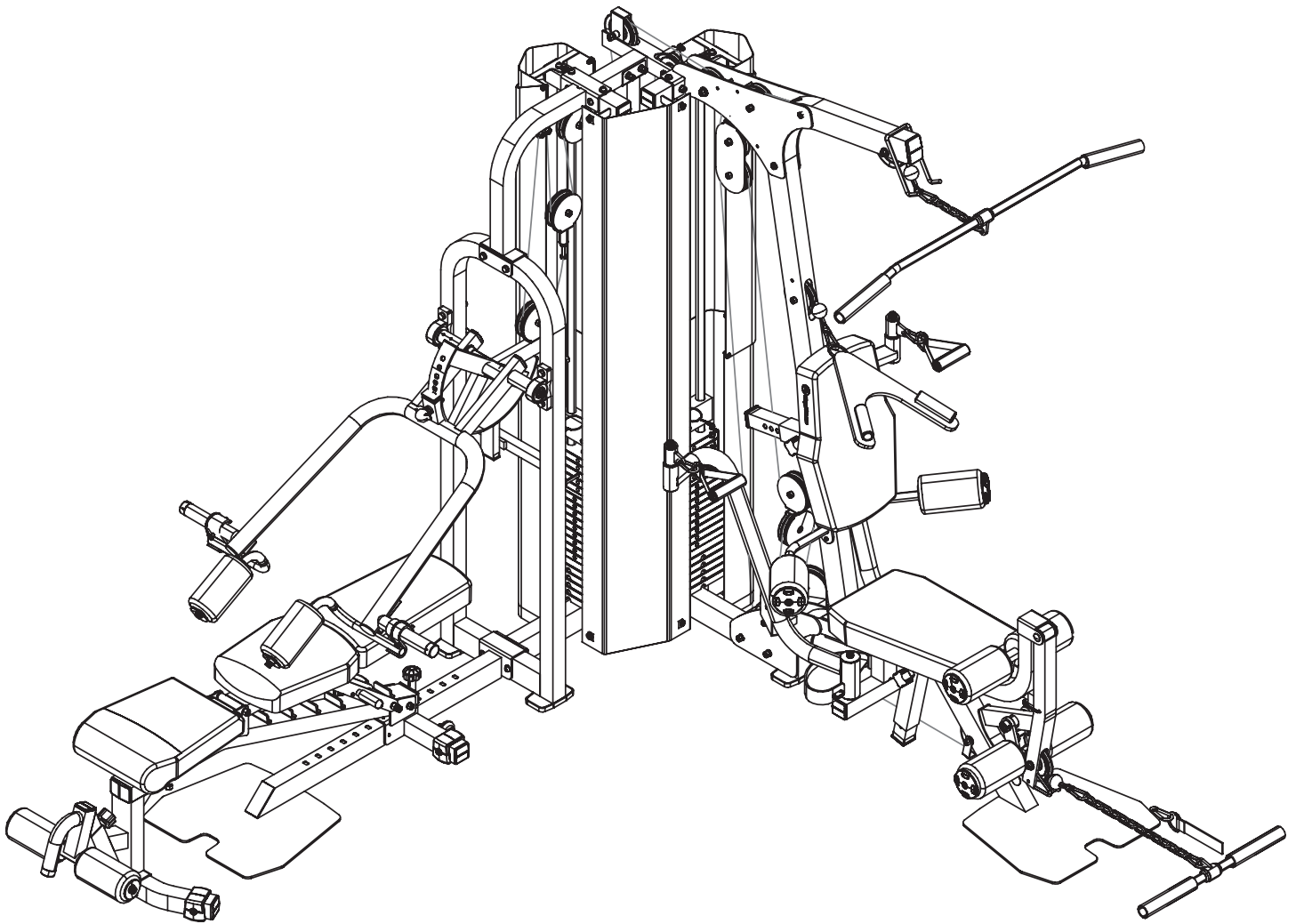

Weight Ratios

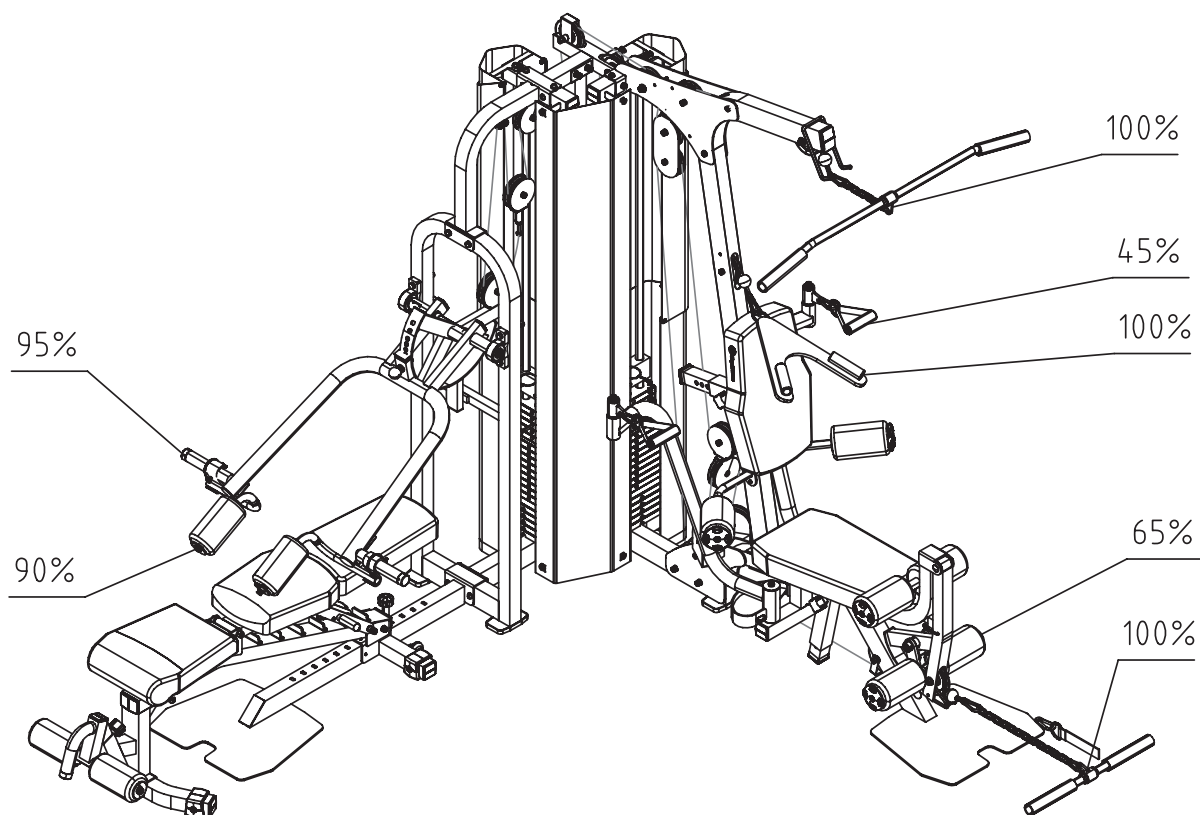

	100%	95%	90%	65%	45%
1	10	9.5	9	6.5	4.5
2	15	14	13.5	10	7
3	20	19	18	13	9
4	25	24	23	16	11
5	30	29	27	20	14
6	35	33	32	23	16
7	45	43	41	29	20
8	55	52	50	36	25
9	65	62	59	42	29
10	75	71	68	49	34
11	85	81	77	55	38
12	95	90	86	62	43
13	105	100	95	68	47
14	115	110	104	75	52
15	125	119	113	81	56
16	140	133	126	91	63
17	155	147	140	101	70
18	170	162	153	111	76
19	185	176	167	120	83
20	200	190	180	130	90

KF2060

Weight Stack Sticker Placement

Your new POWER SYSTEM unit can be purchased with either a 200 LB or 250 LB weight stack. Depending on which weight stack you have purchased will determine which weight stack sticker numbers will be used.

The weight stack images below show which weight stack sticker numbers are to be used on your weight stack. Please note that these stickers should not be put on until the entire unit has been assembled and all bolts and nuts have been tightened.

200 LB Stack

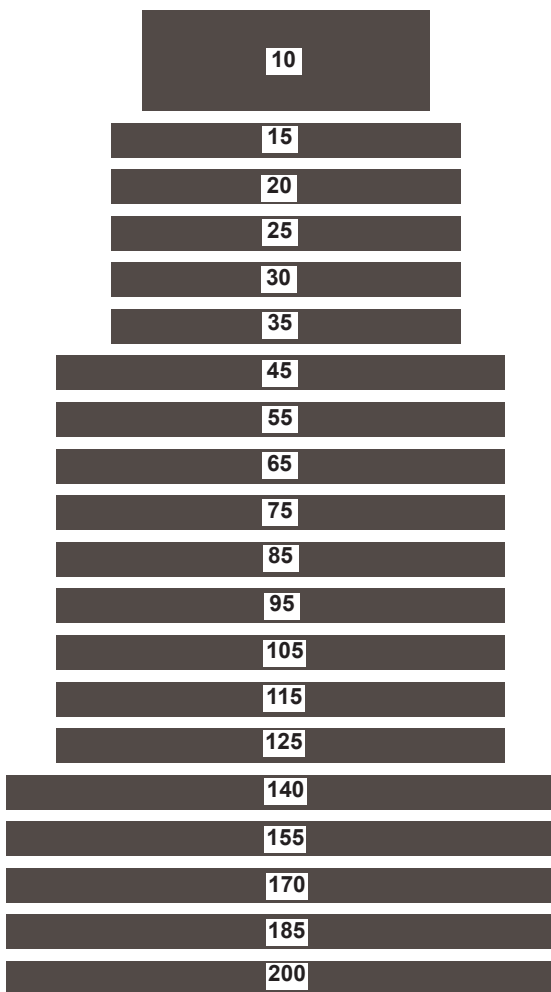

250 LB Stack

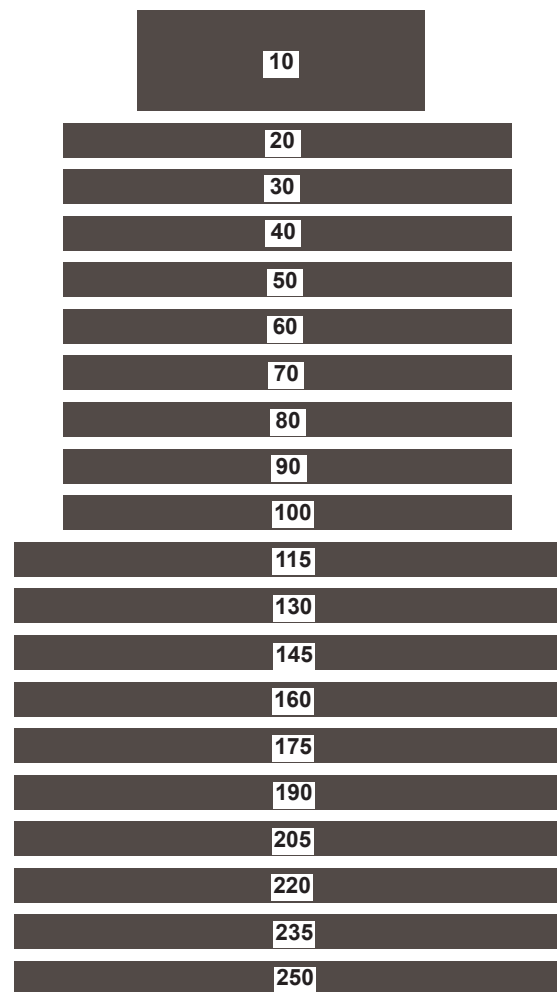

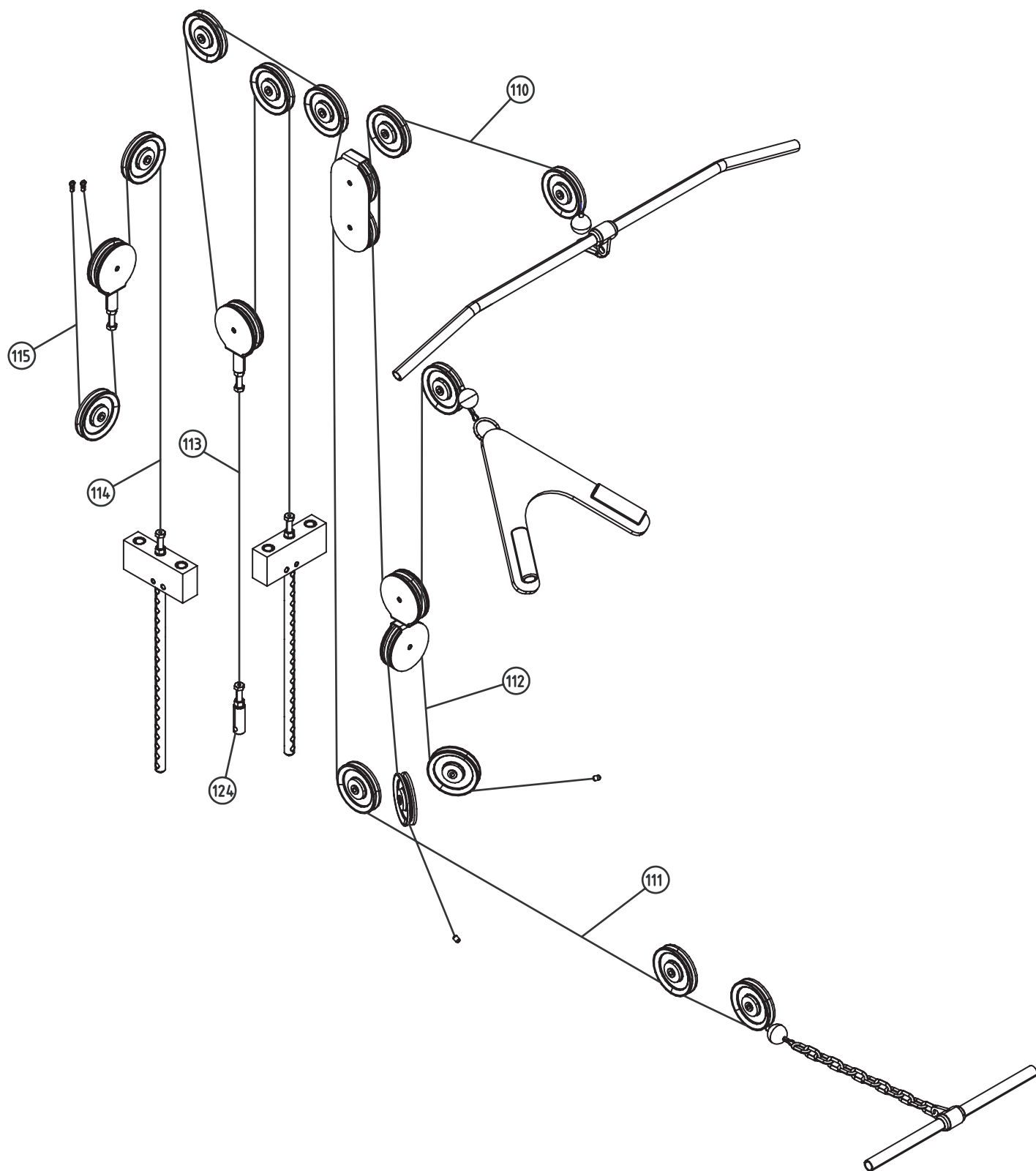

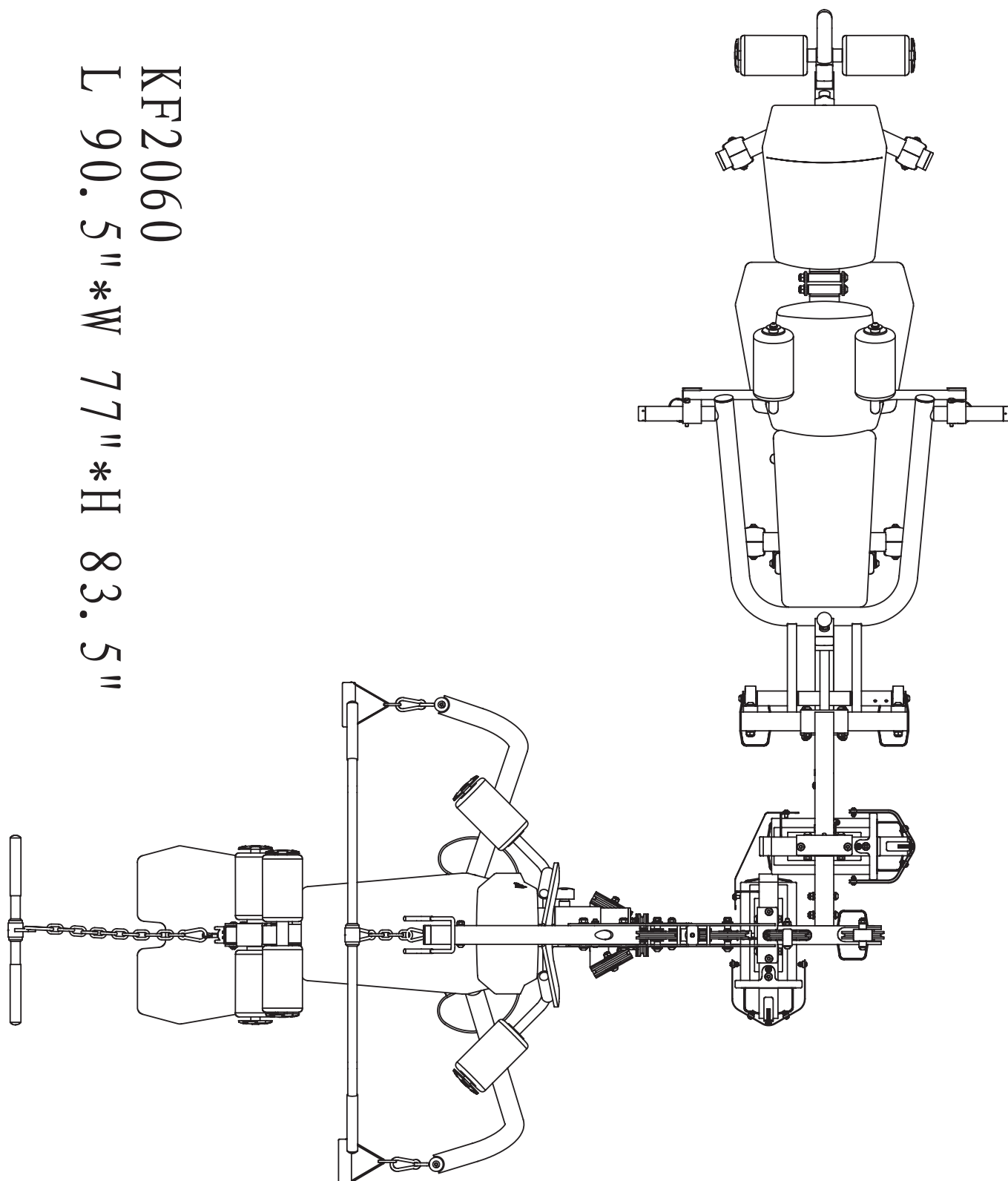

KF2060
L 90.5" * W 77" * H 83.5"

Exploded View

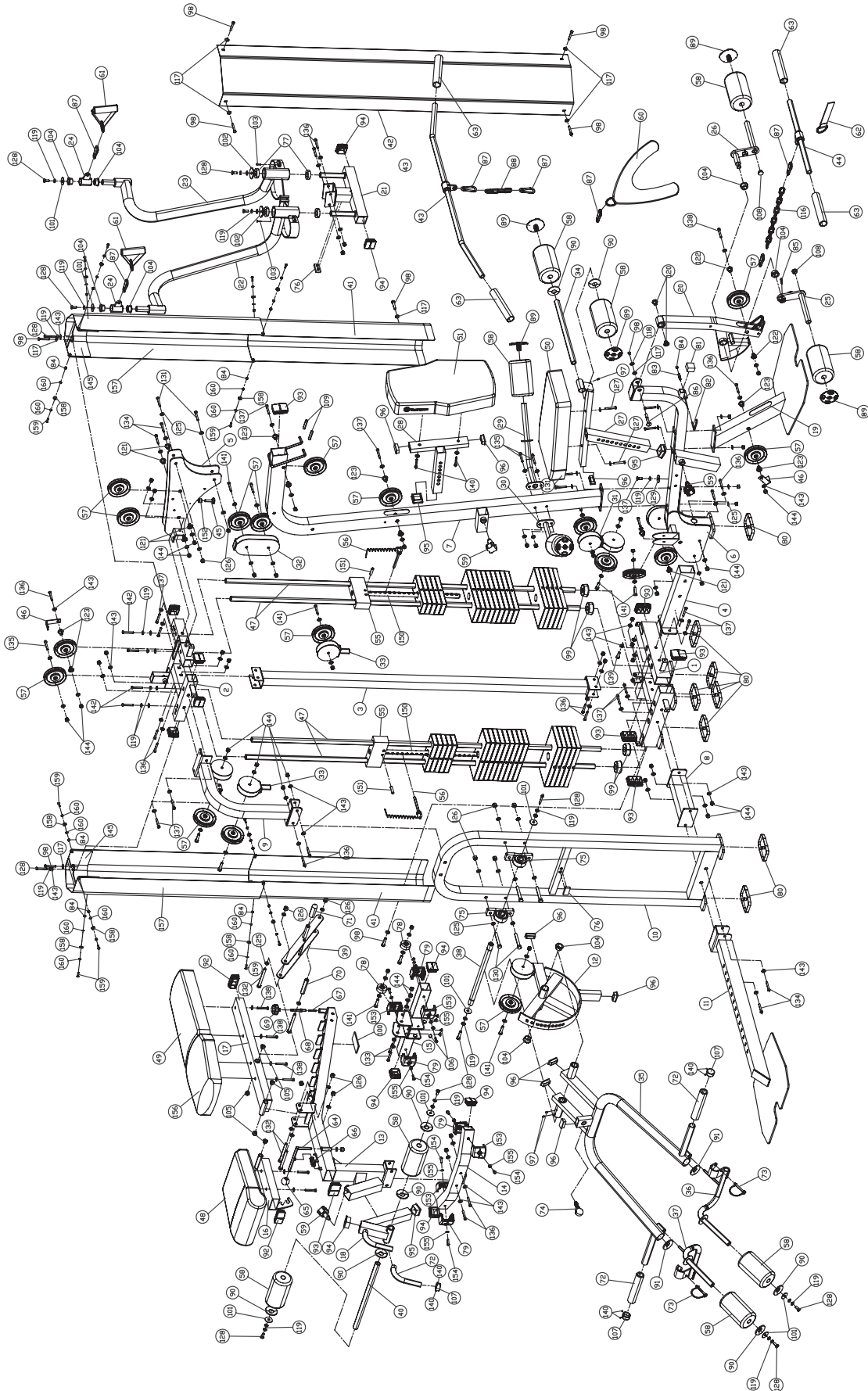

KF-2060 Parts List Rev A

Ref #	Part #	Description	Qty	Ref #	Part #	Description	Qty
1	223-01077	FRAME, REAR KF-2060	1	85	206-00056	SHORT HANDLE GRIPS KPS-1800	1
2	223-01078	FRAME, UP KF-2060	1	86	230-00022	SHAFT FOR LEG EXT. KPS-2050	1
3	223-01079	UPRIGHT, REAR KF-2060	1	87	210-00008	GEAR HOOK, KPS, 210-00008	7
4	223-01080	FRAME, RIGHT BASE KF-2060	1	88	229-00037	SHORT CHAIN	1
5	223-01081	FRAME, RIGHT TOP FOR GUIDE RODKF-2060	1	89	206-00390	PLUG, ROLLER PAD TUBE CAP, KF SERIES	6
6	223-01093	RECEPTACLE, SEAT PAD SUPPORT KF-2060	1	90	206-00134	PLASTIC WASHER KPS-2050/1850	8
7	223-01084	UPRIGHT, MAIN KF-2060	1	91	206-00489	PLUG 50 KF-2060	2
8	223-01085	FRAME, LEFT BASE KF-2060	1	92	206-00490	PLUG, 40X80 KF-2060	2
9	223-01095	FRAME, LEFT TOP FRAME GUIDE ROD KF-2060	1	93	206-00394	PLUG, 50.8X76.2 KF SERIES	7
10	223-01092	SUPPORT, PRESS ARM KF-2060	1	94	206-00391	SQUARE PLUG, 50.8 KF SERIES	10
11	223-01089	FRAME, PRESS STATION BASE KF-2060	1	95	206-00491	PLUG, 44.5 KF-2060	4
12	219-00611	CAM, CHEST PRESS KF-2060	1	96	206-00492	PLUG, 25X50 KF-2060	8
13	223-01086	FRAME, BENCH MAIN KF-2060	1	97	202-00143	SCREW, M8*6	3
14	223-01087	FRAME, BENCH FRONT KF-2060	1	98	202-00727	SCREW, BUTTON HD SOCKET CAP M8X15	9
15	223-01088	FRAME, BENCH REAR KF-2060	1	99	206-00026	WEIGHT BUMPER KPS	4
16	219-00615	SUPPORT, BENCH SEAP PAD KF-2060	1	100	206-00153	RUBBER MAT KPS-2050	1
17	219-00614	SUPPORT, BACK PAD (BENCH) KF-2060	1	101	202-00678	WASHER, CHROME 38X11X2	9
18	219-00617	BRACKET, ADJUSTABLE FOAM KF-2060	1	102	202-00145	BIG WASHER, 56.5*10.5*5	2
19	223-00956	UPRIGHT, FRONT KF-1860	1	103	202-00122	PHILLIP SCREW, M4*20	2
20	223-00244	LEG EXTENSION LEVER KPS-1850	1	104	202-00016	BRONZE ID 25.4	8
21	219-00610	MOUNT, PEC DEC KF-2060	1	105	202-00023	BRONZE BUSHING, ID 12.2	6
22	223-00955	PEC DEC ARM, LEFT KF-1860	1	106	206-00131	PLASTIC BUTTON	14
23	223-00954	PEC DEC ARM, RIGHT KF-1860	1	107	202-00675	CAP, ALUMINUM 32	3
24	219-00272	PEC DEC HANDLE BAR KPS-1850/1550	2	108	206-00138	ROUND PLUG 25	2
25	219-00265	FOAM FRAME W/SHAFT KPS-1850/1550	1	109	206-00136	RUBBER STOPPER	2
26	219-00266	FOAM FRAME W/O SHAFT KPS-1850/1550	1	110	229-00053	LAT CABLE KPS-2050 P110	1
27	219-00612	SUPPORT, SEAT PAD (PEC DEC) KF-2060	1	111	229-00054	LOW ROW/ABDOMINAL CABLE KPS-2050 P111	1
28	219-00613	BRACKET, BACK PAD ADJ (PEC DEC) KF-2060	1	112	229-00050	PEC DEC CABLE KPS-2050/1850	1
29	223-01090	FRAME, RIGHT LEG HOLD LEG KF-2060	1	113	229-00049	LEG PRESS CABLE SUBSTITUTE KPS-2050/1850	1
30	223-01091	FRAME, LEFT LEG HOLD LEG KF-2060	1	114	229-00056	SHORT CHEST CABLE KPS-2050	1
31	219-00274	PULLEY BRACKET BLOCK KPS-1850	1	115	229-00056	SHORT CHEST CABLE KPS-2050	1
32	219-00275	PULLEY BRACKET KPS-1850	1	116	229-00038	LONG CHAIN 12	1
33	219-00273	PULLEY BRACKET W/SHAFT KPS-1850	2	117	202-00137	WASHER, 9*22*2	7
34	230-00008	LONG FOAM TUBE, 219-00070	1	118	202-00134	SPRING WASHER 8	1
35	223-01083	PRESS ARM, KF-2060	1	119	202-00100	SPRING WASHER, M10	17
36	223-00011	RIGHT SQUAT ARM KPS-2000 #35	1	120	202-00141	BRONZE BUSHING, ID16	2
37	223-00010	LEFT SQUAT ARM KPS-2000 #34	1	121	202-00140	LONG PULLEY SPACER	6
38	230-00021	PRESS STATION SHAFT KPS-2050/2000	1	122	202-00025	SHORT PULLEY SPACER - KPS	2
39	219-00034	BENCH BACK PAD ADJ. FRAME KPS-2000	1	123	202-00071	LONG PULLEY SPACER - KPS GYMS	8
40	219-00288	FOAM BRACKET KPS-2050	1	124	210-00093	CABLE ADAPTOR	1
41	223-00959	WEIGHT SHROUD, BOTTOM KF-1860	2	125	202-00127	WASHER, 13*24*1.5	25
42	223-01094	SHROUD, WEIGHT B KF-2060	1	126	202-00092	NYLON NUT, M12	13
43	223-00092	LAT BAR KPS-GYM, 223-00574	1	127	202-00664	SCREW, BUTTON HEAD SOCKET CAP M10X50	2
44	223-00099	SHORT BAR	1	128	202-00662	SCREW, BUTTON HEAD SOCKET CAP M10X25	12
45	210-00097	ADJUSTABLE STOPPER, KPS	1	129	202-00130	WASHER, BIG 11*38*2	8
46	219-00281	CABLE RETAINER KPS-1850/2050	2	130	202-00685	SCREW, BUTTON HD SOCKET CAP M12X90	4
47	223-00247	GUIDE ROD KPS-1850	4	131	202-00657	SCREW, BUTTON HEAD SOCKET CAP M12X80	4
48	228-00248	PAD, SEAT (BENCH) KF-2060	1	132	202-00639	SCREW, M12X125 BUTTON HEAD SOCKET CAP	4
49	228-00247	PAD, UPPER BACK KF-2060	1	133	202-00726	SCREW, BUTTON HD SOCKET CAP M10X105	2
50	228-00219	SEAT PAD, KF-1860	1	134	202-00700	SCREW, BUTTON HD SOCKET CAP M10X85	6
51	228-00218	BACK PAD, KF-1860	1	135	202-00634	SCREW, M10X80 BUTTON HEAD SOCKET CAP	7
55	223-00031	TOP PLATE KPS-GYM	2	136	202-00647	BUTTON HEAD SOCKET CAP SCREW M10X75	12
56	210-00004	WEIGHT PIN	2	137	202-00637	SCREW, M10X70 BUTTON HEAD SOCKET CAP	11
57	223-00228	BIG PULLEY 4.5"	19	138	202-00665	SCREW, BUTTON HEAD SOCKET CAP M10X65	7
58	206-00395	FOAM PADDING, 100X22X180 KF SERIES	10	139	202-00716	SCREW, BUTTON HD SOCKET CAP M10X60	1
59	210-00029	POP PIN LOCKING	3	140	202-00674	SCREW, 10-32X3.2	6
60	210-00099	AB STRAP KPS-2050/1850/1550	1	141	202-00658	SCREW, BUTTON HEAD SOCKET CAP M10X45	12
61	210-00061	HAND STRAP INRAY GYM	2	142	202-00635	SCREW, M10X30 BUTTON HEAD SOCKET CAP	4
62	210-00059	ANKLE STRAP INRAY GYM	1	143	202-00128	WASHER, 11*20*2	128
63	206-00103	LAT BAR GRIP - KPS	4	144	202-00091	NYLON NUT, M10	52
64	219-00616	BAR, BENCH SEAT PAD ADJ KF-2060	1	145	223-00957	WEIGHT SHROUD, TOP KF-1860	2
65	206-00467	BALL HEAD, KF-OB	1	146	202-00132	HEX KEY 6	1
66	202-00156	SPRING, 1.5*13*43, KPS-2050	1	147	202-00133	HEX KEY 4	1
67	202-00149	SPRING, 1*13*38, KPS-2050	1	148	210-00094	LUBE	1
68	202-00157	PIN SHAFT, KPS-2050	1	150	219-00276	SELECTOR ROD INRAY-GYMS	2
69	206-00146	PIN KNOB KPS-2050	1	151	202-00212	SCREW BOLT, M12*35	2
70	206-00148	NYLON SPACER KPS-2050	1	152	202-00129	REGULAR HEX NUT 10	1
71	206-00052	SMALL GRIPS	1	153	206-00392	FOOT CAP, RIGHT 50.8 KF SERIES	4
72	206-00053	LONG GRIPS KPS-2000	3	154	202-00636	SCREW, M8X25 BUTTON HEAD SOCKET CAP	8
73	210-00001	SAFETY PIN KPS	2	155	202-00224	WASHER, 9X16X1.6	8
74	210-00262	POP PIN, PRESS ARM KF-2060	1	156	228-00246	PAD, LOWER BACK KF-2060	1
75	202-00030	PILLOW BLOCK BEARING (BLACK)	2	157	223-00958	WEIGHT SHROUD, MIDDLE KF-1860	2
76	206-00143	PEC DEC STOP BUMPER KPS-2050	2	158	202-00677	SMALL SPACER, KF-1860	16
77	202-00024	BEARING ID 25	4	159	202-00676	SCREW, BUTTON HD SOC CAP M6X18	16
78	206-00150	CASTER BLACK KPS-2050	2	160	202-00227	WASHER, 6.6X12X1.6	32
79	206-00393	FOOT CAP, LEFT 50.8 KF SERIES	4	161	202-00703	HEX KEY 5	1
80	206-00061	BASE PAD KPS	8	162	202-00696	HEX KEY 8	1
81	206-00099	END CAP BUMPER - KPS	1	163	202-00728	HEX KEY 3/32"	1
82	202-00147	U PIN	1	#	202-00730	BOLT PACK, KF-2060 (1)	1
83	202-00155	SPRING, 1*8*35	1	#	202-00731	BOLT PACK, KF-2060 (2)	1
84	202-00142	NUT, M6	17				

KEYS FITNESS PRODUCTS, L.P. LIFETIME WARRANTY



This Warranty applies in the United States and Canada to products manufactured or distributed by Keys Fitness Products, LP ("Keys") under the KEYS brand name. The warranty is non-transferable and valid only to the original purchaser.

Keys warrants that the Product you have purchased for non-commercial, personal, family, or household use from Keys or from an authorized Keys reseller is free from defects in materials or workmanship under normal use during the warranty period. Your sales receipt, showing the date of purchase of the Product, is your proof of purchase. This warranty only extends to you, the original purchaser. It is not transferable to anyone who subsequently purchases or acquires the Product from you. This Warranty becomes **VALID ONLY** if the product is purchased through a Keys Fitness authorized dealer unless otherwise authorized by Keys Fitness in writing and must be assembled / installed according to the instructions included with the Product.

In a light institutional setting, Keys will extend a one year limited warranty to the original purchaser.

During the warranty period Keys will repair or replace (at Keys' option) the product if it becomes defective, malfunctions, or otherwise fails to conform with this Warranty under normal use. In repairing the Product, Keys may replace defective parts with new or, at the option of Keys, serviceable used parts that are equivalent to new parts in performance. All exchanged parts and Products replaced under this warranty will become the property of Keys. Keys reserves the right to change manufacturers of any part to cover any existing warranty.

This warranty **DOES NOT COVER** shipping charges, export taxes, custom duties and taxes, or any other charges associated with transportation of the parts or Product. To obtain warranty service, you must contact a Keys authorized retailer, service technician or Keys Fitness at our phone number located in this manual. Any parts determined to be defective must be returned to Keys to obtain warranty service. You must prepay any shipping charges, export taxes, custom duties and taxes, or any other charges associated with transportation of the parts or Product. In addition, you are responsible for insuring any parts or Product shipped or returned. You assume the risk of loss during shipment. You must present Keys with proof-of-purchase documents (including the date of purchase). Any evidence of alteration, erasure or forgery of proof-of-purchase documents will be cause to void this Warranty.

This Warranty does not extend to any product not purchased from Keys or from an authorized Keys reseller. This Limited Warranty does not extend to any Product that has been damaged or rendered defective; (a) as a result of accident, misuse, or abuse; (b) by the use of parts not manufactured or sold by Keys; (c) by modification of the Product; (d) operation on incorrect power supplies; or (e) as a result of service by anyone other than Keys, or an authorized Keys warranty service provider. Product on which the serial number has been defaced or removed is not eligible for warranty service. Should any Product submitted for warranty service be found ineligible, an estimate of repair cost will be furnished and the repair will be made if requested by you upon Keys' receipt of payment or acceptable arrangements for payment.

EXCEPT AS EXPRESSLY SET FORTH IN THIS WARRANTY, KEYS MAKES NO OTHER WARRANTIES, EXPRESSED OR IMPLIED, INCLUDING ANY IMPLIED WARRANTIES OF MERCHANTABILITY AND FITNESS FOR A PARTICULAR PURPOSE. KEYS EXPRESSLY DISCLAIMS ALL WARRANTIES NOT STATED IN THIS LIMITED WARRANTY. ANY IMPLIED WARRANTIES THAT MAY BE IMPOSED BY LAW ARE LIMITED TO THE TERMS OF THIS LIMITED WARRANTY. NEITHER KEYS NOR ANY OF ITS AFFILIATES SHALL BE RESPONSIBLE FOR INCIDENTAL OR CONSEQUENTIAL DAMAGES. SOME STATES DO NOT ALLOW LIMITATIONS ON HOW LONG AN IMPLIED WARRANTY LASTS OR THE EXCLUSION OR LIMITATION OF INCIDENTAL OR CONSEQUENTIAL DAMAGES, SO THE ABOVE LIMITATIONS OR EXCLUSION MAY NOT APPLY TO YOU. This Limited Warranty gives you specific legal rights and you may also have other rights that may vary from state to state. This is the only express warranty applicable to Keys-branded products. Keys neither assumes nor authorizes anyone to assume for it any other express warranty.

PLEASE SEND IN THE INCLUDED WARRANTY CARD OR REGISTER ON-LINE AT www.keysfitness.com WITHIN TEN (10) DAYS OF PURCHASE TO REGISTER YOUR UNIT WITH KEYS FITNESS PRODUCTS, LP. MAIL WARRANTY CARD TO: KEYS FITNESS PRODUCTS, PO BOX 551239, DALLAS, TX 75355



Keys Fitness Products, L.P.
4009 Distribution Drive, Suite 250
Garland, Texas 75041
Customer Service: 1-888-380-0482

Free Manuals Download Website

<http://myh66.com>

<http://usermanuals.us>

<http://www.somanuals.com>

<http://www.4manuals.cc>

<http://www.manual-lib.com>

<http://www.404manual.com>

<http://www.luxmanual.com>

<http://aubethermostatmanual.com>

Golf course search by state

<http://golfingnear.com>

Email search by domain

<http://emailbydomain.com>

Auto manuals search

<http://auto.somanuals.com>

TV manuals search

<http://tv.somanuals.com>