

KitchenAid®

5

SPEED
VITESSES
VELOCIDADES

BLENDER

INSTRUCTIONS AND RECIPES

MÉLANGEUR

INSTRUCTIONS ET RECETTES

LICUADORA

INSTRUCCIONES Y RECETAS

KSB550, KSB560, KSB570, KSB580

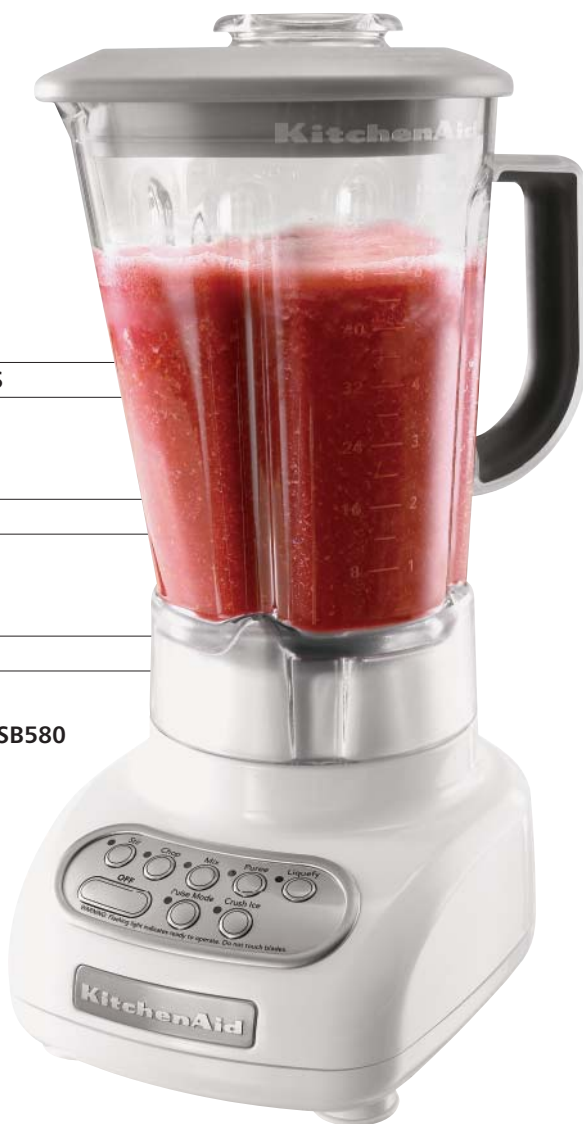

U.S.A./É.-U./EE.UU.:
1-800-541-6390
Canada/Canadá:
1-800-807-6777
9709225B

KitchenAid.com
KitchenAid.ca



FOR THE WAY IT'S MADE.®

Proof of Purchase and Product Registration

Always keep a copy of the sales receipt showing the date of purchase of your blender. Proof of purchase will assure you of in-warranty service.

Before you use your blender, please fill out and mail your product registration card packed with the unit. This card will enable

us to contact you in the unlikely event of a product safety notification and assist us in complying with the provisions of the Consumer Product Safety Act. This card does not verify your warranty.

Please complete the following for your personal records:

Model Number _____

Serial Number _____

Date Purchased _____

Store Name and Location _____

Preuve d'achat et enregistrement du produit

Veillez conserver une copie du coupon de caisse indiquant la date d'achat de votre mélangeur. La preuve d'achat vous assure du service d'après-vente sous garantie.

Avant d'utiliser votre mélangeur, veuillez remplir et poster la carte d'enregistrement du produit accompagnant l'appareil. Grâce à cette carte, nous pourrons vous

appeler dans l'éventualité improbable d'un avis de sécurité et nous conformer plus facilement aux dispositions de la loi sur la sécurité des produits de consommation. Cette carte ne confirme pas votre garantie.

Veillez remplir ce qui suit pour vos dossiers personnels :

Numéro de modèle _____

Numéro de série _____

Date d'achat _____

Nom du marchand et adresse _____

Comprobante de compra y registro del producto

Siempre conserve una copia del recibo de ventas que especifique la fecha de compra de su licuadora. El comprobante de compra le asegurará el servicio técnico bajo garantía.

Antes de utilizar la licuadora, complete y envíe por correo su tarjeta de registro del producto que viene junto con la unidad. Esta tarjeta nos permitirá contactarnos

con usted en el improbable caso de una notificación de algún problema de seguridad con el producto y nos ayudará a cumplir con las cláusulas de la Consumer Product Safety Act (Ley sobre la seguridad de los productos para el consumidor). Esta tarjeta no asegura su garantía.

Complete lo siguiente para su registro personal:

Número del modelo _____

Número de serie _____

Fecha de compra _____

Nombre y dirección de la tienda _____

Table of Contents

INTRODUCTION

Proof of Purchase & Product Registration Card	Inside Front Cover
Blender Safety	3
Important Safeguards	4
Electrical Requirements	5

FEATURES AND OPERATION

Blender Features	6
Preparing the Blender for Use	8
Before First Use	8
Blender Assembly	8
Using the Blender	9
Before Use	9
Operating the Blender	9
Crush Ice Feature	9
Pulse Mode Feature	10
Ingredient Cap	10
Soft Start™ Blending Feature	10
Speed Control Guide	11

CARE AND CLEANING

Cleaning the Blender	12
Troubleshooting	13

BLENDER TIPS

Quick Tips	14
How To	14

Continued on next page

Table of Contents

RECIPES

Blended Margarita	16
Sparkling Cran-Pineapple Drink	16
Strawberry-Banana Smoothie	17
Rum Mocha	17
Italian Tortellini Tomato Soup	18
Blueberry Pancakes and Sauce	19
Raspberry Vinaigrette Dressing	20
Chocolate Pot De Crème	20
Fresh Fruit Milk Shake	21

WARRANTY AND SERVICE INFORMATION

KitchenAid® Blender Warranty	22
Hassle-Free Replacement Warranty – 50 United States and District of Columbia	23
Hassle-Free Replacement Warranty – Canada	23
How to Arrange for Warranty Service in Puerto Rico	23
How to Arrange for Service after the Warranty Expires – All Locations	24
How to Arrange for Service Outside these Locations	24
How to Order Accessories and Replacement Parts	24

NOTE: Due to the unique container and blade design, read these instructions and recipes before using your new KitchenAid® blender to achieve maximum performance results.

Blender Safety

Your safety and the safety of others are very important.

We have provided many important safety messages in this manual and on your appliance. Always read and obey all safety messages.



This is the safety alert symbol.

This symbol alerts you to potential hazards that can kill or hurt you and others.

All safety messages will follow the safety alert symbol and either the word "DANGER" or "WARNING." These words mean:

! DANGER

You can be killed or seriously injured if you don't immediately follow instructions.

! WARNING

You can be killed or seriously injured if you don't follow instructions.

All safety messages will tell you what the potential hazard is, tell you how to reduce the chance of injury, and tell you what can happen if the instructions are not followed.

IMPORTANT SAFEGUARDS

When you are using electrical appliances, basic safety precautions should always be followed to reduce the risk of fire, electric shock, and/or injury to persons including the following:

1. Read all instructions.
2. To avoid the risk of electrical shock, do not put blender in water or other liquid.
3. Close supervision is necessary when any appliance is used by or near children.
4. Unplug from outlet when not in use, before putting on or taking off parts, and before cleaning.
5. Avoid contact with moving parts.
6. Do not operate the blender with a damaged cord or plug or after appliance malfunctions, or is dropped or damaged in any manner. Return appliance to the nearest Authorized Service Center for examination, repair or electrical or mechanical adjustment.
7. Do not use outdoors.
8. Do not let cord hang over edge of table or counter.
9. Keep hands and utensils out of container while blending to reduce the risk of severe injury to persons or damage to the blender. A scraper may be used but must be used only when the blender is not running.
10. Blades are sharp. Handle carefully.
11. Always operate Blender with cover in place.
12. The use of attachments, including canning jars, not recommended by KitchenAid may cause a risk of injury to persons.
13. When blending hot liquids, remove center piece of two-piece cover.
14. This product is designed for household use only.

SAVE THESE INSTRUCTIONS

Electrical Requirements

Electrical features: 120 VAC, 60 hz,
6 amp

NOTE: Your blender has a 3 prong grounded plug. To reduce the risk of electrical shock, this plug will fit in an outlet only one way. If the plug does not fit in the outlet, contact a qualified electrician. Do not modify the plug in any way.

Do not use an extension cord. If the power supply cord is too short, have a qualified electrician or serviceman install an outlet near the appliance.

⚠ WARNING



Electrical Shock Hazard

Plug into a grounded 3 prong outlet.

Do not remove ground prong.

Do not use an adapter.

Do not use an extension cord.

Failure to follow these instructions can result in death, fire, or electrical shock.

Blender Features

ENGLISH

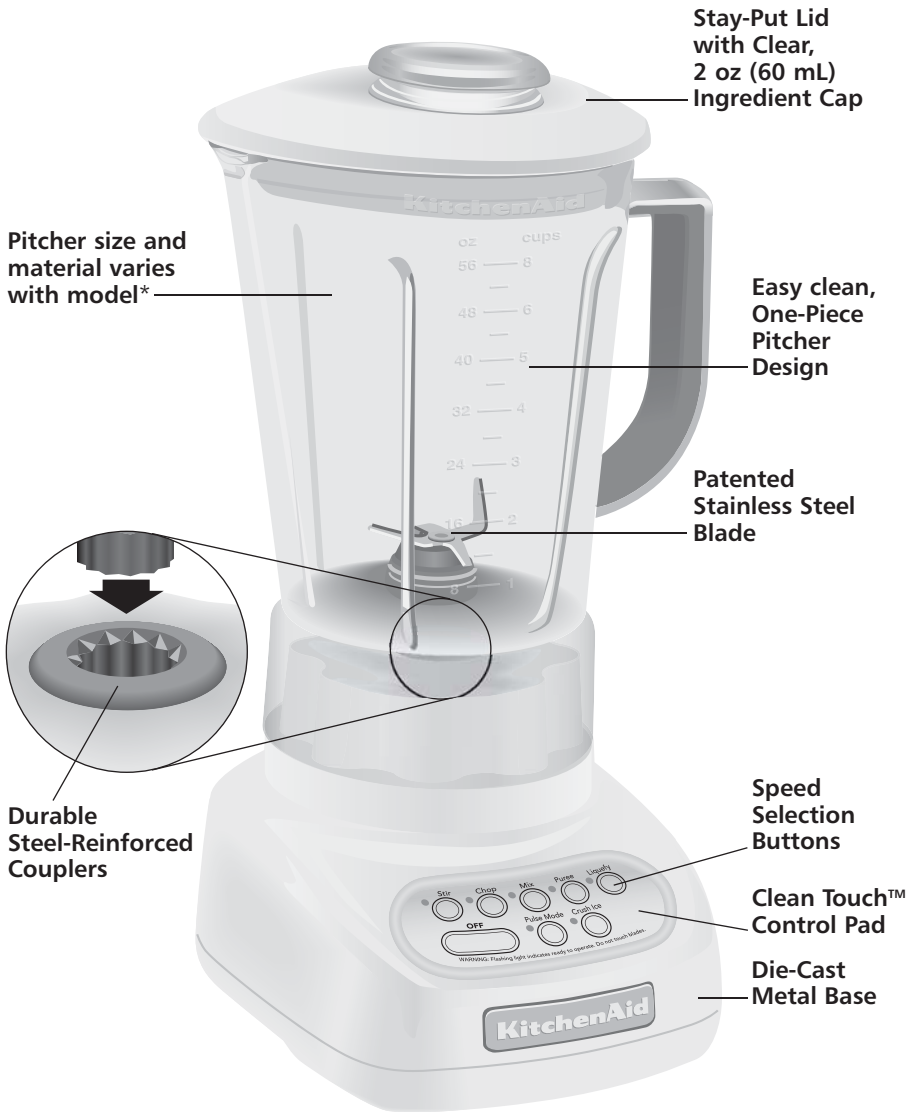

* Model KSB550 48 oz (1.5 L) Glass Pitcher
Models KSB560 and KSB580 56 oz (1.75 L) Polycarbonate Pitcher
Model KSB570 56 oz (1.75 L) Stainless Steel Pitcher

Blender Features

This blender was built and tested to KitchenAid quality standards for optimum performance and long, trouble-free life.

Robust Motor

Rugged 0.9-horsepower motor supplies the power for superb performance with all blending tasks – from pureeing sauces to making chunky salsas, or uniformly crushing a pitcher of ice or frozen fruit within seconds for silky smoothies.

Easy clean, One-Piece Pitcher Design

One-piece design integrates a functional pitcher with dynamic interior contours that continually directs food into the blade for fast, thorough blending. The one-piece design also means cleaning is achieved without removing the blade and other parts. Pitcher stands up to extreme temperatures – from boiling soups to frozen margaritas and has a wide pour spout to ensure smooth pouring. Pitcher is dishwasher safe.

Polycarbonate Pitcher



[Models KSB560 and KSB580]

One-piece 56 oz (1.75 L) capacity clear, polycarbonate pitcher is shatter resistant, scratch resistant, and stain

resistant. Pitcher handle features soft inner-grip for firm, comfortable, no-slip control.

Glass Pitcher



[Model KSB550] Durable 48 oz (1.5 L) one-piece glass pitcher resists scratching, stains, and lingering odors.

Stainless Steel Pitcher



[Model KSB570] Durable 56 oz (1.75 L) one-piece brushed stainless steel pitcher with handle is unbreakable and will stand up to the most

demanding blending tasks.

Patented Stainless Steel Blade

Sharp oversized blade tines are positioned on four different planes for fast, thorough, and consistent blending. Our durable blade design is built into the pitcher for easy handling and cleaning.

Intelli-Speed® Motor Control

Exclusive Intelli-Speed® control automatically works to keep speed constant – even through density changes when ingredients are added. This advanced KitchenAid design maintains an optimal blending speed for each culinary task and control-pad setting.

Speed Selection Buttons

Create frozen drinks and puree sauces or soups in seconds. Blend with confidence, control, and consistency at all speed settings: STIR, CHOP, MIX, PUREE, and LIQUEFY. The PULSE MODE works with all five speeds. The CRUSH ICE mode is designed specifically for crushing ice and will automatically pulse at staggered intervals for optimal results.

Soft Start™ Feature

The blender motor starts at a slower speed to pull food into the blade then quickly increases to selected speed setting. This design feature reduces start-up kick and allows hands-free operation.

Clean Touch™ Control Pad

Wipes clean in an instant. Smooth control pad has no crevices or cracks to trap ingredients.

Durable Steel-Reinforced Couplers

Commercial-quality couplers with 12 interlocking teeth provide direct transfer of motor power to the blade. Pitcher coupler is coated for quiet operation.

Stay-Put Lid with Clear, 2 oz (60 mL) Ingredient Cap

Provides a strong seal. The flexible lid will maintain its tight seal throughout the life of the blender. The lid includes a removable 2 oz (60 mL) cap for convenience in measuring and adding ingredients.

Die-Cast Metal Base

Heavy, die-cast metal base ensures stable, quiet operation when blending a full pitcher of ingredients. Four rubber feet on wide, solid base provide a no-slip, non-marring grip. Smooth and rounded, the base is easy to clean and features tidy cord storage underneath.

Preparing the Blender for Use

Before First Use

Before using your blender for the first time, wipe blender base with a warm sudsy cloth, then wipe clean with a damp cloth. Dry with a soft cloth. Wash one-piece pitcher, lid, and ingredient cap in warm, sudsy water or just add soap and warm water to the pitcher, place it on the blender base, and blend to clean. Rinse parts and wipe dry. See "Care and Cleaning" section.

Blender Assembly

1. Adjust the length of the power cord to suit your needs.



2. Place the one-piece pitcher on the blender base.



⚠ WARNING



Electrical Shock Hazard

Plug into a grounded 3 prong outlet.

Do not remove ground prong.

Do not use an adapter.

Do not use an extension cord.

Failure to follow these instructions can result in death, fire, or electrical shock.

3. Plug into a grounded 3 prong outlet. Blender is now ready for operation.
4. Before removing the pitcher from the base after use, always press OFF and unplug the power cord. If using the Pulse Mode, make sure the blinking red light is off (by pressing OFF) then unplug. Lift the pitcher in a straight, upward motion off of the blender base.

Using the Blender

Before Use

NOTE: While the blender is on or the Pulse Mode indicator light is blinking:

- Do not interfere with blade movement
- Do not remove pitcher lid

Operating the blender

The KitchenAid® blender has 5 speeds: STIR, CHOP, MIX, PUREE, and LIQUEFY. In addition, it also features CRUSH ICE and PULSE MODE.

1. With convenient one-step operation, this unit will operate only when a speed selection button is pressed.

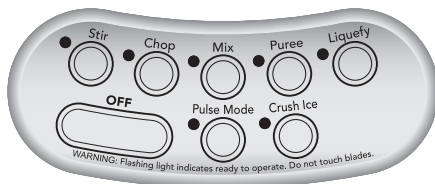

2. Before operating the blender, make sure the pitcher is properly placed on the blender base.
3. Put ingredients in pitcher and firmly attach lid.



4. Press the desired speed button for continuous operation at that speed. The red indicator light by the selected speed will stay lit. You may change settings without stopping the unit by pressing a new speed button.

IMPORTANT: If blending hot foods or liquids, remove the center ingredient cap. Operate only on STIR speed.

5. To turn off the blender, press OFF. The Off button will stop any speed and deactivate the blender at the same time. Before removing the pitcher, press OFF to deactivate the blender, and unplug the power cord.

Crush Ice Feature

Your KitchenAid® blender offers a Crush Ice feature. When selected, the blender will automatically pulse at staggered intervals at the optimal speed for crushing ice or other ingredients.

1. Before operating the blender, make sure the pitcher is properly in place on the blender base.
2. Put ingredients into the pitcher and firmly attach lid.
3. Press CRUSH ICE. The indicator light will stay lit. The blender will automatically pulse at staggered intervals.



4. To turn off the Crush Ice feature, press OFF. The blender is now ready for continuous operation.
5. Before removing the pitcher, press OFF to deactivate the blender, and unplug the power cord.

Using the Blender

Pulse Mode Feature

Your KitchenAid® blender offers Pulse Mode, which allows a “Pulse-at-any-Speed” feature.

NOTE: Pulse Mode will not work with the Crush Ice feature.

1. Before operating the blender, make sure the pitcher is properly in place on the blender base.
2. Put ingredients into pitcher, and firmly attach lid.
3. Press PULSE MODE. The indicator light above the button will blink to indicate that all five speeds are in the Pulse Mode.



4. Select a speed button. Press and hold for the desired length of time. Both the speed button and Pulse Mode indicators will stay lit when pulsing at the selected speed. When button is released, the blending will stop, but the blender will remain in Pulse Mode and the Pulse Mode indicator will return to blinking. To pulse again or at another speed, simply press and hold the button of the desired speed.



5. To turn off the Pulse Mode feature, press OFF. The blender is now ready for continuous operation.
6. Before removing the pitcher, press OFF to deactivate the blender, and unplug the power cord.

Ingredient Cap

The 2 oz (60 mL) ingredient cap can be used to measure and add ingredients. Remove cap and add ingredients at STIR, CHOP or MIX speeds. When operating at higher speeds, with a full pitcher or with hot contents, stop the blender and then add ingredients.



Soft Start™ Blending Feature

The Soft Start™ blending feature automatically starts the blender at a lower speed to draw ingredients into the blades, then quickly increases to the selected speed for optimal performance.

NOTE: The Soft Start™ blending feature only works when a speed is selected from the “Off” mode. The Soft Start™ feature does not work with Pulse Mode or Crush Ice.

Speed Control Guide

Item	Speed	Item	Speed
Blended ice drink	Liquefy	Ice milk-based drink	Liquefy
Cheesecake.	Liquefy	Meat salad for sandwich filling.	Pulse on Chop
Chopped fruits	Pulse on Stir	Mousse.	Liquefy
Chopped vegetables	Pulse on Stir	Oatmeal	Puree
Cream cheese-based spread	Stir	Pancake batter	Mix
Cream soup	Stir	Pesto	Chop
Crushed/chopped Ice	Crush Ice	Pureed fruit/Baby food	Puree
Dip.	Stir	Pureed meat/Baby food meat	Puree
Finely chopped fresh fruits	Crush Ice	Pureed vegetables/Baby food vegetables.	Puree
Finely chopped fresh vegetables	Crush Ice	Salad dressing.	Mix
Fluffy gelatin for pie/desserts	Liquefy	Savory crumb topping	Pulse on Chop
Frozen chopped fruit (defrost slightly until it can be probed with a knife tip)	Crush Ice	Sherbet-based drink	Liquefy
Frozen yogurt-based drink	Liquefy	Smooth ricotta or cottage cheese	Mix
Fruit juice from frozen concentrate	Mix	Streusel topping	Chop
Fruit-based drink.	Liquefy	Sweet crumb topping.	Pulse on Chop
Fruit-based sauce	Stir	Sweet crunch topping.	Pulse on Chop
Grated hard cheese.	Liquefy	Vegetable-based main dish sauce	Stir
Gravy	Mix	Waffle batter	Mix
		White sauce	Stir

TIP: Process up to one standard ice cube tray or 12 to 14 standard ice cubes at a time. Occasional stirring with a spatula will be helpful only when blender is OFF. The Crush Ice feature has been optimized to crush and chop ice without adding any liquid ingredients.

ENGLISH

Care and Cleaning

The blender pitcher and blade can be easily cleaned without disassembly.

- Clean the blender thoroughly after every use.
- Do not immerse the blender base or cord in water.
- Do not use abrasive cleansers or scouring pads.

1. To clean the blade, place the pitcher on the blender base, fill one-half full with warm (not hot) water, and add 1 or 2 drops of dishwashing liquid. Place the lid on the pitcher, press the STIR speed setting, and run the blender for 5 to 10 seconds. Remove the pitcher and empty contents. Rinse the pitcher with

warm water until clean. The pitcher can also be washed in the bottom rack of an automatic dishwasher.

2. To clean the lid and ingredient cap, wash in warm soapy water, then rinse and dry thoroughly. These parts can also be washed in the top rack of an automatic dishwasher. For best results, hand washing is recommended.
3. Wipe the blender base and cord with a warm, sudsy cloth; wipe clean with a damp cloth, and dry with a soft cloth. For storage, the cord can be coiled into the cord-wrap on the bottom of the base.

Troubleshooting

The blender does not operate when a setting is selected:

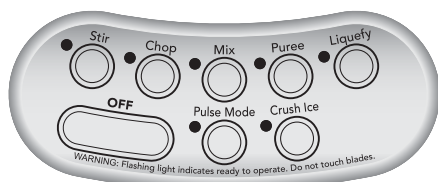

No indicator lights are lit.

Check to see if the blender is plugged into a grounded 3 prong outlet. If it is, press OFF, then unplug the blender. Plug it back in to the same outlet. If the blender still does not work, check the fuse or circuit breaker on the electrical circuit the blender is connected to and make sure the circuit is closed.

The blender stops while blending:

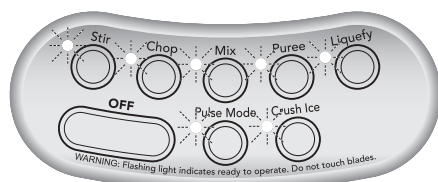

All indicator lights are flashing at the same time.

The blender may be overloaded. If the blender becomes overloaded when blending heavy ingredients, it will automatically shut off to avoid damage to the motor. Press OFF to reset the blender. Remove the jar from the base and divide the jar contents into smaller batches. Adding liquid to the jar may also reduce the load on the blender.

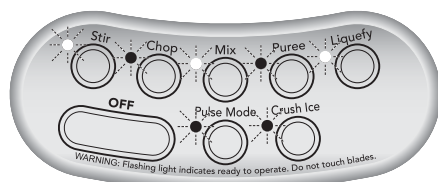

Indicator lights are flashing alternately.

The blender may be jammed. If it's jammed, the blender will stop running to avoid damage to the motor. Press OFF to reset the blender. Remove the pitcher from the base and free the blades by breaking up or removing the contents at the bottom of the jar.

If the problem cannot be fixed with the steps provided in this section, then contact KitchenAid or an authorized service center.

U.S.A./Puerto Rico:

1-800-541-6390

Canada:

1-800-807-6777

Mexico:

01-800-024-17-17 (JV Distribuciones)

01-800-902-31-00 (Industrias Birtman)

See the KitchenAid Warranty and Service section for additional details.

Do not return the blender to the retailer – retailers do not provide service.

Blender Tips

Quick Tips

- In order to produce a smoother texture, blend with CRUSH ICE if you're making beverages using ice.
- Smaller ice cubes can be chopped or crushed faster than large ones.
- Add food to this blender pitcher in larger quantities than you would with other blenders – you can add 2 to 3 cups (475 to 710 mL) at a time versus 1 cup (235 mL) portions.
- For many ingredient mixtures, start the blending process at STIR to thoroughly combine the ingredients. Then increase to a higher speed, if necessary.
- Be sure to keep lid on pitcher while blending.
- If desired, remove center cap of pitcher lid to add liquids or ice cubes while the blender is operating at STIR, CHOP or MIX speeds.
- When operating at higher speeds with a full pitcher or with hot contents, stop the blender and then add ingredients.
- Stop the blender before using utensils in the pitcher. Use a rubber spatula to mix ingredients only when the blender is OFF. Do not use any utensil, including spatulas, in the pitcher while the motor is running.
- Cool hot foods, if possible, before blending. Begin blending warm foods at STIR. Increase to higher speed, if necessary.
- Remove center ingredient cap when blending hot liquids and operate only on STIR. Do not place bare hand on pitcher lid when processing hot liquids.
- Stop and check the consistency of foods after a few seconds to avoid over-processing.

How To ...

Reconstitute frozen juice: For a 6 oz (175 mL) can of orange juice concentrate, combine the juice and correct amount of water in the pitcher. Cover and blend at MIX until thoroughly combined, about 10 to 15 seconds.

For a 12 oz (355 mL) can, combine the juice and 1 can of water in the pitcher. Cover and blend at MIX until thoroughly combined, about 20 to 30 seconds. Stir in remaining 2 cans of water.

Dissolve flavored gelatin: Pour boiling water into the pitcher; add gelatin. Remove center ingredient cap and blend at STIR until gelatin is dissolved, about 10 to 30 seconds. Add other ingredients.

Make cookie and graham cracker crumbs: Break larger cookies into pieces about 1½" (3.75 cm) in diameter. Use smaller cookies as-is. Place in pitcher. In PULSE MODE, cover and blend at CHOP, pulsing a few times, about 3 seconds each time, until desired consistency is reached. Use the crumbs to make a quick topping for frozen yogurt, pudding, or a fruit compote.

To make a finer crumb for pie and dessert crusts, break graham crackers or cookies into pieces about 1½" (3.75 cm) in diameter and place in the pitcher. In PULSE MODE, cover and blend at LIQUEFY, pulsing a few times until desired consistency is reached, about 20 to 30 seconds.

Make cracker crumbs: Follow procedure for cookies. Use as a topping or as an ingredient in main dish casseroles and vegetable dishes.

Make bread crumbs: Tear bread into pieces about 1½" (3.75 cm) in diameter. Follow procedure for cookies. Use as a topping or as an ingredient in main dish casseroles and vegetable dishes.

Blender Tips

Chop fruits and vegetables: Put 2 cups (475 mL) of fruit or vegetable chunks in pitcher. In PULSE MODE, cover and blend at STIR, pulsing a few times, about 2 to 3 seconds each time, until desired consistency is reached.

Puree fruits: Place 2 cups (475 mL) canned or cooked fruit in pitcher. Add 2 to 4 tbs (30 to 60 mL) fruit juice or water per cup (235 mL) of fruit. Cover and blend at PUREE about 5 to 10 seconds.

Puree vegetables: Place 2 cups (475 mL) canned or cooked vegetables in pitcher. Add 2 to 4 tbs (30 to 60 mL) broth, water, or milk per cup (235 mL) of vegetables. Cover and blend at PUREE about 10 to 20 seconds.

Puree meats: Place cooked, cubed, tender meat in pitcher. Add 3 to 4 tbs (45 to 60 mL) broth, water, or milk per cup (235 mL) of meat. Cover and blend on STIR 10 seconds. Stop the blender and scrape sides of pitcher. Cover and blend on PUREE 10 to 20 seconds longer.

Puree cottage cheese or ricotta cheese: Place cottage cheese or ricotta cheese in pitcher. Cover and blend at MIX until smooth, about 25 to 35 seconds. Stop the blender and scrape sides as needed. If necessary, add 1 tbs (15 mL) of skim milk per cup (235 mL) of cottage cheese. Use as a base for low-fat dips and spreads.

Combine liquid ingredients for baked goods: Pour liquid ingredients in pitcher. Cover and blend at LIQUEFY until well-mixed, about 10 to 15 seconds. Pour liquid mixture over dry ingredients and stir well.

Take lumps out of gravy: If sauce or gravy becomes lumpy, place in the pitcher. Cover and blend at MIX until smooth, about 5 to 10 seconds.

Combine flour and liquid for thickening: Place flour and liquid in pitcher. Cover and blend at STIR until smooth, about 5 to 10 seconds.

Prepare white sauce: Place milk, flour, and salt, if desired, in pitcher. Cover, and blend at STIR until well-mixed, about 5 to 10 seconds. Pour into saucepan and cook as usual.

Prepare pancake or waffle batter from mix: Place mix and other ingredients in pitcher. Cover and blend at MIX until well-mixed, 10 to 20 seconds. Stop the blender and scrape sides of the pitcher as needed.

Grate cheese: Cut very cold cheese into $\frac{1}{2}$ to 1" (1.25 to 1.5 cm) cubes. Place up to $\frac{1}{2}$ cup (120 mL) cheese in the pitcher. Cover, and blend at LIQUEFY about 5 to 10 seconds. For hard cheeses, such as Parmesan, bring to room temperature, then blend at LIQUEFY for 10 to 15 seconds.

Make oatmeal for a baby: Place uncooked rolled oats in pitcher. In PULSE MODE, blend at MIX until desired consistency, about 5 pulses, 2 to 3 seconds each pulse. Cook as usual.

Make baby food from adult food: Place prepared adult food in pitcher. Cover and blend at STIR about 10 seconds. Then blend at PUREE about 10 to 30 seconds.

Rinse your blender jar: Fill pitcher one-half full with warm water. Add a few drops of dishwashing liquid. Cover and blend at STIR until sides are clean, about 5 to 10 seconds. Rinse and dry. For complete cleaning, pitcher and lid can also be cleaned in an automatic dishwasher.

Blended Margarita

- $\frac{3}{4}$ cup (175 mL) tequila
- $\frac{1}{2}$ cup (120 mL) orange-flavored liqueur
- $\frac{1}{2}$ cup (120 mL) fresh lime juice
- $\frac{1}{4}$ cup (60 mL) simple syrup or 3 tbs (45 mL) sugar
- 4 cups (945 mL) ice cubes

Simple Syrup

- 1 cup (235 mL) sugar
- 1 cup (235 mL) water

Place ingredients in pitcher. Cover and blend at CRUSH ICE, 15 to 20 pulses, or until slushy.

Yield: 6 servings ($\frac{3}{4}$ cup [175 mL] per serving).

Per Serving: About 118 cal., 0 g protein, 16 g carb, 0 g total fat, 0 g saturated fat, 0 mg cholesterol, 6 mg sodium.

For 56 oz (1.75 L) pitcher:

Place $1\frac{1}{4}$ cups (295 mL) tequila, $\frac{3}{4}$ cup (175 mL) orange-flavored liqueur, $\frac{3}{4}$ cup (175 mL) fresh lime juice, $\frac{1}{3}$ cup (80 mL) simple syrup or 5 tbs (75 mL) sugar, and 5 cups (1.2 L) ice cubes in pitcher. Cover and blend at CRUSH ICE, about 20 pulses, or until slushy.

Yield: 9 servings ($\frac{3}{4}$ cup [175 mL] per serving).

See above for approximate nutrition analysis.

Simple Syrup

In small saucepan, combine sugar and water. Boil until sugar dissolves, 2 to 4 minutes. Cool; cover and refrigerate.

Yield: About $1\frac{1}{4}$ cups (295 mL).

Sparkling Cran-Pineapple Drink

- 1 can (12 oz [355 mL]) frozen cranberry juice cocktail concentrate
- 1 can (8 oz [235 mL]) crushed pineapple, packed in juice and undrained
- 2 cups (475 mL) lemon-lime flavored carbonated beverage, chilled

Place cranberry concentrate and pineapple in pitcher. Cover and blend at LIQUEFY about 10 seconds, or until smooth. Add carbonated beverage. Cover and blend at STIR just until mixed, 2 to 4 seconds.

Yield: 5 servings (about 1 cup [235 mL] per serving).

Per Serving: About 171 cal., 0 g protein, 44 g carb, 0 g total fat, 0 g saturated fat, 0 mg cholesterol, 10 mg sodium.

For 56 oz (1.75 L) pitcher:

Place $1\frac{1}{2}$ cans (12 oz [355 mL] each) frozen cranberry juice cocktail concentrate and $1\frac{1}{2}$ cans (8 oz. [235 mL] each) crushed pineapple (packed in juice and undrained) in pitcher. Cover and blend at LIQUEFY 10 to 15 seconds, or until smooth. Add 3 cups (710 mL) lemon-lime flavored carbonated beverage, chilled. Cover and blend at STIR just until mixed, 2 to 4 seconds.

Yield: 7 servings (about 1 cup [235 mL] per serving).

See above for approximate nutrition analysis.

Strawberry-Banana Smoothie

- 1½ cups (355 mL) buttermilk
- 1 cup (235 mL) frozen unsweetened strawberries
- 1 cup (235 mL) milk
- 3 medium bananas, broken into quarters
- 3 tbs (45 mL) orange marmalade

Place ingredients in pitcher. Cover and blend at LIQUEFY 15 to 20 seconds, or until smooth.

Yield: 5 servings (1 cup [235 mL] per serving).

Per Serving: About 170 cal., 6 g protein, 34 g carb, 2.5 g total fat, 1.5 g saturated fat, 10 mg cholesterol, 90 mg sodium.

For 56 oz (1.75 L) pitcher:

Place 2¼ cups (535 mL) buttermilk, 1¼ cups (295 mL) frozen unsweetened strawberries, 1¼ cups (295 mL) milk, 4 medium bananas (broken into quarters), and ⅓ cup (80 mL) orange marmalade in pitcher. Continue with directions above.

Yield: 7 servings (1 cup [235 mL] per serving).

See above for approximate nutrition analysis.

Rum Mocha

- 2 cups (475 mL) chocolate ice cream
- ½ cup (120 mL) double-strength coffee, cold
- ½ cup (120 mL) dark rum
- 4 ice cubes

Place ingredients in pitcher. Cover and blend at CRUSH ICE, 12 to 15 pulses, or until smooth.

Yield: 4 servings (¾ cup [175 mL] per serving).

Per Serving: About 210 cal., 3 g protein, 19 g carb, 7 g total fat, 4.5 g saturated fat, 20 mg cholesterol, 50 mg sodium.

For 56 oz (1.75 L) pitcher:

Place 4 cups (945 mL) chocolate ice cream, 1 cup (235 mL) double-strength coffee (cold), 1 cup (235 mL) dark rum, and 8 ice cubes in pitcher. Cover and blend at CRUSH ICE, about 20 pulses, or until smooth.

Yield: 8 servings (¾ cup [175 mL] per serving).

See above for approximate nutrition analysis.

Italian Tortellini Tomato Soup

- 2 tbs (30 mL) olive oil
- 1/2 cup (120 mL) chopped onion
- 1/2 cup (120 mL) chopped green pepper
- 2 cans (14.5 oz [429 mL] each) Italian-seasoned diced tomatoes, undrained
- 1 tbs (15 mL) sugar
- 1/2 tsp (2 mL) salt
- 1/4 tsp (1 mL) fennel seed
- 1/8 tsp (0.5 mL) cayenne pepper
- 1 can (14 oz. [415 mL]) beef broth
- 1 package (9 oz [265 mL]) refrigerated cheese-filled tortellini
- Shredded mozzarella cheese, if desired
- Chopped fresh parsley, if desired

In large saucepan over medium-high heat, heat olive oil. Add onion and green pepper; cook 3 to 5 minutes, or until limp. Add tomatoes, sugar, salt, fennel seed, and cayenne pepper. Reduce heat to low; simmer, uncovered, 15 to 20 minutes, or until thickened, stirring occasionally. Cool 5 minutes.

Pour half of cooled tomato mixture into pitcher. Cover and blend at STIR about 15 seconds. Add remaining tomato mixture. Cover and blend at STIR about 15 seconds. Blend at LIQUEFY about 10 seconds, or until smooth.

Return mixture to saucepan. Add broth. Bring to a boil. Add tortellini. Reduce heat to low; simmer, uncovered, 8 to 10 minutes, or until tortellini is tender, stirring occasionally.

Serve hot, sprinkled with mozzarella cheese and chopped parsley, if desired.

Yield: 6 (1 cup [235 mL]) servings.

Per Serving: About 250 cal., 8 g protein, 35 g carb, 8 g total fat, 2.5 g saturated fat, 20 mg cholesterol, 1,100 mg sod.

For 56 oz (1.75 L) pitcher:

Heat 3 tbs (45 mL) olive oil in large Dutch oven over medium-high heat. Add 3/4 cup (175 mL) chopped onion and 3/4 cup (175 mL) chopped green pepper; cook 3 to 5 minutes, or until limp. Add 3 cans (14.5 oz [429 mL] each) Italian-seasoned diced tomatoes (undrained), 1 1/2 tbs (20 mL) sugar, 3/4 tsp (4 mL) salt, 1/4 tsp (1 mL) fennel seed, and 1/4 tsp (1 mL) cayenne pepper. Reduce heat to low; simmer, uncovered, 20 to 25 minutes, or until thickened, stirring occasionally. Cool 5 minutes.

Pour half of cooled tomato mixture into pitcher. Cover and blend at STIR about 15 seconds. Add remaining tomato mixture. Cover and blend at STIR about 15 seconds. Blend at LIQUEFY 10 to 15 seconds, or until smooth.

Return mixture to Dutch oven. Add 1 1/2 cans (14 oz [415 mL] each) beef broth. Bring to a boil. Add 1 1/2 packages (9 oz [265 mL] each) refrigerated cheese-filled tortellini. Continue with directions above.

Yield: 9 (1 cup [235 mL]) servings.

See above for approximate nutrition analysis.

Blueberry Pancakes and Sauce

Sauce

- 1/4 cup (60 mL) sugar*
- 2 tsps (10 mL) cornstarch*
- 2/3 cup (160 mL) water*
- 1/2 tsp (2 mL) grated lemon peel*
- 2 cups (475 mL) fresh or frozen blueberries (do not thaw)*

Place sauce ingredients in saucepan. Cook over medium heat until mixture thickens, stirring constantly. Cool 5 minutes. Pour mixture into pitcher. Cover and blend at STIR about 5 seconds; scrape sides of pitcher if necessary. Blend at MIX about 10 seconds, or until smooth. Pour into serving container. Rinse pitcher.

Place eggs in pitcher. Cover and blend at STIR about 5 seconds. Add buttermilk, oil, and lemon peel. Blend at MIX about 5 seconds. Add flour, sugar, baking powder, baking soda, salt, and nutmeg. Using PULSE feature, blend at MIX, pulsing 5 times, 2 to 3 seconds each time, or just until dry ingredients are moistened. By hand, gently stir in blueberries.

Pancakes

- 2 eggs*
- 2 cups (475 mL) buttermilk*
- 2 tbs (30 mL) vegetable oil*
- 1/2 tsp (2 mL) grated lemon peel*
- 2 1/4 cups (535 mL) all-purpose flour*
- 2 tbs (30 mL) sugar*
- 1 tsp (5 mL) baking powder*
- 1 tsp (5 mL) baking soda*
- 1/2 tsp (2 mL) salt*
- 1/4 tsp (1 mL) nutmeg*
- 1 cup (235 mL) fresh or frozen blueberries (do not thaw)*

Heat nonstick griddle to medium-high, greasing griddle if it is not nonstick. Pour scant $\frac{1}{4}$ cup (60 mL) batter for each pancake onto griddle, stirring batter occasionally to distribute blueberries. Cook until bubbles form on surface and edges become dry, 1 to 2 minutes. Turn; cook until golden brown on underside, 1 to 2 minutes. Serve with warm blueberry sauce.

Yield: About 8 servings (2, 4" [10 cm] pancakes and $\frac{1}{4}$ cup [60 mL] sauce per serving).

Per Serving: About 280 cal., 8 g protein, 48 g carb, 6 g total fat, 1 g saturated fat, 55 mg cholesterol, 280 mg sodium.

For 56 oz (1.75 L) pitcher:

Place $\frac{1}{3}$ cup (80 mL) sugar, 1 tbs (15 mL) cornstarch, 1 cup (235 mL) water, $\frac{3}{4}$ tsp (4 mL) grated lemon peel, and 3 cups (710 mL) fresh or frozen blueberries (do not thaw) in saucepan. Cook over medium heat until mixture thickens, stirring constantly. Cool 5 minutes. Pour mixture into pitcher. Cover and blend at STIR about 5 seconds; scrape sides of pitcher if necessary. Blend at MIX about 10 seconds, or until smooth. Pour into serving container. Rinse pitcher.

Place 3 eggs in pitcher. Cover and blend at STIR about 5 seconds. Add 3 cups (710 mL) buttermilk, 3 tbs (45 mL) oil, and $\frac{3}{4}$ tsp (4 mL) grated lemon peel. Blend at MIX about 5 seconds. Add $3\frac{1}{3}$ cups (790 mL) all-purpose flour, 3 tbs (45 mL) sugar, $1\frac{1}{2}$ tsps (7 mL) baking powder, $1\frac{1}{2}$ tsps (7 mL) baking soda, $\frac{3}{4}$ tsp (4 mL) salt, and $\frac{1}{4}$ tsp (1 mL) nutmeg. Using PULSE feature, blend at MIX, pulsing 6 times, 2 to 3 seconds each time, or just until dry ingredients are moistened. By hand, gently stir in $1\frac{1}{2}$ cups (355 mL) fresh or frozen blueberries (do not thaw). Continue with directions above.

Yield: about 12 servings (2, 4" [10 cm] pancakes and $\frac{1}{4}$ cup [60 mL] sauce per serving).

See above for approximate nutrition analysis.

Raspberry Vinaigrette Dressing

- 1 cup (235 mL) fresh or frozen raspberries, thawed
- 2 tbs (30 mL) sugar
- 3 tbs (45 mL) raspberry vinegar
- 2 tbs (30 mL) vegetable oil

Place ingredients in pitcher. Cover and blend at STIR about 15 seconds; scrape sides of pitcher if necessary. Blend at LIQUEFY 10 to 15 seconds, or until smooth. Serve over tossed green salads or fruit salads. Store in refrigerator.

Yield: 6 servings (2 tbs [10 mL] per serving).

Per Serving: About 70 cal., 0 g protein, 7 g carb, 4.5 g total fat, 0 g saturated fat, 0 mg cholesterol, 0 mg sodium.

For 56 oz (1.75 L) pitcher:

Place 2 cups (475 mL) fresh or frozen raspberries (thawed), $\frac{1}{4}$ cup (60 mL) sugar, $\frac{1}{3}$ cup (80 mL) raspberry vinegar, and $\frac{1}{4}$ cup (60 mL) vegetable oil in pitcher. Continue with directions above.

Yield: 12 servings (2 tbs [30 mL] per serving).

See above for approximate nutrition analysis.

Chocolate Pot De Crème

- 1 cup (235 mL) semisweet chocolate chips
- $\frac{1}{4}$ cup (60 mL) egg substitute or 1 pasteurized egg, beaten
- $\frac{1}{2}$ tsp (2 mL) vanilla
- $\frac{3}{4}$ cup (175 mL) half-and-half
Sweetened whipped cream or whipped topping, if desired

Place chocolate chips, egg substitute, and vanilla in pitcher. Heat half-and-half until bubbles form around edge. Pour over chocolate chips. Cover and blend at LIQUEFY 20 to 25 seconds, or until chocolate chips are melted and mixture is smooth; scrape sides of pitcher if necessary.

Pour into small cups. Refrigerate until set, 4 to 6 hours. Serve with whipped cream, if desired.

Yield: 4 servings ($\frac{1}{2}$ cup [120 mL] per serving).

Per Serving: About 350 cal., 7 g protein, 38 g carb, 22 g total fat, 13 g saturated fat, 15 mg cholesterol, 45 mg sodium.

For 56 oz (1.75 L) pitcher:

Place 1 package (12 oz. [340 g]) semisweet chocolate chips, $\frac{1}{2}$ cup (120 mL) egg substitute or 2 pasteurized eggs (beaten), and 1 tsp (5 mL) vanilla in pitcher. Using $1\frac{1}{2}$ cups (355 mL) half-and-half, continue with directions above.

Yield: 8 servings ($\frac{1}{2}$ cup [120 mL] per serving).

See above for approximate nutrition analysis.

Fresh Fruit Milk Shake

- 2 cups (475 mL) milk
- 1½ cups (355 mL) vanilla ice cream
- 3 cups (710 mL) fresh sliced peaches, strawberries or other favorite fruit*
- 2 tbs (30 mL) powdered sugar, if desired

Place ingredients in pitcher. Cover and blend at LIQUEFY 10 to 15 seconds, or until smooth.

Yield: 5 servings (about 1 cup [235 mL] per serving).

*Three cups (710 mL) frozen, slightly thawed favorite fruit may be used instead.

Per Serving: About 170 cal., 6 g protein, 24 g carb, 7 g total fat, 4 g saturated fat, 25 mg cholesterol, 70 mg sodium.

For 56 oz (1.75 L) pitcher:

Place 2½ cups (590 mL) milk, 2 cups (475 mL) vanilla ice cream, 4 cups (945 mL) fresh sliced peaches, strawberries or other favorite fruit, and 3 tbs (45 mL) powdered sugar (if desired) in pitcher. Continue with directions above.

Yield: 7 servings (about 1 cup [235 mL] per serving).

See above for approximate nutrition analysis.

KitchenAid® Blender Warranty

ENGLISH

Length of Warranty:	KitchenAid Will Pay For:	KitchenAid Will Not Pay For:
<p>50 United States, the District of Columbia, Canada, and Puerto Rico: One-year limited warranty from date of purchase.</p>	<p>50 United States, the District of Columbia and Canada: Hassle-free replacement of your blender. See the following page for details on how to arrange for replacement. OR In Puerto Rico: The replacement parts and repair labor costs to correct defects in materials and workmanship. Service must be provided by an Authorized KitchenAid Service Center. To arrange for service, see the following pages.</p>	<p>A. Repairs when blender is used in other than normal single family home use. B. Damage resulting from accident, alteration, misuse or abuse or use with products not approved by KitchenAid. C. Replacement parts or repair labor costs for blender when operated outside the country of purchase.</p>

DISCLAIMER OF IMPLIED WARRANTIES; LIMITATION OF REMEDIES IMPLIED WARRANTIES, INCLUDING TO THE EXTENT APPLICABLE WARRANTIES OF MERCHANTABILITY OR FITNESS FOR A PARTICULAR PURPOSE, ARE EXCLUDED TO THE EXTENT LEGALLY PERMISSIBLE. ANY IMPLIED WARRANTIES THAT MAY BE IMPOSED BY LAW ARE LIMITED TO ONE YEAR, OR THE SHORTEST PERIOD ALLOWED BY LAW. SOME STATES AND PROVINCES DO NOT ALLOW LIMITATIONS OR EXCLUSIONS ON HOW LONG AN IMPLIED WARRANTY OF MERCHANTABILITY OR FITNESS LASTS, SO THE ABOVE LIMITATIONS OR EXCLUSIONS MAY NOT APPLY TO YOU.

IF THIS PRODUCT FAILS TO WORK AS WARRANTED, CUSTOMER'S SOLE AND EXCLUSIVE REMEDY SHALL BE REPAIR OR REPLACEMENT ACCORDING TO THE TERMS OF THIS LIMITED WARRANTY. KITCHENAID AND KITCHENAID CANADA DO NOT ASSUME ANY RESPONSIBILITY FOR INCIDENTAL OR CONSEQUENTIAL DAMAGES. This warranty gives you specific legal rights and you may also have other rights which vary from state to state or province to province.

Hassle-Free Replacement Warranty – 50 United States and District of Columbia

We're so confident the quality of our products meets the exacting standards of KitchenAid that, if your blender should fail within the first year of ownership, KitchenAid will arrange to deliver an identical or comparable replacement to your door free of charge and arrange to have your original blender returned to us. Your replacement unit will also be covered by our one year limited warranty. Please follow these instructions to receive this quality service.

If your KitchenAid® blender should fail within the first year of ownership, simply call our toll-free Customer Satisfaction Center at 1-800-541-6390 Monday through Friday, 8 a.m. to 8 p.m. (Eastern Time), or Saturday, 10 a.m. to 5 p.m. Give the consultant your complete shipping address. (No P.O. Box numbers, please.)

When you receive your replacement blender, use the carton and packing materials to pack up your original blender. In the carton, include your name and address on a sheet of paper along with a copy of the proof of purchase (register receipt, credit card slip, etc.).

Hassle-Free Replacement Warranty – Canada

We're so confident the quality of our products meets the exacting standards of the KitchenAid® brand that, if your blender should fail within the first year of ownership, KitchenAid Canada will replace your blender with an identical or comparable replacement. Your replacement unit will also be covered by our one year limited warranty. Please follow these instructions to receive this quality service.

If your KitchenAid® blender should fail within the first year of ownership, take the blender or ship collect to an Authorized KitchenAid Service Centre. In the carton include your name and complete shipping address along with a copy of the proof of purchase (register receipt, credit card slip, etc.). Your replacement blender will be returned prepaid and insured. If you are unable to obtain satisfactory service in this manner call our toll-free Customer eXperience Centre at 1-800-807-6777. Or write to us at:

Customer eXperience Centre
KitchenAid Canada
1901 Minnesota Court
Mississauga, ON L5N 3A7

How To Arrange for Warranty Service in Puerto Rico

Your KitchenAid® blender is covered by a one-year limited warranty from the date of purchase. KitchenAid will pay for replacement parts and labor costs to correct defects in materials and workmanship. Service must be provided by an Authorized KitchenAid Service Center.

Take the blender or ship prepaid and insured to an Authorized KitchenAid Service Center. Your repaired Blender will be returned prepaid and insured. If you are unable to obtain satisfactory service in this manner, call toll-free 1-800-541-6390 to learn the location of a Service Center near you.

How To Arrange for Service after the Warranty Expires – All Locations

Before calling for service, please review the "Troubleshooting" section.

For service information in the 50 United States, District of Columbia, and Puerto Rico,
call toll-free **1-800-541-6390**.

Or write to:
Customer Satisfaction Center
KitchenAid Portable Appliances
P.O. Box 218
St. Joseph, MI 49085-0218

Or contact an Authorized Service Center near you.

For service information in Canada,
call toll-free **1-800-807-6777**.

Or write to:
Customer eXperience Centre
KitchenAid Canada
1901 Minnesota Court
Mississauga, ON L5N 3A7

ENGLISH

How To Arrange for Service Outside these Locations

Consult your local KitchenAid dealer or the store where you purchased the blender for information on how to obtain service.

For service information in Mexico,
call toll-free

01-800-024-17-17
(JV Distribuciones)

Or

01-800-902-31-00
(Industrias Birtman)

How To Order Accessories and Replacement Parts

To order accessories or replacement parts for your blender in the 50 United States, District of Columbia, and Puerto Rico,
call toll-free **1-800-541-6390** Monday through Friday, 8 a.m. to 8 p.m. (Eastern Time), or Saturday, 10 a.m. to 5 p.m.

Or write to:
Customer Satisfaction Center,
KitchenAid Portable Appliances,
P.O. Box 218,
St. Joseph, MI 49085-0218

To order accessories or replacement parts for your blender in Canada,
call toll-free **1-800-807-6777**.

Or write to:
Customer eXperience Centre
KitchenAid Canada
1901 Minnesota Court
Mississauga, ON L5N 3A7

To order accessories or replacement parts for your blender in Mexico,
call toll-free

01-800-024-17-17
(JV Distribuciones)

Or

01-800-902-31-00
(Industrias Birtman)

® Registered trademark/Marque déposée/Marca registrada de KitchenAid, U.S.A.

™ Trademark/Marque de commerce/Marca de comercio de KitchenAid, U.S.A.,
KitchenAid Canada licensee in Canada/Emploi licencié par KitchenAid Canada au Canada/
Usada en Canadá bajo licencia de KitchenAid Canada.

© 2009. All rights reserved. Tout droits réservés. Todos los derechos reservados.

9709225B



3/09

BIEN PENSÉ. BIEN FABRIQUÉ.™

PARTS LIST

for

KitchenAid®

5-SPEED MIDLINE BLENDER 56 OZ. PLASTIC JAR

MODELS:

**KSB580NK0 (Nickel)
KSB580CR0 (Chrome)**



**FOR CUSTOMER SATISFACTION ALWAYS USE
FACTORY SPECIFICATION PARTS**



UNIT PARTS

FOR VARIATIONS OF MODEL: KSB580__0

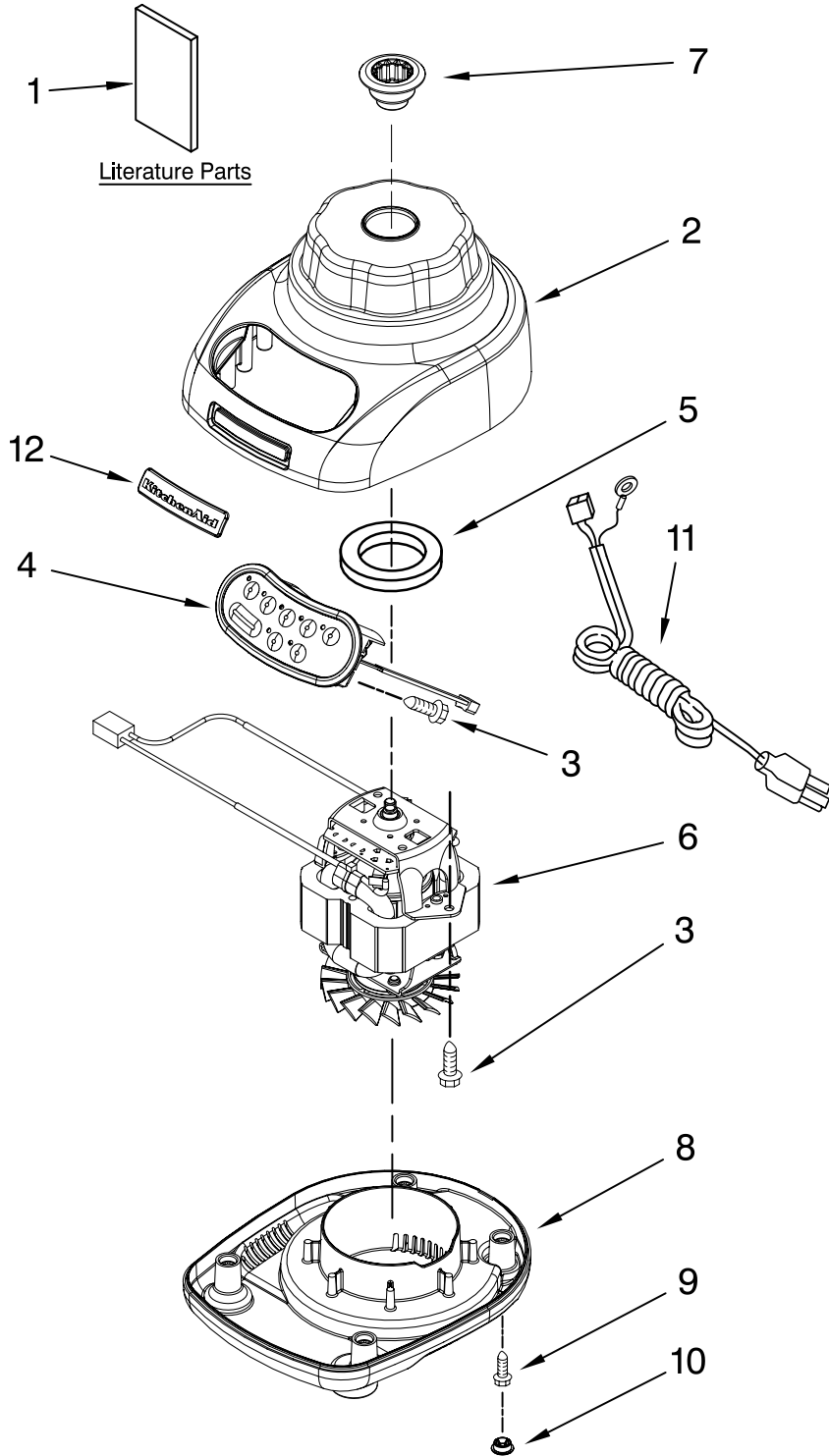

Illus. No.	Part No.	DESCRIPTION
1		Literature Parts
	9709225	Use & Care Guide
	8212257	Repair Parts List
2		Housing, Upper
	9709257	Nickel
	9709500	Chrome
3	303921	Screw
4	9709339	Control Assembly (Incl. Overlay)
5	9709366	Seal, Motor
6	9708887	Motor, 120V, 5sp
7	9708914	Coupling, Drive
8		Base
	9708937	Black
9	8533931	Screw
10	9708927	Foot, Rubber
11		Power Cord
	9708928	Black
12	9708916	Nameplate

FOR ORDERING INFORMATION REFER TO PARTS PRICE LIST

ATTACHMENT PARTS

FOR VARIATIONS OF MODEL: KSB580__0

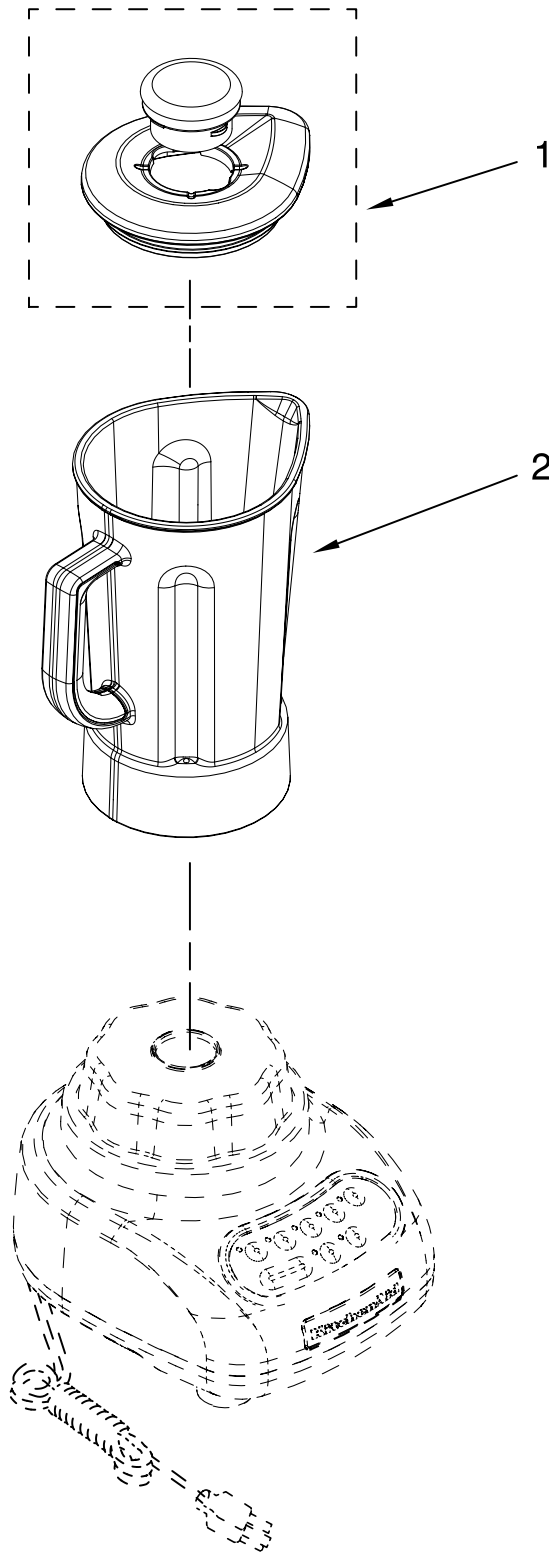

Illus. No.	Part No.	DESCRIPTION
1		Lid Assembly (Includes Cap)
	9709363	Onyx Black
2	9708904	Jar Assembly (Incl Blade Assy)

FOR ORDERING INFORMATION REFER TO PARTS PRICE LIST

Free Manuals Download Website

<http://myh66.com>

<http://usermanuals.us>

<http://www.somanuals.com>

<http://www.4manuals.cc>

<http://www.manual-lib.com>

<http://www.404manual.com>

<http://www.luxmanual.com>

<http://aubethermostatmanual.com>

Golf course search by state

<http://golfingnear.com>

Email search by domain

<http://emailbydomain.com>

Auto manuals search

<http://auto.somanuals.com>

TV manuals search

<http://tv.somanuals.com>