WARMING DRAWER

Use & Care Guide

For questions about features, operation/performance, parts, accessories or service, call: **1-800-422-1230** or visit our website at...
www.kitchenaid.com

Table of Contents2



TABLE OF CONTENTS

WARMING DRAWER SAFETY	3
PARTS AND FEATURES.....	4
BEFORE USING YOUR WARMING DRAWER.....	5
Electrical Requirements	5
USING YOUR WARMING DRAWER.....	5
Setting the Controls	5
Positioning Racks and Pans	6
How to Use	7
Warming Serving Bowls and Plates	7
Raising (Proofing) Bread	8
Using Aluminum Foil	8
CARING FOR YOUR WARMING DRAWER	8
Drawer Slides	8
Removing the Drawer	8
Replacing the Drawer.....	9
Cleaning the Drawer.....	9
TROUBLESHOOTING.....	10
ASSISTANCE OR SERVICE	10
WARRANTY	12

WARMING DRAWER SAFETY

Your safety and the safety of others is very important.

We have provided many important safety messages in this manual and on your appliance. Always read and obey all safety messages.



This is the safety alert symbol.

This symbol alerts you to hazards that can kill or hurt you and others.

All safety messages will be preceded by the safety alert symbol and the word "DANGER" or "WARNING." These words mean:

 **DANGER**

You will be killed or seriously injured if you don't follow instructions.

 **WARNING**

You can be killed or seriously injured if you don't follow instructions.

All safety messages will identify the hazard, tell you how to reduce the chance of injury, and tell you what can happen if the instructions are not followed.

IMPORTANT SAFETY INSTRUCTIONS

WARNING: To reduce the risk of fire, electrical shock, injury to persons, or damage when using the warming drawer, follow basic precautions, including the following:

- Proper Installation – Be sure the warming drawer is properly installed and grounded by a qualified technician.
- Never Use the Warming Drawer for Warming or Heating the Room.
- Do Not Leave Children Alone – Children should not be left alone or unattended in area where warming drawer is in use. They should never be allowed to sit or stand on any part of the warming drawer.
- Wear Proper Apparel – Loose-fitting or hanging garments should never be worn while using the warming drawer.
- User Servicing – Do not repair or replace any part of the warming drawer unless specifically recommended in the manual. All other servicing should be referred to a qualified technician.
- Storage in Warming Drawer – Flammable materials should not be stored in a warming drawer.
- Do Not Use Water on Grease Fires – Smother fire or flame or use dry chemical or foam-type extinguisher.
- Use Only Dry Potholders – Moist or damp potholders on hot surfaces may result in burns from steam. Do not let potholder touch hot heating elements. Do not use a towel or other bulky cloth.
- Use Care When Opening Door – Let hot air or steam escape before removing or replacing food.
- Do Not Heat Unopened Food Containers – Build-up of pressure may cause container to burst and result in injury.
- Placement of Warming Drawer Racks – Always place warming drawer racks in desired location while warming drawer is cool. If rack must be moved while warming drawer is hot, do not let potholder contact hot heating element in warming drawer.
- DO NOT TOUCH HEATING ELEMENTS OR INTERIOR SURFACES OF WARMING DRAWER – Heating elements may be hot even though they are dark in color. Interior surfaces of a warming drawer become hot enough to cause burns. During and after use, do not touch, or let clothing or other flammable materials contact heating elements or interior surfaces of warming drawer until they have had sufficient time to cool. Other surfaces of the warming drawer may become hot enough to cause burns – among these surfaces are warming drawer vent openings and surfaces near these openings and warming drawer doors.

SAVE THESE INSTRUCTIONS

PARTS AND FEATURES

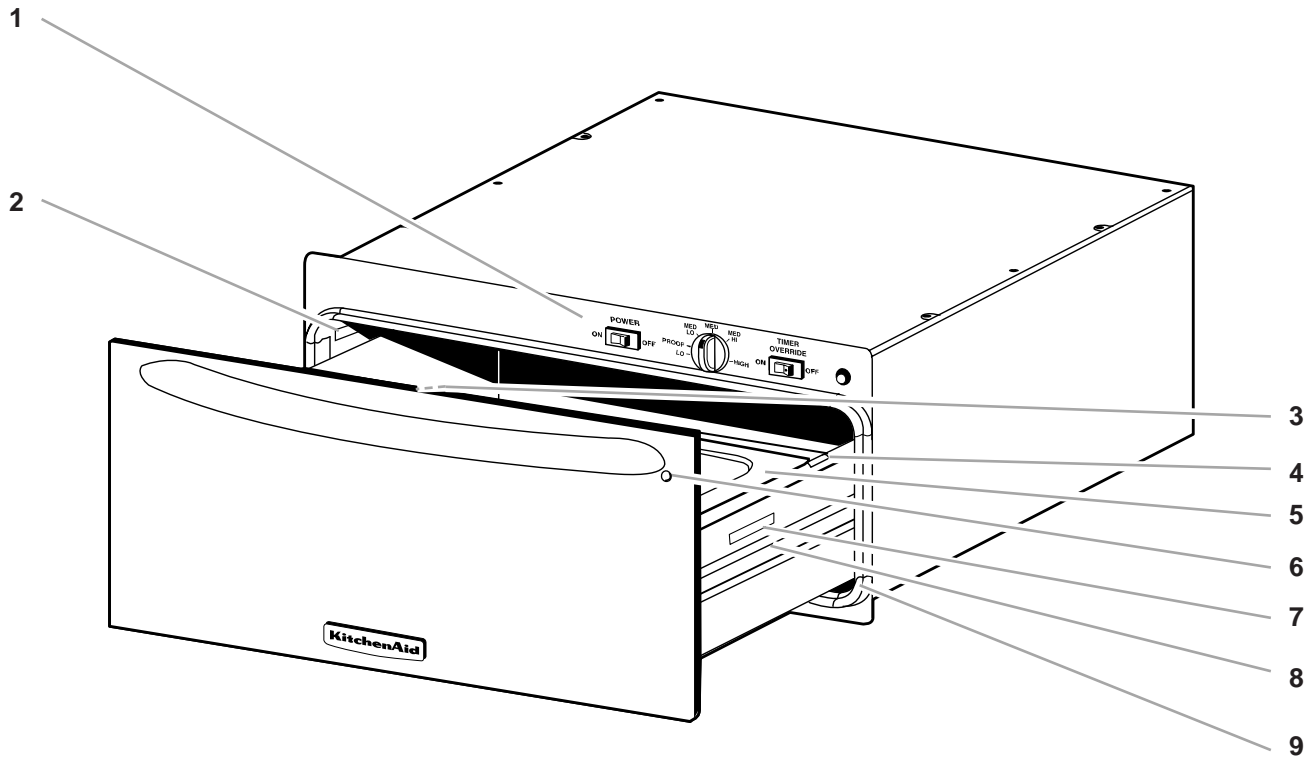

- | | | |
|----------------------------------|----------------------------|--------------------------------|
| 1. Control Panel | 4. Pan Support and Locator | 7. Consumer Information Number |
| 2. Model and Serial Number Plate | 5. Pans | 8. Drawer Slide |
| 3. Moist-Dry Slide (not shown) | 6. "ON" Light Viewer | 9. Gasket |

Control Panel

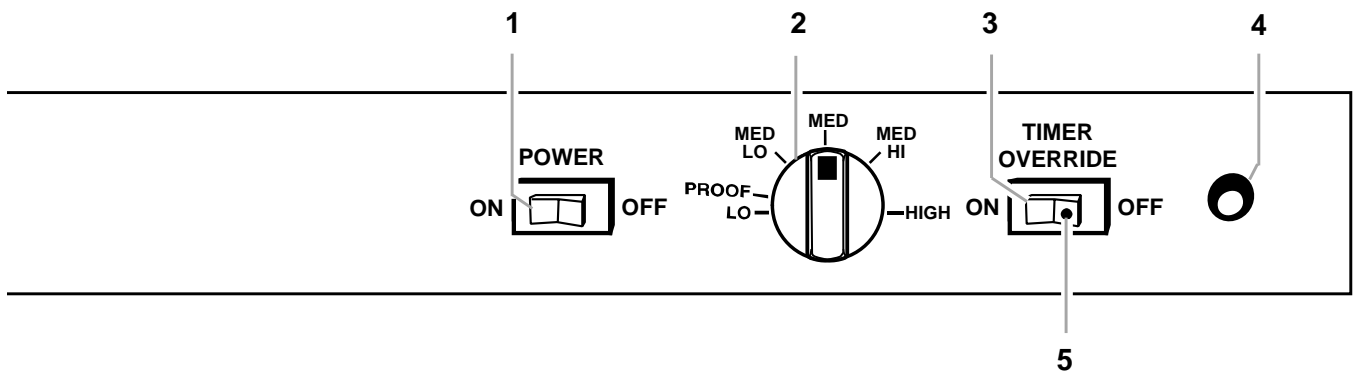

- | | | |
|-----------------------------|-------------------------------|-------------------------|
| 1. Power "ON" Switch | 3. Timer Override Switch | 5. Timer Override Light |
| 2. Temperature Control Knob | 4. Power "ON" Indicator Light | |

BEFORE USING YOUR WARMING DRAWER

Electrical Requirements

⚠️ WARNING



Electrical Shock Hazard

Plug into a grounded 3 prong outlet.

Do not remove ground prong.

Do not use an adapter.

Do not use an extension cord.

Failure to follow these instructions can result in death, fire, or electrical shock.

It is important to make sure you have the proper electrical connection:

A 115 Volt, 60 Hz., AC only 15 or 20 amperes electrical supply, properly grounded in accordance with the National Electrical Code and local codes and ordinances, is required.

It is recommended that a separate circuit, serving only your warming drawer, be provided.

Recommended grounding method

For your personal safety, this appliance must be grounded. This appliance is equipped with a power supply cord having a 3 prong grounding plug. To minimize possible shock hazard, the cord must be plugged into a mating, 3 prong, grounding-type wall receptacle, grounded in accordance with the National Electrical Code and local codes and ordinances. If a mating wall receptacle is not available, it is the personal responsibility of the customer to have a properly grounded, 3 prong wall receptacle installed by a qualified electrician.

USING YOUR WARMING DRAWER

Setting the Controls

⚠️ WARNING

Food Poisoning Hazard

Do not let food sit for more than one hour before or after cooking.

Doing so can result in food poisoning or sickness.

Power "ON" switch

Press the Power "ON" switch to turn the unit on.

Power "ON" Indicator light

The Indicator light is located on the right side of the Timer Override switch. Once the power is turned on, the red indicator light will illuminate. When the unit is turned off automatically or manually, the Indicator light will go out and the drawer will begin to cool.

Temperature control knob

The temperature is controlled by rotating the control knob to the desired setting. The temperature ranges from approximately 90° F (Lo) to 225° F (Hi).

Timer

The Warming Drawer has an automatic 4 hour timer. After 4 hours, the unit will shut off. Although the automatic timer is set for a 4 hour period, do not leave any food items in the Warming Drawer for more than one hour. Bacterial growth may occur.

NOTE: The Timer can be turned off using the Timer Override switch.

Timer Override switch

The Timer Override switch allows you to run the unit past 4 hours, until it is turned off manually with the Power switch. It is recommended that the switch be left in the OFF position, unless longer warming times are required. When the Override switch is in the ON position, the light on the switch will illuminate to notify that the Timer has been bypassed.

IMPORTANT: Although the Timer can be bypassed by using the Timer Override switch, never allow food items to remain in the Warming Drawer longer than one hour. Bacterial growth may occur.

Moist-Dry slide.

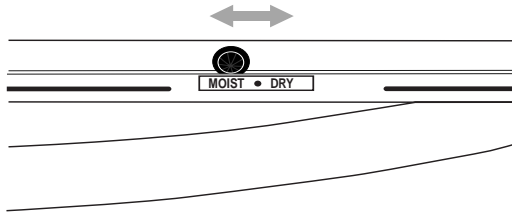

The Moist-Dry slide allows you to open or close the vent slots in the door. The MOIST setting holds the moisture in. The DRY setting allows steam/moisture to escape from the drawer.

- **To keep foods moist**, put slide on MOIST, closing vents. Closing the vents seals the drawer, keeping hot food soft and moist.

NOTE: Condensation may form on inner surfaces.

- **To keep foods crisp**, put slide on DRY, opening vents. With the vents open the moisture is released from the drawer, keeping hot food crisp.

Positioning Racks and Pans

Dual level rack

The rack accompanying your drawer can be used in two different positions, high and low.

Low position

raises the utensil ½ inch from bottom of drawer.

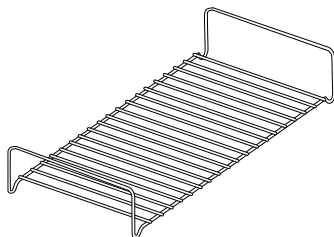

High position

lets you stack items in the drawer.

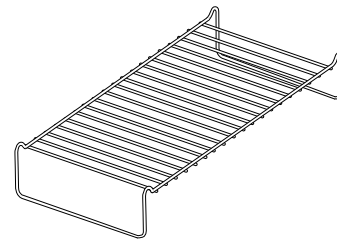

To stack items:

- Rack will fit from front to back or side to side.

NOTE: When placing front to back, drawer must be fully open.

- It may be necessary to cover some foods and use a higher temperature setting with larger loads.
- To warm both cooked foods and empty serving dishes at the same time, place the serving dishes on the drawer bottom during preheat and the food on the high rack position after preheat.
- Foods contained in heat-safe glass or glass ceramic utensils may require a higher temperature setting than food contained in metal utensils.
- Extra time should be allotted for the drawer temperature to stabilize, when adding items or checking food.

Pans

- The pans provided can withstand oven temperatures and are approved for oven cooking.
- If not cooking in pan, warm pans during preheat time. Food temperature will fall below recommended levels if pan is not warm.
- Ensure pan support is properly installed in locator notch before inserting pans.

30" shown (27" not shown)

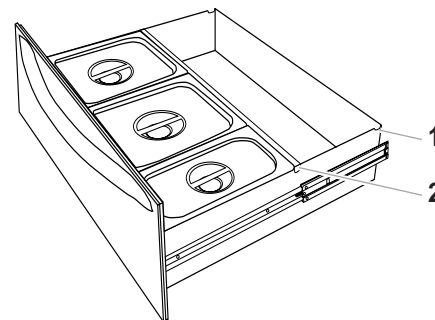

1. Storage notch
2. Locator pan support

NOTE: 27" model comes with only 2 pans.

- When not using pans, place locator pan support in storage notch.

How to Use

The Warming Drawer is intended to hold hot foods warm after cooking and is not intended for cooking foods.

1. Press the Power "ON" switch to turn the unit on.
2. Select MOIST or DRY setting.
3. Set drawer to desired temperature setting (example: LO, MED LO, MED, MED HI, HI).
4. Allow drawer to preheat:
 - LO- 5 minutes
 - MED- 8 minutes
 - HI- 10 minutes
 - Preheat with rack and/or pans in desired position, if using accessories.
 - Preheat empty serving dishes when preheating drawer.
5. Place hot cooked food in cooking utensil or heat-safe serving dish/container. Place food in drawer.
 - Aluminum foil can be used to cover food.
 - Do not use plastic wrap to cover foods.

Temperature control chart

You can set the drawer temperature anywhere between LO--HI. When keeping several foods hot, set the drawer to the food requiring the highest temperature setting. Place item(s) requiring the highest temperature on the rack and those items requiring the lowest temperature on the bottom of the drawer.

Cover suggested for foods listed below (■)

Food	Heat and Vent Settings	Pan usage or rack position
Bacon	MED HI - MOIST	pan
Beef, medium and well done	MED HI - MOIST	low rack
Bread, hard rolls	MED - DRY	low rack
■ Bread, soft rolls	MED - MOIST	low rack
Casseroles	MED - MOIST	high rack
■ Casseroles	MED HI - MOIST	low rack

Food	Heat and Vent Settings	Pan usage or rack position
Coffee cake	MED - MOIST	low rack
■ Cooked cereal	MED HI - MOIST	low rack
■ Eggs	HI - MOIST	pan
Fish, seafood (breaded)	HI - MOIST	low rack
■ (no breading)		
■ Fried foods	Hi - MOIST	pan
■ Gravy, cream sauces	HI - MOIST	low rack
Ham	MED HI - MOIST	low rack
Hors d'oeuvres (crisp)	HI - MOIST	pan
■ (soft)		
Lamb	MED HI - MOIST	low rack
■ Pancakes, waffles	HI - MOIST	pan
Pies, single crust	MED - MOIST	high rack
Pies, double crust	MED LO - DRY	high rack
■ Pizza	HI - MOIST	low rack
Pork	MED HI - MOIST	low rack
Potatoes, baked	MED - MOIST	high rack
■ Potatoes, mashed	MED HI - MOIST	low rack
■ Poultry	HI - MOIST	low rack
■ Vegetables	MED HI - MOIST	low rack

Warming Serving Bowls and Plates

- Use only cookware approved for oven use. Follow cookware manufacturer's instructions, especially when using glass or plastic cookware.

Raising (Proofing) Bread

1. Cover dough with lightly oiled wax paper and place temperature safe pan(s) directly on bottom of drawer.
 2. Set control knob to PROOF setting.
 3. Place vent on MOIST setting.
 4. Check dough periodically for proofing progress.
 5. Verify doneness by pressing 2 fingers ½ inch into dough; if indentation remains, the dough is ready.
 6. For second proofing of dough, place temperature safe bowl directly on bottom of drawer.
 7. Follow steps 2 through 4.
-

Using Aluminum Foil

Do not line drawer with aluminum foil.

- **Keep food covered** if it was cooked with a cover on it.
- **Use narrow strips** of foil to shield piecrust edges from further browning in drawer.
- **Place tent-shaped foil** loosely over meat or poultry to prevent dryness and further browning while in the drawer.
- **The use of aluminum foil** to cover foods may cause moisture to collect and drip into the drawer.

CARING FOR YOUR WARMING DRAWER

⚠ WARNING



Explosion Hazard

Do not store flammable materials such as gasoline near this appliance.

Doing so can result in death, explosion, or fire.

Drawer Slides

- The drawer slides allow you to fully extend the drawer for easier cleaning. If necessary, the drawer can be removed.
 - Load capacity for the drawer and slides is 100 lbs (45 kg).
-

Removing the Drawer

Remove all items from inside the Warming Drawer and allow the unit to cool completely before attempting to remove the drawer.

1. Pull drawer to its full open position.
2. Press tab down on right (shown) and lift tab upward on left (not shown), then slide drawer out 1 inch to disengage latch.

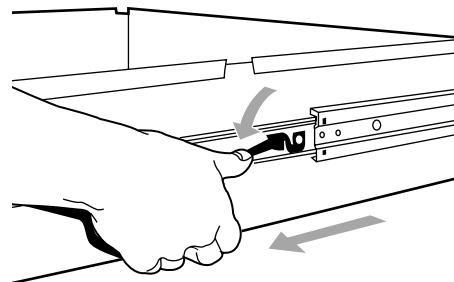

3. Carefully remove the drawer from the slides holding on to the sides, not the drawer front.

Replacing the Drawer

1. Align the drawer guides with the receiving slides.

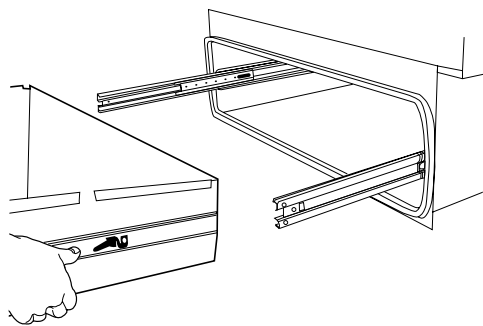

2. Push drawer in completely. Gently open and close drawer to ensure it is seated properly on the slides.

Cleaning the Drawer

Before cleaning, always make sure that all controls are turned off and the drawer is cool. Refer to the instructions on the containers of all cleaning products before using them to clean your drawer.

Control knob

- Soap and water
Do not use steel wool or abrasive cleaners.
Pull knob straight away from control panel.
Wash, rinse and dry with soft cloth.

Stainless steel surfaces (control panel, drawer cavity and drawer front)

Routine cleaning and fingerprints

- Liquid detergent/soap and water, or all-purpose cleaner
Wipe with damp cloth or sponge, then wipe with clean water and dry.

Stubborn stains and baked-on residue

- Mildly abrasive cleanser or stainless-steel cleaners
To avoid marring the surface, rub in the direction of grain lines with a damp cloth or sponge and cleanser. Wipe thoroughly with clean water. Repeat if necessary.

Hard water spots

- Vinegar
Swab or wipe with cloth. Wipe with clean water and dry.

DO NOT use steel wool or soap-filled scouring pads.

Rub in the direction of the grain line to avoid marring the surface.

Always wipe dry to avoid water marks.

If commercial cleaners are used, follow label directions. If product contains chlorine (bleach), rinse thoroughly with clean water and dry with a soft lint-free cloth. Chlorine is a corrosive substance.

DO NOT let commercial cleaners come in contact with the gasket.

Oven door glass and handle (for black, white and biscuit models)

- Paper towel and spray glass cleaner
Make sure oven is cool.
Follow directions provided with the cleaner.
OR
■ Warm, soapy water and a nonabrasive, plastic scrubbing pad
Wash, wipe with clean water, and dry thoroughly.

Pans

- Mild soap and water
Wash, rinse and dry with soft cloth.
DO NOT put in dishwasher, discoloration will occur.

Oven rack

- Steel-wool pad and warm, soapy water
Wash, rinse and dry thoroughly.

TROUBLE-SHOOTING

Drawer does not work

- Is the drawer connected to a power source?
Refer to installation instructions to ensure proper installation.
- Has the household fuse or circuit breaker been tripped?
Replace the fuse or reset the circuit.
- Power switch is in the "ON" position and the indicator light is not illuminated.
Reset unit by turning the Power switch to "OFF" and then "ON". The unit was in the timer mode and ran out of time.

Drawer does not slide properly

- Has the drawer been mounted properly on the slides?
Remove and remount the drawer on the slides. See the "Caring for Your Warming Drawer" section for instructions.
- Has the drawer been over-loaded?
Weight inside drawer should not exceed 100 lbs.
- Is the drawer load uneven?
Redistribute the contents to balance the weight evenly.

There is excessive moisture on the drawer

- Did you allow preheating time?
Preheat the drawer before each use. See "Using Your Warming Drawer" section for instructions.
- Is the Moist-Dry setting correct?
Set the Moist-Dry slide to "DRY" to vent the moisture.
- Did you cover food with aluminum foil?
See the "Using Aluminum Foil" section for instructions.

Drawer did not shut off automatically

- Have you bypassed the timer?
Check the Timer Override switch, if the light is "ON" you have to shut drawer off manually. The Timer Override switch must be in the "OFF" position for the Timer to function properly.

ASSISTANCE OR SERVICE

Before calling for assistance or service, please check "Troubleshooting." It may save you the cost of a service call. If you still need help, follow the instructions below.

When calling, please know the purchase date and the complete model and serial number of your appliance. This information will help us to better respond to your request.

If you need replacement parts

If you need to order replacement parts, we recommend that you only use factory specified replacement parts. Factory specified replacement parts will fit right and work right because they are made with the same precision used to build every new KitchenAid® appliance.

To locate factory specified replacement parts in your area, call our Consumer Assistance Center telephone number or your nearest designated service center.

In the U.S.A.

Call the KitchenAid Consumer Assistance Center toll free: **1-800-422-1230**.

Our consultants provide assistance with:

- Features and specifications on our full line of appliances.
- Installation information.
- Use and maintenance procedures.
- Accessory and repair parts sales.
- Specialized customer assistance (Spanish speaking, hearing impaired, limited vision, etc.).
- Referrals to local dealers, repair parts distributors, and service companies. KitchenAid designated service technicians are trained to fulfill the product warranty and provide after-warranty service, anywhere in the United States.

To locate the KitchenAid designated service company in your area, you can also look in your telephone directory Yellow Pages.

For further assistance

If you need further assistance, you can write to KitchenAid with any questions or concerns at:

KitchenAid Brand Home Appliances
Consumer Assistance Center
c/o Correspondence Dept.
2000 North M-63
Benton Harbor, MI 49022-2692

Please include a daytime phone number in your correspondence.

WARRANTY KITCHENAID® WARMING DRAWER

FULL ONE-YEAR WARRANTY

For one year from the date of purchase, when this Warming Drawer is operated and maintained according to instructions attached to or furnished with the product, KitchenAid will pay for factory specified replacement parts and repair labor to correct defects in materials or workmanship. Service must be provided by a KitchenAid designated service company.

KitchenAid will not pay for:

1. Service calls to correct the installation of your Warming Drawer, to instruct you how to use your Warming Drawer, to replace house fuses or correct house wiring.
 2. Repairs when your Warming Drawer is used in other than normal, single-family household use.
 3. Damage resulting from accident, alteration, misuse, abuse, fire, flood, acts of God, or use of product not approved by KitchenAid.
 4. Replacement parts or repair labor costs for units operated outside the United States.
 5. Pickup and delivery. This product is designed to be repaired in the home.
 6. Repairs to parts or systems resulting from unauthorized modifications made to the appliance.
-

KITCHENAID CORPORATION SHALL NOT BE LIABLE FOR INCIDENTAL OR CONSEQUENTIAL DAMAGES.

Some states do not allow the exclusion or limitation of incidental or consequential damages, so this exclusion or limitation may not apply to you. This warranty gives you specific legal rights, and you may also have other rights which vary from state to state.

Outside the United States, a different warranty may apply. For details, please contact your authorized KitchenAid dealer.

If you need service, first see the "Troubleshooting" section of this book. After checking "Troubleshooting," additional help can be found by checking the "Requesting Assistance or Service" section or by calling the KitchenAid Consumer Assistance Center, **1-800-422-1230** (toll-free), from anywhere in the U.S.A.

9/99

Keep this book and your sales slip together for future reference. You must provide proof of purchase or installation date for in-warranty service.

Write down the following information about your Warming Drawer to better help you obtain assistance or service if you ever need it. You will need to know your complete model number and serial number. You can find this information on the model and serial number label, located on your appliance as shown in the Parts and Features section of this book.

Dealer name _____

Address _____

Phone number _____

Model number _____

Serial number _____

Purchase date _____

Free Manuals Download Website

<http://myh66.com>

<http://usermanuals.us>

<http://www.somanuals.com>

<http://www.4manuals.cc>

<http://www.manual-lib.com>

<http://www.404manual.com>

<http://www.luxmanual.com>

<http://aubethermostatmanual.com>

Golf course search by state

<http://golfingnear.com>

Email search by domain

<http://emailbydomain.com>

Auto manuals search

<http://auto.somanuals.com>

TV manuals search

<http://tv.somanuals.com>