

A Guide to TracVision G6

user's guide

- Operating Instructions



KVH TracVision® G6

Satellite Television

TracVision G6

User's Guide

Congratulations on your choice of the TracVision G6, one of the most advanced automatic satellite tracking systems available today. This user's guide provides all of the basic information required to use this system and receive the satellite entertainment you want. Detailed installation, configuration, and maintenance information is provided in the *TracVision G6 Technical Manual*.

Throughout this manual, important information is marked for your attention by these icons:



A helpful tip that either directs you to a related area within the manual or offers suggestions on getting the highest quality out of your system.



An alert to important information regarding procedures, product specifications, or product use.



Information about installation, maintenance, troubleshooting, or other mechanical issues.



An electrical safety warning to help identify electrical issues that can be a hazard to either this KVH product or a user.

Direct questions, comments, or suggestions to:

KVH Industries, Inc.
50 Enterprise Center
Middletown, RI 02842-5279 USA
Tel: +1 401 847-3327
Fax: +1 401 849-0045
E-mail: info@kvh.com
Internet: www.kvh.com

KVH Europe A/S
Ved Klaedebo 12
2970 Hoersholm Denmark
Tel: +45 45 16 01 80
Fax: +45 45 86 70 77
E-mail: info@kvh.dk
Internet: www.kvh.com

[Click here to go to our state-of-the-art Customer Support web page...the fastest and easiest way to get all of your questions answered!](#)

If you have any comments regarding this manual, please e-mail them to manuals@kvh.com. Your input is greatly appreciated!



KVH Part # 54-0161-01 Rev. D
© 2004, KVH Industries, Inc. All rights reserved.



TracVision G6 Serial Number



This serial number will be required for all troubleshooting or service calls made regarding this product.

TracVision® and KVH® are registered trademarks
of KVH Industries, Inc.

GyroTrac™ and TracNet™ are trademarks of KVH Industries, Inc.

DVB® (Digital Video Broadcasting) is a registered trademark of the DVB Project.

DIRECTV® is an official trademark of DIRECTV, Inc.,
a unit of GM Hughes Electronics.

DISH Network™ is an official trademark of
EchoStar Communications Corporation.

ExpressVu is a property of Bell ExpressVu, a wholly owned
subsidiary of Bell Satellite Services.

Table of Contents

1	Introduction	1
1.1	TracVision G6 System Overview	3
1.2	TracVision G6 Components	5
2	Using Your TracVision G6	7
2.1	Receiving Satellite Signals	9
2.2	Turning On the System	10
2.3	Changing Channels and Switching to the Second Satellite	11
2.4	Watching Television	12
2.5	Internet Access	13
3	Using the ADCU Interface	15
3.1	ADCU Interface Functions	17
3.2	Setting Display Brightness	19
3.3	Selecting TracVision or GyroTrac-only Operations	19
3.4	Turning Sleep Mode On/Off	20
3.5	Installing a New Satellite Pair	21
3.6	Selecting Active Satellite	22
4	Troubleshooting	23
4.1	Troubleshooting Matrix	25
4.2	Causes and Remedies for Common Operational Issues	26
4.3	GyroTrac-specific Issues	29
4.4	IRD Troubleshooting	29
4.5	Antenna Gyro and LNB Faults	30

1 – Introduction

This section provides a basic overview of the TracVision G6 system. It explains how the system works and describes the function of each component.

Contents

1.1	TracVision G6 System Overview	3
1.2	TracVision G6 Components	5

1.1 TracVision G6 System Overview

A complete satellite TV system, illustrated in Figure 1-1, includes the TracVision G6 antenna unit connected to the GyroTrac digital gyro-stabilized sensor, Advanced Digital Control Unit (ADCU), an IRD (satellite TV receiver), and a television set.

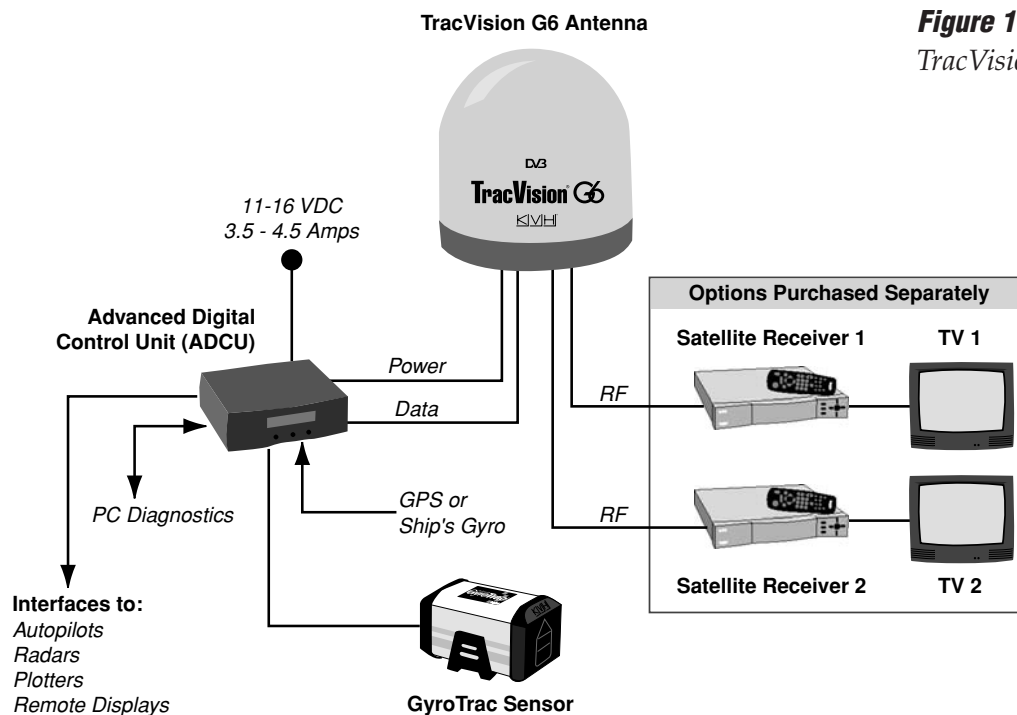

Figure 1-1

TracVision G6 System Diagram

System Compatibility

The TracVision G6 is fully compatible with Digital Video Broadcasting (DVB®) satellites, as well as DIRECTV®'s Digital Satellite Service (DSS) satellites. The system is also fully compatible with KVH's TracNet™ 2.0 Mobile High-speed Internet System (for more information about TracNet 2.0, please visit our web site at www.kvh.com).

In-motion Tracking

The TracVision G6 uses a state-of-the-art actively stabilized antenna system. Once the satellite is acquired, the antenna gyro continuously measures the heading, pitch, and roll of your vessel and sends commands to the antenna motors to keep the antenna pointed at the satellite at all times.

Figure 1-2

TracVision Identifies and Compensates for Vessel Motion

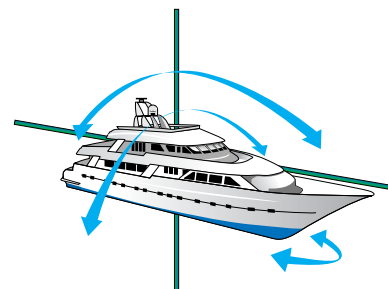



TracVision G6's default satellite pairs are:

N. America (US DIRECTV):
DSS_101 & DSS_119

Europe: Astra 1 & Hotbird WB

L. America (DIRECTV LA):
Galaxy 8W & None

Satellite Library

Your TracVision G6 includes a pre-programmed satellite library of North American, European, and Latin American satellite services. If the satellite service you wish to receive is not already in the satellite library, an authorized technician can add two additional satellites of your choice to the library.

Tables 1-1 and 1-2 list the possible satellite pairs that may be selected in North America and Europe. In Latin America, the system can track either Galaxy8W or Galaxy8E to receive DIRECTV Latin America service (Latin American LNB required). Contact the satellite TV service provider of your choice for complete details and a map of the service's coverage area.

Table 1-1

Available Satellite Pairs
- North America
(U.S.-style LNB required)

	DSS_101	DSS_119	Echo_61	Echo_110	Echo_119	Echo_148	Expressvu	ExpressTV
DSS_101		✓					✓	✓
DSS_119	✓						✓	✓
Echo_61				✓	✓		✓	✓
Echo_110			✓		✓	✓	✓	✓
Echo_119			✓	✓		✓	✓	✓
Echo_148				✓	✓		✓	✓
Expressvu	✓	✓	✓	✓	✓	✓		✓
ExpressTV	✓	✓	✓	✓	✓	✓	✓	

Table 1-2

Available Satellite Pairs - Europe
(European LNB required)

	Astra 1	Astra 2N	Astra 2S	Hispasat	Hotbird WB	Sirius	Thor	Arabsat	Nilesat
Astra 1		✓	✓		✓	✓		✓	
Astra 2N	✓				✓			✓	
Astra 2S	✓				✓			✓	
Hispasat									
Hotbird WB	✓	✓	✓			✓			
Sirius	✓				✓		✓		
Thor						✓			✓
Arabsat	✓	✓	✓						✓
Nilesat							✓	✓	

1.2 TracVision G6 Components

Your TracVision G6 system includes the following components:

Antenna Unit

The antenna unit houses the antenna positioning mechanism, low noise block (LNB), power supply, and control elements within a molded ABS radome. Weathertight connectors on the bottom of the baseplate join the power, signal, and control cabling from belowdecks units.



GyroTrac

TracVision G6 includes KVVH's GyroTrac digital gyrocompass for three-axis attitude/heading reference, ensuring superior open water performance in any sea conditions. GyroTrac can also operate as a fully functional, stand-alone heading sensor.

GyroTrac includes the following two components:

Sensor Module

The sensor module houses the system's compass/yaw sensor, inclinometer, rate gyros, and processing electronics and is waterproof to a depth of one meter.



Advanced Digital Control Unit (ADCU)

The ADCU is the user interface, providing access to the system and its functions through an LCD and three soft keys. The ADCU also serves as the system's junction box, allowing the system to use ship's power, interface with the sensor module, supply and receive data to/from the TracVision G6 system, and supply and receive data to/from other shipboard systems.



Integrated Receiver Decoder (IRD)

The IRD (purchased separately) receives satellite signals from the antenna unit for signal processing and channel selection, and sends the signals to the TV set for viewing. Please refer to the user's manual provided with your selected IRD for complete operating instructions.

2 — Using Your TracVision G6

This section explains everything you need to know to operate your TracVision G6 system. All operations are controlled through a simple user interface.

Contents

2.1	Receiving Satellite Signals	9
2.2	Turning On the System	10
2.3	Changing Channels and Switching to the Second Satellite	11
2.4	Watching Television	12
2.5	Internet Access	13

2.1 Receiving Satellite Signals

For TracVision G6 to receive satellite TV signals, the antenna must have a clear line of sight to the satellite. If you only receive intermittent signals or the antenna cannot find the satellite, check around your vessel for any objects that could be blocking the signal, such as other vessels, trees, buildings, other onboard equipment, etc.

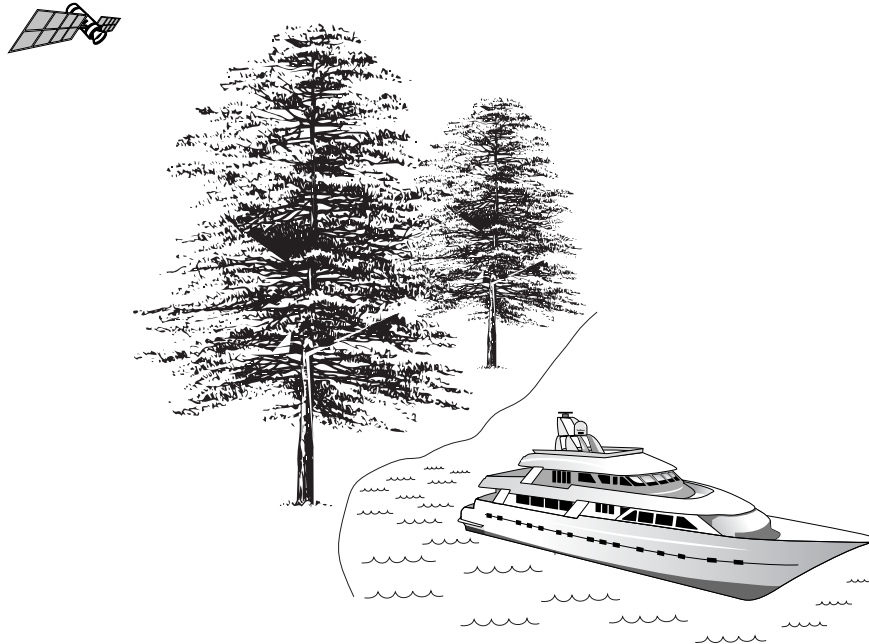

Figure 2-1

Be Aware of Objects that Might Block the Satellite Signals

You must also be located within the selected satellite's coverage area in order to receive its signal. Refer to your satellite television service manual to check the viable coverage area. *For your convenience, KVH provides links to several web sites that offer satellite coverage information. Simply go to our web site at: www.kvh.com/footprint.*



To minimize the time it takes the antenna to acquire the satellite, do not change the channel during the startup process or cable unwrap.



GPS must be turned on first if TracVision G6 is to use the GPS position data. If TracVision G6 is turned on before the GPS, TracVision G6 will use its default position while initializing.

2.2 Turning On the System

The TracVision G6 system is easy to use. Antenna unit initialization and satellite acquisition are completely automatic.

To use the TracVision G6 system, follow the steps below.

1. Turn on the IRD and the television. (Refer to your IRD user's manual for complete operating instructions for the IRD.)
2. If a GPS receiver is connected, ensure that it is turned on and has obtained an accurate position.
3. Apply power to the system.
 - a. ***If the antenna unit power cable is connected to the ADCU:***
Turn on the ADCU. This will turn on the GyroTrac sensor, the ADCU, and the antenna unit.
 - b. ***If the antenna unit is connected to a separate power source:***
Turn on the ADCU to turn on the GyroTrac sensor and the ADCU. Turn on the antenna unit.

If you are unsure how your system is wired, please check with your installer.

4. Avoid turning the vessel for 60 seconds after turning on the antenna to allow the antenna gyro to initialize properly.

2.3 Changing Channels and Switching to the Second Satellite

TracVision G6 can have a pair of satellites installed, either one of which can be the active satellite selection. There are several methods of selecting whether your TracVision G6 will track Satellite A or Satellite B based upon your location, type of install, IRD, and selected satellite service.

European Satellite Subscribers

If you are not using a multiswitch, switching from one satellite to the other is as easy as changing the channel using the IRD remote control. TracVision G6 will automatically switch from Satellite A to Satellite B and back again as necessary to receive your selected channel. If you are using a multiswitch, use the ADCU switching option described in *“Switching Satellites Using the ADCU” on page 12.*

DIRECTV Satellite Subscribers

DIRECTV subscribers in certain regions of the United States will require a DSS Plus™ IRD to receive broadcasts from multiple satellites.

If connected to the antenna’s RF1 connector, the DSS Plus IRD allows you to switch channels using the IRD remote control. If you are a DIRECTV subscriber, but do not have a DSS Plus IRD, or you are using a multiswitch, use the ADCU switching option described in *“Switching Satellites Using the ADCU” on page 12.*

EchoStar and ExpressVu Satellite Subscribers

EchoStar and ExpressVu subscribers will need to use the ADCU switching option, as described in *“Switching Satellites Using the ADCU” on page 12.*

DIRECTV Latin America Subscribers

If your TracVision G6 is equipped for use with the DIRECTV Latin America service, your antenna will search for and receive signals from one satellite (Galaxy 8W or Galaxy 8E). Therefore, there is no need to switch satellites.



The satellite configuration on your IRD must match the satellite setting on the TracVision G6 system.

*Satellite A on the TracVision G6 must be the same satellite as IRD Alternative 1 (or A, based on your IRD) and must be assigned the IRD DiSEqC 1 setting.**

*Satellite B on the TracVision G6 must be the same satellite as IRD Alternative 2 (or B, based on your IRD) and must be assigned the IRD DiSEqC 2 setting.**

Refer to your IRD user manual for complete instructions for your IRD.

**DiSEqC settings only apply to European systems and DIRECTV DSS Plus™ IRDs.*



When you switch from one satellite to another, all IRDs connected to the system will receive signals from the new satellite.

Switching Satellites Using the ADCU

If you're unable to switch between satellites using the IRD remote control, use the ADCU front panel buttons to select between Satellite A and Satellite B. Press the left button to select Satellite A and the right button to select Satellite B.

Figure 2-2
*Switching Satellites Using
the ADCU*

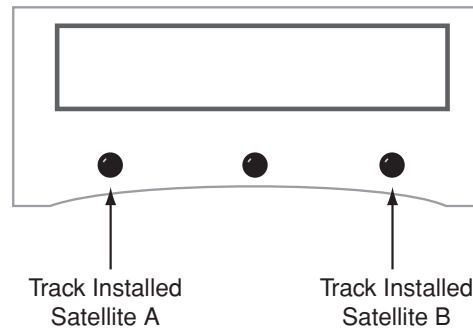

2.4 Watching Television

TracVision G6 is designed to operate as efficiently and as reliably as possible both when your vessel is in motion and at rest.

Cable Unwrap

The antenna can rotate a full 720° before reaching the end of its cable. If it does so, the system automatically unwraps the cable by quickly rotating the dish in the opposite direction. During this time, your television transmission will freeze momentarily while the cable unwraps and the antenna reacquires the satellite.

Conical Scan Tracking

The antenna uses conical scanning to maintain peak signal strength to the receiver and to update the satellite's position. When conical scan tracking is active, the antenna moves continually in a circular motion to sweep across the satellite's peak signal. The signal strength is then fed back to the control circuits to keep pointed in the direction of the strongest signal.

If the satellite signal is lost while the system is in conical scan track mode, the control software imposes a 45-second time-out delay. If the signal is not regained during that time, the antenna will search for the satellite signal. This is an automatic process that does not require user intervention.

Sleep Mode

When the vessel has come to a stop and holds its position for one minute (e.g., at a dock), the antenna unit enters Sleep Mode, which locks the antenna in place to conserve power. As soon as the vessel moves beyond a 1° - 2° window, or the RF level changes significantly, Sleep Mode automatically turns off and the system begins tracking the satellite again (or enters Search mode to find the satellite).



If you prefer, you may disable the Sleep Mode function. Refer to Section 3.4, "Turning Sleep Mode On/Off" on page 20 for details.

2.5 Internet Access

Your TracVision G6 can receive high-speed Internet data when used in conjunction with KVH's TracNet 2.0 Mobile High-speed Internet System. With TracNet 2.0, you get broadband Internet access on the move via satellite downloads and a wireless return path. For more information about TracNet 2.0 in North America and Europe, please visit our web site at www.kvh.com.



3 — Using the ADCU Interface

This section explains how to use some basic ADCU functions. You will use the ADCU to operate, control, and monitor the TracVision G6 and GyroTrac.

Contents

3.1	ADCU Interface Functions	17
3.2	Setting Display Brightness	19
3.3	Selecting TracVision or GyroTrac-only Operations	19
3.4	Turning Sleep Mode On/Off	20
3.5	Installing a New Satellite Pair	21
3.6	Selecting Active Satellite	22

3.1 ADCU Interface Functions

All TracVision G6 and GyroTrac operations are controlled and monitored using the ADCU. An LCD display shows navigation and configuration data and three soft keys enable you to perform a multitude of menu-driven tasks.

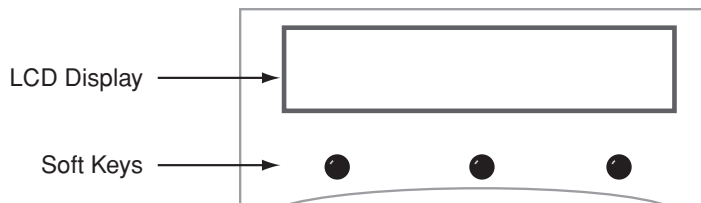

Figure 3-1
ADCU Front Panel

During the TracVision G6 installation process, the GyroTrac and the satellite selections should have been configured to your specifications as detailed in the *TracVision G6 Technical Manual*. Once the system is installed and functioning properly, the system will function automatically.

However, there may be instances in which you need to access certain settings via the ADCU interface. To assist you, KVH has provided the following information resources:

Quick Reference Guide

The quick reference guide on the following page illustrates the primary displays and the overall menu structure, allowing you to easily and quickly navigate among the ADCU menus.

Sections 3.2 through 3.6 of this User's Guide

While the system operates automatically, there may be instances where some adjustment may be required, either to the selected satellites or the ADCU display, for example. These menus, highlighted on the quick reference guide, are explained in greater detail in these sections.

The TracVision G6 Technical Manual

Section 3 of the *TracVision G6 Technical Manual* provides a detailed explanation of every menu option and system configuration setting. These menus should, for the most part, be accessed by authorized technicians.

GyroTrac™ Advanced Digital Control Unit (ADCU) Menu Quick Reference Guide

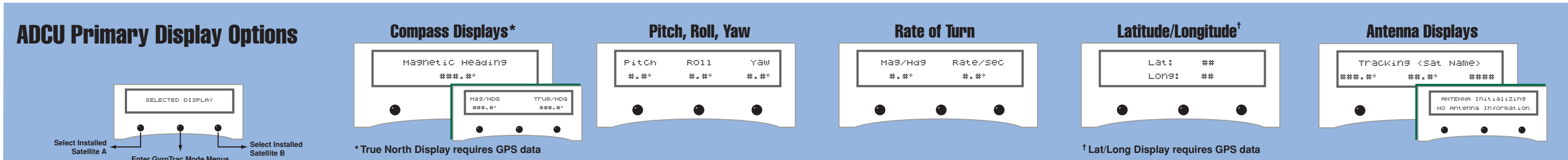

GyroTrac Mode Menus

Return to Selected Primary Display

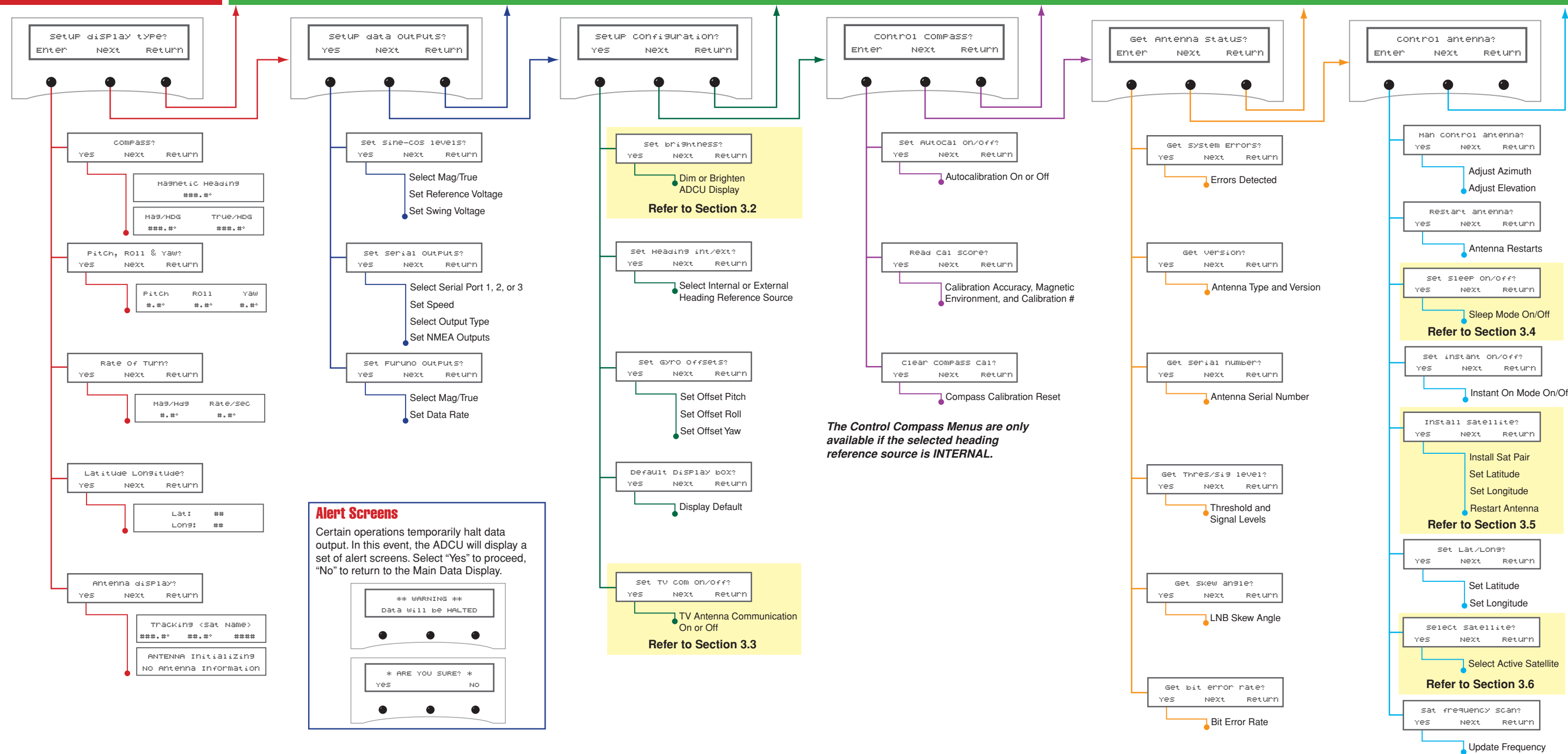

3.2 Setting Display Brightness

The ADCU display's brightness may be adjusted to suit your preferences. Press the right key to make the display brighter, the left key to make it dimmer. When you are satisfied with the setting, press the center key to accept the setting. Refer to the Quick Reference Guide on page 18 for instructions on reaching this menu.

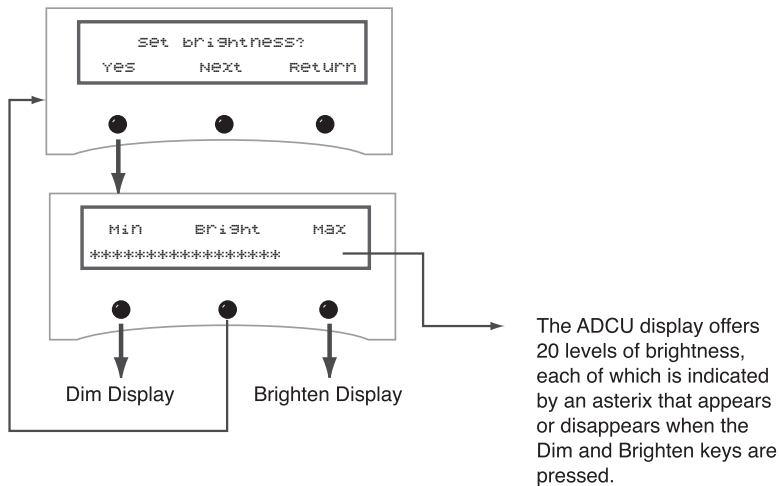

Figure 3-2

Display Brightness Controls

3.3 Selecting TracVision or GyroTrac-only Operations

GyroTrac's factory default configuration is to operate as a stand-alone system (**Antenna Comm: OFF**). Connecting a TracVision antenna will reconfigure GyroTrac to function as a component of a TracVision system (**Antenna Comm: ON**). Refer to the Quick Reference Guide on page 18 for instructions on reaching this menu.



If the antenna is not receiving data from the GyroTrac and the ADCU is not displaying antenna-specific menus, it may be because the antenna communication is turned off. Use this menu to check and turn antenna communications back on if necessary.

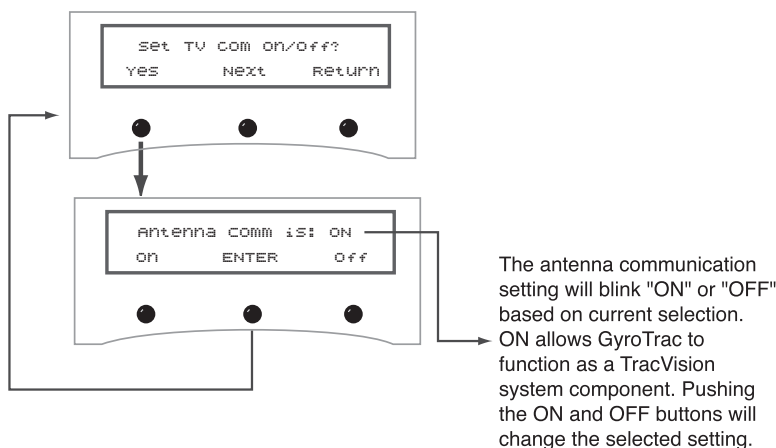

Figure 3-3

Selecting TracVision or GyroTrac-only Operations

3.4 Turning Sleep Mode On/Off

When the vessel has come to a stop and the antenna holds its position for one minute (e.g., at a dock), the antenna unit enters Sleep Mode, which locks the antenna in place and conserves power. As soon as the vessel moves beyond a 1° - 2° window, or the RF level changes significantly, the system will automatically begin tracking the satellite again (or enters Search mode to find the satellite). This convenient feature is ideal for when a vessel is docked and passengers want to watch TV. TracVision G6's default setting is for Sleep Mode to be ON. To change the setting, use the Sleep Mode menu. Refer to the Quick Reference Guide on page 18 for instructions on reaching this menu.

Figure 3-4
Turning Sleep Mode On/Off

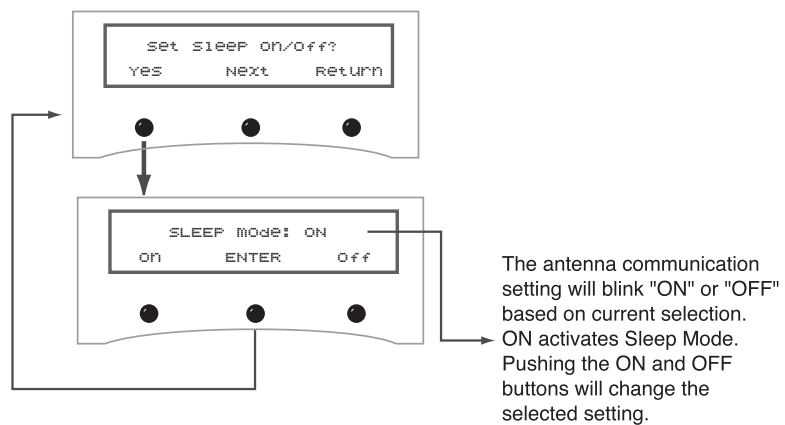

3.5 Installing a New Satellite Pair

TracVision G6 permits two satellite services (Satellites A and B) to be installed simultaneously. There is also an option for **NONE** on Satellite B, permitting single satellite operation. Refer to the Quick Reference Guide on page 18 for instructions on reaching this menu.

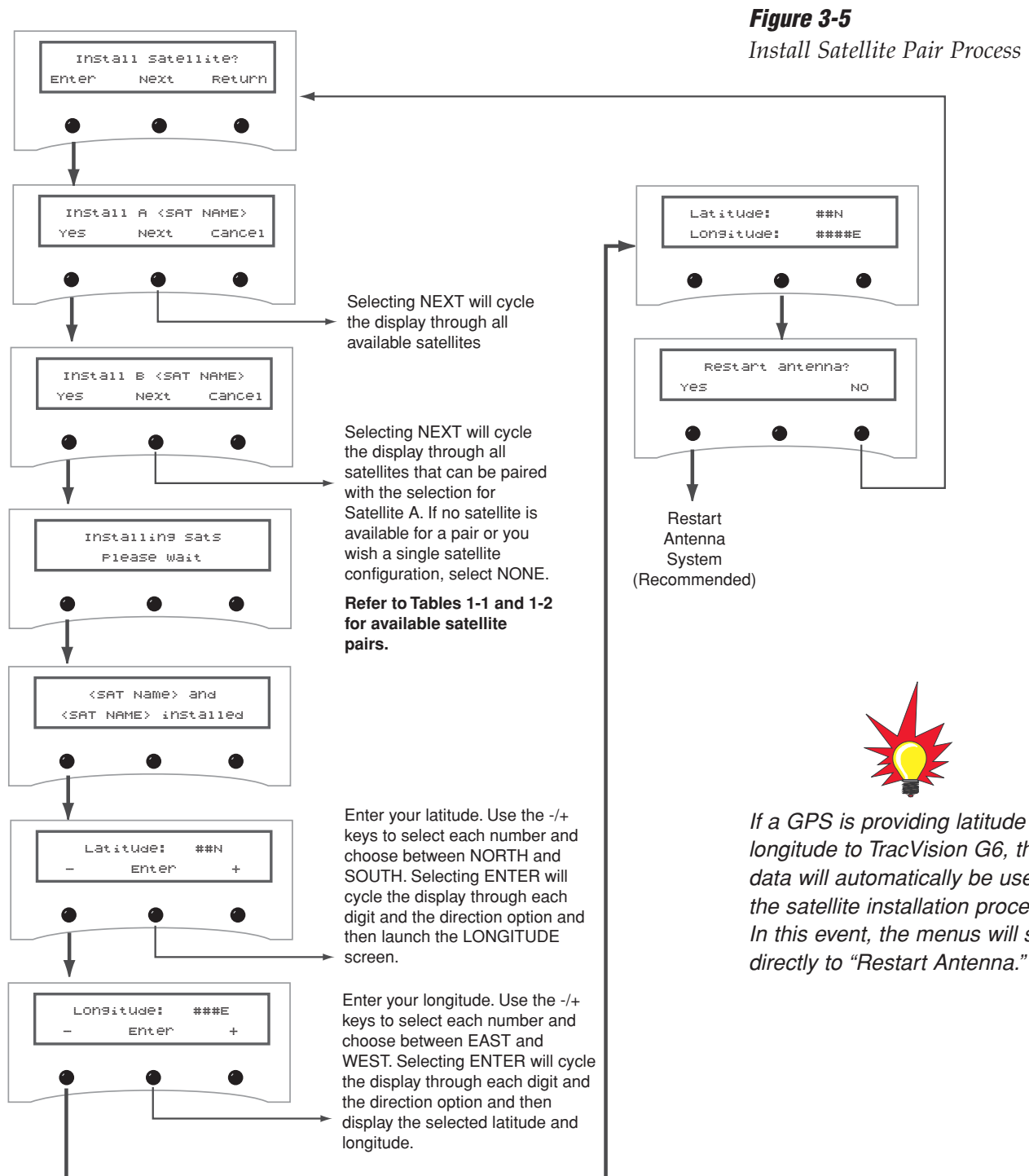

3.6 Selecting Active Satellite

After installing the pair of satellites, use the Select Satellite menu to choose which of the installed satellites will be active. This is also an effective way to see which satellite is being tracked at any given moment. Refer to the Quick Reference Guide on page 18 for instructions on reaching this menu.

Figure 3-6
Select Active Satellite

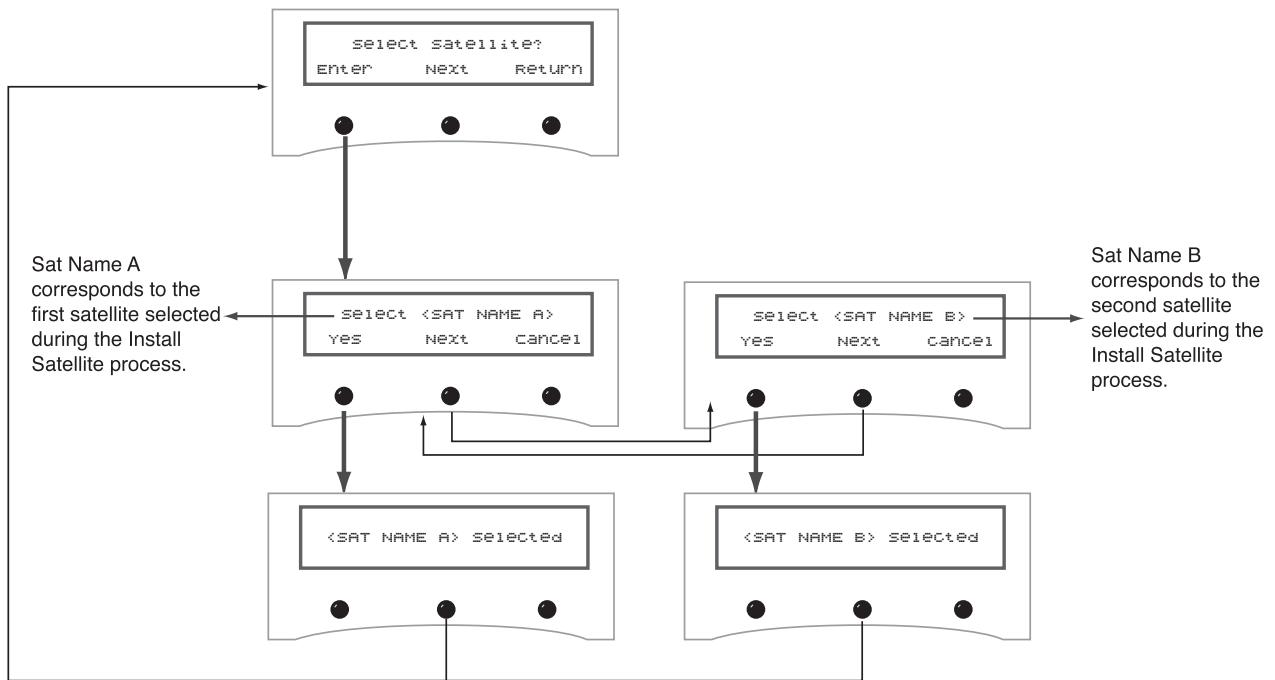

Once you know which satellite is being tracked, switching the active satellite can also be done at the main display, using the left and right buttons to toggle back and forth, as shown in Figure 3-7.

Figure 3-7
Select Active Satellite at the Main Display

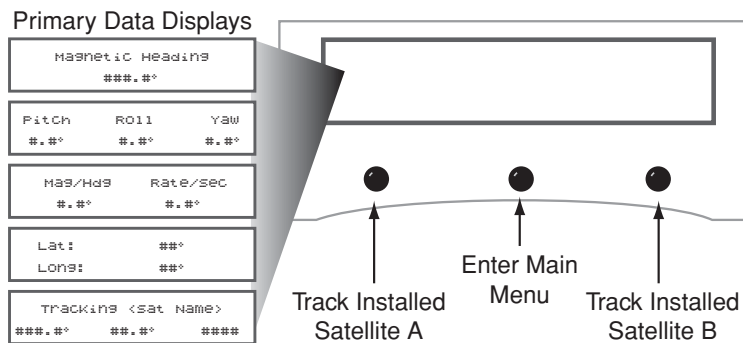

4 — Troubleshooting

This section identifies basic trouble symptoms and lists their possible causes and solutions.

Contents

4.1	Troubleshooting Matrix	25
4.2	Causes and Remedies for Common Operational Issues	26
4.3	GyroTrac-specific Issues	29
4.4	IRD Troubleshooting	29
4.5	Antenna Gyro and LNB Faults	30

4.1 Troubleshooting Matrix

The troubleshooting matrix shown in Table 4-1 identifies some trouble symptoms, their possible causes, and references to troubleshooting solutions.

Table 4-1
Troubleshooting Matrix

SYMPTOM	Section 4.2												
	POSSIBLE CAUSE (AND SOLUTION)												
	Blown fuse, low power, or improper wiring	Vessel turning during startup	Incorrect satellite configuration	Satellite signal blocked	Radar coverage issue	Satellite interference	Incorrect frequency data changed	Type of multiswitch used	Gyro Trac-specific issues	IRD faulty or improperly configured	Antenna gyro faulty	LNB assembly faulty	
Antenna non-functional	1												
Antenna not switching satellites	1	1	1	1			2	2		2			2
No picture on TV set			1	1	2		2	2		2			2
Certain channels do not work	1		1	1		3	2			2			2
Intermittent picture for short intervals		1	1	1	2		2	2				3	2
System works at dock but not on the move			1						3			3	
System will not find satellite	1	1	1	1	1	2	3	2	2	3	2	3	2
Snowy television picture	1							2			2		
Pixelating television picture	1		1		2		2			2	3		2
No antenna-specific menus on GyroTrac										3			
Antenna and GyroTrac not communicating	1									3			
No data output through Serial Port 3										3			

Key
 1 = Anyone can do
 2 = Electronics know-how recommended
 3 = Dealer service recommended



If you need help troubleshooting your system, please contact an authorized KVH dealer. To find an authorized dealer near you, visit www.kvh.com, or contact KVH directly at the numbers provided on the first page of this manual.

4.2 Causes and Remedies for Common Operational Issues

There are a number of common issues that can affect the signal reception quality or the operation of the TracVision G6. The following sections address these issues and potential solutions.

Blown Fuse, Low Power, or Wiring

If the antenna unit is installed but entirely non-responsive, there are three key factors to check as part of the troubleshooting process:

Blown Fuse

Move the antenna reflector slowly by hand. If the reflector does not move freely, a fuse is not the problem. If the reflector does move freely, one of the two fuses mounted on the CPU Board may have blown or been broken. The *TracVision G6 Installation and Technical Manual* provides detailed instructions for authorized service personnel who may be required to replace a fuse. Contact your local KVH dealer or service center for assistance.

Low Power

If the power cable from the antenna unit to the power source or ADCU is more than 15 m (50 ft), the power levels can decrease over the course of the cable, resulting in a voltage or current level at the antenna unit that is too low to power the system properly. The *TracVision G6 Technical Manual* provides detailed instructions for supplying adequate power to the antenna unit. Contact your local KVH dealer or service center for assistance.

Wiring

If the system has been improperly wired, it will not operate correctly. The *TracVision G6 Technical Manual* provides detailed instructions for authorized service personnel who may be required to check the wiring. Contact your local KVH dealer or service center for assistance.

Vessel Turning During Startup

If the vessel turns during the 60-second startup and initialization sequence that occurs immediately after turning on the power to the TracVision G6, the antenna gyro will record that variable motion as “standing still.” This may cause the antenna to track improperly. To solve this problem, turn TracVision G6 off for at least 10 seconds. Turn the system back on, making certain that the vessel is either motionless or traveling in a straight line for the 60 seconds immediately following power-up.

Incorrect Satellite Configuration (European Systems Only)

The satellite configuration on European IRDs must match the satellite settings on the TracVision G6 system.

- Satellite A on the TracVision G6 must be the same satellite as IRD Alternative 1 (or A, based on your IRD) and must be assigned the IRD DiSEqC 1 setting.
- Satellite B on the TracVision G6 must be the same satellite as IRD Alternative 2 (or B, based on your IRD) and must be assigned the IRD DiSEqC 2 setting.

Refer to your IRD user manual for complete instructions on configuring your IRD.

Satellite Signal Blocked

Satellite signals can be blocked or degraded by buildings, other vessels, or equipment on the vessel itself. Simply moving the vessel or obstruction will clear the signal.

Satellite Coverage Issue

TracVision G6 will provide outstanding reception within the 24" (60 cm) antenna coverage area for your satellite television service of choice. However, reception can be degraded as you approach the fringe coverage areas. Refer to your satellite television service manual to check the viable coverage area for a 24" (60 cm) antenna.



For your convenience, KVH provides links to several web sites that offer satellite coverage information. Simply go to our web site at www.kvh.com/footprint.

Radar Interference

The energy levels radiated by radar units can overload the antenna's front-end circuits. Check with your installer to make certain that the TracVision G6 antenna unit is in the optimal location with regard to your radar unit.

Satellite Frequency Data Changed

If some channels work while one or more other channels do not, or if the antenna is unable to find the satellite, the selected satellite's frequency data may have changed. This frequency data can be updated via the ADCU. Contact your local KVH dealer or service center for assistance.

Incorrect or Loose RF Connectors

A loose RF connector can reduce the quality of the satellite signal. Also, if you cannot switch satellites using your IRD remote, your IRD may be connected to the wrong antenna baseplate connector. The *TracVision G6 Technical Manual* provides instructions for authorized service personnel who may need to check the RF connections. Contact your local KVH dealer or service center for assistance.

Type of Multiswitch Used

An active (not passive) multiswitch must always be used to connect the TracVision G6 system to multiple IRDs. Contact your KVH dealer or service center for assistance.

4.3 GyroTrac-specific Issues

The GyroTrac is designed for reliable, easy use. This section provides a brief overview of some potential operational issues.

Issue 1:

System is installed correctly and power is available, but the system is non-functional.

Solution:

The *TracVision G6 Technical Manual* provides detailed instructions for authorized service personnel who may be required to replace the ADCU fuse. Contact your local KVH dealer or service center for assistance.

Issue 2:

System fails startup routine and ADCU displays “Errors Detected,” “No Data from Gyro/System Not Running,” or “No Data from Ant.”

Solution:

GyroTrac will not operate unless the system passes the startup self-tests. The following actions may be taken in this instance.

- Shut down the system, then restore power.
- If the system fails to pass the startup tests again, contact a KVH dealer or distributor for further assistance.

4.4 IRD Troubleshooting

The IRD that was provided with your satellite television service may also be the cause of less-than-ideal operation. First check the IRD’s configuration to ensure it is set up for the desired programming. In the case of a faulty IRD, refer to your IRD user’s manual for service and warranty information. If the IRD is both configured properly and fully functional, contact your local KVH dealer or service center for assistance.

4.5 Antenna Gyro and LNB Faults

The *TracVision G6 Technical Manual* provides detailed instructions for authorized service personnel who may be required to replace the antenna's gyro or Low Noise Block (LNB). Contact your local KVH dealer or service center for assistance.

KVH Industries Limited Warranty

TracVision G6

Limited Warranty on Hardware

KVH Industries, Inc. warrants the KVH product purchased against defects in materials for a period of TWO (2) years and against factory labor costs for a period of ONE (1) year from the date of original retail purchase by the original purchaser. It is the customer's responsibility to verify the date of purchase by returning the warranty card included with the product to KVH within 30 days of purchase, or by providing a copy of a dated sales receipt for the KVH product under warranty with the warranty claim. If this date cannot be verified, the warranty period will begin 30 days after the date of manufacture of the original product purchased.

If you discover a defect, KVH will, at its option, repair, replace or refund the purchase price of the product at no charge to you, provided you return it during the warranty period, transportation charges prepaid, to the factory direct. Please attach your name, address, telephone number, a description of the problem and a copy of the bill of sale or sales receipt as proof of date of original retail purchase, to each product returned to warranty service. Alternatively, you may bring the product to an Authorized KVH dealer/distributor for repair. During the first year, and if the product was installed by an Authorized KVH dealer/distributor (identified with the KVH Authorized dealer/distributor list), KVH will cover the dealer's/distributor's labor charges for warranty repairs, provided the dealer/distributor contacts KVH for pre-approval of the charges. Approval of charges is at KVH's sole discretion.

This Limited Warranty does not apply if the product has been damaged by accident, abuse, misuse or misapplication or has been modified without the written permission of KVH; if any KVH serial number has been removed or defaced; or if any factory-sealed part of the system has been opened without authorization.

Return Authorization

A Return Material Authorization is required prior to returning the product to KVH Industries. Please call our Technical Support Department at +1 401 847-3327 or send an e-mail to techs@kvh.com to obtain the RMA number. Write the number in large, clear characters on the outside of the box. To avoid confusion and misunderstandings, shipments without an RMA number clearly visible on the outside box will be refused and returned to you at your expense. If possible, use the original box and packing material to protect the equipment from damage in shipment. KVH assumes no responsibility for warranty shipments from the customer to the factory if not shipped in the manner prescribed above.

THE EXPRESS WARRANTIES SET FORTH ABOVE ARE THE ONLY WARRANTIES GIVEN BY KVH WITH RESPECT TO ANY PRODUCT FURNISHED HEREUNDER; KVH MAKES NO OTHER WARRANTIES, EXPRESS, IMPLIED OR ARISING BY CUSTOM OR TRADE USAGE, AND SPECIFICALLY DISCLAIMS ANY WARRANTY OF MERCHANTABILITY OR OF FITNESS FOR A PARTICULAR PURPOSE. SAID EXPRESS WARRANTIES SHALL NOT BE ENLARGED OR OTHERWISE AFFECTED BY TECHNICAL OR OTHER ADVICE OR SERVICE PROVIDED BY KVH IN CONNECTION WITH ANY PRODUCT.

KVH's liability in contract, tort or otherwise arising out of or in connection with any product shall not exceed the price paid for the product. IN NO EVENT SHALL KVH BE LIABLE FOR SPECIAL, PUNITIVE, INCIDENTAL, TORT OR CONSEQUENTIAL DAMAGES OR LOST PROFITS OR GOODWILL (INCLUDING ANY DAMAGES RESULTING FROM LOSS OF USE, DELAY IN DELIVERY OR OTHERWISE) ARISING OUT OF OR IN CONNECTION WITH THE PERFORMANCE OR USE OR POSSESSION OF ANY PRODUCT, OR ANY OTHER OBLIGATIONS RELATING TO THE PRODUCT, EVEN IF KVH HAS BEEN ADVISED OF THE POSSIBILITY OF SUCH DAMAGES.

If any implied warranty, including implied warranties of merchantability and fitness for a particular purpose, cannot be excluded under applicable law, then such implied warranty shall be limited in duration to ONE (1) YEAR from the date of the original retail purchase of this product by the original purchaser.

Some states/countries do not allow the exclusion or limitation of implied warranties or liability for incidental or consequential damages, so the above limitations may not apply to you. This warranty gives you specific legal rights, and you may also have other rights which vary from state/country to state/country.



KVH Industries, Inc.

50 Enterprise Center Middletown, RI 02842-5279 U.S.A.

Phone: +1 401 847-3327 Fax: + 1 401 849-0045

E-mail: info@kvh.com Internet: www.kvh.com

KVH Europe A/S

Ved Klaedebo 12 2970 Hoersholm Denmark

Phone: +45 45 160 180 Fax: +45 45 867 077

E-mail: info@kvh.dk Internet: www.kvh.com

TVG6 U/G Cover 10/00

Free Manuals Download Website

<http://myh66.com>

<http://usermanuals.us>

<http://www.somanuals.com>

<http://www.4manuals.cc>

<http://www.manual-lib.com>

<http://www.404manual.com>

<http://www.luxmanual.com>

<http://aubethermostatmanual.com>

Golf course search by state

<http://golfingnear.com>

Email search by domain

<http://emailbydomain.com>

Auto manuals search

<http://auto.somanuals.com>

TV manuals search

<http://tv.somanuals.com>