

# A Guide to TracVision R5/R4 owner's manual

- **Installation Instructions**
- **User's Guide**
- **Technical Manual**



**KVH TracVision® R5/R4**

Satellite Television

# Congratulations!

You have selected one of the most advanced land-mobile satellite tracking systems available today. KVH® Industries' TracVision® R5/R4 is designed for use with European and North American DVB-compatible satellite services as well as DIRECTV®. This manual provides detailed instructions on the proper installation, use, and maintenance of your TracVision R5/R4 system. **Before using this manual, be sure to check for any addenda, which might detail changes to the manual's information.**

Throughout this manual, important information is marked for your attention by these icons:



A helpful tip that either directs you to a related area within the manual or offers suggestions on getting the highest quality out of your system.



An alert to important information regarding procedures, product specifications, or product use.



Information about installation, maintenance, troubleshooting, or other mechanical issues.



An electrical safety warning to help identify electrical issues that can be a hazard to either this KVH product or a user.

Direct questions, comments, or suggestions to:

**KVH Industries, Inc.**  
50 Enterprise Center  
Middletown, RI 02842-5279 USA  
Tel: +1 401 847-3327  
Fax: +1 401 849-0045  
E-mail: [info@kvh.com](mailto:info@kvh.com)  
Internet: [www.kvh.com](http://www.kvh.com)

**KVH Europe A/S**  
Kokkedal Industripark 2B  
2980 Kokkedal, Denmark  
Tel: +45 45 160 180  
Fax: +45 45 160 181  
E-mail: [info@kvh.dk](mailto:info@kvh.dk)  
Internet: [www.kvh.com](http://www.kvh.com)

**If you have any comments regarding this manual, please e-mail them to [manuals@kvh.com](mailto:manuals@kvh.com). Your input is greatly appreciated!**



KVH Part # 54-0157 Rev. H  
© 2005, KVH Industries, Inc.



## TracVision R5/R4 Serial Number



*This serial number will be required for all troubleshooting or service calls made regarding this product.*

TracVision® and KVH® are registered trademarks of  
KVH Industries, Inc.

DVB® (Digital Video Broadcasting) is a registered trademark of the DVB Project.

DIRECTV® is an official trademark of DIRECTV, Inc.

DISH Network™ is an official trademark of  
EchoStar Communications Corporation.

ExpressVu is a property of Bell ExpressVu, a wholly owned  
subsidiary of Bell Satellite Services.

# Table of Contents

|          |   |            |
|----------|---|------------|
| <b>1</b> | <b>Introduction</b>   | <b>1-1</b> |
| 1.1      | Digital Satellite Television  | 1-1        |
| 1.2      | System Overview   | 1-2        |
| 1.2.1    | TracVision R5/R4 Components   | 1-3        |
| 1.2.2    | Satellite TV Receiver   | 1-3        |
| 1.3      | Materials Provided with TracVision R5/R4                                    | 1-4        |
| 1.3.1    | Additional Materials Required for TracVision R5/R4 Use                      | 1-5        |
| <b>2</b> | <b>Installation</b>   | <b>2-1</b> |
| 2.1      | Choosing the Best Location  | 2-3        |
| 2.2      | Mounting the Antenna Unit   | 2-4        |
| 2.3      | Connecting System Components  | 2-8        |
| 2.3.1    | Connecting the Antenna Data/Power Cable                                     | 2-9        |
| 2.3.2    | Connecting to Vehicle Power   | 2-10       |
| 2.3.3    | Connecting the Receiver Ground Wire   | 2-11       |
| 2.3.4    | Installing the Switchplate  | 2-11       |
| 2.3.5    | Connecting the Antenna RF Signal Cable to the Receiver                      | 2-12       |
| 2.3.5.1  | Installing Two Receivers and TVs<br>(North American Systems Only)           | 2-12       |
| 2.3.5.2  | Connecting Three or More Receivers and TVs<br>(North American Systems Only) | 2-13       |
| 2.3.6    | Sealing the Cable Access Hole   | 2-14       |
| 2.4      | Activating the Receiver   | 2-14       |
| 2.5      | Selecting the Active Satellite  | 2-15       |
| 2.5.1    | Installing Your Selected Satellites   | 2-16       |
| 2.5.2    | Programming User-defined Satellites   | 2-19       |
| 2.6      | Setting the Skew Angle (European Systems Only)                              | 2-24       |
| 2.7      | Testing the System  | 2-25       |
| 2.8      | Configuring TracVision R5/R4 for Remote Satellite Dish Operation            | 2-26       |
| 2.9      | Changing Geographic Location  | 2-27       |

|          |   |            |
|----------|---|------------|
| <b>3</b> | <b>Using Your TracVision R5/R4</b>                                | <b>3-1</b> |
| 3.1      | Turning On the System   | 3-1        |
| 3.2      | Changing Channels and Switching Between Satellites                | 3-2        |
| 3.2.1    | Using the Receiver Remote Control to Switch<br>Between Satellites | 3-2        |
| 3.2.2    | Using the TV/SAT Switch to Switch<br>Between Satellites           | 3-3        |
| 3.2.3    | Using a PC to Switch Between Satellites                           | 3-5        |
| 3.3      | Watching Television   | 3-6        |
| 3.4      | DISH 500 Mode   | 3-8        |
| <b>4</b> | <b>Troubleshooting</b>  | <b>4-1</b> |
| 4.1      | Causes and Remedies for Common Operational Issues                 | 4-1        |
| 4.1.1    | Blown Fuse or Improper Wiring                                     | 4-2        |
| 4.1.2    | Incorrect Satellite Configuration                                 | 4-2        |
| 4.1.3    | Satellite Signal Blocked  | 4-2        |
| 4.1.4    | Dew or Rain Pooling on Dome                                       | 4-3        |
| 4.1.5    | Satellite Coverage Issue  | 4-3        |
| 4.1.6    | Vehicle Turning During Startup ( <i>TracVision R5 only</i> )      | 4-3        |
| 4.1.7    | Incorrect or Loose RF Connectors                                  | 4-4        |
| 4.1.8    | Type of Multiswitch Used<br>(North American Systems Only)         | 4-4        |
| 4.1.9    | Stationary Use Only ( <i>TracVision R4 only</i> )                 | 4-4        |
| 4.2      | Receiver Troubleshooting  | 4-4        |
| 4.2.1    | Receiver Wiring   | 4-4        |
| 4.2.2    | Receiver Faulty   | 4-4        |
| 4.3      | Antenna Gyro and LNB Faults                                       | 4-5        |
| 4.4      | Computer Diagnostics  | 4-5        |
| <b>5</b> | <b>Maintenance</b>  | <b>5-1</b> |
| 5.1      | Warranty/Service Information                                      | 5-1        |
| 5.2      | Preventive Maintenance  | 5-1        |
| 5.3      | Replaceable Parts   | 5-2        |

|                   |   |            |
|-------------------|---|------------|
| <b>5.4</b>        | <b>Field Replaceable Unit Procedures</b> .....            | <b>5-3</b> |
| 5.4.1             | PCB Removal and Replacement .....                         | 5-5        |
| 5.4.2             | RF Detector/DVB Decoder .....                             | 5-6        |
| 5.4.3             | Antenna Gyro Assembly ( <i>TracVision R5 only</i> ) ..... | 5-7        |
| 5.4.4             | Antenna LNB Replacement .....                             | 5-8        |
| <b>5.5</b>        | <b>Preparation for Shipment</b> .....                     | <b>5-9</b> |
| <b>Appendix A</b> | <b>System Specifications</b> .....                        | <b>A-1</b> |
| <b>Appendix B</b> | <b>Switchplate Template</b> .....                         | <b>B-1</b> |

# 1 Introduction

## 1.1 Digital Satellite Television

Your new TracVision R5/R4 satellite antenna is fully compatible with the Digital Video Broadcasting (DVB) satellites, which use the international standard for digital TV transmission, as well as Digital Satellite Service (DSS) services, such as DIRECTV. As a result, you will be able to receive and decode signals from your chosen satellite services with the proper programming and hardware (e.g., the satellite TV receiver).

Your TracVision R5/R4 comes with a pre-programmed “satellite library” of European and North American satellite services. When configuring the TracVision R5/R4, you may choose a pair of satellites from the library to be active in the system and with your receiver. For the antenna to receive signals from two satellites, they must be within 10° longitude of each other in orbit. As a result, certain satellites can only be paired with certain other satellites. Tables 1-1 and 1-2 list the possible satellite pairs that may be selected in North America and Europe. *If the satellite service you wish to receive is not already in the satellite library, you may also add two additional satellites of your choice to the library.*

**Table 1-1**

*Available N. American Satellite Pairs (U.S.-style LNB required)*

|           | DSS_101 | DSS_119 | Echo_61 | Echo_110 | Echo_119 | Echo_148 | Expressvu | ExpressTV |
|-----------|---------|---------|---------|----------|----------|----------|-----------|-----------|
| DSS_101   |         | ✓       |         |          |          |          | ✓         | ✓         |
| DSS_119   | ✓       |         |         |          |          |          | ✓         | ✓         |
| Echo_61   |         |         |         | ✓        | ✓        |          | ✓         | ✓         |
| Echo_110  |         |         | ✓       |          | ✓        | ✓        | ✓         | ✓         |
| Echo_119  |         |         | ✓       | ✓        |          | ✓        | ✓         | ✓         |
| Echo_148  |         |         |         | ✓        | ✓        |          | ✓         | ✓         |
| Expressvu | ✓       | ✓       | ✓       | ✓        | ✓        | ✓        |           | ✓         |
| ExpressTV | ✓       | ✓       | ✓       | ✓        | ✓        | ✓        | ✓         |           |

**Table 1-2**

Available European Satellite Pairs  
(European LNB Required)

|          | Astra 1 | Astra 2N | Astra 2S | Hispasat | Hotbird | Sirius | Thor |
|----------|---------|----------|----------|----------|---------|--------|------|
| Astra 1  |         | ✓        | ✓        |          | ✓       | ✓      |      |
| Astra 2N | ✓       |          |          |          | ✓       |        |      |
| Astra 2S | ✓       |          |          |          | ✓       |        |      |
| Hispasat |         |          |          |          |         |        |      |
| Hotbird  | ✓       | ✓        | ✓        |          |         | ✓      |      |
| Sirius   | ✓       |          |          |          | ✓       |        | ✓    |
| Thor     |         |          |          |          |         | ✓      |      |



If you are a **DISH 500** customer or you have 3 or more receivers, you can order the optional TV/SAT Switch – **free of charge**. Simply fill out the order form located at the back of this manual and fax it to KVH at +1 401 845-8190.

## 1.2 System Overview

A complete satellite TV system includes the TracVision R5/R4 connected to a receiver and a television set. The optional TV/SAT Switch allows you to select a satellite at the press of a button. A desktop or laptop computer is used to configure the system and conduct diagnostics. The complete system is illustrated in Figure 1-1.

System specifications are provided in *Appendix A*.

**Figure 1-1**

TracVision R5/R4 System Configuration

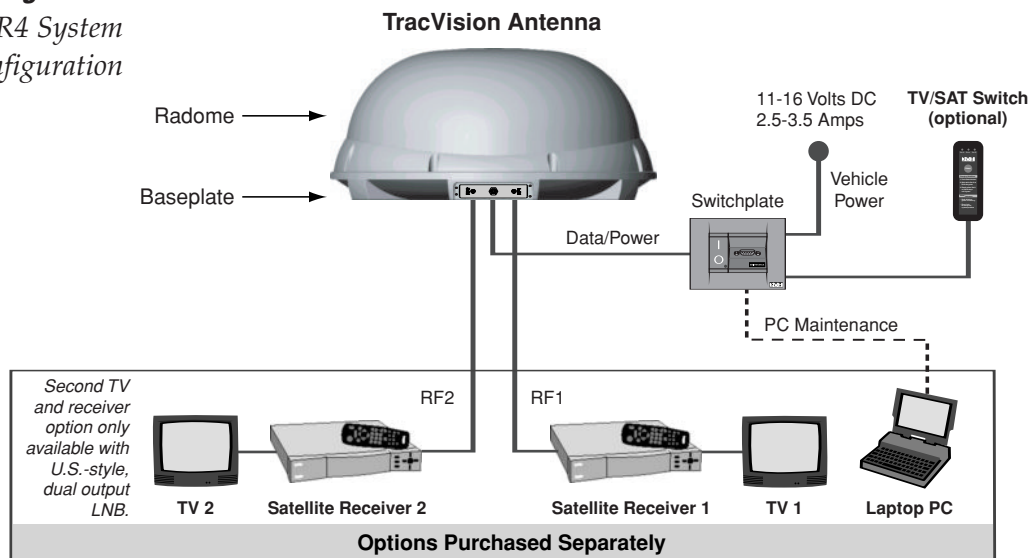



## **In-motion Tracking (*TracVision R5 only*)**

The TracVision R5 employs a state-of-the-art actively stabilized antenna system. Once the satellite is acquired, the antenna gyro continuously measures your vehicle's motion and position, and transmits commands to the antenna motors to keep the antenna pointed at the satellite at all times.

### **1.2.1 TracVision R5/R4 Components**

The antenna unit includes the antenna positioning mechanism, signal front end, power supply, and control elements. The antenna is a parabolic dish mounting a low noise block (LNB) converter with a built-in preamplifier. The European configuration includes a single-output LNB while the North American system uses a dual-output LNB. A molded ABS radome encloses the fiberglass baseplate and is secured in place with standard fasteners. Connectors on the back of the baseplate join the power, signal, and control cabling from units inside the vehicle.

### **1.2.2 Satellite TV Receiver - *Sold Separately***

The receiver (purchased separately) receives satellite signals from the antenna unit for signal processing and channel selection, and sends the signals to the TV set for viewing. Please refer to the User's Manual provided with your selected receiver for complete operating instructions.



*KVH offers an upgrade kit (KVH Part #02-1026) that adds in-motion tracking capability to the TracVision R4, allowing you to receive satellite signals while on the move.*



*The dual-output LNB in the North American systems allows two receiver/TV pairs to be connected directly to the antenna. Three or more pairs can be connected to the system if an active multiswitch is used. Section 2.3.5, "Connecting the Antenna RF Signal Cable to the Receiver," provides installation directions for each of these options.*



*Before you can start watching satellite TV using your TracVision antenna, you will need to activate your receiver. Refer to Section 2.4, "Activating the Receiver," for more details.*

## 1.3 Materials Provided with TracVision R5/R4

Table 1-3 lists the units, cables, and materials packed in the TracVision R5/R4 package by name and KVH part number.

**Table 1-3**

*TracVision R5/R4 Packing List*



*Cables for the TracVision R5/R4 are stored beneath the antenna unit during shipping.*

| Component  | KVH Part No.   |
|--|--|
| Antenna Unit ( <i>TracVision R5</i> ), comprising: | 01-0225-19 <sup>†</sup><br>01-0225-22 <sup>††</sup><br>01-0225-25 <sup>†††</sup><br>01-0225-28 <sup>††††</sup> |
| Baseplate Assembly ( <i>TracVision R5</i> )        | 02-1245-01*<br>02-1245-03**  |
| Radome Assembly ( <i>TracVision R5</i> )           | 02-0953-03   |
| Antenna Unit ( <i>TracVision R4</i> ), comprising: | 01-0225-21 <sup>†</sup><br>01-0225-27 <sup>††</sup><br>01-0225-30 <sup>†††</sup><br>01-0225-24 <sup>††</sup>   |
| Baseplate Assembly ( <i>TracVision R4</i> )        | 02-1245-02*<br>02-1245-04**  |
| Radome Assembly ( <i>TracVision R4</i> )           | 02-0953-05   |
| RF Cable (28 ft/8.5 m)                             | 32-0417-28   |
| Data/Power Cable (28 ft/8.5 m)                     | 32-0730-28   |
| PC Cable (6 ft/1.8 m)                              | 32-0628-06   |
| Kitpack <sup>***</sup>                             | 72-0101  |
| Owner's Manual                                     | 54-0157  |
| Receiver Ground Wire                               | 32-0583-50   |
| Switchplate  | 02-1023-01   |
| TV/SAT Switch ( <i>optional</i> )                  | 01-0245  |

<sup>†</sup> European TracVision R5/R4 system

<sup>††</sup> North American TracVision R5/R4 system (set to DIRECTV)

<sup>†††</sup> North American TracVision R5/R4 system (set to DISH Network)

<sup>††††</sup> North American TracVision R5/R4 system (set to ExpressVu)

\* Baseplate assembly with single-output LNB

\*\* Baseplate assembly with dual-output LNB

\*\*\* A complete listing of kitpack contents is provided in Table 2-2.

### 1.3.1 Additional Materials Required for TracVision R5/R4 Use

To make full use of your new TracVision R5/R4 and receive satellite TV on the road, you will need to provide/purchase the following:

- Television
- Appropriate receiver for your selected satellite TV service



*In North America, you can purchase and/or activate a receiver directly from KVH. Call KVH at 1-888-584-4163 for details.*

## 2 Installation

Your TracVision R5/R4 is designed for simple installation and setup. Just follow these easy steps:

| Step                                | Refer to Section... |
|-------------------------------------|---------------------|
| 1. Choose the hardware locations    | 2.1                 |
| 2. Mount the antenna unit           | 2.2                 |
| 3. Connect system components        | 2.3                 |
| 4. Activate the receiver            | 2.4                 |
| 5. Select active satellite          | 2.5                 |
| 6. Set the skew angle (Europe only) | 2.6                 |
| 7. Check out system                 | 2.7                 |
| 8. Configure for remote dish use    | 2.8                 |

**Table 2-1**

*Installation Process*



*Plan the entire installation before proceeding! Take into account component placement, cable running distances between units, and accessibility to the equipment after installation.*

### Tools and Materials Required

- Electric drill
- $\frac{3}{16}$ " (5 mm),  $\frac{5}{32}$ " (4 mm), and  $\frac{3}{32}$ " (2.5 mm) drill bits and  $\frac{3}{4}$ " (19 mm) hole saw and auger bit
- $\frac{1}{2}$ " wrench
- #2 Phillips and #0 flat tip screwdrivers
- RG-6 or RG-11 (75 ohms) RF cable (if installing two RF cables - refer to *Section 2.3.5* for details)
- Silicone sealant, RTV, or Sikaflex
- $\frac{7}{16}$ " open end wrench
- Construction adhesive (e.g., Liquid Nails)
- Rivet gun and  $\frac{3}{16}$ " (5 mm) rivets (or other fastener suitable for your specific roof construction)
- PC with Windows HyperTerminal or download the KVH Flash Update Wizard (available for free at [www.kvh.com/wizard](http://www.kvh.com/wizard))

## Kitpack Contents

Table 2-2 lists the materials provided in the kitpack.

**Table 2-2**  
*Kitpack Contents*

| <b>Part</b>                                     | <b>Qty.</b> | <b>KVH Part No.</b> |
|---|-------------|---------------------|
| Tie-wraps                                       | 5           | 22-0013             |
| Clamshell ventilator                            | 1           | 19-0230             |
| #6 x $\frac{3}{4}$ " thread-forming screws      | 3           | 14-0298-12          |
| $\frac{1}{4}$ "-20 x $\frac{5}{8}$ " hex screws | 4           | 14-0250-10          |
| $\frac{1}{4}$ " flat washers                    | 4           | 14-0251             |
| $\frac{3}{8}$ " hole plugs                      | 2           | 19-0282-06          |

## 2.1 Choosing the Best Location

- Since the TracVision antenna requires a clear view of the southern sky to receive satellite signals, the ideal antenna site has an unobstructed view of the horizon/satellite all around.
- Keep the antenna clear of any obstructions on the roof (e.g., air conditioners). The antenna requires a 15° to 75° look angle to receive satellite signals.

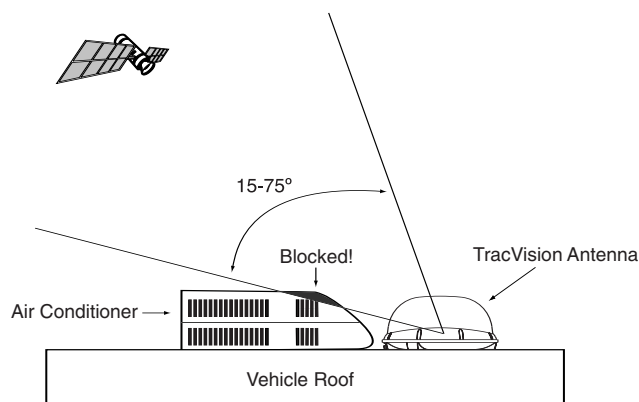

**Figure 2-1**  
Antenna Blockage

- Consider the location of the antenna relative to the location of any equipment or necessary wiring within the vehicle.
- Be sure to mount the antenna on a horizontal surface. When placed flat on the mounting surface, the mounting plates should be less than  $\frac{7}{16}$ " above the mounting surface (see Figure 2-2). **Any larger gap will warp the baseplate and seriously damage the antenna.**

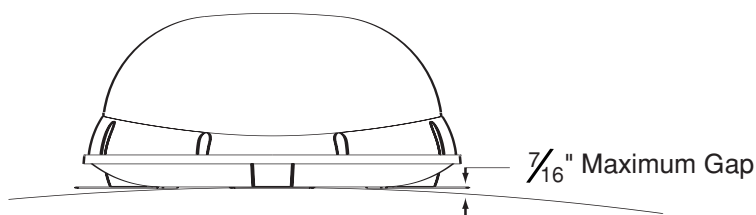

**Figure 2-2**  
Maximum Mounting Surface Slope



Always lift the antenna unit by the gray baseplate, never by the radome or any portion of the antenna assembly!

## 2.2 Mounting the Antenna Unit

1. Make sure that you have chosen a suitable mounting location based upon the guidelines in Section 2.1, "Choosing the Best Location."
2. Remove the antenna unit from its shipping carton.
3. Position the antenna unit in the desired location on the centerline of the vehicle with the antenna's mounting plate arrows facing the front or rear of the vehicle. The proper orientation is illustrated in Figure 2-3.

**Figure 2-3**  
Proper Orientation of  
the Antenna Unit

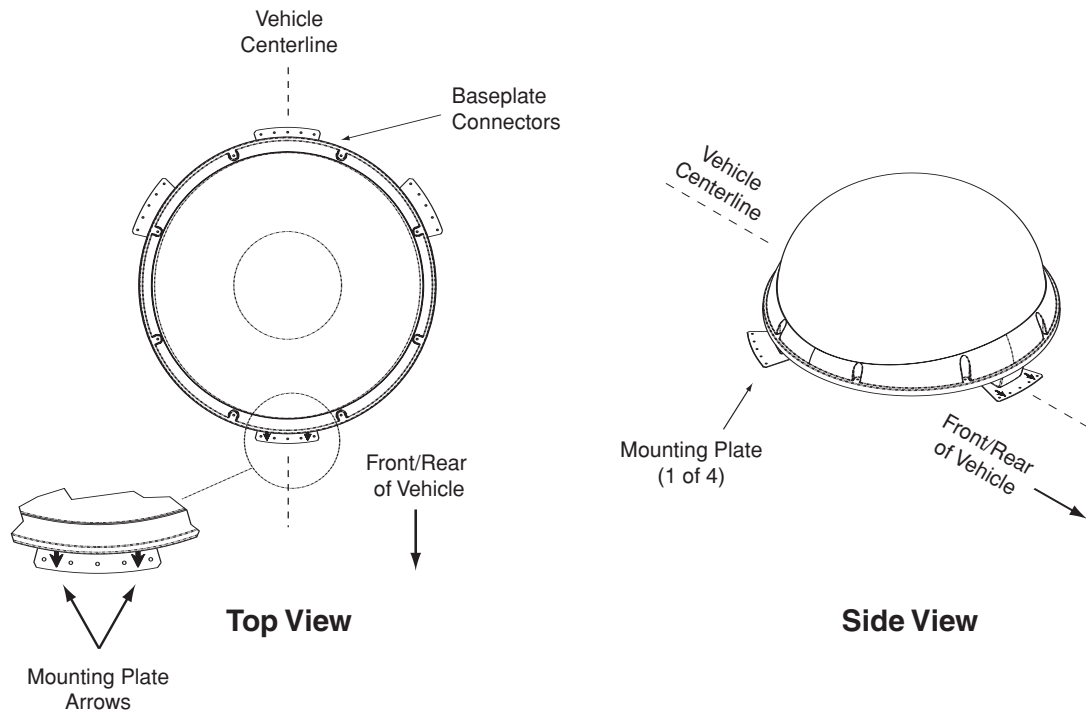

The mounting plate arrows may face either forward or backward along the centerline of the vehicle for more convenient installation.

4. While the antenna is in place, mark a location on the roof for the  $\frac{3}{4}$ " (19 mm) cable access hole to permit convenient cable access to the antenna's baseplate connectors.
5. Using the 4 mounting plates and each set of 5 holes as templates, drill  $20 \frac{3}{16}$ " (5 mm) holes through the roof of the vehicle.
6. Set aside the antenna unit and clean the roof's surface to remove any debris.

- Seal the two baseplate holes shown in Figure 2-4 with the plugs provided in the kitpack.

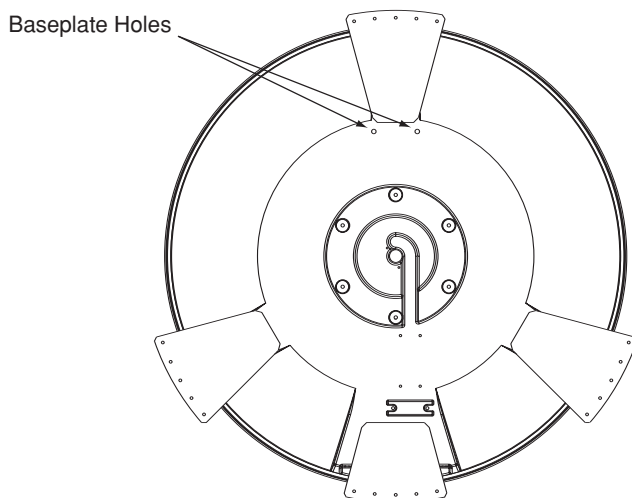
**Figure 2-4**

Antenna Baseplate (Bottom View)

- Apply construction adhesive to the bottom of the antenna's four mounting plates. If using a liquid construction adhesive, apply beads to the mounting plates in a zig-zag pattern.
- Reposition the antenna, lining up the mounting plate holes with the holes in the roof. Attach the mounting plates to the roof using  $\frac{3}{16}$ " (5 mm)-diameter rivets (or appropriate fasteners). Seal all rivet heads and edges with silicone.
- Remove and save the 8 pan head screws and flat washers that secure the radome to the baseplate. Carefully lift the radome straight up until clear of the antenna assembly and set aside.
- When the antenna unit is installed with the connectors facing the rear of the vehicle, the drain holes are located as shown in Figure 2-5.

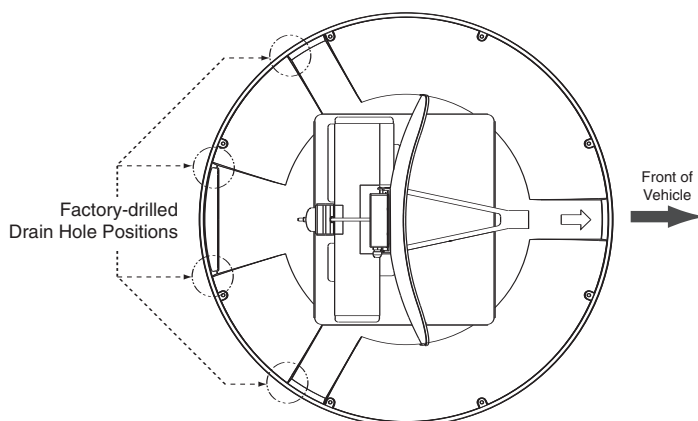

*If the roof's mounting surface is not perfectly flat as KVH recommends, make sure the baseplate does not warp when you attach the antenna's mounting plates. Refer to Section 2.1, "Choosing the Best Location," for further details.*

**Figure 2-5**

*Baseplate Connectors Facing Rear of Vehicle – Factory-drilled Drain Hole Locations*



11a. (Alternate Drain Hole Locations) If the antenna unit is installed with the connectors facing the front of the vehicle, drill out  $\frac{3}{16}$ " (5 mm)-drain holes in the rear-facing side of the baseplate as illustrated in Figure 2-6. The existing factory-drilled drain holes shown in Figure 2-5 must then be plugged with silicone rubber sealant.

**Figure 2-6**

Baseplate Connectors Facing Front of Vehicle – Recommended Drain Hole Locations



You **MUST** drill out the drain holes as indicated to ensure that any moisture that enters the baseplate is able to drain. Ensure that factory-drilled holes are completely sealed.

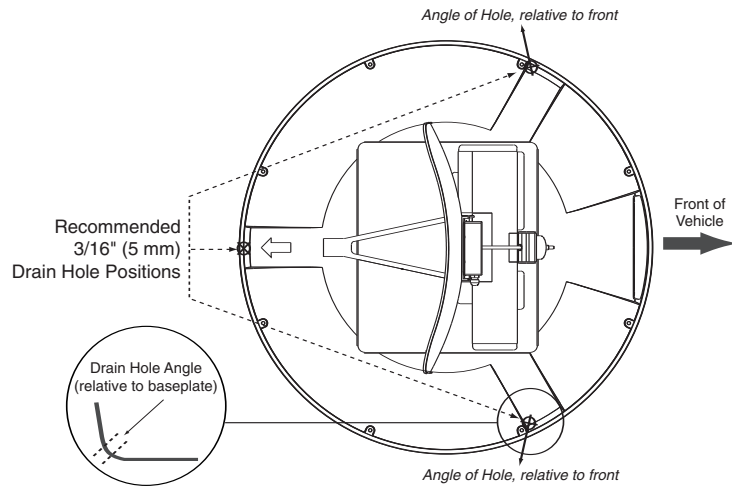

12. Cut the tie-wraps holding the antenna unit to the forward shipping restraint (see Figure 2-7).

**Figure 2-7**

Forward Shipping Restraint

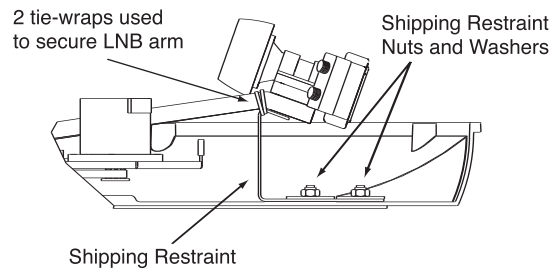

13. Remove the nuts and washers securing the shipping restraints to the baseplate. The shipping restraints are pictured in Figure 2-8.

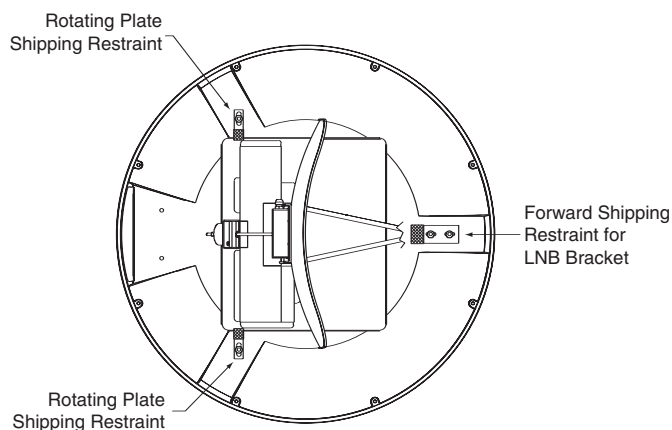

14. Remove the shipping restraints and replace the nuts and washers into their original positions. **All nuts and washers removed in Step 13 must be reinstalled. These nuts and washers secure the baseplate to the mounting plates.**
15. Place the radome onto the baseplate (labels facing the sides of the vehicle) and secure in place using the 8 pan head screws and flat washers removed in Step 10.
16. Drill the cable access hole (marked in Step 4) in the vehicle's roof.

**Figure 2-8**

*TracVision R5/R4 Shipping Restraints (Top View)*



*Do not discard the shipping restraints, washers, or the nuts. They should be saved for future use in case the antenna unit needs to be removed and shipped to another location. Four 1/4" x 5/8" hex head screws have been provided in the kitpack for shipping as the bolts used to hold the shipping restraints during initial shipping are integral parts of the mounting plates.*

## 2.3 Connecting System Components

The following sections provide instructions for properly wiring the antenna unit to the components inside the vehicle.

### Locating the Switchplate

A switchplate has been provided to serve as the hub of the TracVision R5/R4 wiring (with the exception of the RF cable, which will be connected to the receiver). This switchplate includes an ON/OFF switch and a DB9 maintenance port for easy access to the antenna unit's software and diagnostics. Follow the steps below to select and prepare the switchplate mounting location.

1. Select a location to mount the TracVision R5/R4 switchplate. It should be installed in a dry, flat location within reach of the cables that will connect to the antenna unit.
2. Once you've decided on a suitable location, create a panel cutout in the mounting surface. Figure 2-9 illustrates the mounting dimensions and a full-scale template has been provided in *Appendix B*. The connecting cables will be routed through this cutout.

**Figure 2-9**  
Switchplate Panel  
Cutout Dimensions



A full-scale panel cutout template has been provided in Appendix B.

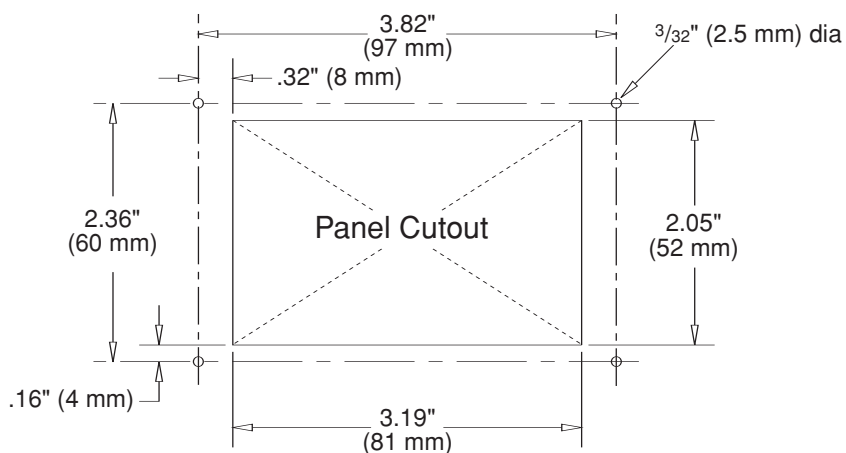

### 2.3.1 Connecting the Antenna Data/Power Cable

1. Connect one end of the antenna data/power cable to the antenna's data/power connector and lock in place (see Figure 2-10).

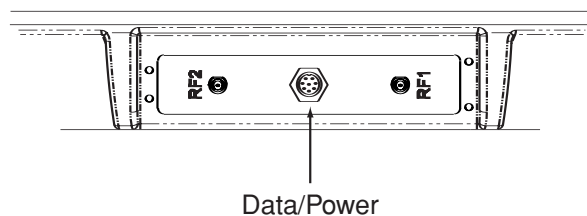

**Figure 2-10**  
Antenna Data/Power Connector

2. Route the other end of the data/power cable down through the cable access hole in the vehicle's roof and out through the switchplate panel cutout.
3. Connect the data/power cable to the switchplate's data/power connector and lock in place (see Figure 2-11).

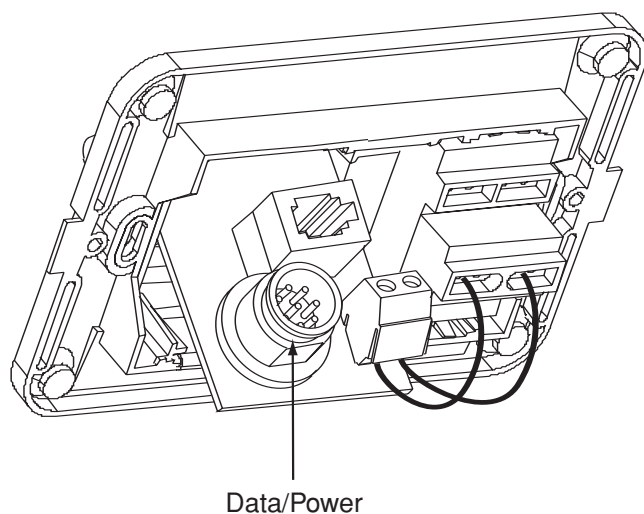

**Figure 2-11**  
Switchplate Data/Power Connector

## 2.3.2 Connecting to Vehicle Power

### Recommended Power Wiring

Short circuits may result in severe electrical shock or burns. Remove the appropriate vehicle fuse and test the circuit to ensure that no power is present before connecting the power cable.

The switchplate requires an 11-16 VDC power input. A quick-tripping circuit breaker or fuse should be installed between the switchplate and vehicle power. Circuit overload protection should be rated for 5 amperes. If vehicle power fluctuates widely or is noisy, a 12 VDC 5-amp AC/DC power supply or a wide-range DC/DC converter power supply should be installed. *Test the voltage and polarity before making connections to vehicle power.*



*Before connecting the antenna unit to vehicle power, remove the appropriate vehicle fuse to prevent a short circuit.*

### Connecting the Power Cable to the Switchplate

1. Disconnect vehicle power by removing the appropriate vehicle fuse.
2. Connect the switchplate to vehicle power as pictured in Figure 2-12.

**Figure 2-12**  
*Switchplate Power Wiring*

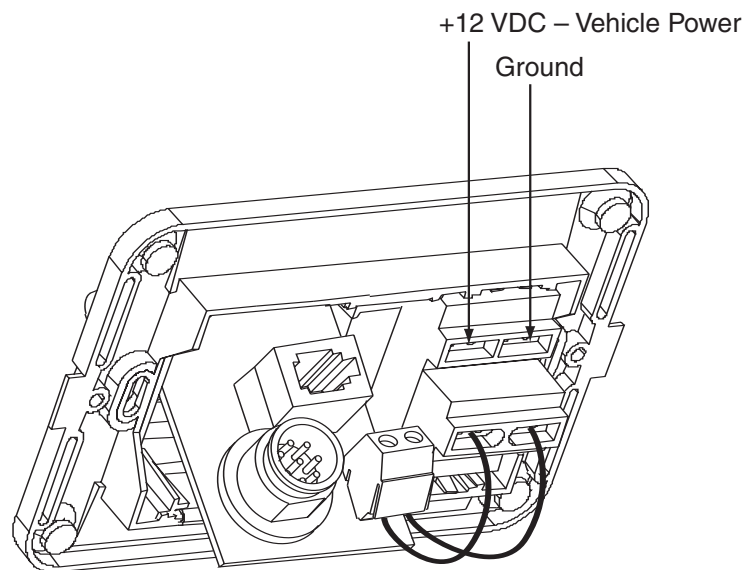

### 2.3.3 Connecting the Receiver Ground Wire

A grounding wire (Cable #32-0583-50) has been provided to connect your receiver to a suitable ground and protect the system. Attach the grounding wire to any suitable screw on the rear panel of the receiver with a good contact with the receiver chassis. The other end should be connected to a suitable ground.

### 2.3.4 Installing the Switchplate

After completing the switchplate wiring process, you must install the switchplate itself. This process, detailed in the following steps, is illustrated in Figure 2-13.

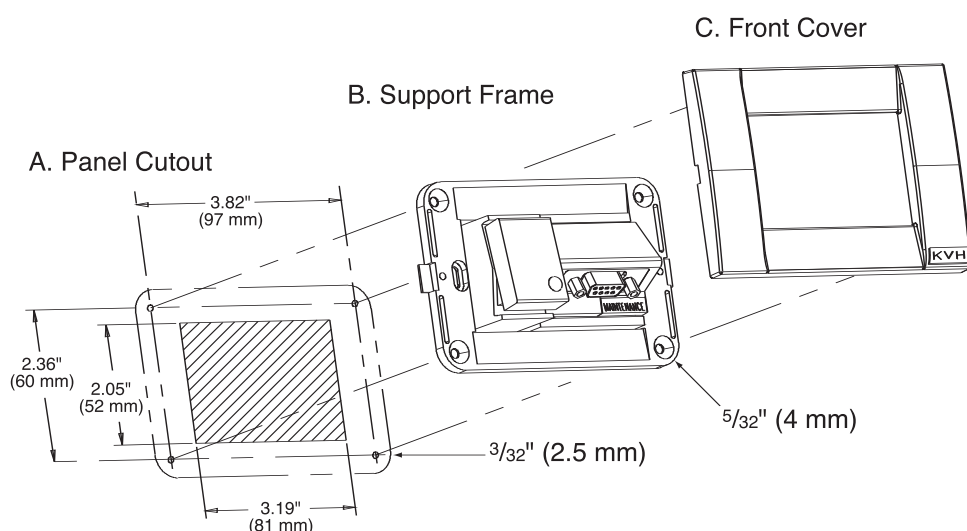

**Figure 2-13**

*Mounting the Switchplate Support Frame and Front Cover*

1. Fit the switchplate assembly and support frame into the panel cutout made in Step 2 of *Section 2.3, "Connecting System Components,"* and flush to the mounting surface.
2. Drill out four  $\frac{5}{32}$ " (4 mm) holes in the countersunk settings in the switchplate support frame.
3. Drill four  $\frac{3}{32}$ " (2.5 mm) holes in the mounting surface using the countersunk holes in the support frame as the template. Secure the support frame and switchplate assembly to the mounting surface using four #6 self-cutting screws.
4. Snap the front cover into place to cover the screws and support frame.
5. Reinstall the vehicle fuse removed in Step 1 of *Section 2.3.2, "Connecting to Vehicle Power."*

*Before securing the switchplate to the mounting surface, be sure to strain-relieve the wires connecting to the switchplate connectors. Several tie-wraps have been provided to aid in strain-relieving the wires.*



When shipped from the factory, the antenna's RF connectors are protected with caps. Leave the cap installed on the RF2 connector unless you are going to connect a second RF cable to the TracVision R5/R4.

**Figure 2-14**

Antenna RF Connectors



KVH recommends the use of RG-6 or RG-11 (75 ohms) cable for RF wiring. Use of non-RG-6 or RG-11 (75 ohms) cables will result in degraded performance. The KVH warranty does not cover degraded performance due to improper wiring.

## 2.3.5 Connecting the Antenna RF Signal Cable to the Receiver

1. Route an RF cable up through the roof's cable access hole.
2. Connect the RF cable to the antenna's RF1 connector (see Figure 2-14). Once the cable is securely connected, loosen the sealing nut at the base of the RF1 connector and tighten it onto the end of the RF cable.

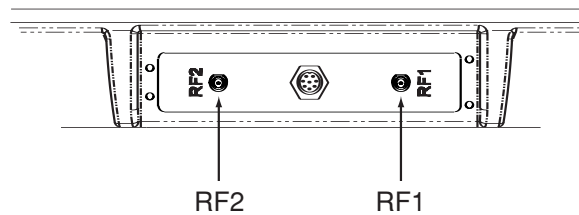

3. Connect the other end of the RF cable to the receiver's SATELLITE IN connector.

### 2.3.5.1 Installing Two Receivers and TVs (North American Systems Only)

To connect a second TV and receiver to the TracVision R5/R4 system, you must connect a second RF cable to the antenna's RF2 connector (see Figure 2-14). Route the other end of the RF cable down into the vehicle and connect it directly to the second receiver.

## 2.3.5.2 Connecting Three or More Receivers and TVs (North American Systems)

To install three or more receiver/TV pairs, an active multiswitch (Channel Master model 6214IFD or equivalent) must be placed between the antenna unit and the receivers. Figure 2-15 illustrates typical wiring arrangements for multiple receivers. If more than four receivers are required, contact KVH for additional wiring instructions. Mount the multiswitch unit in accordance with the manufacturer's instruction sheet.

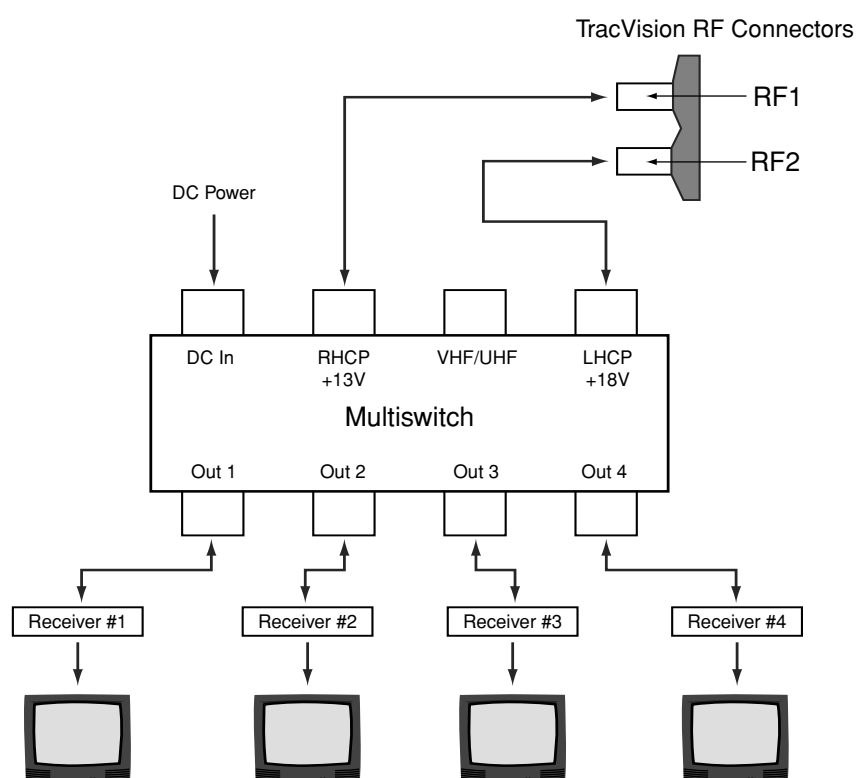

**Figure 2-15**

*Installing Three or Four Receivers Using an Active Multiswitch*



*TracVision R5/R4 has the capability to switch from one satellite to another when you choose TV channels that are carried by your two selected satellites. However, the use of an active multiswitch may interfere with the 22 KHz tone sent by DIRECTV DSS Plus™ receivers to the antenna. In this case, you will need to use the optional TV/SAT Switch\* or a PC as described in Section 3.2, "Changing Channels and Switching Between Satellites."*

*\* To order a TV/SAT Switch (KVH Part Number 01-0245), please call +1 401 847-3327.*

1. Connect the RF cable tagged "RF1" to the multiswitch input labeled "LNB RHCP +13V."
2. Connect a second RF cable to the multiswitch input labeled "LNB LHCP +18V."
3. Connect the multiswitch outputs to individual receiver inputs. Use RG-6 cable terminated with F-type connectors for all RF connections.



4. Terminate all unused output connectors with 75 ohm DC blocks (Channel Master #7184, Radio Shack #15-1259 or equivalent).

### 2.3.6 Sealing the Cable Access Hole

Once the RF and data/power cables are connected to the antenna, you need to seal and cover the cable access hole to protect against leakage.

1. Completely seal the cable access hole with silicone sealant or RTV.
2. Install the clamshell ventilator, supplied in the kitpack, over the cable access hole using the three supplied #6 screws (see Figure 2-16).

**Figure 2-16**

*Installing the Clamshell Ventilator*



Ensure the clamshell mounting screws do not puncture the cables inside the vehicle.

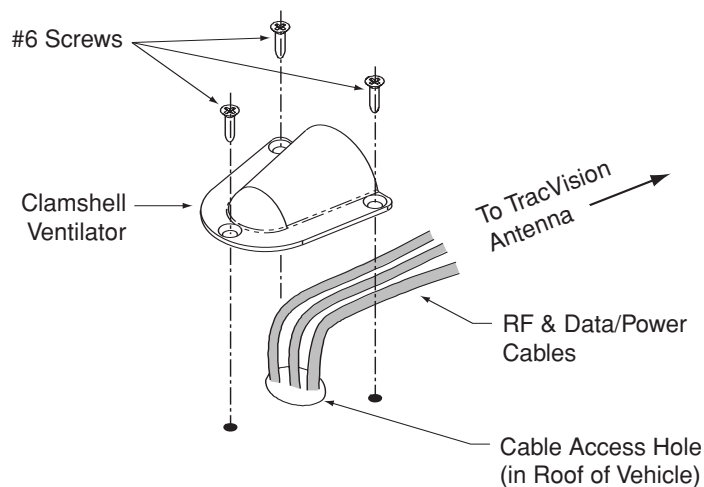

## 2.4 Activating the Receiver

### DIRECTV and DISH Network Receiver Activation

KVH makes it easy to activate your DIRECTV or DISH Network receiver. Just call KVH at 1-888-584-4163 and ask for **Receiver Activation** (Monday - Friday, 8:30 a.m. - 5:00 p.m. ET). For other options, please refer to the user manual that accompanied your receiver.

### Other Receiver Activations

Please refer to the user manual that accompanied your receiver for activation instructions.

## 2.5 Selecting the Active Satellite

As noted previously, TracVision R5/R4 can track a variety of DVB-compatible and DSS (DIRECTV) satellites. The system contains a preprogrammed library of North American and European satellites. It also has two open slots that you may use to program two additional satellites of your choice. Tables 2-3 and 2-4 provide a grid of possible satellite pairs. Two of these satellites may be selected to reside in the system's active memory as Satellites A and B.

**Table 2-3**

*Available N. American Satellite Pairs (U.S.-style LNB Required)*

|           | DSS_101 | DSS_119 | Echo_61 | Echo_110 | Echo_119 | Echo_148 | Expressvu | ExpressTV |
|-----------|---------|---------|---------|----------|----------|----------|-----------|-----------|
| DSS_101   |         | ✓       |         |          |          |          | ✓         | ✓         |
| DSS_119   | ✓       |         |         |          |          |          | ✓         | ✓         |
| Echo_61   |         |         |         | ✓        | ✓        |          | ✓         | ✓         |
| Echo_110  |         |         | ✓       |          | ✓        | ✓        | ✓         | ✓         |
| Echo_119  |         |         | ✓       | ✓        |          | ✓        | ✓         | ✓         |
| Echo_148  |         |         |         | ✓        | ✓        |          | ✓         | ✓         |
| Expressvu | ✓       | ✓       | ✓       | ✓        | ✓        | ✓        |           | ✓         |
| ExpressTV | ✓       | ✓       | ✓       | ✓        | ✓        | ✓        | ✓         |           |

**Table 2-4**

*Available European Satellite Pairs (European LNB Required)*

|          | Astra 1 | Astra 2N | Astra 2S | Hispasat | Hotbird | Sirius | Thor |
|----------|---------|----------|----------|----------|---------|--------|------|
| Astra 1  |         | ✓        | ✓        |          | ✓       | ✓      |      |
| Astra 2N | ✓       |          |          |          | ✓       |        |      |
| Astra 2S | ✓       |          |          |          | ✓       |        |      |
| Hispasat |         |          |          |          |         |        |      |
| Hotbird  | ✓       | ✓        | ✓        |          |         | ✓      |      |
| Sirius   | ✓       |          |          |          | ✓       |        | ✓    |
| Thor     |         |          |          |          |         | ✓      |      |



To receive DISH 500 service, you will need to install the following two satellites:

Echo\_119 & Echo\_110



**The satellite configuration on your receiver must match the satellite setting on the TracVision R5/R4 system.**

Satellite A on the TracVision R5/R4 must be the same satellite as Receiver Alternative 1 (or A, based on your receiver and must be assigned the Receiver DiSEqC 1 setting.\*

Satellite B on the TracVision R5/R4 must be the same satellite as Receiver Alternative 2 (or B, based on your receiver) and must be assigned the Receiver DiSEqC 2 setting.\*

Refer to your receiver user manual for complete instructions for your receiver.

\* DiSEqC settings apply only to European systems.

**Figure 2-17**  
Connecting to the TracVision R5/R4 Maintenance Port

The satellites listed in TracVision R5/R4 satellite library will be sufficient for most users. However, if you wish to install one or two user-defined satellites, proceed to Section 2.5.2, "Programming User-defined Satellites." After configuring the user-defined satellites, return to the satellite installation process in Section 2.5.1, "Installing Your Selected Satellites."

## 2.5.1 Installing Your Selected Satellites

When you first connect to the system, it is preprogrammed with one of the following default satellite assignments:

- Europe: Astra 1 (Sat. A) and Hotbird (Sat. B)
- N. America (US DIRECTV): DSS\_101 (Sat. A) and DSS\_119 (Sat. B)
- N. America (US DISH Network/ExpressVu): Echo\_119 (Sat. A) and Expressvu (Sat. B)

Should you wish to track a different satellite (either from the satellite library or a user-defined satellite), you must instruct the antenna which satellites will be in the active satellite pair.

### Connecting to the TracVision R5/R4 Maintenance Port

To do so, it is necessary to connect a PC to the maintenance port on the front of the switchplate. To configure the antenna, you will need to use the KVH Flash Update Wizard or Windows HyperTerminal. Use the settings appropriate to your application. (You can download the KVH Flash Update Wizard at [www.kvh.com/wizard](http://www.kvh.com/wizard))

1. Connect one end of the PC data cable to the DB9 maintenance port connector on the switchplate. Connect the other end to the serial port to your PC (a 9-pin/25-pin connector adapter may be needed for some PCs).

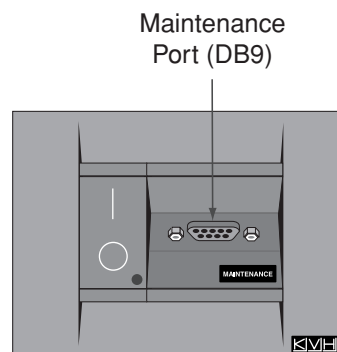

2. If you are using **HyperTerminal**, open HyperTerminal and establish the following settings:

- Bits per second: 9600
- Data bits: 8
- Parity: None
- Stop bits: 1
- Flow control: None

If you are using the **KVH Flash Update Wizard**, double-click the "KVH Flash Update Wizard" shortcut on your computer's desktop to start the wizard. Then go to the "Select board to flash" screen. *You do not need to flash the antenna to configure the satellites; you will simply enter commands in the "Command" box.*

3. Apply power to the TracVision R5/R4 system and allow the system to complete full initialization. Data should be scrolling on the PC display to identify any system problems detected. If no data is seen, recheck your connections and the terminal software setup.

### Installing the Satellite of Choice from the Satellite Library

Once the data connection has been made between the PC and the TracVision R5/R4, you must assign the satellites you wish to have in the satellite pair by typing the following commands. *(If you are using HyperTerminal, type the commands in the HyperTerminal window. If you are using the KVH Flash Update Wizard, type the commands in the "Command" box.)*

1. Type **HALT** and press Enter to place the antenna in Idle Mode.
2. Select which preprogrammed satellites you wish to assign. Table 2-5 lists the satellite names that are in the preprogrammed North American and European satellite library.



KVH Flash  
Update Wizard

**Table 2-5**

*Satellite Installation Names*

| Satellite                              | Install Name |
|--|--------------|
| <b>North American Satellites</b>       |              |
| DSS 101°W                              | DSS_101      |
| DSS 119°W                              | DSS_119      |
| EchoStar 61°W                          | Echo_61      |
| EchoStar 110°W                         | Echo_110     |
| EchoStar 119°W                         | Echo_119     |
| EchoStar 148°W                         | Echo_148     |
| ExpressVu                              | Expressvu    |
| ExpressTV                              | ExpressTV    |
| <b>European Satellites</b>             |              |
| ASTRA1 19.2°E                          | ASTRA1       |
| ASTRA2N 28.2°E                         | ASTRA2N      |
| ASTRA2S 28.2°E                         | ASTRA2S      |
| Hispasat 30.0°W                        | HISPASAT     |
| Hotbird 13.0°E                         | HOTBIRD      |
| Sirius 5.0°E                           | SIRIUS       |
| Thor 0.8°W                             | THOR         |
| <b>Other Installation Designations</b> |              |
| User-defined 1                         | USER1*       |
| User-defined 2                         | USER2*       |
| None                                   | None         |

\* *USER1 and USER2 will only be available if one or two user-defined satellites have been added to the library as detailed in Section 2.5.2, "Programming User-defined Satellites."*

3. Type **SATINSTALL**, **<sat\_a\_name>**, **<sat\_b\_name>** and press Enter. Type **None** as the name of Satellite B if wish to install only one satellite.

---

|      |  |
|------|--|
| Key: | <sat_a_name> = the name of your choice for Satellite A<br><br><sat_b_name> = the name of your choice for Satellite B |
|------|--|

---

4. Type **L,X** and press Enter to select which of these two satellites the antenna should begin tracking.

---

|      |  |
|------|--|
| Key: | X = A or B (one of your selectedd satellites defined during the install process) |
|------|--|

---

5. Type **ZAP** and press Enter to restart the system. Be sure the receiver's satellite configuration matches your chosen TracVision R5/R4 settings.

For example, to assign Astra 2S and Hotbird for your satellite pair, and to track Astra 2S, you would enter the following data:

```
SATINSTALL, ASTRA2, HOTBIRD<ENTER>  
@L, A<ENTER>  
ZAP<ENTER>
```

## 2.5.2 Programming User-defined Satellites

The TracVision R5/R4 satellite library has two open slots that you may use to program two user-defined satellites in case you want to install/watch a satellite that is not in the KVH predefined satellite library. To configure a user satellite, you will need to obtain the following satellite information from your satellite service provider or from sites on the Internet, such as [www.satcodx.com](http://www.satcodx.com):

- Satellite name
- Satellite position (longitude)
- Transponder information for each of the following polarizations/frequencies:
  - vertical high & vertical low
  - horizontal high & horizontal low*or*
  - right
  - left
- Transponder information includes:
  - frequency
  - symbol rate
  - FEC code, and
  - network ID (in hexadecimal format)
- Decoder type



*For your reference, the satellite configuration information for the predefined satellites is available on our web site at [www.kvh.com/footprint](http://www.kvh.com/footprint).*

### Entering User-defined Satellite Data

Once the link between the PC and the TracVision R5/R4 is established as described in *Section 2.5, "Selecting the Active Satellite,"* follow these steps to begin entering the data for your user-defined satellite.

1. Type **HALT** and press Enter to place the antenna in Idle Mode.
2. Type following command and press Enter:

**SATCONFIG,USERX,YYY,Z,D,L<ENTER>**

|      |   |
|------|---|
| Key: | <p>X = 1 or 2 (This represents the first or second user-defined satellite. Your TracVision system allows up to two user-defined satellites.)</p> <p>YYY = longitude (0-180)</p> <p>Z = E (East) or W (West)</p> <p>D = decoding type (0 = test, 1 = DSS-A, 2 = DSS-B, 3 = DVB)</p> <p>L = LNB polarization (C = circular, L = linear)</p> |
|------|---|

The main board has now been configured to recognize the user-defined satellite. Next, the RF Board must be configured.

3. Type **@DEBUGON** and press Enter.
4. Type the following command and press Enter.

**@SATCONFIG,X,N,F,S,C,ID,P,B,D<ENTER>**

|      |  |
|------|--|
| Key: | <p>@SATCONFIG = directs data to the RF Board</p> <p>X = satellite location A or B</p> <p>N = satellite table # (98 &amp; 99 are slots for user-configured satellites)</p> <p>F = frequency in MHz (either 00000 or a range from 10700 - 12700)</p> <p>S = the satellite transponder symbol rate in Mbit/second (01000 - 29999)</p> <p>C = the FEC code (e.g., 12, 23, 34, 56, 67, 78)</p> <p>ID = the satellite network ID in hexadecimal format (0x####)</p> <p>P = the LNB polarization (v = vertical, h = horizontal, r = right, l = left)</p> <p>B = the LNB down conversion frequency (l = low, h = high, u = USA)</p> <p>D = decoding type (0 = test, 1 = DSS-A, 2 = DSS-B, 3 = DVB)</p> |
|------|--|

This information has to be entered for each of the following categories:

- vertical high
- vertical low
- horizontal high
- horizontal low

*or*

- right
- left

TracVision R5/R4 requires that the data fields for all transponder categories be provided. If the selected satellite does not have information for one or more of the transponder categories, default information should be entered in the fields as follows:

| Transponder Data  | Default Value   |
|-------------------|---|
| Frequency         | 00000   |
| Symbol Rate       | 27500   |
| FEC Code          | the same value as provided for those transponders with data |
| Network ID        | 0x0000  |
| Polarity and Band | whichever combinations are not already provided             |

**Table 2-6**

*Default Transponder Values*

5. Type **@SAVE,A** and press Enter to save your settings (or **@SAVE,B** if data is for User2 satellite.)
6. Type **@DEBUGOFF** and press Enter.
7. Type **ZAP** and press Enter to restart the system.

One of your user-defined satellites has now been added to the TracVision R5/R4 satellite library. This satellite will now be available the next time you use the SATINSTALL command.



### An Example of Configuring a User-defined Satellite (Europe)

The following is an example of configuring the fictional YOURSAT 101 as the USER1 configured satellite. Prior to configuring this satellite or any others, be certain to get the most up-to-date information from one of the sources previously discussed.

**Table 2-7**  
*Sample User-defined  
 Satellite Configuration (Europe)*

#### YOURSAT 101 at 71 West, DVB decoder, Circular Polarization LNB

|                        |                     |
|------------------------|---------------------|
| <i>Horizontal High</i> |                     |
| Frequency              | 11.966 GHz          |
| Symbol Rate            | 27500               |
| FEC Code               | 3/4                 |
| Network ID             | 2048 (dec) = 0x0800 |
| <i>Vertical High</i>   |                     |
| Frequency              | 11.823 GHz          |
| Symbol Rate            | 27500               |
| FEC Code               | 3/4                 |
| Network ID             | 2048(dec) = 0x0800  |
| <i>Vertical Low</i>    |                     |
| No Data Listed         |                     |
| <i>Horizontal Low</i>  |                     |
| No Data Listed         |                     |

Based on this information, the data entered via the PC would look like this, assuming that YOURSAT 101 would be Satellite A:

```
SATCONFIG,USER1,7,W,3,L
@DEBUGON
@SATCONFIG,A,98,11966,27500,34,0x0800,H,H,3
@SATCONFIG,A,98,11823,27500,34,0x0800,V,H,3
@SATCONFIG,A,98,00000,27500,34,0x0000,V,L,3
@SATCONFIG,A,98,00000,27500,34,0x0000,H,L,3
@SAVE,A
@DEBUGOFF
ZAP
```

## An Example of Configuring a User-defined Satellite (N. America)

The following is an example of configuring the fictional YOURSAT 101 as the USER1 configured satellite. Prior to configuring this satellite or any others, be certain to get the most up-to-date information from one of the sources previously discussed.

### YOURSAT 101 at 71 West, DVB decoder, Circular Polarization LNB

|              |                     |
|--------------|---------------------|
| <i>Right</i> |                     |
| Frequency    | 11.966 GHz          |
| Symbol Rate  | 27500               |
| FEC Code     | 3/4                 |
| Network ID   | 2048 (dec) = 0x0800 |
| <i>Left</i>  |                     |
| Frequency    | 11.823 GHz          |
| Symbol Rate  | 27500               |
| FEC Code     | 3/4                 |
| Network ID   | 2048(dec) = 0x0800  |

**Table 2-8**

*Sample User-defined  
Satellite Configuration  
(N. America)*

Based on this information, the data entered via the PC would look like this, assuming that YOURSAT 101 would be Satellite A:

```
SATCONFIG,USER1,71,W,3,C
@DEBUGON
@SATCONFIG,A,98,11966,27500,34,0x0800,R,U,3
@SATCONFIG,A,98,11823,27500,34,0x0800,L,U,3
@SAVE,A
@DEBUGOFF
ZAP
```

## 2.6 Setting the Skew Angle (European Systems Only)

The Antenna LNB skew angle must be adjusted to optimize channel reception. Refer to your satellite service provider for the proper skew angle for the selected satellite service and geographical location. The skew angle for satellites in the KVH library can also be obtained by entering your latitude and longitude into the antenna. Determine your grid number in Figure 2-19 to find your corresponding latitude and longitude listed in Table 2-9.

**Figure 2-19**  
Position Grid

**Table 2-9**

Approximate Latitude/Longitude

| Grid # | Latitude | Longitude |
|--------|----------|-----------|
| 1      | 67°N     | 7°W       |
| 2      | 67°N     | 7°E       |
| 3      | 67°N     | 22°E      |
| 4      | 65°N     | 45°E      |
| 5      | 63°N     | 7°W       |
| 6      | 63°N     | 7°E       |
| 7      | 63°N     | 22°E      |
| 8      | 57°N     | 7°W       |
| 9      | 57°N     | 7°E       |
| 10     | 57°N     | 22°E      |
| 11     | 55°N     | 40°E      |
| 12     | 53°N     | 7°W       |
| 13     | 53°N     | 7°E       |
| 14     | 50°N     | 22°E      |
| 15     | 47°N     | 7°W       |
| 16     | 47°N     | 7°E       |
| 17     | 43°N     | 7°W       |
| 18     | 43°N     | 7°E       |
| 19     | 43°N     | 22°E      |
| 20     | 43°N     | 37°E      |
| 21     | 36°N     | 7°W       |
| 22     | 36°N     | 7°E       |
| 23     | 36°N     | 22°E      |
| 24     | 36°N     | 37°E      |

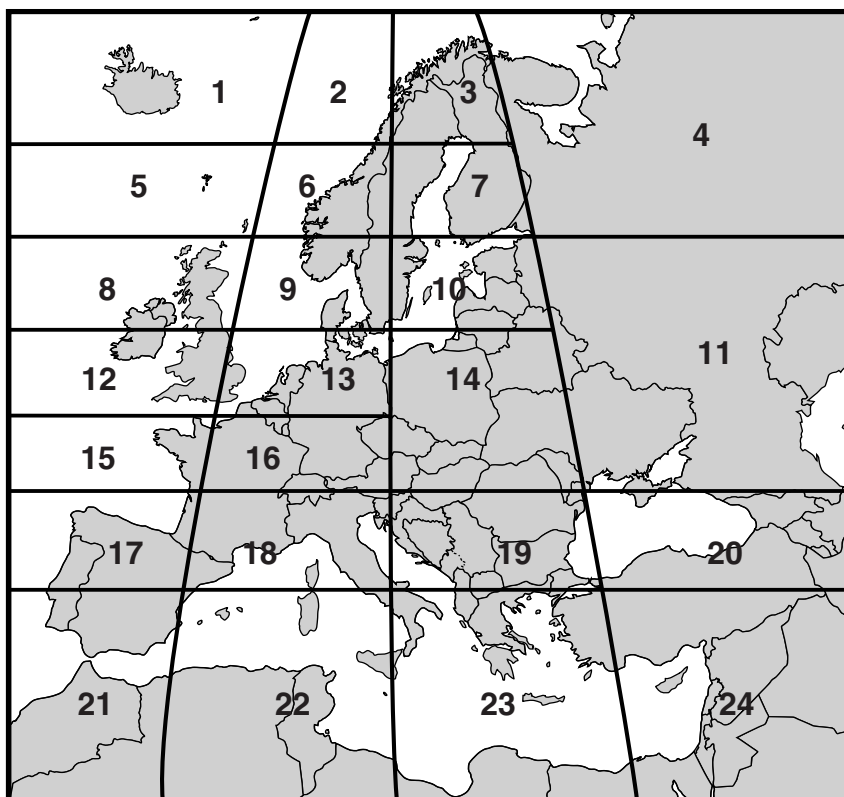

### Finding the Skew Angle for a Predefined Satellite

1. Type **HALT** and press Enter.
2. Type **DEBUGON** and press Enter.
3. Type **GPS,XX,D,YYY,E** and press Enter.

|      |                            |
|------|----------------------------|
| Key: | XX = latitude (0 - 90)     |
|      | D = S (South) or N (North) |
|      | YYY = longitude (0 - 180)  |
|      | E = E (East) or W (West)   |

4. Type **SKEWANGLE** and press Enter. The system will respond with the skew angle for whichever satellite is currently selected.

### Adjusting the LNB Skew Angle

1. Determine the skew angle for the selected satellite and region.
2. Loosen the wing nut on the LNB clamp so that the LNB can be moved.
3. Carefully rotate the LNB so that the scribe mark on the LNB clamp is aligned with the proper angle measurement.
4. Tighten the wing nut and LNB clamp to secure the LNB.

**Figure 2-18**

*Skew Adjustment*

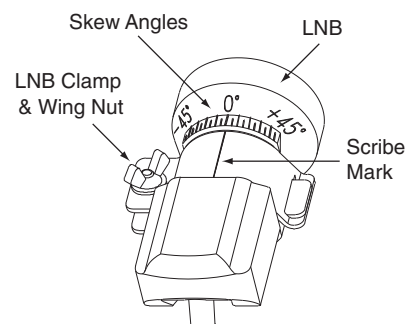

## 2.7 Testing the System

Now all you need to do is turn the system on and ensure everything works properly. Follow the steps below to test the TracVision system.

1. Park the vehicle in a blockage-free area. The antenna requires an unobstructed view of the southern sky to receive satellite signals.
2. Turn on the receiver(s) and TV(s). For instructions on operating the receiver, refer to the receiver's owner's manual.
3. Turn on the TracVision antenna.
4. Within a few minutes, a picture should appear on the TV.
5. (*TracVision R5 only*) Take a road test and verify that the antenna tracks the satellite while the vehicle is moving.
6. When you have finished testing, shut down the system.



If a need arises to paint the radome, **ONLY use non-metallic automotive paint** to avoid degrading the RF signal strength and the reception quality.

## 2.8 Configuring TracVision R5/R4 for Remote Satellite Dish Operation

In some campground locations, dense foliage will block the satellite signal. In these situations, a remote portable antenna may be the only solution to satellite signal reception.

The wiring option for the remote dish is very simple and should be installed when the TracVision R5/R4 is installed. A high-quality "A/B switch" should be used to change from TracVision R5/R4 dish reception to remote antenna operation. The recommended wiring arrangement for remote dish operation is illustrated in Figure 2-20.

**Figure 2-20**  
Remote Dish Wiring Configuration

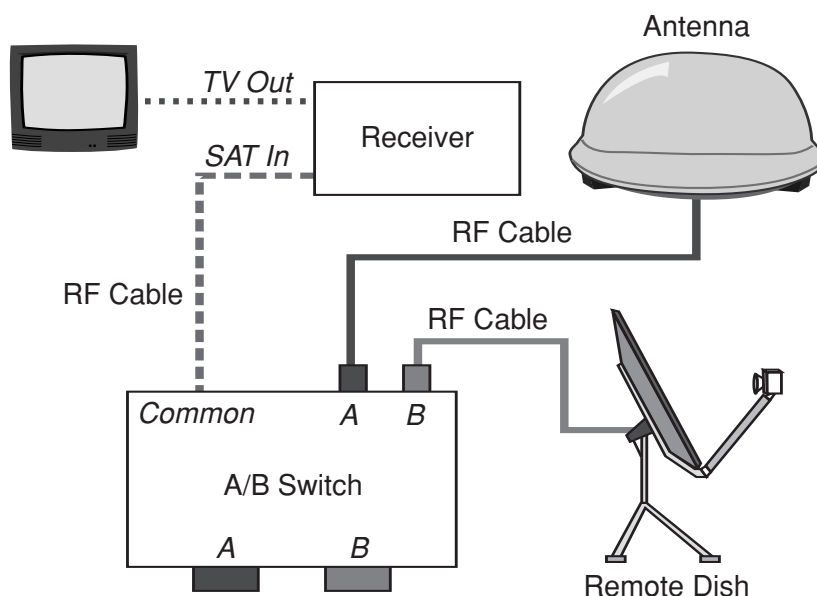

## 2.9 Changing Geographic Location

If you move from Europe to the U.S., or from the U.S. to Europe, you will need to modify your TracVision R5/R4 system to receive satellite TV signals in the new geographic area.

To begin receiving satellite signals in the new area, perform the following steps.

### Swap LNBS

To receive the proper satellite signals in the new geographic location, your TracVision antenna must be equipped with the appropriate LNB for that location. If moving from Europe to the U.S., you will need to install a North American-style LNB. If moving from the U.S. to Europe, you will need to install a European-style LNB. Table 2-10 lists the part numbers for ordering these LNB options.

| Part Name                | Part Number |
|--------------------------|-------------|
| European-style LNB       | 19-0196     |
| North American-style LNB | 19-0056     |

**Table 2-10**

*LNB Part Numbers*

With the new part, you will receive an easy-to-understand instruction sheet for swapping the LNBS.

### Install New Satellites

When you move to a new area, the list of available satellites changes. If you're moving to Europe, you will need to choose a new satellite pair from the list of available European satellites (see Table 2-4). If you're moving to the U.S., you will need to choose a new satellite pair from the list of available North American satellites (see Table 2-3). For details on installing these new satellites, refer to *Section 2.5.1, "Installing Your Selected Satellites."*

### Replace the Receiver

In order to receive satellite TV service in your new geographic location, you will need to purchase a receiver designed for that location. Refer to your satellite TV service provider for more information.



*You may also need to replace your television when changing geographic location. In North America, your TV must support the NTSC video standard. In Europe, your TV must support the PAL video standard.*

## 3 Using Your TracVision R5/R4

For TracVision R5/R4 to receive the satellite signals, the antenna must have a clear line of sight to the satellite. If you only receive intermittent signals or the antenna cannot find the satellite, check around your vehicle for any objects that could be blocking the signal, such as trees, buildings, highway overpasses, etc.



**Figure 3-1**

*Be Aware of Objects that Might Block the Satellite Signals*

You must also be located within the selected satellite's coverage area in order to receive its signal. Refer to your satellite television service manual to check the viable coverage area. *For your convenience, KVH provides links to several web sites that offer satellite coverage information. Simply go to our web site at: [www.kvh.com/footprint](http://www.kvh.com/footprint).*

### 3.1 Turning On the System

The TracVision R5/R4 system is easy to use. Antenna unit initialization and satellite acquisition are completely automatic.

To use the TracVision R5/R4 system:

1. *(TracVision R4 only)* Park your vehicle.
2. Turn on the receiver and television. (Refer to your receiver user manual for complete operating instructions for the receiver.)



*To minimize the time it takes the antenna to acquire the satellite, do not change the channel during the startup process or cable unwrap.*



*The TracVision R4 is for stationary use only.*

**Figure 3-2**

Turning on the TracVision R5/R4  
Using the Switchplate

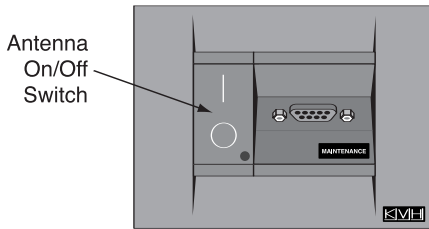

If you are a **DISH 500** customer or you have 3 or more receivers, you can order the optional TV/SAT Switch – **free of charge**. Simply fill out the order form located at the back of this manual and fax it to KVH at +1 401 845-8190.



**The satellite configuration on your receiver must match the satellite setting on the TracVision R5/R4 system.**

Satellite A on the TracVision R5/R4 must be the same satellite as Receiver Alternative 1 (or A, based on your receiver) and must be assigned the Receiver DiSEqC 1 setting.\*

Satellite B on the TracVision R5/R4 must be the same satellite as Receiver Alternative 2 (or B, based on your receiver) and must be assigned the receiver DiSEqC 2 setting.\*

Refer to your receiver user manual for complete instructions for your receiver.

\* DiSEqC applies to European systems only

3. Turn on the antenna using the switchplate, as pictured in Figure 3-2.
4. (TracVision R5 only) If the vehicle is moving, avoid turning the vehicle for 60 seconds after turning on the antenna to allow the antenna gyro to initialize properly.

## 3.2 Changing Channels and Switching Between Satellites

If you have followed the installation instructions, your system should be set to the active satellite pair of your choice and the system should have downloaded the appropriate channel guides. You must also have a properly configured receiver (if this has not been done, refer to your receiver User's Manual for instructions for your specific receiver).

Your TracVision system is programmed to track either of two satellites, stored in memory as Satellite A and Satellite B. You can use the receiver remote control, the optional TV/SAT Switch\*, or a PC to select between the two satellites. Some DISH 500 customers may also use the DISH 500 mode, which allows automatic switching between the Echo 119 and Echo 110 satellites (see Section 3.4, "DISH 500 Mode").

\* To order a TV/SAT Switch (KVH Part Number 01-0245), please call +1 401 847-3327.

### 3.2.1 Using the Receiver Remote Control to Switch Between Satellites

#### Europe

When the TracVision R5/R4 system and the receiver have matching configurations, switching from one satellite to the other is as easy as changing the channel using the remote control. TracVision R5/R4 will automatically switch from Satellite A to B and back again as necessary to receive your selected channel.



## North America

### DIRECTV Subscribers

DIRECTV subscribers in certain regions of the United States will require a DSS Plus receiver to receive broadcasts from multiple satellites. If connected to the antenna's RF1 connector, the DSS Plus receiver allows you to switch channels using the remote control. If you are a DIRECTV subscriber, but do not have a DSS Plus receiver, or you are using a multiswitch, use the optional TV/SAT Switch or a PC, as described in the following sections.

### DISH Network Subscribers

Most DISH Network customers will need to manually change satellites using the optional TV/SAT Switch or a PC, as described in the following sections.

*DISH Network customers with DISH 500 service and a DishPro 301 receiver may also use DISH 500 mode. DISH 500 mode automatically switches between the Echo 119 and Echo 110 satellites when the channel is changed using the receiver's remote control. To configure your TracVision R5/R4 for this feature, go to Section 3.4, "DISH 500 Mode."*

### ExpressVu Subscribers

ExpressVu customers can use the optional TV/SAT Switch or a PC, as described in the following sections.

## 3.2.2 Using the TV/SAT Switch to Switch Between Satellites - *Optional*

If you're unable to switch between satellites using the receiver remote control, you can use the optional TV/SAT Switch\* (see Figure 3-3) to easily select between Satellite A and Satellite B.

\* To order a TV/SAT Switch (KVH Part Number 01-0245), please call +1 401 847-3327.

### TV/SAT Switch Controls and Indicators

The Select button is used for all operator controls. The TV/SAT Switch also has three LED indicators that show its current status. Table 3-1 on the following page explains the function of each indicator.

**Figure 3-3**  
TV/SAT Switch

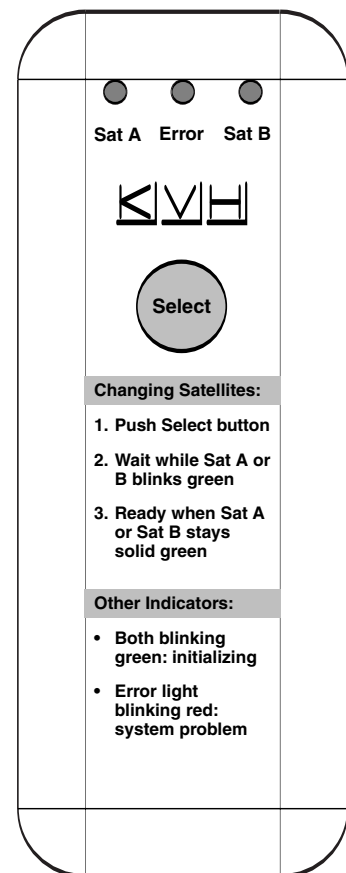

**Table 3-1**  
TV/SAT Switch LED Indicators

| Indicator | Status         | Meaning   |
|-----------|----------------|---|
| Sat A     | Blinking green | Wait – Searching for satellite  |
|           | Solid green    | Tracking Satellite A  |
| Error     | Blinking red   | System problem – <i>Refer to Section 4, “Troubleshooting,” to find the possible cause</i> |
| Sat B     | Blinking green | Wait – Searching for satellite  |
|           | Solid green    | Tracking Satellite B  |

### Connecting the TV/SAT Switch

To use the TV/SAT Switch, you must first connect it to the TracVision system.

1. Connect the TV/SAT Switch’s data cable to the maintenance port on the switchplate (see Figure 3-4).

**Figure 3-4**  
Switchplate Maintenance Port

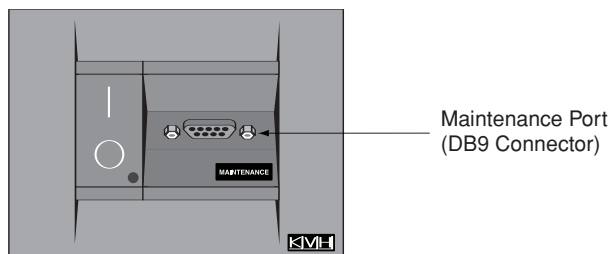

2. The Sat A and Sat B indicators blink while the system initializes.
3. Either the Sat A or Sat B indicator will turn solid green, denoting which satellite is currently being tracked.

### Using the TV/SAT Switch

The TV/SAT Switch is very easy to use. All operations are controlled through a single button.

To select the second satellite, perform the following steps:

1. Press the Select button on the TV/SAT Switch.
2. The indicator for the current satellite (Sat A or Sat B) extinguishes, while the indicator for the other satellite starts blinking.
3. Once the indicator for the other satellite turns solid green, the TracVision system is tracking the newly selected satellite. You can now use your receiver to choose a channel on the new satellite.

### 3.2.3 Using a PC to Switch Between Satellites

If you're unable to switch between satellites using the receiver remote control, you can use a PC connected to the switchplate's maintenance port to select between Satellite A and Satellite B. The procedure requires a PC with Windows HyperTerminal or download the KVH Flash Update Wizard (available for free at [www.kvh.com/wizard](http://www.kvh.com/wizard)).

To switch satellites using a PC, perform the following steps:

1. Connect one end of the PC data cable to the maintenance port on the switchplate (see Figure 3-5). Connect the other end to the serial port on your PC (a 9-pin/25-pin connector adapter may be needed for some PCs).

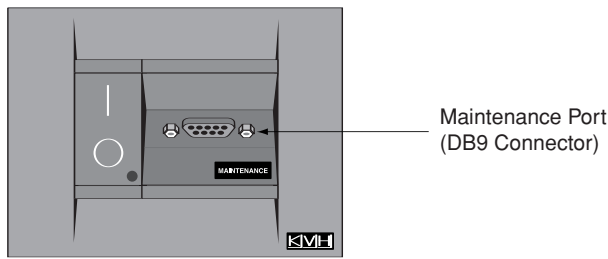

2. If you are using HyperTerminal, open **HyperTerminal** and establish the following settings:
  - Bits per second: 9600
  - Data bits: 8
  - Parity: None
  - Stop bits: 1
  - Flow control: None

If you are using the **KVH Flash Update Wizard**, double-click the "KVH Flash Update Wizard" shortcut on your computer's desktop to start the wizard. Then go to the "Select board to flash" screen. *You do not need to flash the antenna to configure the satellites; you will simply enter commands in the "Command" box.*



*If you are a **DISH 500** customer, you can order the optional TV/SAT Switch – **free of charge**. Simply fill out the order form located at the back of this manual and fax it to KVH at +1 401 845-8190. Please take advantage of this free offer to make satellite switching a breeze!*

**Figure 3-5**

*Switchplate Maintenance Port*

3. Type **@L,X** and press Enter once the data connection is made.

|      |  |
|------|--|
| Key: | X = A or B (whichever satellite you want to track) |
|------|--|

To select Satellite A, type **@L,A** and press Enter.

To select Satellite B, type **@L,B** and press Enter.

4. The antenna unit shifts to track the second satellite.

## 3.3 Watching Television

TracVision R5 is designed to operate whether your vehicle is in motion or parked. TracVision R4 is designed to operate only while your vehicle is parked.

### Using Your TracVision R5/R4 When Parked



(TracVision R5 only) *Don't forget to turn the system back on before you start driving again. The antenna must be turned on to track the satellite while you are moving.*

When your vehicle is stopped, it is not necessary for the TracVision R5/R4 to be turned on. After parking your vehicle and confirming that the antenna is receiving the satellite signal, you may turn off the TracVision R5/R4 unit to avoid unnecessary use of power. Because the LNB receives its power from the receiver, the antenna will continue to receive the satellite TV signals and relay them to the receiver.

However, if you plan to change to a channel that is broadcast by another satellite, TracVision R5/R4 must be turned on so the antenna can search for, identify, and lock onto the different satellite.

### Cable Unwrap

The antenna unit can rotate a full 720° before coming to the end of its cable. If it does so, the system automatically unwraps the cable by quickly rotating the dish in the opposite direction. During this process, your television transmission will be frozen momentarily while the cable unwraps and the antenna reacquires the satellite.

### Sleep Mode (*TracVision R5 only*)

When the vehicle has come to a stop and the antenna holds its position for 1 minute, the antenna unit enters Sleep Mode, which turns off the conical scan tracking, reducing any motor noise the antenna may be making. As soon as the vehicle moves, Sleep Mode will automatically be turned off and the system will begin tracking the satellite again. This convenient feature is ideal for when a vehicle is parked for a short time or idling and passengers want to watch TV.

KVH recognizes that some customers may not want to take advantage of this convenient feature. In this case, it is possible to disable Sleep Mode using a simple software command as follows:

1. Connect a laptop computer to the system using the maintenance port and use the KVH Flash Update Wizard or HyperTerminal, as described in *Section 2.5.1, "Installing Your Selected Satellites."*
2. Turn on the antenna. When the limit switch test is complete:
  - a. Type **HALT** and press Enter.
  - b. Type **DEBUGON** and press Enter.
  - c. Type **SLEEPOFF** and press Enter.
3. Turn the antenna off by pressing its power button.
4. Wait 30 seconds and press the antenna's power button to turn the antenna back on. Sleep Mode is now disabled. *To reactivate Sleep Mode, follow this same process, typing **SLEEPON** instead of SLEEPOFF during Step c.*

### Conical Scan Tracking (*TracVision R5 only*)

The antenna control unit uses conical scanning to maintain peak signal strength to the receiver and to update the satellite's position. When conical scan tracking is active, the antenna moves continually with a circular motion to sweep across the satellite's peak signal. The signal strength is then fed back to the control circuits to keep coming back to the direction of the strongest signal.



*Unlike turning the power off, the antenna will still be operational and drawing power when in Sleep Mode. If you are going to be parked for an extended period of time, turning off the antenna will conserve power while still allowing you to receive the TV signals.*

If the satellite signal is lost while the system is in conical scan track mode, the control software imposes a 45-second time-out delay. If the signal is not regained during that time, the antenna reverts to the set of Search Modes to start looking for the satellite signal. This is an automatic process that does not require user intervention.



## 3.4 DISH 500 Mode

DISH Network customers with DISH 500 service **and** a DishPro 301 receiver may configure the TracVision R5/R4 system to use DISH 500 mode. DISH 500 mode automatically switches between the Echo 119 and Echo 110 satellites when the channel is changed using the receiver's remote control.

### Configuring the Antenna for DISH 500 Mode

To configure the TracVision antenna for DISH 500 mode, you will need to run the receiver's Check Switch function twice. You do **not** need a laptop computer.

To configure the TracVision antenna for DISH 500 mode, follow the steps below.

1. Park your vehicle in a blockage-free area and do not move the vehicle until you have completed the entire configuration process.
2. Turn on the master receiver (*the receiver that is connected to the antenna's RF1 connector*) and the television.
3. Turn on the TracVision antenna using the switchplate's power switch.
4. Wait one minute for the antenna to initialize.
5. Using the receiver's remote control, go to the "Point Dish/Signal Strength" screen (*press Menu, 6, 1, 1 (on most models)*).
6. Using the remote control's arrow buttons, highlight "Check Switch" and press the Select button.
7. Highlight "Test" and press Select.

8. Wait a minimum of **15 minutes** for the Check Switch function to complete and for the antenna to restart and configure itself for DISH 500 mode.

*If the Check Switch function fails (the receiver locks up), disconnect power from the receiver, restart the antenna, then restore power to the receiver and try the Check Switch function again.*

9. Run the Check Switch function a second time. This allows the receiver to configure itself for automatic satellite switching.
10. Wait until the Check Switch function is complete (*it will take a couple minutes*).
11. Ensure that the following is displayed on the TV:

|                               |                                     |             |            |             |
|-------------------------------|-------------------------------------|-------------|------------|-------------|
| Installed Switch: <b>SW42</b> |                                     |             |            |             |
| Input:                        | <b>1</b>                            | <b>1</b>    | <b>2</b>   | <b>2</b>    |
| Satellite:                    | <b>119</b>                          | <b>119</b>  | <b>110</b> | <b>110</b>  |
| Polarity:                     | <b>Odd</b>                          | <b>Even</b> | <b>Odd</b> | <b>Even</b> |
| Status:                       | <b>Satellite reception verified</b> |             |            |             |

**Figure 3-6**  
Check Switch Screen

This indicates that the receiver is configured properly. If this information is not displayed **exactly** as shown above, try running the Check Switch function again.

12. Exit the menu and allow the receiver to download the program guide.
13. Once the program guide has loaded, you can start enjoying satellite TV. The antenna will now switch between satellites automatically as you change channels using the receiver's remote control.

# 4 Troubleshooting

The troubleshooting matrix shown in Table 4-1 identifies some trouble symptoms, their possible causes, and references to troubleshooting solutions.

**Table 4-1**  
Troubleshooting Matrix

| SYMPTOM                                   | POSSIBLE CAUSE (AND SOLUTION)                 |   |  |   |  |  |  |  |                                     |                                 |                                |                                    |                                  |
|---|---|---|--|---|--|--|--|--|-------------------------------------|---------------------------------|--------------------------------|------------------------------------|----------------------------------|
|   | Blown fuse or improper wiring (Section 4.1.1) | Incorrect satellite configuration (Section 4.1.2) | Satellite signal blocked (Section 4.1.2) | Dew or rain pooling on dome (Section 4.1.3) | Satellite coverage issue (Section 4.1.4) | Vehicle turning during startup (Section 4.1.5) | Incorrect or loose RF connectors (Section 4.1.6) | Type of multiswitch used (Section 4.1.7) | Stationary use only (Section 4.1.8) | Receiver wiring (Section 4.1.9) | Receiver fault (Section 4.2.1) | Antenna gyro fault (Section 4.2.2) | LNB assembly fault (Section 4.3) |
| Antenna non-functional                    | X   |   |  |   |  |  |  |  |                                     |                                 |                                |                                    |                                  |
| Antenna not switching channels/satellites |   | X   |  |   |  | X  |  |  |                                     |                                 |                                |                                    |                                  |
| No picture on TV set                      |   |   |  | X   | X  | X  | X  |  | X                                   | X                               | X                              |                                    | X                                |
| Intermittent picture for short intervals  |   | X   | X  | X   | X  | X  |  | X  | X                                   | X                               | X                              | X                                  | X                                |
| System works at rest but not on the move  |   | X   |  |   |  |  |  | X  |                                     |                                 | X                              |                                    |                                  |
| System will not find satellite            |   | X   | X  | X   | X  | X  |  |  | X                                   |                                 |                                | X                                  | X                                |
| Snowy television picture                  |   |   |  |   |  |  |  |  | X                                   |                                 |                                |                                    |                                  |
| Picture jumbled, parts missing, freezing  |   |   | X  | X   |  |  |  |  |                                     |                                 |                                |                                    |                                  |
| TV/SAT Switch Error LED blinking          |   |   |  |   |  | X  |  |  | X                                   | X                               | X                              |                                    | X                                |

## 4.1 Causes and Remedies for Common Operational Issues

There are a number of common issues that can affect the signal reception quality or the operation of the TracVision R5/R4. The following sections address these issues and potential solutions.



### 4.1.1 Blown Fuse or Improper Wiring

If the antenna unit is installed but entirely non-responsive, there are three key factors to check as part of the troubleshooting process:

1. Blown Fuse – The antenna unit is equipped with two fuses mounted on its CPU Board. If either of these fuses has blown or been broken, the antenna unit will not operate. Refer to *Section 5.4.1, "PCB Removal and Replacement,"* for details on the fuse locations and how to access the CPU Board.
2. Wiring – If the system has been improperly wired, the antenna unit will not operate correctly. Refer to *Section 2.3, "Connecting System Components,"* for complete system wiring information.

### 4.1.2 Incorrect Satellite Configuration

The satellite configuration on your receiver must match the satellite setting on the TracVision R5/R4 system.

- Satellite A on the TracVision R5/R4 must be the same satellite as Receiver Alternative 1 (or A, based on your receiver) and must be assigned the Receiver DiSEqC 1 setting.\*
- Satellite B on the TracVision R5/R4 must be the same satellite as Receiver Alternative 2 (or B, based on your receiver) and must be assigned the Receiver DiSEqC 2 setting.\*

\* *The DiSEqC settings only apply to European systems.*

Refer to your receiver user manual for complete instructions on configuring your receiver.

### 4.1.3 Satellite Signal Blocked

Satellite signals can be blocked or degraded by trees and branches, buildings, mountains, overpasses, or equipment on the vehicle itself. Refer to *Section 2.1, "Choosing the Best Location,"* to make certain that the TracVision R5/R4 unit is in the optimal location. Simply moving the vehicle to clear an external obstruction will also restore signal quality.

### 4.1.4 Dew or Rain Pooling on Dome

Dew or rain can occasionally pool on the top of the radome. While this moisture will usually be dispersed when the vehicle is in motion, it can disrupt the signal while the vehicle is at rest. This issue can be minimized with two approaches:

1. Spray the dome with hosed water to remove the dew from the dome surface.
2. Periodically apply liquid dish detergent to the dome surface. Wipe the full-strength detergent on the dome and allow it to dry. This treatment will provide a film that will help moisture roll off the dome.

### 4.1.5 Satellite Coverage Issue

TracVision R5/R4 will provide outstanding reception throughout the entire coverage area for your satellite television service of choice. However, signal quality can be degraded as you approach the fringe coverage areas. Refer to your satellite television service manual to check the viable coverage area.



*For your convenience, KVH provides links to several web sites that offer satellite coverage information. Simply go to our web site at [www.kvh.com/footprint](http://www.kvh.com/footprint).*

### 4.1.6 Vehicle Turning During Startup (TracVision R5 only)

If the vehicle turns during the 60-second startup and initialization sequence that occurs immediately after turning on the power to the TracVision R5 unit, the antenna gyro will record that variable motion as “standing still.” This may cause the antenna to track improperly. To solve this problem, turn TracVision R5 off for at least 10 seconds. Turn the system back on, making certain that the vehicle is either motionless or traveling in a straight line for the 60 seconds immediately following power-up.

### **4.1.7 Incorrect or Loose RF Connectors**

As part of preventive maintenance (described in *Section 5, "Maintenance"*) KVH recommends checking the antenna unit cable connections. A loose RF connector can reduce signal quality. In addition, if you are unable to switch to the other programmed satellite, make sure that you have connected your RF signal cable to the antenna baseplate connector labeled "RF1" (see *Section 2.3.5, "Connecting the Antenna RF Signal Cable to the Receiver"*).

### **4.1.8 Type of Multiswitch Used (North American Systems Only)**

An active multiswitch must always be used to connect the TracVision R5/R4 system to multiple receivers. Refer to *Section 2.3.5, "Connecting the Antenna RF Signal Cable to the Receiver,"* for directions on proper multiswitch/multiple receiver cabling.



*KVH offers an upgrade kit (KVH Part #02-1026) that adds in-motion tracking capability to the TracVision R4, allowing you to receive satellite signals while on the move.*

### **4.1.9 Stationary Use Only (TracVision R4 only)**

The TracVision R4 antenna was designed for stationary use only. As such, the antenna will track the desired satellite while your vehicle is parked, but not while the vehicle is in motion.

## **4.2 Receiver Troubleshooting**

The receiver that was provided with your satellite television service may also be the cause of less-than-ideal operation.

### **4.2.1 Receiver Wiring**

Refer to *Section 2.3.5, "Connecting the Antenna RF Signal Cable to the Receiver,"* and your receiver user manual to confirm that the receiver is properly connected to the antenna unit and the television.

### **4.2.2 Receiver Faulty**

In the case of a faulty receiver, refer to your receiver user manual for service, replacement, and warranty information.

## 4.3 Antenna Gyro and LNB Faults

Section 5, "Maintenance," provides detailed instructions for authorized service personnel who may be required to replace TracVision R5/R4 components. *The TracVision R4 does not include an antenna gyro.*

## 4.4 Computer Diagnostics

TracVision R5/R4 has been designed to provide diagnostic readouts on a PC with a RS-232 serial communication port. If you are unable to isolate a system problem with the foregoing troubleshooting tools, set up a laptop to carry out computer diagnostics as described below. System problems should be found somewhere through the diagnostic readouts.

The procedure requires a PC with Windows HyperTerminal or download the KVH Flash Update Wizard (available for free at [www.kvh.com/wizard](http://www.kvh.com/wizard)).

1. Connect one end of the PC data cable to the maintenance port on the switchplate (see Figure 3-5). Connect the other end to the serial port on your PC (a 9-pin/25-pin connector adapter may be needed for some PCs).
2. If you are using **HyperTerminal**, open it and establish the following settings:
  - Bits per second: 9600
  - Data bits: 8
  - Parity: None
  - Stop bits: 1
  - Flow control: None

If you are using the **KVH Flash Update Wizard**, double-click the "KVH Flash Update Wizard" shortcut on your computer's desktop to start the wizard. Then go to the "Select board to flash" screen. *You do not need to flash the antenna to configure the satellites; you will simply enter commands in the "Command" box.*



3. Apply power to the TracVision R5/R4 system and allow the system to complete full initialization. Data should be scrolling on the PC display to identify any system problems detected. If no data is seen, recheck your connections and the terminal software setup.

# 5 Maintenance

## 5.1 Warranty/Service Information

For information on KVH warranty, repair, and liability policies, please refer to the complete warranty statement provided with your KVH product. If you have any questions, please call your local authorized dealer/installer or distributor, or contact KVH or KVH Europe directly.

## 5.2 Preventive Maintenance

TracVision R5/R4 requires minimal preventive maintenance. The following tasks are sufficient to maintain peak performance.

### Monthly

- Wash the exterior of the radome and baseplate assembly with fresh water; a mild detergent may be added to remove grime. Do not spray the radome directly with high-pressure water.
- Do not apply abrasive cleaners or volatile solvents such as acetone to the ABS radome.

### Annually

- Remove the radome and examine the interior of the antenna unit for signs of corrosion, loose connections, or frayed or broken wires.
- Visually inspect the elevation drive shaft to be certain that it moves easily and is clear of grit and debris.



*When cleaning the radome, avoid any compounds that react with plastic.*



The serial number of your TracVision R5/R4 will be required during any troubleshooting or service calls. You will find the serial number at the front of this manual.

## 5.3 Replaceable Parts

TracVision R5/R4 has been designed with durability and low maintenance in mind. If you experience an operating problem or otherwise require technical assistance, contact your local authorized TracVision R5/R4 dealer/distributor first. Have the antenna unit serial number ready with a list of the trouble symptoms. If an authorized dealer/distributor is not located nearby, contact the factory directly at the telephone, facsimile, or e-mail listings inside the front cover.

Replacement part numbers for units that can be serviced in the field are listed in Table 5-1. These parts may be obtained from any KVH authorized dealer/distributor.

**Table 5-1**  
Field Replaceable Units

| Part Name   | Part Number                 |
|---|-----------------------------|
| Baseplate Assembly ( <i>TracVision R5</i> )       | 02-1245-01*<br>02-1245-03** |
| Baseplate Assembly ( <i>TracVision R4</i> )       | 02-1245-02*<br>02-1245-04** |
| Radome Assembly ( <i>TracVision R5</i> )          | 02-0953-03†                 |
| Radome Assembly ( <i>TracVision R4</i> )          | 02-0953-05†                 |
| Data/Power Cable                                  | 32-0730-28                  |
| RF Cable  | 32-0417-28                  |
| PC Cable  | 32-0628-06                  |
| CPU PCB   | 02-1043-02                  |
| RF PCB  | 02-1342                     |
| Antenna Gyro ( <i>TracVision R5 only</i> )        | 02-1035                     |
| Antenna Gyro Gasket ( <i>TracVision R5 only</i> ) | 24-0139                     |
| System Fuses                                      | 16-0017-3150                |
| LNB (European System)                             | 19-0346                     |
| LNB (N. American System)                          | 19-0056                     |
| Switchplate                                       | 02-1023-01                  |
| TV/SAT Switch ( <i>optional</i> )                 | 01-0245                     |



Should a fuse ever need to be replaced, TracVision R5/R4 uses two 5x20 mm, 3.15-amp, 250-volt fast-blow fuses.



To help us continually improve the quality and reliability of our systems, please return any failed component to KVH or KVH Europe (care of the mailing address listed at the front of this manual) after you receive your replacement part.

\* Baseplate assembly with single-output LNB

\*\* Baseplate assembly with dual-output LNB

† Specify color when ordering

It is recommended that all other technical difficulties be resolved by returning the TracVision R5/R4 unit to an authorized service provider.

## 5.4 Field Replaceable Unit Procedures

The following subsections provide detailed procedures for repairing or swapping out field replaceable units. The procedures refer to labeled items presented on the following diagrams.

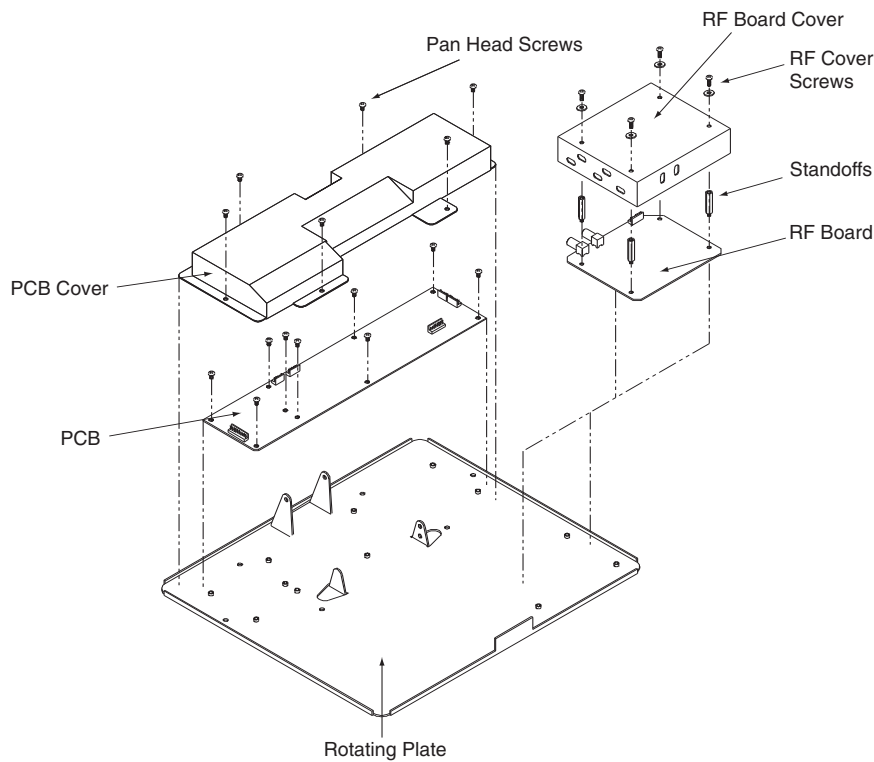

**Always lift the antenna unit by the gray baseplate, never by the radome or any portion of the antenna assembly!**

**Figure 5-1**  
Antenna, PCB, and Rotating Plate



Before servicing the antenna unit, be sure to remove the appropriate vehicle fuse to disconnect power. Replace the fuse after completing the service.

**Figure 5-2**  
Close-up of Connecting Rod and E-ring

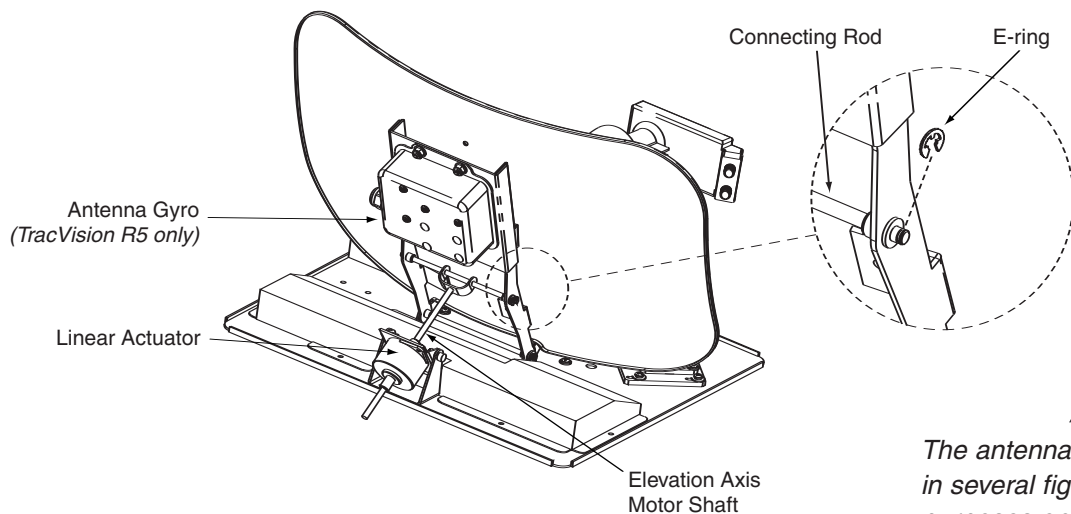

The antenna reflector is not shown in several figures for clarity purposes only. **Do not remove the antenna reflector!**



**Figure 5-3**  
Antenna Assembly

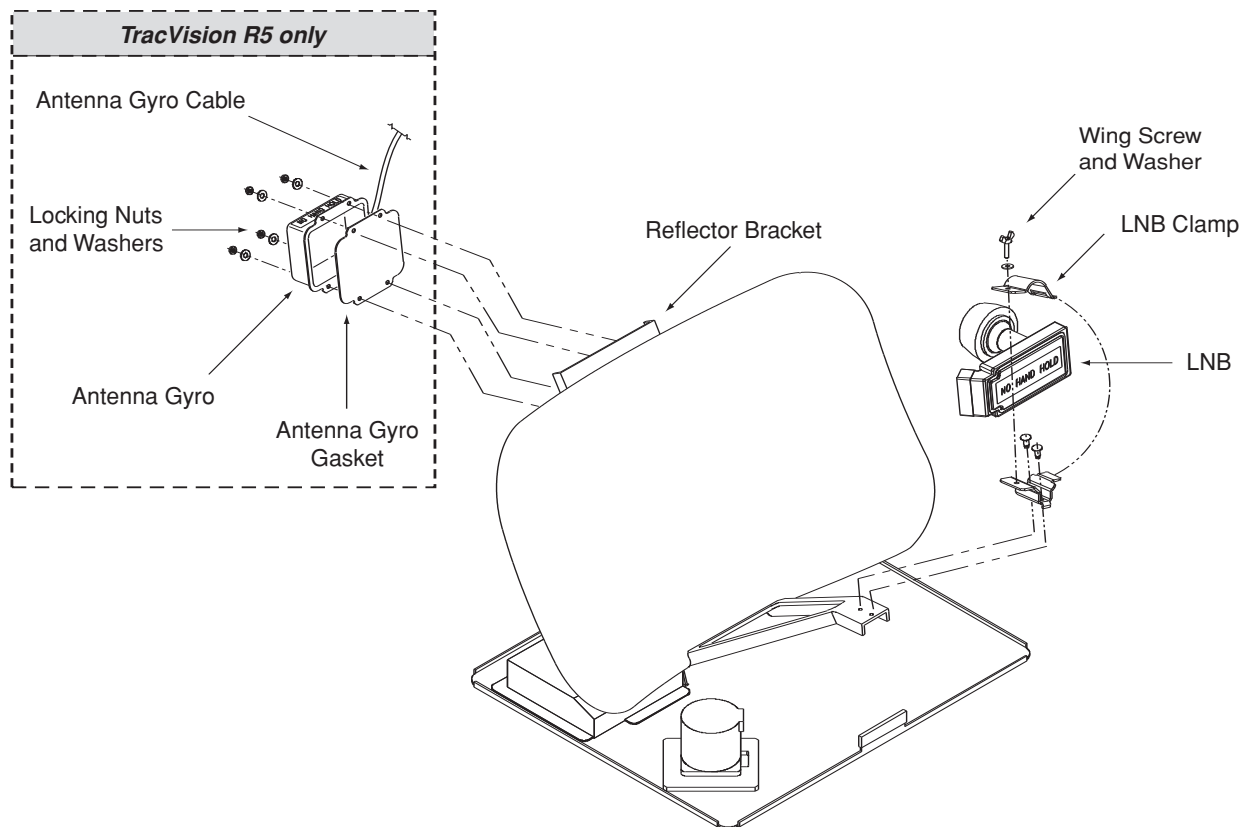

**Figure 5-4**  
Close-up of RF Detector and PCB

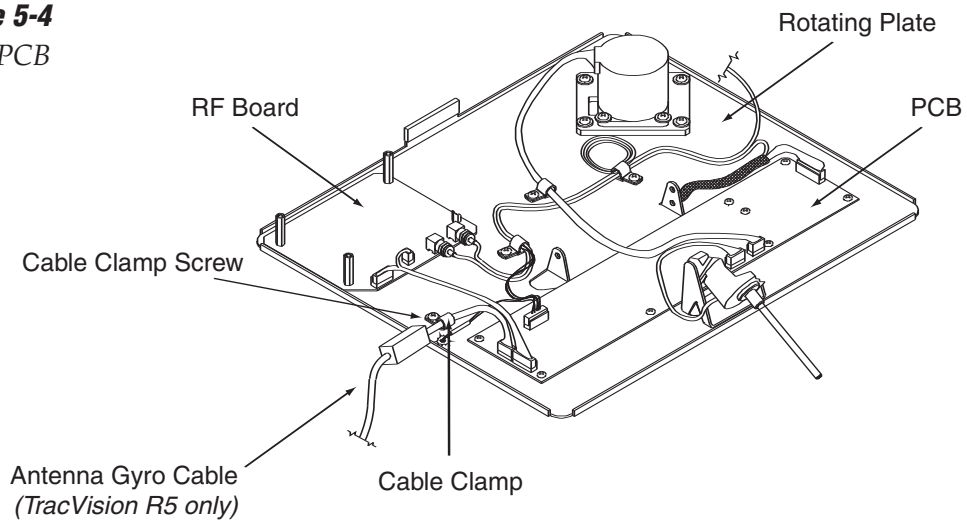

## 5.4.1 PCB Removal and Replacement

**Estimated Time to Repair:** ½ hour

The microprocessor PCB assembly is protected by a cover fastened to the rotating plate – Fig. 5-1. The cover must be removed to gain access to the main power fuses and the PCB assembly.

1. Using needle-nose pliers, remove the E-ring from one end of the connecting rod – Fig. 5-2.
2. Remove the connecting rod by sliding it off the bracket.
3. Fully retract the elevation axis motor shaft – Fig. 5-5.

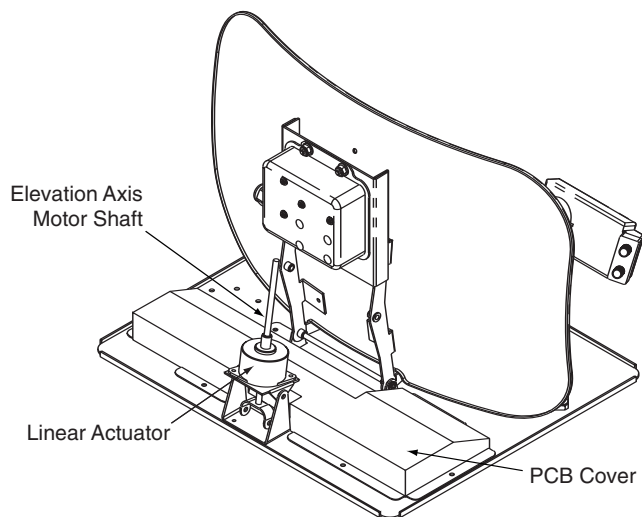

4. Remove 6 pan head screws from the PCB cover flanges.
5. Remove the PCB cover. To get the necessary clearance, rotate the linear actuator up 90° while lifting the PCB cover – Fig. 5-5.
6. Remove all cable connectors from the PCB. Figure 5-6 on the following page illustrates the PCB arrangement and connector locations.



*When carrying out maintenance on the PCB, be sure to not drop any of the small screws inside the mechanism. If a screw is lost within the baseplate, it **must** be retrieved to avoid causing any damage when the unit rotates.*

**Figure 5-5**

*Removing the PCB Cover*



*TracVision R5/R4 is equipped with two 5x20 mm, 3.15-amp, 250-volt fast-blow fuses, which are mounted on the PCB. To access and replace one of the fuses, remove the PCB cover.*

**Figure 5-6**  
PCB and RF Detector Board  
Connector Locations

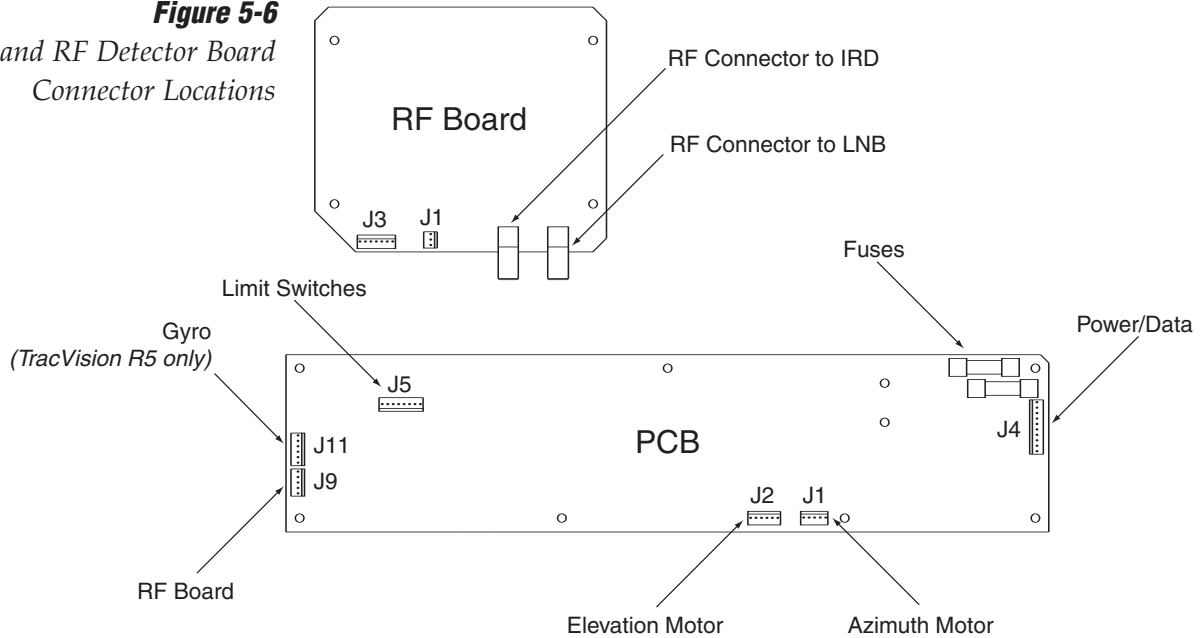

When replacing the PCB cover, be careful not to pinch any cables.

7. The PCB is mounted to the rotating plate with 9 pan head screws. Remove the screws and PCB.
8. Reverse this process to install the replacement PCB. Reinstall all cable connectors removed in Step 6.
9. (TracVision R5 only) Carry out all calibration procedures for the antenna gyro (Section 5.4.3).
10. Reinstall your preferred satellites as detailed in Section 2.5.1, "Installing Your Selected Satellites."

## 5.4.2 RF Detector/DVB Decoder

**Estimated Time to Repair: ½ hour**

The RF Detector PCB receives operating voltages from both the CPU board and the receiver (via the RF cable). Ensure that all power is turned off before proceeding.

1. Remove the 4 RF board cover screws and washers from the RF board cover.
2. Remove the RF board cover.
3. Remove the 2 RF connectors from the coaxial fittings on the RF board. Tag the cables to ensure that they are returned to the same connectors.
4. Remove the 2 Molex connectors from the RF board (J3 and J1) – Fig. 5-6.

5. Remove the 4 standoffs – *Fig. 5-1*. Remove the RF Detector PCB from the rotating plate.
6. Installation of the replacement RF Detector is the reverse of this procedure. Be sure that the RF cables are restored to their original positions. Be sure that the center conductor pin is centered in the connector before tightening the collar.

### 5.4.3 Antenna Gyro Assembly (*TracVision R5 only*)

#### Estimated Time to Repair: 1 hour

The antenna gyro is mounted on the rear of the antenna reflector bracket with four locking nuts and washers – *Fig. 5-3*. Following the removal and replacement of the antenna gyro assembly, it will be necessary to calibrate the gyro and restart the system. Directions for removal, replacement, and calibration follow:

1. Using needle-nose pliers, remove the E-ring from one end of the connecting rod – *Fig. 5-2*.
2. Remove the connecting rod by sliding it off the bracket.
3. Fully retract the elevation axis motor shaft – *Fig. 5-5*.
4. Remove 6 pan head screws from the PCB cover flanges.
5. Remove the PCB cover. To get the necessary clearance, rotate the linear actuator up 90° while lifting the PCB cover – *Fig. 5-5*.
6. Remove the screw and clamp holding the antenna gyro cable to the rotating plate. Be sure to save the cable clamp and screw – *Fig. 5-4*.
7. Remove the Molex connector from J11 on the PCB – *Fig. 5-6*.
8. Remove the 4 nuts and washers and take the gyro off of the bracket.
9. Remove the antenna gyro gasket.
10. Replacement is the reverse of this procedure.



*Following the removal and replacement of the antenna gyro assembly, it will be necessary to calibrate the gyro and restart the system as described in the next section.*

## Antenna Gyro Calibration

1. Connect a PC to the communications port as described in Section 4.4, "Computer Diagnostics."
2. Type **HALT** and press Enter while the system is performing the limit switch initialization routine. The system will complete the initialization function by finding the azimuth and elevation switch limits and then go to the home position.
3. Type **DEBUGON** and press Enter to enter Debug Mode.
4. Type **=CALGYRO** and press Enter. Verify that the Antenna Gyro Azimuth scale factor is between -0.00090 and -0.00110 and the Antenna Gyro Elevation scale factor is between 0.00090 and 0.00110.
5. Type **ZAP** and press Enter to restart the system.



The LNB receives power from the receiver via the RF Detector PCB. Be certain that the receiver is disconnected from its power source before removing or reconnecting the LNB.

**Figure 5-7**  
LNB Skew Angle Setting  
(European Systems Only)

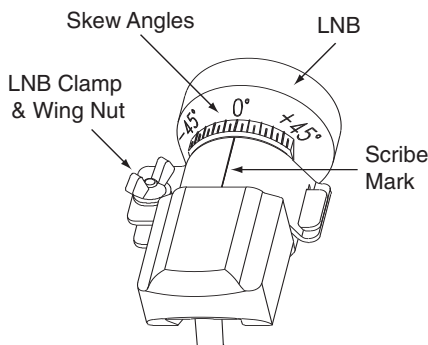

## 5.4.4 Antenna LNB Replacement

### Estimated Time to Repair: ½ hour

In the event that the LNB experiences problems, it may be necessary to replace it. To do so, use the following procedure:

1. (European systems only) Make a note of the current LNB skew angle, pictured in Figure 5-7.
2. Disconnect the RF cable connector(s) at the LNB.
3. Remove the wing nut and washer from the LNB clamp – Fig. 5-3.
4. Remove the top of the LNB clamp and remove the LNB.
5. Place the new LNB in the clamp and reattach the RF connector(s).
6. Replace the LNB clamp:
  - A. For North American LNBs, tighten the clamp fully. The replacement process is complete.
  - B. For European LNBs, do not fully tighten the clamp and proceed to Step 7.
7. (European systems only) Carefully turn the LNB so that the scribe mark is aligned with the skew angle noted in Step 1. Fully tighten the clamp to complete the replacement process.

## 5.5 Preparation for Shipment

If it is necessary to repack the antenna unit for shipment, the shipping restraints removed during installation must be replaced. Follow these steps to reinstall the restraints.

1. Remove the radome.
2. Rotate the antenna unit so that the LNB is facing away from the baseplate connectors.
3. Attach the three restraints to the baseplate using the  $\frac{1}{4}$ "-20 x  $\frac{3}{8}$ " hex screws and washers (provided in the kitpack) and nuts (removed from the restraints during installation) as pictured in Figure 5-8.

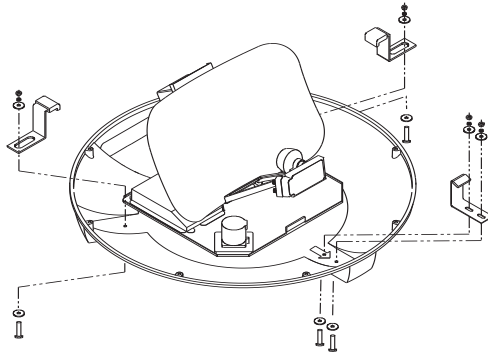

4. Place the antenna bracket on the forward shipping restraint.
5. Secure the forward restraint and bracket by wrapping two tie-wraps around the bend in the forward restraint and the antenna bracket (at the end of the LNB bracket).

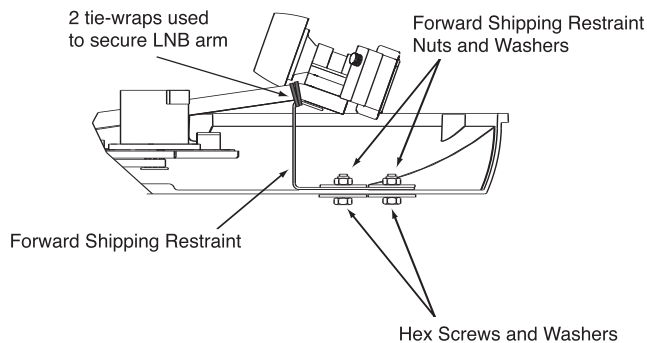

6. Replace the radome.
7. Place the entire antenna unit into its shipping box using the original packaging material. Secure the box to a pallet to ensure upright transport to KVH.



*When rotating the azimuth mechanism by hand, go slowly! Hitting the mechanical stops with excessive force will damage the azimuth limit switch.*

**Figure 5-8**

*Attaching the Shipping Restraints to the Antenna Baseplate*

**Figure 5-9**

*Securing the Forward Shipping Restraint*



*KVH is not liable for damage caused by improper shipping.*

# Appendix A

## System Specifications

### Physical Characteristics

|  |   |
|--|---|
| Power                                  | 11-16 volts DC @ 2.5 amps nominal,<br>3.5 amps peak               |
| Dimensions/Weight                      | 32" (81 cm) wide x 14.8" (38 cm) high,<br>33 lbs (15 kg)          |
| LNB                                    | European system: Single output<br>N. American system: Dual output |
| Tracking ( <i>TracVision R5 only</i> ) | Better than 30°/sec   |
| Maintenance Port                       | 9600 bps, 8,N,1,EIA, RS232  |

### Table A-1

*TracVision R5/R4 System  
Specifications*

### Pointing System

|                        |            |
|------------------------|------------|
| Elevation Range        | 15° to 75° |
| Azimuth Range          | 720°       |
| Position Repeatability | 0.1°       |

### Environmental

|                       |                                  |
|-----------------------|----------------------------------|
| Operating Temperature | -25°C to +55°C (-13°F to +131°F) |
| Storage Temperature   | -40°C to +85°C (-40°F to +185°F) |
| Humidity              | to 100 percent                   |

# Appendix B

## Switchplate Template

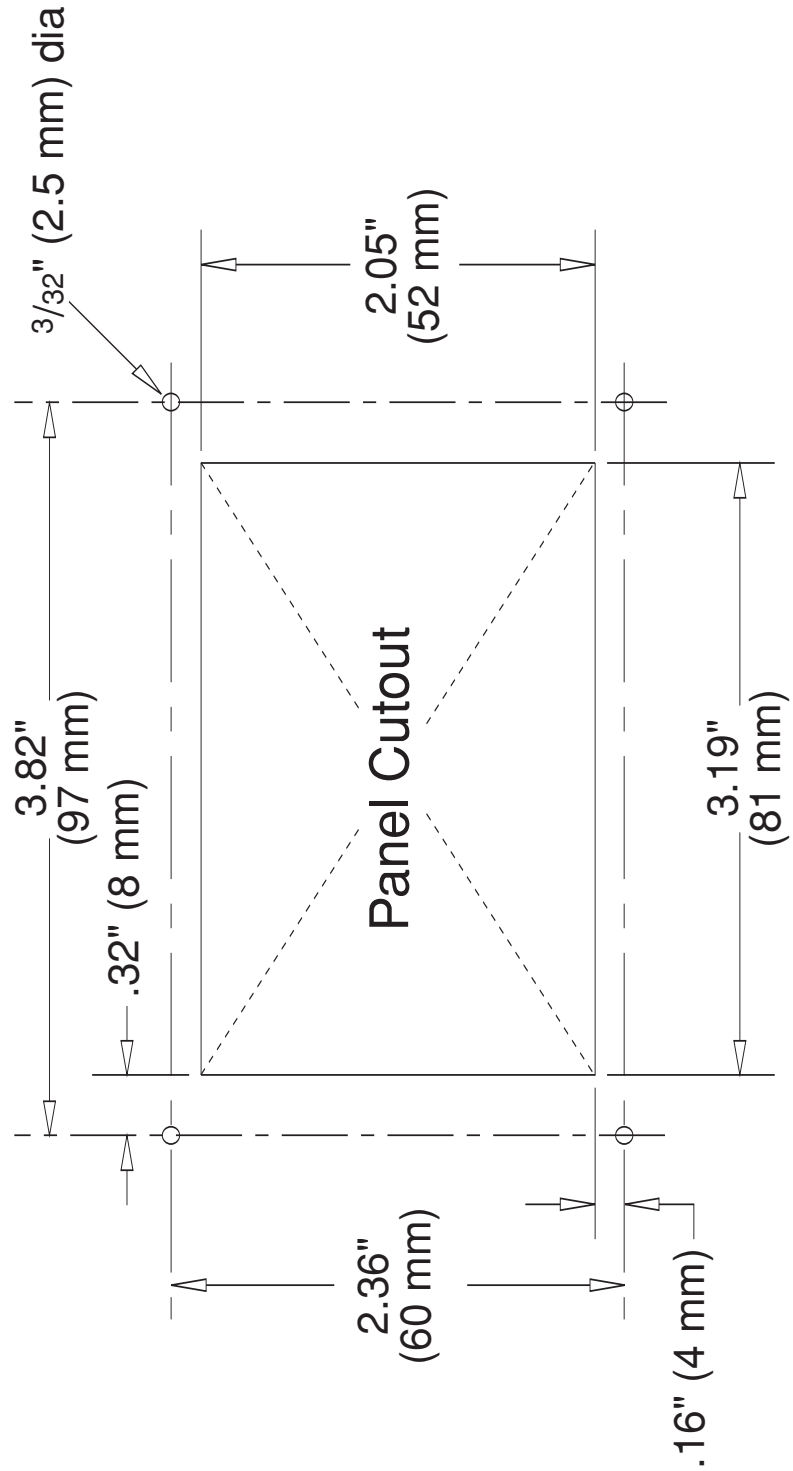





**KVH Industries, Inc.**

50 Enterprise Center Middletown, RI 02842 U.S.A.  
Phone: +1 401 847-3327 Fax: +1 401 849-0045  
E-mail: [info@kvh.com](mailto:info@kvh.com) Internet: [www.kvh.com](http://www.kvh.com)

**KVH Europe A/S**

Kokkedal Industripark 2B 2980 Kokkedal Denmark  
Phone: +45 45 160 180 Fax: +45 45 160 181  
E-mail: [info@kvh.dk](mailto:info@kvh.dk) Internet: [www.kvh.com](http://www.kvh.com)

KVH® and TracVision® are registered trademarks of KVH Industries, Inc.

Download from [Www.Somanuals.com](http://Www.Somanuals.com). All Manuals Search And Download.

TVR5/R40M\_Cover11.05

## Free Manuals Download Website

<http://myh66.com>

<http://usermanuals.us>

<http://www.somanuals.com>

<http://www.4manuals.cc>

<http://www.manual-lib.com>

<http://www.404manual.com>

<http://www.luxmanual.com>

<http://aubethermostatmanual.com>

Golf course search by state

<http://golfingnear.com>

Email search by domain

<http://emailbydomain.com>

Auto manuals search

<http://auto.somanuals.com>

TV manuals search

<http://tv.somanuals.com>