

TRACVISION[®]
BY KVH INDUSTRIES

TracVision M5

Switchplate Configuration



TracVision M5 Installation Guide

TracVision M5 Installation Guide

Switchplate Configuration

These instructions explain how to install the TracVision M5 satellite TV antenna system on a vessel. Complete instructions on how to use the system are provided in the *User's Guide*.

Installation Steps

1. Inspect Parts and Get Tools, 3
2. Plan the Antenna Installation, 4
3. Plan the Switchplate Installation, 5
4. Prepare the Antenna Site, 6
5. Remove the Restraints, 7
6. Wire the Antenna, 8
7. Mount the Antenna, 9
8. Wire the Switchplate, 10
9. Wire the Receiver(s), 11
10. Connect Power, 12
11. Mount the Switchplate, 13
12. Enter Your Latitude & Longitude, 14
13. Select Satellites, 16
14. Set the LNB Skew Angle (Linear only), 17
15. Educate the Customer, 18

Who Should Install the System?

To ensure a safe and effective installation, KVH recommends that a KVH-authorized marine technician install the TracVision antenna. KVH-authorized technicians have the tools and electronics expertise necessary to install the system. To find a technician near you, visit www.kvh.com/wheretogetservice.

Linear vs. Circular Systems

The installation process differs slightly depending on the type of LNB (low noise block) that is installed in the antenna (linear or circular). These differences are noted throughout this manual. Appendix B on page 22 notes the type of LNB required for each region and satellite.

Technical Support

If you need technical assistance, please contact KVH Technical Support:

North/South America, Australia:

Phone: +1 401 847-3327

E-mail: techs@kvh.com

Europe, Middle East, Asia:

Phone: +45 45 160 180

E-mail: support@kvh.dk

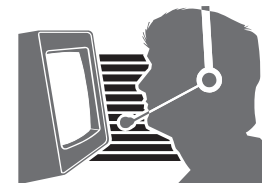

1 Inspect Parts and Get Tools

Before you begin, follow these steps to make sure you have everything you need to complete the installation.

- a. Unpack the box and ensure it contains everything shown on the *Kitpack Contents List*. Save the packaging for future use.

IMPORTANT!

Always lift the antenna by the baseplate and never by the radome or any portion of the internal antenna assembly (see Figure 1).

- b. Carefully examine all of the supplied parts to ensure nothing was damaged in shipment.
- c. Gather all of the tools and materials listed below. You will need these items to complete the installation.

- Flat-head and Phillips-head screwdrivers
- Electric drill and 3/8" (10 mm), 5/32" (4 mm), and 3/32" (2.25 mm) drill bits
- 3" (80 mm) hole saw
- Socket wrenches
- 7/16" open-end wrench
- Light hammer and center punch
- Adhesive tape and scribe or pencil
- Wire strippers and terminal lug crimper
- RG-6 or RG-11 RF coax cable(s) with Snap-N-Seal® F-connectors (see Figure 2); see Step 6a on page 8 to determine the number of cables required
- Connector installation tool (Augat IT1000 - KVH part #19-0242)
- Power cable (see Figure 3)
- Satellite TV receiver and TV
- Windows® laptop PC with Windows HyperTerminal or KVH Flash Update Wizard installed

Figure 1: TracVision M5 System Components

Antenna

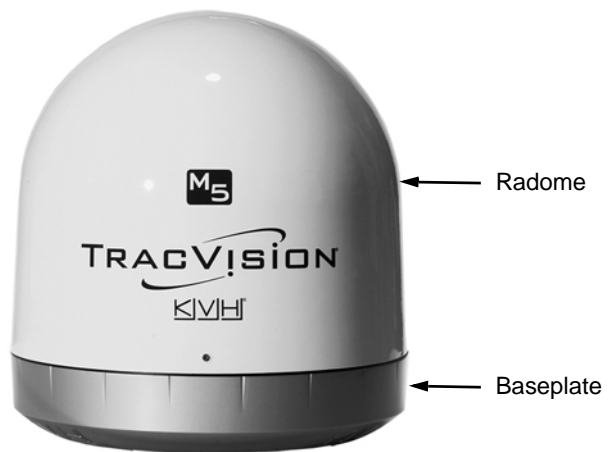

Switchplate



Figure 2: RF Cable Guidelines

| Cable Length | Use Cable Type |
|-----------------|----------------|
| <= 75 ft (23 m) | RG-6 |
| > 75 ft (23 m) | RG-11 |

Figure 3: Power Cable Guidelines

| Cable Length | Use Cable Gauge |
|--------------------|-----------------------------|
| < 40 ft (12 m) | 14AWG (2.5mm ²) |
| 40-70 ft (12-21 m) | 12AWG (4mm ²) |

2 Plan the Antenna Installation

Before you begin, consider the following antenna installation guidelines:

- Minimize blockage. The antenna requires a clear view of the sky to receive satellite TV (see Figure 4). The fewer obstructions, the better the system will perform.
- Make sure the mounting surface is wide enough to accommodate the antenna's base (see Figure 5). Also make sure it is flat, level, strong enough to support the antenna's weight (30 lbs, 13.6 kg), and rigid enough to withstand vibration.
- Select a location that is as close as possible to the intersection of the vessel's fore-and-aft centerline and midships.
- Do not mount the antenna at the same level as the radar because the radar's energy might overload the antenna. Ideally, you should mount the antenna 4 ft (1.2 m) above and 4 ft (1.2 m) away from the radar.

Figure 4: Blockage from Obstruction

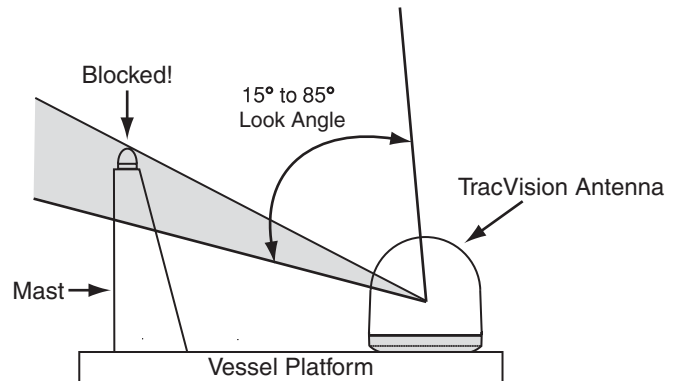
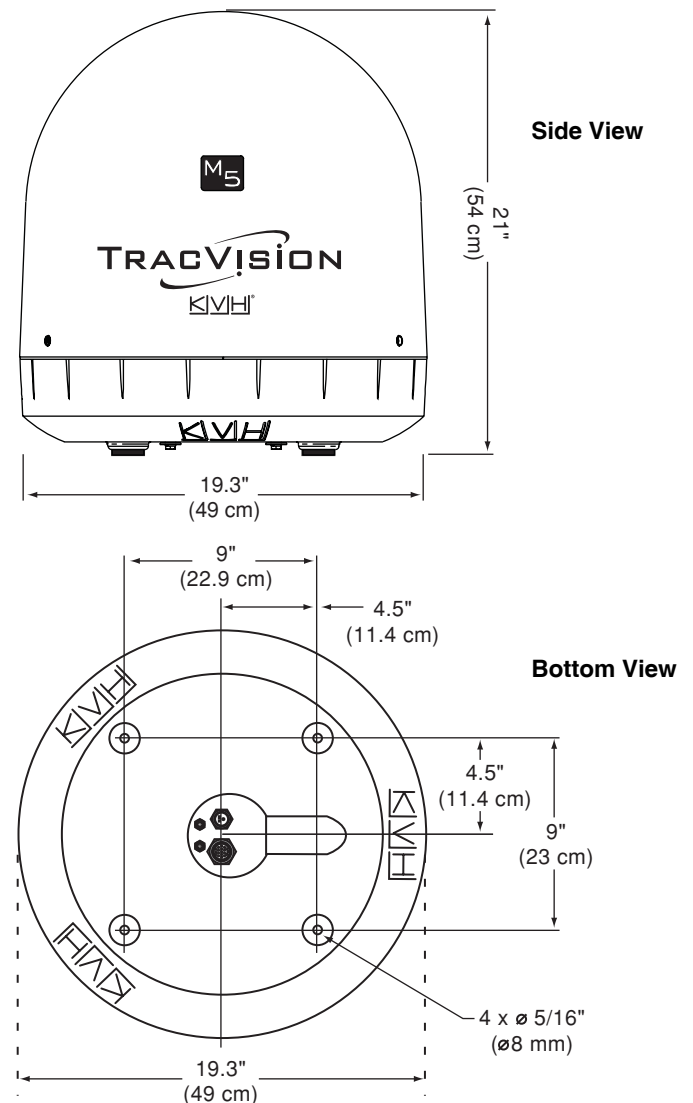

Figure 5: Antenna Dimensions



3 Plan the Switchplate Installation

Before you begin, consider the following switchplate installation guidelines:

- Select a switchplate mounting location in a dry, well-ventilated area belowdecks away from any heat sources or salt spray.
- Be sure to leave enough room at the switchplate's rear panel for connecting the cables (see Figure 6 for switchplate dimensions).
- Since the supplied data cable is 50 ft (15 m) long, the switchplate must be located within 50 ft (15 m) of the antenna.

Prepare the Switchplate Mounting Site

Once you have identified a suitable switchplate mounting site, follow these steps to prepare the site for installation.

- a. Using the switchplate mounting template provided at the end of this manual, mark and cut out a hole in the mounting surface to accommodate the switchplate (see Figure 7).
- b. Using the same template, mark the locations for the four switchplate mounting holes.
- c. Drill a $\frac{3}{32}$ " (2.25 mm) hole at the four mounting hole locations. Later, you will mount the switchplate using four #6 screws.

Figure 6: Switchplate Dimensions

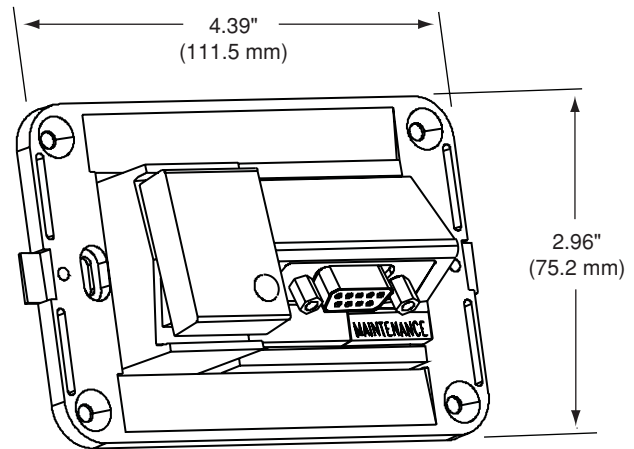
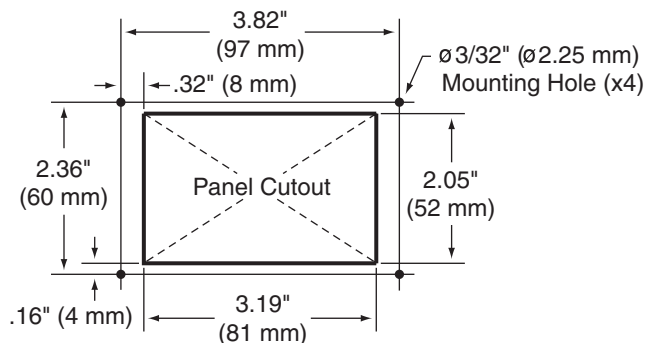

Figure 7: Switchplate Mounting Holes Layout



4 Prepare the Antenna Site

Once you have identified a suitable antenna mounting site, according to the guidelines provided in Step 2, follow these steps to drill the mounting holes and cable access hole to prepare the site for installation.

- a. Unfold the antenna mounting template (supplied in the Customer Welcome Kit) and place it onto the mounting surface. Make sure the "FWD" (forward) arrow points toward the bow and is parallel to the vessel's centerline (see Figure 8).

NOTE: You don't need to mount the antenna exactly on the vessel's centerline, but the antenna's forward arrow must be parallel to it.

- b. Use the template to mark the locations for the four mounting holes and cable access hole on the mounting surface.
- c. Drill a 3/8" (10 mm) hole at the four mounting hole locations you marked in Step 4b. Later, you will insert four 1/4"-20 bolts through these holes to secure the antenna to the mounting surface.
- d. Cut out the 3" (80 mm) cable access hole in the location you marked in Step 4b. Smooth the edges of the hole to protect the cables. Later, you will route the data, power, and RF cables through this hole and into the vessel.
- e. Clean and dry the antenna mounting surface.
- f. Peel off the paper backing from the supplied foam seal to expose the adhesive. Then press the foam seal down firmly onto the mounting surface, ensuring the narrow end points toward the bow and the hole in the foam seal aligns with the cable access hole in the mounting surface (see Figure 9).

Figure 8: Antenna Mounting Holes Layout

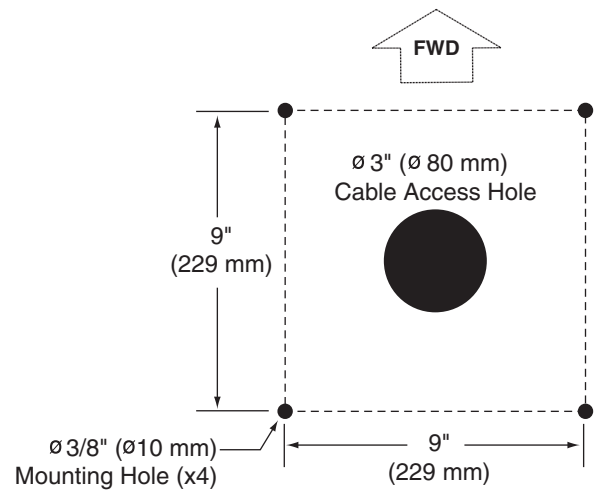
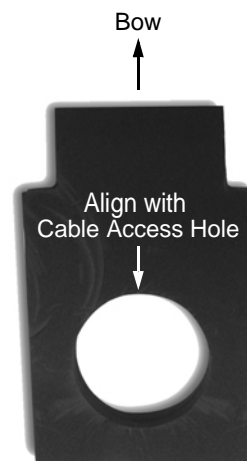

Figure 9: Foam Seal



5 Remove the Restraints

Inside the antenna, a foam block and two bolts prevent the antenna assembly from moving during shipment. Follow these steps to remove these shipping restraints.

- a. Remove the three #10-24 Phillips screws securing the radome to the baseplate. Carefully lift the radome straight up until clear of the antenna assembly and set it aside in a safe place.

TIP: If you keep the radome topside, secure it with a lanyard to prevent it from falling overboard.

- b. Remove the foam block that is wedged beneath the antenna's reflector (see Figure 10). Save this restraint for future use; the customer will need to reinstall it if he/she needs to relocate or reship the antenna.
- c. Using a 10 mm socket wrench, remove the two bolts, washers, and spacers securing the antenna assembly to the baseplate (see Figure 11 and Figure 12). Save these restraints for future use.

IMPORTANT!

Once you have removed the restraints, handle the antenna very carefully. With the restraints removed, the internal antenna assembly rotates freely and, if not handled properly, can damage the limit switch.

Figure 10: Foam Block Shipping Restraint

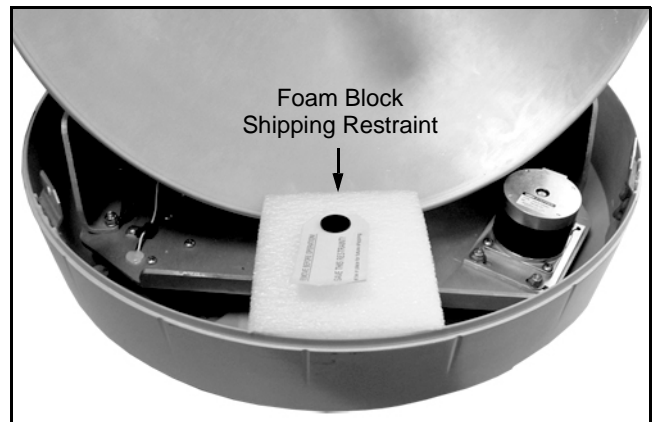

Figure 11: Shipping Restraint Hardware

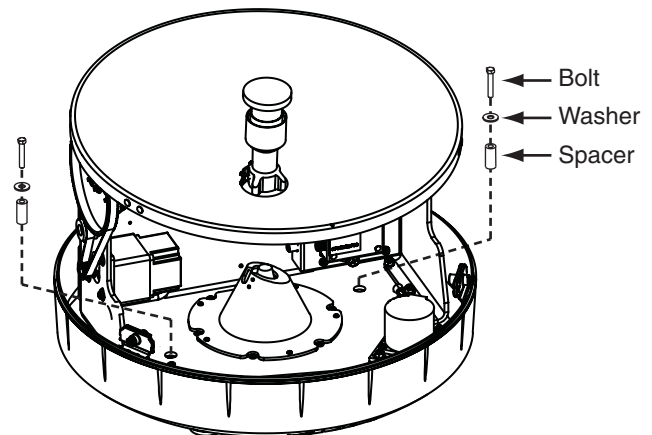
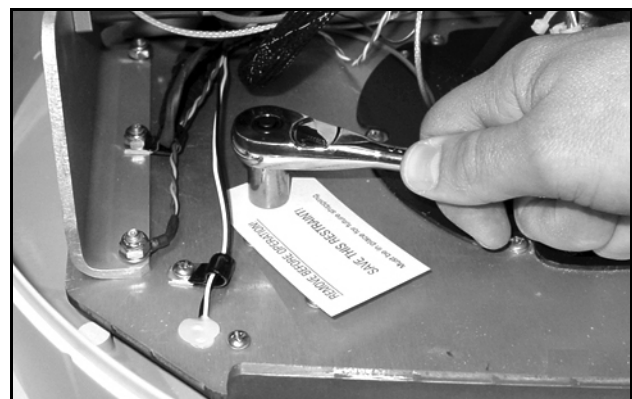

Figure 12: Removing the Shipping Restraint Bolts



6 Wire the Antenna

Follow these steps to connect the data, power, and RF cables to the antenna.

- a. First determine the number of RF coax cables required for your particular installation. If you wish to connect just one satellite TV receiver to the TracVision system, only one RF cable is required. If you wish to connect two or more receivers to the system, you need two RF cables. (See Figure 13 to determine the type of cable required.)
- b. Route the data, power, and RF cables belowdecks through the 3" (80 mm) cable access hole. Leave an adequate service loop, approximately 8" (20 cm) of slack, in the cables for easy serviceability. Later, you will connect the data and power cables to the switchplate and the RF cable(s) to the receiver(s).
- c. Connect the data cable to the "Data" jack on the bottom of the antenna (see Figure 14 and Figure 15). Hand-tighten until the connector locks in place; do not use excessive force.
- d. Connect the power cable to the "Power" jack on the bottom of the antenna. Hand-tighten until the connector locks in place; do not use excessive force.
- e. Connect an RF coax cable to the "RF1" jack on the bottom of the antenna. Hand-tighten, then tighten with a 7/16" wrench for 1/4 turn to ensure an electrical and weather-proof connection.
- f. If you wish to connect two or more receivers, connect a second RF coax cable to the "RF2" jack on the bottom of the antenna. Label both RF cables to match the antenna connectors so that you can easily identify the cables later.

Figure 13: RF Cable Guidelines

| Cable Length | Use Cable Type |
|-----------------|----------------|
| <= 75 ft (23 m) | RG-6 |
| > 75 ft (23 m) | RG-11 |

Figure 14: Connectors on Bottom of Antenna

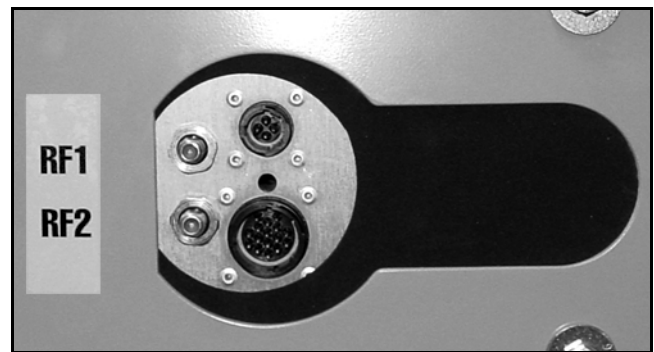
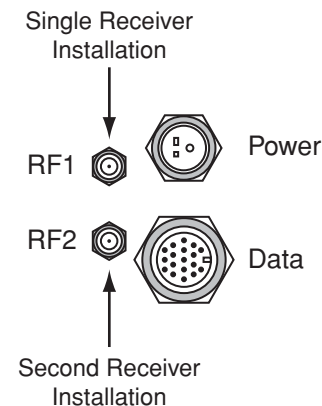

Figure 15: Antenna Cable Connections



7 Mount the Antenna

Follow these steps to mount the antenna to the mounting surface.

- Place the antenna baseplate over the holes drilled in the mounting surface. Ensure the "Forward" arrow inside the baseplate points toward the bow and is parallel to the vessel's centerline (see Figure 16).
- Make sure the four holes in the baseplate line up with the four holes in the mounting surface.

IMPORTANT!

You will need to rotate the antenna assembly by hand to see all four mounting holes. Rotate the antenna assembly slowly. If it hits a mechanical stop with excessive force, the limit switch might become damaged.

- At each of the four baseplate mounting holes, place a 1/4" flat washer on a 1/4"-20 bolt and insert the bolt into the hole from above (see Figure 17).
- Secure each mounting bolt to the mounting surface using a 1/4" flat washer and a 1/4"-20 lock nut from below. Tighten all four bolts until the four rubber feet are bottomed against the mounting surface and the foam seal is fully compressed.

TIP: If you are installing a linear system, you may wish to keep the radome off for now. Later, you will need to adjust the skew angle of the antenna's LNB.

- Reinstall the radome onto the antenna. Secure in place with the three #10-24 screws you removed in Step 5a (see Figure 18).
- Install a protective plastic screw cap (supplied in the kitpack) over each radome screw.

Figure 16: "Forward" Arrow in Antenna Baseplate

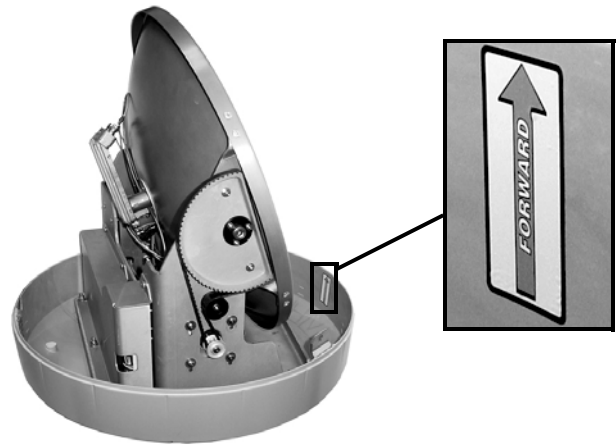

Figure 17: Mounting the Antenna (Side View)

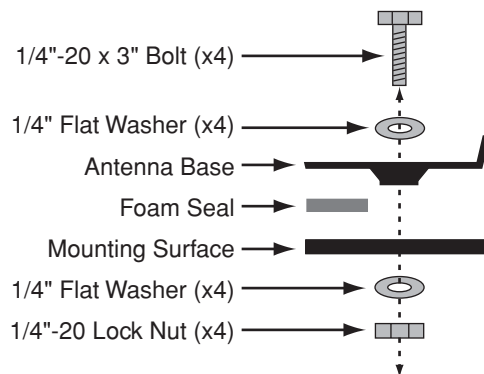
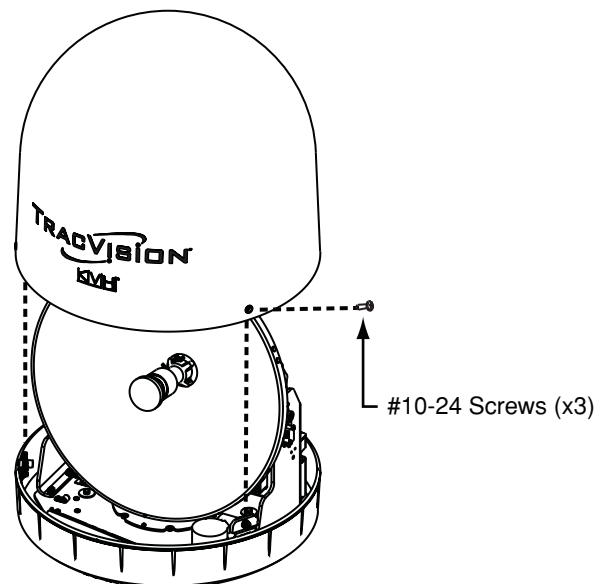

Figure 18: Installing the Radome



8 Wire the Switchplate

Follow these steps to connect the switchplate to the antenna.

NOTE: System wiring diagrams are provided in Appendix D on page 26.

- a. First dress the data and power cables from the antenna. Strip back the insulation of each wire approximately 1/4" (6 mm) and gently twist each wire to ensure a good electrical connection.
- b. Connect the data cable from the antenna to the terminal board on the back of the switchplate (see Figure 19). Be sure to match the wire colors with the terminal board label. Tighten the terminal screws to secure all wires in place.

IMPORTANT!

The diagram refers to wires by **body color/ stripe color**. For example, "Blue/White" means the blue wire with the white stripe.

IMPORTANT!

Do not connect the data cable's drain wire (shield) to anything. You can simply snip it from the cable.

- c. Connect the power cable from the antenna to the switchplate's power output terminals (see Figure 20).

Figure 19: Switchplate Wiring - Antenna Data Cable

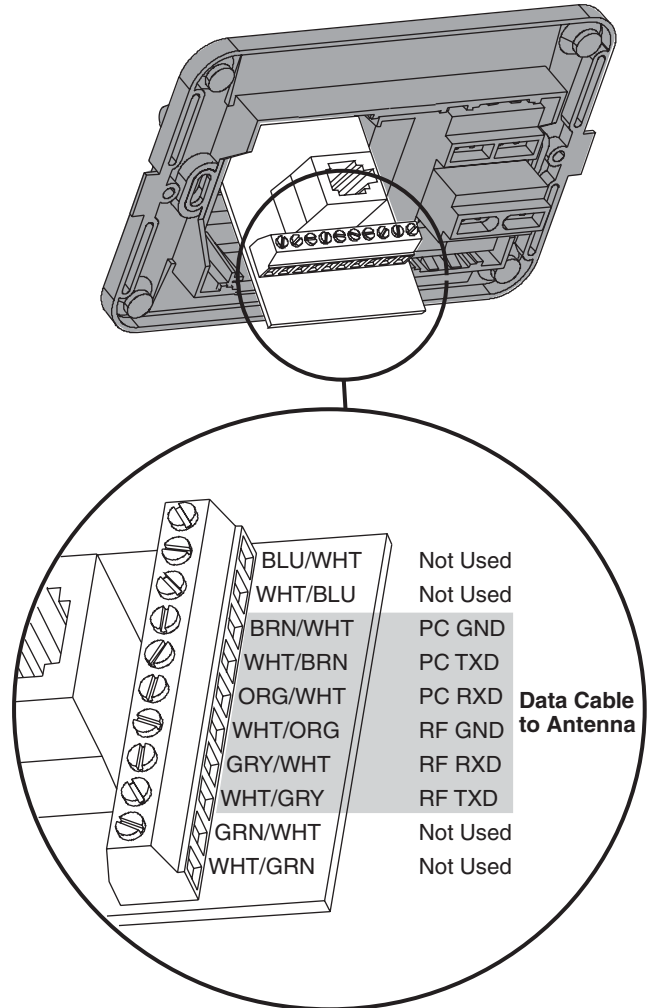
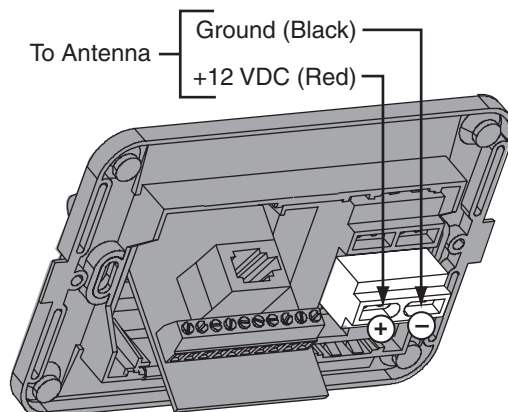

Figure 20: Switchplate Wiring - Antenna Power Cable



9 Wire the Receiver(s)

In Step 6, you routed the RF coax cables from the antenna, through the cable access hole, and into the vessel. Follow these steps to connect the RF coax cable(s) to the customer's satellite TV receiver(s).

IMPORTANT!

If you wish to connect **three or more** receivers to the antenna, see Appendix A on page 21.

- a. If you are connecting two receivers to the TracVision system, decide which receiver will be the primary receiver. The primary receiver controls satellite selection.

NOTE: The secondary receiver will only be able to select a channel carried on the satellite that is currently selected on the primary receiver.

- b. Connect the RF1 cable from the antenna to the "Satellite In" jack on the primary receiver (see Figure 21).
- c. If you are connecting two receivers, connect the RF2 cable from the antenna to the "Satellite In" jack on the secondary receiver.

IMPORTANT!

Be sure all receivers are grounded. If the receiver has a 2-prong power plug, run a ground wire from the receiver's chassis to a suitable ground point. If a potential exists between AC and DC grounds, connect the wire to the switchplate's DC return instead.

- d. Connect the receiver(s) to the customer's television(s). Follow the instructions in the receiver's manual.

Figure 21: Wiring the Receivers to the Antenna

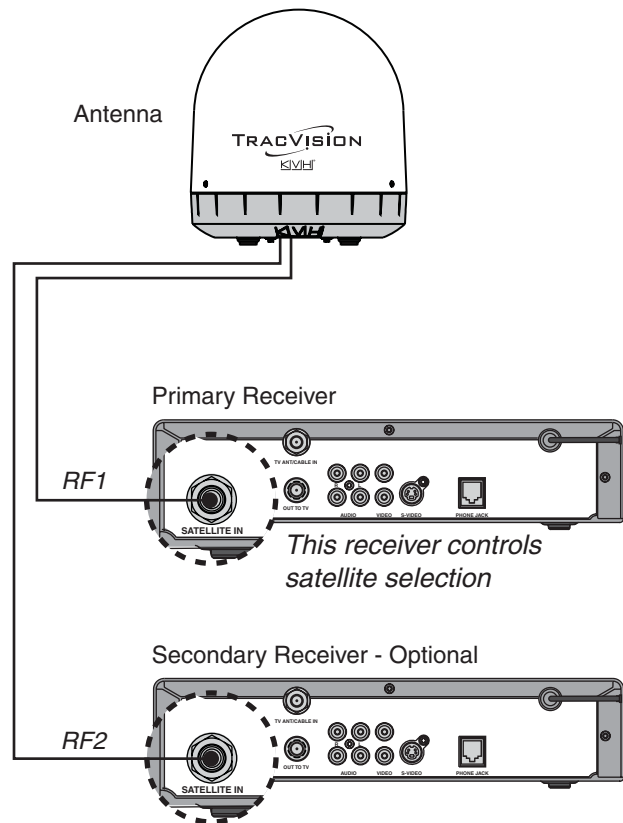

10 Connect Power

Follow these steps to connect power. The switchplate supplies power to the antenna.

- a. Before you begin, disconnect vessel power.

| | |
|--|----------------|
|  | CAUTION |
| For your own safety, disconnect vessel power and make sure the circuit is dead before you connect any power wires. | |

- b. Connect a power cable to 12 VDC vessel power (for cable specifications, see Figure 3 on page 3).

IMPORTANT!

Power supplied to the antenna must not fall below 11 VDC or exceed 16 VDC.

- c. Connect your vessel power wires to the power (+) and ground (-) input terminals on the switchplate (see Figure 22).

Figure 22: Switchplate Wiring - Vessel Power Cable

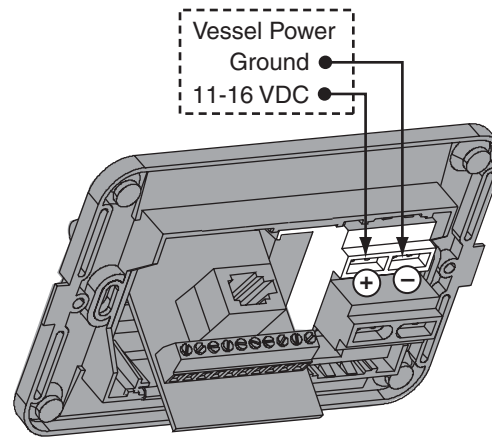

11 Mount the Switchplate

In Step 3 on page 5, you identified a suitable location for the switchplate and cut out the mounting hole in the mounting surface. Now follow these steps to mount the switchplate.

- a. Fit the switchplate assembly into the mounting hole until it is flush with the mounting surface.
- b. Drill four $5/32$ " (4 mm) holes in the countersunk settings in the switchplate's support frame (see Figure 23).
- c. Secure the support frame and switchplate assembly to the mounting surface using four #6 screws.
- d. Snap the front cover onto the switchplate to conceal the mounting screws and support frame.

Figure 23: Mounting the Switchplate

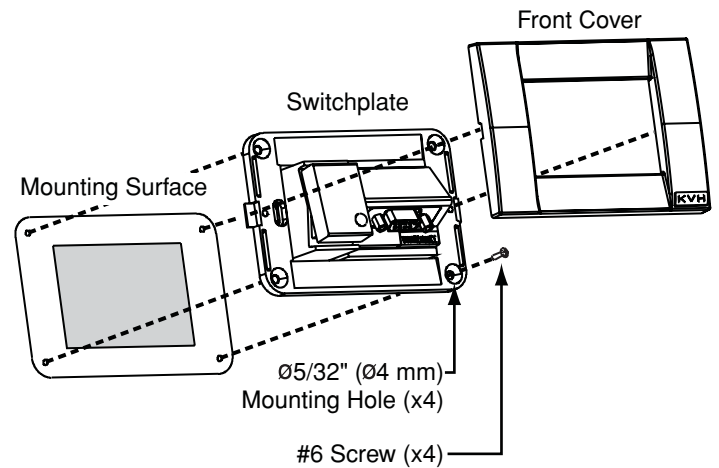

12 Enter Your Latitude & Longitude

Follow these steps to enter your vessel's latitude and longitude into the antenna.

NOTE: The antenna will use your position information to speed up satellite acquisition. If the antenna knows where you are, it knows where it should start looking for the satellite (see Figure 24). In addition, for a linear system, the antenna will use your position information to calculate the correct LNB skew angle.

Connect a Laptop to the Antenna

To enter data into the antenna, you first need to connect a Windows® laptop computer to the TracVision system and start Windows HyperTerminal.

TIP: If you are a KVH-authorized technician, you can use the KVH Flash Update Wizard instead of HyperTerminal. Enter commands in the wizard's "Antenna Comms" window.

- a. Using a straight PC serial data cable, connect your laptop to the DB9 Maintenance port on the front of the switchplate (see Figure 25).

NOTE: If your computer does not have a DB9 serial COM port, you can use the USB-to-RS232 adapter manufactured by IOGear (IOGear part number GUC232A) or Belkin (Belkin part number F5U109).

- b. Open Windows HyperTerminal and establish the following settings for your COM port (see Figure 26):

- Bits per second: 9600
- Data bits: 8
- Parity: None
- Stop bits: 1
- Flow control: None

TIP: To view characters on the screen as you type, set up HyperTerminal to echo typed characters. Select "Properties" from the File menu; select "ASCII Setup" at the Settings tab; then select "Echo typed characters locally" at the ASCII Setup window.

Figure 24: Direction to Satellite Depends on Your Location

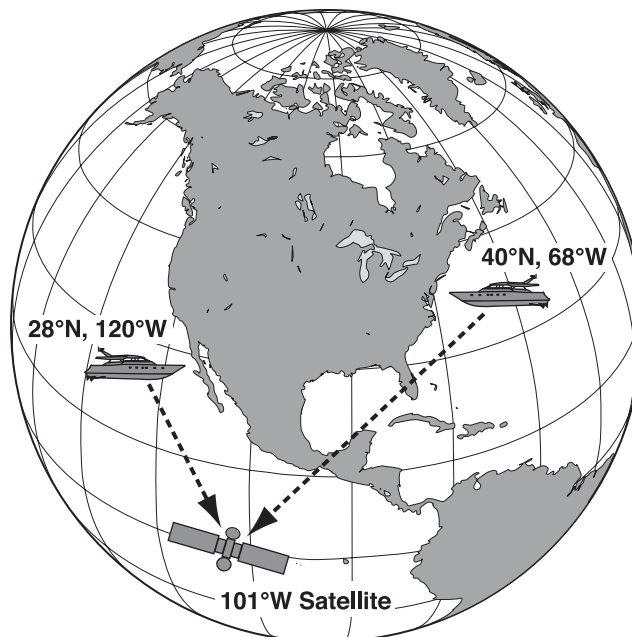

Figure 25: Switchplate Front Panel

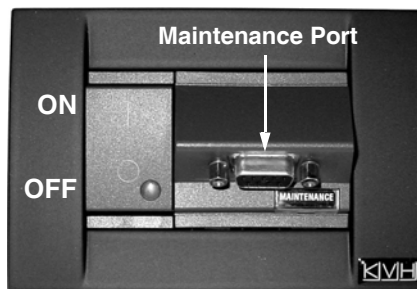
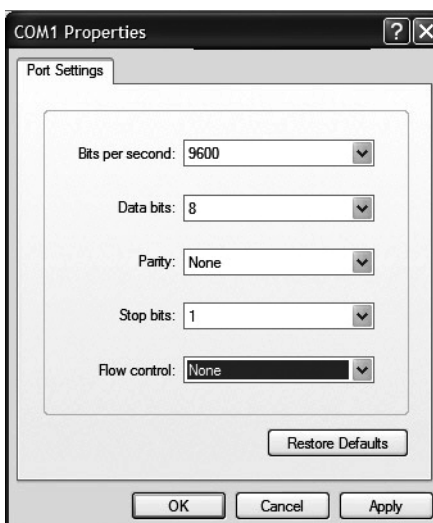

Figure 26: HyperTerminal Settings



12 Continued...

- c. Ensure the antenna has a clear, unobstructed view of the sky.
- d. Apply power to the satellite TV receiver(s) and the switchplate (see Figure 25 on page 14). Wait two minutes for system startup.
- e. Data should now be scrolling in your HyperTerminal window (see Figure 27). If no data appears, check your connections and make sure you're using the right COM port.

Enter Your Latitude and Longitude

To enter your position information into the antenna, enter the following commands via Windows HyperTerminal or KVH Flash Update Wizard:

- a. Type **HALT** then press Enter.
- b. Type **DEBUGON** then press Enter.
- c. Type the following command then press Enter. Italics indicate a variable.

GPS,XX,A,YYY,B

XX = Latitude (0 - 90)

A = **S** (South) or **N** (North)

YYY = Longitude (0-180)

B = **E** (East) or **W** (West)

NOTE: Do not enter decimals. Simply round your latitude and longitude to the nearest whole numbers.

Figure 27: Antenna Data Scrolling in Window

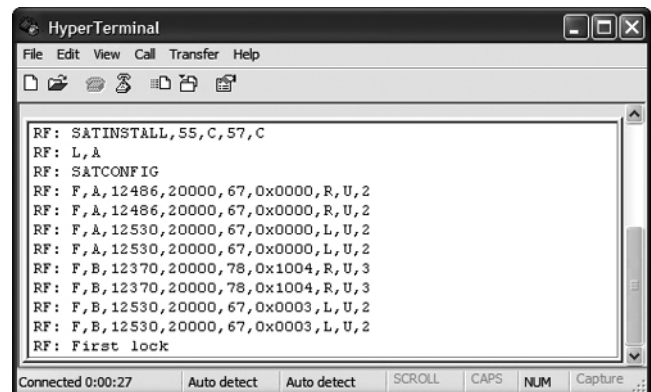

EXAMPLE

Entering a vessel position of 57°N, 22°E:

HALT

DEBUGON

GPS,57,N,22,E

13 Select Satellites

Follow these steps to set up the system for the desired pair of satellites.

IMPORTANT!

The antenna is programmed at the factory for the following default satellite pair:

Circular: DSS_101 & DSS_119 (DIRECTV)

Linear: ASTRA & HOTBIRD

If these are the customer's desired satellites, you may skip this step.

Enter the following commands via Windows HyperTerminal or KVH Flash Update Wizard:

- a. Type **HALT** then press Enter.
- b. Type **DEBUGON** then press Enter.
- c. Type the following command then press Enter. Italics indicate a variable.

SATINSTALL,*SatelliteA*,*SatelliteB*

SatelliteA = Name of 1st desired satellite

SatelliteB = Name of 2nd desired satellite

See Appendix B on page 22 for a list of all available satellites. Be sure to enter the satellite names as they appear in the library.

NOTE: If you don't find the satellite you want, you can set up a user-defined satellite (USER 1 or USER 2). See Appendix C on page 23.

- d. Type **@L,A** then press Enter.
- e. Type **ZAP** then press Enter. The antenna restarts. Wait two minutes for system startup.
- f. **(Linear only)** Set up the receiver(s) for the same satellites, and in the same order, that you set them up in the antenna:

| Antenna | Receiver | DiSEqC |
|---------|--------------------|----------|
| Sat. A | Alternative 1 or A | DiSEqC 1 |
| Sat. B | Alternative 2 or B | DiSEqC 2 |

Figure 28: Technician Programming the Antenna



EXAMPLE

Programming Astra2S and Thor satellites:

HALT

DEBUGON

SATINSTALL,ASTRA2S,THOR

@L,A

ZAP

14 Set the LNB Skew Angle (Linear only)

Follow these steps to set the antenna's linear LNB to the correct skew angle for your selected satellite and vessel position.

- a. Using HyperTerminal or KVH Flash Update Wizard, type **SKEWANGLE** then press Enter. Note the reported skew angle.

TIP: If two satellites are installed, you might wish to set an **average skew** instead. To find the average skew, select the second satellite then repeat Step 14a to get the second satellite's skew angle. Add the two skew angle numbers and divide by two to get the average.

- b. Turn off and unplug the receiver(s) and disconnect antenna power at the switchplate.



CAUTION

Disconnect power from the antenna and the receivers before you adjust the LNB. The antenna's moving parts can cause injury.

- c. Remove the antenna's radome, if you installed it earlier in Step 7e.
- d. Locate the LNB on the back of the antenna's reflector (see Figure 29).
- e. Loosen the two wing screws on the base of the antenna's feed tube, located in the center of the reflector (see Figure 30).
- f. Adjust the LNB clockwise or counter-clockwise until the skew arrow on the LNB points to the skew angle that you noted in Step 14a (see Figure 31). If the skew angle is greater than $+15^\circ$, subtract 180 to get the equivalent negative skew angle and set the LNB to that angle instead.

IMPORTANT!

Be sure to keep the LNB fully inserted into the choke feed to ensure optimum performance.

- g. Tighten the wing screws to secure the LNB.
- h. Reinstall the radome (as explained in Steps 7e-f on page 9).

Figure 29: LNB Location on Back of Antenna's Reflector

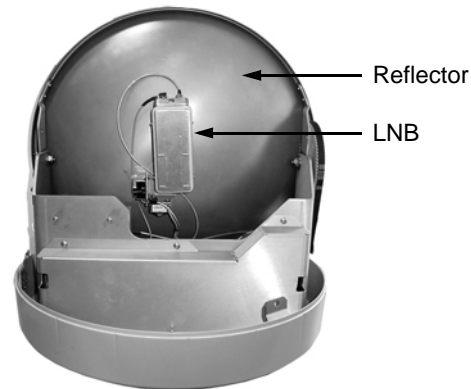

Figure 30: Wing Screws Securing the LNB to the Reflector

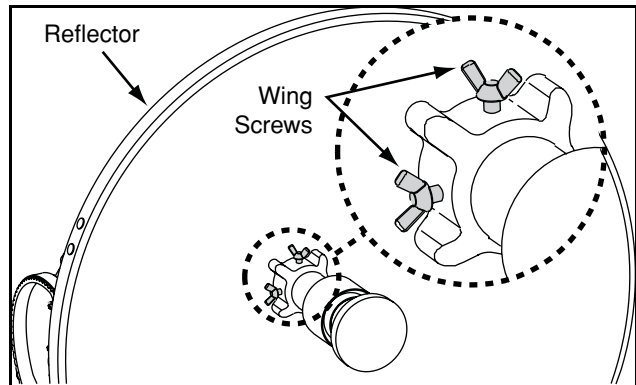
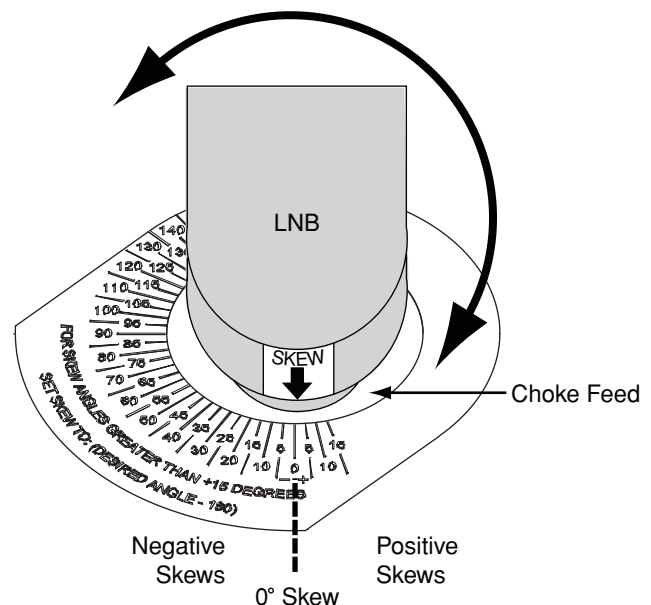

Figure 31: LNB Skew Angle Adjustment



15 Educate the Customer

The installation process is complete!

Before you depart the vessel, test the system to verify the antenna works properly. Then give the Customer Welcome Kit to the customer and explain how to use the system. Also be sure the customer understands the following:

- Keep the radome installed on the antenna at all times. The radome protects the antenna's moving parts from wind, rain, and debris.



WARNING

It is dangerous to watch TV while piloting a vessel. The TracVision system is intended as a passenger entertainment product only.

- The antenna must have a clear view of the sky to receive satellite TV. Common causes of blockage include trees, buildings, bridges, and onboard equipment (see Figure 32).
- Heavy rain or snow may temporarily interrupt reception.
- Clean the antenna regularly. Dirt buildup on the radome can affect reception.
- The vessel must be located within the selected satellite's coverage area to receive its satellite TV signals. To view satellite coverage maps, visit www.kvh.com/footprint.
- Please register the system with KVH. The registration process is quick, easy, online, and ensures the best possible service from KVH. Visit www.kvh.com/register or refer to the Product Registration Form for details.
- You need to activate the receiver for the desired satellite TV service before the receiver can decode satellite signals. KVH can help you activate a DIRECTV receiver; just call KVH's Activation Department at 1-888-584-4163 (Mon.-Fri., 8:30 am - 5 pm ET)
- Refer to the *User's Guide* for complete operation instructions and troubleshooting information.

Figure 32: Example of Satellite Blockage

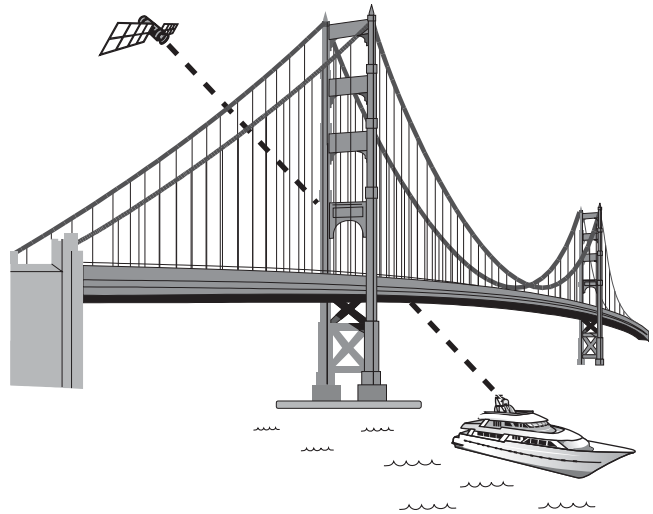

Appendices

This section provides supplemental instructions for special or advanced configurations. It also provides system wiring diagrams and a mounting template for the belowdecks equipment.

Contents

A. Wiring 3+ Receivers (Circular only), 21

B. Satellite Library, 22

C. User-Defined Satellites, 23

D. Wiring Diagrams, 26

Switchplate Mounting Template, 29

A Wiring 3+ Receivers (Circular only)

Appendix

IMPORTANT!

Only antennas equipped with a circular dual LNB can support more than two receivers. Antennas equipped with a linear LNB support only two receivers.

To connect three or more receivers, follow these steps to install an active (powered) multiswitch between the antenna and the receivers.

NOTE: You can purchase an active multiswitch, Channel Master model 6314IFD, from KVH (order part #19-0123).

1. Connect the RF1 cable from the antenna to the "RHCP +13V" jack on the multiswitch (see Figure 33).
2. Connect the RF2 cable from the antenna to the "LHCP +18V" jack on the multiswitch.
3. Connect the receivers to the individual outputs of the multiswitch.
4. Terminate any unused multiswitch outputs with 75 ohm DC blocks (Channel Master #7184, Radio Shack #15-1259, or equivalent).

IMPORTANT!

Be sure the multiswitch is properly grounded. With the multiswitch grounded, you do not need to ground the individual receivers.

IMPORTANT!

(DIRECTV only) Multiswitches block a receiver's 22 KHz tone that the antenna needs to switch satellites automatically. Therefore, the customer will need to manually switch satellites using the optional TV/SAT Switch (KVH part #01-0245).



Figure 33: Multiswitch Wiring - Antenna with Circular Dual LNB

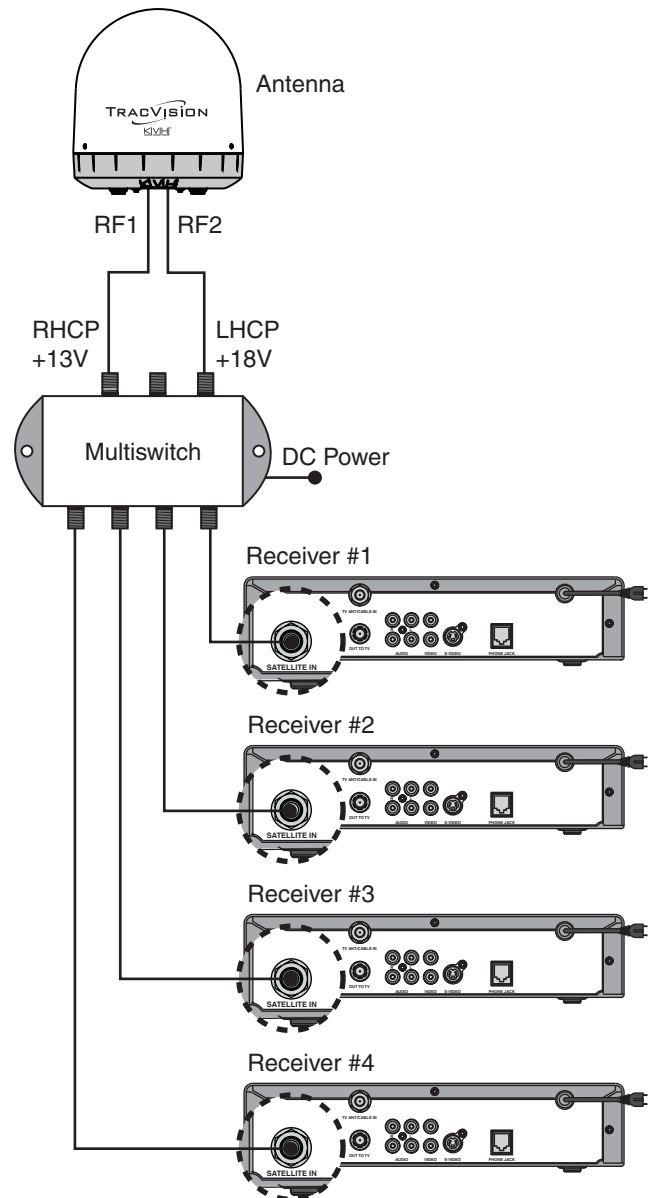

B Satellite Library

Appendix

The TracVision antenna can track a variety of DVB-compatible and DSS (DIRECTV) satellites. Most popular satellites are programmed in the antenna's library (see the tables below).

North America

Standard Circular Dual LNB Required

| Satellite, Longitude | Name in Library |
|----------------------|-----------------|
| DIRECTV, 72°W | DSS_72 |
| DIRECTV, 101°W | DSS_101 |
| DIRECTV, 110°W | DSS_110 |
| DIRECTV, 119°W | DSS_119 |
| EchoStar, 61°W | ECHO_61 |
| EchoStar, 110°W | ECHO_110 |
| EchoStar, 119°W | ECHO_119 |
| EchoStar, 148°W | ECHO_148 |
| ExpressVu, 82°W | EXPRESSVU |
| ExpressVu, 91°W | EXPRESSTV |

Asia

Standard Circular Dual LNB Required

| Satellite | Name in Library |
|---------------------|-----------------|
| Asiasat 4, 122.2°E | ASIASAT |
| Sinosat 1*, 110.5°E | SINOSAT |

Latin America

Galaxy Circular Dual LNB Required

| Satellite | Name in Library |
|-----------------|-----------------|
| Galaxy 3C, 95°W | GALAXY3CN |

Europe

Linear Dual LNB Required

| Satellite | Name in Library |
|--------------------|-----------------|
| Astra 1, 19.2°E | ASTRA1 |
| Astra 2N, 28.2°E | ASTRA2N |
| Astra 2S, 28.2°E | ASTRA2S |
| Hispasat, 30.0°W | HISPASAT |
| Hotbird, 13.0°E | HOTBIRD |
| Hotbird WB, 13.0°E | HOTBIRDWB |
| Sirius, 5.0°E | SIRIUS |
| Thor, 0.8°W | THOR |
| Arabsat, 26°E | ARABSAT |
| Nilesat, 7°W | NILESAT |
| Turksat 1C, 42°E | TURKSAT1C |
| Eutelsat W3A, 7°E | EUTEL_W3A |

Mexico

Linear Dual LNB Required

| Satellite | Name in Library |
|-------------|-----------------|
| PAS 9, 58°W | PAS_9 |

Australia & New Zealand

Linear Dual LNB Required

| Satellite | Name in Library |
|------------------|-----------------|
| Optus B1*, 160°E | OPTUS_B1 |
| Optus C1, 156°E | OPTUS_C1 |

* Special LNB required. Call KVH at 1-401-847-3327.



User-Defined Satellites

The satellite library in the TracVision antenna includes two slots for user-defined satellites (USER 1 and USER 2). You can program one or both of these library slots for any satellite you wish that is not already set up in the library.

To configure a user-defined satellite, you will need to program into the antenna the following information about the satellite (see Figure 34):

- Satellite name
- Satellite longitudinal position
- Transponder information for all combinations of polarization and band:
 - vertical high
 - vertical low
 - horizontal high
 - horizontal low

OR

- right
- left
- Frequency
- Symbol rate
- FEC code rate
- Network ID
- Decoder type

NOTE: You can find this satellite information on the web at www.lyngsat.com or www.satcodx.com (neither website is affiliated with KVH).

Figure 34: Identifying a Linear Satellite

| | |
|-------------------------|------------------------|
| Name | |
| Longitude | |
| Decoder type | |
| Vertical High: | Vertical Low: |
| Frequency | Frequency |
| Symbol rate | Symbol rate |
| FEC code | FEC code |
| Network ID | Network ID |
| Horizontal High: | Horizontal Low: |
| Frequency | Frequency |
| Symbol rate | Symbol rate |
| FEC code | FEC code |
| Network ID | Network ID |

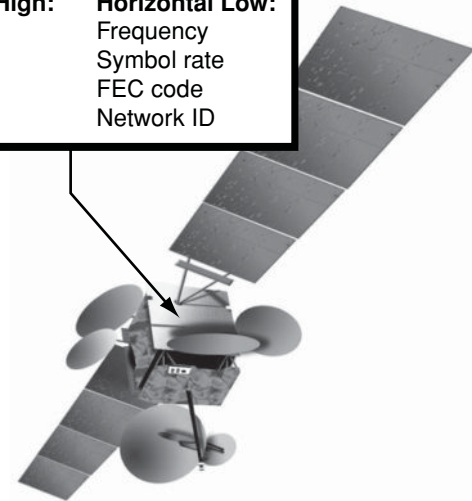

C Continued...

Enter the following commands via Windows HyperTerminal or KVH Flash Update Wizard.

1. Type **HALT** then press Enter.
2. Type **DEBUGON** then press Enter.
3. Type the following **SATCONFIG** command then press Enter. Italics indicate a variable field (see Figure 35 for definitions).

SATCONFIG,USERA,B,C,D,E →

4. Type **@DEBUGON** then press Enter.
5. Type the following **@SATCONFIG** command then press Enter. Italics indicate a variable field (see Figure 36 for definitions).

@SATCONFIG,F,G,H,I,J,K,L,M,N →

6. Repeat Step C5 for each polarization/band:
 - Vertical High • Horizontal High
 - Vertical Low • Horizontal Low

OR

 - Right • Left

If your selected satellite does not have data for one or more of these transponder categories, you can enter the following defaults instead:

| Transponder Data | Default Value |
|------------------|----------------------------------|
| Frequency | 00000 |
| Symbol rate | 27500 |
| FEC code rate | Same value as other transponders |
| Network ID | 0x0000 |

7. Type **ZAP** then press Enter. The antenna restarts. Wait two minutes for system startup.
8. Follow the instructions in Step 13 on page 16 to select your new USER 1 or USER 2 satellite.

Figure 35: SATCONFIG Command Fields

| Field | Description |
|-------|--|
| A | User-defined satellite in library (1=User 1; 2=User 2) |
| B | Longitude (0-180) |
| C | E (East) or W (West) |
| D | Decoding type (2=DSS, 3=DVB) |
| E | Polarization (C=circular, L=linear) |

Figure 36: @SATCONFIG Command Fields

| Field | Description |
|-------|--|
| F | User-defined satellite in library (A=User 1; B=User 2) |
| G | Satellite table # (98=User 1; 99=User 2) |
| H | Frequency, MHz (00000 or 10700-12750) |
| I | Symbol rate, kilosymbols per second (01000-45000) |
| J | FEC code rate (12, 23, 34, 56, 67, or 78) |
| K | Network ID, hexadecimal (0x####) |
| L | Polarization (V=vertical; H=horizontal; R=right; L=left) |
| M | LNB down conversion frequency (L=low [9750 MHz]; H=high [10600 MHz]; G=Galaxy [10500 MHz]; S=Sinosat [11300 MHz]; U=USA [11250 MHz]) |
| N | Decoding type (2=DSS; 3=DVB) |

Continued...

Example - Linear Satellite

The following is an example of programming a linear user-defined satellite (USER 1).

Satellite Name: YOURSAT 123 at 7°W

| Transponder Data | Value |
|------------------------|---------------------|
| <i>Horizontal High</i> | |
| Frequency | 11.966 GHz |
| Symbol rate | 27500 |
| FEC code rate | 3/4 |
| Network ID | 2048 (dec) = 0x0800 |
| <i>Vertical High</i> | |
| Frequency | 11.823 GHz |
| Symbol rate | 27500 |
| FEC code rate | 3/4 |
| Network ID | 2048 (dec) = 0x0800 |
| <i>Vertical Low</i> | |
| No data listed | |
| <i>Horizontal Low</i> | |
| No data listed | |

Commands you would enter into the antenna via HyperTerminal or KVH Flash Update Wizard:

```

HALT
DEBUGON
SATCONFIG,USER1,7,W,3,L
@DEBUGON
@SATCONFIG,A,98,11966,27500,34,0x0800,H,H,3
@SATCONFIG,A,98,11823,27500,34,0x0800,V,H,3
@SATCONFIG,A,98,00000,27500,34,0x0000,V,L,3
@SATCONFIG,A,98,00000,27500,34,0x0000,H,L,3
ZAP

```

Example - Circular Satellite

The following is an example of programming a circular user-defined satellite (USER 1).

Satellite Name: YOURSAT 456 at 122°W

| Transponder Data | Value |
|------------------|---------------------|
| <i>Right</i> | |
| Frequency | 12.225 GHz |
| Symbol rate | 20000 |
| FEC code rate | 5/6 |
| Network ID | 4100 (dec) = 0x1004 |
| <i>Left</i> | |
| Frequency | 12.456 GHz |
| Symbol rate | 20000 |
| FEC code rate | 5/6 |
| Network ID | 4100 (dec) = 0x1004 |

Commands you would enter into the antenna via HyperTerminal or KVH Flash Update Wizard:

```

HALT
DEBUGON
SATCONFIG,USER1,122,W,3,C
@DEBUGON
@SATCONFIG,A,98,12225,20000,56,0x1004,R,U,3
@SATCONFIG,A,98,12456,20000,56,0x1004,L,U,3
ZAP

```

D Wiring Diagrams

Appendix

This appendix provides system wiring diagrams for the following receiver configurations:

- One or two receivers
- Three or more receivers (circular only)

IMPORTANT!

The wiring diagrams on the following pages are intended as a quick reference only. Be sure to follow the complete wiring instructions provided earlier in this manual.

D Continued...

Wiring One or Two Receivers

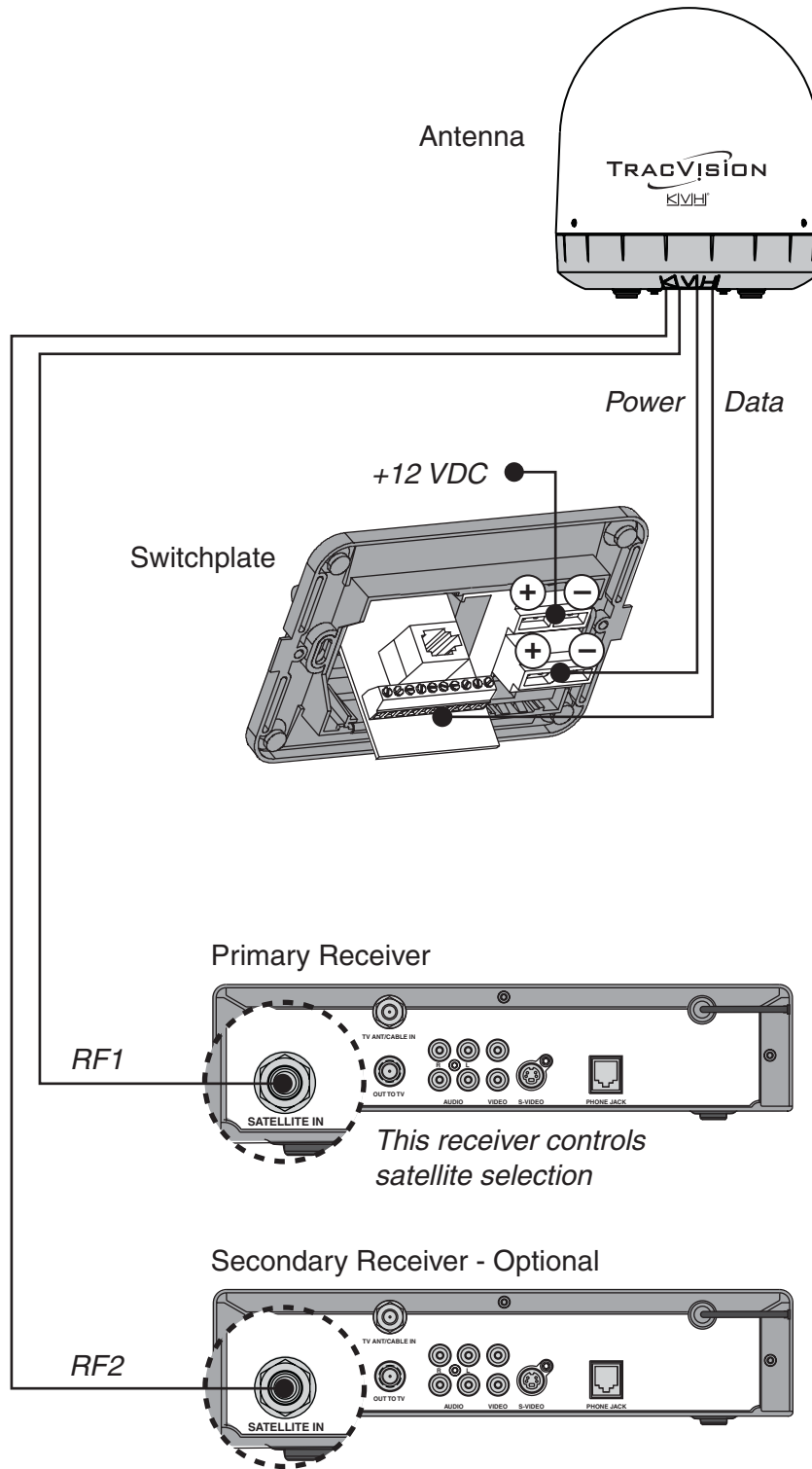

D Continued...

Wiring Three or Four Receivers (Circular only)

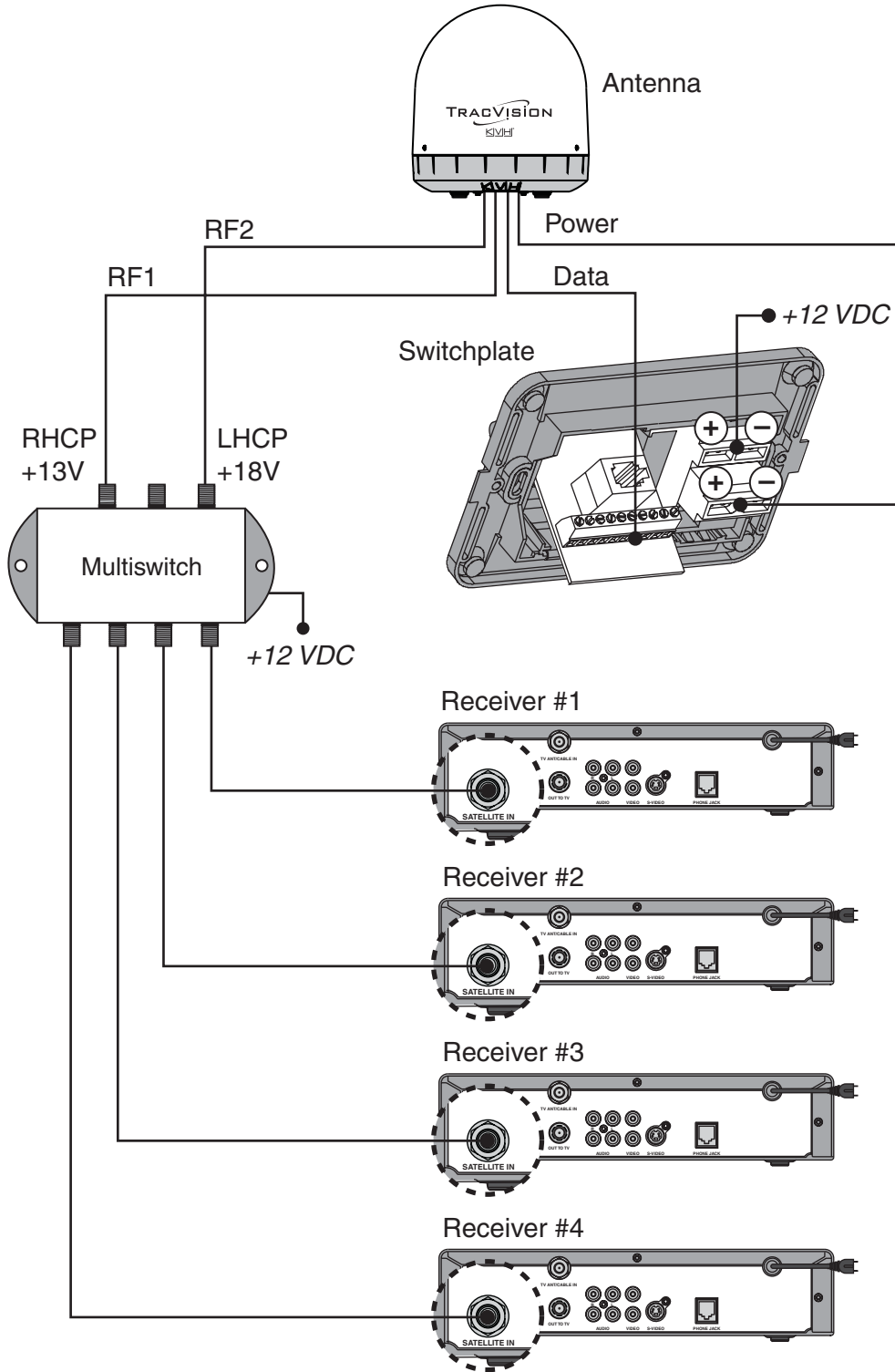

Switchplate Mounting Template

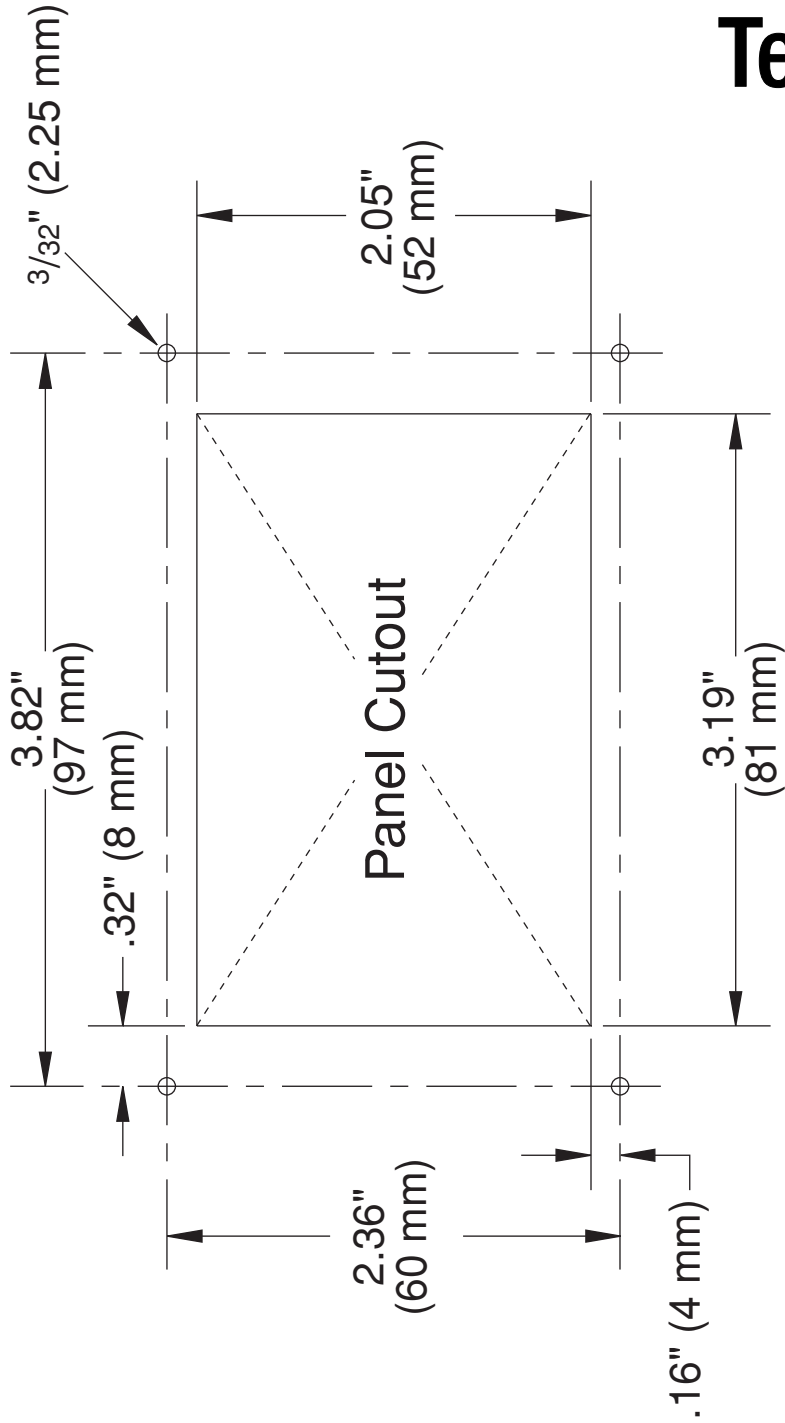



KVH Industries, Inc.

50 Enterprise Center Middletown, RI 02842-5279 U.S.A.
Phone: +1 401 847-3327 Fax: +1 401 849-0045
E-mail: info@kvh.com Internet: www.kvh.com

KVH Europe A/S

Kokkedal Industripark 2B 2980 Kokkedal Denmark
Phone: +45 45 160 180 Fax: +45 45 160 181
E-mail: info@kvh.dk Internet: www.kvh.com

Free Manuals Download Website

<http://myh66.com>

<http://usermanuals.us>

<http://www.somanuals.com>

<http://www.4manuals.cc>

<http://www.manual-lib.com>

<http://www.404manual.com>

<http://www.luxmanual.com>

<http://aubethermostatmanual.com>

Golf course search by state

<http://golfingnear.com>

Email search by domain

<http://emailbydomain.com>

Auto manuals search

<http://auto.somanuals.com>

TV manuals search

<http://tv.somanuals.com>