

14" Bandsaw w/Open Stand

Model: 10-321

RIKON

POWER TOOLS



Record the serial number and date of purchase
in your manual for future reference.

Serial number: _____

Date of purchase: _____

For more information:

www.rikontools.com or info@rikontools.com

For Parts or Questions:

techsupport@rikontools.com or 877-884-5167

Part #10-321M1

Owner's Manual









Operator Safety: Required Reading

IMPORTANT! Safety is the single most important consideration in the operation of this equipment. **The following instructions must be followed at all times.**

There are certain applications for which this tool was designed. We strongly recommend that this tool not be modified and/or used for any other application other than that for which it was designed. If you have any questions about its application, do not use the tool until you have contacted us and we have advised you.

General Safety Warnings

KNOW YOUR POWER TOOL. Read the owner's manual carefully. Learn the tool's applications, work capabilities, and its specific potential hazards.

 ⚠ DANGER	ALWAYS GROUND ALL TOOLS. If your tool is equipped with a three-pronged plug, you must plug it into a three-hole electric receptacle. If you use an adapter to accommodate a two-pronged receptacle, you must attach the adapter plug to a known ground. Never remove the third prong of the plug. ALWAYS AVOID DANGEROUS ENVIRONMENTS. Never use power tools in damp or wet locations. Keep your work area well lighted and clear of clutter.
 ⚠ DANGER	ALWAYS REMOVE THE ADJUSTING KEYS AND WRENCHES FROM TOOLS AFTER USE. Form the habit of checking to see that keys and adjusting wrenches are removed from the tool before turning it on. ALWAYS KEEP YOUR WORK AREA CLEAN. Cluttered areas and benches invite accidents.
 ⚠ DANGER	ALWAYS KEEP VISITORS AWAY FROM RUNNING MACHINES. All visitors should be kept a safe distance from the work area. ALWAYS MAKE THE WORKSHOP CHILDPROOF. Childproof with padlocks, master switches, or by removing starter keys.
 ⚠ DANGER	NEVER OPERATE A TOOL WHILE UNDER THE INFLUENCE OF DRUGS, MEDICATION, OR ALCOHOL.
 ⚠ DANGER	ALWAYS WEAR PROPER APPAREL. Never wear loose clothing or jewelry that might get caught in moving parts. Rubber-soled footwear is recommended for the best footing.
 ⚠ DANGER	ALWAYS USE SAFETY GLASSES AND WEAR HEARING PROTECTION. Also use a face or dust mask if the cutting operation is dusty.
 ⚠ DANGER	NEVER OVERREACH. Keep your proper footing and balance at all times.
 ⚠ DANGER	NEVER STAND ON TOOLS. Serious injury could occur if the tool is tipped or if the cutting tool is accidentally

▲ DANGER**ALWAYS DISCONNECT TOOLS.**

Disconnect tools before servicing and when changing accessories such as blades, bits, and cutters.

**ALWAYS AVOID ACCIDENTAL STARTING.**

Make sure switch is in "OFF" position before plugging in cord.

NEVER LEAVE TOOLS RUNNING UNATTENDED.**▲ DANGER****ALWAYS CHECK FOR DAMAGED PARTS.**

Before initial or continual use of the tool, a guard or other part that is damaged should be checked to assure that it will operate properly and perform its intended function. Check for alignment of moving parts, binding of moving parts, breakage of parts, mounting, and any other conditions that may affect its operation. A guard or other damaged parts should immediately be properly repaired or replaced.



Special Safety Rules For Bandsaws

1. Always allow the Bandsaw blade to stop before removing scrap pieces from table.
2. Always keep hands and fingers away from the blade.
3. Never attempt to saw stock that does not have a flat surface, unless a suitable support is used.
4. Always hold material firmly and feed it into the blade at a moderate speed.
5. Always turn off the machine if the material is to be backed out of an uncompleted cut.
6. Adjust the upper guide about 1/8" above the material being cut.
7. Check for proper blade size and type for thickness and type of material being cut.
8. Make sure that the blade tension and blade tracking are properly adjusted.
9. Make "relief" cuts before cutting long curves.
10. Release blade tension when the saw will not be used for a long period of time.

California Proposition 65 Warning

WARNING: Some dust created by power sanding, sawing, grinding, drilling, and other construction activities contains chemicals known to the State of California to cause cancer and birth defects or other reproductive harm. Your risk from exposure to these chemicals varies, depending on how often you do this type of work. To reduce your exposure, work in a well-ventilated area and with approved safety equipment, such as dust masks that are specially designed to filter out microscopic particles.

For more detailed information about California Proposition 65 log onto rikontools.com.

Note: This owner's manual is not a teaching aid. Use of this owner's manual is intended to show assembly, adjustments, and general use.

SAVE THESE INSTRUCTIONS.
Refer to them often.

Table of Contents



Safety Warnings.....	2-3
Bandsaw Safety Rules	3
Specifications	4
Contents of Package	5
Loose Parts	5
Stand Assembly	6
Table Assembly	6-7
Tool Holder/Dust Port Assembly	7
Know Your Bandsaw.....	8
Adjustments	8
Centering the Table	8
Squaring Table to Blade	8
Setting Table Square at Back of Blade.....	9
Tilting the Table.....	9
Changing the Bandsaw Blade.....	9
Adjusting Blade Tension.....	9
Tracking the Saw Blade.....	9
Adjusting the Cutting Height	10
Upper Blade Guide Adjustment	10
Lower Blade Guide Adjustment	10
Changing Blade Speed	10-11
Setting Drive Belt Tension.....	11
Operation	12
Maintenance	13
Wiring Diagram	13
Troubleshooting	14
Parts Diagrams/Lists	15-25
Notes.....	26
Espanol.....	27-49
How To Guide	50
Warranty	51

Specifications

Throat Width	13-5/8" (346 mm)
Max. Cutting Depth	8" (204 mm)
Blade Length	99-3/4" (2534 mm)
Blade Width	1/4" – 3/4"(6-19 mm)
Table Size	15-3/4" x 20-3/8" (400 mm x 518 mm)
Table Tilt	Left-10° Right-45°
Blade Speeds	1620/3340 ft/min
Motor	1 HP
Amps/Speed	9/4.5 A / 1700 RPM
Volts	120/240V
Net weight	160 lbs

ASSEMBLY

1. TOOLS REQUIRED FOR ASSEMBLY

Item	Description	Qty.
	Phillips Screwdriver.....	1
	Adjustable Wrench.....	1
	Square.....	1

2. UNPACKING AND CHECKING CONTENTS

Model 10-321 14" Band Saw is shipped complete in one box.

A. Separate all parts from carton and check each item with Carton Contents list below to make sure all items are accounted for, before discarding any packing material.











B. Remove the protective oil that is applied to the table. Use any ordinary household type grease and spot remover.

C. Apply a coat of paste wax to the table to prevent rust. Wipe all parts thoroughly with a clean dry cloth.

CARTON CONTENTS

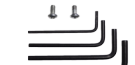
Item	Description	Qty.
A	Main Machine w/Blade Installed.....	1
B	Table.....	1
C	Package Containing Open Stand	1
D	Bag of Loose Parts for Main Machine.....	1
E	Upper Table Trunnion Assembly.....	1
F	Bag of Loose Parts for Stand.....	1
G	Operator's Manual.....	1

LIST OF LOOSE PARTS IN BAG

Item	Description	Qty.
	2-1/2" Dust port.....	1
	Hex Socket head cap screw M6x12.....	2
	Washer 6.....	2
	Blade tension knob.....	1
	Crank handle.....	1
	Hex Nut M6.....	2
	Hex Bolt M8x35.....	1
	Hex Nut M8.....	1
	Wing nut M6.....	1
	Tube.....	1
	Washer 6.....	1
	Hex Socket head cap screw M6x45.....	1
	Tool holder.....	1
	Pan head screw M5x10.....	2
	M2.5 Hex "L" Wrench.....	1
	M3 Hex "L" wrench.....	1
	M4 Hex "L" wrench.....	1
	M5 Hex "L" wrench.....	1
	Hex Bolt, washer, nut assembly M8.....	24
	Hex Bolt, washer, nut assembly M6.....	4
	Rubber foot.....	4
	Hex Bolt M8x16.....	4
	Lock washer 8.....	4



A

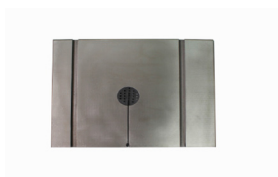

B



C



D



E



F



G

3. INITIAL ASSEMBLY

The 10-321 band saw is supplied partly assembled. Prior to use, the following items have to be assembled: Open Stand, 2-1/2" Dust Port, Table, Blade Tension Knob, Tool Holder, and Crank Handle.

WARNING: To avoid injury, do not attempt to run or use this machine until all parts are assembled and working properly.

A. Open Stand Assembly

- Check contents against the parts list.

Hint: All front and side panels assemble behind (inside) leg pieces.

- Fasten front panel on to paired legs, using hex carriage bolts, washers and hex nuts. Do not fully tighten.
- Fasten side panel on to front panel and paired leg assemblies using remaining hex carriage bolts, washers and hex nuts.
- Fasten the front and side beams on the paired legs with hex carriage bolts, washers and hex nuts.
- Set stand in an upright position, ensuring that the holes on the top edge of the panels line up sufficiently to allow hex head screws to pass through. Fully Tighten the hex carriage bolts and hex nuts.
- Press rubber feet onto the end of stand legs.
- With the aid of an assistant, lift band saw and carefully position in place on top of stand.
- Install base to stand using hex head screw (11) and washer (10) through stand and saw base, then washer (10) and hex nut (9) on top of saw base. Repeat procedure for all four corners before tightening fully.

WARNING: To Avoid back injury, get help lifting the band saw. Bend your knees, and lift with your legs, not your back.

Parts List		
Item No.	Description	Qty
1	Front beam	2
2	Side beam	2
3	Legs	4
4	Side panel	2
5	Front panel	2
6	Hex nut	24
7	Washer	24
8	Hex carriage bolt	24
9	Hex nut	8
10	Washer	8
11	Hex head screw	4
12	Rubber foot	4
13	Washer	4

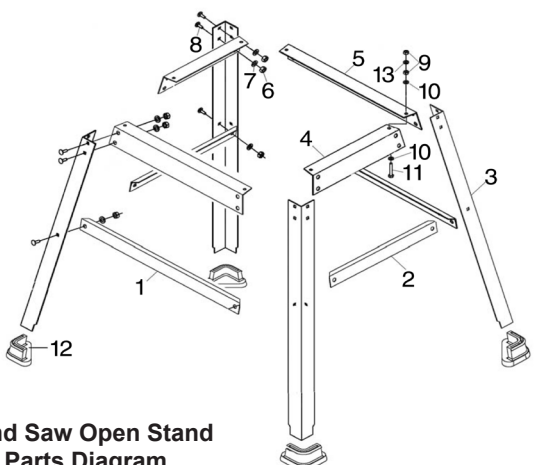

**Band Saw Open Stand
Parts Diagram**

B. Assemble the 2-1/2" dust port to the band saw frame with Hex socket head cap screw and washer. Place the 2-1/2" dust port onto the side of the band saw frame.

Locate two Hex socket head cap screws and two washers from the bag of loose parts. Mount the dust port to the band saw frame and install a Hex socket head cap screw with washer in each hole, then tighten with M5 Hex "L" wrench. (See FIG. 1)

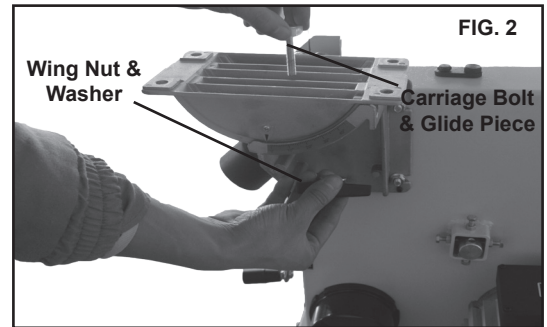
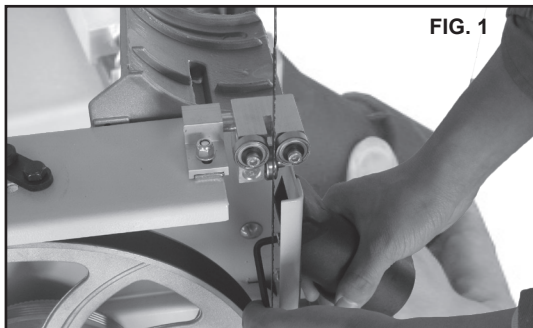

D. Place the table onto the upper table trunnion. Carefully feed the blade through the slot of the table. (See FIG. 2A)

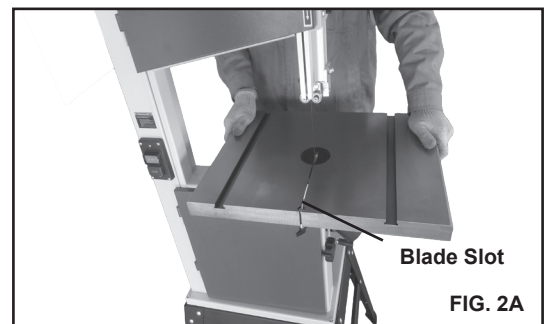

C. Assemble the upper table trunnion to the lower table trunnion with Carriage Bolt, Glide Piece, Washer and Wing Nut (See FIG. 2).

E. Locate four hex bolts and four lock washers from the bag of loose parts used to mount the table. Mount the table to the upper table trunnion and install a bolt with washer in each hole, then tighten with a 13mm wrench. (See FIG. 3)

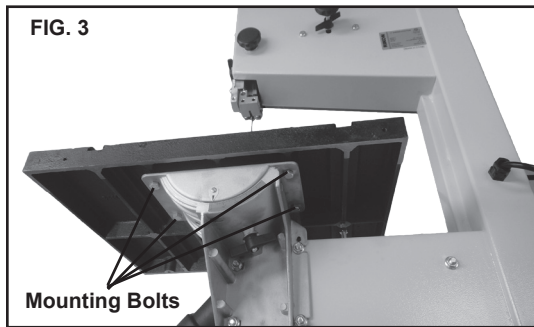

F. Next locate one Hex Bolt M8x45 and one Hex Nut M8. Install under the table as shown. This assembly is used to level the table. (See FIG. 4)

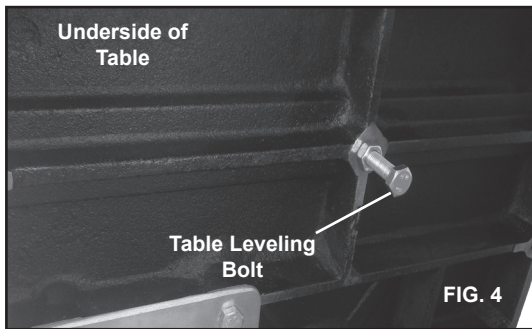

G. Use the hex socket head cap screw, washer, bushing and wing nut for correcting the working table flatness. (See FIG. 5)

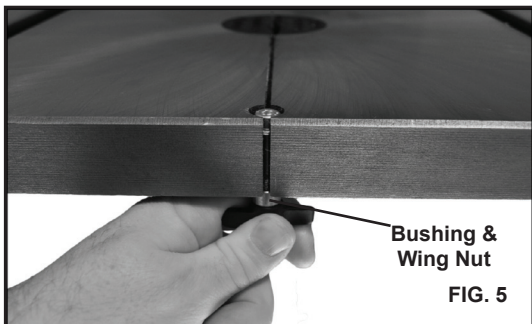

H. Attach the crank handle to the belt tension crank arm with the M6 Hex nut. (See FIG. 6)



I. Assemble the tool holder to the column of the band saw with two pan head screws. Locate two pan head screws from the bag of loose parts. Mount the tool holder to the column and install a pan head screw in each hole, then tighten with Phillips screwdriver. (See FIG. 7)

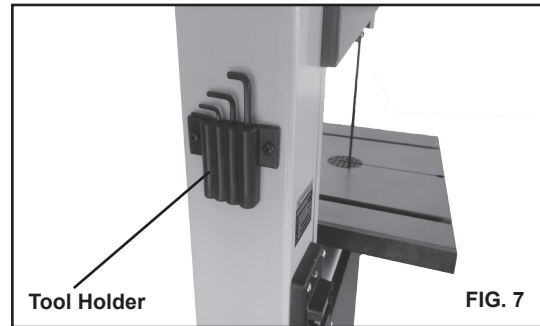

J. Place the blade tension knob onto the blade tension assembly. (See FIG. 8)

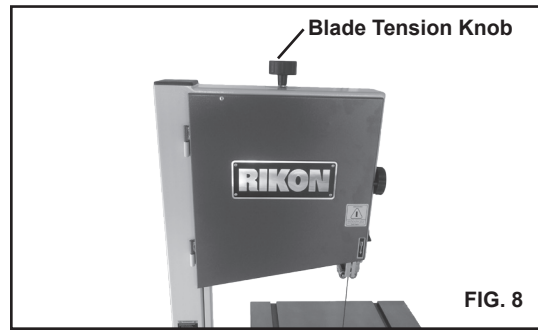

K. The band saw has a 2-1/2" dust port and 4" dust port included for connection to standard width shop vacuum hoses. (See Fig. 9) It is recommended that when in use, the band saw is connected to a suitable dust collector.

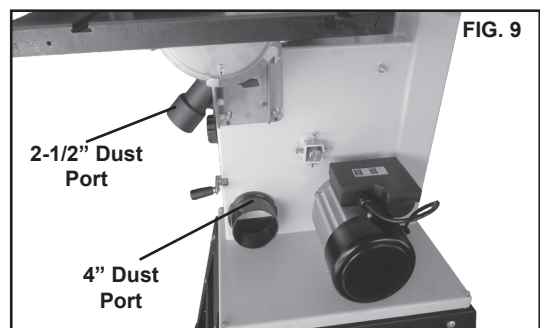

KNOW YOUR BAND SAW

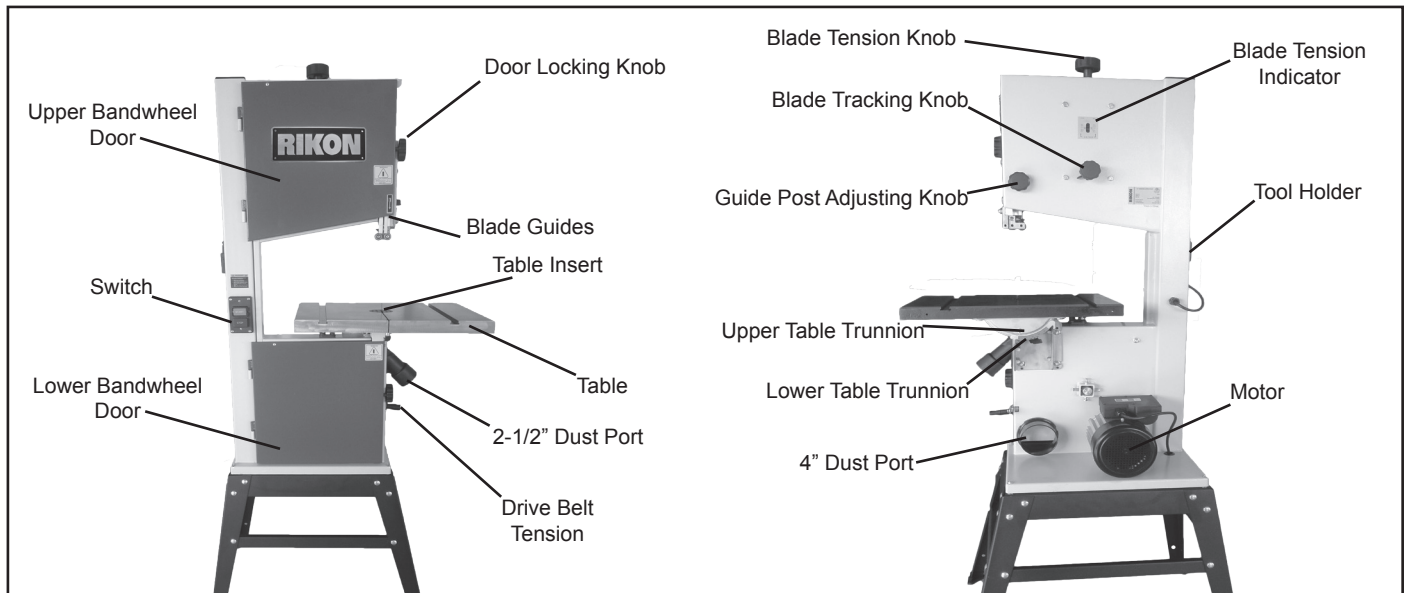

ADJUSTMENTS

1. CENTERING THE TABLE

A. Loosen the four Hex bolts mounting the table to the upper table trunnion. (See FIG. 10)

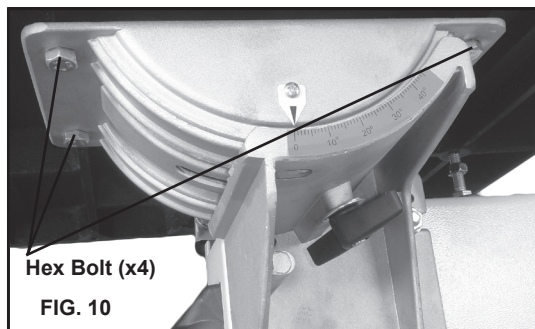

- B.** Move the table sideways as required, until the saw blade runs through the center of the table insert.
C. If the adjustment of "B" is not enough to center the table, loosen the four flange nuts holding the lower table trunnion and move the table sideways to place the table in the center.
D. Re-tighten Hex bolts for trunnion; recheck the saw blade position.

2. SETTING TABLE SQUARE TO SAW BLADE ON RIGHT AND LEFT POSITION

Loosen the wing nut on the lower table trunnion and place a suitably sized square against the saw blade on right and left position. If the table requires adjustment, proceed as follows:

- A.** Using a wrench, release the Hex nut under the table. (See FIG. 11)
B. Place the wrench on the Hex bolt and adjust until the table is square to the saw blade. (See FIG. 11)

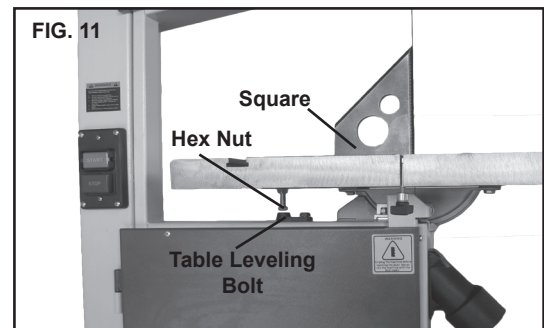

- C.** Tighten the Hex nut and check the saw blade and the table for square.
D. Lock the table into position and check that the indicator reads zero degrees on the side of lower table trunnion. Loosen the screw securing the indicator and reset if necessary to give zero degree reading. (See FIG. 12)

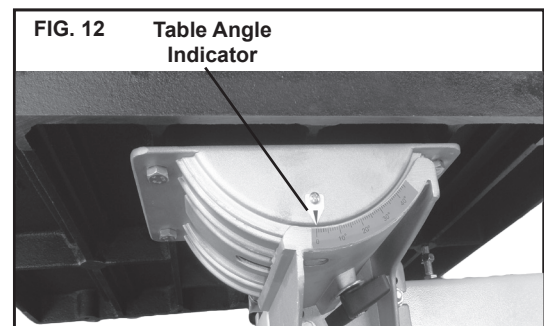

3. SETTING TABLE SQUARE BACK OF BLADE

Place a square against the back (non-tooth) side of the saw blade. If you find that the table runs up hill or down hill as you feed the work piece, proceed as follows:

- A. Using a wrench, release the flange nut on the lower table trunnion. (See FIG. 13)
- B. Place the M5 Hex "L" wrench on the Hex socket set screw and adjust until the table is square to the saw blade on the back (non-tooth) side of the saw blade.

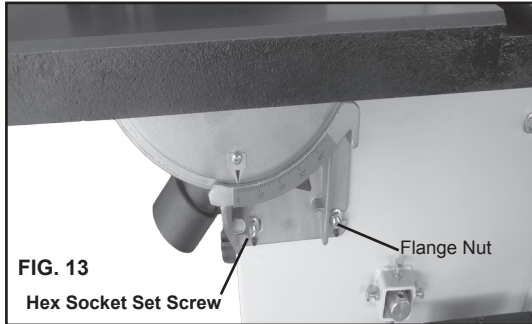

- C. Tighten the flange nut and recheck the saw blade and the table for square.

4. TILTING THE TABLE

For bevel cuts, the table tilts 0 through 45 degrees.

- A. To tilt the table, loosen the wing nut on the table trunnion, set the table to the required angle and tighten the wing nut again (See FIG. 14).

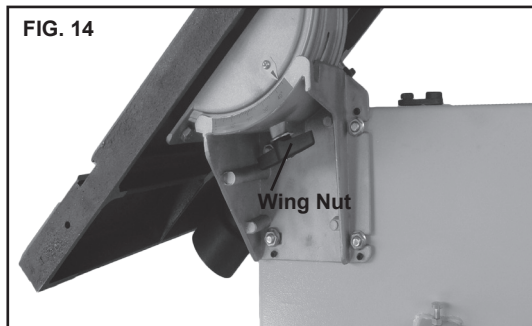

- B. It is recommended to verify the correct angle setting using an angle guide, or by making trial cuts in scrap wood. Adjust the indicator accordingly by using a phillips head screwdriver.

5. ADJUSTING THE BLADE TENSION

To loosen the tension of the blade, turn the blade tension knob counterclockwise and the tension indicator will lower. To tighten the tension of the blade, turn the tension knob clockwise, and the tension indicator will rise. (See FIG. 15)

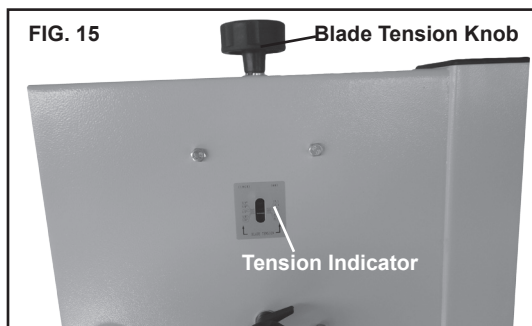

6. CHANGING AND ADJUSTING THE SAW BLADE

This band saw is factory-equipped with a general-purpose wood cutting blade, the saw blade is set prior to delivery. To change the saw blade; the following procedure must be followed:

WARNING: To avoid injury from unexpected starting, whenever changing the saw blade or carrying out adjustments, switch the band saw off and remove the power cord from the power outlet. To avoid injury to hands when handling the saw blade, wear gloves whenever necessary.

- A. Open the upper and lower doors by turning the door locking knobs.
- B. Loosen the blade tension by turning the blade tension knob on the top of the upper wheel housing counterclockwise until the saw blade has slackened (viewed from above) (See FIG. 16).
- C. Remove the saw blade from the upper and lower wheels.
- D. When installing the new saw blade ensure the blade teeth are pointing downwards and towards you at the position where the saw blade passes through the table.

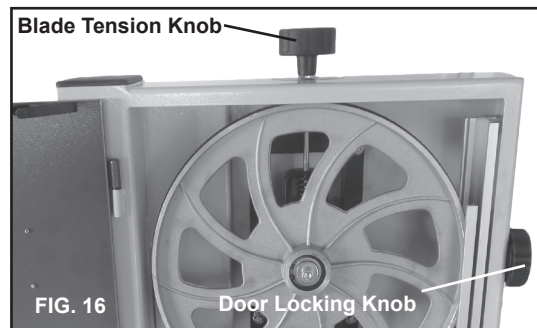

- E. Re-tension the new saw blade and check the saw blade tracking by turning the upper wheel by hand. The saw blade should run in the center of the band saw wheels.
- F. If needed adjust the tracking of the saw blade; proceed as mentioned below "TRACKING THE BAND SAW BLADE"
- G. Close the upper and lower doors by turning the door locking knobs before reconnecting the power supply.

7. TRACKING THE BAND SAW BLADE

Set the tracking of the saw blade before setting the blade guides. Once the saw blade is installed and tensioned, track the saw blade by adjusting the tracking knob by hand (See FIG. 17). The saw blade should run in the center of the band saw wheels. Use the blade tracking window to check position on wheel. When the correct adjustment is achieved lock the tracking knob with the wing nut.

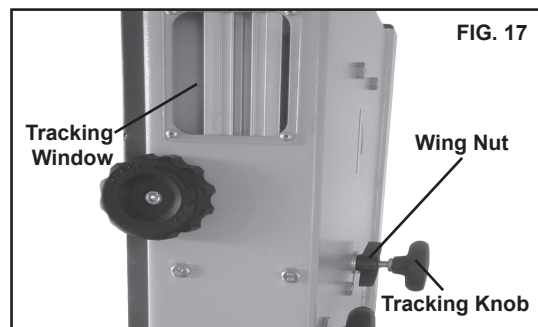

8. SETTING THE CUTTING HEIGHT

- A. The upper blade guide should be set as close as practical against the work piece.
- B. To adjust this height, loosen the wing nut at the side of the upper wheel housing. (See FIG. 18)
- C. Set the blade guide to the required height by turning the guide post adjusting knob.
- D. Tighten the wing nut after setting proper height.

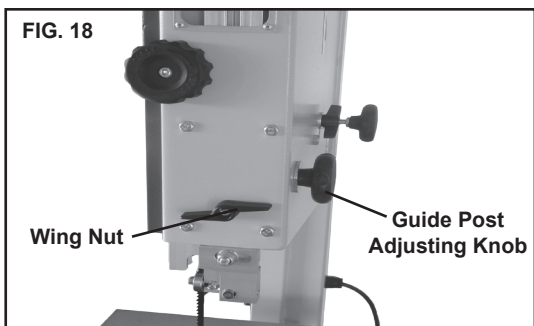

11. ADJUSTING THE BLADE GUIDES

The Upper Blade Guide

- A. To adjust the upper blade guides, first position the right and left roller guides relative to the blade by loosening the lock nut (FIG. 19) and moving the guide carrier until both roller guides are approximately 1/16" behind the gullets of the saw blade.
- B. Set both roller guides to within 1/32" of the saw blade by releasing the guide adjusting screw (FIG. 19) on each side of the saw blade and moving the guides to desired position. Lock the roller guide in position with the guide adjusting screw. Do not set the roller guides too close as this will adversely affect the life of the saw blade.

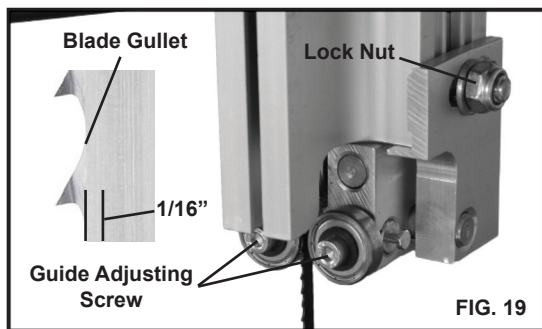

- C. Adjust the rear roller guide to be just clear of the back of the saw blade by releasing the guide adjusting screw FIG. 20 and moving the guide to approximately 1/32" behind the blade.
- D. When the correct adjustment is reached, lock the roller guide in position with the guide adjusting screw FIG. 20.



The Lower Blade Guide

- A. To adjust the lower blade guides, first position the right and left roller guides relative to the blade by loosening the lock nut (FIG. 21) and moving the guide carrier until both roller guides are approximately 1/16" behind the gullets (See Inset, FIG. 19) of the saw blade.
- B. Set both roller guides to within 1/32" of the saw blade by releasing the guide adjusting screw (FIG. 21) and moving the guide to desired position. Lock the roller guide in position with the guide adjusting screw. Do not set the roller guides too close as this will adversely affect the life of the saw blade.
- C. Adjust the rear roller guide to be just clear of the back of the saw blade by unlocking the guide adjusting screw (FIG. 21) and moving the guide to approximately 1/32" behind the blade.
- D. When the correct adjustment is reached, lock the roller guides in position with the guide adjusting screws.

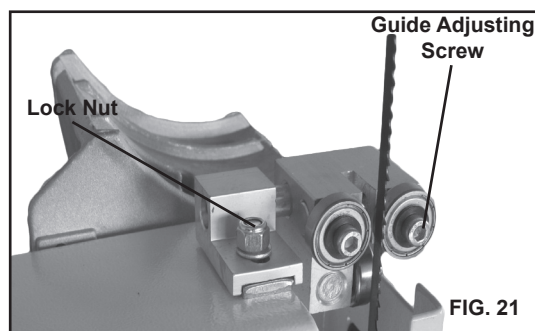

12. CHANGING THE BLADE SPEED

WARNING: Before changing the speed always make sure the machine has been unplugged from the electrical supply.

This band saw has two blade speeds:

- A. 1620 feet/min for hardwoods, some plastics and certain nonferrous metals.
- B. 3340 feet/min for all other timber.

The lower bandwheel has two, integral, multi-vee form pulleys and the motor shaft has a twin multi-vee form pulley.

The drive belt passes around the bandwheel pulley, the motor pulley and the tension wheel. The belt tension is released and applied by using the crank handle (See FIG. 22). This moves the tension wheel and allows the speed to be changed.

(See DRIVE BELT POSITIONS HIGH/LOW SPEED on page 11)

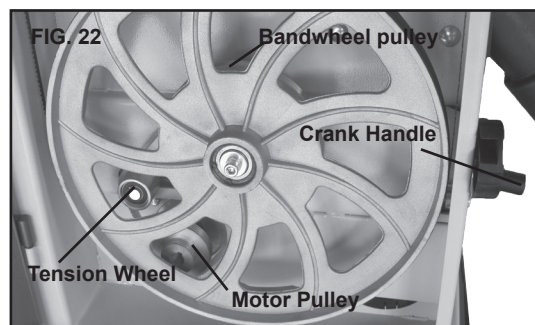

13. DRIVE BELT POSITIONS HIGH/LOW SPEED

A. For the low speed 1620 ft/min, fit the belt to the front pulley on both the motor and bandwheel. (See FIG. 23)

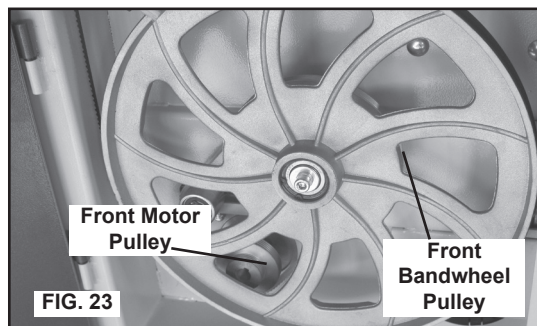

B. For the high speed 3340 ft/min, the belt should be fitted to the rear pulley on both the motor and bandwheel. (See FIG. 24)

Note: The rear bandwheel pulley is hidden from view.

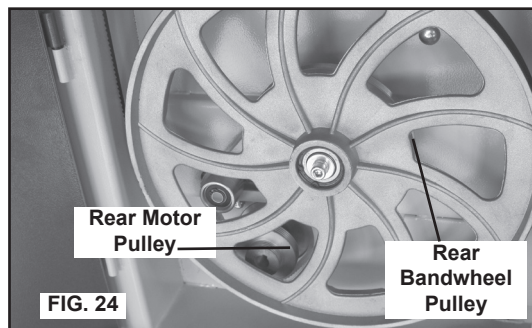

14. CHANGING THE DRIVE BELT

A. Release the saw blade tension by turning the blade tension knob on the top of band saw counterclockwise.

B. Release the belt tension by using the crank handle.

C. Using a hex wrench remove the hex socket head cap screw (See FIG. 25) from the center of the lower wheel.

D. Carefully slide the lower wheel forward and at the same time release the saw blade from the wheel.

E. Remove the old drive belt and fit the new belt (ensure ribs in drive belt are seated correctly before reassembling and tensioning the drive belt).

F. Follow procedures for CHANGING AND ADJUSTING THE SAW BLADE & TRACKING THE BAND SAW BLADE, before restoring power to the band saw and setting up for use.

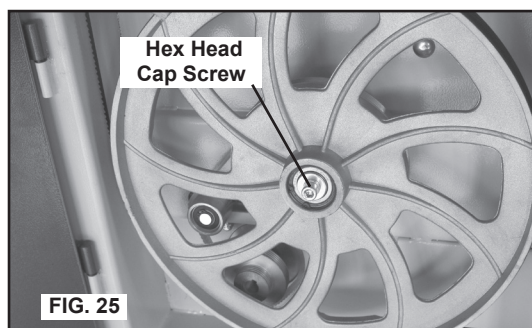

Drive Belt Tension:

Tension the drive belt using the crank handle until tight. Add/Remove tension until there is 1/2" to 3/8" side deflection.

OPERATION

WARNING: Before starting check if any part of your band saw is missing, malfunctioning, has been damaged or broken, such as the motor switch, or other operation control, a safety device or the power cord, turn the band saw off and unplug it until the particular part is properly repaired or replaced.

The saw blade cuts on a continuous downstroke. To avoid injury when hands are unavoidably near to the saw blade, they should be placed on either side of the blade (See FIG. 26), not in line with it (See FIG. 27). Use a push stick whenever possible when working in close proximity to the saw blade.

Start the band saw by pressing the green ON button (See FIG. 28) and wait for the band saw to come to full speed before starting to cut. Never start the band saw with the work piece in contact with the saw blade.

Slowly feed the work piece towards the saw blade, putting only light pressure on it. With both hands, firmly hold the work piece down on the table, and feed it towards the saw blade slowly.

Once the cutting operation is complete turn the band saw off by pressing the red STOP paddle on the switch.

For best results the saw blade must be sharp. Select the right saw blade for the job, depending on the thickness of the wood the cut to be made. The thinner and harder the wood, the finer the teeth (14 teeth per inch) of the saw blade. Use a fine tooth blade for cutting sharp curves. For thick wood cutting use less teeth, approximately 4 teeth per inch.

The machine is especially suited for cutting curves, but will also make straight cuts. Do not attempt to turn the work piece without pushing it, as this may cause the work piece to get stuck, or the saw blade to bend.

An accessory rip fence is used to ensure safe and accurate straight cuts of the work piece, usually in the same direction as the grain of the timber. Please see separate instructions provided in the accessory rip fence package.

WARNING: When sawing with the rip fence and a tilted table, the rip fence must be installed on that side of the table which is tilted downward.

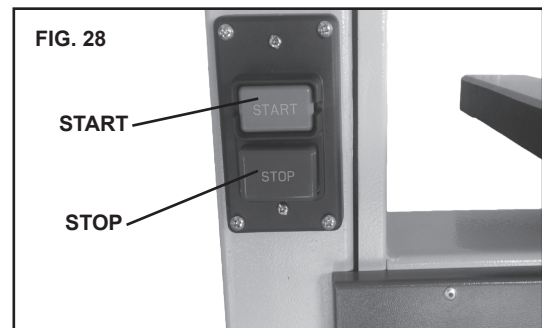
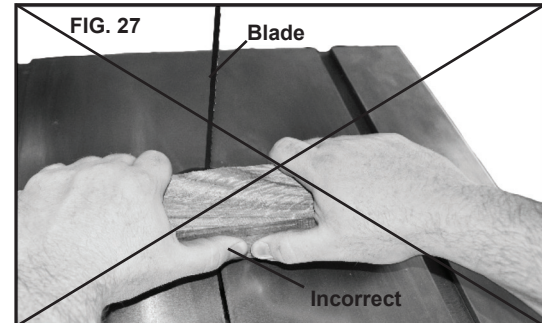
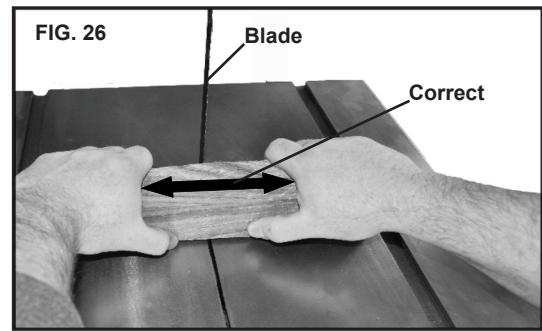

MAINTENANCE

WARNING: To avoid injury due to unexpected starting, before cleaning or carrying out maintenance work, switch off and disconnect the band saw from the power source.

Never use water or other liquids to clean the band saw. Use a dry brush.

Regular maintenance of the band saw will prevent unnecessary problems.

- A. Keep the table clean to ensure accurate cutting.
- B. Keep the outside of the machine clean to ensure accurate operation of all moving parts and prevent excessive wear.
- C. Keep the ventilation slots of the motor clean to prevent it from overheating.
- D. Keep the inside (near the saw blade, etc.) clean to prevent accumulation of dust (See FIG. 29 & 30). Use dust collection if possible.
- E. To prolong the life of the saw blade, when the band saw is not in use for extended periods, release the saw blade tension. Before reusing the band saw ensure that the blade is re-tensioned and tracking is checked.

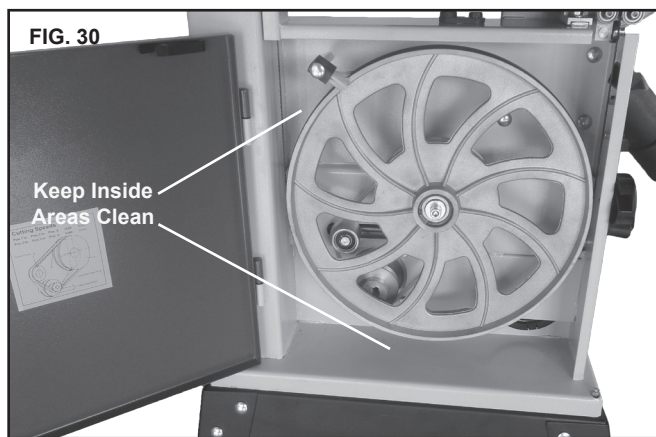
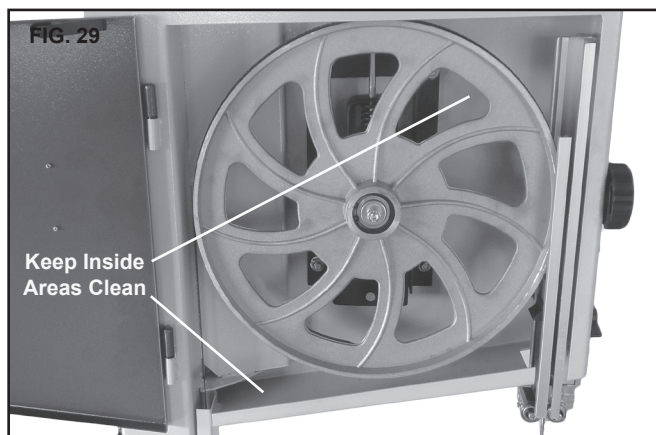

ELECTRICAL SCHEMATIC

WARNING: This machine must be grounded. To avoid electrocution or fire, any repairs to electrical system should be done only by a qualified electrician, using genuine replacement parts.

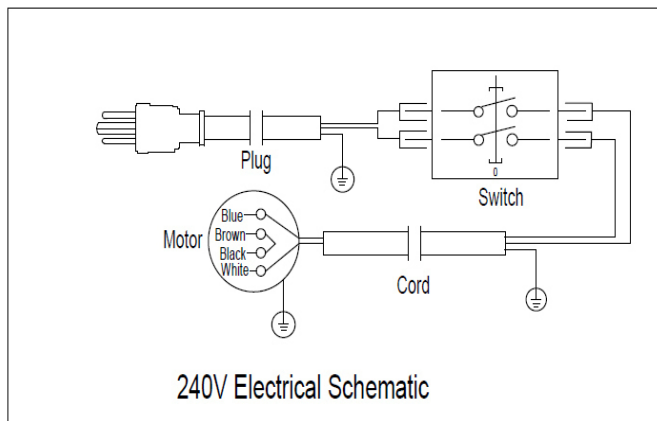
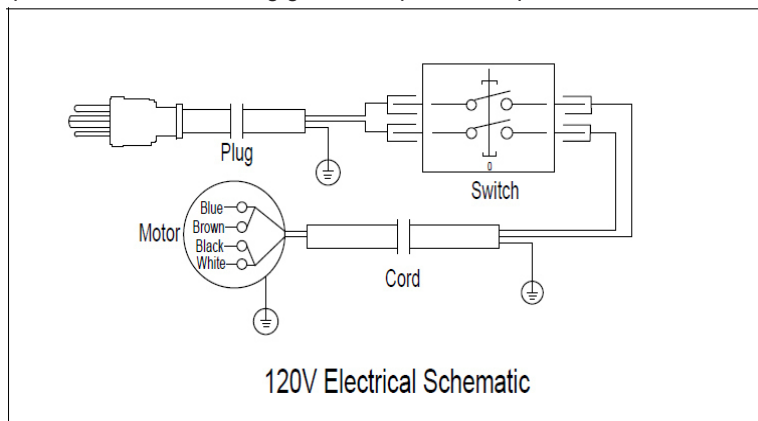

TROUBLESHOOTING

Problem	Diagnosis	Remedy
The machine does not work when switched on.	<ol style="list-style-type: none"> 1. No power supply. 2. Defective switch. 3. Defective motor. 	<ol style="list-style-type: none"> 1. Check the cable for breakage. 2. Replace the lock switch. 3. Defective motor.
The saw blade does not move with the motor running.	<ol style="list-style-type: none"> 1. The blade tension knob has not been tightened. 2. The blade has come off one of the wheels. 3. The saw blade has broken. 4. The drive belt has snapped. 	<ol style="list-style-type: none"> 1. Switch off the motor, tighten the blade tension knob. 2. Open the doors and check. 3. Replace the blade. 4. Replace the belt.
The saw blade does not cut in a straight line.	<ol style="list-style-type: none"> 1. Rip fence for cutting not used. 2. Feed rate too fast. 3. The blade teeth are dull or damaged. 4. Blade guides not suitably adjusted. 	<ol style="list-style-type: none"> 1. Use a rip fence. 2. Put light pressure on the work piece. Make sure the saw blade does not bend. 3. Try a new saw blade. 4. Adjust the blade guides (see ADJUSTMENT instructions).
The saw blade does not cut, or cuts very slowly.	<ol style="list-style-type: none"> 1. The teeth are dull, caused by cutting hard material or long use. 2. The saw blade was fitted the wrong way on the band saw. 	<ol style="list-style-type: none"> 1. Replace the saw blade, use a 6 T.P.I. (Teeth Per Inch) saw blade for wood and soft material. Use a 14 T.P.I. saw blade for harder materials. A 14 T.P.I. saw blade always cuts slower due to the finer teeth and the slower cutting performance. 2. Fit the saw blade correctly.
Sawdust builds up inside the machine.	This is normal	Clean the machine regularly. Open the doors and remove the sawdust with a vacuum cleaner.
Sawdust inside the motor housing.	This is normal	Clean the ventilating slots of the motor with a vacuum cleaner. From time to time remove the sawdust to prevent it from being drawn into the housing.
The machine does not cut at 45 or 90 degrees.	<ol style="list-style-type: none"> 1. The table is not at right angles to the blade. 2. The saw blade is dull or too much pressure was put on the work piece. 	<ol style="list-style-type: none"> 1. Adjust the table. 2. Replace the saw blade or put less pressure on the work piece.
The saw blade can not be properly positioned on the wheels.	<ol style="list-style-type: none"> 1. The wheels are not in alignment or defective bearing. 2. The blade tracking knob hasn't been properly adjusted. 3. Inferior saw blade. 	<ol style="list-style-type: none"> 1. Replace bearing. 2. Adjust the blade tracking knob (See ADJUSTMENT instructions). 3. Replace the saw blade.

PARTS DIAGRAM A

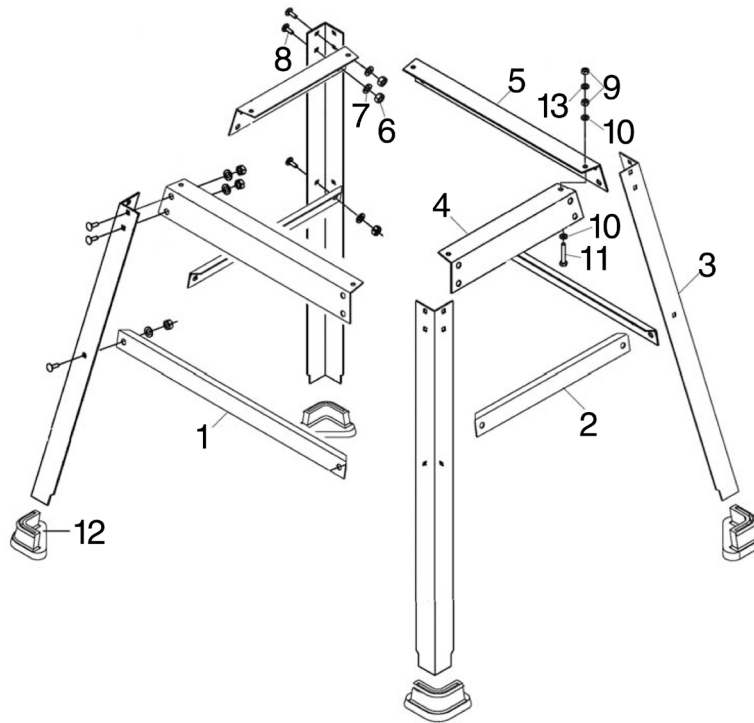

PARTS LIST A

KEY NO.	MFG. PART NO.	DESCRIPTION
1S	1-JL21050004-001Z	Front beam
2S	1-JL21050005-001Z	Side beam
3S	1-JL21050001-001Z	Leg
4S	1-JL21050003-001Z	Side panel
5S	1-JL21050002-001Z	Front panel
6S	1-NUT5/16B	Hex nut
7S	1-WSH8GB97D1B	Washer
8S	1-NEC5/16X5/8B	Hex bolt
9S	1-NUT1/4B	Hex nut
10S	1-WSH6GB96B	Washer
11S	1-HEX1/4X1 1/2B	Hex bolt
12S	1-JL40060005	Rubber shoe
13S	1-WSH6GB97D1B	Washer

PARTS DIAGRAM B

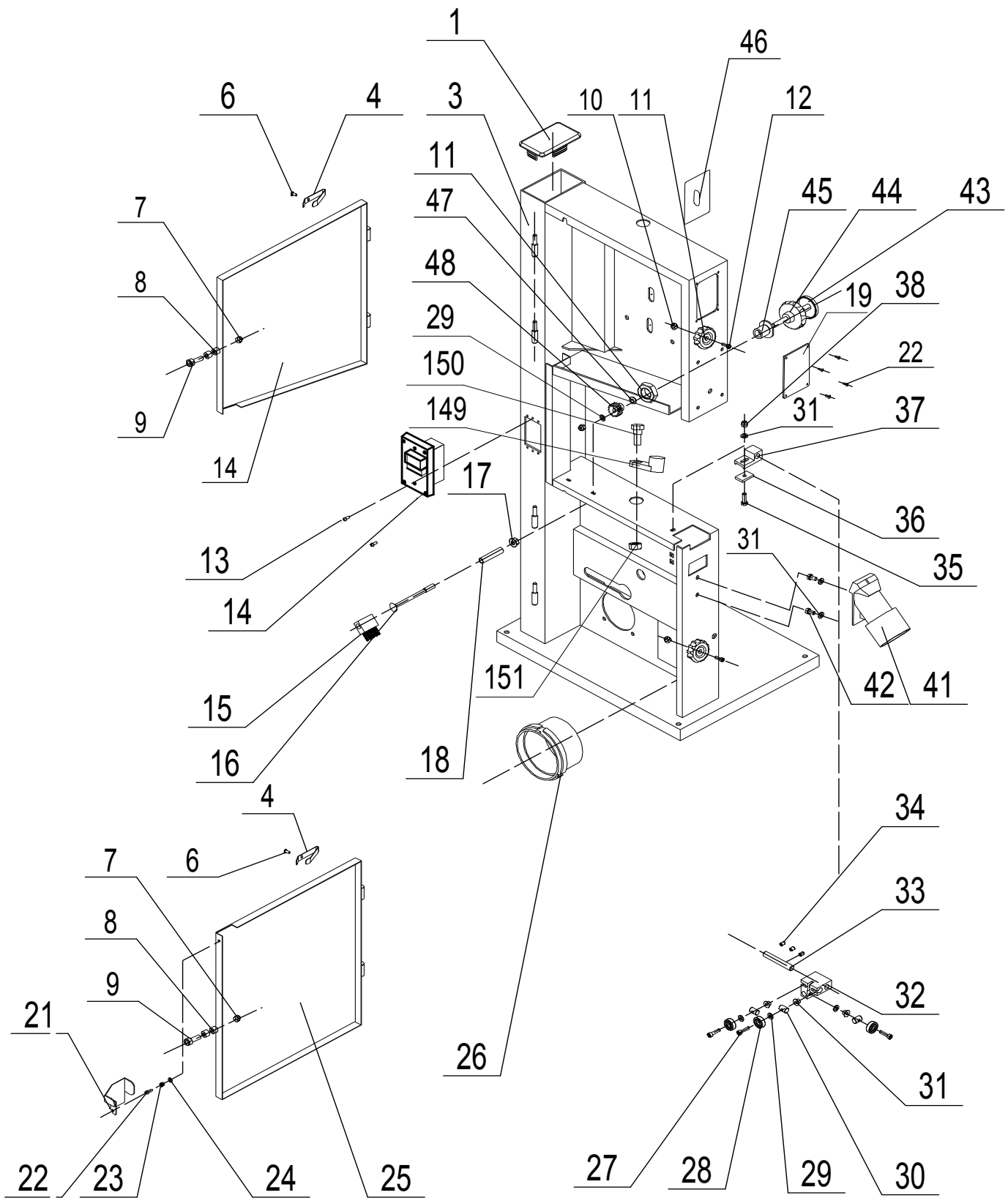

PARTS LIST B

KEY NO.	MFG. PART NO.	DESCRIPTION
1	1-JL21010001A-001S	Top plug
2	1-JL21011000R050W	Frame
3	1-JL20010008	Leaf spring
4	1-RVT4X8GB12618A	Rivet
5	1-M6GB889Z	Lock nut M6
6	1-JL26010007	Bushing
7	1-M6X25GB70Z	Hex socket screw M6X25
8	1-M6GB889Z	Lock nut M6
9	1-JL26010006-001S	Door locking knob
10	1-M6X22GB70Z	Hex Bolt M6X25
11	1-M20GB6173Z	Hex Nut M20
12	1-JL21012000J-049W	Upper door
13	1-M4X20GB818Z	Pan head screw
14	1-HY56	Switch
15	1-JL20010004	Brush
16	1-M8X100GB14Z	Carriage bolt M8X100
17	1-M8GB6177Z	Flange nut M8
18	1-JL20010003	Tube
19	1-JL26010001	Clear window
20	1-RVT3X7GB12618A	Rivet 3x7
21	1-JL20010006-050W	Blade Cover
22	1-M4X12GB818Z	Pan head screw
23	1-M4GB889Z	Lock nut M4
24	1-WSH4GB97D1Z	Washer
25	1-JL21013000D-049W	Lower door
26	1-JL20010007-001S	Dust port
27	1-M5X20GB70Z	Guide adjusting screw
28	1-BRG80018GB278	Bearing
29	1-WSH6GB97D1Z	Washer 6
30	1-JL22042004	Bearing mount cylinder
31	1-JL20042002	Bearing bushing
32	1-JL21042001	Upper guide mount
33	1-JL22043002	Lower guide shaft
34	1-M8X8GB80B	Hex Socket set screw M6x10
35	1-M6X20GB5783Z	Hex Bolt M6x20
36	1-JL20040001	Lower guide mount seat
37	1-JL21043001	Lower guide support
38	1-M6GB889Z	Lock nut M6
39	1-JL21010019	Dust port 2-1/2"
40	1-M6X12GB70D1Z	Hex bolt
41	1-JL20024001-001S	Adjusting knob cap
42	1-JL20044001-001S	Adjusting knob body
43	1-JL20044002	Tube
44	1-SR21020003	Ruler
45	1-JL22040003	Spring washer
46	1-JL22040001	Gear
149	1-JL21010014	Block
150	1-JL26010015	Threaded rod
151	1-M8GB889Z	Nut

PARTS DIAGRAM C

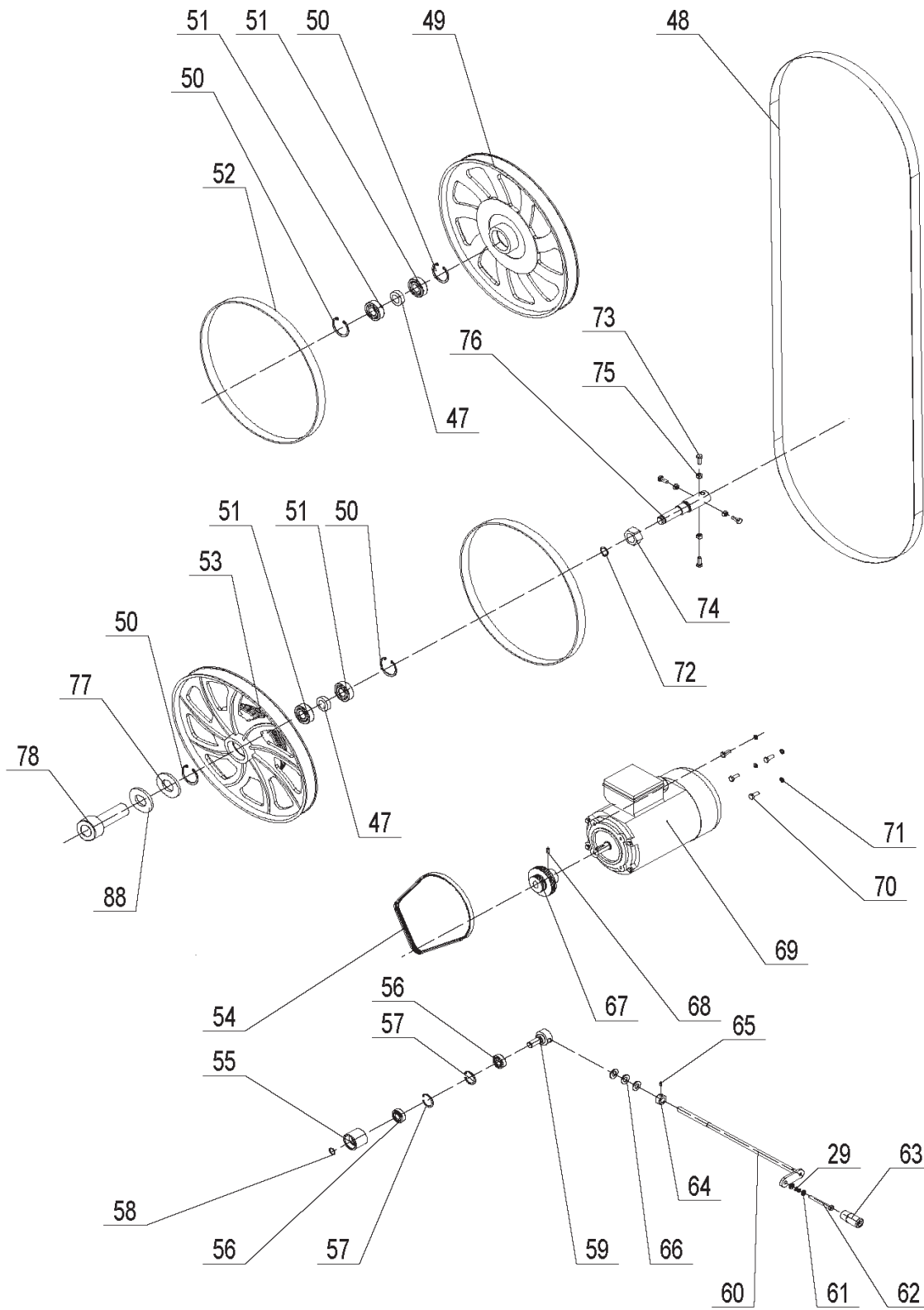

PARTS LIST C

KEY NO.	MFG. PART NO.	DESCRIPTION
47	1-JL28020004	Bushing
48	1-JL21020001K	Saw blade
49	1-JL21022001A	Upper wheel
50	1-CLP40GB893D1B	Retaining ring 40
51	1-BRG6203-2Z-P5GB276	Bearing
52	1-JL21022002A	Tire
53	1-JL21023002C	Lower wheel
54	1-JL20020002	Drive belt
55	1-JL20014002A	Tension wheel
56	1-BRG6001-2RSGB276	Bearing
57	1-CLP28GB893D1B	Retaining ring 28
58	1-CLP12GB894D1B	Retaining ring 12
59	1-JL20014001	Sliding shaft
60	1-JL21015100	Belt tension crank arm
61	1-M6GB6172Z	Hex Nut M6
62	1-M6X55GB65Z	Set screw M6X55
63	1-JL20015001-001S	Crank handle
64	1-JL20010015	Set collar
65	1-M5X8GB71Z	Set screw M5x8
66	1-WSH10GB97D1Z	Washer 10
67	1-JL20070001	Motor pulley
68	1-M6X10GB80B	Hex Socket set screw M6x10
69	2-YYH806084	Motor
70	1-M6X16GB9074D15Z	Hex bolt M6X16
71	1-WSH6GB93Z	Spring washer 6
72	1-CLP17GB894D1B	Retaining ring 17
73	1-M6X20GB5783Z	Hex Bolt M6x20
74	1-JL20020004	Special Hex Nut
75	1-M6GB6170Z	Hex Nut M6
76	1-JL21020002B	Lower bearing bolt
77	1-WSH8GB96Z	Washer 8
78	1-M8X16GB70Z	Hex Socket set screw M8X16
88	1-WSH8GB93Z	Spring washer

PARTS DIAGRAM D

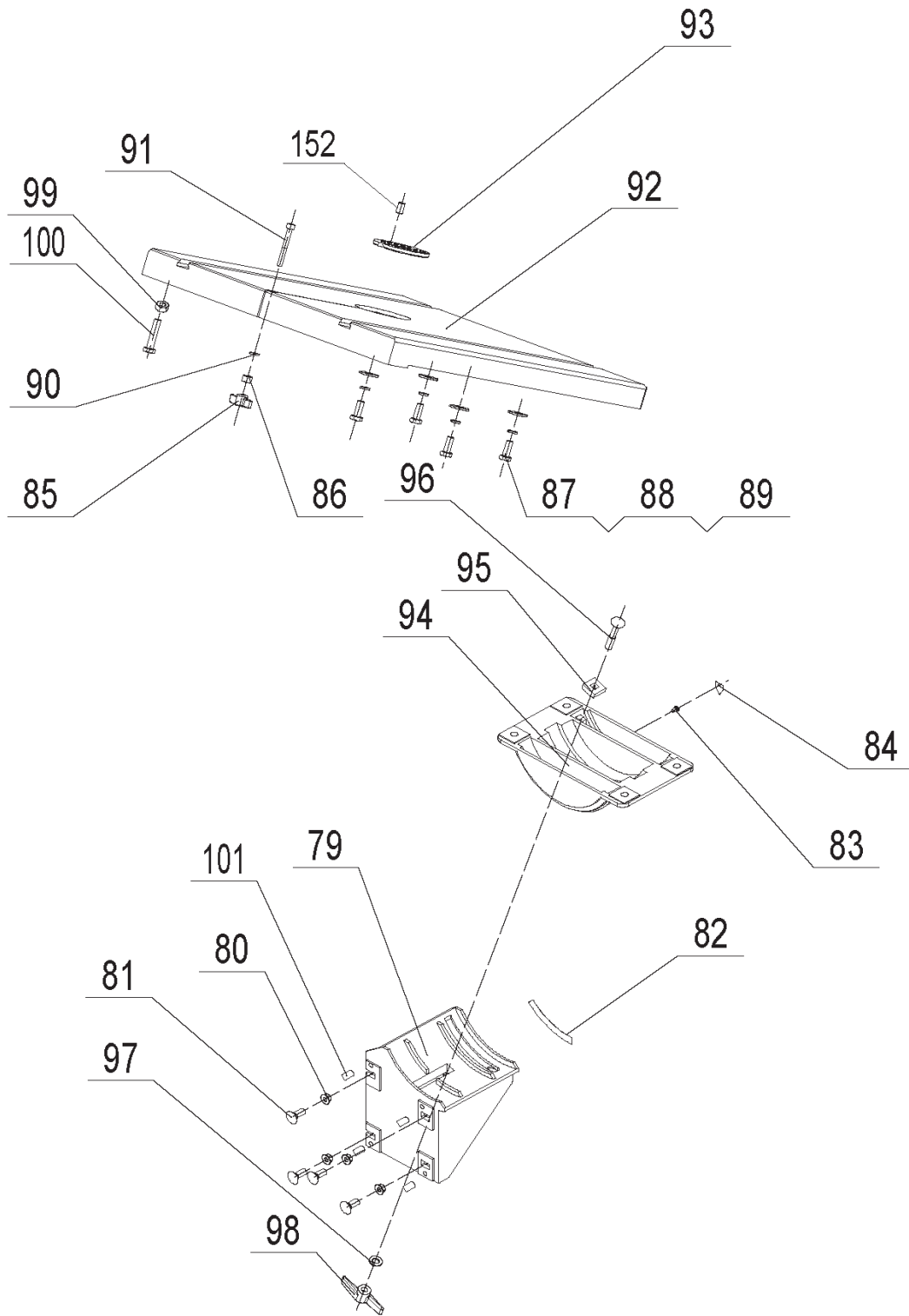

PARTS LIST D

KEY NO.	MFG. PART NO.	DESCRIPTION
79	1-JL20030001A	Lower table trunion
80	1-M8GB6177B	Flange nut M8
81	1-M8X20GB14Z	Carriage bolt M8x20
82	1-JL20030004	Turning label
83	1-ST3D5X9D5GB845Z	Tapping screw 3.5x9.5
84	1-1506003	Pointer
85	1-JL22020002-001S	Knob
86	1-JL21031003	Tube
87	1-M8X20GB5783Z	Hex bolt
88	1-WSH8GB93Z	Spring washer
89	1-WSH8GB96Z	Washer
90	1-WSH6GB97D1Z	Washer 6
91	1-M6X50GB70Z	Socket head bolt
92	1-JL21031001D001G	Table
93	1-JL20031002C-001S	Table insert
94	1-JL20032001	Upper table trunion
95	1-WSH8GB96Z	Washer 8
96	1-M8X50GB14Z	Carriage bolt M8x50
97	1-WSH8GB97D1Z	Washer 8
98	1-JL20010016-001S	Wing nut M8
99	1-M8GB6170Z	Nut
100	1-M8X40GB5783Z	Bolt
101	1-M6X10GB80B	Screw
152	1-M5X4GB80B	Screw

PARTS DIAGRAM E

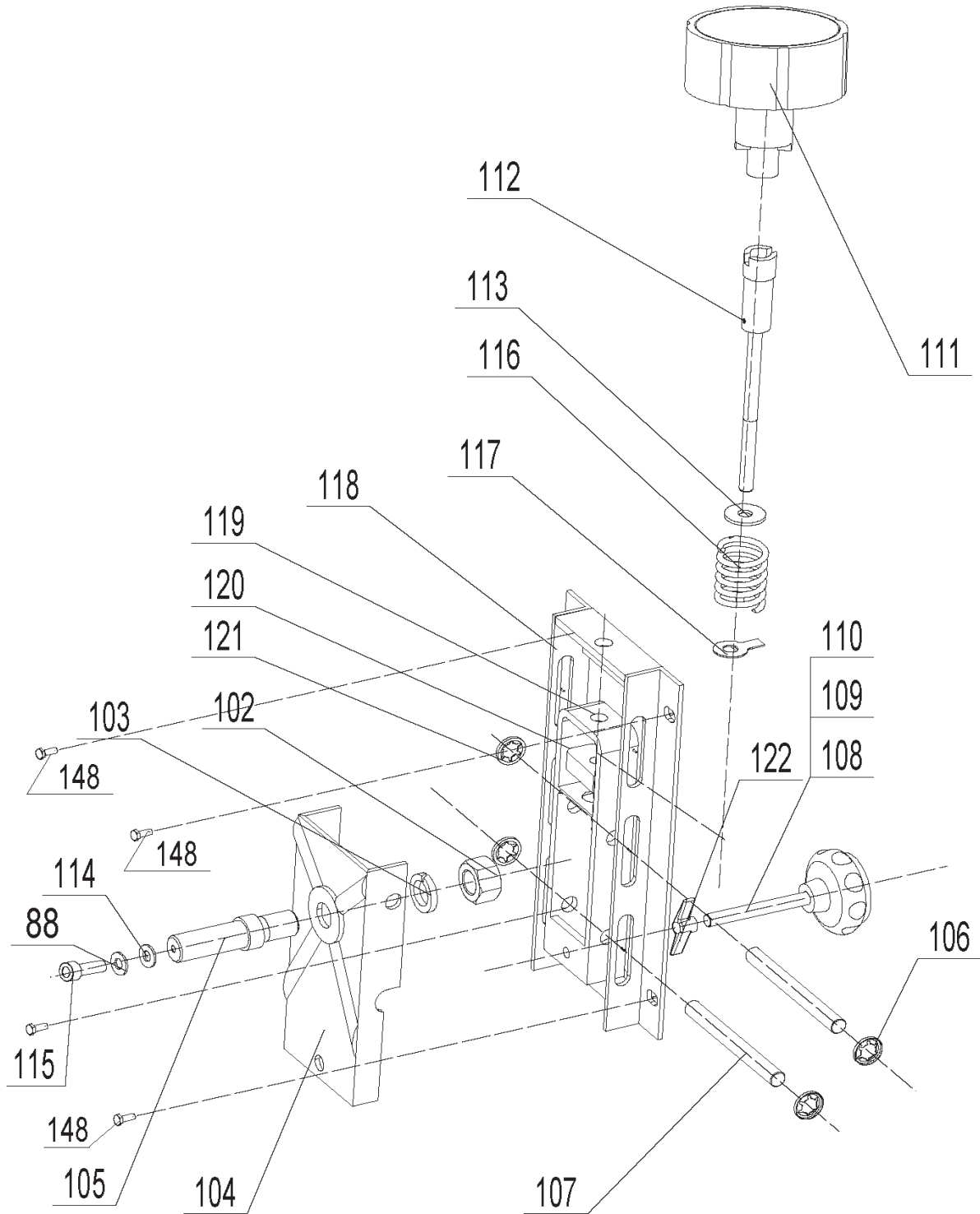

PARTS LIST E

KEY NO.	MFG. PART NO.	DESCRIPTION
88	1-WSH8GB93Z	Spring washer
102	1-M16GB6171Z	Hex Nut M16
103	1-WSH16GB93Z	Spring washer 16
104	1-JL20021005A001Z	Wheel carrier bracket
105	1-JL20021006D	Upper bearing bolt
106	1-JL20021004	Star lock
107	1-JL20021002	Mount shaft
108	1-JL20024001-001S	Adjusting knob cap
109	1-JL20024002-001S	Adjusting knob body
110	1-M8X70GB5781Z	Hex Bolt M8x70
111	1-JL21025000-001S	Blade tension knob
112	1-JL21021200A	Blade tensioner
113	1-JL20030002	Glide piece
114	1-WSH8GB96Z	Washer 8
115	1-M8X16GB70Z	Hex Socket set screw M8X16
116	1-JL21021010A	Spring
117	1-JL21020004-014T	Pointer
118	1-JL20021100A001Z	Tension bracket
119	1-JL20021001B001Z	Blade tensioner
120	1-JL20021009	Adjusting nut
121	1-JL20021004	Star lock
122	1-JL20010016-001S	Wing nut M8
148	1-M8X16GB5781Z	Hex Bolt

PARTS DIAGRAM F

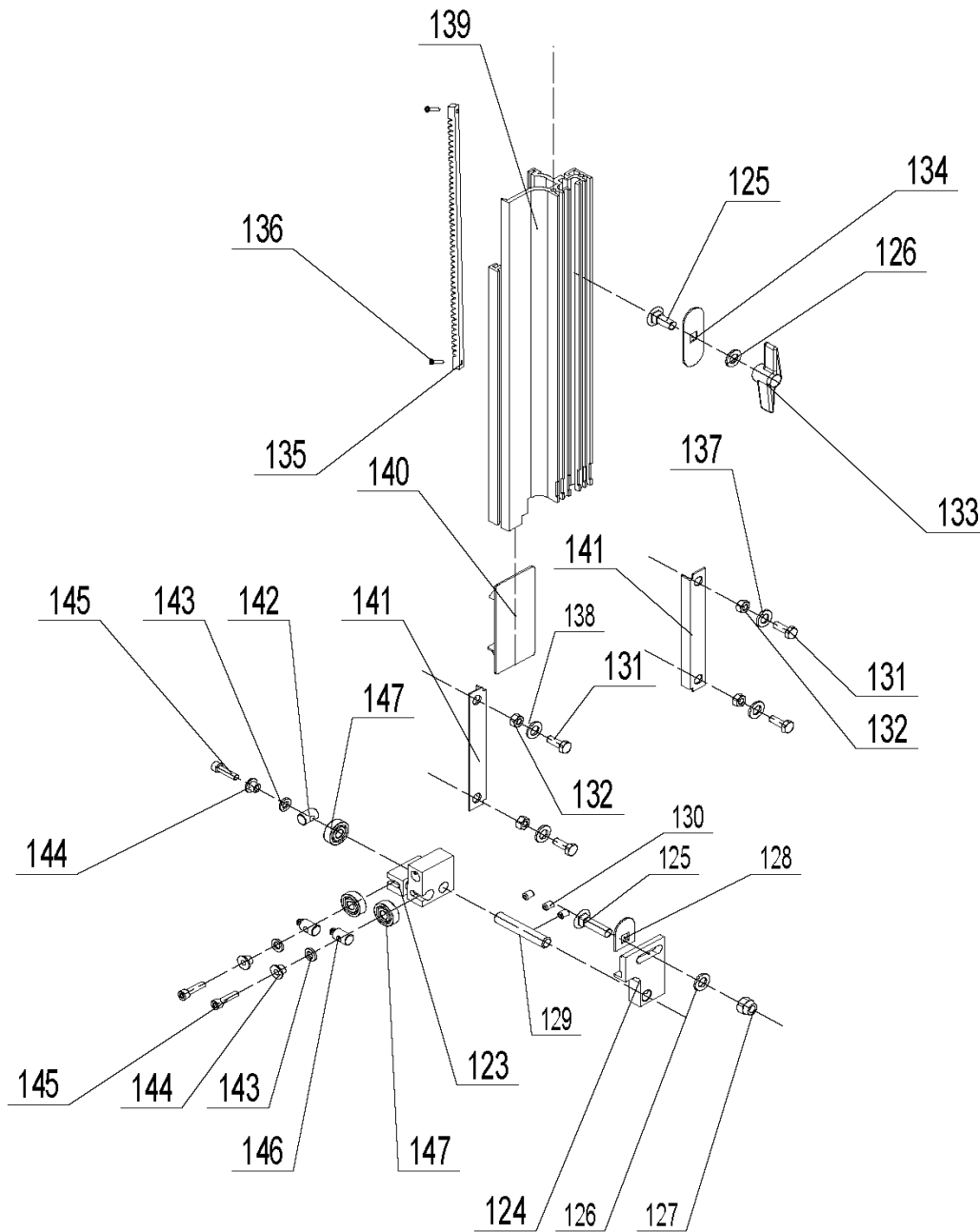

PARTS LIST F

KEY NO.	MFG. PART NO.	DESCRIPTION
123	1-JL21042001	Upper guide body
124	1-JL21042002	Upper guide mount
125	1-LOC5/16Z	Carriage bolt M8x20
126	1-WSH8GB97D1Z	Washer 8
127	1-NEC5/16X7/8	Hex nut
128	1-JL22041004	Special washer
129	1-JL22042002	Upper guide shaft
130	1-M6X10GB80B	Hex Socket set screw M6x10
131	1-M6X16GB5783B	Hex Bolt M6x16
132	1-M6GB6170Z	Hex Nut M6
133	1-JL20010016-001S	Wing nut M8
134	1-JL20041004	Bolt guide
135	1-JL20044003	Rack
136	1-ST3D5X13GB846Z	Tapping screw ST3.5x13
137	1-WSH6GB862D2B	Washer 6
138	1-WSH6GB862D2B	Washer 6
139	1-JL21041001F	Blade guide
140	1-JL21041002-001S	Slider
141	1-JL20010005	Guide bracket
142	1-JL22042004	Micro-adjusting knob
143	1-WSH6GB97D1Z	Washer 6
144	1-JL20042002	Bushing
145	1-M5X20GB70Z	Guide adjusting screw
146	1-JL22042003	Micro-adjusting knob
147	1-BRG80018GB278	Bearing

Lista de Contenido

Garantía.....	26
Las instrucciones de seguridad.....	26-28
Especificaciones.....	28
Asamblea.....	28-31
Conocer a su banda Vio.....	31
Ajuste.....	31-35
Operación.....	36
Mantenimiento.....	37
Esquema Eléctrico.....	37
Localizador de Averías.....	38
Partes Diagramas.....	38-49

Plena GARANTÍA DE UN AÑO

Durante cinco años a partir de la fecha de compra, este producto está garantizado contra defectos en los materiales o la mano. Un producto defectuoso recibirá la reparación o sustitución gratuita si la reparación no está disponible. Para los detalles de la cobertura de garantía para obtener la reparación o sustitución gratuita, visite el sitio web: www.rikontools.com Esta garantía no cubre la hoja, guías de la hoja y se inserta en el listado, que son piezas consumibles que pueden gastarse por el uso normal dentro del periodo de garantía.

LAS INSTRUCCIONES DE SEGURIDAD

PRECAUCIONES DE SEGURIDAD GENERAL

Conoce su herramienta ELÉCTRICA. **Lea el manual de instrucciones cuidadosamente. Aprender las aplicaciones de la herramienta, capacidades para el trabajo, y sus posibles peligros específicos.**

⚠ DANGER



Siempre Suelo Todas las herramientas.

Si el instrumento está equipado con un triple plug, debe conectar en una de tres hoyos recipiente eléctrico. Si utiliza un adaptador para acomodar un doble recipiente, debe adjuntar el adaptador a un terreno conocido. Nunca elimine la tercera clavija del enchufe.

Siempre evitar situaciones peligrosas.

Nunca utilice herramientas eléctricas en lugares húmedos o mojados. Mantener su área de trabajo bien iluminado y claro de desorden.

⚠ DANGER



Siempre retire la adaptación llaves y llaves de herramientas después de su utilización.

Constituyen la costumbre de comprobar que las claves y el ajuste llaves se quitan de la herramienta antes de encenderlo.

Siempre mantenga su área de trabajo limpia. Amontonado ámbitos y bancos invitamos a accidentes.

⚠ DANGER



Siempre mantenga los visitantes Lejos de máquinas para correr.

Todos los visitantes deben mantenerse una distancia segura de la zona de trabajo.

Siempre hacer el Taller Picaportes.

Picaportes con candados e interruptores maestros, o eliminando starter claves.

⚠ DANGER



Nunca opere una herramienta bajo la influencia de las drogas, medicamentos o alcohol.

⚠ DANGER**Siempre se debe usar vestimenta adecuada.**

Nunca use ropa suelta o las joyas que puedan quedar atrapados en las piezas móviles. Puestas unas chanclas de goma está recomendado para las mejores condiciones.

⚠ DANGER**Siempre utilice gafas de seguridad y Use protección para los oídos.**

También usa una cara o mascarilla si la operación de corte es polvoriento.

⚠ DANGER**Nunca Excederse.**

Mantenga su calzado apropiado y en equilibrio en todo momento.

⚠ DANGER**Nunca se pare sobre herramientas.**

Lesiones graves pueden ocurrir si la herramienta se inclina o si la herramienta cortante es accidentalmente contactados.

⚠ DANGER**Siempre desconecte Herramientas.**

Desconecte herramientas antes del servicio y al cambiar los accesorios como las cuchillas, brocas y cuchillas.

Evitar siempre ausencias Accidentales.

Asegúrese de interruptor se encuentra en la posición OFF antes de enchufar en cable.

Nunca deje Desatendida ejecutar Herramientas.**⚠ DANGER****Siempre revise las partes dañadas.**

Antes de la primera o la continua utilización de la herramienta, un guardia o en alguna otra parte que está dañada debe verificarse para asegurar que funcione correctamente y realizar su función prevista. Revise la alineación de los elementos móviles, obligatorio de piezas móviles, rotura de las partes, el montaje, así como cualesquiera otras condiciones que puedan afectar a su funcionamiento. Un guardia u otras partes dañadas debe inmediatamente ser correctamente reparado o sustituido.

NORMAS ESPECIALES EN MATERIA DE SEGURIDAD DE SIERRAS

1. Siempre se detienen las sierras de cinta antes de quitar chatarra piezas de la tabla.
2. Siempre mantenga las manos y los dedos lejos de la cuchilla.
3. Nunca había intentado stock que no tienen una superficie plana, a menos que un soporte adecuado es utilizada.
4. Siempre mantenga material con firmeza y alimentarla en la cuchilla a un ritmo moderado.
5. Siempre apague la máquina si el material se ha retirado de la instalación incompleta.
6. Verifique las pala tamaño y tipo de espesor y el tipo de material cortado.
7. Asegúrese de que la tensión de la hoja y la cuchilla de seguimiento están correctamente ajustado.
8. Hacer "alivio" cortes antes de cortar largas curvas.
9. Liberar la tensión de la hoja cuando vio no será utilizado por un largo período de tiempo.
10. Nota y siga las instrucciones y advertencias de seguridad que aparecen en la parte baja puerta de esta sierra.



ESPECIFICACIONES

Longitud de la Hoja.....	99-3/4"	Tamaño de la Tabla.....	15-3/4" x 20-3/8"
Ancho de la Hoja.....	1/4" to 3/4"	La Tabla Basculante.....	0-45 Degrees
Ancho de la Garganta.....	13-1/2"	Motor.....	1 HP
Profundidad de Corte.....	8"	Tension del Motor.....	120/240
Las Velocidades de la Hoja.....	1620/3340 ft/min	Amperaje del Motor.....	9/4.5 A
Puertos de Polvo.....	2-1/2" and 4"	Peso.....	160 LBS

GUARDAR estas instrucciones.
Referirse a ellos con frecuencia.

ASAMBLEA

1. HERRAMIENTAS NECESARIAS PARA EL MONTAJE

Artículo	Descripción	Cantidad
	Destornillador Phillips.....	1
	Llave ajustable.....	1
	en ángulo recto.....	1

2. DESEMBALAJE y comprobación CONTENIDO

Modelo 10-321 14" Sierra de cinta se envía completa en una sola caja.

A. Todas las partes separadas del cartón y compruebe cada tema con los envases de cartón contenidos lista a continuación para asegurarse de que todos los temas se contabilizan, antes de desechar cualquier material de empaque.























B. Retire la cubierta protectora del petróleo que se aplican a la tabla. Cualquier uso doméstico corriente tipo grasa y spot remove.

C. Aplique una capa de cera para la tabla y evitar la herrumbre. Limpie todas las partes cuidadosamente con un paño seco y limpio.

EL CARTÓN CONTENIDO

Tema	Número	Descripción	Cantidad
A		Cuerpo de La Máquina con la cuchilla instalado.....	1
B		Tabla.....	1
C		Paquete que contiene Abrir Stand	1
D		Bolsa de piezas sueltas.....	1
E		Tabla Superior charnela Asamblea.....	1
F		Manual del Operador.....	1

LISTA DE PARTES SUELTAS en bolsa

Artículo	Descripción	Cantidad
	2-1/ 2" puerto de Polvo.....	1
	Cabeza hexagonal tapa rosca M6x12.....	2
	Arandela 6.....	2
	Tensión de la Hoja mando.....	1
	Manivela.....	1
	Tuerca Hexagonal M6.....	2
	Tornillo Hexagonal M8x35.....	1
	Tuerca Hexagonal M8.....	1
	Tuerca M6.....	1
	Tubo.....	1
	Arandela 6.....	1
	Cabeza hexagonal tapa rosca M6x45.....	1
	Herramienta titular.....	1
	Tornillo Pan M5x10.....	2
	M2.5 hexagonal "L" torcer.....	1
	M3 hexagonal "L" torcer.....	1
	M4 hexagonal "L" torcer.....	1
	M5 hexagonal "L" torcer.....	1
	Hex Bolt, washer, nut assembly M8.....	24
	Hex Bolt, washer, nut assembly M6.....	4
	Rubber foot.....	4
	Tornillo Hexagonal M8x16.....	4
	Arandela de cierre 8.....	4



A

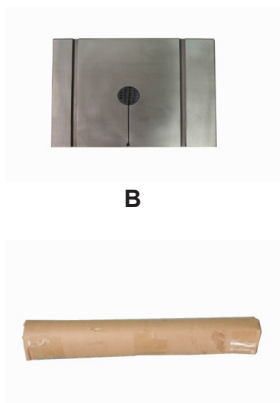

B



D



E



F



G

3. ASAMBLEA INICIAL

La banda 10-321 se vio facilitada parcialmente montado. Antes de su utilización, los siguientes elementos han de ser montados: Abrir, 2-1/ 2" Puerto de polvo, Tabla, tensión de la Hoja Mando, porta herramientas, y Manivela.

ADVERTENCIA: Para evitar lesiones, no intente ejecutar o utilizar esta máquina hasta que todos se arman y funciona correctamente.

A. Montaje del soporte Abierto

-Compruebe contenido contra la lista de piezas.

Sugerencia: Todos los paneles frontal y lateral montar detrás (interior) pierna piezas.

- Sujetar en el panel frontal para emparejar las piernas, utilizando hex transporte los pernos, arandelas y tuercas hexagonales. No apriete.
- Sujetar panel lateral sobre al panel frontal y emparejados utilizando las piernas restantes hex transporte los pernos, arandelas y tuercas hexagonales.
- Sujetar la parte frontal y lateral de vigas el emparejado patas con hex transporte los pernos, arandelas y tuercas hexagonales.
- Situado en una posición erguida, asegurando que los agujeros en el borde superior de la línea de paneles lo suficiente como para permitir tornillos de cabeza hexagonal para pasar a través. Apriete las tuercas hexagonales transporte pernos y tuercas hexagonales.
- Presione patas de goma en el extremo de patas del estante.
- Con la ayuda de un asistente, levantar banda vio y colocar cuidadosamente en su lugar en la parte superior del soporte.
- Instalar el sistema base de soporte con tornillo cabeza hexagonal (11) y la arandela (10) a través de stand y base de la sierra, a continuación, lavadora (10) y tuerca hexagonal (9) en la parte superior de base de la sierra. Repita el procedimiento en los cuatro ángulos antes de apretar plenamente.

Lista de piezas

Tema Número	Descripción	Cantidad
1	Haz Frente	2
2	Haz Lado	2
3	Pierna	4
4	Panel Lateral	2
5	Panel frontal	2
6	Tuerca Hexagonal	24
7	Arandela	24
8	Transporte tornillo hexagonal	24
9	Tuerca Hexagonal	8
10	Arandela	8
11	Tornillo cabeza hexagonal	4
12	Pies de Goma	4
13	Arandela	4

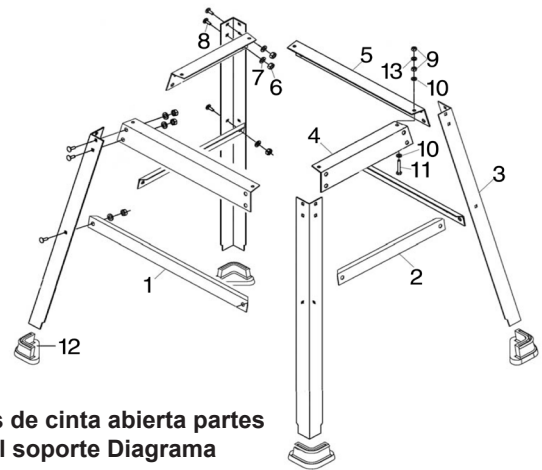

Sierras de cinta abierta partes del soporte Diagrama

B. Ensamblar los 2-1/ 2" puerto de polvo a la sierra de cinta encuadrar con cabeza hexagonal tapa rosca y lavadora. Coloque el 2-1/ 2" puerto de polvo a un lado de la sierra de cinta. Busque dos hexagonal tornillos y dos arandelas de la bolsa de piezas sueltas. Montar el puerto de polvo de las sierras de cinta calendario e instalar una cabeza hexagonal tapa rosca con lavadora en cada hoyo, luego apriete con M5 Hex "L" inglesa. (Véase la figura 1)

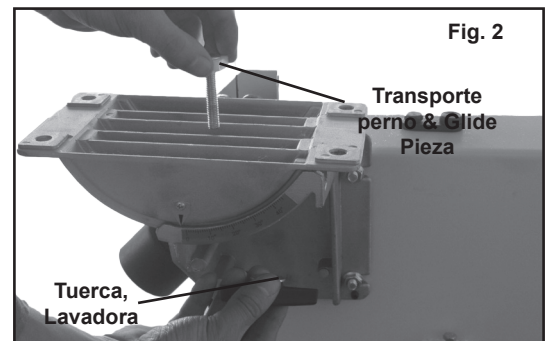
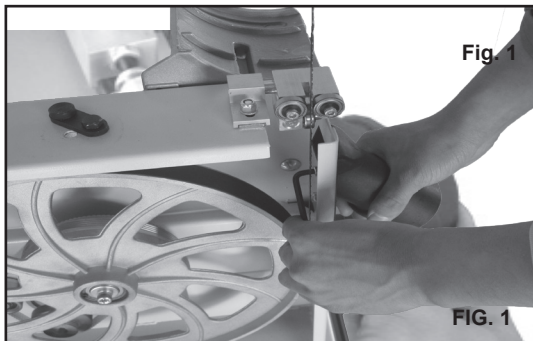

D. Coloque la tabla en la tabla superior charnela. Cuidadosamente alimentar la cuchilla a través de la ranura de la tabla. (Véase la figura 2A)

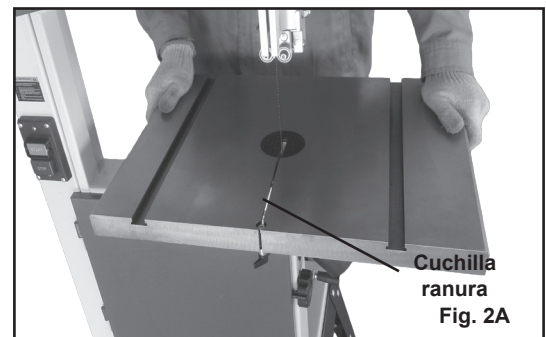

C. Montar la parte superior de la tabla charnela inferior tabla charnela con transporte perno, Glide pieza, lavadora y tuerca (ver fig. 2).

E. Busque cuatro pernos hexagonales y cuatro arandelas de la bolsa de piezas sueltas usada para montar el cuadro. Montar la tabla en la tabla superior charnela e instalar un perno con lavadora en cada hoyo, luego apriete con una llave hexagonal 13mm. (Véase la figura. 3)

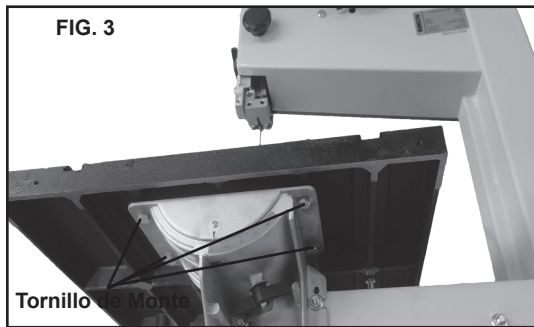

F. Siguiendo localizar un tornillo hexagonal M8x45 y una tuerca hexagonal M8. Instalar por debajo de la mesa como se muestra. Esta asamblea se utiliza para nivelar la mesa. (Véase la figura. 4)

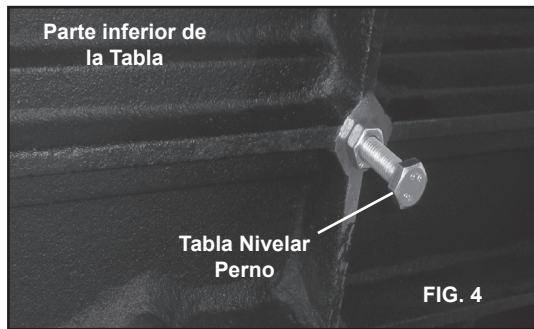

G. Utilice la cabeza hexagonal tapa rosca, lavadora, buje y tuerca para corregir la mesa de trabajo planitud. (Ver Fig. 5)

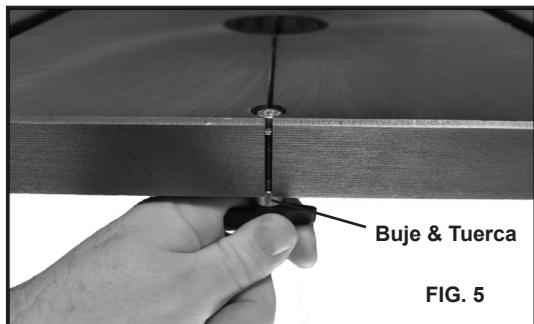

H. Atribuímos la manivela de la tensión de la correa brazo articulado con el M6 tuerca hexagonal. (Véase la figura. 6)



I. Ensamblar la herramienta titular a la columna de la sierra de cinta con dos tornillos de cabeza pan. Busque dos tornillos pan de la bolsa de piezas sueltas. Monte la herramienta titular a la columna e instalar un tornillo pan en cada hoyo, luego apriete con destornillador Phillips. (Véase la figura. 7)

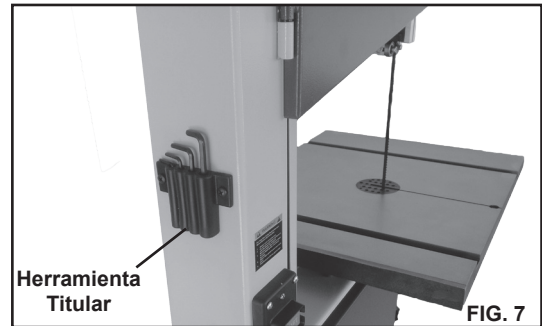

J. Siguiendo localizar un tornillo hexagonal M8x45 y una tuerca hexagonal M8. Instalar por debajo de la mesa Coloque la tensión de la hoja mando a la tensión de la hoja asamblea. (Véase la figura. 8)



K. Ésta tiene un 2-1/2" puerto de polvo y 4" puerto de polvo incluido para la conexión de ancho estándar tienda tubos de vacío. (Véase la figura. 9) Se recomienda que cuando se está en uso, la sierra de cinta está conectado a un colector de polvo.

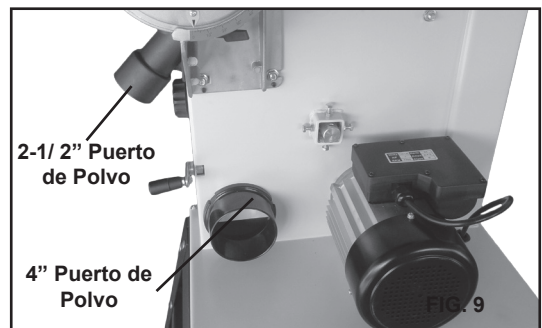

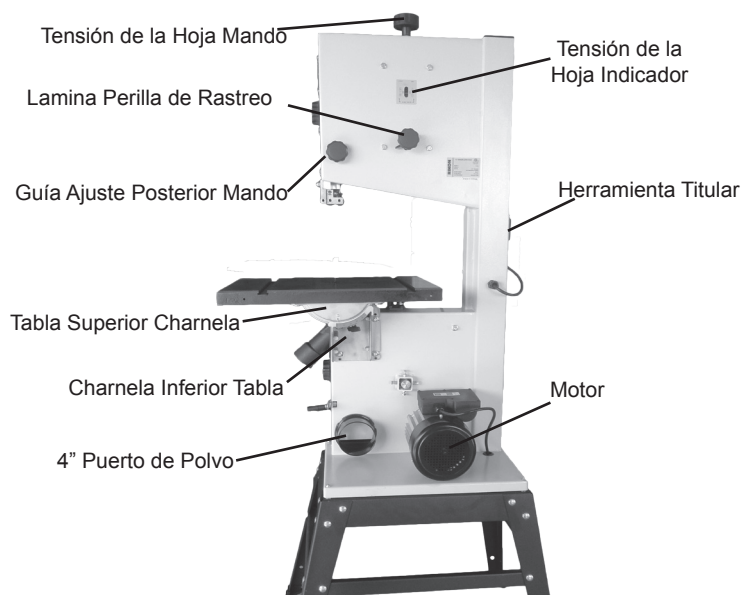

AJUSTE

1. Centrar LA TABLA

A. Afloje los cuatro pernos hexagonales montar la tabla para la tabla superior charnela. (Véase la figura 10)

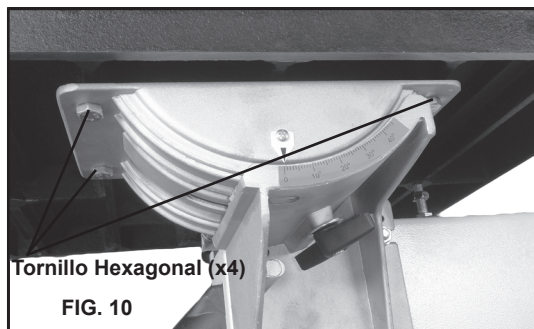

B. Mueva el cuadro lateralmente como sea necesario, hasta que la cuchilla pasa por el centro de inserción de la mesa.

C. Si la adaptación de "B" no es suficiente para centrar la mesa, afloje los cuatro las tuercas para sujetar la brida inferior tabla charnela y moverla hacia los lados para colocar la tabla en el centro.

D. Vuelva a apretar los tornillos hexagonales de charnela; verifique nuevamente la cuchilla posición.

2. LA MESA cuadrada con CUCHILLA en posición derecha e izquierda

Afloje la tuerca en la parte inferior tabla charnela y colocar un plaza tamaño adecuado contra la cuchilla en posición derecha e izquierda. Si la tabla requiere ajuste, proceda de la siguiente manera:

A. Usando una llave de tuercas, suelte la tuerca hexagonal por debajo de la mesa. (Véase la figura 11)

B. Coloque la llave de tuercas hexagonales en el perno y ajustar hasta la mesa es cuadrada con la cuchilla. (Véase la figura 11)

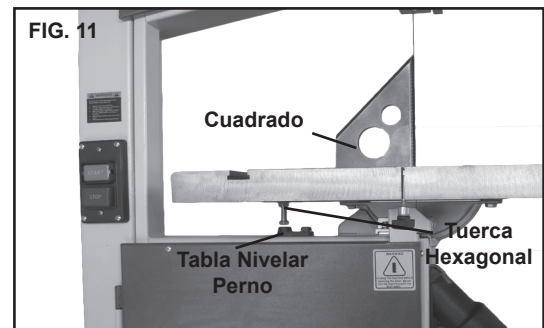

C. Apriete la tuerca hexagonal y compruebe la cuchilla y la tabla de plaza.

D. Bloquear la tabla en su lugar y asegúrese de que el indicador lee cero grados en el lado inferior del cuadro charnela. Afloje el tornillo que asegura el indicador y recuperar si es necesario dar lectura cero grado. (Véase la figura 12)

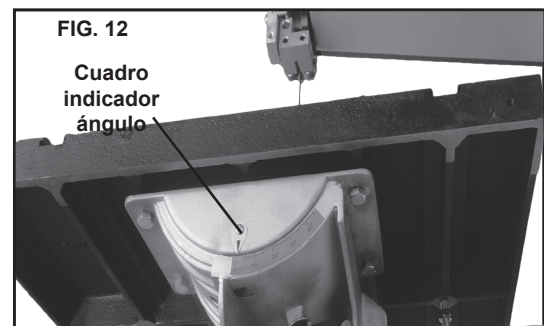

3. LA MESA CUADRADA DE VUELTA DE HOJA

Colocar un cuadrado en la parte trasera (no-diente) lado de la cuchilla. Si encuentra que el cuadro va cuesta arriba o cuesta abajo, usted le da de comer la pieza de trabajo, proceda de la siguiente manera:

- Usando una llave de tuercas, suelte la brida tuerca en la parte inferior tabla charnela. (Véase la figura 13)
- Coloque el M5 Hex "L" llave hexagonal en el tornillo de ajuste y ajustar hasta la mesa es cuadrada con la cuchilla en la parte trasera (no-diente) lado de la cuchilla.

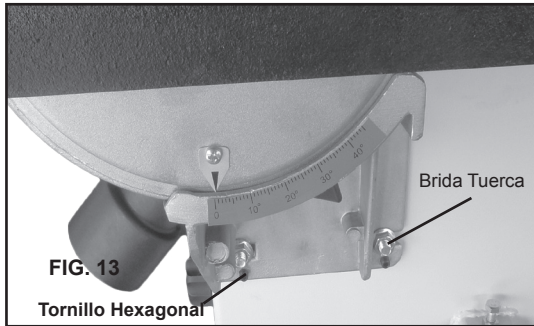

- Apriete la tuerca de brida y vuelva a comprobar la cuchilla y la tabla de plaza.

4. LA TABLA BASCULANTE

Bisel de cortes, la tabla se inclina hacia 0 hasta los 45 grados.

- Para inclinar la mesa, afloje la tuerca de la tabla charnela, puso la mesa al ángulo requerido y apriete la tuerca de nuevo (véase la figura 14).

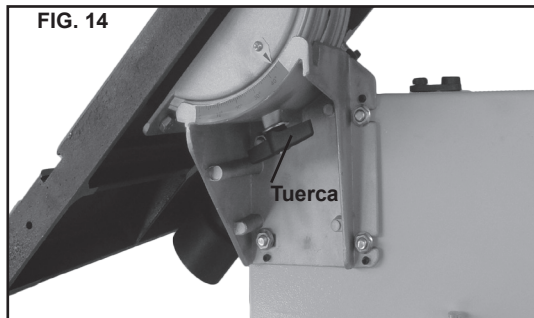

- Es recomendado para verificar el correcto ajuste del ángulo utilizando un ángulo guía, o haciendo que los cortes de prueba en madera de desecho. Ajuste el indicador en consecuencia mediante el uso de un destornillador Phillips.

5. AJUSTAR LA TENSIÓN DE LA HOJA

Para aflojar la tensión de la cuchilla, gire la perilla tensión de la hoja del reloj y la tensión indicador bajará. Para ajustar la tensión de la cuchilla, gire la tensión perilla a la derecha, y indicador la tensión aumentará. (Véase la figura 15)

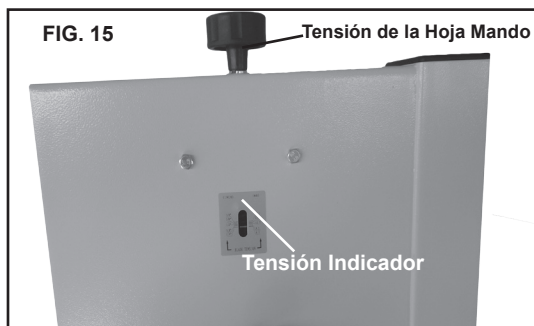

6. MODIFICAR y ADECUAR LA CUCHILLA

Esta banda se vio de fábrica equipada con un propósito general cuchilla para cortar madera, la cuchilla está establecido antes de la entrega. Para cambiar la hoja de la sierra; el siguiente procedimiento debe seguirse:

ADVERTENCIA: Para evitar daños en caso de partida inesperada, cada vez que cambia la cuchilla o llevar a cabo ajustes, cambie la banda vio apagado y desconecte el cable de alimentación de la toma de corriente. Para evitar lesiones en las manos para la manipulación de la cuchilla de la sierra, use guantes cuando sea necesario.

- Abra la puerta superior e inferior de los mandos del bloqueo de la puerta.
- Aflojar la tensión de la hoja por convertir a la tensión de la hoja situado en la parte superior de la rueda superior izquierda hasta vivienda la cuchilla ha disminuido(vista desde arriba)(véase la figura 16).
- Retire la cuchilla de la parte superior e inferior ruedas.
- Cuando se instala la cuchilla garantizar los dientes de la cuchilla están apuntando hacia abajo y hacia usted en la posición donde la cuchilla pasa a través de la tabla.



- Ténselo de la nueva hoja de la sierra y comprobar el seguimiento de cuchilla girando la rueda superior a mano. La cuchilla debe ejecutar en el centro de la banda vio las ruedas.
- Si es necesario ajustar el seguimiento de la cuchilla; proceder como se menciona más abajo "SEGUIMIENTO DE LA HOJA DE LA SIERRA"
- Cerrar la parte superior e inferior puertas girando el bloqueo de la puerta mandos antes de volver a conectar la fuente de alimentación.

7. SEGUIMIENTO DE LA HOJA DE LA SIERRA

Ajustar el seguimiento de la cuchilla antes de establecer la cuchilla guías. Una vez que la cuchilla esté instalado y tensados, vía la cuchilla ajustando el potenciómetro de rastreo a mano (ver fig. 17). La cuchilla debe ejecutar en el centro de la banda vio las ruedas. Utilice la ventana hoja de seguimiento para comprobar la posición de rueda. Cuando el ajuste correcto se logra bloquear el rastreo de mando con la tuerca.

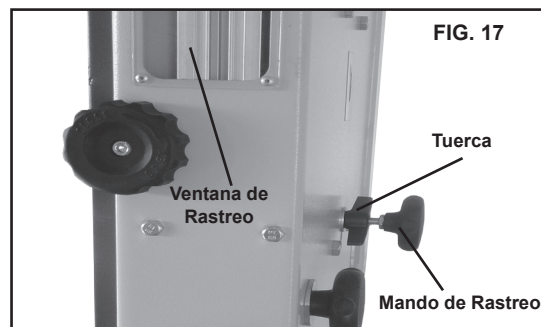

8. AJUSTE DE LA altura de corte

- A. La hoya superior guía debería establecerse lo más próxima posible en la pieza de trabajo.
- B. Para ajustar la altura, afloje la tuerca a un lado de la rueda superior la vivienda. (Ver Fig. 18)
- C. Ajuste la cuchilla guía a la altura requerida girando el mando guía ajuste posterior.
- D. Apriete la tuerca de ajuste altura correcta.

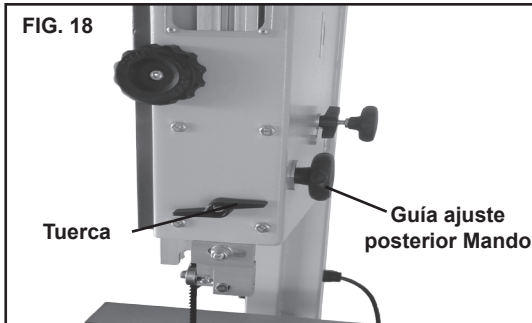

11. AJUSTE LA CUCHILLA guías

La Hoya Superior Guía

- A. Para ajustar la hoya superior guías, primera posición derecha e izquierda de rodillos guía relativa a la cuchilla aflojando la tuerca de bloqueo (FIG. 19) Y moviendo la guía transportista hasta tanto roller guías son aproximadamente 1/16" detrás de las gargantas de la cuchilla.
- B. Ajuste ambos guías de rodillos para dentro de 1/32" de la cuchilla por liberar la guía el tornillo de ajuste (FIG. 19) De cada lado de la cuchilla y mover las guías hasta la posición deseada. Bloquear el rodillo guía en posición con el tornillo de ajuste manual. No establezca el rodillo guías demasiado cerca ya que esto afectaría adversamente la vida de la cuchilla.

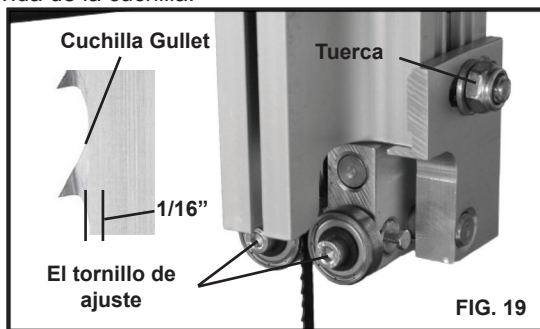

- C. Ajustar el rodillo trasero de ser una guía clara de la parte posterior de la cuchilla al liberar el tornillo de ajuste manual FIG. 20 Y moviendo la guía de aproximadamente 1/32" detrás de la cuchilla.
- D. Cuando el ajuste correcto es alcanzado, bloquear el rodillo guía en posición con la guía tornillo de ajuste FIG. 20.



La hoya inferior Guía

- A. Para ajustar la hoya inferior guías, primera posición derecha e izquierda de rodillos guía relativa a la cuchilla aflojando la tuerca de bloqueo (FIG. 21) Y moviendo la guía transportista hasta tanto roller guías son aproximadamente 1/16" detrás de las goletas (véase el recuadro, FIG. 19) De la cuchilla.
- B. Ajuste ambos guías de rodillos para dentro de 1/32" de la cuchilla por liberar la guía el tornillo de ajuste (FIG. 21) Y moviendo la guía hasta la posición deseada. Bloquear el rodillo guía en posición con el tornillo de ajuste manual. No establezca el rodillo guías demasiado cerca ya que esto afectaría adversamente la vida de la cuchilla.
- C. Ajustar el rodillo trasero de ser una guía clara de la parte posterior de la cuchilla por liberar el guía el tornillo de ajuste (FIG. 21) Y moviendo la guía de aproximadamente 1/32" detrás de la cuchilla.

- D. Cuando el ajuste correcto es alcanzado, bloquear el rodillo guías en posición con la guía tornillos de ajuste.

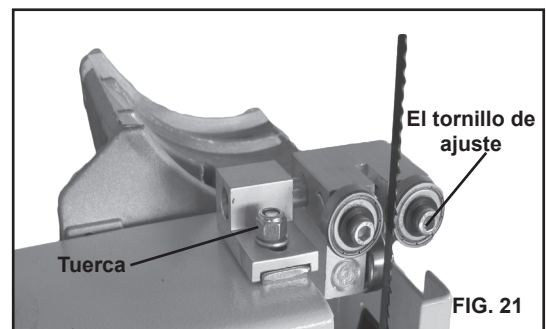

12. CAMBIO DE LA CUCHILLA VELOCIDAD

ADVERTENCIA: Antes de cambiar la velocidad asegúrese siempre de que la máquina se ha desconectado del suministro eléctrico.

Esta banda ha visto dos omóplato velocidades:

- A. 1620 Pies/min de maderas duras, algunos plásticos y algunos metales no ferrosos.
 - B. 3341 Pies/min para todas las demás madera.
- La menor bandwheel tiene dos, integral, multi-vee forma poleas y el eje del motor tiene una doble multi-vee forma polea.

La correa bandwheel pasa alrededor de la polea, la polea del motor y la tensión rueda. La tensión de la correa es liberado y se aplicará mediante la manivela (ver fig. 22). Esta se mueve la rueda tensión y permite la velocidad que se va a cambiar. (Véase LA CORREA posiciones alta/baja velocidad)

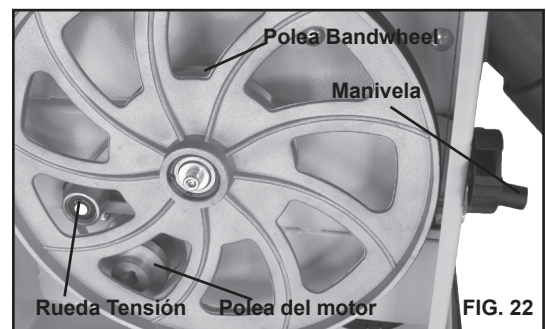

13. CORREA posiciones alta/baja velocidad

A. La baja velocidad 1620 ft/min y colocar el cinturón de la polea frontal tanto en el motor y bandwheel. (Ver Fig. 23)

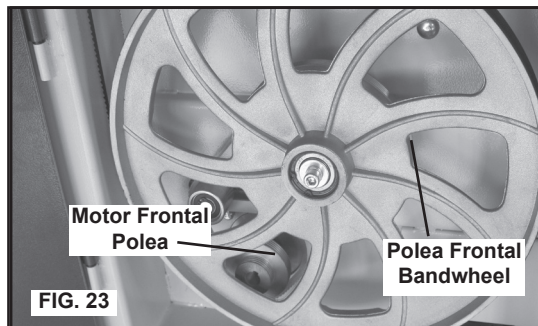

B. Para la alta velocidad 3341 ft/min, el uso del cinturón debería ser montados en la parte trasera polea tanto en el motor y bandwheel. (Ver Fig. 24) Nota: La parte trasera bandwheel polea se oculta.

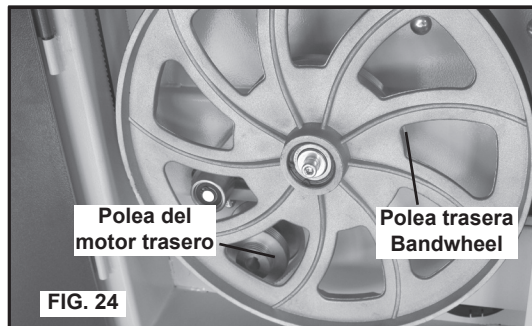

14. CAMBIAR LA CORREA

A. Suelte la cuchilla tensión apagando la tensión de la hoja situado en la parte superior de la banda vio las manecillas del reloj.

B. Liberar la tensión de la correa utilizando la manivela.

C. Usando una llave hexagonal quitar la cabeza hexagonal tapa rosca (ver fig. 25) Desde el centro de la rueda inferior.

D. Deslice cuidadosamente la rueda inferior y, al mismo tiempo liberar la cuchilla de la rueda.

E. Quitar el casco antiguo de la correa y ajustarse a la nueva correa (garantizar las costillas en la correa de transmisión están colocados correctamente antes de volver a ensamblar y tensar la correa).

F. Siga los procedimientos para cambiar y ajustar la CUCHILLA Y SEGUIMIENTO LA HOJA DE LA SIERRA, antes de devolver el poder a la sierra de cinta y creación de empleo.



OPERACION

ADVERTENCIA: Antes de comenzar verifiquen si alguna parte de tu banda vio falta, mal funcionamiento, ha sido dañado o rota, como en el interruptor motor u otra operación, control, un dispositivo de seguridad o el cable de alimentación, apague la banda vio apagado y desconéctelo hasta la parte en concreto está correctamente reparado o sustituido.

La cuchilla corta en un continuo palotes. Para evitar lesiones cuando manos son inevitablemente cerca de la cuchilla de la Sierra, deben ser colocados a ambos lados de la pala (ver fig. 26), no está en línea con el mismo (ver fig. 27). Utilice un empuje stick siempre que sea posible cuando se trabaja en estrecha proximidad con la cuchilla.

Iniciar la banda vio presionando el botón verde (ver fig. 28) Y esperar la banda vio venir a toda velocidad antes de comenzar a cortar. Nunca iniciar el sierra de cinta con la pieza de trabajo en contacto con la cuchilla.

Comer lentamente la pieza de trabajo hacia la cuchilla de la Sierra, dejando sólo la luz presión sobre ella. Con ambas manos, con firmeza la pieza de trabajo hacia abajo sobre la mesa, y pienso que hacia la cuchilla con lentitud.

Una vez que la operación de corte es vuelta completa la banda cortar con el botón rojo DETENER paddle en el interruptor.

Para obtener los mejores resultados la cuchilla deben estar bien afilados. Seleccione el derecho cuchilla para el trabajo, dependiendo del grosor de la madera el corte. Los más delgados y más difícil la madera, el más fino los dientes (14 dientes por pulgada) de la cuchilla. Utilice una multa diente cuchilla para cortar curvas muy cerradas. Para cortar madera gruesa uso menos dientes, alrededor de 4 dientes por pulgada.

La máquina está especialmente capacitada para cortar las curvas, sino que también hará cortes rectos. No intente poner la pieza de trabajo sin que se pierda nada, ya que esto puede causar que la pieza de trabajo que se ha quedado atascado o la cuchilla de doblar.

Accesorio tope es utilizada para garantizar la seguridad y precisa cortes rectos de la pieza de trabajo, generalmente en la misma dirección que el grano de la madera. Por favor, consulte las instrucciones separadas en el paquete accesorio tope.

ADVERTENCIA: Si usted necesita cortar con el tope y una tabla inclinada, el tope debe estar instalado en el lado de la mesa que está curvada hacia abajo.

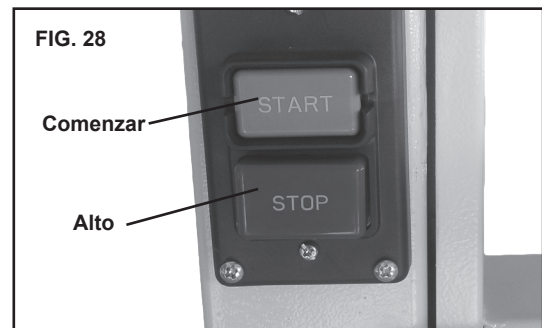
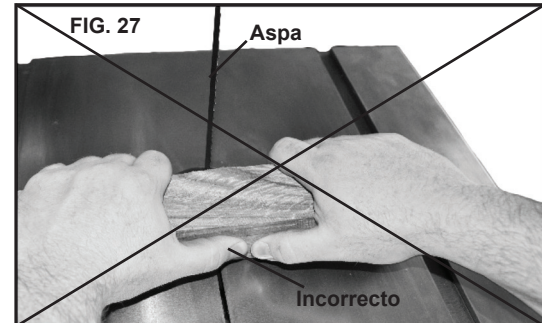
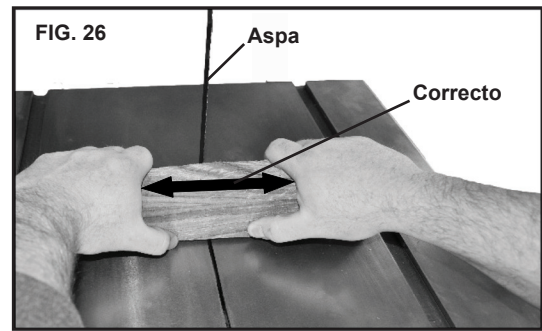

MANTENIMIENTO

ADVERTENCIA: Para evitar lesiones debido a las inesperadas empezando, antes de la limpieza o llevar a cabo trabajos de mantenimiento, apague y desconecte la sierra de cinta de la fuente de energía.

Nunca utilice agua u otros líquidos para limpiar la sierra de cinta. Utilizar un pincel seco.

Mantenimiento regular de las sierras de cinta para evitar problemas innecesarios.

A. Mantener la mesa limpia para asegurar el correcto cortar.

B. Mantenga la parte exterior de la máquina limpia para asegurar el correcto funcionamiento de todas las piezas móviles y prevenir el desgaste excesivo.

C. Mantener las ranuras de ventilación del motor limpio para evitar que se sobrecaliente.

D. Mantener el interior (cerca de la cuchilla de la Sierra, etc.) limpia para evitar la acumulación de polvo (Véase fig. 29 & 30). Utilice captación de polvo si es posible.

E. Para prolongar la vida de la cuchilla, cuando ésta no está en uso por períodos prolongados, el despacho de la cuchilla tensión. Antes de volver a utilizar la banda vio asegúrese de que la cuchilla es re-tensada y seguimiento está activada.

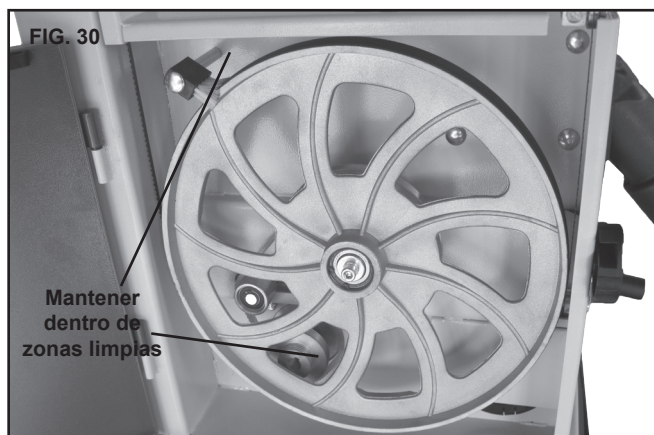
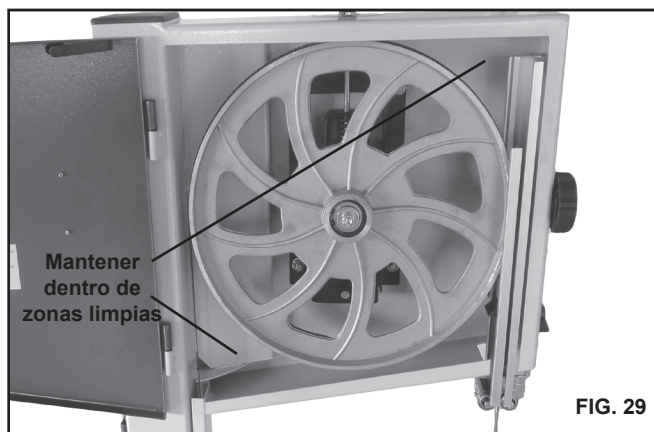

ESQUEMA ELÉCTRICO

ADVERTENCIA: Esta máquina debe estar fundamentada. Con el fin de evitar electrocuciones o fuego, toda reparación de sistema eléctrico sólo debe hacerse por un electricista calificado, utilizando una verdadera pieza de recambio.

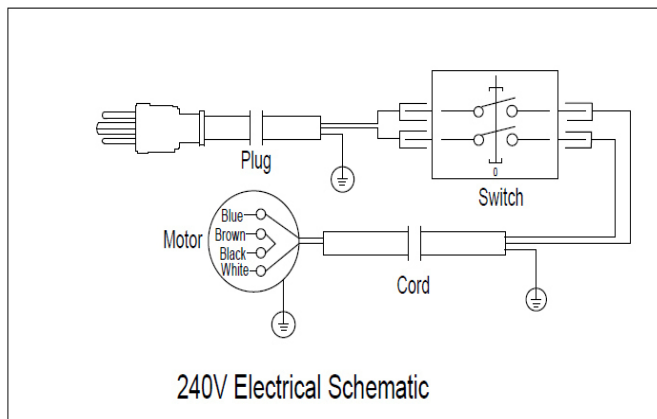
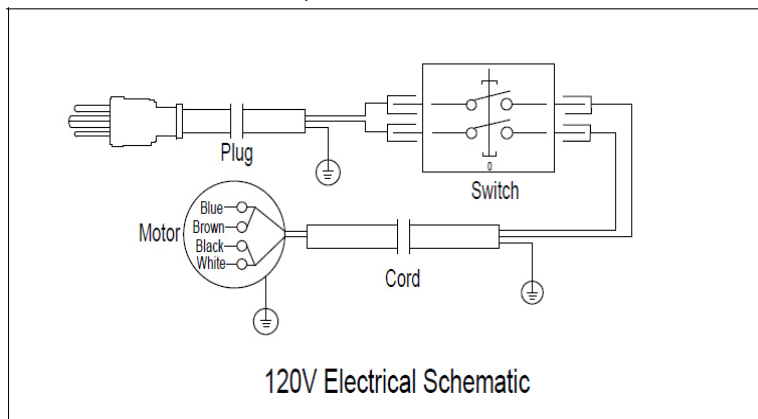

SOLUCIONAR PROBLEMAS

Problema	Diagnóstico	Remedio
La máquina no funciona cuando son activados.	<ol style="list-style-type: none"> 1. Ninguna fuente de alimentación. 2. Interruptor Defectuoso. 3. Motor Defectuoso. 	<ol style="list-style-type: none"> 1. Compruebe el cable de rotura. 2. Reemplazar el interruptor de bloqueo. 3. Motor Defectuoso.
La cuchilla no se mueve con el motor en marcha.	<ol style="list-style-type: none"> 1. La tensión de la hoja mando no se ha endurecido. 2. La cuchilla se salió una de las ruedas. 3. La cuchilla ha roto. 4. La correa ha encajado. 	<ol style="list-style-type: none"> 1. Apague el motor, apriete el botón de tensión cuchilla. 2. Abrir puertas y salir. 3. Reemplace la cuchilla. 4. Reemplazar el cinturón.
La cuchilla no cortar en línea recta.	<ol style="list-style-type: none"> 1. Tope para cortar no utilizados. 2. Velocidad de alimentación demasiado rápido. 3. Los dientes de la cuchilla son aburridos o dañado. 4. Guías cuchilla no convenientemente ajustada. 	<ol style="list-style-type: none"> 1. Utilice un tope. 2. Poner luz presión sobre la pieza de trabajo. Asegúrese de que la cuchilla no doblar. 3. Intente una nueva cuchilla. 4. Ajuste la cuchilla guías (ver instrucciones ajuste).
La cuchilla no cortar, o cortes muy lentamente.	<ol style="list-style-type: none"> 1. Los dientes son aburridos, causados por cortar materiales duros o utilización a largo plazo. 2. La hoja de la sierra se colocó al revés en la sierra de cinta. 	<ol style="list-style-type: none"> 1. Reemplace la cuchilla, utilice un 6 T. P. I. (Dientes por pulgada) cuchilla de la sierra para madera y materiales blandos. Utilice un 14 T. P. I. cuchilla materiales más arduamente. 2. Ajuste la cuchilla correctamente.
Aserrín se acumula dentro de la máquina.	Esto es normal	Limpie la máquina con regularidad. Abrir puertas y quitar el aserrín con una aspiradora.
Serrín dentro de la carcasa del motor.	Esto es normal	Limpie las ranuras de ventilación del motor con una aspiradora. De vez en cuando quitar el aserrín para evitar que se vieran arrastradas a la vivienda.
La máquina no puede cortar a una temperatura de 45 o 90 grados.	<ol style="list-style-type: none"> 1. El cuadro no está formando ángulos rectos con la cuchilla. 2. La cuchilla es aburrida o demasiado se ejercieron presiones sobre la pieza de trabajo. 	<ol style="list-style-type: none"> 1. Ajustar la tabla. 2. Reemplace la cuchilla o realizar menos presión sobre la pieza de trabajo.
La cuchilla no pueden ser debidamente ubicadas en las ruedas.	<ol style="list-style-type: none"> 1. Las ruedas no están armonizadas o defectuoso teniendo. 2. El rastreo de cuchilla mando no ha sido debidamente ajustado. 3. Less Than cuchilla. 	<ol style="list-style-type: none"> 1. Reemplazar teniendo. 2. Ajuste la cuchilla seguimiento de mando (vea AJUSTE instrucciones). 3. Reemplace la cuchilla.

PARTES DIAGRAMA 1

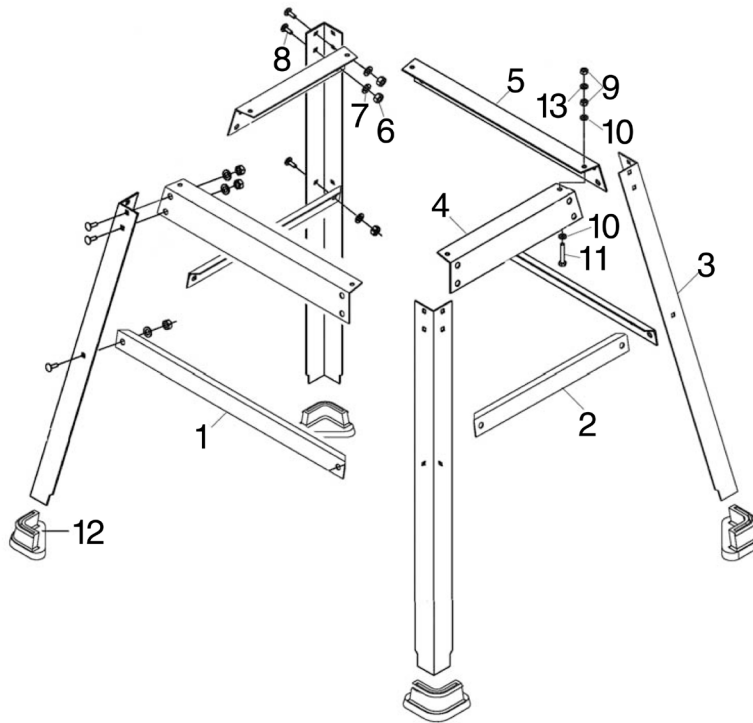

Listas de piezas 1

KEY NO.	MFG. PART NO.	DESCRIPCIÓN
1S	1-JL21050004-001Z	Haz Frente
2S	1-JL21050005-001Z	Haz Lado
3S	1-JL21050001-001Z	Pierna
4S	1-JL21050003-001Z	Panel Lateral
5S	1-JL21050002-001Z	Panel Frontal
6S	1-NUT5/16B	Tuerca Hexagonal
7S	1-WSH8GB97D1B	Arandela
8S	1-NEC5/16X5/8B	Tornillo Hexagonal
9S	1-NUT1/4B	Tuerca Hexagonal
10S	1-WSH6GB96B	Arandela
11S	1-HEX1/4X1 1/2B	Tornillo Hexagonal
12S	1-JL40060005	Calzado de Goma
13S	1-WSH6GB97D1B	Arandela de tipo resorte

PARTES DIAGRAMA 2

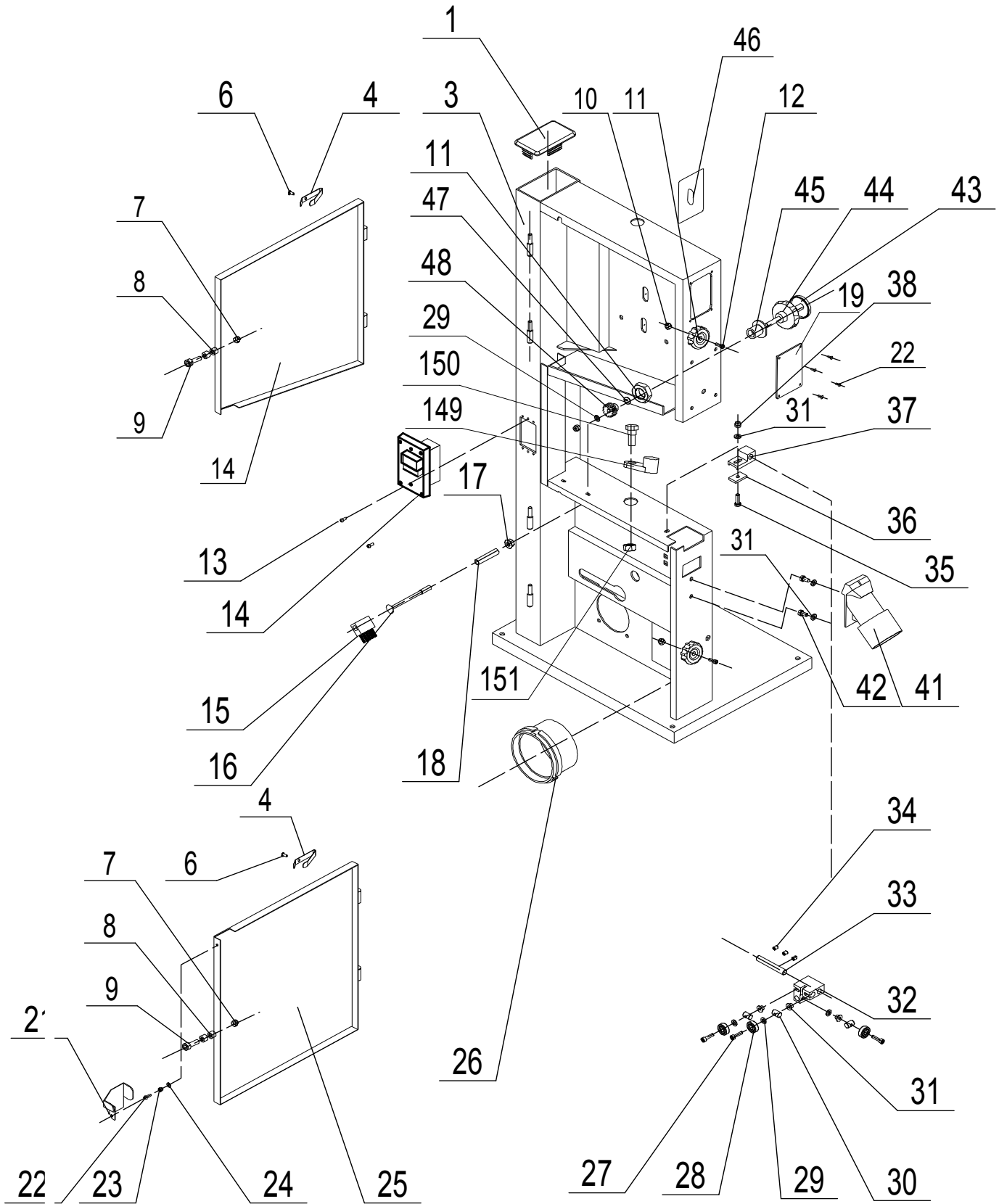

LISTA DE PIEZAS 2

KEY NO.	MFG. PART NO.	DESCRIPCIÓN
1	1-JL21010001A-001S	Comienzo plug
2	1-JL21011000R050W	Enmarcar
3	1-JL20010008	Hoja resorte
4	1-RVT4X8GB12618A	Remache
5	1-M6GB889Z	Tuerca M6
6	1-JL26010007	Buje
7	1-M6X25GB70Z	Tornillo hexagonal M6X25
8	1-M6GB889Z	Tuerca M6
9	1-JL26010006-001S	Bloqueo de la Puerta mando
10	1-M6X22GB70Z	Tornillo Hexagonal M6X25
11	1-M20GB6173Z	Tuerca Hexagonal M20
12	1-JL21012000J-049W	Puerta Superior
13	1-M4X20GB818Z	Tornillo Pan
14	1-HY56	Interruptor
15	1-JL20010004	Cepillo
16	1-M8X100GB14Z	Transporte perno M8X100
17	1-M8GB6177Z	Brida tuerca M8
18	1-JL20010003	Tubo
19	1-JL26010001	Ventana Transparente
20	1-RVT3X7GB12618A	Remache3x7
21	1-JL20010006-050W	Cuchilla Cubrir
22	1-M4X12GB818Z	Tornillo Pan
23	1-M4GB889Z	Tuerca M4
24	1-WSH4GB97D1Z	Arandela
25	1-JL21013000D-049W	Portezuela Inferior
26	1-JL20010007-001S	Puerto de Polvo
27	1-M5X20GB70Z	El tornillo de ajuste
28	1-BRG80018GB278	Soportar
29	1-WSH6GB97D1Z	Arandela 6
30	1-JL22042004	Teniendo monte cilindro
31	1-JL20042002	Teniendo buje
32	1-JL21042001	Guía Superior monte
33	1-JL22043002	Menor eje guía
34	1-M8X8GB80B	Tornillo Hexagonal M6x10
35	1-M6X20GB5783Z	Tornillo Hexagonal M6x20
36	1-JL20040001	Guía inferior monte asiento
37	1-JL21043001	Guía menor apoyo
38	1-M6GB889Z	Tuerca M6
39	1-JL21010019	Puerto de Polvo 2-1/2"
40	1-M6X12GB70D1Z	Tornillo Hexagonal
41	1-JL20024001-001S	Ajuste mando pac
42	1-JL20044001-001S	Ajuste mando cuerpo
43	1-JL20044002	Tubo
44	1-SR21020003	Regla
45	1-JL22040003	Arandela de tipo resorte
46	1-JL22040001	Engranar
149	1-JL21010014	Bloquear
150	1-JL26010015	Varilla Roscada
151	1-M8GB889Z	Tuerca

PARTES DIAGRAMA 3

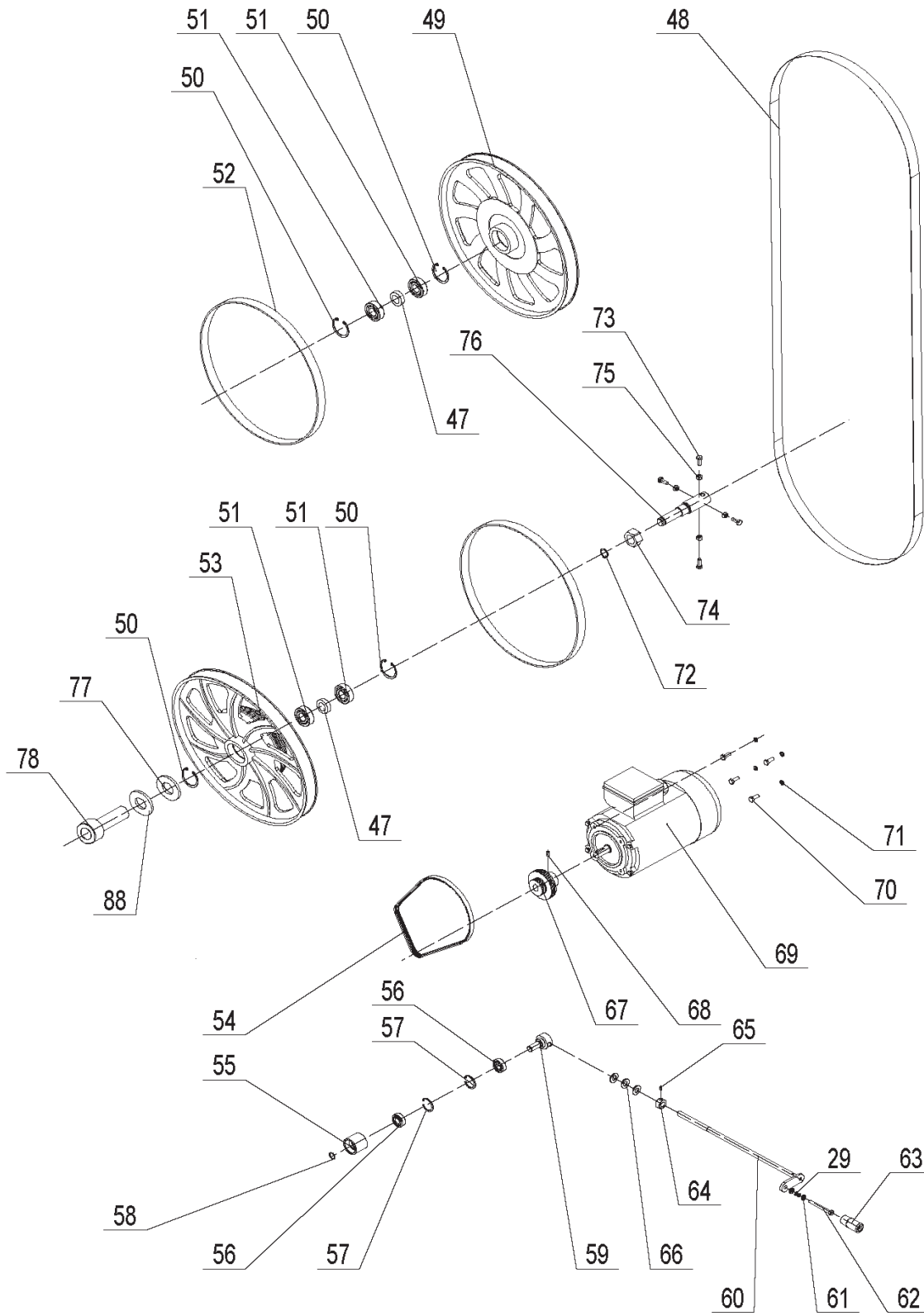

LISTA DE PIEZAS 3

KEY NO.	MFG. PART NO.	DESCRIPCIÓN
47	1-JL28020004	Buje
48	1-JL21020001K	Cuchilla
49	1-JL21022001A	Rueda Superior
50	1-CLP40GB893D1B	Anillo de retención 40
51	1-BRG6203-2Z-P5GB276	Sopotar
52	1-JL21022002A	Llanta
53	1-JL21023002C	Rueda Inferior
54	1-JL20020002	La correa
55	1-JL20014002A	Rueda Tensión
56	1-BRG6001-2RSGB276	Sopotar
57	1-CLP28GB893D1B	Anillo de retención 28
58	1-CLP12GB894D1B	Anillo de retención 12
59	1-JL20014001	Eje Móvil
60	1-JL21015100	Tensión de la correa brazo articulado
61	1-M6GB6172Z	Tuerca Hexagonal M6
62	1-M6X55GB65Z	Tornillo de ajuste M6X55
63	1-JL20015001-001S	Manivela
64	1-JL20010015	Correón
65	1-M5X8GB71Z	Tornillo de ajuste M5x8
66	1-WSH10GB97D1Z	Arandela 10
67	1-JL20070001	Polea del motor
68	1-M6X10GB80B	Tornillo Hexagonal M6x10
69	2-YYH806084	Motor
70	1-M6X16GB9074D15Z	Tornillo Hexagonal M6X16
71	1-WSH6GB93Z	Arandela de tipo resorte 6
72	1-CLP17GB894D1B	Anillo de retención 17
73	1-M6X20GB5783Z	Tornillo Hexagonal M6x20
74	1-JL20020004	Especial tuerca hexagonal
75	1-M6GB6170Z	Tornillo Hexagonal M6
76	1-JL21020002B	Baja teniendo perno
77	1-WSH8GB96Z	Arandela 8
78	1-M8X16GB70Z	Tornillo Hexagonal M8X16
88	1-WSH8GB93Z	Arandela de tipo resorte

PARTES DIAGRAMA 4

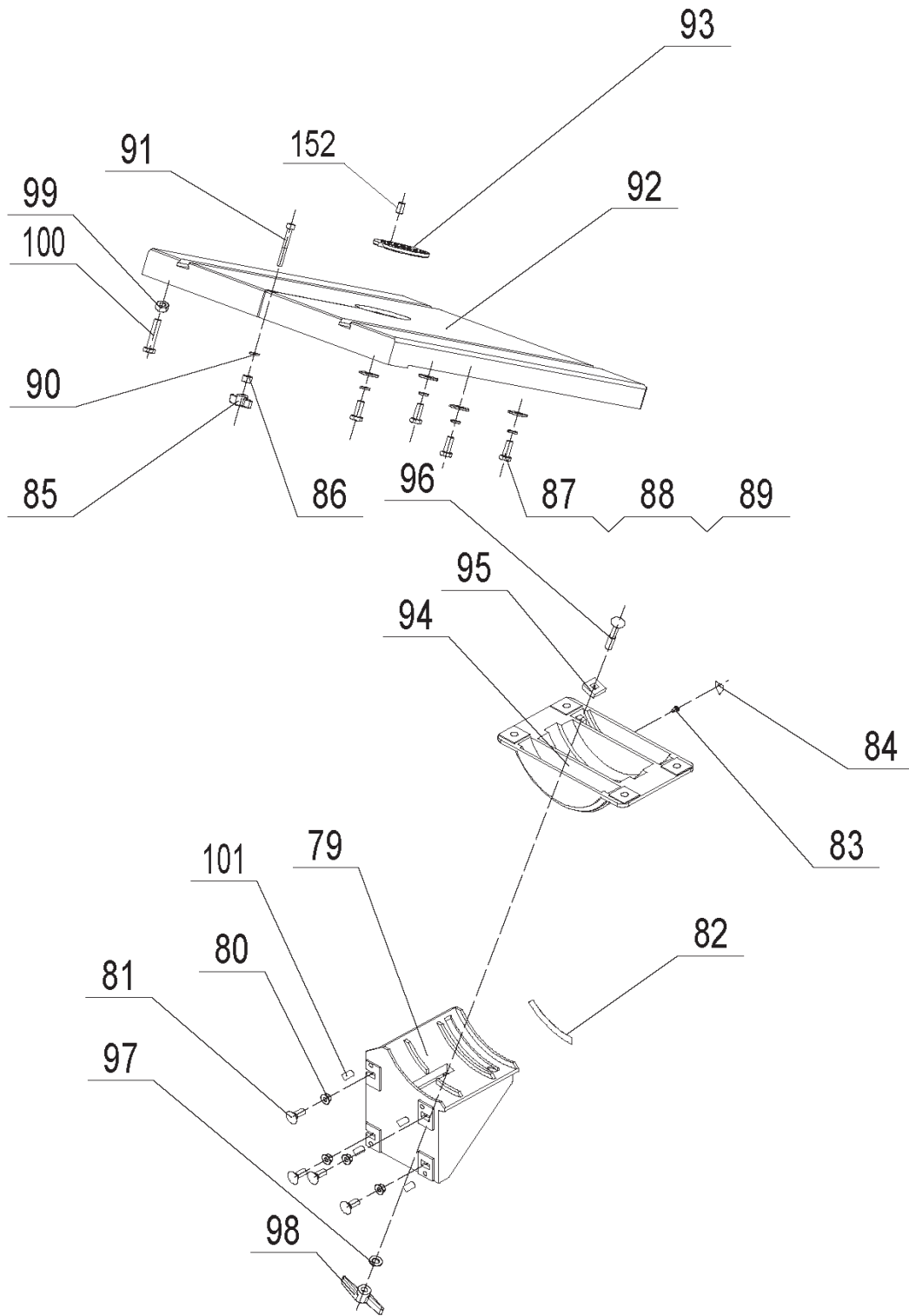

LISTA DE PIEZAS 4

KEY NO.	MFG. PART NO.	DESCRIPCIÓN
79	1-JL20030001A	CHARNELA inferior tabla
80	1-M8GB6177B	Brida tuerca M8
81	1-M8X20GB14Z	Transporte perno M8x20
82	1-JL20030004	Volviendo etiqueta
83	1-ST3D5X9D5GB845Z	Tornillos 3.5x9.5
84	1-1506003	Puntero
85	1-JL22020002-001S	Manija
86	1-JL21031003	Tubo
87	1-M8X20GB5783Z	Tornillo Hexagonal
88	1-WSH8GB93Z	Arandela de tipo resorte
89	1-WSH8GB96Z	Arandela
90	1-WSH6GB97D1Z	Arandela 6
91	1-M6X50GB70Z	Socket tornillo de cabeza
92	1-JL21031001D001G	Tabla
93	1-JL20031002C-001S	Insertar tabla
94	1-JL20032001	Tabla Superior charnela
95	1-WSH8GB96Z	Arandela 8
96	1-M8X50GB14Z	Transporte perno M8x50
97	1-WSH8GB97D1Z	Arandela 8
98	1-JL20010016-001S	Tuerca M8
99	1-M8GB6170Z	Nuez
100	1-M8X40GB5783Z	Perno
101	1-M6X10GB80B	Tornillo
152	1-M5X4GB80B	Tornillo

PARTES DIAGRAMA 5

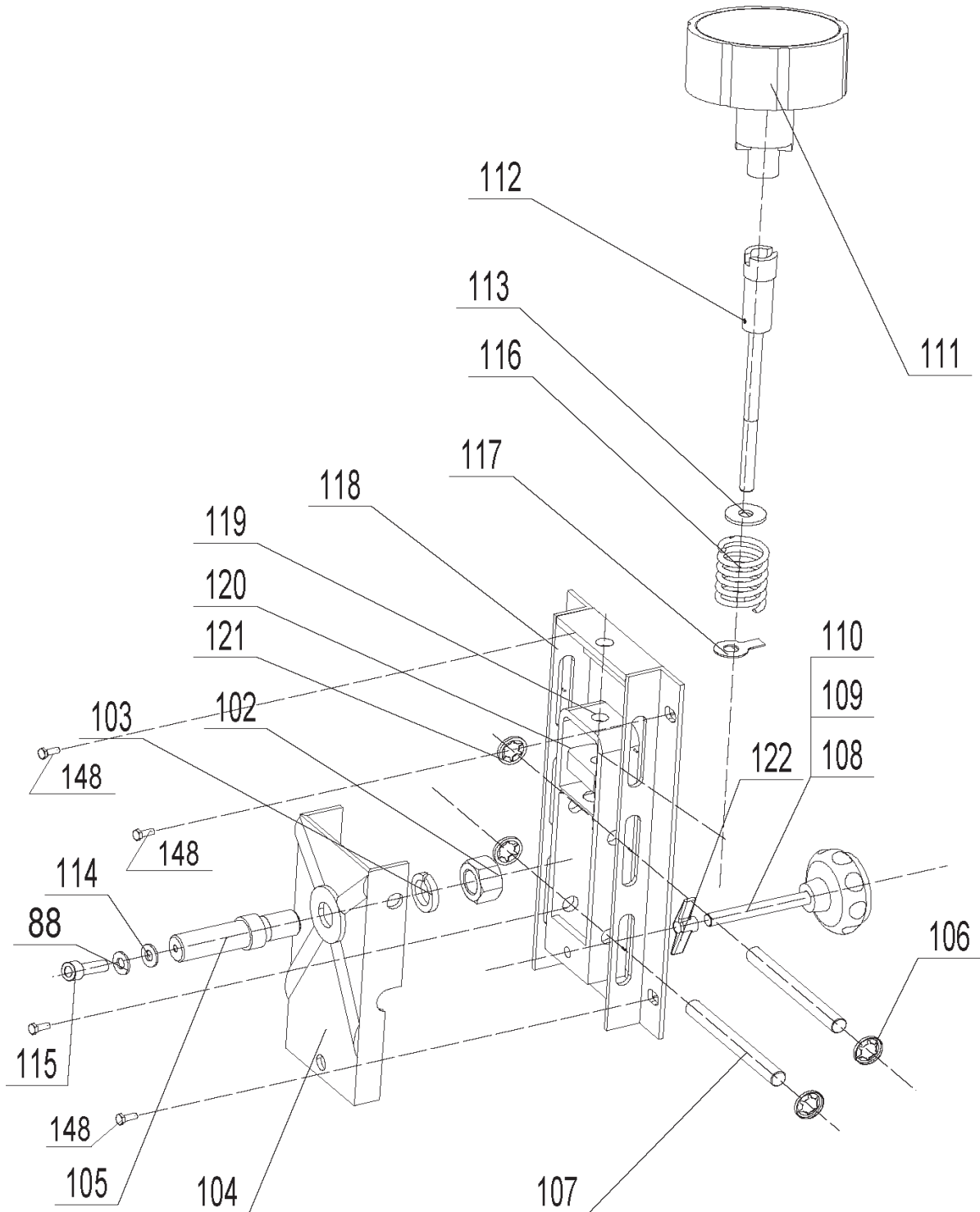

LISTA DE PIEZAS 5

KEY NO.	MFG. PART NO.	DESCRIPCIÓN
88	1-WSH8GB93Z	Arandela de tipo resorte
102	1-M16GB6171Z	Tuerca Hexagonal M16
103	1-WSH16GB93Z	Arandela de tipo resorte 16
104	1-JL20021005A001Z	Rueda carro
105	1-JL20021006D	Cojinete superior perno
106	1-JL20021004	Star cerradura
107	1-JL20021002	Montar el eje
108	1-JL20024001-001S	Ajuste mando pac
109	1-JL20024002-001S	Ajuste mando cuerpo
110	1-M8X70GB5781Z	Tornillo Hexagonal M8x70
111	1-JL21025000-001S	Tensión de la Hoja mando
112	1-JL21021200A	Cuchilla tensor
113	1-JL20030002	Glide pieza
114	1-WSH8GB96Z	Arandela 8
115	1-M8X16GB70Z	Tornillo Hexagonal M8X16
116	1-JL21021010A	Brotar
117	1-JL21020004-014T	Puntero
118	1-JL20021100A001Z	Tensión soporte
119	1-JL20021001B001Z	Cuchilla tensor
120	1-JL20021009	Tuerca de ajuste
121	1-JL20021004	Star cerradura
122	1-JL20010016-001S	Tuerca M8
148	1-M8X16GB5781Z	Perno hexagonal

PARTES DIAGRAMA 6

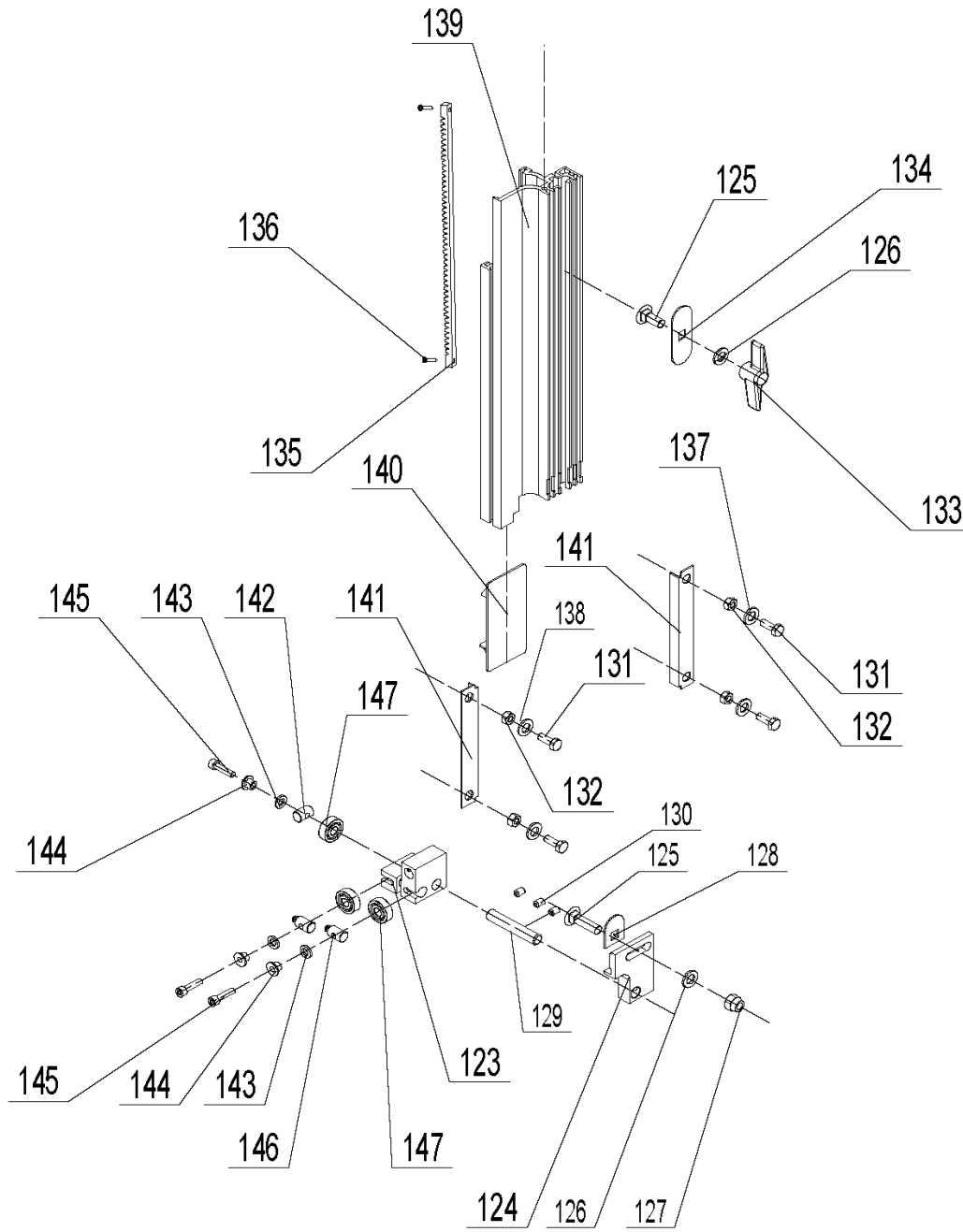

LISTA DE PIEZAS 6

KEY NO.	MFG. PART NO.	DESCRIPCIÓN
123	1-JL21042001	Guía Superior cuerpo
124	1-JL21042002	Guía Superior monte
125	1-LOC5/16Z	Transporte pernoM8x20
126	1-WSH8GB97D1Z	Arandela 8
127	1-NEC5/16X7/8	Tuerca Hexagonal
128	1-JL22041004	Limpiador Especial
129	1-JL22042002	Guía Superior eje
130	1-M6X10GB80B	Tornillo Hexagonal M6x10
131	1-M6X16GB5783B	Tornillo Hexagonal M6x16
132	1-M6GB6170Z	Tuerca Hexagonal M6
133	1-JL20010016-001S	Tuerca M8
134	1-JL20041004	Perno guía
135	1-JL20044003	Percha
136	1-ST3D5X13GB846Z	Tornillos ST3.5x13
137	1-WSH6GB862D2B	Arandela 6
138	1-WSH6GB862D2B	Arandela 6
139	1-JL21041001F	Cuchilla guía
140	1-JL21041002-001S	Control deslizante
141	1-JL20010005	Guía soporte
142	1-JL22042004	Micro-ajuste mando
143	1-WSH6GB97D1Z	Arandela 6
144	1-JL20042002	Buje
145	1-M5X20GB70Z	El tornillo de ajuste
146	1-JL22042003	Micro-ajuste mando
147	1-BRG80018GB278	Soportar

How-To's for all Band Saw Blades

Choosing the Correct Blade Width

Blade width is measured from the tips of the teeth to the back edge of the blade as shown above. The instructions for the particular machine being used should be followed when selecting blade width.



If no such instructions are provided, blade width should be determined with the following guidelines:

For Cut-Off Sawing, the blade should be as wide as the machine will allow. The wider the band is, the straighter the cut will be. Faster feeding can be achieved.

For Contour Sawing, the blade should be as wide as the machine allows, but still narrow enough so that it can cut the desired shape (radius). Minimum dimensions for different cutting radii are shown on the chart at right.

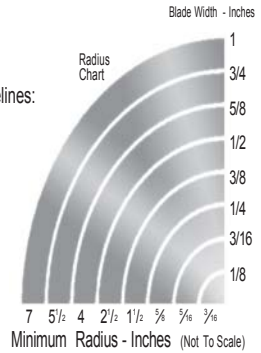

How To Choose The Correct Number Of Teeth Per Inch (TPI)

The number of teeth per inch (TPI) is important in obtaining the finish desired and the proper feed rate. A coarse tooth blade (2, 3 TPI) should be used for resawing wood and cutting thicker stock up to 8". A fine toothed blade (18 to 32 TPI) should be used for thinner metals and plastics under 1/4". For general cutting of 3/4" wood 4 TPI will provide a fast cut and 14 TPI will cut slow, but leave a smoother finish.

When Selecting TPI remember:

- More TPI give a smoother but slower cut
- Fewer TPI allow a faster cut with a slightly rougher finish
- At least three teeth must be in the workpiece—the chart to the right will help you decide.

TPI	Minimum Material Thickness
32	3/32"
24	1/8"
18	5/32"
14	1/4"
10	5/16"
8	3/8"
6	1/2"
4	3/4"
3	1"
2	1-1/2"

It is important to know the SFM for the various speed settings of your band saw, so that you can select the proper speed for cutting wood or other materials. Check the operator's manual of your band saw to determine the SFM or use the following procedure:

1. Determine the RPM: check the operator's manual or clock the revolutions per minute of the wheels with a tachometer or revolution counter.
2. Measure the diameter of the drive wheel in inches and multiply by .262 to obtain the wheel circumference. The RPM times circumference equals the surface speed of the blade.
RPM x diameter in inches x .262 = SFM.

Note: Spring Steel Wood Cutting Band Saw Blades should never be operated at surface speeds above 3000 SFM. Carbon Hard Edge Flexible Back Band Saw Blades may be run up to 8000 SFM.

Installing your Band Saw Blade

1. Unplug the saw, then loosen the tension on the upper wheel. With all the blade guides backed off, slip the new blade around the wheels and then tension it.
2. When you have tensioned the blade enough to keep it on the wheels, track it by turning the upper wheel with one hand while adjusting the tilt of the wheel's axis with the other hand. The blade should ride in the middle of the rim. **Never track the blade with the motor running and the cover open.**
3. Next, adjust the blade guides; first the thrust bearings: upper and lower, then the left hand side guides.
4. Use a square to make sure you are not pushing the blade out of line and place a piece of white paper between the blade guide and the blade to allow for clearance.

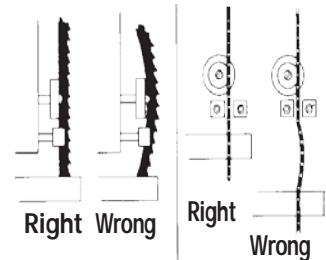

Diagnosing Problems

1. Premature and Excessive Tooth Wear

- Feed pressure too light, increase it.
- Lower band velocity.
- Improper tooth selection, use a finer pitch.
- Improper break-in with new band. Velocity and feeding should be reduced the first few cuts.
- Teeth are running the wrong direction. Be sure teeth are pointing in proper direction.
- Incorrect saw guide insert size for the band, allowing them to strike teeth



2. Blade Vibration

- Increase or decrease band velocity.
- Teeth too coarse for workpiece.
- Material not securely held.
- Increase tension of band.
- Increase feed pressure.

3. Gullets Loading

- Teeth too fine for workpiece - use a coarser pitch.
- Decrease band velocity.

4. Band Stalls in Work

- Feed pressure too great - decrease feed.
- Teeth too coarse, use finer tooth blade

5. Premature Blade Breakage

- Thickness of blade too heavy for diameter of wheels and speed of machine
- Increase or decrease velocity
- Check wheels for defects
- Teeth too coarse for workpiece - use a finer pitch
- Decrease blade tension - Decrease feeding force
- Brittle weld - increase annealing period, decreasing heat gradually
- Check for proper adjustment of band guides, saw guides, saw guide inserts, and back-up bearings.



6. Blade Making Belly-Shaped Cuts

- Increase tension.
- Adjust guides closer to workpiece.
- Teeth too fine - use a coarse pitch.
- Decrease feed force.
- Teeth dull.



7. Tooth Strippage

- Teeth too coarse for workpiece.
- Material not securely held.
- Too much feed pressure - reduce for good chip curl.
- Band velocity too low - increase speed.

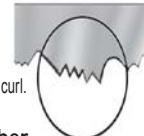

8. Band Develops a Negative Camber

- Band is riding on saw guide backup bearing too heavily. Adjust band for alignment on top and bottom wheels.
- Check band wheel alignment.



9. Blade Not Running True Against Saw Guide Backup Bearing

- If clicking noise against saw guide backup bearing, remove burr on band.
- Check band wheel alignment.
- Check saw guide backup bearing for wear, replace if necessary
- Weld not in proper alignment. Reweld blade straight and true.

10. Cutting Rate Too Slow

- Increase band velocity.
- Use a coarser pitch.
- Increase feed pressure.

11. Blade Leading In Cut

- Reduce feed pressure or rate.
- Check adjustments and wear of saw guides or rollers.
- Lack of band tension.
- Tooth set damage.



12. Premature Loss of Set

- Improper width selection - check chart for correct width for radius cutting.
- Reduce band velocity.

13. Band Develops Positive Camber

- Decrease force.
- Use a coarser pitch to increase tooth penetration.
- Adjust saw guides closer to work.



14. Band Develops Twist

- Wrong width for radius being cut - choose a narrower blade.
- Binding in cut - decrease feed pressure.
- Decrease band tension.
- Adjust saw guides further from workpiece.



15. Finished Cut Surface Too Rough

- Improper tooth selection - choose a finer pitch.
- Increase band velocity.
- Decrease feed rate.



16. Band Scoring (side wear or grooving)

- Check for wear on saw guide inserts.
- Too much pressure on saw guide inserts.
- Check alignment of saw guides - be sure they are square to front vise. Replace or clean guides.



17. Burring or Mushrooming of Blade Back Edge

- Increase tension and adjust guides.
- Check contact between blade and back edge rollers.
- Reduce feed pressure.
- Use coarser pitch blade.
- Use finishing stone.

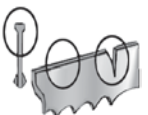

RIKON **POWER TOOLS**

5-Year Limited Warranty

RIKON Power Tools Inc. (“Seller”) warrants to only the original retail consumer/purchaser of our products that each product be free from defects in materials and workmanship for a period of five (5) years from the date the product was purchased at retail. This warranty may not be transferred.

This warranty does not apply to defects due directly or indirectly to misuse, abuse, negligence, accidents, repairs, alterations, lack of maintenance or normal wear and tear. Under no circumstances will Seller be liable for incidental or consequential damages resulting from defective products. All other warranties, expressed or implied, whether of merchantability, fitness for purpose, or otherwise are expressly disclaimed by Seller. This warranty does not cover products used for commercial, industrial or educational purposes.

This limited warranty does not apply to accessory items such as blades, drill bits, sanding discs or belts and other related items.

Seller shall in no event be liable for death, injuries to persons or property, or for incidental, contingent, special, or consequential damages arising from the use of our products.

To take advantage of this warranty proof of purchase documentation, which includes date of purchase and an explanation of the complaint, must be provided.

The Seller reserves the right to effect at any time, without prior notice, those alterations to parts, fittings, and accessory equipment which they may deem necessary for any reason whatsoever.

To take advantage of this warranty, please fill out the enclosed warranty card and send it to:
RIKON Warranty
16 Progress Rd.
Billerica, MA 01821

The card must be entirely completed in order for it to be valid. If you have any questions please contact us at 877-884-5167 or warranty@rikontools.com.



**For more information:
16 Progress Rd
Billerica, MA 01821**

**877-884-5167/978-528-5380
techsupport@rikontools.com
www.rikontools.com**

Free Manuals Download Website

<http://myh66.com>

<http://usermanuals.us>

<http://www.somanuals.com>

<http://www.4manuals.cc>

<http://www.manual-lib.com>

<http://www.404manual.com>

<http://www.luxmanual.com>

<http://aubethermostatmanual.com>

Golf course search by state

<http://golfingnear.com>

Email search by domain

<http://emailbydomain.com>

Auto manuals search

<http://auto.somanuals.com>

TV manuals search

<http://tv.somanuals.com>