



# **KUMA STOVES**

**HAYDEN, ID. USA**

**MODELS:**

**K-300 FIREPLACE INSERT**  
**K-400 FREE-STANDING WOOD STOVE**

**INSTALLATION AND OPERATING INSTRUCTIONS**

**\*SAVE THESE INSTRUCTIONS\***

**THIS MANUAL DESCRIBES THE INSTALLATION AND OPERATION OF THE KUMA MODEL K-300/K-400 WOOD STOVE/INSERT. UNDER SPECIFIC TEST CONDITIONS, THIS WOOD STOVE HAS BEEN SHOWN TO MEET THE U.S. ENVIRONMENTAL PROTECTION AGENCY'S EMISSION LIMITS FOR RESIDENTIAL WOOD STOVES.**

**PLEASE READ THIS ENTIRE MANUAL BEFORE YOU INSTALL AND USE YOUR NEW WOOD STOVE. FAILURE TO FOLLOW INSTRUCTIONS MAY RESULT IN PROPERTY DAMAGE, BODILY INJURY, OR EVEN DEATH.**

**CONTACT LOCAL BUILDING/FIRE OFFICIAL ABOUT CODES AND RESTRICTIONS IN YOUR AREA AND TO OBTAIN A PERMIT IF NECESSARY.**

## SECTION A- STOVE DESCRIPTION AND COMPLIANCE 1

This manual describes the installation and operation of the KUMA model K-300/K-400 catalytic equipped wood stove. This heater meets the U.S. Environmental Protection Agency's emission limits for wood stoves sold in the U.S. Under specific test conditions this wood stove has been shown to deliver heat at rates ranging from 10,100 to 52,100 BTU/hr.

## SECTION B— TAMPER WARNING

This wood stove contains a catalytic combustor, which needs periodic inspection and replacement for proper operation. It is against the law to operate this wood stove in a manner inconsistent with the operating instructions in this manual, or if the catalytic element is deactivated or removed.

## SECTION C- CATALYST INFORMATION

The combustor supplied with this wood stove is an Applied Ceramics FireCat Combustor. Consult the catalytic combustor warranty supplied with this wood heater. Warranty claims should be addressed to:

Applied Ceramics  
Customer Service Department  
5555 Pleasantdale Road  
Doraville GA 30340

Should the combustor become ineffective or require replacement, please take extreme care to package the combustor in foam rubber or other soft material so as not to damage it. Part number KRP-CATS (2.5"x 7.5"x 3"x 16 cell).

## SECTION D- FUEL SELECTION

This wood stove is designed to burn natural wood only. Higher efficiencies and lower emissions generally result when burning air seasoned hardwoods, as compared to softwoods or too green or freshly cut hardwoods.

***DO NOT BURN:*** treated wood, coal, garbage, cardboard, solvents, colored paper, trash, painted wood, rubber, plastic, sulfur, oil, metal foils, or flammable fluids.

Burning treated wood, garbage, solvents, colored paper, sulfur, oil, metal foils, or trash may result in release of toxic fumes and may poison or render ineffective the catalytic combustor. Burning coal, cardboard, or loose paper can produce soot or large flakes of char or fly ash that can plug the combustor, cause smoke spillage into the room, and rendering the combustor ineffective. Store fuel in a dry place. Do not place fuel within space heater installation clearances or within the space required for ash

## **SECTION E- ACHIEVING AND MAINTAINING CATALYST LIGHT-OFF**

Your KUMA stove is equipped with a by-pass plate that slides forward to allow the draft to escape up the chimney when the rod is pulled all the way forward. This “by-passes” the combustor for the purpose of (1) starting a fire, and (2) refueling. This section describes the position of the by-pass for 3 different burning situations.

1) *START-UP*: The by-pass rod would be pulled all the way out during start-up. It will remain open long enough to achieve a medium to high burn rate (about 15-20 minutes). It will also be necessary to “crack” the door to allow extra air during start-up. Check Operation Section ‘H’. Usually a normal fire start-up to produce a good coal bed will produce sufficient temperatures to begin catalytic combustion.

2) *NORMAL OPERATION*: After the start-up temperature is reached, the by-pass should be closed (pushed in). This begins the flow of smoke and gases through the combustor. The combustor will begin generating. The by-pass is to remain closed during normal operation.

3) *REFUELING*: The by-pass should be open (pulled out) during the refueling of the stove. When refueling or rekindling a cool fire or a fire that has burned down to the charcoal phase, operate the stove again at a medium to high burn rate (about 15-20 minutes) until a sufficient start-up temperature is reached.

## **SECTION F— CATALYST MONITORING**

It is important to periodically monitor the operation of the catalytic combustor to ensure that it is functioning properly, and to determine when it needs to be replaced. A non-functioning combustor will result in a loss of heating efficiency, and an increase in creosote and emissions. Following is a list of items that should be checked on a periodic basis:

- \*Combustors should be visually inspected at least three times during the heating season to determine if physical degradation has occurred. Actual removal of the combustor is not recommended unless more detailed inspection is warranted because of decreased performance. If any of these conditions exist, refer to Catalyst Troubleshooting Section ‘G’ in this owner’s manual.
- \*You can get an indication of whether the catalyst is working by comparing the amount of smoke leaving the chimney when the smoke is going through the combustor and catalyst light-off has been achieved, to the amount of smoke leaving the chimney when the smoke is not routed through the combustor (by-pass mode).

## SECTION F- CATALYST MONITORING (CONTINUED..)

- Step 1- Light stove in accordance with instructions in section 'E'.
- Step 2- With smoke routed in the by-pass mode, go outside and observe the emissions leaving the chimney.
- Step 3- Push in the by-pass mechanism and again observe the emissions leaving the chimney.

Significantly more smoke should be seen when the exhaust is not routed through the combustor (by-pass mode). Be careful not to confuse smoke with steam from wet wood.

## SECTION G- CATALYST TROUBLESHOOTING

<u>SYMPTOM</u>	<u>PROBLEM</u>	<u>REMEDY</u>
1. Stove doesn't seem to get rid of smoke.	*By-pass open *Old, cracked combustor *Poisoned combustor	*Close by-pass *replace combustor *replace combustor
2. Smoke spills out the door, or draft is slow and inhibited.	*Fly ash build-up	*Clean combustor cells by opening by-pass and Blowing air through combustors, thereby removing fly ash.

## SECTION H- OPERATION AND MAINTENANCE

**\*RECOMMENDATIONS FOR BUILDING AND MAINTAINING A FIRE:  
CAUTION: HOT WHILE IN OPERATION. KEEP CHILDREN, CLOTHING  
AND FURNITURE AWAY. CONTACT MAY CAUSE SKIN BURNS**

1. Pull by-pass control out to open.
2. Start with tinder and small kindling. When starting a fire, stack the wood in a 'criss-cross' arrangement so as to allow the fuel plenty of air. Place smaller chunks of wood on up to larger chunks until desired fire is reached.
3. Open air vent controls. Crack door open 1/2" to help establish start-up fire. Close after start up is achieved. The door will need to remain cracked open approximately 25-30 minutes (close door 10 minutes after you close by-pass).
4. Leave by-pass and air controls fully open until a medium to high burn rate is achieved (about 15-20 minutes). After start-up, push by-pass control in. Adjust the air controls at bottom to achieve the desired heat output. See

5. The slide type air controls can be slid open to allow more air to the fire, thus increasing the fire size, rate of burn, and heat produced. Likewise, sliding the air controls closed or decreasing the air to the fire decreases the fire size, rate of burn, and heat produced.
6. Never leave your stove unattended with the door open. When the stove door is open it will be necessary to open the by-pass to prevent smoke spillage.
7. *CAUTION:* When building the first couple of fires be careful to build the fire small and increase heat slowly over a 4-5 hour period. The paint on the stove “cures” with heat and this process needs to be done slowly. As the paint “cures” it gives off a smell of paint and sometimes a visible “smoky” haze in the room. Make sure the area is well ventilated during the curing operation. The smell will disappear after a few hours of operation.

## **SECTION I- CATALYST REPLACEMENT**

### *Gasket Replacement:*

Periodically, gasket on your wood stove will need to be replaced. The following is a list of parts and sizes of gasket used:

- 1) Door Gasket: 5/8” diameter (5 ft.)
- 2) Glass Gasket: Window channel with adhesive (5 ft.)
- 3) Catalytic Gasket: 1/16”x 3” (8 ft.)
- 4) By-pass Gasket: 1/8”x 1 1/2” (3 feet required)

*\*SEE FIGURE 1 FOR LOCATIONS OF GASKET\**

### **CATALYTIC REPLACEMENT STEPS:**

- 1) Pull insert or stovepipe out.
- 2) Remove by-pass rod by unscrewing fastening nuts. (A)
- 3) Lubricate and remove the 4 main holding bolts. (B) You may need to support the baffle before doing this, as it is heavy.
- 4) Remove entire catalytic baffle system from stove.
- 5) Lift off catalytic hold-down clamp noting location of all gasket. (C)
- 6) Slide catalytic units up and out. (D)
- 7) Rewrap new catalytic units with new 1/8”x 3” gasket, or replace with pre-wrapped catalytic assembly in stainless steel enclosure.
- 8) Re-install catalytic units in place being careful to have a ‘snug’ fit. It may be necessary to add more gasket to achieve a snug fit.
- 9) Replace catalytic hold-down clamp and re-gasket top area with gasket (1/8”x 3”) as shown in Figure 1.
- 10) Re-install entire catalytic baffle system with 4 bolts and hook up by-pass rod with nuts.
- 11) Double check bolts and fasteners for tightness.

*Note: If the steel baffle (catalytic enclosure) system is warped or degraded, an entire baffle system with catalytics and gasketing already installed may be ordered and replaced as a unit. Contact your dealer.*

## SECTION J- STOVE MAINTENANCE WARNINGS

**DO NOT OVERFIRE THIS HEATER:**  
**EXCESSIVE TEMPERATURES CAN CAUSE THE**  
**STEEL PLATE TO WARP OR CRACK.**

*\*CAUTION:*

**Never use gasoline, gasoline-type lantern fuel, kerosene, charcoal lighter fluid or similar liquids to start or ‘freshen-up’ a fire in this heater. Keep all such liquids well away from the wood stove while it is in use.**

*\*CREOSOTE: Formation and need for removal*

When wood is burned slowly, it produces tar and other organic vapors, which combined with expelled moisture forms creosote. The creosote vapors condense in the relatively cool chimney flue of a slow burning fire. As a result, creosote residue accumulates on the flue lining. When ignited, this creosote makes an extremely hot fire. The chimney connector and chimney should be inspected at least once every two months during the heating season to determine if a creosote build-up has occurred. If creosote has accumulated, it should be removed to reduce the risk of a chimney fire.

*\*DISPOSAL OF ASHES:*

Ashes should be placed in a metal container with a tight fitting lid. The closed container of ashes should be placed on a non-combustible floor or on the ground, well away from all combustible materials, pending final disposal. If the ashes are disposed of by burial in soil or otherwise locally dispersed, they should be retained in the closed container until all cinders have thoroughly cooled.

*\*USE OF GRATE IS NOT NECESSARY FOR PROPER OPERATION OF THIS STOVE.*

## SECTION K- PROPER DRAFT INFORMATION

*ACHIEVING PROPER DRAFT:*

Draft is the force which moves air from the appliance through the chimney. The amount of draft in your chimney depends on the length of the chimney, local geography, nearby obstructions, and other factors. Too much draft may cause excessive temperatures in the appliance and may damage the catalytic combustor. Inadequate draft may cause backpuffing into the room and plugging of the chimney or the catalytic. Inadequate draft will cause the appliance to leak smoke into the room through the

## SECTION K- PROPER DRAFT INFORMATION

(CONTINUED..)

appliance and chimney connector joints. An uncontrollable burn or a glowing red stove part or chimney connector indicates excessive draft. A poor draft can cause poor stove performance and can be remedied with a positive connect or chimney liner. Consult your dealer for help. KUMA stoves are approved for use with or without liner connect in properly constructed, clay-lined masonry chimneys.

## SECTION L- K-400 FREE-STANDING WOOD STOVE INSTALLATION INSTRUCTIONS

If this wood stove is not properly installed, a house fire may result. To reduce the risk of fire, follow the installation instructions. **WARNING:** Do not compromise clearances, codes, or materials used. Contact local building or fire officials about restrictions and installation inspection requirements in your area. We also recommend that your Kuma model HT wood stove be installed by a properly trained and licensed installer, preferably an NFI (National Fireplace Institute) expert.

### \*PARTS REQUIRED:

- 1) Model K-400 wood stove– 8” flue
- 2) Floor protector
- 3) Chimney connector (stovepipe)
- 4) Chimney (*Refer to figure 5*)
  - a. Chimney sections
  - b. Fire stop
  - c. Support box
  - d. Storm collar
  - e. Roof flashing
  - f. Chimney spark arrestor cap

***USE ONLY 8” DIAMETER CHIMNEYS THAT HAVE BEEN TESTED TO ALL APPLICABLE U.L. 103-HT STANDARDS.***

**\*Floor Protector-** The floor protector must be non-combustible and must be a minimum of 46” wide and 48” deep (U.S.) and 46” wide and 50” deep (CAN.). Situate heater on floor protector according to the following: *Dimensions:* At least 18” of floor protector in front of the stove and at least 8” beyond each side of the door opening. Floor protector shall be large enough to cover under the flue pipe and 2” beyond each side of the flue connector (*see figure 4*).

**\*Chimney Connector-** Use chimney connectors (flue pipe) that has been approved for use with this appliance. The connector shall be 8” in diameter, and made of steel, 24 gauge thickness minimum. The chimney connector shall be slipped inside the flue of the stove and should be screwed to the flue for maximum safety. Each chimney connector section should be fastened securely together with screws. Approved double-wall connector may be used for reduced clearance applications (see figs. 2 and 3).

(continued...)

## SECTION L- INSTALLATION INSTRUCTIONS (CONTINUED..)

A stove top connector section may be required with reduced clearances installations (double-wall connector). **WARNING: Never pass a chimney connector through an attic or roof space, closet or similar concealed space, or a floor or ceiling.** Where passage through a wall or partition of combustible construction is desired, the installation shall conform to CAN/CSA-B365. DO NOT CONNECT TO ANY AIR DISTRIBUTION OR DUCT SYSTEM.

*\*Chimney-* This room heater must be connected to either an 8" chimney complying with the requirements for Type HT chimneys in the standard for Chimneys, Factory-Built, Residential Type and Building Heating Appliance, UL HT 103, or a code approved masonry chimney with a flue liner. (See figure 5 for list of parts).

*\*CLEARANCES-* Refer to Section 'O' figures 2 and 3 for minimum installation clearances to combustibles. NOTE: Clearances may only be reduced by means approved by the regulatory authority.

### INSTALLATION INSTRUCTIONS:

- 1) Set the unit on the floor protector.
- 2) Make sure the clearance from the unit to combustibles is according to the minimum clearances in figures 2 and 3. Also make sure of the minimum clearances from the chimney connector to combustibles.
- 3) Check the minimum clearances on the floor protector as per figure 4.
- 4) Connect the unit to the chimney with the chimney connector (stovepipe) using a slip connector usually supplied in a basic stovepipe kit.
- 5) Fasten the stove pipe sections together securely with screws, and screw the stovepipe to chimney connection at ceiling or wall.
- 6) Double check all clearances and connections before operation.

***\*DO NOT CONNECT THIS APPLIANCE TO A CHIMNEY  
SERVING ANOTHER APPLIANCE\****

***\*THIS STOVE IS NOT APPROVED FOR  
INSTALLATION INTO MOBILE HOMES\****

### List of Replacement Parts (K-300 or K-400)

KRP-CATS- Catalytics and Gasket  
 KRP-GLASS1- Glass  
 KRP-GSKT58- Door Gasket Kit (5')

KRP-GSKT34- Window Gasket Kit (5')



## SECTION M- K-300 FIREPLACE INSERT INSTALLATION INSTRUCTIONS

With the addition of a fireplace insert surround kit (part # W-KWSK) your K-300/K-400 unit may be installed and used in masonry fireplaces only (lined, masonry chimneys constructed in accordance with NFPA 211 guidelines). **NOT APPROVED FOR USE IN FACTORY-BUILT OR ZERO CLEARANCE FIREPLACES.** If your masonry chimney is damaged, deteriorated, or unlined, a stainless steel liner (8" diameter) with thermal wrap will need to be installed and connected directly to the K-300 flue opening. If you are unsure of the condition of your chimney, have it inspected by your dealer or a chimney professional. Use and install liner kits that are approved to UL 1777 only. If your masonry fireplace/chimney is in good shape, your K-300 is approved for installation and use with or without a direct-connect liner system. There is no replacement for a proper draft to ensure optimum performance from your K-300, so a stainless steel liner could be necessary for a proper draft. As a general guideline, if the flue area (interior dimensions) of your chimney is 100 sq. inches or less, your insert should draft fine. Due consideration of all conditions that could affect draft such as chimney height, geographical conditions, location, climate, etc. should be noted. Contact your dealer with any questions.

### PRELIMINARY CHECKS:

\*A preliminary check of the chimney should be made. Check for any obstructions, cracks, or deterioration. If there is any evidence of deterioration of any kind, repairs should be made before installation. Also check for excess creosote build up and clean if necessary. If a stainless steel liner system is being used, install according to the liner manufacturer's instructions.

\*Make sure the damper in your fireplace is in the full open position or removed before installing the insert. Also make sure there is no danger of the damper handle closing accidentally or that installation of the insert would bump the handle closed.

\*Double check the drop in the fireplace from the hearth measured down to the bottom of the firepit area. Check to make sure you have the proper height roller or pipe (see fig. 6) needed to roll the insert into place. Option: 2- 3/8" N.C. bolts of appropriate lengths may be screwed into the threaded holes at the insert bottom rear corners for the "drop" in the firepit area if necessary. A piece of sheet metal laid in the firepit bottom will be helpful so the bolt heads can slide easily as the insert is being pushed in.

\*Determine the position of the faceplate.

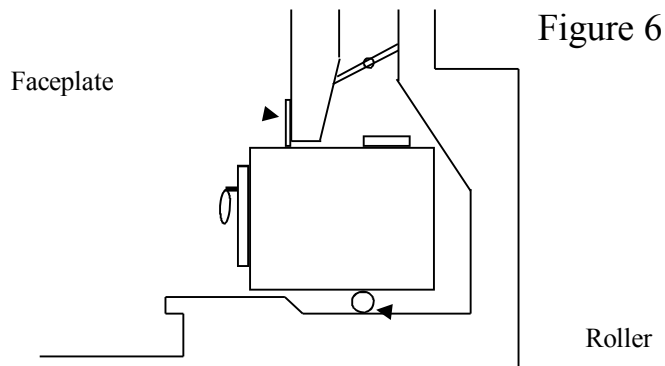

## SECTION M— K-300 INSTALLATION INSTRUCTIONS (CONTINUED...)

### Installation Procedure:

1. Protect the hearth with a carpet or some soft material so the insert will not damage the hearth.
2. Set the insert on the hearth by dolly or some other means.
3. Place the roller about 6 inches back from the hearth in the firepit.
4. Center the insert and roll into the fireplace all the way to the back wall.
5. Position the faceplate pieces (left, right, and top) against the fireplace wall and check for fit. Make sure there is enough faceplate covering the fireplace brick to cover the opening. If the faceplate is too narrow, optional widths are available. Contact your dealer.
6. Mark the faceplate position on your insert sides and top.

### *Attaching the faceplate:*

1. After marking for the faceplate, pull the insert out enough to attach the fasteners.
2. Reposition the faceplate back to the insert in the marked locations.
3. Attach the faceplate pieces with supplied self-drilling, self-tapping fasteners.
4. Place fiberglass insulation around the faceplate back to seal it against the fireplace brick.  
Note: Construction grade fiberglass building insulation may be used (make sure there is no paper barrier attached.)
5. Assemble 3 piece gold trim kit and slide down over surround from the top (faceplate fits into 1/8" groove on gold trim interior).
6. Roll or slide insert back until faceplate contacts fireplace face. Check and make sure insulation is sealing up all gaps behind faceplate.
7. Check final non-combustible clearance at insert front. You must have 18" of non-combustible hearth in front of your K-300. If not, a hearth pad extension of 3/8" minimum thickness must be installed (brick, tile, metal, stone, etc.).
8. Your K-300 insert is now ready for operation. Be sure and check the operation and maintenance section of this manual before operation. Contact your dealer if you have any questions.

## **SECTION N- WARRANTY**

### **LIMITED LIFETIME WARRANTY**

Your KUMA wood burning system is warranted for lifetime to the original purchaser against defects in materials or workmanship on the firebox and all welded steel components. Warranty does not cover gold, brass, or nickel items, glass or normal maintenance items such as paint, gasket, or the catalytic baffle system. This warranty does not apply in cases of abuse, mishandling, unauthorized repair, or alterations, failures, or operating difficulties due to misuse, accident, improper installation, improper maintenance or improper service. Kuma Stoves reserves the right under this warranty to repair, replace, or authorize repair of a defective stove or part at their discretion. Any warranty concern should be directed to your dealer, who will contact us. Catalytic combustors are covered under a pro-rated warranty by the catalytic manufacturer.

***\*SAVE THESE INSTRUCTIONS!\****

Figure 1

SECTION O-  
FIGURES 1-5

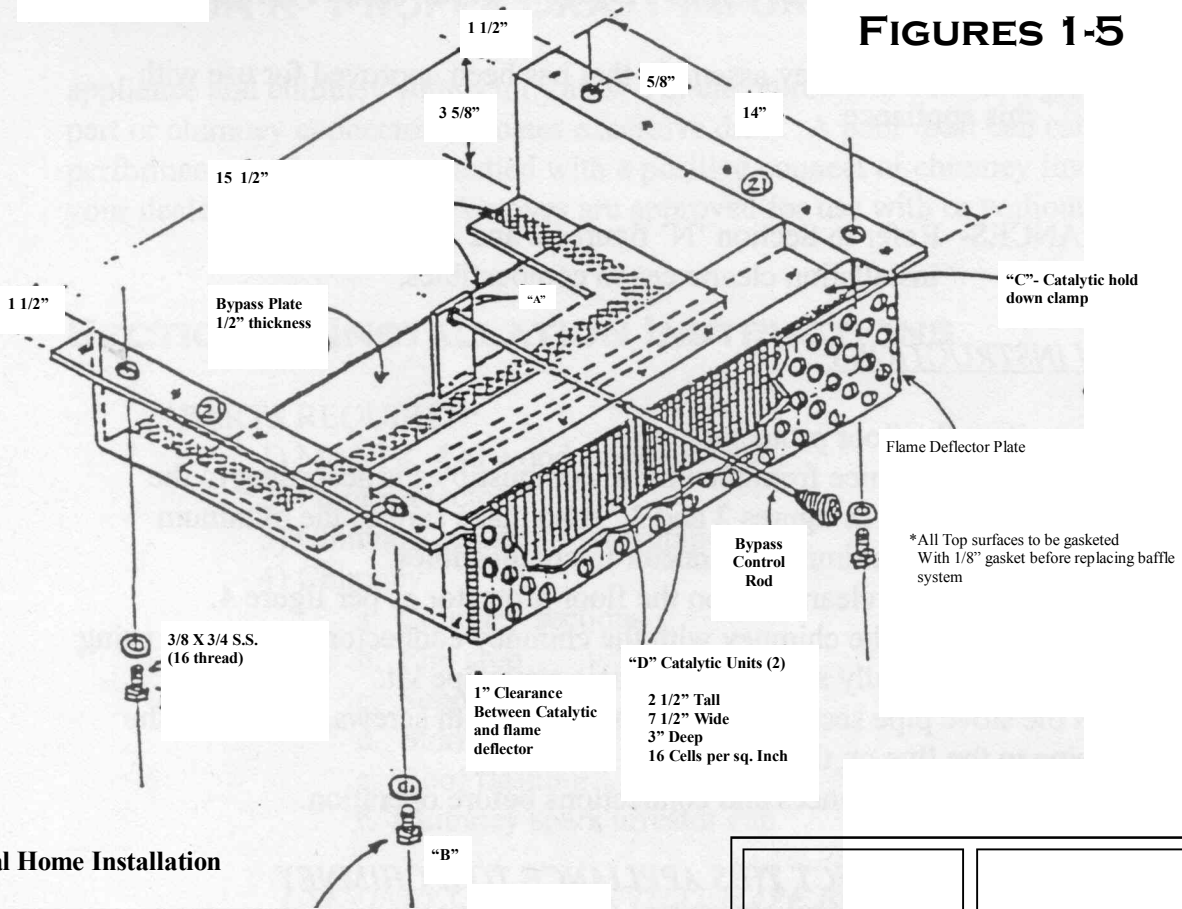

Typical Home Installation

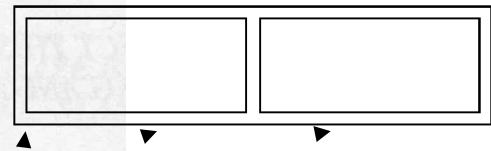

Re-gasket each catalytic unit once with 1/8" X 2" gasket  
Wrap each pre-wrapped unit with 1/8" X 2" gasket

Figure 5

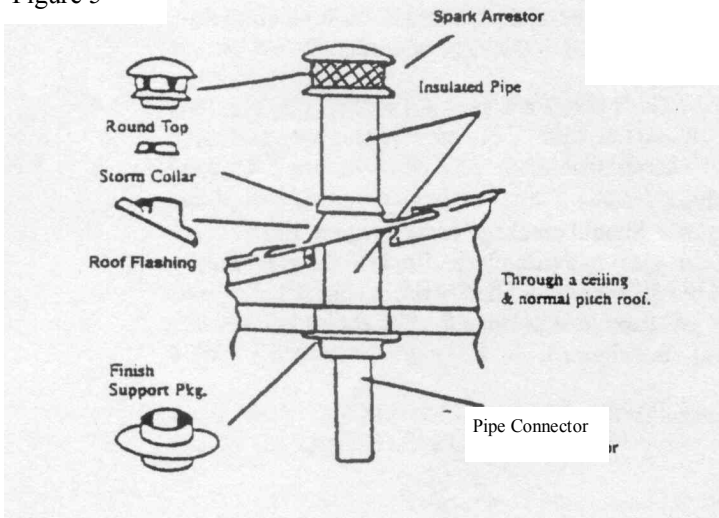

**All KUMA stoves must be installed and operated in accordance with all local, state, and Federal laws, codes, and ordinances.**

NOTE: All reduced clearance installations must use U.L. approved double wall stove pipe.

Figure 2

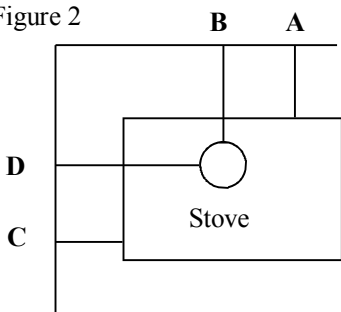

U.S. (in inches)	
Standard Clearance	Reduced Clearance
A = 14	A = 7
B = 18	B = 11
C = 22	C = 15
D = 36	D = 27
E = 24	E = 19
F = 22	F = 15
G = 36	G = 27

Canada (en mm)	
A = 406	A = 229
B = 508	B = 330
C = 635	C = 406
D = 914	D = 686
E = 660	E = 533
F = 432	F = 305
G = 914	G = 686

Figure 3

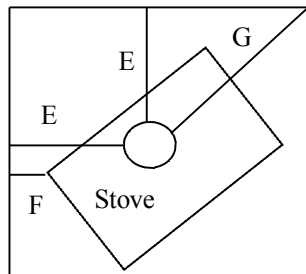
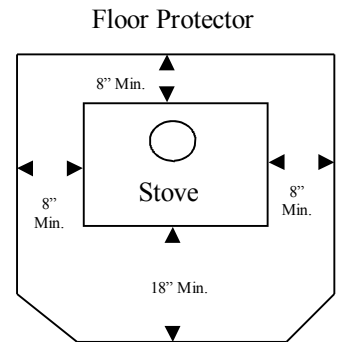

Figure 4



## Free Manuals Download Website

<http://myh66.com>

<http://usermanuals.us>

<http://www.somanuals.com>

<http://www.4manuals.cc>

<http://www.manual-lib.com>

<http://www.404manual.com>

<http://www.luxmanual.com>

<http://aubethermostatmanual.com>

Golf course search by state

<http://golfingnear.com>

Email search by domain

<http://emailbydomain.com>

Auto manuals search

<http://auto.somanuals.com>

TV manuals search

<http://tv.somanuals.com>